

Operator's Manual

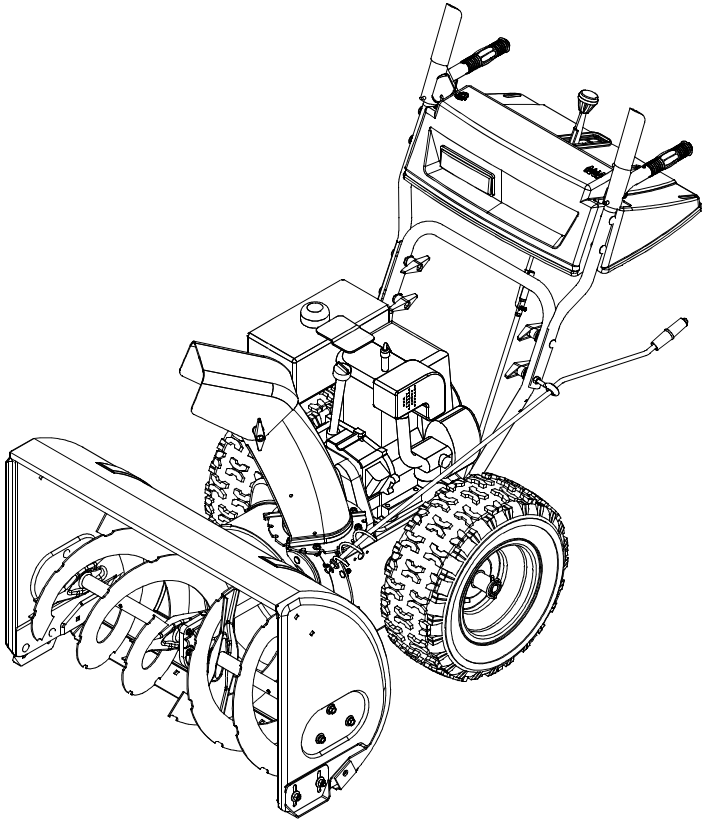

**Model
E663G**

IMPORTANT: Read safety rules and instructions carefully before operating equipment.

Warning: This unit is equipped with an internal combustion engine and should not be used on or near any unimproved forest-covered, brush-covered or grass-covered land unless the engine's exhaust system is equipped with a spark arrester meeting applicable local or state laws (if any). If a spark arrester is used, it should be maintained in effective working order by the operator. In the State of California the above is required by law (Section 4442 of the California Public Resources Code). Other states may have similar laws. Federal laws apply on federal lands. A spark arrester for the muffler is available through your nearest engine authorized service dealer or contact the service department, P.O. Box 368022 Cleveland, Ohio 44136-9722.

MTD PRODUCTS INC. P.O. BOX 368022 CLEVELAND, OHIO 44136-9722

PRINTED IN U.S.A.

FORM NO. 770-10049A
(6/99)

TABLE OF CONTENTS

Content	Page
Important Safe Operation Practices.....	3
Loose Parts.....	5
Assembling Your Snow Thrower.....	5
Know Your Snow Thrower	7
Operating Your Snow Thrower.....	8
Making Adjustments	10
Maintaining Your Snow Thrower.....	12
Service.....	13
Off-season Storage.....	15
Troubleshooting.....	16
Parts List.....	17

FINDING MODEL NUMBER

This Operator's Manual is an important part of your new Snow Thrower. It will help you assemble, prepare and maintain the unit for best performance. Please read and understand what it says.



Before you start assembling your new equipment, please locate the model plate on the equipment and copy the information from it in the space provided below. The information on the model plate is very important if you need help from our Customer Support Department or an authorized dealer.

- You can locate the model number by looking at the lower frame cover in the rear of your snow thrower. A sample model plate is explained below. For future reference, please copy the model number and the serial number of the equipment in the space below.

_____	_____
(Model Number)	(Serial Number)



MTD PRODUCTS INC
CLEVELAND, OHIO 44136

Copy the model number here: _____

Copy the serial number here: _____

CALLING CUSTOMER SUPPORT

If you have difficulty assembling this product or have any questions regarding the controls, operation or maintenance of this unit, please call the Customer Support Department.



Call **1- (330) 220-4MTD (4683)** or **1- (800)-800-7310** to reach a Customer Support representative. Please have your unit's model number and serial number ready when you call. See previous section to locate this information. You will be asked to enter the serial number in order to process your call.

SECTION 1: IMPORTANT SAFE OPERATION PRACTICES



This Warning symbol points out important safety instructions which, if not followed, could endanger the personal safety and/or property of yourself and others. Read and follow all instructions in this manual before attempting to operate your snow thrower. Failure to comply with these instructions may result in personal injury. When you see this symbol, heed its warning.

DANGER: Your snow thrower was built to be operated according to the rules for safe operation in this manual. As with any type of power equipment, carelessness or error on the part of the operator can result in serious injury. Failure to observe the following safety instructions could result in serious injury or death.

TRAINING

- Read this operators manual carefully in its entirety before attempting to assemble or operate this machine. Be completely familiar with the controls and the proper use of this machine before operating it. Keep this manual in a safe place for future and regular reference and for ordering replacement parts.
- Never allow children under 14 years old to operate a snow thrower. Children 14 years old and over should only operate snow thrower under close parental supervision. Only persons well acquainted with these rules of safe operation should be allowed to use your snow thrower.
- No one should operate this unit while intoxicated or while taking medication that impairs the senses or reactions.
- Keep the area of operation clear of all persons, especially small children and pets.
- Exercise caution to avoid slipping or falling, especially when operating in reverse.

PREPARATION

- Thoroughly inspect the area where the equipment is to be used and remove all door mats, sleds, boards, wires and other foreign objects.
- Disengage all clutches and shift into neutral before starting engine.
- Do not operate equipment without wearing adequate winter outer garments. Do not wear jewelry, long scarfs or other loose clothing which could become entangled in moving parts. Wear footwear which will improve footing on slippery surfaces.
- Before working with gasoline, extinguish all cigarettes and other sources of ignition. Check the fuel before starting the engine. Gasoline is an extremely flammable fuel. Do not fill the gasoline tank indoors, while the engine is running, or until engine has been allowed to cool at least two minutes. Replace gasoline cap securely and wipe off any spilled gasoline before starting the engine as it may cause a fire or explosion.

- Use a grounded three wire plug-in for all units with electric drive motors or electric starting motors.
- Adjust collector housing height to clear gravel or crushed rock surface.
- Never attempt to make any adjustments while engine is running (except where specifically recommended by manufacturer).
- Let engine and machine adjust to outdoor temperature before starting to clear snow.
- Always wear safety glasses or eye shields during operation or while performing an adjustment or repair, to protect eyes from foreign objects that may be thrown from the machine in any direction.

OPERATION

- Do not put hands or feet near or under rotating parts. Keep clear of discharge opening and auger at all times.
- Exercise extreme caution when operating on or crossing gravel drives, walks, or roads. Stay alert for hidden hazards or traffic. Do not carry passengers.
- After striking a foreign object, stop the engine, remove wire from spark plug, and thoroughly inspect the snow thrower for any damage. Repair the damage before restarting and operating the snow thrower.
- If the snow thrower should start to vibrate abnormally, stop the engine and check immediately for the cause. Vibration is generally a warning of trouble.
- Stop engine whenever you leave the operating position, before unclogging the collector/impeller housing or discharge guide, and making any repairs, adjustments, or inspections. Never place your hand in the discharge or collector openings. Use a stick or wooden broom handle to unclog the discharge opening.
- Take all possible precautions when leaving the unit unattended. Disengage the collector/impeller, shift into neutral, stop the engine, and remove the key.

- When cleaning, repairing, or inspecting, make certain the auger, impeller and all moving parts have stopped. Disconnect spark plug wire and keep away from plug to prevent accidental starting.
- Do not run engine indoors, except when starting engine and transporting snow thrower in or out of building. Open doors. Exhaust fumes are dangerous.
- Do not clear snow across the face of slopes. Exercise extreme caution when changing direction on slopes. Do not attempt to clear steep slopes.
- Never operate snow thrower without guards, plates, or other safety protection devices in place.
- Never operate snow thrower near glass enclosure, automobiles, window wells, drop off, etc., without proper adjustments of snow thrower discharge angle. Keep children and pets away.
- Do not overload machine capacity by attempting to clear snow at too fast a rate.
- Never operate the machine at high transport speeds on slippery surfaces. Look behind and use care when backing.
- Never direct discharge at bystanders or allow anyone in front of unit.
- Disengage power to collector/impeller when transporting or not in use.
- Use only attachments and accessories approved by the manufacturer of snow thrower (such as tire chains, cabs, etc.).
- Never operate the snow thrower without good visibility or light. Always be sure of your footing and keep a firm hold on the handles. Walk, never run.
- Muffler and engine become hot and can cause a burn. Do not touch.

MAINTENANCE AND STORAGE

- Check shear bolts, engine mounting bolts, etc., at frequent intervals for proper tightness to be sure equipment is in safe working condition.
- Never store the machine with fuel in the fuel tank inside a building where ignition sources are present, such as hot water and space heaters, clothes dryers, and the like. Allow engine to cool before storing in any enclosure.
- Always refer to operators manual instructions for important details if snow thrower is to be stored for an extended period.
- Run machine a few minutes after throwing snow to prevent freeze up of collector/impeller. Check clutch controls periodically to verify they engage and disengage properly and readjust if necessary. Refer to operators manual for adjustment instructions.

Your Responsibility



Restrict the use of this power machine to persons who read, understand and follow the warnings and instructions in this manual and on the machine. **Some of the safety labels on the equipment are reproduced below.** Take a moment to study these labels before operating the unit. Always maintain safety while operating or servicing the equipment.

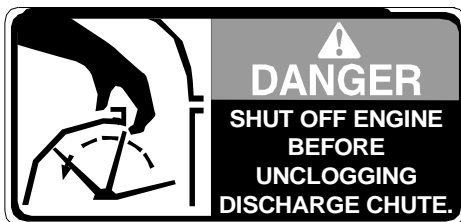

SECTION 2: LOOSE PARTS

The snow thrower is shipped with following loose parts in the carton. Please remove all loose parts from the carton before discarding it. See Figure 1 to identify the parts noting that these parts may be referred to again in the following sections of this manual. Part numbers are shown in parentheses.

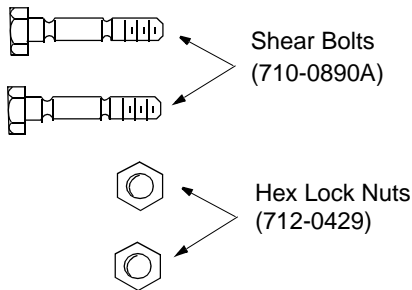

Figure 1

AUGER SHEAR BOLTS

The augers are secured to the auger shaft with two shear bolts and hex lock nuts. If you hit a foreign object or ice jam, the snow thrower is designed so that the bolts may shear. Two replacement shear bolts and nuts are provided for your convenience. Store in a safe place until needed.

IMPORTANT: NEVER replace the auger shear bolts with standard hex bolts. Any damage to the auger gearbox or other components as a result of doing so will NOT be covered by your snow thrower's warranty.

SECTION 3: ASSEMBLING YOUR SNOW THROWER

NOTE: Any reference in this manual to the left or right side of the snow thrower is observed from the operator's position.

IMPORTANT: Make any final adjustments as instructed later on in this section BEFORE operating your snow thrower. Failure to follow the instructions may cause damage to the snow thrower.

- Remove screws from the top sides and ends of the shipping crate.
- Set panel aside to avoid tire punctures or personal injury.
- Remove and discard plastic bag that covers unit.
- Roll unit out of crate.
- Remove the **lower** two plastic wing knobs, cupped washers and carriage bolt (eyebolt on the left side) from the lower handle. See Figure 2.

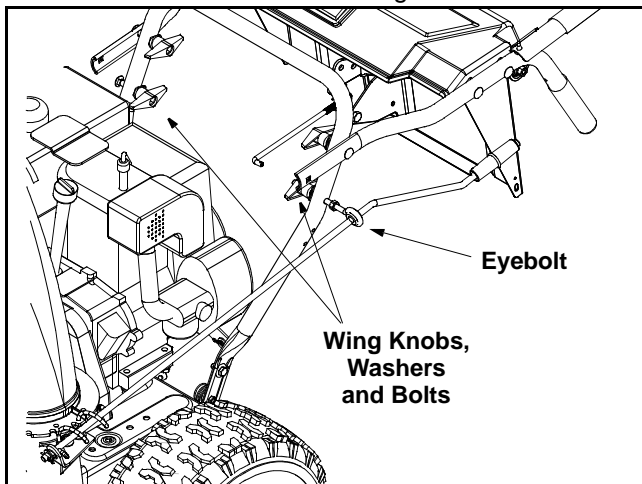

Figure 2

- Raise the upper handle assembly until it locks over the lower handle. See Figure 2 and Figure 3.
- Look at the lower rear of snow thrower frame to be sure both cables are aligned with cable roller guides.
- Secure the upper handle and lower handle with the two plastic wing knobs, cupped washers and carriage bolt (eyebolt on the left side) previously removed. See Figure 3.

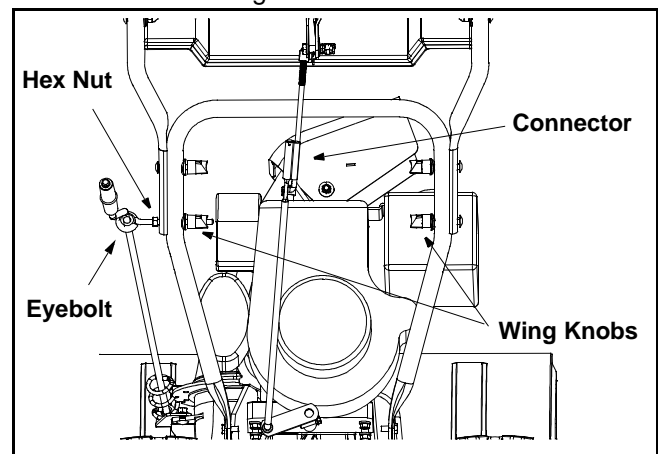

Figure 3

- Adjust the eyebolt on the chute directional control so the rod does not come into contact with the engine by moving the hex nut against the handle (if necessary). Retighten the wing nut to secure the directional control in this position.
- Slide the connector down over the end of the lower shift rod. See Figure 3. Tap the connector until it **locks** on the lower shift rod.

NOTE: If the connector is not properly assembled, the shift rod will pivot and you will not be able to change speeds or change directions.

- Unwrap the headlight wire which is attached to the headlight, beneath the handle panel. Wind the headlight wire around the right handle until excess slack is removed.
- Plug the wire from the headlight into the wire lead coming from the right side of the engine, beneath the fuel tank.

Final Adjustments

Auger Control Adjustment

Check the adjustment of the auger control as follows:

- Push forward on the auger control (Refer to Figure 6) until the small rubber bumper contacts the upper handle. There should be slack in the cable.
- Release the auger control. The cable should be straight. Make certain you can depress the auger control against the left handle completely.

If adjustment is necessary, proceed as follows:

- Loosen the jam nut and thread the cable in (for less slack) or out (for more slack) as necessary. See Figure 4.

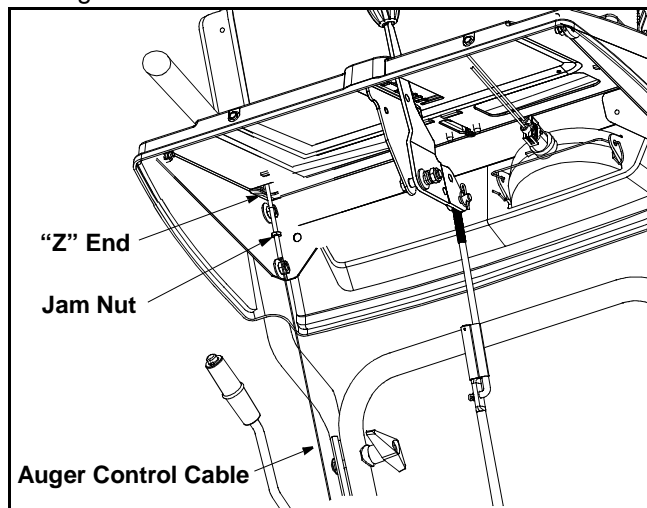

Figure 4

- Recheck the adjustment before retightening the jam nut against the cable.

Skid Shoe Adjustment

The space between the shave plate and the ground can be adjusted by repositioning the skid shoes found on either side of the snow thrower's auger housing. For close snow removal, place skid shoes in the low position.

Use middle or high position when area to be cleared is uneven. See Figure 5.

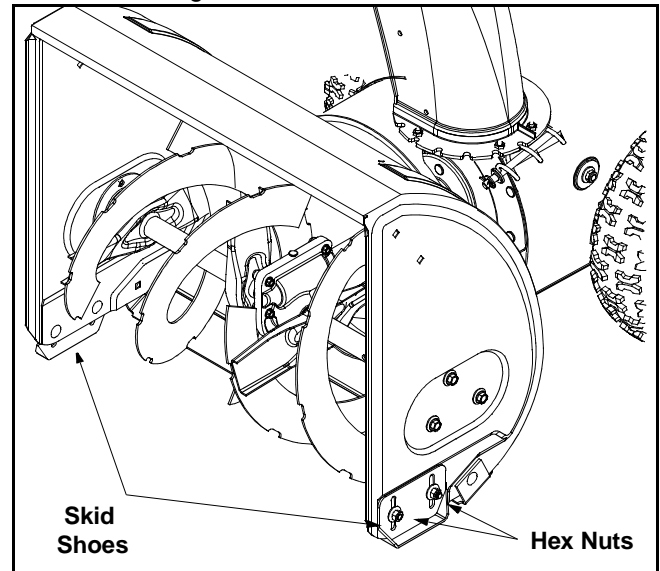

Figure 5

IMPORTANT: It is NOT recommended that this snow thrower be operated on a gravel surface, as loose stones can be easily picked up and thrown by the machine. If you must operate on a gravel surface, ALWAYS adjust the skid shoes into the HIGH position to allow the shave plate maximum clearance.

Adjust skid shoes as follows:

- Loosen, but do NOT remove, the two hex nuts which fasten the skid shoe to the auger housing.
- Raise or lower the skid shoe to desired position.

NOTE: Make certain the entire base of both skid shoes are against the ground to avoid uneven wear on the skid shoes.

- Retighten the hex nuts loosened earlier.
- Repeat this adjustment on the skid shoe found on the opposite side of the snow thrower.

Tire Pressure Adjustment

The tires are over-inflated for shipping purposes. Adjust the tire pressure to between 15 psi and 20 psi.

NOTE: If the tire pressure is not equal in both tires, the unit may pull to one side or the other.

Traction Control and Shift Lever Adjustment

To check the adjustment of the traction control and shift lever, proceed as follows:

- Move the shift lever into sixth (6) position.
 - a. With the traction control (refer to Figure 6 in Section 4 of this manual) released, gently push the snow thrower forward, then pull it back. Disregarding the overall weight of the snow thrower, the machine should otherwise move freely.

- b. Engage the traction control, and attempt to move them machine both forward and rearward. You should experience resistance as the wheels should not be turning.
 - Move the shift lever into the fast reverse (R2) position and repeat the previous steps (a & b).
- If you experienced resistance either when repositioning the shift lever from 6 to R2 or when attempting to move the machine forward or rearward with the traction control released, your snow thrower's traction control is in need of adjustment and you should NOT operate the machine before completing the adjustment as follows:

- Loosen the jam nut on the traction control cable and UNTHREAD the cable one full turn.
- Recheck the adjustment.

- Retighten the jam nut to secure the cable when correct adjustment is reached.

If the machine can be moved freely both forward and rearward when the traction control fully depressed, proceed as follows:

- Loosen the jam nut on the traction drive cable and THREAD the cable in one full turn.
- Recheck the adjustment and repeat adjustment as necessary.
- Retighten the jam nut to secure the cable when correct adjustment is reached.

NOTE: *If you are uncertain that you have reached the correct adjustment, refer to Traction Control Adjustment in Section 6 of this manual.*

SECTION 4: KNOW YOUR SNOW THROWER

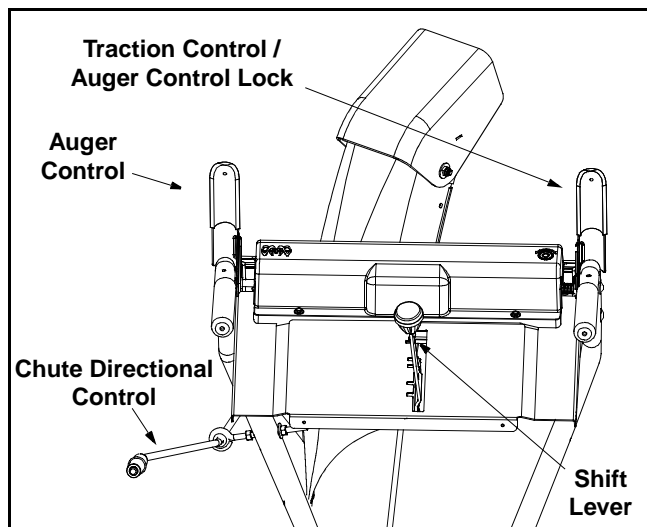

Figure 6

Traction Control / Auger Control Lock

The traction control is located on the right handle. Squeeze the traction control to engage the wheel drive. Release to stop. This same lever also locks the auger control so you can turn the chute directional control without interrupting the snow throwing process. If the auger control is engaged along with the traction control, the operator can release the auger control (on the left handle) and the augers will remain engaged. Release the traction control to stop both the augers and wheel drive (auger control must also be released).

IMPORTANT: Always release tractional control before changing speeds.

Headlight

The headlight is on whenever the engine is running.

Shift Lever

The shift lever is located in the center of the handle panel and is used to determine both ground speed and direction of travel. It can be moved into any of eight positions.

Forward

Your snow thrower has six forward (F) speeds. Position number one (1) is the slowest. Position number six (6) is the fastest.

Reverse

Your snow thrower has two reverse (R) speeds. R1 is the slower, while R2 is the faster of the two.

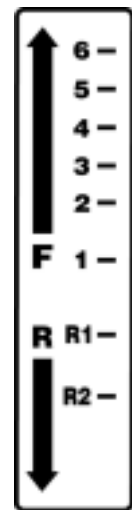

IMPORTANT: Always release tractional control before changing speeds.

Auger Control

The auger drive clutch is located on the left handle. Squeeze the clutch grip to engage the augers. Release to stop the snow throwing action. (Traction control must also be released.)

Chute Directional Control

The chute directional control is located on left side of the snow thrower.

To change the direction in which snow is thrown, turn chute directional control as follows:

- Crank clockwise to discharge to the left.
- Crank counterclockwise to discharge to the right.

Fuel Shut-off Valve

The fuel shut-off valve, located under fuel tank, controls fuel flow from the tank. Always make certain it is in the Open (vertical) position before attempting to start the engine.

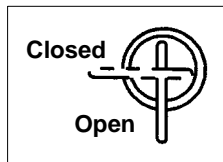

Throttle Control

The throttle control is located on the engine. It regulates the speed of the engine.

Safety Ignition Key

The safety ignition key must be fully inserted in the switch before the unit will start. Remove the ignition key when snow thrower is not in use.

IMPORTANT: Do NOT attempt to turn the key.

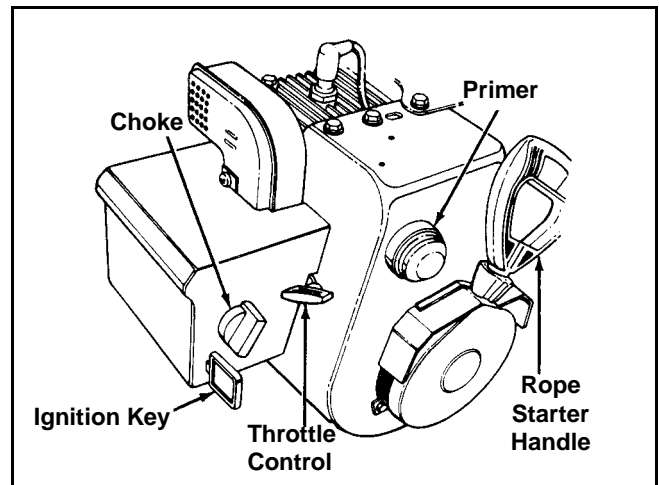

Figure 7

SECTION 5: OPERATING YOUR SNOW THROWER

Gas And Oil Fill-up

IMPORTANT: Although your snow thrower comes shipped with oil already in the engine, you **MUST** check the engine oil level as instructed in the separate engine manual packed with your unit **BEFORE** starting the engine for the first time. **Read instructions carefully**

Service the engine with gasoline and oil as instructed in the separate engine manual packed with your snow thrower. **Read instructions carefully.**



WARNING: Never fill fuel tank indoors, with engine running or while engine is hot. Do not smoke when filling fuel tank.

Electric Starter



WARNING: The electric starter is equipped with a three-wire power cord and plug, and is designed to operate on 120 volt AC household current. It must be properly grounded at all times to avoid the possibility of electric shock which may be injurious to the operator. Follow all instructions carefully. Determine that your house wiring is a three-wire grounded system. Ask a licensed electrician if you are not certain. If your house wiring system is not a three-wire grounded system, do not use this electric starter under any conditions. If your system is grounded and a three-hole receptacle is not available at the point your starter will normally be used, one should be installed by a licensed electrician.

- When connecting the power cord, always connect cord to starter on engine first, then plug the other end into a three-hole grounded receptacle.
- When disconnecting the cord, always unplug the end from the three-hole grounded receptacle first.

To Start Engine

IMPORTANT: If unit shows any sign of motion (traction or augers) with the controls disengaged, shut engine off immediately. Readjust as instructed under the heading Final Adjustments in Section 3 of this manual.

- Attach spark plug wire to spark plug.
- Make certain the fuel shut-off valve is in the open (vertical) position.
- Make certain that both the auger control and the traction control are in the disengaged (released) position.
- Move throttle control up to FAST position. Insert ignition key into slot. See Figure 7. Be certain it snaps into place. **Do not** turn the key.
- Rotate choke knob to FULL choke position (cold engine start). If engine is warm, place choke in OFF position instead of FULL.
- **Electric Start Only:** Connect power cord to switch box on engine. Plug the other end of power cord into a three-hole, grounded 120 volt AC receptacle.
- **Recoil Start Only:** Push primer button two or three times when using recoil starter. If engine is warm, push primer button once only. See Figure 7.

NOTE: Always cover vent hole in primer button when pushing. Additional priming may be necessary for first start if temperature is below 15°F.

- **Electric Start:** Do NOT prime engine. Push starter button on top of the engine to crank the engine. When engine starts, release starter button.
- **Recoil Start:** Grasp starter handle (see Figure 7) and pull rope out slowly, until it pulls slightly harder. Let rope rewind slowly. Pull starter handle rapidly. Do not allow handle to snap back. Allow it to rewind slowly while keeping a firm hold on the starter handle.
- As engine warms up and begins to operate evenly, rotate choke knob slowly to OFF position. If engine falters, return to FULL choke, then slowly move to OFF position.

To Stop Engine

- Run engine for a few minutes before stopping to help dry off any moisture on the engine.
- To help prevent possible freeze-up of starter, proceed as follows:
Electric Starter: Connect power cord to switch box on engine, then to 120 volt AC receptacle. With the engine running, push starter button and spin the starter for several seconds. The unusual sound made by spinning the starter will not harm engine or starter. Disconnect the power cord from receptacle first, and then from switch box.
Recoil Starter (Optional Instructions): With engine running, pull starter rope with a rapid, continuous full arm stroke three or four times. Pulling the starter rope will produce a loud clattering sound, which is not harmful to the engine or starter.
- To stop engine, remove the ignition key. Do not turn key. Disconnect the spark plug wire from the spark plug to prevent accidental starting while equipment is unattended.

NOTE: Do not lose ignition key. Keep it in a safe place. Engine will not start without the ignition key.

- Wipe all snow and moisture from the carburetor cover in the area of the control levers. Also, move control levers back and forth several times. Leave throttle control lever in the STOP or OFF position. Leave choke control in the FULL choke position.

To Engage Drive

- With the engine running near top speed, move shift lever into one of the six FORWARD positions or two REVERSE positions. Select a speed appropriate for the snow conditions that exist.

NOTE: Use the slower speeds until you are familiar with the operation of the snow thrower.

- Squeeze the traction control against the right handle and the snow thrower will move. Release it and the drive motion will stop.

IMPORTANT: NEVER move shift lever without first releasing the traction control. Doing so will cause premature wear to drive system's friction wheel rubber.

To Engage Augers

To engage the augers and start the snow throwing action, squeeze the auger control against the left handle.

To disengage power to the augers, release both the auger control and the traction control, if engaged,

NOTE: The auger control can also be locked so you can turn the chute directional control without interrupting the snow throwing process. Refer to Traction Control/ Auger Control Lock in Section 4 of this manual.

Tire Chains (Optional Equipment)

Tire chains should be used whenever extra traction is needed. Call our Customer Support Department as instructed on Page 2 of this manual for information regarding availability of tire chains and other optional accessories for your snow thrower.

Operating Tips

NOTE: Allow the engine to warm up for a few minutes as the engine will not develop full power until it reaches operating temperature.



WARNING: Temperature of muffler and surrounding areas may exceed 150°F. Avoid these areas.

- Set the skid shoes 1/4" below the shave plate for normal usage. The skid shoes may be adjusted upward (to lower the shave plate) for hard-packed snow. Adjust downward (to raise the shave plate) when using on gravel or crushed rock.
- Remove snow immediately after it falls.
- Discharge snow downwind whenever possible.
- Slightly overlap each previous cleared path.
- Follow the precautions found under the heading To Stop Engine to prevent possible freeze-up.
- Clean the snow thrower thoroughly after each use.

SECTION 6: MAKING ADJUSTMENTS



WARNING: NEVER attempt to clean chute or make any adjustments while engine is running.

Chute Assembly Adjustment

The distance snow is thrown can be adjusted by adjusting the angle of the chute assembly. The sharper the angle, the shorter the distance snow is thrown. To adjust the chute assembly, loosen the wing knob found on the left side of the chute and pivot the upper portion of the chute. Retighten the wing knob once the desired position is reached. See Figure 8.

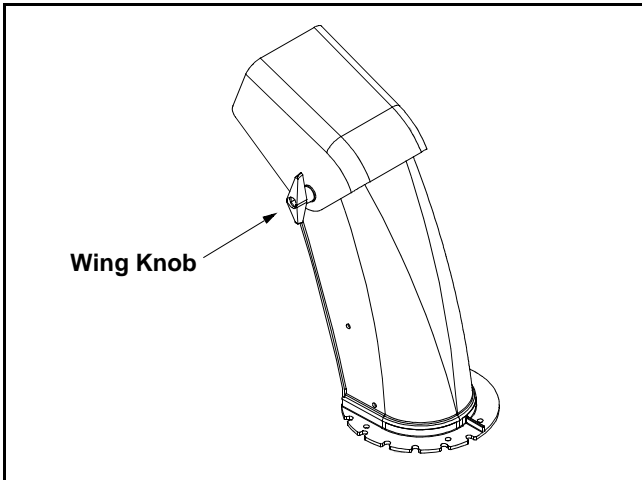

Figure 8

Chute Directional Control Support Bracket Adjustment

If the spiral at the base of the chute directional control isn't fully engaging with the notches in the lower chute assembly, the support bracket can be adjusted inward or outward as follows:

- Loosen, but do NOT remove the two hex nuts which secure the chute directional control support bracket to the snow thrower housing. See Figure 9.

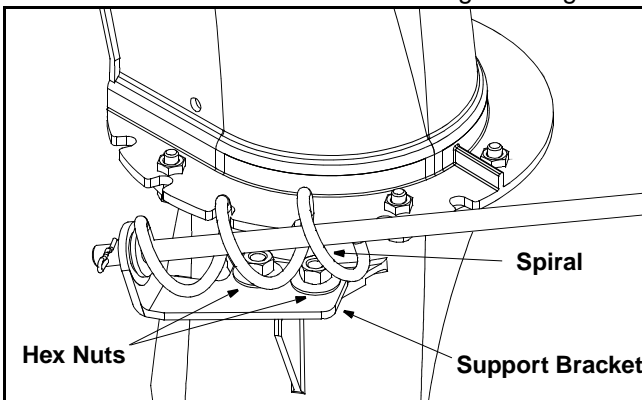

Figure 9

- Adjust the support bracket inward or outward so that the spiral is fully engaged in the notches on the chute before retightening the hex nuts.

Auger Control Adjustment

Refer to the information found under the heading Final Adjustments in Section 3 of this manual to adjust the auger control.

Skid Shoe Adjustment

The space between the shave plate and the ground can be adjusted by raising or lowering the skid shoes. Refer to Skid Shoe Adjustment in Section 3 of this manual.

Traction Control Adjustment

Refer to the information found under the heading Final Adjustments in Section 3 of this manual to adjust the traction control. If you are uncertain that you have reached the correct adjustment, proceed as follows:



WARNING: Drain the gasoline out of your snow thrower's engine, or place a piece of plastic film under the gas cap to avoid spillage BEFORE beginning to perform this adjustment.

- Tip the snow thrower forward, allowing it to rest on the auger housing.
- Remove the frame cover underneath the snow thrower by removing six self-tapping screws.

With the traction control released, there must be clearance between the friction wheel and the drive plate in all positions of the shift lever.

With the traction control engaged, the friction wheel must contact the drive plate. See Figure 10.

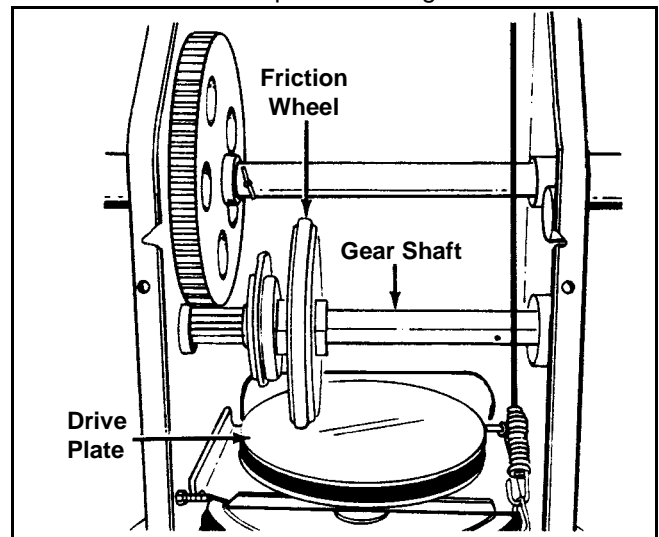

Figure 10

If adjustment is necessary:

- Loosen the jam nut on the traction drive cable and thread the cable in or out as necessary.
- Retighten the jam nut to secure the cable when correct adjustment is reached.
- Reassemble the frame cover.

NOTE: If you placed plastic film under the gas cap, be certain to remove it before operating the snow thrower.

Shift Rod Adjustment

To adjust the shift rod, proceed as follows.

- Remove the hairpin clip and slide the connector up to separate the upper shift rod from the lower shift rod. See Figure 11.

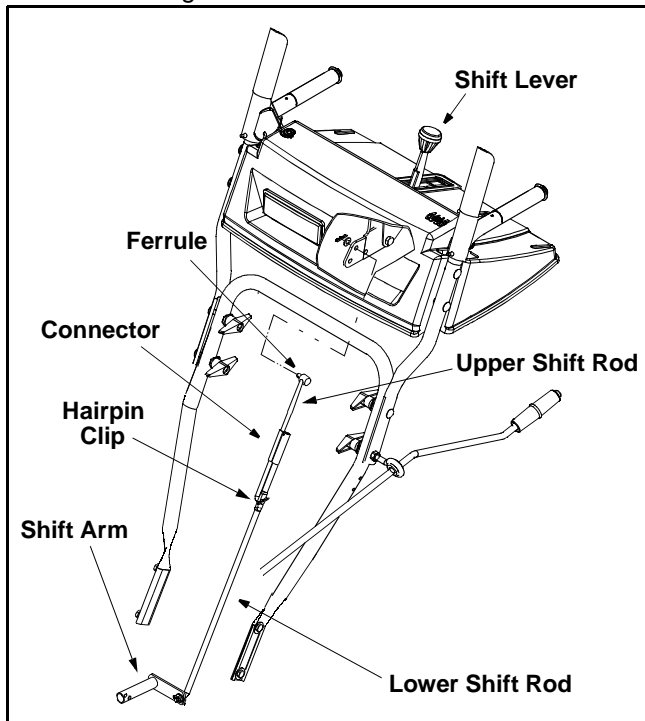

Figure 11

- Place shift lever in sixth (6) position.
- Rotate the shift arm counterclockwise (from the operator's position) as far as it will go.
- Thread the upper shift rod downward until the elbow on its lower end aligns with the hole found in the lower shift rod.

- Reconnect the upper shift rod to the lower shift rod by reinserting the hairpin clip removed earlier and sliding the connector back down into place.

IMPORTANT: Make certain to check for correct adjustment of the shift rod as instructed under the heading Final Adjustments in Section 3 of this manual, before operating the snow thrower.

Drive Wheels

The wheels may be adjusted for two different methods of operation. The adjustment is made by placing the click pins in one of two different holes on the right side of the unit. See Figure 12.

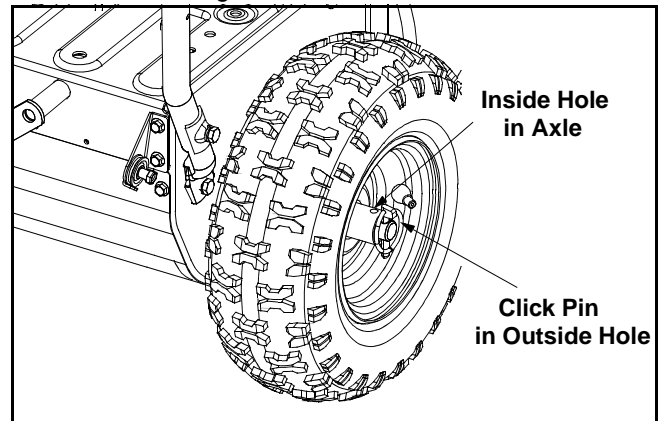

Figure 12

One Wheel Driving—Insert the click pin only through the outside hole of the axle (NOT the rim) on the right side of the snow thrower. This position gives power drive to the left wheel only, making the unit easier to maneuver.

Both Wheels Driving—Insert the click pin through the hole in the hub of the rim and the INSIDE hole on the snow thrower's right axle. This position is good for heavy snow as there is power drive in both wheels.

IMPORTANT: NEVER operate the snow thrower with the click pin inserted through both the RIM and the OUTSIDE HOLE in the axle. Doing so can result in serious damage to the drive system.

SECTION 7: MAINTAINING YOUR SNOW THROWER

Lubrication



WARNING: Disconnect the spark plug wire and ground against the engine before performing any maintenance procedures.

Engine

Refer to the separate engine manual packed with your unit for all engine lubrication instructions.

IMPORTANT: When following instructions in separate engine manual for draining oil, be sure to protect frame to avoid oil dripping onto transmission parts.

Traction Control / Auger Control Lock

The cams on the ends of the control rods which interlock the traction drive and auger drive clutches must be lubricated at least once a season or every twenty-five hours of operation. The cams can be accessed beneath the handle panel. Use a multi-purpose automotive grease.

Gear Shaft

Lubricate the gear shaft with 6-n-1 grease at least once a season or after every 25 hours of operation (available at auto parts stores, or order part number 737-0170). Refer to Figure 10.

Wheels

- Oil or spray lubricant into plastic wheel bearings inside the wheel hubs at least once a season. Remove wheels, clean and coat axles with a multi-purpose automotive grease. See Figure 13.

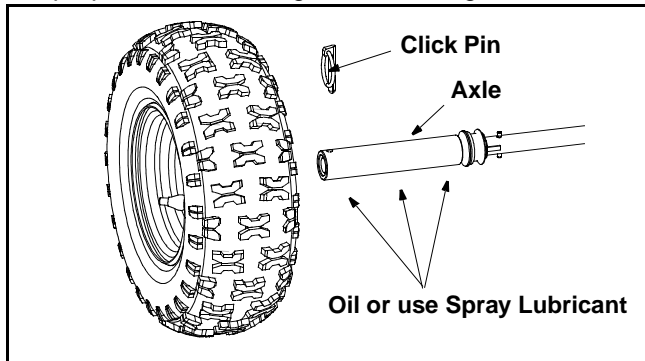

Figure 13

Gear Shaft

Lubricate the gear shaft with 6-n-1 grease at least once a season or after every 25 hours of operation (available at auto parts stores, or order part number 737-0170). Refer to Figure 10.

IMPORTANT: Keep all grease and oil off of the rubber friction wheel and aluminum drive plate.

Auger Shaft

- At least once a season, remove the shear bolts on the auger shaft. Oil or spray lubricant inside and on the plastic bearings on the shaft. See Figure 14.

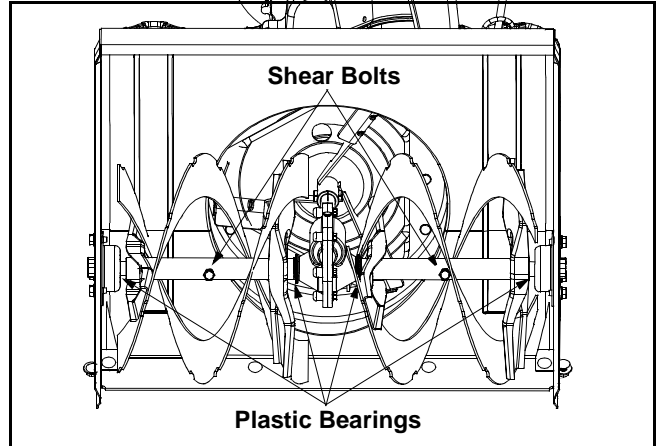

Figure 14

Drive and Shifting Mechanism

At least once a season or after every 25 hours of operation, remove rear cover. Lubricate any chains, sprockets, gears, bearings, shafts, and shifting mechanism at least once a season. Use engine oil or a spray lubricant. **Avoid getting oil on rubber friction wheel and aluminum drive plate.** Refer to Figure 10.

Chute Directional Control

The spiral on the end of the chute directional control and the base of the discharge chute itself should be lubed with multi-purpose automotive grease once a season. See Figure 15.

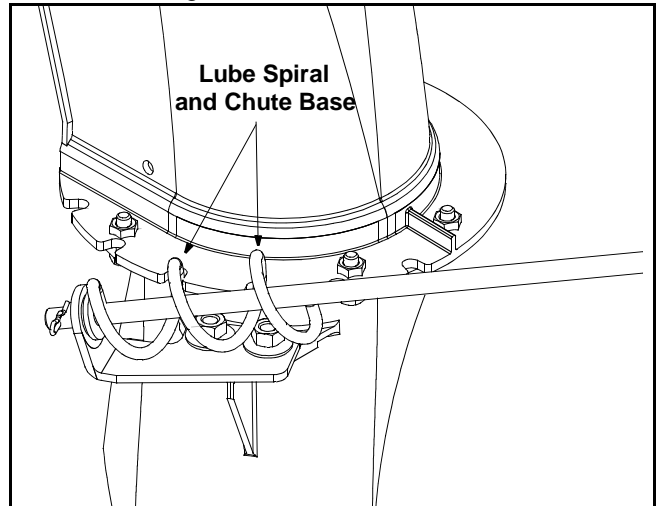

Figure 15

SECTION 8: SERVICE



WARNING: Disconnect the spark plug wire and ground against the engine before performing any repairs or maintenance.

Engine

Refer to the separate engine manual packed with your unit for all engine related maintenance procedures.

Belt Removal And Replacement



WARNING: Disconnect the spark plug wire from the spark plug and ground.

Auger Belts

- Remove the plastic belt cover by removing the two self-tapping screws. See Figure 16.

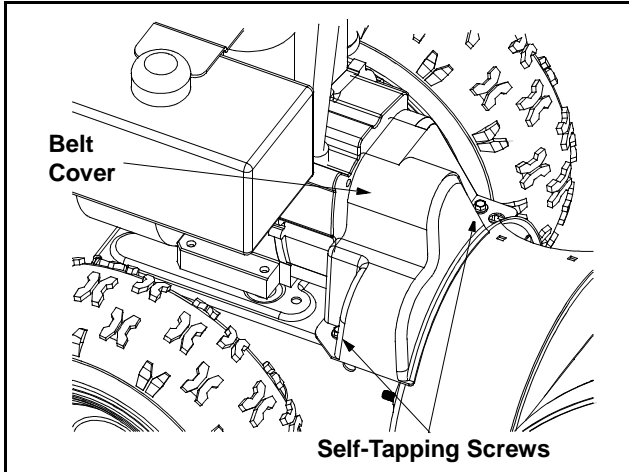

Figure 16

- Drain the gasoline from the snow thrower.
- Tip the snow thrower forward so that it rests on its auger housing and remove six self-tapping screws from the frame cover underneath the snow thrower.
- Roll the belt off the engine pulley. See Figure 17.

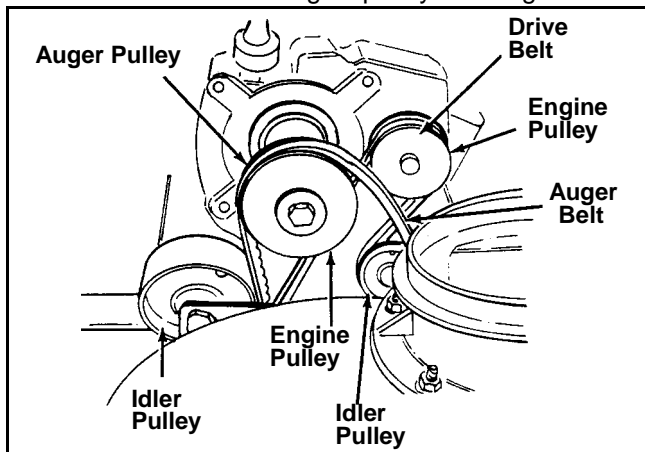

Figure 17

- Unhook the idler spring from the hex bolt on the auger housing. See Figure 18.

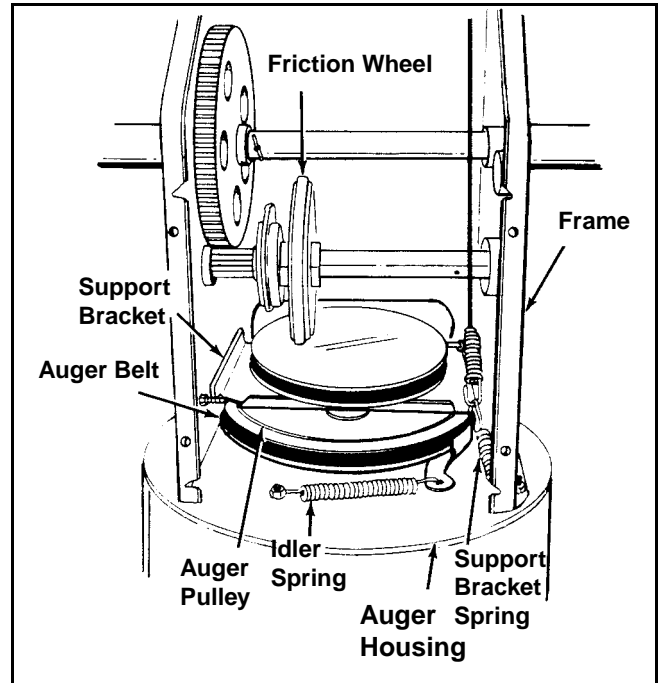

Figure 18

- Back out the stop bolt until the support bracket rests on the upper auger pulley. See Figure 19.

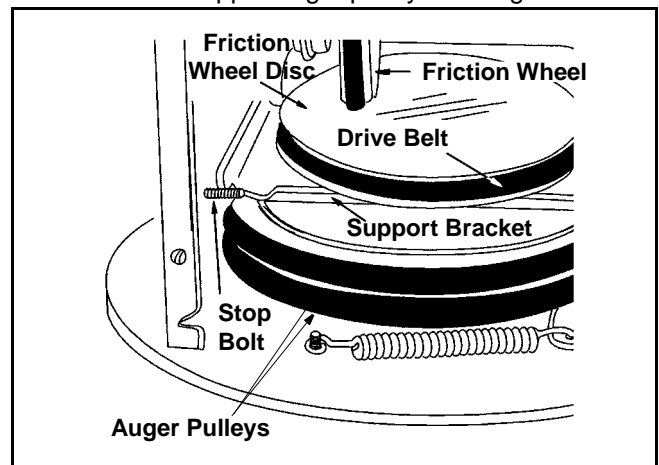

Figure 19

NOTE: Loosening the six nuts that connect the frame to the auger housing may aid in belt removal.

- Lift the rear auger belt from the auger pulley, and slip belt between the support bracket and the auger pulley. See Figure 18. Repeat this step for the front auger belt.
- Replace both auger drive belts by following instructions in reverse order.

Drive Belt

- Follow the first four steps of the instructions for servicing the auger belts.
- Pull idler pulley up, and lift belt off engine pulley and friction wheel disc. See Figure 17.
- Back out the stop bolt until the support bracket rests on the auger pulley. See Figure 19.
- Slip belt between friction wheel and friction wheel disc. See Figure 19. Remove and replace belt.
- Reassemble following the instructions in reverse order.

NOTE: The support bracket must rest on the stop bolt after the new belt has been assembled. See Figure 19.

Servicing Friction Wheel Rubber

The rubber on the friction wheel is subject to wear and should be checked after 25 hours of operation, and periodically thereafter. Replace the friction wheel rubber if any signs of wear or cracking are found.

- Drain the gasoline from the snow thrower.
- Tip the snow thrower up and forward, so that it rests on the housing.
- Remove six self-tapping screws from the frame cover underneath the snow thrower.
- Remove the click pins which secure the wheels, and remove the wheels from the axle.
- Using a 7/8" wrench to hold the shaft, loosen, but do not completely remove, the hex nut and bell washer on the left end of gear shaft. See Figure 20.

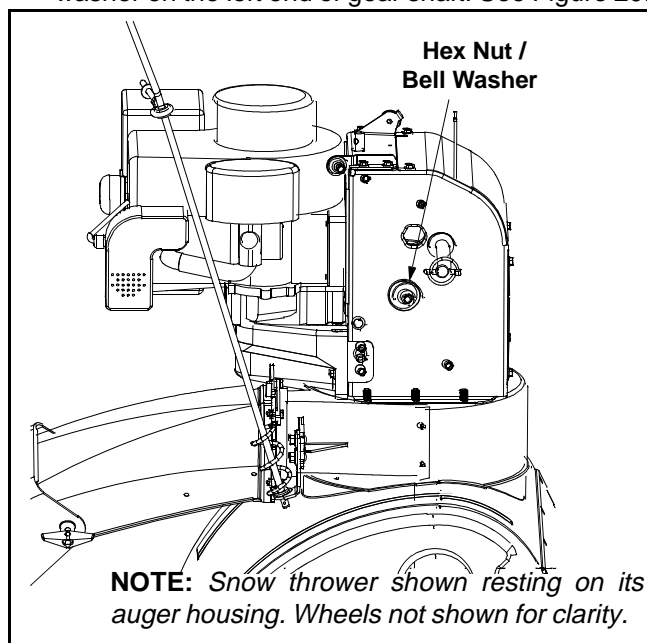

Figure 20

- Lightly tap the hex nut to dislodge the ball bearing from the right side of frame before removing the hex nut and bell washer from left end of shaft.
- Move the gear shaft to the right and slide the friction wheel assembly from the shaft.

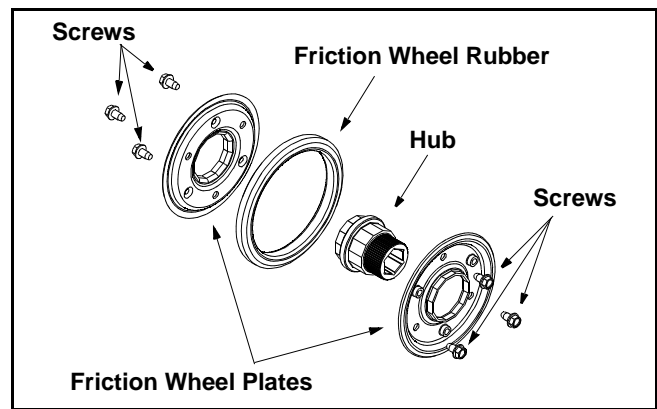

Figure 21

- Remove the six screws from the friction wheel assembly (three from each side). Remove the friction wheel rubber from between the friction wheel plates. See Figure 21.
- Reassemble new friction wheel rubber to the friction wheel plates and hub, tightening the six screws in rotation and with equal force.
- Position the friction wheel assembly up onto the pin of the shift rod assembly, and slide the shaft through the assembly. Reassemble in reverse order.

Shave Plate and Skid Shoes

The shave plate and skid shoes on the bottom of the snow thrower are subject to wear. They should be checked periodically and replaced when necessary. To remove the skid shoes, proceed as follows:

- Remove the four carriage bolts, bell washers and hex nuts which attach them to the snow thrower.
- Reassemble new skid shoes with the four carriage bolts, bell washers (cupped side goes against skid shoes) and hex nuts. Make certain the skid shoes are adjusted to be level.

To remove shave plate, remove the carriage bolts, Belleville washers and hex nuts which attach it to the snow thrower housing. Reassemble new shave plate, making sure heads of the carriage bolts are to the inside of the housing. Tighten securely.

Augers

The augers are secured to the spiral shaft with two shear bolts and hex lock nuts. Refer to Figure 14. If you hit a foreign object or ice jam, the snow thrower is designed so that the bolts may shear. If the augers will not turn, check to see if the bolts have sheared.

IMPORTANT: NEVER replace the auger shear bolts with standard hex bolts. Any damage to the auger gearbox or other components as a result of doing so will NOT be covered by your snow thrower's warranty.

SECTION 9: OFF-SEASON STORAGE



WARNING: Never store engine with fuel in tank indoors or in poorly ventilated areas, where fuel fumes may reach an open flame, spark or pilot light as on a furnace, water heater, clothes dryer or other gas appliance.

- If unit is to be stored over 30 days, prepare engine for storage as instructed in the separate engine manual packed with your unit.
- Remove all debris from the exterior of the engine and equipment.

- Follow the lubrication recommendations found in Section 7 of this manual.
- Always store the snow thrower in a clean, dry area.

NOTE: *When storing any type of power equipment in an unventilated or metal storage shed, care should be taken to rust proof the equipment. Using a light oil or silicone, coat the equipment, especially any chains, springs, bearings and cables.*

SECTION 10: TROUBLESHOOTING

Problem	Cause	Remedy
Engine fails to start	<ol style="list-style-type: none"> 1. Fuel tank empty, or stale fuel. 2. Blocked fuel line. 3. Choke not in ON position 4. Faulty spark plug. 5. Safety key not in ignition switch on engine. 6. Spark plug wire disconnected. 7. Primer button not being used properly. 8. Fuel shut-off valve closed. 	<ol style="list-style-type: none"> 1. Fill tank with clean, fresh gasoline. Fuel becomes stale after thirty days unless a fuel stabilizer is used. 2. Clean the fuel line. 3. Move switch to ON position 4. Clean, adjust gap or replace. 5. Insert the key fully into the switch. 6. Connect spark plug wire. 7. Refer to the engine manual for proper priming instructions. 8. Open fuel shut-off valve.
Engine runs erratic	<ol style="list-style-type: none"> 1. Unit running on CHOKE. 2. Blocked fuel line or stale fuel. 3. Water or dirt in fuel system. 4. Carburetor out of adjustment. 	<ol style="list-style-type: none"> 1. Move choke lever to OFF position. 2. Clean fuel line. Refill with fresh fuel. 3. Drain fuel tank and carburetor. Refill with fresh fuel. 4. Refer to the engine manual packed with your unit or have carburetor adjusted by an authorized engine service dealer.
Loss of power	<ol style="list-style-type: none"> 1. Spark plug wire loose. 2. Gas cap vent hole plugged. 3. Exhaust port plugged. 	<ol style="list-style-type: none"> 1. Connect and tighten spark plug wire. 2. Remove ice and snow from gas cap. Be certain vent hole is clear. 3. Refer to the Maintenance section of the engine manual.
Engine overheats	<ol style="list-style-type: none"> 1. Carburetor not adjusted properly. 	<ol style="list-style-type: none"> 1. Refer to the engine manual or have the carburetor adjusted by an authorized engine service dealer.
Excessive vibration	<ol style="list-style-type: none"> 1. Loose parts or damaged auger. 	<ol style="list-style-type: none"> 1. Stop engine immediately and disconnect spark plug wire. Tighten all bolts and nuts. If vibration continues, have unit serviced by an authorized service dealer.
Unit fails to propel itself	<ol style="list-style-type: none"> 1. Traction control cable in need of adjustment. 2. Drive belt loose or damaged. 	<ol style="list-style-type: none"> 1. Adjust traction control cable. Refer to Section 6 of this manual. 2. Replace drive belt. Refer to Section 8 of this manual.
Unit fails to discharge snow	<ol style="list-style-type: none"> 1. Discharge chute clogged. 2. Foreign object lodged in auger. 3. Auger control cable in need of adjustment. 4. Auger belt loose or damaged. 	<ol style="list-style-type: none"> 1. Stop engine immediately and disconnect spark plug wire. Clean chute area and auger housing. 2. Stop engine immediately and disconnect spark plug wire. Remove object from auger. 3. Adjust auger control cable. Refer to Section 6 of this manual. 4. Refer to Section 8 of this manual.

SECTION 11: PARTS LIST

Model 663

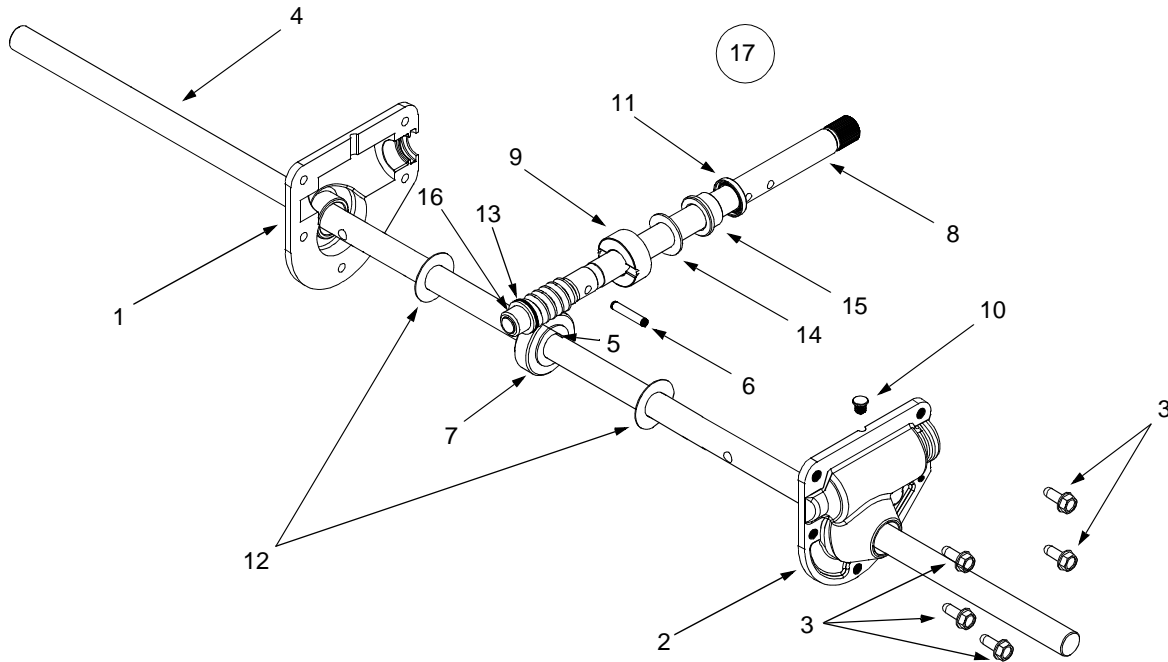

Ref. No.	Part No.	Part Description
1.	618-0123	RH Housing
2.	618-0124	LH Housing
3.	710-0642	Self Tapping Screw, 1/4-20 x .75
4.	711-0910	Spiral Axle, 28"
5.	714-0161	Hi-Pro Key, 3/16 x 5/8
6.	715-0143	Spring Spirol Pin, .25 x 1.25
7.	717-0528	Worm Gear, 20-tooth
8.	717-0526	Worm Shaft
9.	718-0186	Thrust Collar
10.	721-0325	Grease Plug
11.	721-0327	Grease Seal
12.	736-0351	Flat Washer, .76 x 1.5 x .030
13.	736-0369	Flat Washer, .508 x 1.0 x .020
14.	736-0445	Flat Washer, .76 x 1.5 x .060
15.	741-0662	Flange Bearing, .75 x 1.0 x .59
16.	741-0663	Flange Bearing, .503 ID x .75 OD
17.	618-0122	Gear Assembly Complete, 28"
—	737-0168	Grease (Two Ounces)

Model 663

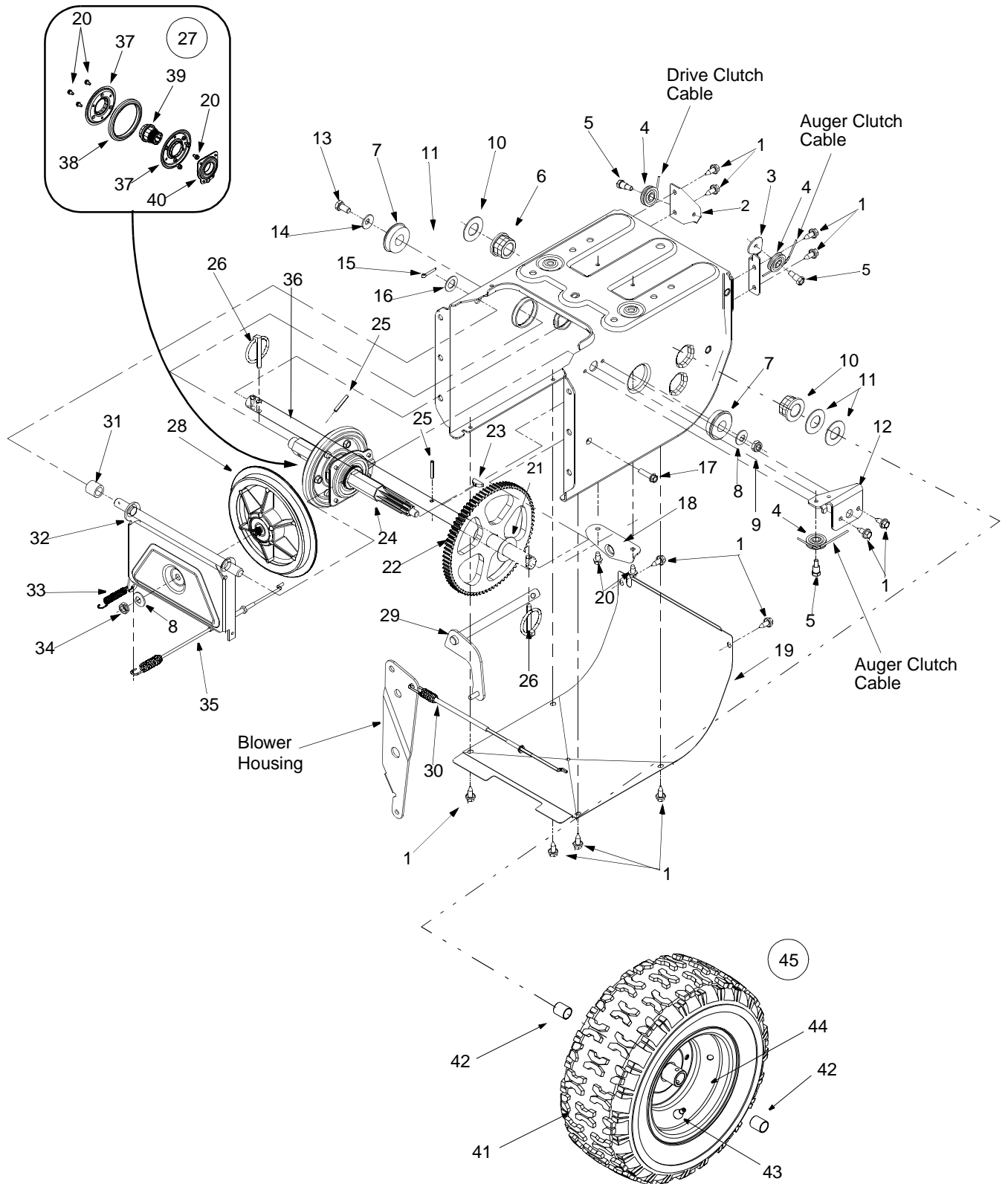

Model 663

Ref. No.	Part No.	Part Description	Ref. No.	Part No.	Part Description
1.	710-1652	Hex Screw	24.	717-1444	7-Tooth Shaft
2.	784-5688	Drive Cable Guide Bracket	25.	715-0249	Roll Pin
3.	784-5687	Auger Clutch Cable Bracket	26.	714-0143	Clik Pin
4.	756-0625	Roller Cable	27.	684-0042B	Friction Wheel Assembly
5.	738-0924	Hex Screw 1/4-28	28.	656-0012A	Friction Disc Wheel
6.	684-0030	Frame Assembly	29.	684-0013B	Wheel Shift Rod Assembly
7.	741-0563	Ball Bearing	30.	746-0897	Drive Cable
8.	736-0105	Bell Washer	31.	748-0190	Spacer
9.	712-0116	Lock Jam Nut	32.	684-0021	Friction Wheel Bracket Ass'y
10.	741-0598	Hex Flange Bearing	33.	732-0264	Extension Spring
11.	736-0188	Flat Washer	34.	712-0711	Jam Nut, 3/8-24
12.	784-5689A	Front Support Guide Bracket	35.	746-0898	Drive Cable
13.	710-0538	Lock Hex Screw	36.	738-0830	Axle
14.	736-0242	Bell Washer .340 ID x .872 OD	37.	717-1445	Gear
15.	714-0474	Cotter Pin	38.	714-0126	Key
16.	736-0160	Flat Washer .536 ID x .930 OD	39.	717-1444	7-Tooth Shaft
17.	710-0788	Hex Washer Screw 1/4-20	40.	618-0063	Friction Wheel Bearing
18.	784-5590	Frame Shift Bracket	41.	734-1525	Tire Only, 16 x 6.5 x 8
19.	784-5638	Frame Cover	42.	741-0401	Sleeve Bearing
20.	710-0599	Hex Washer Screw 1/4-20	43.	734-0255	Air Valve
21.	736-0351	Flat Washer .760 ID x .50 OD	44.	734-1711	Wheel Rim
22.	717-1445	Gear	45.	734-1712	Wheel Ass'y (Incl. Ref. 41-44)
23.	714-0126	Key			

Model 663

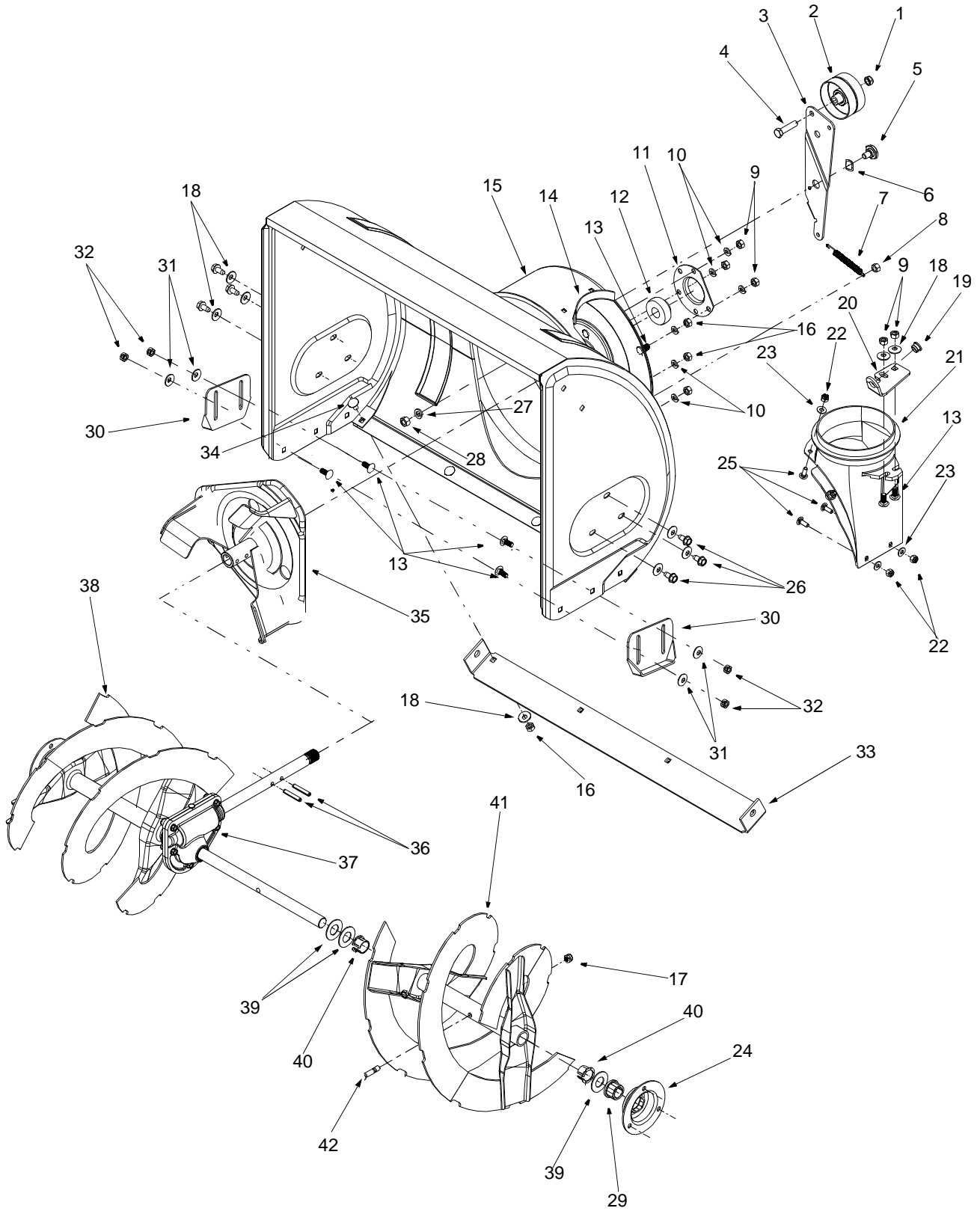

Model 663

Ref. No.	Part No.	Part Description	Ref. No.	Part No.	Part Description
1.	712-0116	Lock Jam Nut 3/8-24	23.	736-0463	Flat Washer
2.	756-0178	Flat Idler	24.	784-5618	Bearing Housing
3.	784-5632A	Auger Idler Arm	25.	710-0703	Carriage Screw 1/4-20 x .75
4.	710-0459A	Hex Cap Screw 3/8-24 x 1.50	26.	710-0604	Hex Washer Screw 5/16-18
5.	738-0281	Shoulder Screw	27.	736-0169	Lock Washer 3/8
6.	736-0174	Wave Washer	28.	712-0798	Hex Nut 3/8-16
7.	732-0611	Extension Spring	29.	741-0245	Hex Flange Bearing
8.	712-3068	Hex Nut 5/16-18	30.	784-5580	Skid Shoe
9.	712-3010	Hex Nut 5/16-18	31.	736-0242	Bell Washer
10.	736-0119	Lock Washer 5/16	32.	712-3010	Hex Nut 5/16-18
11.	05931	Housing	33.	784-5582A	27.66" Shave Plate
12.	741-0309	Ball Bearing	34.	710-0260	Carriage Bolt 5/16-18 x .62
13.	710-0451	Carriage Bolt 5/16-18 x .75	35.	684-0065	Impeller Assembly
14.	705-5226	Chute Reinforcement	36.	715-0114	Pin
15.	684-0041C	28" Housing Assembly	37.	618-0122	Gear Assembly
16.	712-3010	Hex Nut 5/16-18	38.	605-5196A	Spiral RH
17.	712-0429	Lock Nut 5/16-18	39.	736-0188	Flat Washer
18.	736-0242	Bell Washer	40.	741-0493A	Flange Bushing
19.	741-0475	Bushing	41.	605-5197A	Spiral LH
20.	784-5647	Chute Crank Bracket	42.	710-0890A	Shear Bolt 5/16-18 x 1.5
21.	731-1379A	Chute Adapter	43.	736-0231	Flat Washer, .344 x 1.12 x .87
22.	712-0324	Hex Lock Nut 1/4-20			

Model 663

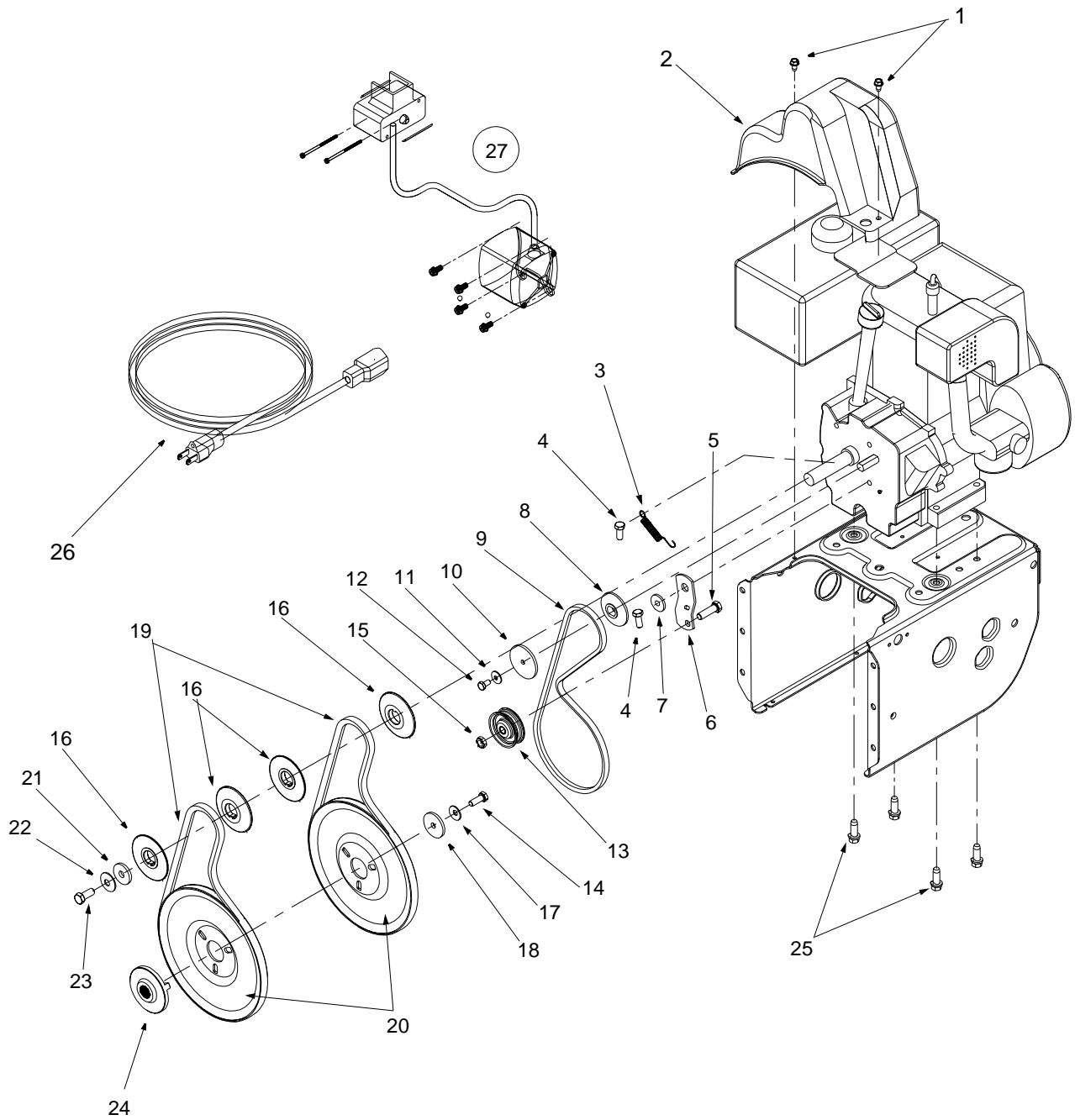

Model 663

Ref. No.	Part No.	Part Description
1.	710-0599	Hex Washer Screw 1/4-20 x .50
2.	731-1324	Belt Cover
3.	732-0710	Extension Spring
4.	710-0627	Hex Screw 5/16-24 x .75
5.	710-3005	Hex Cap Screw 3/8-16 x 1.25
6.	05896A	Drive Clutch Idler Bracket
7.	748-0234	Shoulder Spacer
8.	756-0987	Pulley Half
9.	754-0346	V-Belt
10.	756-0986	Pulley Half
11.	736-0270	Bell Washer
12.	710-0230	Hex Cap Screw 1/4-28 x .50
13.	756-0313	Flat Idler
14.	710-1245	Lock Hex Cap Screw 5/16-24
15.	712-0181	Lock Jam Nut 3/8-16
16.	756-0569	Pulley Half
17.	736-0242	Bell Washer
18.	736-0505	Flat Washer
19.	754-0430	Belt
20.	756-0967	Auger Pulley
21.	736-0247	Flat Washer 3/8 x 1.25 OD
22.	736-0331	Bell Washer
23.	710-0696	Hex Cap Screw 3/8-24
24.	748-0360	Adapter Pulley
25.	710-0654A	Hex Screw 3/8-16 x 1.0
26.	629-0071	Extension Cord
27.	OEM-390-987	Electric Start Kit

IMPORTANT: For a proper working machine, use Factory Approved Parts.

V-BELTS are specially designed to engage and disengage safely. A substitute (non OEM) V-Belt can be dangerous by not disengaging completely

Model 663

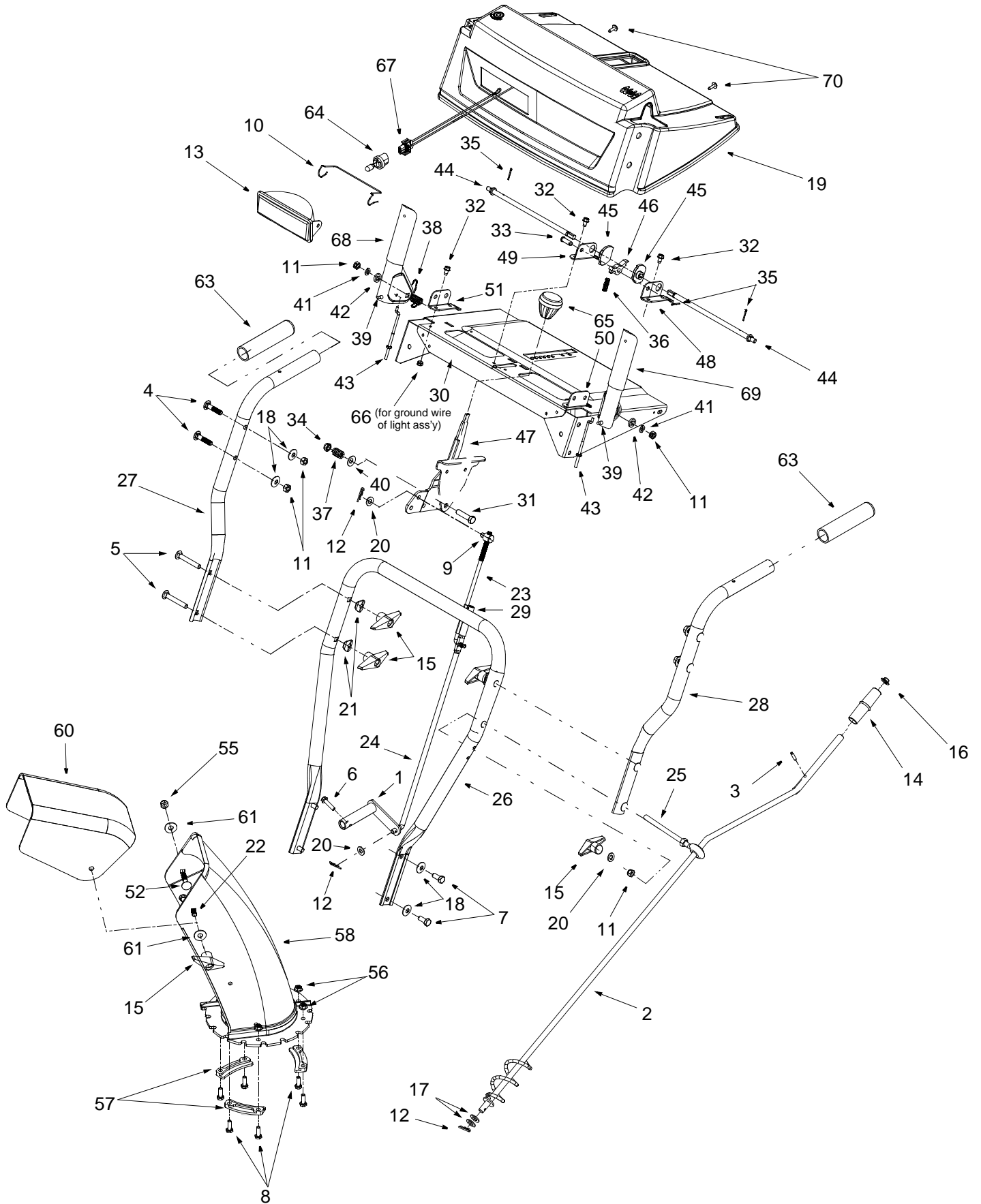

Model 663

Ref. No.	Part No.	Part Description	Ref. No.	Part No.	Part Description
1.	684-0008A	Shift Arm Assembly	36.	732-0145	Compression Spring, .36 x 1.0
2.	684-0022	Chute Crank Ass'y	37.	732-0193	Comp. Spring, .39 x .6 x .88
3.	715-0138	Rolled Pin	38.	732-0746	Torsion Spring, .44 x .8
4.	710-0262	Carriage Bolt, 5/16-18 x 1.5	39.	735-0199A	Rubber Bumper
5.	710-0449	Carriage Bolt, 5/16-18 x 2.25	40.	736-0105	Bell Washer, .401 x .87 x .063
6.	710-0788	Self Tapping Screw, 1/4-20 x 1	41.	736-0119	Lock Washer, 5/16
7.	710-3008	Hex Cap Screw, 5/16-18 x .75	42.	736-0509	Special Washer, .35 x .72 x .13
8.	710-3015	Hex Cap Screw, 1/4-20 x .75	43.	746-0778	Cable "Z" Fitting
9.	711-0677	Ferrule, 5/16-18 x .312	44.	747-0877	Cam Rod
10.	747-1136	Headlamp Retainer	45.	748-0362	Cam Handle Lock
11.	712-3010	Hex Nut, 5/16-18	46.	748-0363	Handle Lock Pawl
12.	714-0104	Internal Cotter Pin	47.	784-5619A	Shift Handle
13.	725-1672	Lens Assembly / Lamp Housing	48.	784-5679	LH Handle Support Bracket
14.	720-0201A	Chute Crank Knob	49.	784-5680	RH Handle Support Bracket
15.	720-0284	Wing Knob, 5/16-18	50.	784-5681	LH Handle Support Bracket
16.	726-0100	Push Cap, 3/8	51.	784-5682	RH Handle Support Bracket
17.	736-0185	Flat Washer, .375 x .738 x .063	52.	710-0451	Carriage Bolt, 5/16-18 x .75
18.	736-0242	Bell Washer, .34 x .872	53.	710-0805	Hex Cap Screw, 5/16-18 x 1.5
19.	731-1341A	Plastic Handle Panel (Red)	54.	710-0896	Screw, 1/4-14 x .625
20.	736-0275	Flat Washer, .344 x .688 x .065	55.	712-0429	Hex Lock Nut, 5/16-18
21.	736-0451	Saddle Washer, .32 x .93	56.	712-3027	Hex Flange Lock Nut, 1/4-20
22.	710-0276	Carriage Screw, 5/16-18 x 1	57.	731-0851A	Lower Chute Flange Keeper
23.	747-0620A	Upper Shift Rod	58.	731-1300A	Lower Chute
24.	747-0621	Lower Shift Rod	59.	731-1313C	Chute Tilt Cable Guide
25.	747-0697	Eyebolt	60.	731-1320	Upper Chute
—	735-0234	Eyebolt Grommet (Not Shown)	61.	736-0159	Washer, 5/16
26.	749-0951	Lower Handle	62.	736-0506	Special Washer, .28 x 1.2 x .06
27.	749-0952	RH Handle (Upper)	63.	720-0274	Handle Grip
28.	749-0953	LH Handle (Upper)	64.	725-1658	Halogen Lamp, 12-volt, 27 Watt
29.	750-0963	Shift Rod Connector	65.	720-0232	Plastic Knob
30.	684-0103	Handle Panel Assembly	66.	712-0271	Hex Sems Nut, 1/4-20
31.	710-0459A	Hex Cap Screw, 3/8-24 x 1.5	67.	629-0059	Halogen Light Harness
32.	710-0599	Self Tapping Screw, 1/4-20 x .5	68.	684-0036	RH Engagement Handle Ass'y
33.	711-0653	Clevis Pin	69.	684-0059	LH Engagement Handle Ass'y
34.	712-0116	Jam Nut, 3/8-24	70.	710-1003	Special Screw, #10-16 x .625
35.	714-0507	Cotter Pin, 3/32 x .75			

MANUFACTURER'S LIMITED WARRANTY

The limited warranty set forth below is given by MTD PRODUCTS INC ("MTD") with respect to new merchandise purchased and used in the United States, its possessions and territories.

MTD warrants this product against defects in material and workmanship for a period of two (2) years commencing on the date of original purchase and will, at its option, repair or replace, free of charge, any part found to be defective in material or workmanship. This limited warranty shall only apply if this product has been operated and maintained in accordance with the Operator's Manual furnished with the product, and has not been subject to misuse, abuse, commercial use, neglect, accident, improper maintenance, alteration, vandalism, theft, fire, water or damage because of other peril or natural disaster. Damage resulting from the installation or use of any accessory or attachment not approved by MTD Products Inc. for use with the product(s) covered by this manual will void your warranty as to any resulting damages.

Normal wear parts or components thereof are subject to separate terms as follows: All normal wear part or component failures will be covered on the product for a period of 90 days regardless of cause. After 90 days, but within the two year period, normal wear part failures will be covered ONLY IF caused by defects in material or workmanship of OTHER component parts. Normal wear parts and components include, but are not limited to, belts, blades, blade adapters, grass bags, rider deck wheels, seats, snow thrower skid shoes, shave plates and tires. Batteries are covered by a 90-day limited replacement warranty.

HOW TO OBTAIN SERVICE: Warranty service is available, WITH PROOF OF PURCHASE THROUGH YOUR LOCAL AUTHORIZED SERVICE DEALER. To locate the dealer in your area, please check for a listing in the Yellow Pages or contact the Customer Service Department of MTD PRODUCTS INC by calling 1-800-800-7310 or writing to P.O. Box 368022, Cleveland, Ohio 44136-9722. No product returned directly to the factory will be accepted unless prior written permission has been extended by the Customer Service Department of MTD PRODUCTS INC.

This limited warranty does not provide coverage in the following cases:

- a. The engine or component parts thereof. These items carry a separate manufacturer's warranty. Please refer to the applicable manufacturer's warranty on these items.

- b. Routine maintenance items such as lubricants, filters, blade sharpening and tune-ups, or adjustments such as brake adjustments, clutch adjustments or deck adjustments; and normal deterioration of the exterior finish due to use or exposure.
- c. Log splitter pumps, valves and cylinders have a separate one year warranty.
- d. MTD does not extend any warranty for products sold or exported outside of the United States of America, its possessions and territories, except those sold through MTD's authorized channels of export distribution.

No implied warranty, including any implied warranty of merchantability or fitness for a particular purpose, applies after the applicable period of express written warranty above as to the parts as identified. No other express warranty or guaranty, whether written or oral, except as mentioned above, given by any person or entity, including a dealer or retailer, with respect to any product shall bind MTD. During the period of the Warranty, the exclusive remedy is repair or replacement of the product as set forth above. (Some states do not allow limitations on how long an implied warranty lasts, so the above limitation may not apply to you.)

The provisions as set forth in this Warranty provide the sole and exclusive remedy arising from the sales. MTD shall not be liable for incidental or consequential loss or damages including, without limitation, expenses incurred for substitute or replacement lawn care services, for transportation or for related expenses, or for rental expenses to temporarily replace a warranted product. (Some states do not allow the exclusion or limitation of incidental or consequential damages, so the above exclusion or limitation may not apply to you.)

In no event shall recovery of any kind be greater than the amount of the purchase price of the product sold. Alteration of the safety features of the product shall void this Warranty. You assume the risk and liability for loss, damage, or injury to you and your property and/or to others and their property arising out of the use or misuse or inability to use the product.

This limited warranty shall not extend to anyone other than the original purchaser, original lessee or the person for whom it was purchased as a gift.

How State Law Relates to this Warranty: This limited warranty gives you specific legal rights, and you may also have other rights which vary from state to state.

Free Manuals Download Website

<http://myh66.com>

<http://usermanuals.us>

<http://www.somanuals.com>

<http://www.4manuals.cc>

<http://www.manual-lib.com>

<http://www.404manual.com>

<http://www.luxmanual.com>

<http://aubethermostatmanual.com>

Golf course search by state

<http://golfingnear.com>

Email search by domain

<http://emailbydomain.com>

Auto manuals search

<http://auto.somanuals.com>

TV manuals search

<http://tv.somanuals.com>