

\$1.00

OWNER'S GUIDE

ASSEMBLY • OPERATION • MAINTENANCE • PARTS

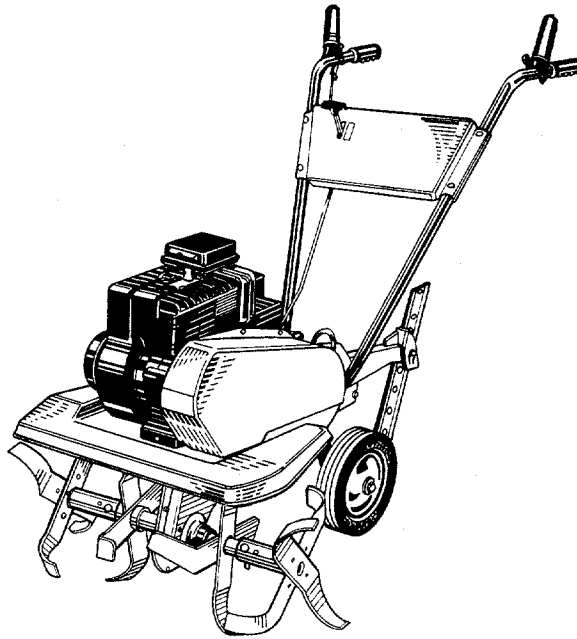

**5 H.P.
CHAIN DRIVE
TILLER**

**Model Number
219-381-000**

Important: Read Safety Rules and Instructions Carefully

INDEX

Safe Operation Practices	3
Assembly Instructions	4
Controls	8
Operation	9
How to Use Your Tiller	9
Adjustments	12
Lubrication	13
Maintenance	13
Off-Season Storage	14
Trouble Shooting Guide	15
Illustrated Parts and Parts Lists	16-19
Parts for Chain Case	20
Parts Information	Back Cover

Dear Customer,

So often throughout the year we are all in a rush to meet our daily obligations.

However, we at MTD Products Inc are taking a quick moment out to say...

"Thank you for your business."

Sincerely,
MTD PRODUCTS INC



INSTRUCTIONS GIVEN WITH THIS SYMBOL ARE FOR PERSONAL SAFETY. BE SURE TO FOLLOW THEM.

LIMITED WARRANTY

For one year from the date of original retail purchase, MTD PRODUCTS INC will either repair or replace, at its option, free of charge, F.O.B. factory or authorized service firm, any part or parts found to be defective in material or workmanship. Transportation charges for the movement of any power equipment unit or attachment are the responsibility of the purchaser. Transportation charges for any parts submitted for replacement under this warranty must be paid by the purchaser unless such return is requested by MTD PRODUCTS INC.

This warranty will not apply to any part which has become inoperative due to misuse, excessive use, accident, neglect, improper maintenance, alterations, or unless the unit has been operated and maintained in accordance with the instructions furnished. This warranty does not apply to the engine, Peerless components, motor, battery (except as noted below) or component parts thereof. Please refer to the applicable manufacturer's warranty on these items.

A battery which proves defective within ninety (90) days will be replaced without charge. After 90 days but within one year from the date of purchase, MTD will replace the defective battery for a charge of 1/12 of the current retail price of the battery for each full 30 day period between the date of purchase and the date of return.

This warranty will not apply where the unit has been used commercially.

Warranty service is available through your local authorized service dealer or distributor. If you do not know the dealer or distributor in your area, please write to the Customer Service Department of MTD.

The return of a complete unit will not be accepted by the factory unless prior written permission has been extended by MTD.

This warranty gives you specific legal rights. You may also have other rights which vary from state to state.

WARNING: This unit is equipped with an internal combustion engine and should not be used on or near any unimproved forest-covered, brush-covered or grass-covered land unless the engine's exhaust system is equipped with a spark arrester meeting applicable local or state laws (if any). If a spark arrester is used, it should be maintained in effective working order by the operator.

In the State of California the above is required by law (Section 4442 of the California Public Resources Code). Other states may have similar laws. Federal laws apply on federal lands. A spark arrester for the muffler is available through your nearest engine authorized service dealer.



To reduce the potential for any injury, comply with the following safety instructions. Failure to comply with the instructions may result in personal injury.

SAFE OPERATION PRACTICES FOR TILLERS

1. It is suggested that this manual be read in its entirety before attempting to assemble or operate this unit. Keep this manual in a safe place for future and regular reference and for ordering replacement parts.
2. Your tiller is a precision piece of power equipment, not a plaything. Therefore, exercise extreme caution at all times.
3. Read this owner's guide carefully. Be thoroughly familiar with the controls and the proper use of the equipment.
4. Never allow children to operate a power tiller. Only persons well acquainted with these rules of safe operation should be allowed to use your tiller.
5. No one should operate this unit while intoxicated or while taking medication that impairs the senses or reactions.
6. Keep the area of operation clear of all persons, particularly small children and pets.
7. Do not operate equipment when barefoot or wearing open sandals. Always wear substantial footwear.
8. Do not wear loose fitting clothing that could get caught on the tiller.
9. Do not start the engine unless the shift lever is in the neutral (N) position.
10. Do not stand in front of the tiller while starting the engine.
11. Do not place feet and hands on or near the tines when starting the engine or while the engine is running.
12. Never attempt to make a wheel or depth bar adjustment while the engine is running.
13. Do not leave the tiller unattended with the engine running.
14. Do not walk in front of the tiller while the engine is running.
15. Check the fuel before starting the engine. Gasoline is an extremely flammable fuel. Do not fill gasoline tank indoors, while the engine is running, or while the engine is still hot. Replace gasoline cap securely, and wipe off any spilled gasoline before starting the engine as it may cause a fire or explosion.
16. Do not run the engine while indoors. Exhaust gases are deadly poisonous.
17. Be careful not to touch the muffler after the engine has been running. It is hot.
18. Do not change the engine governor settings or overspeed the engine. Excessive engine speeds are dangerous.
19. Before any maintenance work is performed or adjustments are made, remove the spark plug wire and ground it on the engine block for added safety.
20. Use caution when tilling near buildings and fences. Rotating tines can cause damage or injury.
21. Before attempting to remove rocks, bricks and other objects from tines, stop the engine and be sure the tines have stopped completely. Disconnect the spark plug wire and ground to prevent accidental starting.
22. Check the tine and engine mounting bolts at frequent intervals for proper tightness.
23. Keep all nuts, bolts and screws tight to be sure the equipment is in safe working condition.
24. Never store the equipment with gasoline in the tank inside of a building where fumes may reach an open flame or spark. Allow the engine to cool before storing in any enclosure.

NOTE

This unit is shipped WITHOUT GASOLINE or OIL. After assembly, see separate engine manual for proper fuel and engine oil recommendations.

NOTE

Right and left hand is determined when standing behind the tiller in the operating position.

ASSEMBLY INSTRUCTIONS

Tools Required for Assembly:

- (1) 1/2" Wrench or Socket*
- (2) 9/16" Wrenches or Sockets*
- (2) 7/16" Wrenches or Sockets*
- (1) Adjustable Wrench
- (1) Phillips Screwdriver
- (1) Flat Blade Screwdriver

*The adjustable wrench may be used in place of one of the wrenches.

UNPACKING

Remove the tiller and loose parts from the carton. Make certain all parts and literature have been removed before the carton is discarded.

Extend all control cables and place on the floor. Be careful not to bend or kink control cables.

Parts in Carton:

- Tiller
- Handle Panel
- R.H. and L.H. Handles
- Depth Stake
- Tailpiece
- Hardware Pack

Contents of Hardware Pack: (See Figure 1)

- A (1) U-Clevis Pin
- B (3) Hairpin Clips
- C (2) Clevis Pins 3/8" Diameter
- D (2) Hex Bolts 3/8-16 x 1" Long
- E (2) Belleville Washers 3/8" I.D.
- F (2) Lock Washers 3/8" I.D.
- G (2) Hex Nuts 3/8-16 Thread
- J (1) Phillips Head Self-Tapping Screw
- K (1) Left Hand Cable Hold-Down (Black)
- L (1) Right Hand Cable Hold-Down (Brown)
- M (2) Self-Tapping Screws
- N (2) Cable Ties
- O (4) Carriage Bolts 5/16-18 x 1 3/4" Long
- P (4) Lock Washers 5/16" I.D.
- Q (4) Hex Nuts 5/16-18 Thread
- R (1) Clevis Pin 1/2" Diameter
- S (1) Spring Pin

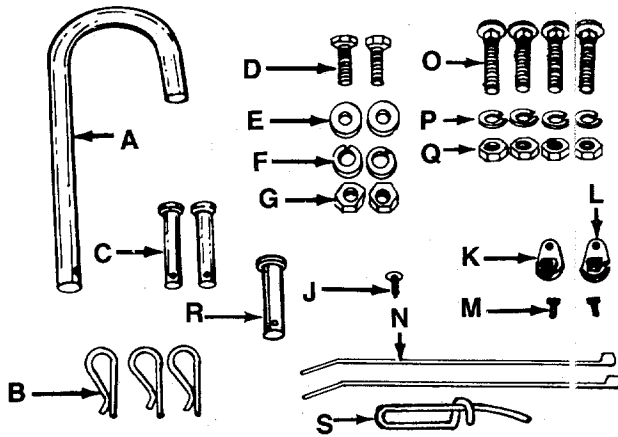

FIGURE 1.

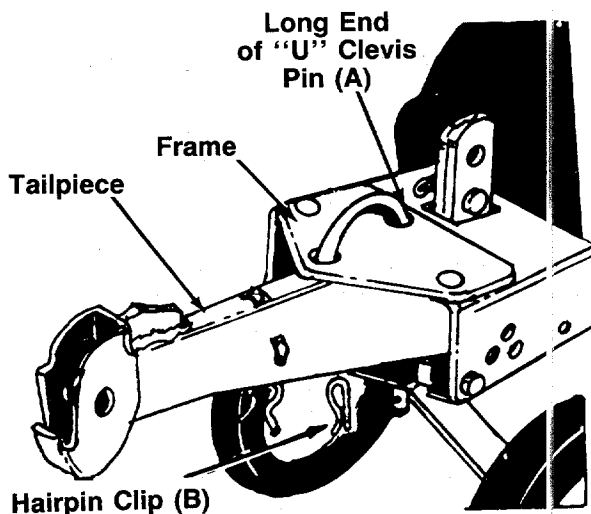

FIGURE 2.

TAILPIECE INSTALLATION

Slide the tailpiece into the chassis. Secure with "U"-clevis pin (A) and hairpin clip (B). See figure 2.

NOTE

The U-clevis pin which secures the tailpiece can be set for two different methods of operation. Refer to "Swinging Tailpiece/Depth Stake" section on page 10.

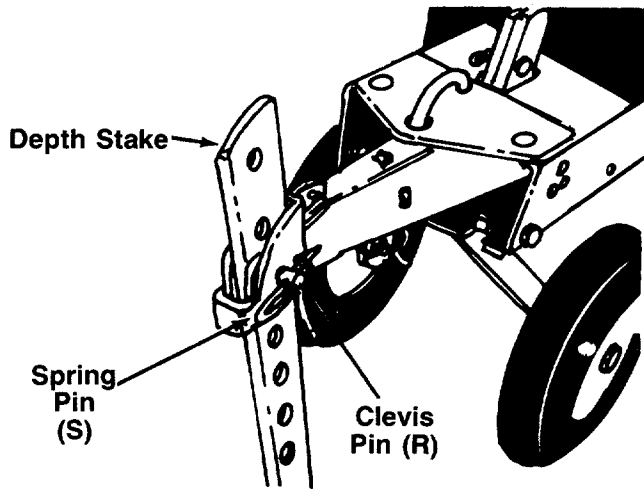

DEPTH STAKE INSTALLATION

Slide the depth stake into the tailpiece to desired depth. Pointed end of depth stake should face forward. Secure with clevis pin (R) and spring pin (S). See figure 3.

FIGURE 3.

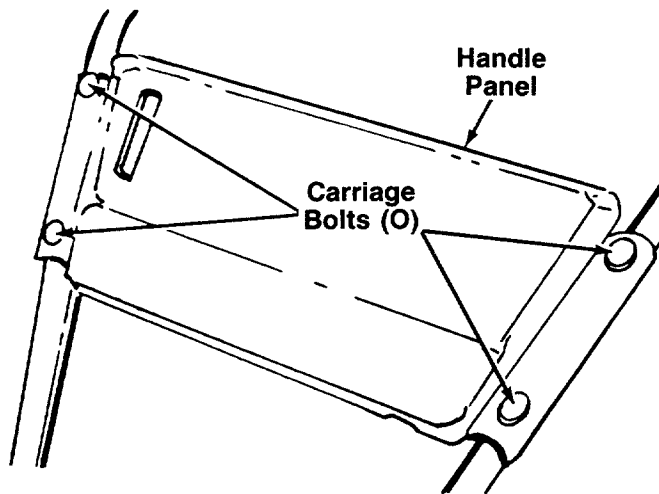

ASSEMBLY OF HANDLES

1. Place the handle panel in position on the right and left hand handles so the lower ends of the handles bend toward the inside.
2. Secure with carriage bolts (O), lock washers (P) and hex nuts (Q), finger tight only. See figure 4.
3. Remove hex bolt and belleville washer from each side of frame as shown in figure 5.

FIGURE 4.

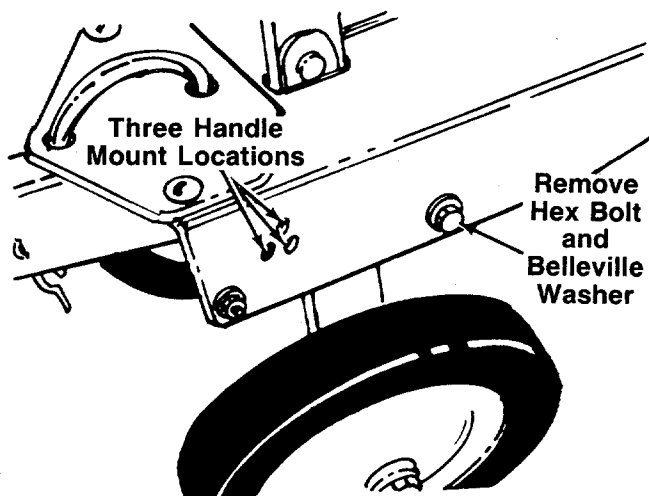

4. Place the handle panel assembly in position against the frame.
5. Start the hex bolt and belleville washer (removed in step 3) by hand in the bottom hole in handle.
6. Select height position for the handle by lining up one of the holes in the handle with desired hole in frame. See figure 5.

FIGURE 5.

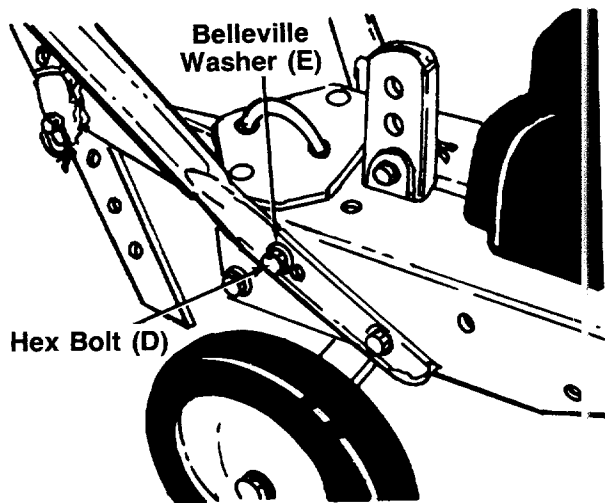

FIGURE 6.

7. Place belleville washer (E) on hex bolt (D), and insert hex bolt through handle and frame. Secure with lock washer (F) and hex nut (G) on inside of frame. See figure 6.
8. Tighten securely all nuts and bolts used to assemble the handle.

THROTTLE CONTROL ASSEMBLY

The throttle control is already attached to the engine. Assemble the throttle control to the handle panel as follows (be careful not to kink the cable).

1. Route the throttle control cable between the handle mounting brackets. Hold the throttle control assembly beneath the handle panel. Turn the control sideways and insert the lever up through the wide portion of the slot on the handle panel. See figure 7A.
2. After the end of the lever is through the slot, turn and then tip the control forward as shown in figure 7B.

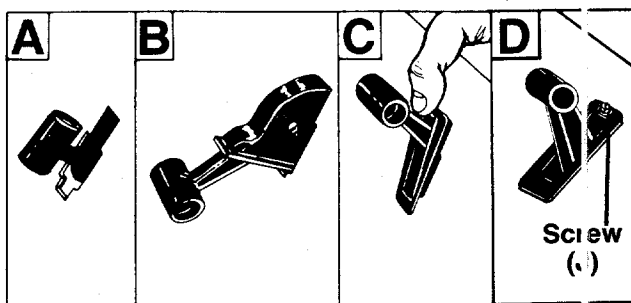

FIGURE 7.

NOTE

The lever must be all the way to the back of the control housing as shown in figure 7B.

3. Push the control back into the slot in the handle panel and press in place. See figure 7C. Be certain the control is locked securely into the slot.
4. Secure the throttle control to the handle panel using phillips head self-tapping screw (J). See figure 7D.

ATTACHING THE CLUTCH CONTROL CABLES

The clutch control cables, already attached to the idler brackets, are labeled FORWARD and REVERSE. The left hand cable hold-down is black and is marked with an "L." The right hand cable hold-down is brown and is marked with an "R."

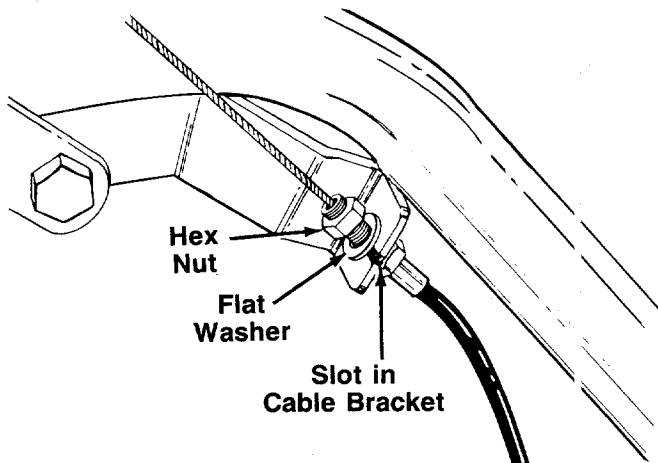

FIGURE 8.

1. Attach the forward clutch cable to the left handle as follows (be careful not to kink the cable).
 - a. Remove one hex nut and flat washer from the end of the casing on the forward clutch cable. Slip the wire through the slot on the cable bracket on the left handle. Push the end of the casing up through the cable bracket. Rethread the hex nut on the end of the cable. Do not tighten at this time. See figure 8.

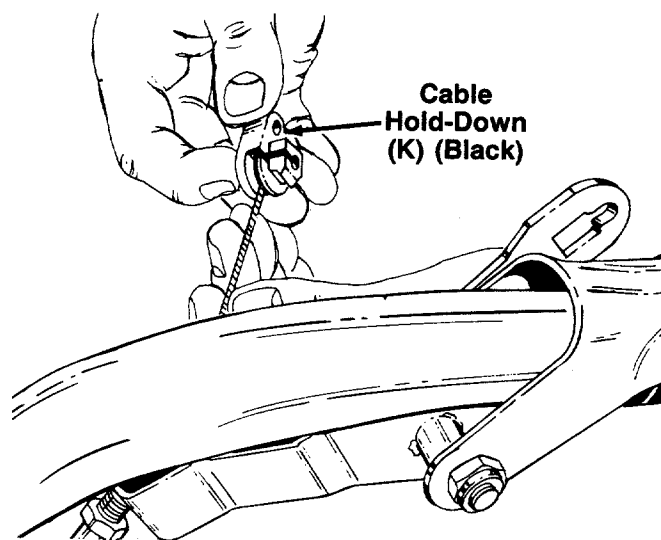

FIGURE 9.

- b. Hook the barrel end of the cable into the left hand cable hold-down (K) (black). Slide the cable around in the slot as shown in figure 9.

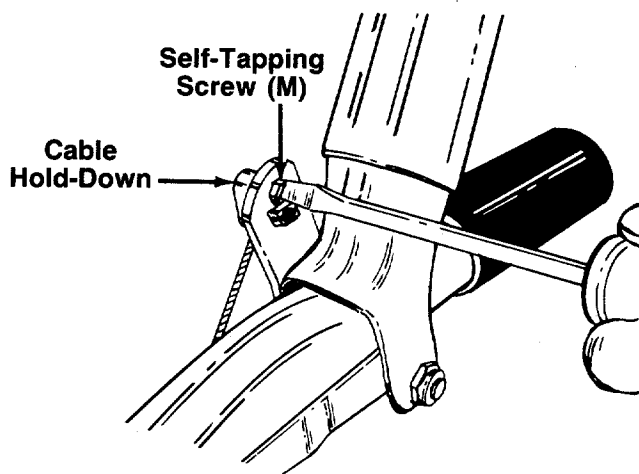

FIGURE 10.

- c. Pull the cable upwards to obtain slack, lift clutch grip, and insert the left hand cable hold-down into the left hand clutch grip. Secure with self-tapping screw (M). See figure 10.

- d. With the clutch lever released (in the "up" position), adjust the bottom nut at the cable bracket so there is only a slight amount of slack in the control wire. Tighten the upper nut against the bracket. Squeeze the clutch lever against the handle. The control wire should now be straight. See figure 11.

NOTE

Do not overtighten control wire. Too much tension may cause it to break.

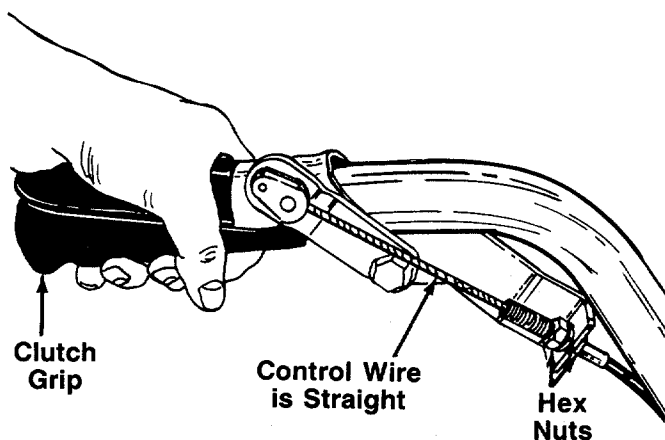

FIGURE 11.

2. Attach the reverse clutch cable to the right handle in the same manner, using the right hand cable hold-down (L) (brown).
3. Secure the control cables to the handles using cable ties (N).
4. Trim excess ends of cable ties.



WARNING

The forward and reverse clutch cable adjustment must be checked before the unit is operated as instructed in the Final Adjustment section on page 8.

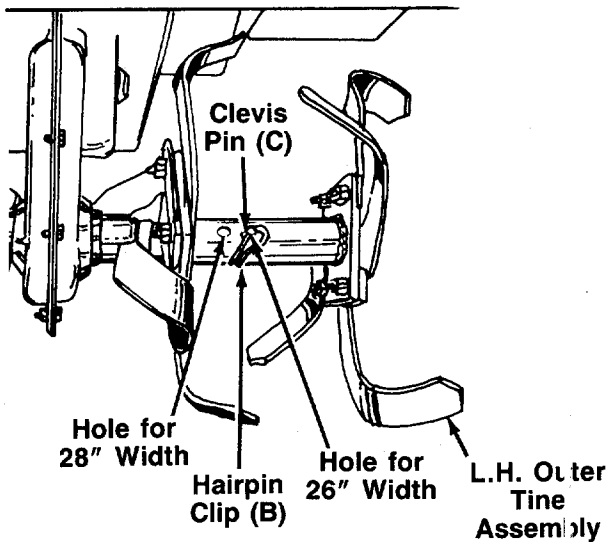

FIGURE 12.

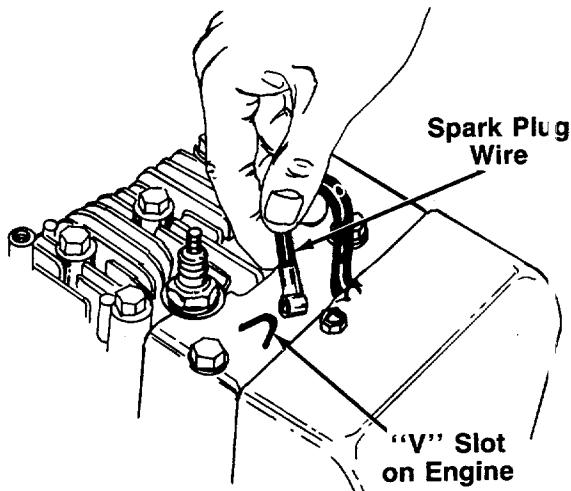

FIGURE 13.

CONTROLS

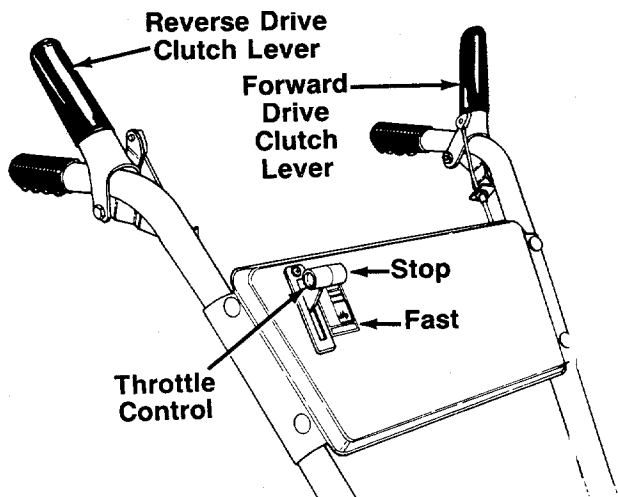

FIGURE 14.

TINE INSTALLATION

The inner tine assemblies are installed in their correct position at the factory. Check to be certain the tine assemblies are on the tine shaft so that the sharp edge enters the soil first. See figure 12.

1. Align one of the holes in the tine assembly with the hole in the tine shaft. Using the end hole on the tine assembly will give a tilling width of 28". Using the second hole will give a tilling width of 26". See figure 12.
2. Secure with clevis pin (C) and hairpin clip (B).
3. Secure the other tine assembly in the same manner.

NOTE

Make certain tines are installed so that the sharp edge of the tines will enter the soil first when in forward drive.

FINAL CLUTCH ADJUSTMENT

To check the forward and reverse clutch cable adjustment, proceed as follows.

1. Disconnect the spark plug wire from the spark plug to prevent accidental starting. Secure the end of spark plug wire in the "V" slot on the engine. See figure 13.
2. With both clutch grips released (neutral position), pull the starter rope several times. **The tines should not turn.** If they turn forward, loosen the hex nut below the cable bracket on the **left** handle a few turns. Tighten the hex nuts above the bracket. If they turn in reverse, adjust the hex nuts at the cable bracket on the **right** handle in the same manner.

THROTTLE CONTROL

The throttle control lever is located on the handle panel. It controls the engine speed and stops the engine. See figure 14.

FORWARD DRIVE CLUTCH LEVER

The forward drive clutch lever is located on the left handle. See figure 14. Squeezing the lever against the handle engages the forward tine drive. Release the lever to stop the forward motion.

REVERSE DRIVE CLUTCH LEVER

The reverse drive clutch lever is located on the right handle. See figure 14. Squeezing the lever against the handle moves the tines in reverse. Release the lever to stop the reverse drive.

NOTE

Never engage both the forward and reverse drive at the same time, or the engine will stall.

DEPTH STAKE

The depth stake controls the tilling depth. Refer to "How to Use Your Tiller" section on pages 9 and 10.

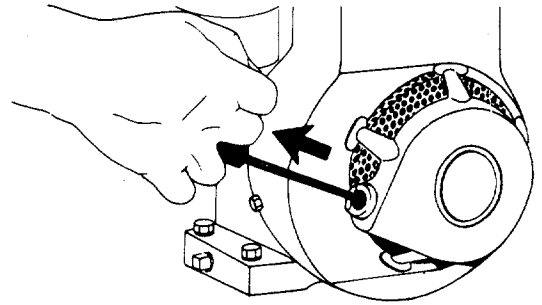

FIGURE 15.

OPERATION

GAS AND OIL FILL-UP

Service the engine with gasoline and oil as instructed in the separate engine manual packed with your tiller. **Read instructions carefully.**

NOTE

Your tiller is shipped without oil; however, a small amount of oil may be present from the factory.

TO START ENGINE



BE SURE NO ONE IS STANDING IN FRONT OF THE TILLER WHILE THE ENGINE IS RUNNING OR BEING STARTED.

1. Attach spark plug wire and cover to spark plug.
2. Make certain both clutch levers are in the neutral position (released). See figure 14.
3. Place the throttle control lever in FAST position. See figure 14.
4. Move choke lever to CHOKE position.

NOTE

A warm engine may not require choking.

5. Grasp starter handle (see figure 15) and pull rope out slowly until engine reaches start of compression cycle (rope will pull slightly harder at this point). Let the rope rewind slowly.
6. Pull rope with a rapid, continuous, full arm stroke. Keep a firm grip on start handle. Let rope rewind slowly. Do not let starter handle snap back against starter.
7. Repeat preceding instructions 5 and 6 until engine fires. When engine starts, move choke lever on engine halfway between CHOKE and RUN.

8. Move throttle control to SLOW position for a few minutes warm-up. Move choke lever to RUN position as engine warms up.

NOTE

In order to idle smoothly, a new engine may require 3 to 5 minutes running above slow idle speed. Idle speed has been adjusted to be correct after this break-in period.

TO STOP ENGINE

1. Move throttle control lever to STOP position. See figure 14.
2. Disconnect spark plug wire from spark plug and ground against the engine to prevent accidental starting while equipment is unattended.

HOW TO USE YOUR TILLER

The tiller is a precision built machine designed for seed bed preparation, cultivating, furrowing and mulching. It is engineered to minimize the hardest work in the vegetable or flower garden, to till the soil for planting and cultivating, and to perform many other useful labor saving tasks in the garden. With the proper amount of care and maintenance, this machine will provide the owner with many years of service.

WHEEL POSITION

The tiller is shipped with the wheels adjusted such that the unit sits level. During digging as the tines enter the ground and the front of the tiller lowers, the wheels must be raised to level the unit, which is essential for proper engine operation. This adjustment is made by removing the clevis pin and hairpin clip from wheel yoke, raising the wheels to the desired height, and replacing the clevis pin and hairpin clip. See figure 16.

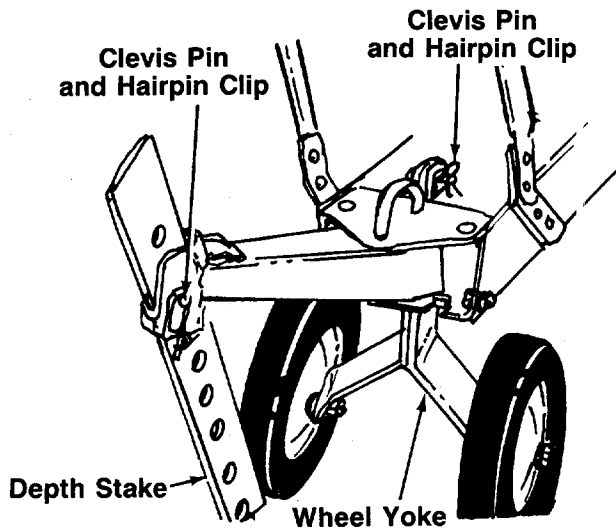

FIGURE 16.

SWINGING TAILPIECE/DEPTH STAKE

The entire tailpiece and depth stake can be either locked in position or allowed to swing freely. The tailpiece and depth stake are used in the unlocked position when it is necessary to maneuver in small areas. To lock, line up the holes in the rear frame with the holes in the tailpiece, and push in the short end of the U-clevis pin. To allow the tailpiece and depth stake to swing, pull out the U-clevis pin and place it in the forward hole as shown in figure 17.

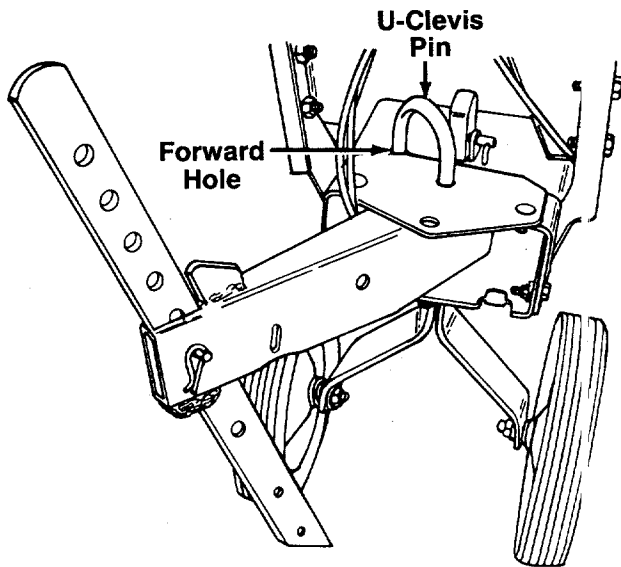

FIGURE 17.

CONTROLLING SPEED AND TILLING DEPTH:

1. **Wheel Yoke Adjustment:** Place wheel yoke so that the wheels are forward (nearest point between wheels and tines) for shallow tilling, cultivating and transport. The forward speed will increase. Turn yoke around (farthest point between wheels and tines) for deep tilling. Forward speed will decrease. See figures 16 and 18.

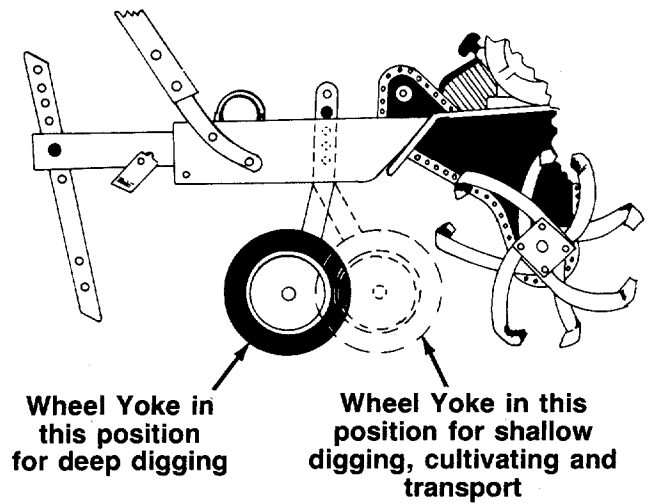

FIGURE 18.

2. **Depth Stake Adjustment:** The depth stake acts as a brake for the tiller and controls the depth and speed at which the machine will operate. Remove the clevis pin and hairpin clip to raise or lower depth stake. See figure 16.

By increasing the depth of the depth stake, the forward speed of the machine is reduced, and the working depth is increased. See figure 19. When the depth stake is raised, the working depth of the machine is reduced and the forward speed is increased. The working depth of the machine may be predetermined by setting the depth stake and wheels so that the wheels are about four inches from the ground when the tines and depth stake are resting on the ground. This setting will permit a working depth of about four inches. When presetting the working depth, the handles should be adjusted so the hand grips are a little above waist height because the tiller will be lower when the tines and depth stake penetrate the ground.

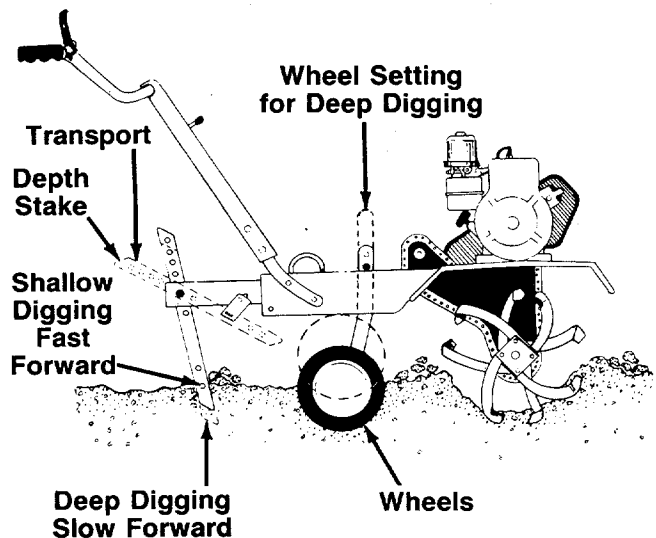

FIGURE 19.

When tilling, leave approximately 8 inches of untilled soil between the first and second tilling paths, then make the third path between the first and second as shown in figure 20. In some soils, the desired depth is obtained the first time over the garden. In other soils, the desired depth is obtained by going over the garden two or three times. In the latter case, the depth stake should be lowered before each succeeding pass over the garden. Passes should be made across the length and width of the garden alternately. Rocks which are turned up should be removed from the garden area.

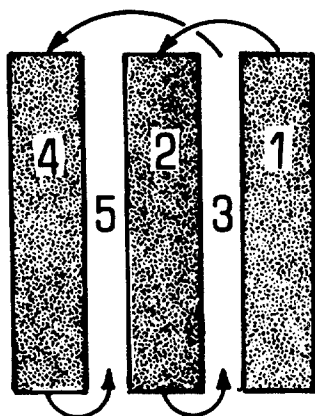

FIGURE 20.

3. **Handle Pressure:** Further control of tilling depth and travel speed can be obtained by variation of pressure on the handles. A downward pressure on the handles will reduce the working depth and increase the forward speed. An upward pressure on the handles will increase the working depth and reduce the forward speed. The type of soil and working conditions will determine the actual setting of the depth stake and the handle pressure required.
4. **Throttle Control:** The throttle control lever adjusts the engine speed and stops the engine. With the throttle control knob pushed completely forward, the carburetor is in START position. Pulling the throttle control back slightly adjusts the engine speed to FAST. Pulling the throttle back further reduces the engine speed to SLOW. Pull the throttle completely back to stop the engine.

Use maximum engine speed for deep tilling. Move the throttle control to SLOW when transporting the tiller.

TRANSPORTING THE TILLER

To transport the tiller to or from the garden, pivot the depth stake forward so it engages the tailpiece and locks out of the way. See figure 19. With the throttle control in SLOW position, the unit will move under its own power, without damaging grass areas as long as it is allowed to move freely. If the operator holds back, it will start to dig.

CULTIVATING

For cultivating, a two to three inch depth is desirable. Setting the wheels and depth stake so that the wheels are about two inches above the ground while the tiller is resting on the tines and depth stake will allow the machine to work at cultivating depth. The throttle should be set to control forward movement to a slow walking speed. With the outer tines installed, the working width of the machine is 26 or 28 inches. See figures 21 and 22. For cultivation, this may be reduced to 14 inches by removing the outer tines. See figure 22.

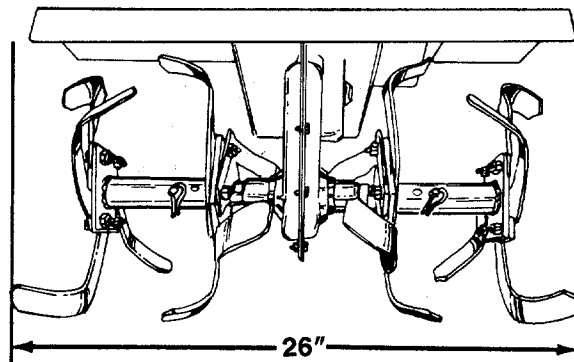

FIGURE 21.

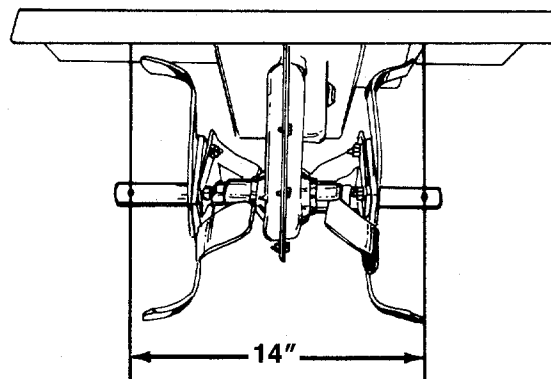

FIGURE 22.

Tilling width can be increased from 26 inches to 28 inches by removing the clevis pin and hairpin clip and sliding the outer tines out one inch, and replacing the clevis pin and hairpin clip. See figure 23.

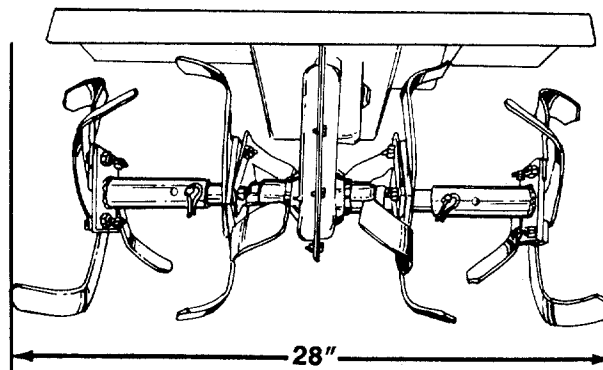

FIGURE 23.

When laying out plant rows, be sure to allow enough width to permit cultivation between the rows. In growing corn or similar crops, check-row planting will permit cross cultivation and practically eliminate hand hoeing. See figure 24.

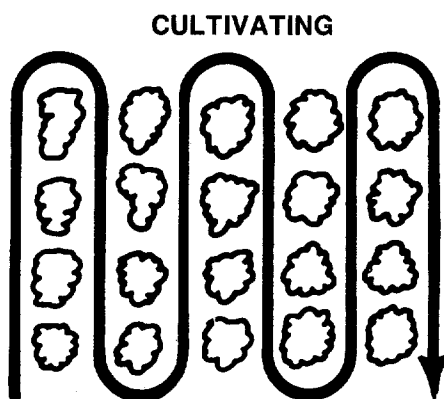

FIGURE 24.

The tiller has many uses other than tilling and cultivating a garden. One of these is the preparation of lawn area for seeding. The tiller will prepare a deep seed bed which will be free of hard untilled spots, allowing a better stand of grass to grow. The tiller is very useful for loosening hard soil for excavation with a shovel. NO tedious hand pickwork will be necessary. Your tiller may be used for mixing compost in the pile, or for mixing it with the soil in your garden. This should be done after the soil has been broken to the full working depth. The compost should be worked in to a depth of six to eight inches. This may be done by working the length of the garden, and then by making separate passes across its width. The addition of decayed organic matter will substantially increase the fertility of your garden. For proper decaying action, fertilizer should be applied and worked in with the mulch materials. Breaking up leaves and straw and mixing it with several inches of soil causes the soil to hold moisture longer and allows proper aeration of the plant root system. This also retards the growth of weeds.

The U.S. Department of Agriculture and various state and local agencies offer published booklets and expert advice on all phases of gardening. They should be consulted regarding soil information, planting dates, and the most satisfactory varieties of crop for your particular area.

ADJUSTMENTS



Disconnect the spark plug wire and ground against the engine before performing any adjustments, repairs, or maintenance.

WHEEL ADJUSTMENTS

To adjust the wheel yoke and wheel position, refer to "How To Use Your Tiller," on pages 9 and 10.

DEPTH STAKE ADJUSTMENT

To adjust the depth stake, refer to "How To Use Your Tiller" on pages 9 and 10.

TINE WIDTH ADJUSTMENT

To adjust the tine width, refer to "Cultivating" on page 11.

CLUTCH CONTROL ADJUSTMENTS

To adjust the clutch controls refer to the final adjustment section of assembly instructions.

CARBURETOR ADJUSTMENT



If any adjustments are made to the engine while the engine is running (e.g. carburetor), disengage all clutches and tines. Keep clear of all moving parts. Be careful of heated surfaces and muffler.

Minor carburetor adjustment may be required to compensate for differences in fuel, temperature, altitude or load. If adjustments are needed, refer to the engine manual packed with the tiller.

NOTE

A dirty air cleaner will cause engine to run rough. Be certain air cleaner is clean and attached to the carburetor before adjusting carburetor. Do not make unnecessary adjustments. Factory settings are satisfactory for most applications and conditions.

THROTTLE CONTROL ADJUSTMENT

To obtain satisfactory engine performance, the engine throttle control must be adjusted properly. If it is necessary to check the engine control adjustments, proceed as follows.

1. Loosen the cable clamp screw. See figure 25.
2. With the throttle control in FAST position (see figure 14) and the cable connected to the adaptor lever, push the cable through the cable clamp in the direction shown in figure 25 until the adaptor lever is as far up as it will go.
3. Tighten the cable clamp screw.
4. Check that the engine stops when throttle control is moved to STOP position. If engine does not stop, loosen cable clamp screw and readjust by pulling cable backward slightly until engine stops. Retighten cable clamp screw.

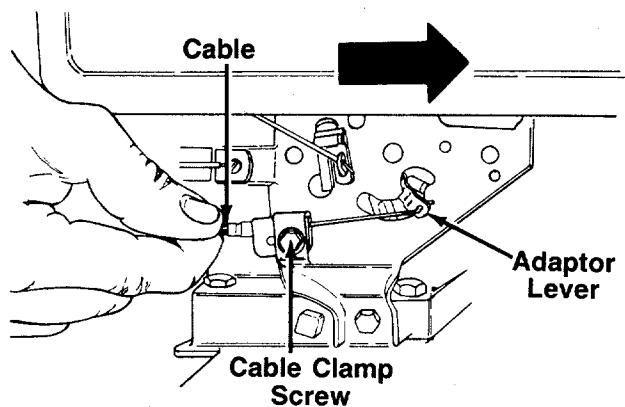

FIGURE 25.

LUBRICATION



WARNING

Always stop engine and disconnect spark plug wire before cleaning, lubricating or doing any kind of work on tiller.

Pivot Points—Remove the belt cover and lubricate all moving parts and pivot points at least once a season using SAE 30 engine oil.

Chain Drive—The chain case is pre-lubricated and sealed at the factory. It requires no checking unless the transmission is disassembled. To fill with grease, lay the left half of the chain case on its side, add 14 ounces of Plastilube #0 grease and assemble the right half to it. This grease can be obtained at your nearest authorized service dealer. Order part number 737-0133.

MAINTENANCE



WARNING

Disconnect spark plug wire and ground it against the engine before performing any repairs or maintenance.

TROUBLE SHOOTING

Refer to page 15 of this manual for trouble shooting information.

ENGINE

Refer to the separate engine manual for all engine maintenance instructions.

Maintain **engine oil** as instructed in the separate engine manual packed with your unit. Read and follow instructions carefully.

Service **air cleaner** every 25 hours under normal conditions. Clean every few hours under extremely dusty conditions. Poor engine performance and flooding usually indicates that the air cleaner should be serviced. To service the air cleaner, refer to the separate engine manual packed with your unit.

The **spark plug** should be cleaned and the gap reset once a season. Spark plug replacement is recommended at the start of each tilling season; check engine manual for correct plug type and gap specifications.

BELT REMOVAL AND REPLACEMENT

Your tiller has been engineered with belts made of special material (Kevlar Tensile). They should not be replaced with an off-the-shelf belt.

If belt replacement is required, order belt or belts by part number from your nearest authorized service dealer.

FORWARD DRIVE BELT— Part No. 754-0154
 REVERSE DRIVE BELT— Part No. 754-0201

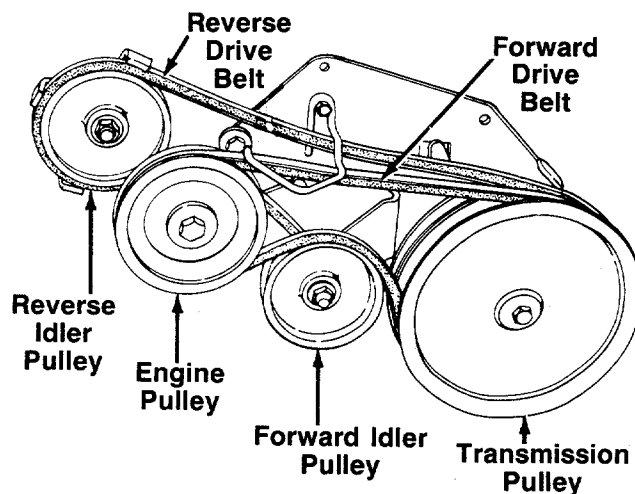

FIGURE 26.

Forward Drive Belt (Refer to figure 26)

1. Remove the belt guard, by removing four hex self-tapping screws.
2. Press down on the left side of the tine shield and slip off the belt guard. See figure 27.

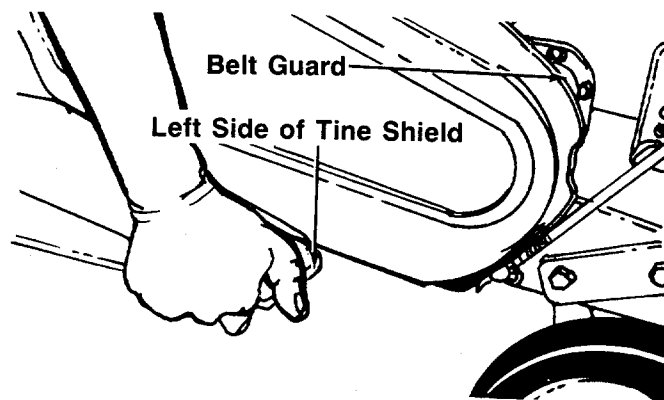

FIGURE 27.

3. Remove the forward drive belt from beneath the belt retainer. See figure 28.
4. Roll belt off the transmission pulley.
5. Remove the belt from around the engine pulley, and lift it off the idler pulley.

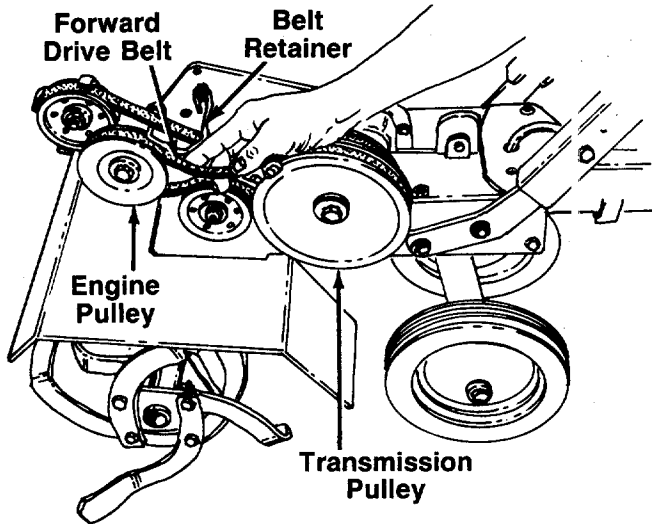

FIGURE 28.

6. Reassemble the new belt, following instructions in reverse order. Be certain to adjust the clutch control as instructed in the final clutch adjustment section of assembly instructions.

NOTE

Make certain the forward drive belt is assembled with the wide side of the belt away from the transmission and engine pulleys.

Reverse Drive Belt (Refer to figure 26)

1. To remove the reverse drive belt, first remove the forward drive belt as instructed in the previous section.
2. Remove the reverse drive belt from beneath the belt retainer.
3. Roll belt off the transmission pulley. Remove it from beneath the forward idler bracket. See figure 29.

Forward Idler Bracket

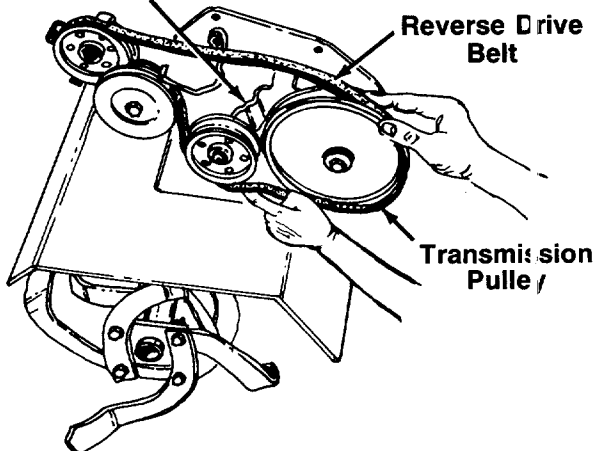

FIGURE 29.

4. Remove the hex nut which secures the reverse idler pulley to the idler bracket. See figure 3). Slide idler pulley out and remove the belt.

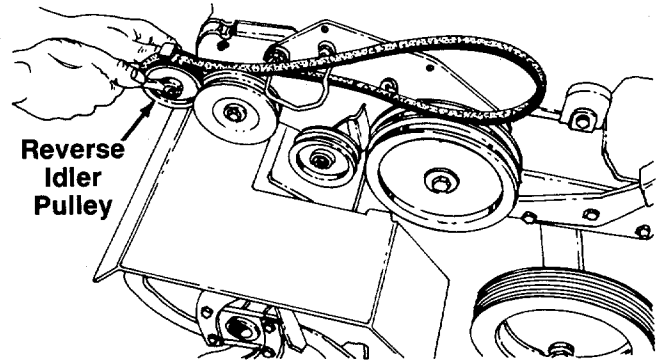

FIGURE 30.

5. Reassemble the new belt, following instructions in reverse order. Be certain to adjust the clutch control as instructed in the final clutch adjustment section of assembly instructions.

NOTE

Make certain the reverse drive belt is assembled with the wide side of the belt against the transmission and engine pulleys.

OFF-SEASON STORAGE

If the tiller is to be inoperative for a period longer than 30 days, the following precautions are recommended.

1. Working outdoors, drain all fuel from the fuel tank. Run the engine until it stops from lack of fuel.



WARNING

DO NOT DRAIN FUEL WHILE SMOKING, OR IF NEAR AN OPEN FIRE.

2. Drain all the oil from the crankcase (this should be done after the engine has been operated and is still warm) and refill the crankcase with fresh oil.
3. Protect the inside of the engine for storage as follows.

Remove spark plug, pour approximately 1/2 ounce (approximately one tablespoon) of engine oil into cylinder and crank slowly to distribute oil. Replace spark plug.

4. Clean the engine and the entire tiller thoroughly.
5. Wipe tines with oiled rag to prevent rust.

NOTE

When storing any type of power equipment in an unventilated or metal storage shed, care should be taken to rustproof the equipment. Using a light oil or silicone, coat the equipment, especially any springs, bearings and cables.

6. Store in a clean, dry area.

Trouble Shooting Guide

Trouble	Possible Cause(s)	Corrective Action
Engine fails to start	<ol style="list-style-type: none"> 1. Fuel tank empty, or stale fuel. 2. Throttle control lever not in starting position. 3. Blocked fuel line. 4. Spark plug wire disconnected. 5. Faulty spark plug. 6. Engine flooded. 	<ol style="list-style-type: none"> 1. Fill tank with clean, fresh gasoline. 2. Move throttle lever to start position. 3. Clean fuel line. 4. Connect wire to spark plug. 5. Clean, adjust gap or replace. 6. Remove spark plug, dry the plug, and crank engine with plug removed and throttle in off position. Replace spark plug, connect wire and resume starting procedures.
Engine runs erratic	<ol style="list-style-type: none"> 1. Unit running on CHOKE. 2. Spark plug wire loose. 3. Blocked fuel line or stale fuel. 4. Vent in gas cap plugged. 5. Water or dirt in fuel system. 6. Dirty air cleaner. 7. Carburetor out of adjustment. 	<ol style="list-style-type: none"> 1. Move choke lever to OFF position. 2. Connect and tighten spark plug wire. 3. Clean fuel line; fill tank with clean, fresh gasoline. 4. Clear vent. 5. Drain fuel tank. Refill with fresh fuel. 6. Clean air cleaner as instructed in separate engine manual. 7. Adjust carburetor as instructed in separate engine manual.
Engine overheats	<ol style="list-style-type: none"> 1. Engine oil level low. 2. Air flow restricted. 3. Carburetor not adjusted properly. 	<ol style="list-style-type: none"> 1. Fill crankcase with proper oil. 2. Remove blower housing and clean as instructed in separate engine manual. 3. Adjust carburetor as instructed in separate engine manual.
Tines do not engage	<ol style="list-style-type: none"> 1. Foreign object lodged in tines. 2. Tine clevis pin(s) missing. 3. Control cable not adjusted properly. 4. Belt worn and/or stretched. 	<ol style="list-style-type: none"> 1. Dislodge foreign object. 2. Replace tine clevis pin(s). 3. Adjust control cable (see assembly instructions). 4. Replace belt.

NOTE: For repairs beyond the minor adjustments listed above, please contact your local service dealer.

Model 381

NOTE
Specifications subject to change without notice or obligation.

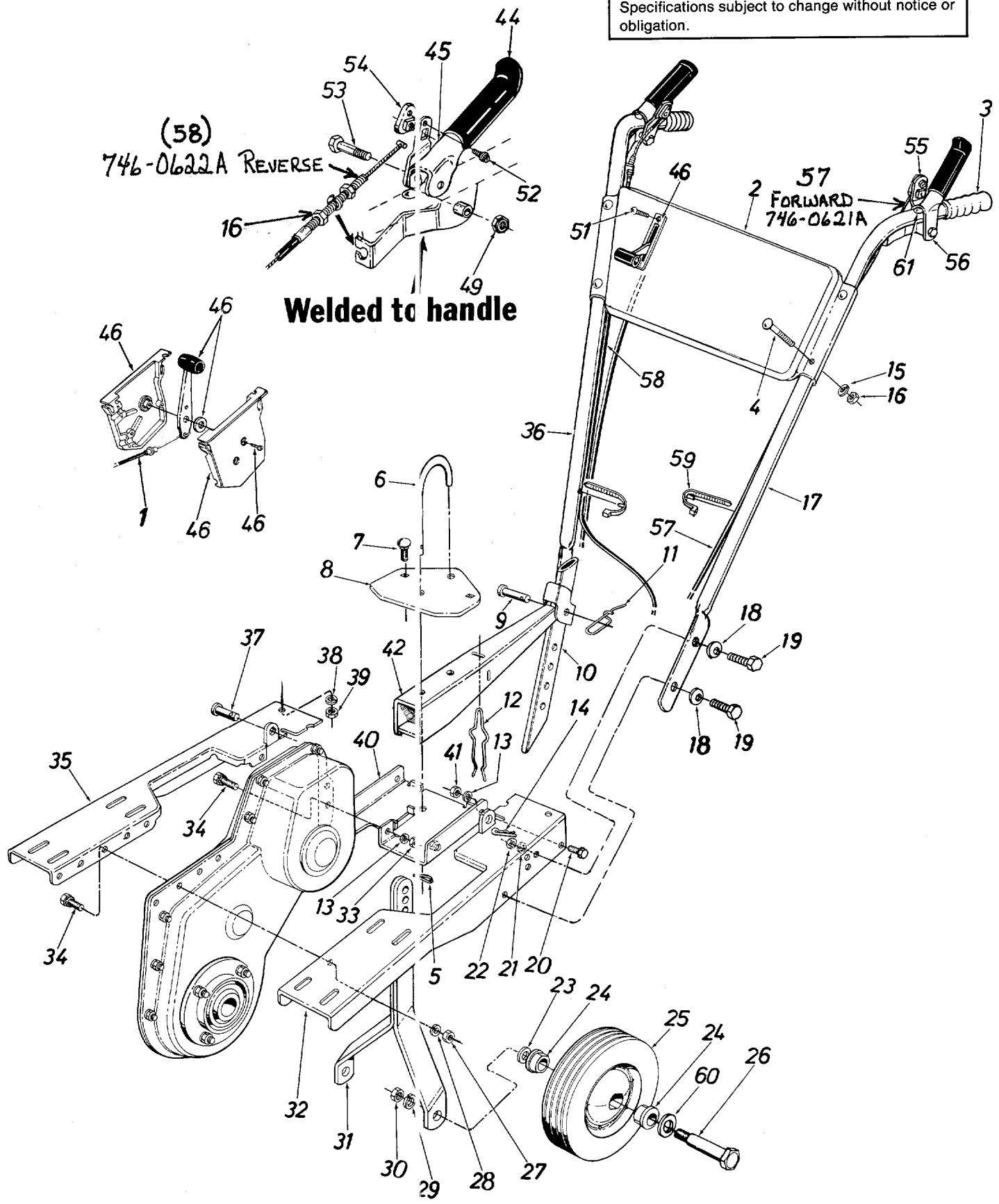

Model 381

PARTS LIST FOR MODEL 381 TILLER

REF. NO.	PART NO.	CODE	DESCRIPTION	REF. NO.	PART NO.	CODE	DESCRIPTION
1	746-0503		Throttle Control Wire—35" BLUE	30	712-0200A	N	Hex Ins. L-Nut 1/2-20 Thd.
2	784-0036A	638/N	Handle Panel Ass'y.	31	06813	638	Wheel Bracket Ass'y.
3	720-0180		Handle Grip	32	06792		Engine "U"-Channel
4	710-0458		Carriage Bolt 5/16-18 x 1.75"				Ass'y.—L.H.
5	714-0149B	N	Internal Cotter Pin	33	712-0267		Hex Nut 5/16-18 Thd.*
6	04602		"U"-Clevis Pin .500" Dia.	34	710-0322		Hex Sems Bolt 5/16-18 x
7	710-0451		Carriage Bolt 5/16-18 x .75"				1.00" Lg.*
8	04586		"U"-Channel Plate	35	06794		Engine "U"-Channel
9	711-0231		Clevis Pin 1/2" Dia.				Ass'y.—R.H.
10	04668	638	Depth Bar	36	784-0258		Handle—R.H.
11	732-0194		Spring Pin	37	1545-029		Clevis Pin .375" Dia.
12	732-0290		Depth Bar Spring	38	736-0119		L-Wash. 5/16" I.D.*
13	736-0119		L-Wash. 5/16" I.D.*	39	712-0267		Hex Nut 5/16-18 Thd.*
14	714-0149B	N	Internal Cotter Pin	40	06816		"U"-Channel Bracket Ass'y.
15	736-0119		L-Wash. 5/16" I.D.*	41	712-0267		Hex Nut 5/16-18 Thd.*
16	712-0267		Hex Nut 5/16-18 Thd.*	42	04589		Tailpiece Ass'y.
17	784-0259		Handle—L.H.	44	731-0869		Clutch Vinyl Grip
18	736-0105		Belleville Wash. 3/8" I.D.	45	784-0255		Clutch Grip Ass'y.—R.H.
19	710-0253		Hex Bolt 3/8-16 x 1.00" Lg.*	46	831-0823A	N	Throttle Control Box Ass'y.
20	710-0118		Hex Bolt 5/16-18 x .75" Lg.*	49	712-0116		Hex Ins. L-Nut 3/8-24 Thd.
21	736-0169		L-Wash. 3/8" I.D.*	51	710-0779A	N	Self-Tap Scr. #10 x 1/2" Lg.
22	712-0798		Hex Nut 3/8-16 Thd.*	52	710-0919		Self-Tap Scr. #10 x .44" Lg.
23	736-0253		Belleville Wash. .505 I.D. x	53	710-0151		Hex Bolt 3/8-24 x 2.0" Lg.
			1.00" O.D.	54	746-0606		Barrel Cable Hold-Down—R.H.
24	741-0116		Fl. Bearing w/Flats .631 I.D.	55	746-0605		Barrel Cable Hold-Down—L.H.
25	734-0584		Wheel Ass'y. Comp. 10 x 1.75	56	784-0202		Clutch Grip Ass'y.—L.H.
26	738-0318		Shoulder Bolt .625" Dia. x	57	746-0621A	N	Control Cable (Forward)
			2.75" Lg.	58	746-0622A	N	Control Cable (Reverse)
27	712-0267		Hex Nut 5/16-18 Thd.*	59	725-0157		Cable Tie
28	736-0119		L-Wash. 5/16" I.D.*	60	736-0187		Fl-Wash. .640 I.D. x 1.24"
29	736-0921		L-Wash. 1/2" I.D.*	61	726-0247		Plug

*For faster service obtain standard nuts, bolts and washers locally. If these items cannot be obtained locally, order by part number and size as shown on parts list.

CODE: N notates a new part (not previously existing). A three digit number is the **color code** (use if color or finish is important when ordering parts). See chart below. [i.e., (part no.)-638 for Red Finish].

Color Codes

460—Green Flake	630—Blue
483—Charcoal Grey	635—Grey
498—Yellow	636—White
499—Beige	637—Black
606—Orange	638—Red
629—Silver Flake	640—Green

Model 381

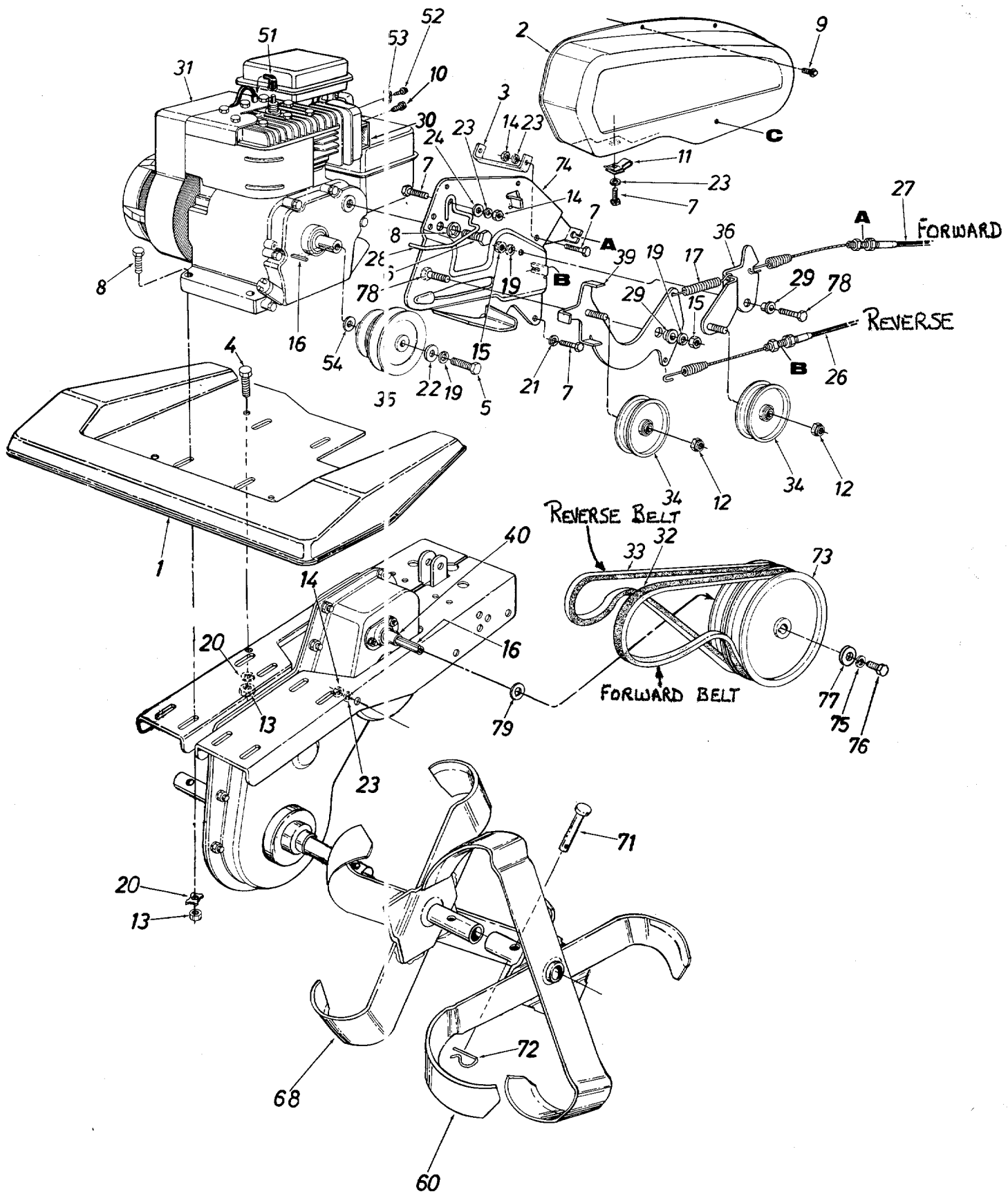

Model 381

PARTS LIST FOR MODEL 381 TILLER

REF. NO.	PART NO.	CODE	DESCRIPTION	REF. NO.	PART NO.	CODE	DESCRIPTION
1	04598	638	Tine Shield	29	738-0372		Shid. Spacer .380 I.D.
2	06796		Belt Guard	30	751-0233		Muffler Deflector
3	06801		Support Brkt.	31	—		Engine
4	710-0118		Hex Bolt 5/16-18 x .75" Lg.*	32	754-0154		V-Belt FORWARD 1/2" X 37"
5	710-0191		Hex Bolt 3/8-24 x 1.25" Lg.*	33	754-0201		V-Belt REVERSE 1/2" X 41"
6	710-0237		Hex Bolt 5/16-24 x .62" Lg.*	34	756-0225		FI-Idler w/Flanges 3.12 O.D.
7	710-0252		Hex Bolt 1/4-20 x .85" Lg.*				x .75
8	710-0442		Hex Bolt 5/16-18 x 1.5" Lg.*	35	756-0261		Engine Pulley
9	710-0599		Hex Wash. Hd. Tap Scr. 1/4-20 x .5" Lg.	36	784-0267		Idler Brkt. Ass'y.
10	710-0783		Hex Wash. Hd. Slotted Scr. #8-32 x .38"	39	784-0251		Reverse Idler Brkt. Ass'y.
11	712-0185		Speed Nut 1/4-20 Thd.	40	750-0229		Spacer .635 I.D.
12	712-0262		Hex L-Nut 3/8-24 Thd.	51	735-0639		Spark Plug Boot (Optional)
13	712-0267		Hex Nut 5/16-18 Thd.*	52	710-0899		Hex Sems Scr. #10-32 x .62"
14	712-0287		Hex Nut 1/4-20 Thd.*	53	751-0360A	N	Casing Clamp
15	712-0375		Hex L-Nut 3/8-16 Thd.	54	736-0315		FI-Wash. .75" I.D. x 1.5"
16	714-0133		Sq. Key 3/16 x 1.5" Lg.	60	784-0093		O.D. x .12"
17	732-0209		Extension Spring 2.03 Lg.				Outer Tine Ass'y. Comp.—
18	736-0119		L-Wash. 5/16" I.D.*		784-0094		L.H.
19	736-0169		L-Wash. 3/8" I.D.*				Outer Tine Ass'y. Comp.—
20	736-0170		Spec. L-Wash. 5/16" I.D.	68	784-0091		R.H. (Not Shown)
21	736-0175		Spr. Wash. .265" I.D. x .562" O.D.		784-0092		Inner Tine Ass'y.—L.H.
22	736-0258		FI-Wash. 3/8" I.D. x 1" O.D. x 1.27"	71	1545-029		Inner Tine Ass'y.—
23	736-0329		L-Wash. 1/4" I.D.*	72	714-0149B	N	R.H. (Not Shown)
24	736-0463		FI-Wash. .25 I.D. x .62 O.D.	73	756-0262		Clevis Pin
25	710-0152		Hex Bolt 3/8-24 x 1" Lg. (Grade 5)	74	784-0269		Intern. Cotter Pin
26	746-0622A	N	Clutch Control Cable (Reverse)	75	736-0119		Transmission Pulley 6" Dia.
27	746-0621A	N	Clutch Control Cable (Forward)	76	710-0643		Clutch Mtg. Plate
28	747-0181		Belt Guard Rod	77	736-0231		L-Wash. 5/16" I.D.*
				78	710-0152		Patch Bolt 5/16-18 x 1" Lg.
				79	736-0187		FI-Wash. 5/16" I.D.
							Hex Bolt 3/8-24 x 1.0" Lg. (Grade 5)
							FI-Wash. .635" I.D. x 1.25" O.D.

*For faster service obtain standard nuts, bolts and washers locally.
If these items cannot be obtained locally, order by part number and size as shown on parts list.

The engine is not under warranty by the tiller manufacturer. If repairs or service is needed on the engine, please contact your nearest authorized engine service outlet. Check the "Yellow Pages" of your telephone book under "Engines—Gasoline."



Model 381

Chain Case Assembly 801-5282

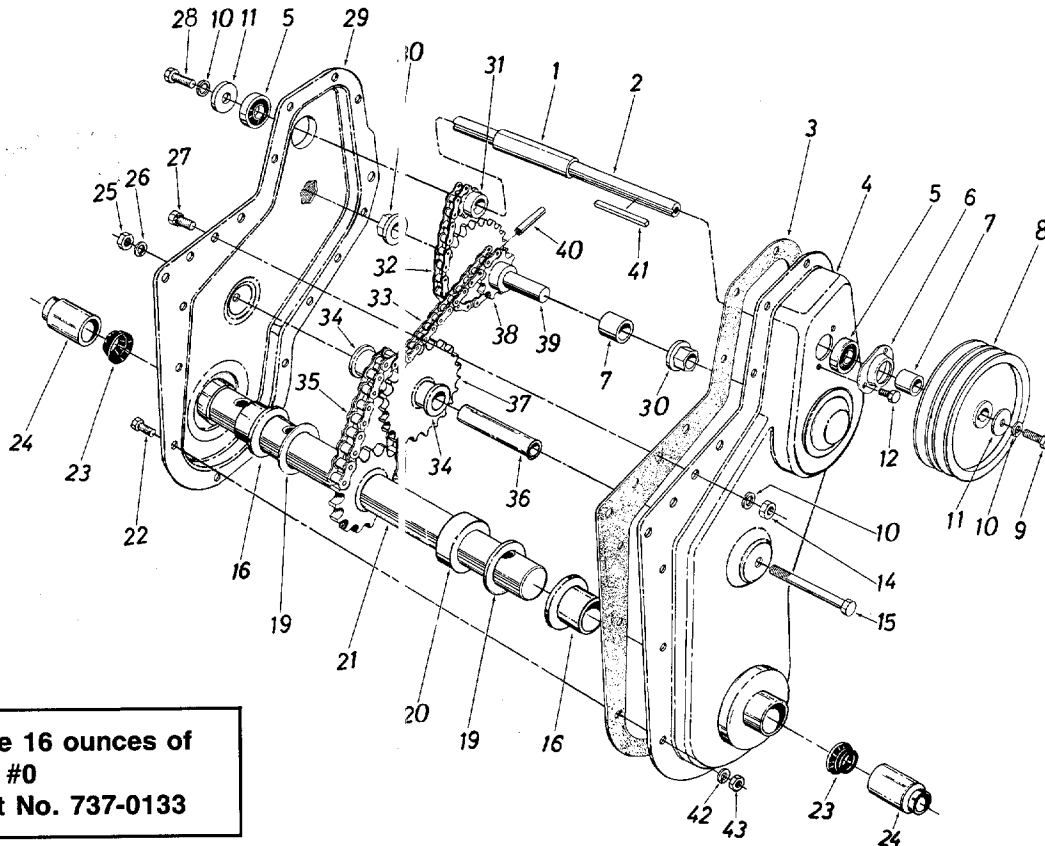

**NOTE: Use 16 ounces of Plastilube #0
Order Part No. 737-0133**

PARTS LIST FOR CHAIN CASE 801-5282

REF. NO.	PART NO.	CODE	DESCRIPTION	REF. NO.	PART NO.	CODE	DESCRIPTION
1	750-0315		Spacer .657 I.D. x .78 O.D. x 2.19" Lg.	25	712-0798		Hex Nut 3/8-16 Thd.*
2	738-0182		Jackshaft	26	736-0169		L-Wash. 3/8" I.D.*
3	721-0132		Housing Gasket	27	710-0322		Hex Sems Bolt 5/16-18 x 1.00" Lg.*
4	15276		Housing Ass'y.—L.H. Half	28	710-0538		Hex Bolt 5/16-18 x .62" Lg. (Special)
5	741-0155		Ball Bearing .625 I.D. x 1.375 O.D.	29	15274		Housing Ass'y.—R.H. Half
6	05034		Bearing Housing	30	748-0229		Hex Flanged Bearing
7	750-0229		Spacer .635 I.D. x .88 O.D. x 1.03" Lg.	31	713-0206		Sprocket 10 Teeth 1/2" Pitch
8	756-0262		Chain Case Pulley 6.0" Dia.	32	713-0131		#41 Chain 1/2" Pitch x 34 Links
9	710-0643		Hex Bolt 5/16-18 x 1.0" Lg. (Special)	33	713-0186		#420 Chain 1/2" Pitch x 48 Links
10	736-0119		L-Wash. 5/16" I.D.*	34	748-0855		Flange Bearing .625" I.D.
11	736-0231		Fl-Wash. .344" I.D. x 1.125" O.D.	35	713-0187		#50 Chain 5/8" Pitch x 28 Links
12	710-0599		Hex Wash. Hd. Self-Tap Scr. 1/4-20 x .50" Lg.	36	738-0320		Sprocket Shaft
14	712-0267		Hex Nut 5/16-18 Thd.*	37	713-0182		Sprocket Bearing Sleeve Ass'y.
15	710-0644		Hex Bolt 3/8-16 x 3.25" Lg.*	38	713-0181		Sprocket Sleeve Ass'y.
16	731-0374		Flange Bearing (Plastic)	39	738-0308		Sprocket Shaft
19	736-0163		Flat Thrust Wash.	40	715-0114		Spring Pin Spiral 1/4" Dia. x 1.5" Lg.
20	750-0314		Step Spacer	41	714-0133		Square Key 3/16 x 3/16 x 1.50" Lg.*
21	784-0090		Tine Shaft Ass'y.	42	736-0329		L-Wash. 1/4" I.D.*
22	710-0195		Hex Bolt 1/4-28 x .62" Lg.	43	712-0138		Hex Nut 1/4-28 Thd.*
23	721-0175		Seal Ring				
24	731-0487		Dust Cap				

Heavy Duty Garden Tiller Attachments Available for All-Season Use

31-0106	Depth Gauge Wheels (Pair)	31-0123	Lawn Aerator (Use with 31-0114 Wheel Weights for added penetration)
31-0107	6-Tine Cultivator (Must be used with 31-0106 Depth Gauge Wheels)	31-0144	"V"-Bar Cultivating Kit Kit Includes: "V"-Bar Frame, 4-Point Cultivating Tines, Hiller/Furrower, Depth Gauge Wheels (Pair).
31-0110	8" Furrower Opener	31-0145	Depth Stake Cultivating Kit Kit Includes: 8" Furrower Opener, 15" Sweep Cultivator, 32" Leveling Rake, Extra Depth Stake.
31-0111	15" Sweep Cultivator		
31-0113	Pneumatic Tires, 13 x 5.00-6 (Pair)		
31-0114	Wheel Weights (Pair)		
31-0115	Tire Chains, 13 x 5.00 (2 Link) (Pair)		
31-0119	Tine Cultivating Shields w/Adapters (Pair)		

Note: Attachments are available through your local dealer or from the factory:
Agri-Fab Inc., 303 W. Raymond Street, Sullivan, Illinois 61951 (217) 728-4334

PARTS INFORMATION

POWER EQUIPMENT PARTS AND SERVICE

Parts and service are available through the authorized service firms listed below. All orders should specify the model number of your unit, part numbers, description of parts and the quantity of each part required.

NOTE: If any parts are found to be missing or defective upon assembly of this unit, write to advise the factory so that immediate replacement can be made.

ALABAMA	BIRMINGHAM	NEW YORK	CARTHAGE
Auto Electric & Carburetor Co.	2625 4th Ave. S. Box 2466	Gamble Dist., Inc.	West End Ave. Box 389
	35233		13619
ARKANSAS	NORTH LITTLE ROCK	NORTH CAROLINA	GREENSBORO
Sutton's Lawn Mower Shop	5301 Roundtop Drive Box 368, Rt. 4	Dixie Sales Company	335 N. Green Box 1408
	72117		27402
CALIFORNIA	PORTERVILLE	OHIO	CARROLL
Billious	75 North D Street	Stebe's Mid-State Mower Supply	Box 366, 71 High St.
	93257		43112
COLORADO	DENVER	Bleckrie, Inc.	CLEVELAND
Spitzer Industrial Products Co.	6601 N. Washington St.		7900 Lorain Ave.
	80229		44102
FLORIDA	JACKSONVILLE	National Central	WADSWORTH
Radco Distributors	4909 Victor St. Box 5459		687 Seville Rd.
	32207	Burton Supply Co.	YOUNGSTOWN
Small Eng. Dist.	HIALEAH		1301 Logan Ave. Box 929
	7995 W. 26th Court		44501
	33016	PENNSYLVANIA	HARRISBURG
GEORGIA	EAST POINT	EECO Inc.	4021 N. 6th St.
East Point Cycle & Key Inc.	2834 Church St.		17110
	30344	Thompson Rubber Co.	WILLOW GROVE
ILLINOIS	LYONS		850 Davisville Rd.
Keen Edge Co.	8615 Ogden Ave.		19090
	60534	Bluemont Co.	PITTSBURGH
INDIANA	ELKHART		11101 Frankstown Rd.
Parts & Sales Inc.	2101 Industrial Pkwy. Box 277		15235
	46516	Frank Roberts & Sons	PUNXSUTAWNEY
IOWA	DUBUQUE		R.D. 2
Power Lawn & Garden Equip.	2551 J.F. Kennedy		15767
	52001	Scranton Auto Ignition Co.	SCRANTON
LOUISIANA	LAFAYETTE		1133-35 Wyoming Ave.
Jourdan Engine Co.	214 W. Vermillion St. Box 3503		1850
	70501	TENNESSEE	KNOXVILLE
MARYLAND	TAKOMA PARK	Ace Distributors	2103 Magnolia
Center Supply Co.	6867 New Hampshire Ave.		37917
	20912	American Sales & Service, Inc.	MEMPHIS
MASSACHUSETTS	SPRINGFIELD		3035-43 Bellbrook
Morton B. Collins Co.	300 Birnie Ave.		38116
	01107	TEXAS	DALLAS
MICHIGAN	MOUNT CLEMENS	Marr Brothers, Inc.	423 E. Jefferson
Power Equipment Dist.	340 Hubbard		75203
	48043	Engine House Inc.	SAN ANTONIO
MINNESOTA	PLYMOUTH		4918 Golden Quail
Hance Distributing Inc.	12795 16th Ave. North		78249
	55441	UTAH	SALT LAKE CITY
MISSOURI	EARTH CITY	Powered Products	1661 N. Beck St.
Oscar Wilson Engine & Parts	4159 Shoreline Dr.		84116
	63045	VIRGINIA	ASHLAND
Automotive Equip. Service	KANSAS CITY	RBI Corp.	101 Cedar Ridge Dr.
	3117 Holmes St.		23005
	64109	WASHINGTON	SEATTLE
NEW JERSEY	ALLOWAY	Equip. Northwest	1410 14th Ave.
Piersons	Canal St., Box 494		98122
	08001	WISCONSIN	MILWAUKEE
		Wisconsin Magneto Inc.	4727 N. Teutonia St.
			53209
		PUERTO RICO	AGUADILLA
		CIE & Associates, Inc.	Box 427 Ramey Station
			00604

WARRANTY PARTS AND SERVICE POLICY

(0588)

The purpose of warranty is to protect the customer from defects in workmanship and materials, defects which are NOT detected at the time of manufacture. It does not provide for the unlimited and unrestricted replacement of parts. Use and maintenance are the responsibility of the customer. The manufacturer cannot assume responsibility for conditions over which it has no control. Simply put, if it's the manufacturer's fault, it's the manufacturer's responsibility; if it's the customer's fault, it's the customer's responsibility.

CLAIMS AGAINST THE MANUFACTURER'S WARRANTY INCLUDES:

1. Replacement of Missing Parts on new equipment.
2. Replacement of Defective Parts within the warranty period.
3. Repair of Defects within the warranty period.

All claims MUST be substantiated with the following information:

1. Model Number, Serial Number and/or Data Code of unit involved.
2. Date unit was purchased or first put into service.
3. Date of Failure.
4. Nature of Failure.

MTD PRODUCTS INC • P.O BOX 360900 • CLEVELAND, OHIO 44136

Free Manuals Download Website

<http://myh66.com>

<http://usermanuals.us>

<http://www.somanuals.com>

<http://www.4manuals.cc>

<http://www.manual-lib.com>

<http://www.404manual.com>

<http://www.luxmanual.com>

<http://aubethermostatmanual.com>

Golf course search by state

<http://golfingnear.com>

Email search by domain

<http://emailbydomain.com>

Auto manuals search

<http://auto.somanuals.com>

TV manuals search

<http://tv.somanuals.com>