

Moxa EtherDevice Switch

EDS-728/828 Hardware Installation Guide

First Edition, January 2008



Moxa Inc.

Tel: +886-2-8919-1230

Fax: +886-2-8919-1231

www.moxa.com

Moxa Technical support.

Worldwide: support@moxa.com

The Americas: support@usa.moxa.com

P/N: 1802008280010

Panel Layout of EDS-728/828 Series

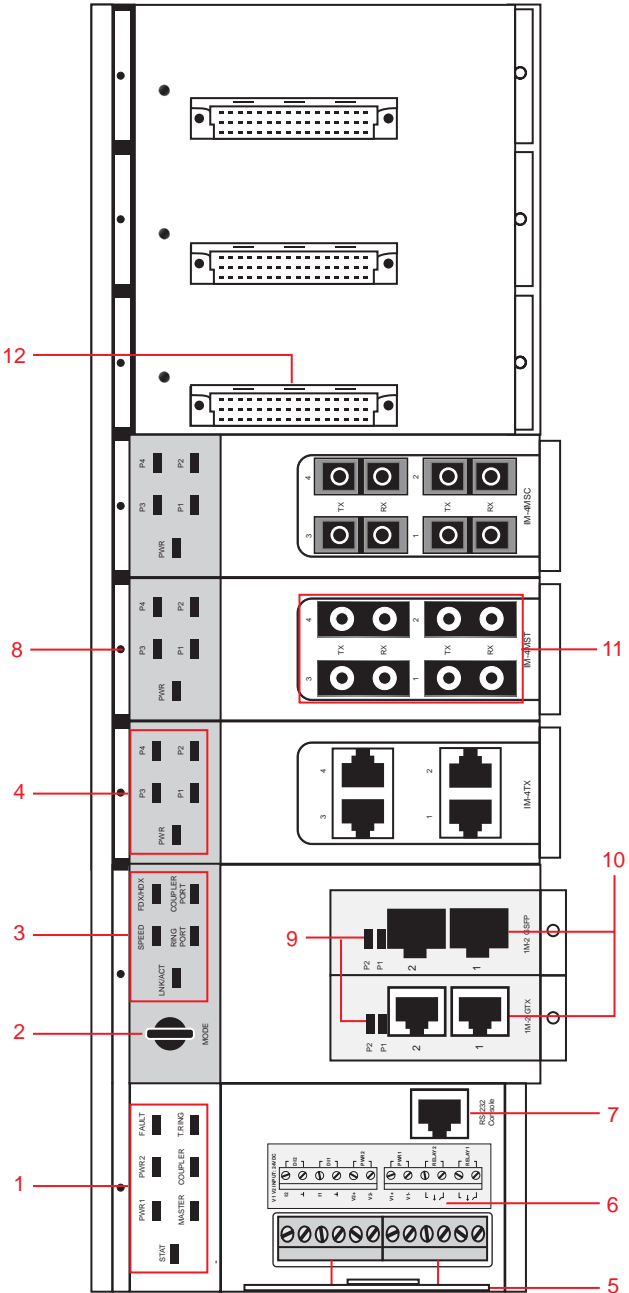

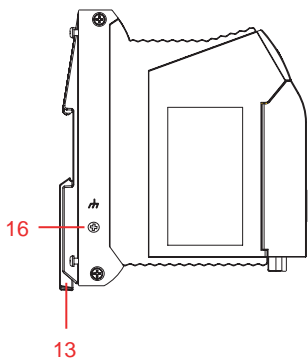
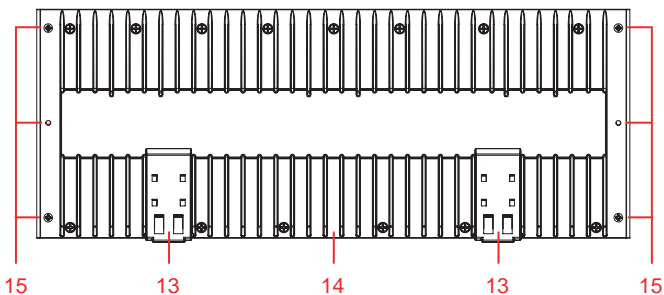

1. System status LEDs
2. Push-button switch to select mode for Interface Module
3. Interface Module mode LEDs
4. Fast Ethernet Interface Module port LEDs
5. Terminal block for 2 power inputs, 2 DIs, and 2 DOs
6. Sticker showing pin contacts
7. Serial console port
8. Screw to attach Fast Ethernet Interface Module
9. Gigabit Ethernet Module LEDs
10. Two cartridge receptors for Gigabit Ethernet Interface Modules
11. Fast Ethernet Interface Modules
12. Sockets for Fast Ethernet Interface Modules
13. DIN-Rail braces
14. Ribs for radiating heat
15. Screw holes for wall mounting kit
16. Grounding screw

Mounting Dimensions (unit = mm)



Front View

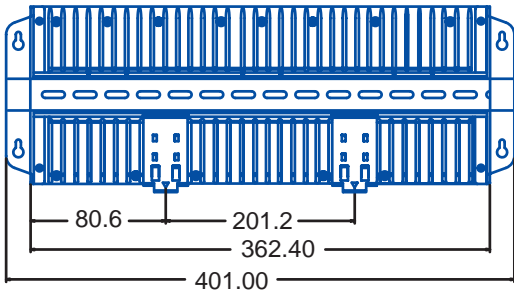

Rear View

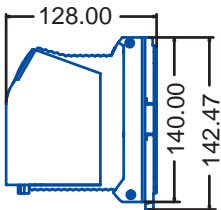

Side View

Fast Ethernet Interface Modules



Front View

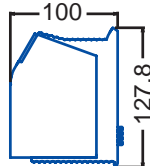

Side View

Gigabit Ethernet Interface Modules



Front View

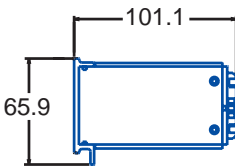

Side View

DIN-Rail Mounting

The DIN-Rail attachment plates are permanently fixed to the back panel of the EDS-728/828. Do not attempt to remove the attachment plates, since doing so could damage the product.

To Install:

Lock the brace by pressing the clips and then insert the top of the DIN-Rail into the notches at the bottom of the top array of heat radiating ribs. Press the EDS until the brace snaps into place.

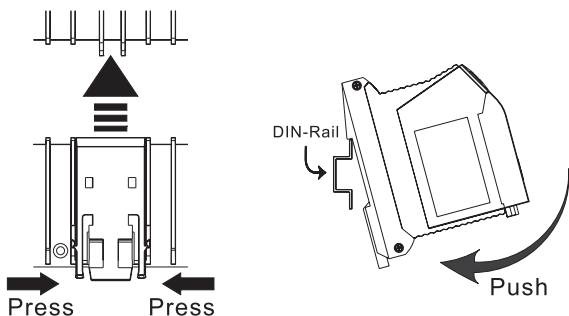

To Release:

Use a flat-blade screw driver as a lever to force the braces downwards, and then pull the EDS-728/828 out away from the DIN-Rail.

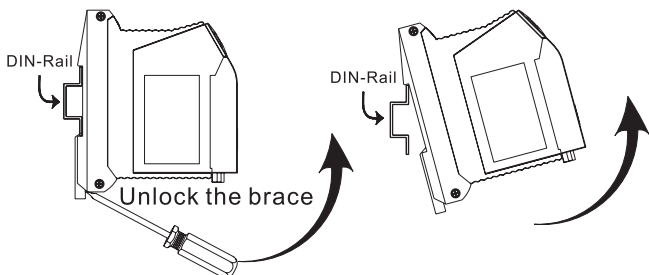

Wall Mounting (optional)

For some applications, you will find it convenient to mount the EDS-728/828 on the wall, as illustrated below.

STEP 1: Remove the aluminum DIN-Rail attachment plate from the EDS-728/828's rear panel, and then attach the wall mounting plates, as shown in the diagram.

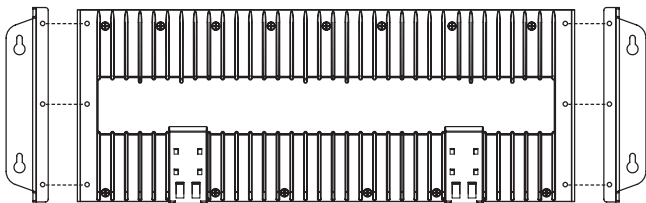

STEP 2:

Mounting the EDS-728/828 on the wall requires 4 screws to ensure that the switch does not come loose from the wall. Use the switch, with wall mounting plates attached, as a guide to mark the correct locations of the 4 screws. The heads of the screws should be less than 6.0 mm in diameter, and the shafts should be less than 3.5 mm in diameter, as shown in the figure at the right.

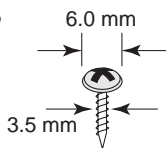

NOTE Before tightening the screws into the wall, make sure the screw head and shank size are suitable by inserting the screw into one of the keyhole-shaped apertures of the Wall Mounting Plates.

Do not screw the screws in all the way—leave about 2 mm to allow room for sliding the wall mount panel between the wall and the screws.

STEP 3: Once the screws are fixed in the wall, insert the four screw heads through the large parts of the keyhole-shaped apertures, and then slide Moxa EDS downwards, as indicated. Tighten the four screws for added stability.

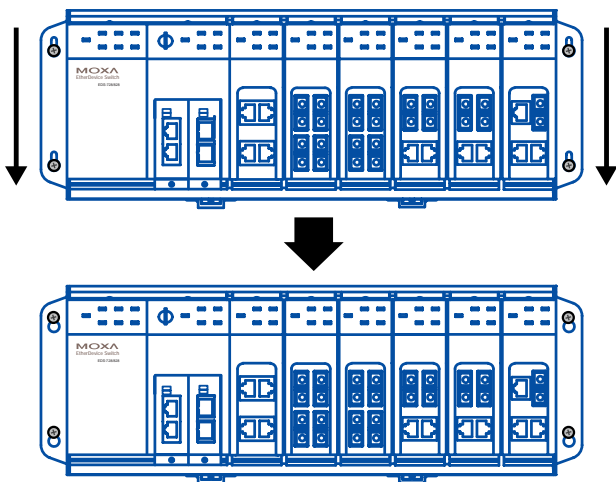

Uninstalling IM-2G Modules

As shown in the figure below, use a flat-blade screw driver as a lever, and pull or push it to force the IM-2G module outwards. Then pull the module out away from the EDS-728/828.

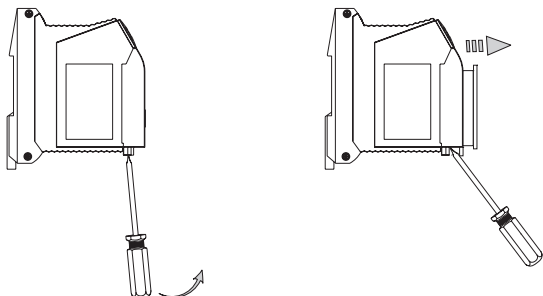

Wiring Requirements



WARNING

Safety First!

Be sure to disconnect the power cord before installing and/or wiring your Moxa EDS-728/828.

Calculate the maximum possible current in each power wire and common wire. Observe all electrical codes dictating the maximum current allowable for each wire size.

If the current goes above the maximum ratings, the wiring could overheat, causing serious damage to your equipment.

You should also pay attention to the following guidelines:

- Use separate paths to route wiring for power and devices. If power wiring and device wiring paths must cross, make sure the wires are perpendicular at the intersection point.
- NOTE: Do not run signal or communications wiring and power wiring in the same wire conduit. To avoid interference, wires with different signal characteristics should be routed separately.
- You can use the type of signal transmitted through a wire to determine which wires should be kept separate. The rule of thumb is that wiring that shares similar electrical characteristics can be bundled together.
- Keep input wiring and output wiring separated.
- It is strongly advised that you label wiring to all devices in the system when necessary.

Grounding Moxa EtherDevice Switch

Grounding and wire routing help limit the effects of noise due to electromagnetic interference (EMI). Run the ground connection from the ground screw, on the side panel of the EDS-728/828, to the grounding surface prior to connecting devices.



ATTENTION

This product is intended to be mounted to a well-grounded mounting surface, such as a metal panel.

Wiring the Relay Contact

In this section, we explain the meaning of the two contacts used to connect the alarm contact.

The EDS-728/828 has two sets of relay output—relay 1 and relay 2. Each relay contact consists of the two contacts of the terminal block on the EDS-728/828's top panel. Refer to the next section for detailed instructions on how to connect the wires to the terminal block connector, and how to attach the terminal block connector to the terminal block receptor.

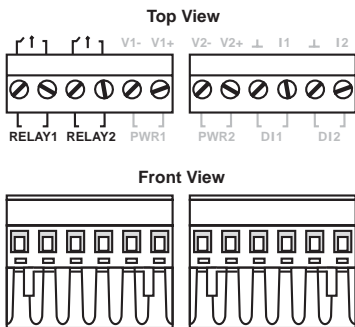

FAULT: The two sets of relay contacts of the 6-pin terminal block connector are used to detect user-configured events. The two wires attached to the Fault contacts form an open circuit when a user-configured event is triggered. If a user-configured event does not occur, the Fault circuit will be closed.

Wiring the Redundant Power Inputs

The EDS-728/828 has two sets of power input—power input 1 and power input 2. The top two contacts and the bottom two contacts of the 6-pin terminal block connector on EDS's top panel are used for EDS's two digital inputs.

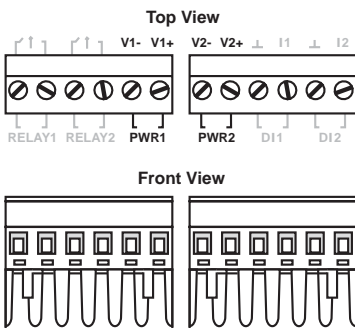

STEP 1: Insert the negative/positive DC wires into the V-/V+ terminals.

STEP 2: To keep the DC wires from pulling loose, use a small flat-blade screwdriver to tighten the wire-clamp screws on the front of the terminal block connector.

STEP 3: Insert the plastic terminal block connector prongs into the terminal block receptor, which is located on the EDS-728/828's top panel.

Wiring the Digital Inputs

The EDS-728/828 has two sets of digital input—DI 1 and DI 2. Each DI comprises two contacts of the 6-pin terminal block connector on EDS's top panel. The terminal block is also used for EDS's two DC inputs. Top and front views of one of the terminal block connectors are shown here.

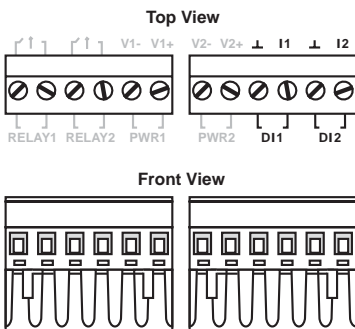

STEP 1: Insert the negative (ground)/ positive DI wires into the ⌊/I1 terminals.

STEP 2: To keep the DI wires from pulling loose, use a small flat-blade screwdriver to tighten the wire-clamp screws on the front of the terminal block connector.

STEP 3: Insert the plastic terminal block connector prongs into the terminal block receptor, which is located on the EDS-728/828's top panel.

Communication Connections

The pinout and cable wiring diagrams in this section show how the ports on the EDS-728/828 connect to other devices:

Pinouts are diagrams that indicate the type of signal passing through each of the port's pins.

- NOTE**
1. The pin numbers for male DB9 and DB25 connectors, and hole numbers for female DB9 and DB25 connectors are labeled *on the connector*. However, the numbers are typically quite small, so you may need to use a magnifying glass to see the numbers clearly.
 2. The pin numbers for both 8-pin and 10-pin RJ45 connectors (and ports) are typically *not* labeled on the connector (or port). Refer to the Pinout diagram below to see how RJ45 pins are numbered.

RS-232 Connection

The EDS-728/828 has one RS-232 (10-pin RJ45) console port, located on the front panel. Use either an RJ45-to-DB9 or RJ45-to-DB25 cable to connect the Moxa EDS-728/828's console port to your PC's COM port. You may then use a console terminal program to access the Moxa EDS-728/828's console configuration utility.

10-pin RJ45 Console Pinouts

10-Pin	Description
1	-----
2	DSR
3	-----
4	GND
5	TxD
6	RxD
7	GND
8	-----
9	DTR
10	-----

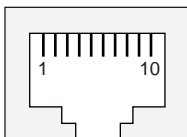

10/100BaseT(X) Ethernet Port Connection

Below we show pinouts for both MDI (NIC-type) ports and MDI-X (HUB/Switch-type) ports.

MDI Port Pinouts

Pin	Signal
1	Tx+
2	Tx-
3	Rx+
6	Rx-

MDI-X Port Pinouts

Pin	Signal
1	Rx+
2	Rx-
3	Tx+
6	Tx-

8-pin RJ45

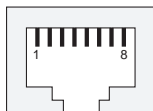

1000BaseT Ethernet Port Connection

1000BaseT data is transmitted on differential TRD+/- signal pairs over copper wires.

MDI/MDI-X Port Pinouts

Pin	Signal
1	TRD(0)+
2	TRD(0)-
3	TRD(1)+
4	TRD(2)+
5	TRD(2)-
6	TRD(1)-
7	TRD(3)+
8	TRD(3)-

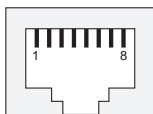

100/1000Base Fiber Port Connection

The concept behind the duplex port and cable is quite straightforward. Suppose you are connecting devices I and II. Contrary to electrical signals, optical signals do not require a circuit in order to transmit data. Consequently, one of the optical lines is used to transmit data from device I to device II, and the other optical line is used to transmit data from device II to device I, for full-duplex transmission.

All you need to remember is to connect the Tx (transmit) port of device I to the Rx (receive) port of device II, and the Rx (receive) port of device I to the Tx (transmit) port of device II. If you make your own cable, we suggest labeling the two sides of the same line with the same letter (A-to-A and B-to-B or A1-to-A2 and B1-to-B2).



ATTENTION

This is a Class 1 Laser/LED product. To avoid causing serious damage to your eyes, do not stare directly into the Laser Beam.

LED Indicators

LED	Color	State	Description
System LEDs			
STAT	GREEN	On	System has passed self-diagnosis test on boot-up and is ready to run.
		Blinking	System is undergoing the self-diagnosis test.
	RED	On	System failed self-diagnosis on boot-up.
PWR1	AMBER	On	Power is being supplied to the main module's power input PWR1.
		Off	Power is not being supplied to the main module's power input PWR1.
PWR2	AMBER	On	Power is being supplied to the main module's power input PWR2.
		Off	Power is not being supplied to the main module's power input PWR2.
FAULT	RED	On	The corresponding PORT alarm is enabled and a user-configured event has been triggered.
		Off	The corresponding PORT alarm is enabled and a user-configured event has not been triggered, or the corresponding PORT alarm is disabled.

MASTER	GREEN	On	This EDS-728/828 is the Master of this Turbo Ring.
		Blinking	This EDS-728/828 has become Ring Master of this Turbo Ring after the Turbo Ring was broken.
		Off	This EDS-728/828 is not the Master of this Turbo Ring.
COUPLER	GREEN	On	When this EDS-728/828 enables the coupling function to form a back-up path.
		Off	When this EDS-728/828 disables the coupling function.
T.RING	GREEN	Off	This EDS-728/828 does not belong to an active Turbo Ring.
		On	This EDS-728/828 belongs to an active Turbo Ring.

NOTE Use the Mode push-button switch to cycle among the LNK/ACT, SPEED, FDX/HDX, RING PORT, and COUPLER PORT LEDs. The status of these five settings is indicated by the LEDs for the various ports.

LED	Color	State	Description
Mode LEDs			
LNK/ACT	GREEN	On	The corresponding module port's link is active.
		Blinking	The corresponding module port's data is being transmitted.
		Off	The corresponding module port's link is inactive.
FDX/HDX	GREEN	On	The corresponding module port's data is being transmitted at full duplex.
		Off	The corresponding module port's data is not being transmitted.
RING PORT	GREEN	On	The corresponding module's port is the ring port of this EDS-728/828.
		Off	The corresponding module's port is not the ring port of this EDS-728/828.
COUPLER	GREEN	On	The corresponding module's port is the coupler port of this EDS-728/828.
		Off	The corresponding module's port is not the coupler port of this EDS-728/828.
SPEED	GREEN	Off	The corresponding module port's data is being transmitted at 10 Mbps.
		On	The corresponding module port's data is being transmitted at 100 Mbps.
		Blinking	The corresponding module port's data is being transmitted at 1000 Mbps.

Fast Ethernet Module LEDs

PWR	GREEN	On	Power is being supplied to the interface module.
		Off	Power is not being supplied to the interface module.
P1/P2/ P3/P4	GREEN	On/ Off/ Blinking	Displays the module port's status by mode.

Gigabit Ethernet Module LED

P1/P2	GREEN	On/ Off/ Blinking	Displays the module port's status by mode.
--------------	-------	-------------------------	--

Specifications

Modular Managed Switch System, EDS-72810G/82810G

Modular Managed Switch System with 6 slots, and up to 28 ports.

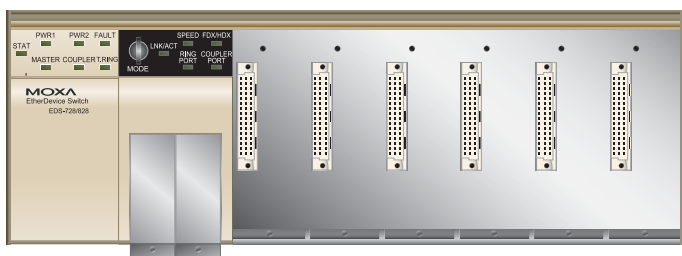

Technology

Standards	IEEE802.3, 802.3u, 802.3x, 802.1D, 802.1w, 802.1Q, 802.1p, 802.1X, 802.3ad, 802.3z
Protocols	IGMP Snooping, GMRP, GVRP, SNMP V1/V2C/V3, DHCP Server/Client, BOOTP, TFTP, SNTP, SMTP, RARP, RMON, and RIP V1/V2 (EDS-828 only)
MIB	MIB-II, Ethernet-Like MIB, P-BRIDGE MIB, Q-BRIDGE MIB, Bridge MIB, RSTP MIB, RMON MIB Groups 1, 2, 3, 9
Flow Control	IEEE802.3x flow control/back pressure
Interface	
Fast Ethernet	6 slots for any combination of 4-port Interface Modules with 10/100BaseT(X) or 100BaseFX
Gigabit Ethernet	2 sockets for any combination of 2-port Interface Modules with 10/100/1000BaseT(X), and 1000BaseSX/LX/LHX/ZX SFP modules
Console	RS-232 (RJ45)
System LED Indicators	STAT, PWR1, PWR2, FAULT, MASTER, COUPLER, T.RING
Module LED Indicators	LNK/ACT, FDX/HDX, RING PORT, COUPLER, PORT, SPEED
Alarm Contact	Two relay outputs with current carrying capacity of 1A @ 24 VDC

Digital Inputs	Two inputs with the same ground, but electrically isolated from the electronics. <ul style="list-style-type: none"> • For state “1”: +13 to +30V • For state “0”: -30 to +3V • Max. input current: 8 mA 																						
Power																							
Input Voltage	24 VDC (12 to 45 VDC), redundant dual inputs																						
Connection	Two removable 6-pin terminal blocks																						
Power Consumption	<table> <tr> <td>EDS-72810G/82810G</td> <td>22.9W</td> </tr> <tr> <td>IM-4TX</td> <td>2.5W</td> </tr> <tr> <td>IM-2MSC/2TX</td> <td>5W</td> </tr> <tr> <td>IM-2MST/2TX</td> <td>5W</td> </tr> <tr> <td>IM-2SSC/2TX</td> <td>5W</td> </tr> <tr> <td>IM-4MSC</td> <td>7.2W</td> </tr> <tr> <td>IM-4MST</td> <td>7.2W</td> </tr> <tr> <td>IM-4SSC</td> <td>7.2W</td> </tr> <tr> <td>IM-1LSC/3TX</td> <td>4W</td> </tr> <tr> <td>IM-2GTX</td> <td>3W</td> </tr> <tr> <td>IM-2GSFP</td> <td>3W</td> </tr> </table>	EDS-72810G/82810G	22.9W	IM-4TX	2.5W	IM-2MSC/2TX	5W	IM-2MST/2TX	5W	IM-2SSC/2TX	5W	IM-4MSC	7.2W	IM-4MST	7.2W	IM-4SSC	7.2W	IM-1LSC/3TX	4W	IM-2GTX	3W	IM-2GSFP	3W
EDS-72810G/82810G	22.9W																						
IM-4TX	2.5W																						
IM-2MSC/2TX	5W																						
IM-2MST/2TX	5W																						
IM-2SSC/2TX	5W																						
IM-4MSC	7.2W																						
IM-4MST	7.2W																						
IM-4SSC	7.2W																						
IM-1LSC/3TX	4W																						
IM-2GTX	3W																						
IM-2GSFP	3W																						
Overload Current Protection	Present																						
Reverse Polarity Protection	Present																						
Mechanical																							
Casing	IP30 protection																						
Dimensions	362 x 146 x 128 mm (W x H x D)																						
Weight	1850g																						
Installation	DIN-Rail, Wall Mounting (optional kit)																						

Gigabit Ethernet Interface Module, IM-2G Series

IM-2GTX: Interface Module with 2 10/100/1000BaseT(X) ports, RJ45 connectors.

IM-2GSFP: Interface Module with 2 1000BaseSX/LX/LHX/ZX SFP sockets for SFP modules.

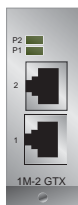

IM-2GTX



IM-2GSFP

Interface

LED Indicators	P1, P2 for Port Status
RJ45 Ports	10/100/1000BaseT(X) auto negotiation speed, and auto MDI/MDI-X connection
Distance	100 m
Fiber Ports	1000BaseSX/LX/LHX/ZX (SFP socket)

Optical Fiber/SFP-1GxxxLC Series

	SX	LX	LHX	ZX
Wavelength	850 nm	1310 nm	1310 nm	1310 nm
Max. Tx	-4 dBm	-3 dBm	1 dBm	+5 dBm
Min. Tx	-9.5 dBm	-9.5 dBm	-4 dBm	0 dBm
Rx Sensitivity	-18 dBm	-20 dBm	-24 dBm	-24 dBm
Link Budget	8.5 dB	10.5 dB	20 dB	24 dB
Typical Distance	550m (a) 275m (b)	1100m (c) 550m (d) 10km (e)	40km (e)	80km (f)
Saturation	0 dBm	-3 dBm	-3 dBm	-3 dBm

a. [50/125 μ m, 400 MHz*km] cable
b. [62.5/125 μ m, 200 MHz*km] cable
c. [50/125 μ m, 800 MHz*km] cable
d. [62.5/125 μ m, 500 MHz*km] cable
e. [9/125 μ m, 3.5 PS/(nm*km)] cable
f. [9/125 μ m, 19 PS/(nm*km)] cable

	10A	10B	20A	20B	40A	40B
Wavelength	TX: 1310nm RX: 1550nm	TX: 1550nm RX: 1310nm	TX: 1310nm RX: 1550nm	TX: 1550nm RX: 1310nm	TX: 1310nm RX: 1550nm	TX: 1550nm RX: 1310nm
Max. Tx	-3 dBm	-3 dBm	-2 dBm	-2 dBm	+2 dBm	+2 dBm
Min. Tx	-9 dBm	-9 dBm	-8 dBm	-8 dBm	-3 dBm	-3 dBm
Rx Sensitivity	-21 dBm	-21 dBm	-23 dBm	-23 dBm	-23 dBm	-23 dBm
Link Budget	12 dB	12 dB	15 dB	15 dB	20 dB	20 dB
Typical Distance	10 km	10 km	20 km	20 km	40 km	40 km
Saturation	-1 dBm	-1 dBm	-1 dBm	-1 dBm	-1 dBm	-1 dBm

a. [50/125 μ m, 400 MHz*km] cable
b. [62.5/125 μ m, 200 MHz*km] cable
c. [50/125 μ m, 800 MHz*km] cable
d. [62.5/125 μ m, 500 MHz*km] cable
e. [9/125 μ m, 3.5 PS/(nm*km)] cable
f. [9/125 μ m, 19 PS/(nm*km)] cable

Mechanical

Dimensions 24 x 66 x 101 mm (W x H x D)

Weight IM-2GTX 150g
IM-2GSFP 148g

Fast Ethernet Interface Module, IM series

IM-4TX: Interface Module with 4 10/100BaseT(X) ports, RJ45 connectors.

IM-4MSC: Interface Module with 4 multi mode 100BaseFX ports, SC connectors.

IM-4MST: Interface Module with 4 multi mode 100BaseFX ports, ST connectors.

IM-4SSC: Interface Module with 4 single mode 100BaseFX ports, 40 km SC connectors.

IM-2MSC/2TX: Interface Module with 2 multi mode 100BaseFX ports, SC connectors, and 2 10/100BaseT(X) ports, RJ45 connectors.

IM-2MST/2TX: Interface Module with 2 multi mode 100BaseFX ports, ST connectors, and 2 10/100BaseT(X) ports, RJ45 connectors.

IM-2SSC/2TX: Interface Module with 2 single mode 100BaseFX ports, 40 km SC connectors, and 2 10/100BaseT(X) ports, RJ45 connectors.

IM-1LSC/3TX: Interface Module with 1 single mode 100BaseFX port, 80 km SC connector and 3 10/100BaseT(X) ports, RJ45 connectors.

IM-4TX	IM-4MSC, IM-4SSC,	IM-4MST	IM-2MSC/ 2TX IM-2SSC/ 2TX	IM-2MST/ 2TX	IM-1LSC/ 3TX

Interface

LED Indicators	PWR, P1, P2, P3, P4 port status
RJ45 Ports	10/100/1000BaseT(X) auto negotiation speed, F/H duplex mode, and auto MDI/MDI-X connection
Distance	100 m
Fiber Ports	100BaseFX ports (SC/ST connector)

Optical Fiber

	Multi-mode	Single-mode	Single-mode, 80 km
Wavelength	1300 nm	1310 nm	1550 nm
Max. Tx	-10 dBm	0 dBm	0 dBm
Min. Tx	-20 dBm	-5 dBm	-5 dBm
Rx Sensitivity	-32 dBm	-34 dBm	-34 dBm
Link Budget	12 dB	29 dB	29 dB
Typical Distance	5 km (a) 4 km (b)	40 km (c)	80 km (d)
Saturation	-6 dBm	-3 dBm	-3 dBm

a. using [50/125 μm , 800 MHz*km] cable
 b. using [62.5/125 μm , 500 MHz*km] cable
 c. using [9/125 μm , 3.5 PS/(nm*km)] cable
 d. using [9/125 μm , 19 PS/(nm*km)] cable

Mechanical

Casing	IP30 protection
Dimensions	40 x 130 x 100 mm (W x H x D)
Weight	IM-4TX 215 g IM-2MSC/2TX 245 g

IM-2MST/2TX	250 g
IM-2SSC/2TX	245 g
IM-1LSC/3TX	235 g
IM-4MSC	250 g
IM-4MST	270 g
IM-4SSC	270 g

Environmental

Operating Temperature	0 to 60°C (32 to 140°F)
Storage Temperature	-40 to 85°C (-40 to 185°F)
Ambient Relative Humidity	5 to 95% (non-condensing)

Regulatory Approvals

Safety	UL60950-1, CSA C22.2 No. 60950-1, EN60950-1 (Pending), UL508 (Pending)
Hazardous Location	UL/cUL Class I, Division 2, Groups A, B, C and D (Pending) ATEX Class I, Zone 2, EEx nC IIC (Pending)
EMI	FCC Part 15, CISPR (EN55022) class A
EMS	EN61000-4-2 (ESD), Level 3 EN61000-4-3 (RS), Level 3 EN61000-4-4 (EFT), Level 4 EN61000-4-5 (Surge), DC Input: level 4; Comm. Line: level 3 EN61000-4-6 (CS), Level 3 EN61000-4-8 EN61000-4-11 EN61000-4-12
Shock	IEC60068-2-27
Freefall	IEC60068-2-32
Vibration	IEC60068-2-6
WARRANTY	5 years

Moxa Internet Services

Customer satisfaction is our number one concern, and to ensure that customers receive the full benefit of our products, Moxa has set up on-line support services to provide technical support, driver updates, product information, and user's manual updates.

E-mail for technical support:

support@moxa.com (Worldwide)
support@usa.moxa.com (The Americas)

Website for up to date product information: www.moxa.com

Free Manuals Download Website

<http://myh66.com>

<http://usermanuals.us>

<http://www.somanuals.com>

<http://www.4manuals.cc>

<http://www.manual-lib.com>

<http://www.404manual.com>

<http://www.luxmanual.com>

<http://aubethermostatmanual.com>

Golf course search by state

<http://golfingnear.com>

Email search by domain

<http://emailbydomain.com>

Auto manuals search

<http://auto.somanuals.com>

TV manuals search

<http://tv.somanuals.com>