



OPERATING INSTRUCTIONS AND OWNER'S MANUAL

Model #

MHT 45

READ INSTRUCTIONS CAREFULLY: Read and follow all instructions. Place instructions in a safe place for future reference. Do not allow anyone who has not read these instructions to assemble, light, adjust or operate the heater.

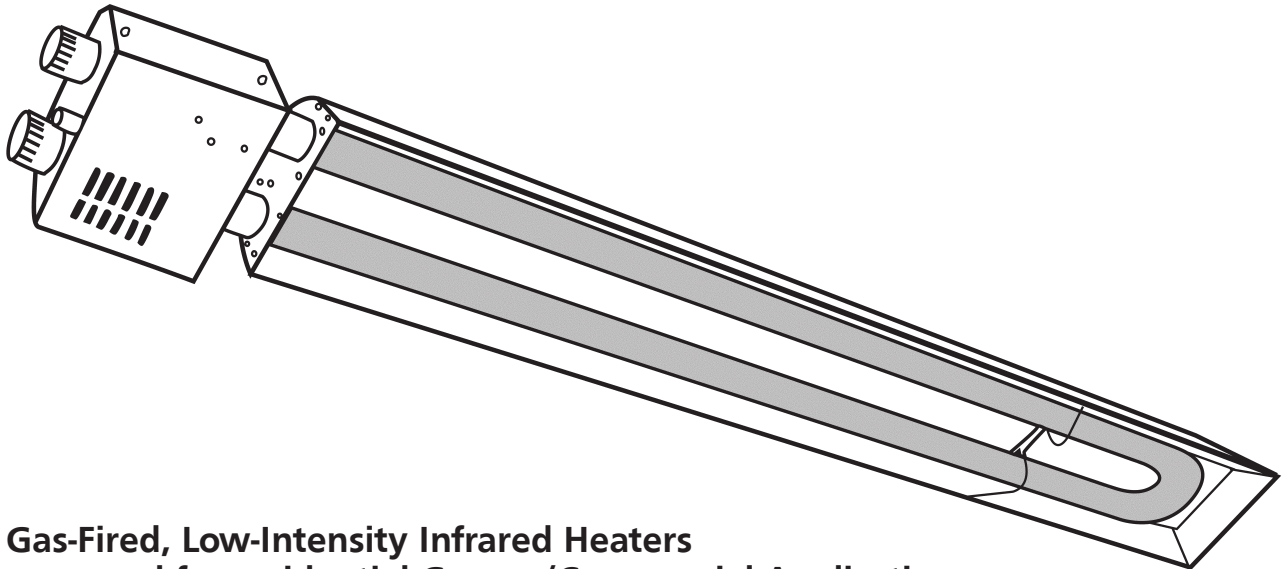

**Gas-Fired, Low-Intensity Infrared Heaters
approved for residential Garage/Commercial Applications**

WARNING: Improper installation, adjustment, alteration, service or maintenance can cause injury or property damage. Refer to this manual. For assistance or additional information consult a qualified installer, service agency or the gas supplier.

– WHAT TO DO IF YOU SMELL GAS

- Open Windows
- **DO NOT** try to light any appliance.
- **DO NOT** use electrical switches.
- **DO NOT** use any telephone in your house. Immediately call your local gas supplier from a neighbor's telephone. Follow the gas supplier's instructions.
- **Do not** touch any electrical switch; do not use any phone in your building.
- Installation and service must be performed by a qualified installer, service agency or the gas supplier.
- If you cannot reach your gas supplier, call the Fire Department.

FOR YOUR SAFETY:

Do not store or use gasoline or other flammable vapors and liquids in the vicinity of this or any other appliance.

WARNING: If the information in these instructions are not followed exactly, a fire or explosion may result causing property damage, personal injury or loss of life.

WARNING:

⚠ YOUR SAFETY IS IMPORTANT TO YOU AND TO OTHERS, SO PLEASE READ THESE INSTRUCTIONS BEFORE YOU OPERATE THIS HEATER.

L'AVERTISSEMENT:

⚠ Votre surete est importante a vous et donc s'il vous plait lire ces instructions avant d'operer cet appareil de chauffage.

GENERAL HAZARD WARNING:

- ⚠ FAILURE TO COMPLY WITH THE PRECAUTIONS AND INSTRUCTIONS PROVIDED WITH THIS HEATER, CAN RESULT IN DEATH, SERIOUS BODILY INJURY AND PROPERTY LOSS OR DAMAGE FROM HAZARDS OF FIRE, EXPLOSION, BURN, ASPHYXIATION, CARBON MONOXIDE POISONING, AND/OR ELECTRICAL SHOCK.
- ⚠ ONLY PERSONS WHO CAN UNDERSTAND AND FOLLOW THE INSTRUCTIONS SHOULD USE OR SERVICE THIS HEATER.
- ⚠ IF YOU NEED ASSISTANCE OR HEATER INFORMATION SUCH AS AN INSTRUCTIONS MANUAL, LABELS, ETC. CONTACT THE MANUFACTURER.

L'AVERTISSEMENT GENERAL DE DANGER:

- ⚠ L'Echec pour se conformer aux precautions et aux instructions a fourni avec cet appareil de chauffage, avoir pour resultat la mort blessure et la perte de propriete ou les dommages physiques serieuses du danger de feu, l'explosion, la brulure l'asphyxie, monoxyde de carbone empoisonant, et/ou le choc electrique.
- ⚠ Seulement les personnes qui peuvent comprendre et peut suibre les instructions doivent utiliser ou doivent entretenir cet appareil de chauffage.
- ⚠ Si vous avez besoin de l'information d'assistance ou appareil de chauffage telle qu'un manuel d'instruction, les etiquettes,etc, contactez le fabricant

WARNING:

⚠ FIRE, BURN, INHALATION, AND EXPLOSION HAZARD. KEEP SOLID COMBUSTIBLES, SUCH AS BUILDING MATERIALS, PAPER OR CARDBOARD, A SAFE DISTANCE AWAY FROM THE HEATER AS RECOMMENDED BY THE INSTRUCTIONS NEVER USE THE HEATER IN SPACES WHICH DO OR MAY CONTAIN VOLATILE OR AIRBORNE COMBUSTIBLES, OR PRODUCTS SUCH AS GASOLINE, SOLVENTS, PAINT THINNER, DUST PARTICLES OR UNKNOWN CHEMICALS.

L'AVERTISSEMENT:

- ⚠ Le feu, les brulures, le danger d'inhalation et explosion garder combustibles solide tel que les materiels de papier ou le carton.
- ⚠ Une distance sure eloigne de l'appareil chauffage comme recommande.
- ⚠ Par les instructions, ne utiliser l'appareil de chauffage dans les espaces qui forme contenir combustibles volatil ou aeroporte, ou les produit qu'essence, les disolvants, peindre plus mines, les particles de poussiere ou les produits chimiques inconnus

WARNING:

⚠ **The State of California requires the following warning:** COMBUSTION BY-PRODUCTS PRODUCED WHEN USING THIS PRODUCT CONTAIN CARBON MONOXIDE, A CHEMICAL KNOWN TO THE STATE OF CALIFORNIA TO CAUSE CANCER AND BIRTH DEFECTS (OR OTHER REPRODUCTIVE HARM).

L'AVERTISSEMENT:

⚠ **L'etat de Californie exige les avertissement siuivants.** Derives de combustion ont produit en utilisant ce produit contient monoxyde de carbone, un chimique/gaz connu dans l'etat de californie pour causer les defauts de cancer et naissance (ou autre le mal reproducteur)

CONTENTS

Section 1 INTRODUCTION.....	3
Section 2 PLANNING	6
Section 3 INSTALLATION.....	8
Section 4 VENTING.....	12
Section 5 OPERATION.....	18
Section 6 MAINTENANCE.....	19
Section 7 TROUBLESHOOTING	20
Section 8 ILLUSTRATED PARTS	22
WARRANTY	24
INSTRUCTIONS FOR ORDERING PARTS.....	24

BEFORE YOU BEGIN

Read this manual carefully before installing or servicing this equipment. Improper installation, servicing or maintenance will cause death, injury or property damage. Check the minimum required safe distances from combustibles given on the outside of each burner to make sure that the product is suitable for your application. The minimum required safe distances from combustibles is also found on page 9 of this manual. Installer must be a licensed contractor or representative. After the installation is complete, check product operation as provided in these instructions.

Unpacking the Heater

Manpower Requirements

To prevent personal injury and damage to the heater, two persons will be required to remove the heater from the carton. Both ends of the heater should be lifted from the carton at the same time. The burner box should be lifted by gripping the bottom of the box. The reflector end of the heater should be lifted using the rear moveable hanger.

Safety

Thin sheet metal parts, such as the reflector portion of the heater and the various venting components, have sharp edges. To prevent injury, the use of work gloves is recommended. The use of gloves will also prevent the transfer of body oils from the hands to the surface of the reflector.

Section 1 INTRODUCTION

About The Heater

The MHT 45 is a factory-assembled, gas fired, low-intensity heating system. The system has been designed for easy installation and will provide years of economical operation and trouble-free service. Not only is infrared heat efficient, it also provides the most comfortable conditions in open areas, such as garages.

Gas-Fired means it uses clean-burning Natural or LP gas.

Low-Intensity means that the radiant surface of the heat exchanger tube does not glow red. Instead, it operates at a lower temperature (less than 1000 F) and radiates energy at a lower intensity per square foot of radiating surface. The lower temperature and intensity levels are within a range that is most effective in establishing and maintaining personal comfort levels. An aluminum reflector directs the radiant energy downward to the occupied area.

Radiant refers to the energy radiated by the tube heater. Because the energy is in the form of infrared rays, it does not directly heat the air. Instead, the rays heat objects such as the floor, cars, machines and people. The warm objects, in turn, heat the air. These combined features are the key to the exceptional comfort and fuel efficiency provided by the tube heater.

Available Accessories

Vent Kit (F102840)

1. (2) 3" x 2' Pipe 26GA.
2. (1) 36" x 3" B-Vent
3. (1) Gas Vent Top 3"
4. (1) Adj. Wall Thimble
5. (1) Storm Collar
6. (1) 3" Elbow
7. (1) Adj. Roof Flashing

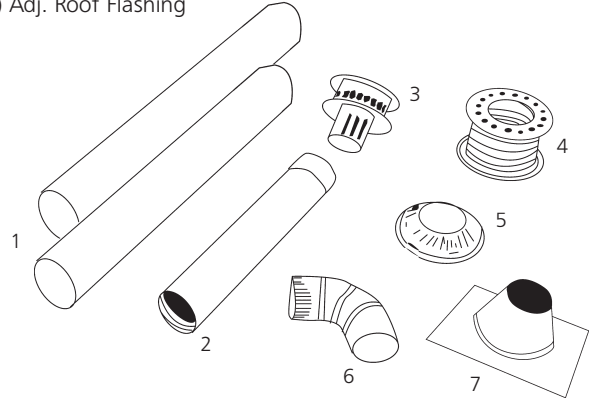

About The Heater

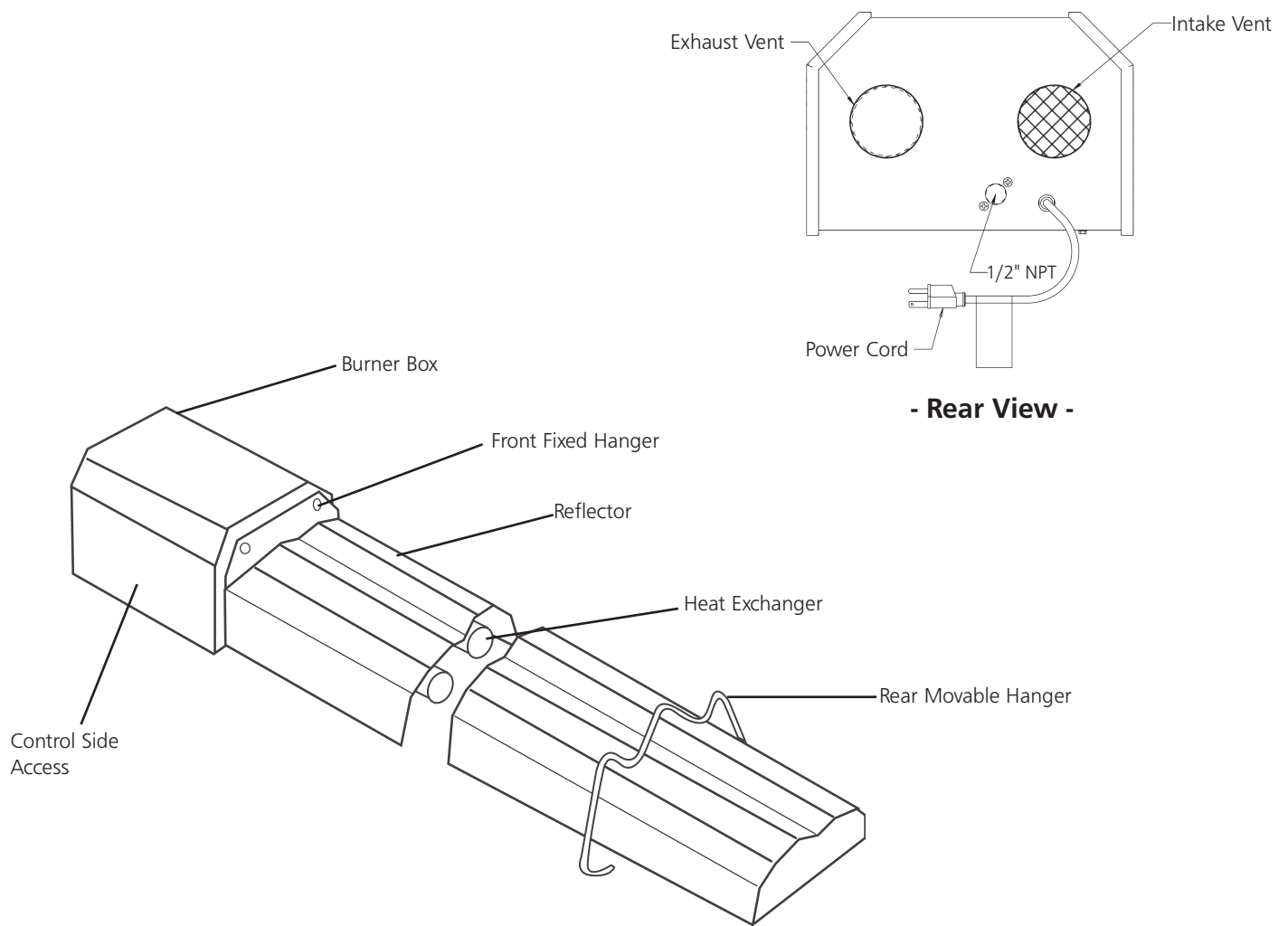

- Rear View -

Burner Box	Contains the electrical components (i.e. blower motor, power transformer, etc.) and gas distribution components (i.e. gas valve, etc.) that make the heater work. There are no owner serviceable items contained in this box.
Front Fixed Hanger	Provides rigid support and mounting surface for the reflector. Holes are provided in the upper corners of the bulkhead to accommodate suspension hardware required for installation of the heater.
Reflector heated.	The reflector is made from formed aluminum and reflects the radiant energy downward to the space to be heated.
Heat Exchanger	A U-shaped tube through which the heated products of combustion pass.
Rear Movable Hanger	Provides support for the heat exchanger and reflector at the end that is furthest from the burner box. The support may be moved (within limits) to accommodate hanging of the unit.
Service Door	To be removed only by a licensed contractor. Removal of this service door provides access to the electrical and gas distribution components.
Intake Vent	Accommodates a 3" diameter combustion air inlet duct that delivers fresh air to the burner.
Exhaust Vent	Accommodates the air-venting duct that carries the products of combustion to be vented outdoors.
Nipple – 1/2 NPT	Point at which the gas supply is connected to the heater.
Power Cord	Includes a three prong plug that must be connected to a dedicated and properly grounded three prong ceiling outlet.

Technical Specifications:

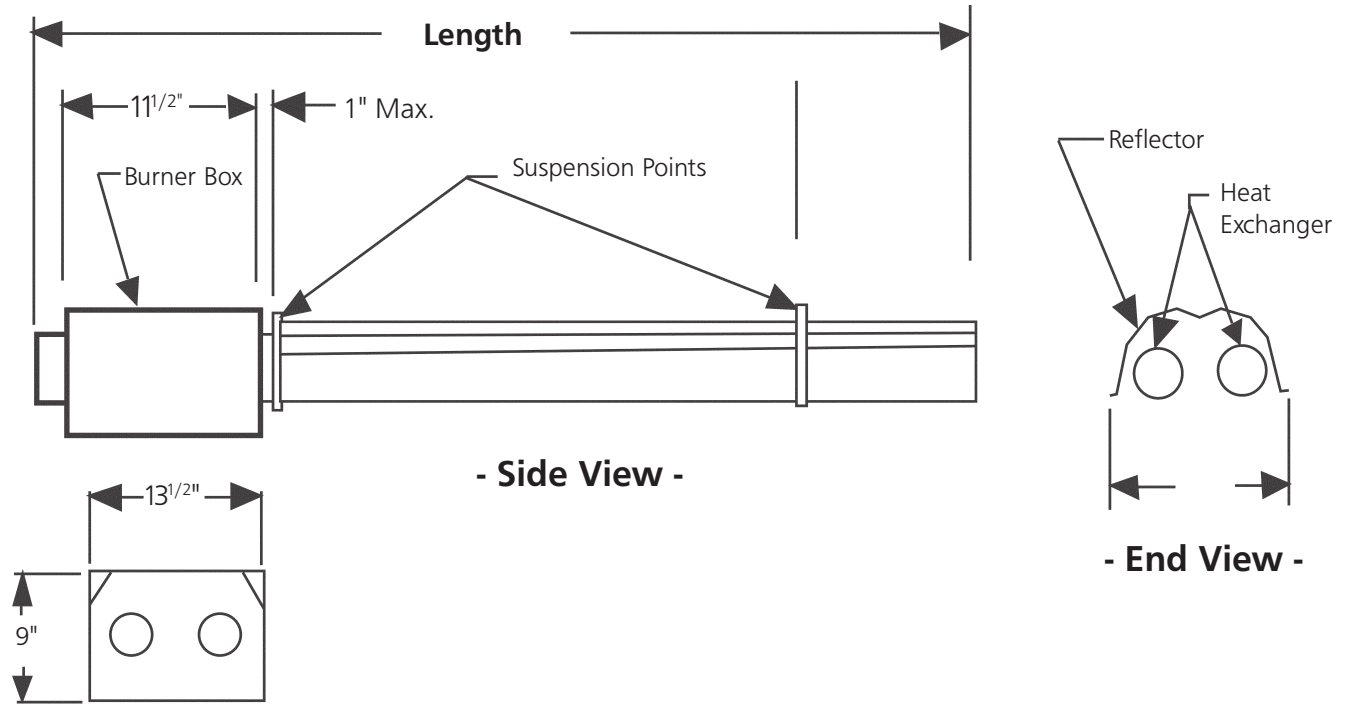

Leading Particulars			
Model No.	BTU/hr	Weight	Length
MHT-45	45,000	96 lbs.	10'

HEATER SPECIFICATIONS

Electrical

Rating: 120VAC, 60Hz, single phase, 1 amp

Connection: 3 pin molded plug

Gas Inlet Connection

Connection 1/2" Male NPT

Gas Inlet Pressure

The minimum inlet gas supply pressure for the purpose of input adjustment.

Natural Gas:

Minimum - Inlet 5.0" w.c.

Maximum - Inlet 10.5" w.c.

LP Gas (propane):

Minimum - Inlet 11.0" w.c.

Maximum - Inlet 13.0" w.c.

Manifold Pressure

Natural Gas: 4.0" w.c.

LP Gas (propane): 10.0" w.c.

VENTING SPECIFICATIONS

Vent/Flue

Length - 25 feet (Maximum)

5 feet (Minimum)

Flue Pipe - 3.0" diameter

Vent Pipe - 3" diameter

Where can the heater be installed?

The MHT tube heater is intended for installation in the following areas:

- Residential applications, such as:
 - garages
 - greenhouses
 - workshops
- Light industrial/commercial applications, such as:
 - entranceways
 - lobby areas
 - Lunch rooms
 - aircraft hangars (see Section 2 for restrictions)
 - public garages (see Section 2 for restrictions)

Where can't the heater be installed?

The MHT tube heater is not intended for installation in the following areas:

- Residential living or sleeping areas
- Basements

Installer's responsibility

The MHT tube heater, as well as the gas and electrical supply, and the venting of the heater must be installed in accordance with applicable specifications and codes. Only firms (or individuals) well qualified in this type of work should install the system. Consult local Building Inspectors, Fire Marshals for further guidance.

Use the information given in this manual together with the cited codes and regulations to perform the installation. The installer must furnish all needed materials that are not furnished as standard equipment. It is also the installer's responsibility to see that the materials and installation methods used, result in a job that is workmanlike in appearance and is in compliance with all applicable codes and requirements to this manual. The installer must give this manual to the owner.

Section 2 PLANNING

General

This section provides the following information:

- Defines the gas, electric and venting requirements for the MHT tube heater.
- Specifies the national standards and applicable codes that apply to the gas, electric and venting requirements.
- Specifies the national standards and applicable codes that apply to non-residential installations.

Gas Service Requirements: System Requirements

Inlet Connection

Connection: 1/2" Male NPT

Inlet Pressure

Natural Gas:

Minimum - Inlet 5.0" w.c.

Maximum - Inlet 10.5" w.c.

LP Gas (propane):

Minimum - Inlet 10.5" w.c.

Maximum - Inlet 13.0" w.c.

Manifold Pressure

Natural Gas: 4.0" w.c.

LP Gas (propane): 10.0" w.c.

Type of Gas

The type of gas appearing on the nameplate must be the type of gas used. Installation must comply with local codes and recommendations of the local gas company. United States: Refer to National Fuel Gas Code, ANSI Z223.1 - latest revision, (same as NFPA Bulletin 54). Canada: Refer to Can 1-B149.1: Installation Codes for Gas Burning Appliances.

Gas Supply Lines

The size of the gas supply lines must comply with local codes and recommendations of the local gas company. United States: Refer to National Fuel Gas Code, ANSI Z223.1 - latest revision, (same as NFPA Bulletin 54). Canada: Refer to CAN 1-B149.1: Installation Codes for Gas Burning Appliances.

A 1/8" NPT plugged tap must be installed in the gas line connection immediately upstream of the heater that is farthest from the gas supply meter. The tap is required for checking system gas pressure.

Meter and Service

Meter and service must be large enough to handle all the heaters being installed plus any other connected load. The gas line which feeds the system must be large enough to supply the required gas with a maximum pressure drop of 1/2" w.c. When gas piping is not included in the layout drawing, the local gas supplier will usually help in planning the gas piping.

Electrical Service Requirements: System Requirements

The MHT tube heater requires a grounded three-prong electrical outlet to be installed within 18 inches of the rear surface of the heater's burner box. It is recommended that the outlet for the heater be ceiling-mounted and should be on a dedicated circuit. **DO NOT** use an electrical extension cord to operate the heater.

Heater Rating: 120 VAC, 60 Hz, Single Phase, 1 Amp

⚠ WARNING

Electrical Shock Hazard
Plug heater into grounded three-prong ceiling receptacle.
Do not cut or remove the grounding prong from this plug.
Do not use with an extension cord.
Failure to follow these instructions will result in death or electrical shock.

⚠ ATTENTION

Risque d'électrocution
Brancher le cordon du radiateur sur un socle à 3 broches et à la masse, situé au plafond.
Ne pas sectionner ou retirer la broche de masse de cette prise.
N'utiliser aucun câble de rallonge.
Le non-respect de ces consignes peut entraîner mort ou électrocution.

Grounding

The heater must be electrically grounded in accordance with the following codes: **United States:** Refer to National Electrical Code ANSI/NFPA-70 – latest revision. Wiring must conform to the most current National Electrical Code and local ordinances. **Canada:** Refer to Canadian Electrical Code, CSA C22.1 Part 1 – latest revision.

Venting Requirements: System Requirements

The MHT tube heater must be installed with venting or with one of the optional venting kits available from Enerco. **DO NOT** connect this heater to a separate chimney. Gas appliances must not be connected to a chimney flue serving a separate solid-fuel burning appliance. **DO NOT** common vent with any other fuel burning appliance.

Maximum Length: 25 feet

Minimum Length: 5 feet

⚠ WARNING

Carbon Monoxide Hazard
Heater must be exhausted outside.
Use materials supplied.
Failure to follow these instructions will result in death or injury.

⚠ ATTENTION

Risque de monoxyde de carbone
L'échappement du radiateur doit s'effectuer à l'extérieur.
Utilisez le matériel fourni.
Le non-respect de ces consignes peut entraîner mort ou blessures.

Venting Codes

The location, size, installation and termination of vents, as well as the minimum required safe distances when penetrating combustible walls, must comply with local codes and recommendations of the local gas company. **United States:** Refer to National Fuel Gas Code, ANSI Z223.1 – latest revision, (same as NFPA Bulletin 54). **Canada:** Refer to Can 1-B149.1 : Installation Codes for Gas Burning Appliance.

Non-residential Installations: Aircraft Hangars

The MHT tube heater may be used in certain areas of aircraft hangars. Installation in aircraft hangars must be in accordance with the following codes: United States: Refer to Standard for Aircraft Hangars, ANSI/NFPA-409 – latest revision. Canada: Refer to Standard CGA B149-1M91.

Heaters in aircraft storage or service areas must be installed a minimum of 10 feet above the upper surface of wings or engine enclosures of the highest aircraft which may be housed in the hangar. (This should be measured from the bottom of the heater to the top of the wing, or engine enclosure, whichever is highest from the floor).

In other sections of aircraft hangars, such as shops or office, heaters must be installed a minimum of 8 feet above the floor.

Heaters installed in aircraft hangars shall be located so as not to be subject to damage by aircraft, cranes, movable scaffolding or other objects.

When installed over hoists, the minimum required safe distances to combustibles must be maintained from the uppermost point of the combustible materials placed on the hoist.

Public Garages

The MHT tube heater may be used in public garages. Installation in public garages must be in accordance with the following codes: United States: Standard for Parking Structures NFPA-88A – Latest revision, or the Standard for Repair Garages, NFPA-88B – latest revision. Canada: Refer to Can 1-B149.1: Installation Codes for Gas Burning Appliances.

Heaters must be installed a minimum of eight feet above the floor. Minimum required safe distances to combustibles must be maintained from vehicles parked below the heater.

When installed over hoists, the minimum required safe distances to combustible must be maintained from the uppermost point of the combustible materials placed on the hoist.

Hazardous Locations

Where there is the possibility of exposure to combustible airborne material or vapor, consult the local Fire Marshal, the Fire Insurance Carrier or other authorities for approval of the proposed installation.

Section 3 INSTALLATION

⚠ WARNING

Several steps are involved in the installation of the heater. DO NOT attempt to operate the heater until ALL steps of the installation have been accomplished. Failure to follow this warning will cause death, injury or property damage.

⚠ ATTENTION

Plusieurs étapes sont impliquées dans l'installation de l'appareil de chauffage. PAS la tentative pour opérer l'appareil chauffage jusqu'à ce que TOUTES étapes de l'installation ont été accomplies. L'échec pour suivre cet avertissement causera la mort, les dommages de blessure ou propriété.

Safety Equipment

Use of the following safety equipment is recommended for installation of the MHT tube heater:

- Work gloves
- Safety glasses

Installation Tools

Tools required for the installation of the MHT tube heater include at a minimum the following:

- Tape measure
- Electric drill (with an assortment of drill bits)
- Pipe wrenches – 2 required
- Screwdriver
- Tin snips
- Hacksaw
- Wire strippers
- Staple gun
- Level
- Pliers

Installation Materials

Materials required for the installation of the MHT tube heater include at a minimum the following:

- High temperature silicone sealant
- Suspension hooks (capable of supporting 150 pounds each)
- Sheetmetal screws

The following items may be required for your particular installation:

- Plastic drain hose
- Additional vent pipe
- Roof flashing
- Rain collar
- Chain – 2/0, or equivalent
- S-hooks (as required)

Choose Location for Heater

When selecting a suitable mounting location for the MHT tube heater it is important to consider the following:

1. The heater must meet the minimum mounting height requirement of 7 feet above the floor. For aircraft hangars and public garages, the heater must meet the minimum mounting height requirement of 8 feet above the floor.
2. The proposed mounting location allows for the minimum required safe distances from combustibles (combustibles include vehicles, wood gasoline and flammable objects, liquids and vapors)
3. The proposed mounting location of the heater will not restrict motion of passageway doors or windows.
4. The proposed location will not interfere with operation of the overhead garage door.
5. The proposed location will provide the best coverage of the total area to be heated.
6. The proposed location must provide for adequate combustion and ventilation air.
7. The proposed location must provide for adequate accessibility clearance for service and proper operation.
8. Consideration be given to the types of vehicles that will be parked in the garage (cars, vans, boats, RV's etc.).
9. The proposed location will allow for the minimum required safe distances from combustibles with respect to the vehicles parked in the garage.
10. The proposed location will allow the required utilities (i.e.: gas and electric) and venting to be installed (maximum vent length is 25 feet).
11. Sufficient clearances will exist to allow for maintenance.
12. Overhead structural members (rafters, beams, etc.) are accessible for attaching the heater.
13. Location must allow for adequate clearance around air openings into the combustion chamber.

General Guidelines (Residential)

Regardless of the venting arrangement that will be connected to the heater, the following general guidelines for venting must be followed:

1. The installation must conform with local codes or in the absence of local codes with the *National Fuel Gas Codes, ANSI Z223.1/NFPA 54, Natural Gas and Propane Installation Code, CSA B149.1 for Canada*.
2. Appliance input ratings are based on sea level operation and need not be changed for operating up to 2,000 feet (609.9m) elevation. For operation at elevations above 2,000 feet (609.9m) manufactured to specified deration condition for Canada and the United States.
3. The appliance and its appliance main gas valve must be disconnected from the gas supply piping system during any pressure testing of that system at test pressures in excess of ½ psi. (3.5kPa.).

The appliance must be isolated from the gas piping system by closing equipment shutoff valve during pressure testing of the gas supply piping system at test pressures equal to or less than ½ psi. (3.5kPa.).

(WARNING) Materials and items, when stored under this heater, will be subjected to radiant heat and could be seriously damaged.

4. All horizontal venting sections must slope away from the heater at a rate of ¼" per foot.
5. The total length of vent pipe (horizontal and vertical runs combined, plus the length of the exterior termination) must not exceed 25 feet, and must not be less than 5 feet.
6. The vent terminal, mounted outside of the building, should not be located above walkways. Condensate produced during operation of the heater could drip onto the walkway and could form ice during cold weather.
7. Be sure that the venting installation is in accordance with all applicable local codes and recommendations of the local gas company.
8. **DO NOT** connect this heater to a separate chimney, and **DO NOT** common vent with any other fuel burning appliance. Gas appliances must not be connected to a chimney flue serving a separate solid-fuel burning appliance.
9. Maintain a minimum of 1-inch clearance from combustibles around all vent pipes.
10. Seal all vent pipe connections with high temperature silicone sealant and secure each connection with three sheet metal screws.

Minimum Required Safe Distances from Combustibles

In all situations, the minimum required safe distances from combustibles must be maintained. Combustibles are materials which may catch on fire and include many common items such as wood, paper, rubber, fabrics, etc. Combustible materials such as those noted, and any other combustible materials must not be placed closer to any base or side of the MHT tube heater than the distances noted in the diagrams on the following page. If you have any questions about the minimum required safe distances from combustibles, or the associated diagrams, please contact your installer, Enerco representative or distributor, of Enerco Technical Products during normal business hours which are Monday through Friday, 8:15 a.m. to 4:45 p.m., Eastern Time.

Telephone: (800) 251-0001 or (216) 916-3000

It is important to keep the minimum required safe distances from combustibles at all times to avoid death, personal injury or property

damage. Clearances from vehicles parked beneath heaters must be maintained. Signs should be posted to identify any possible violation of the clearance distances from the heater in the vehicle areas. Maximum allowable stacking height in storage areas should be identified with signs or appropriate markings. The illustrations and Table on the adjoining page specify the minimum required safe distances from combustibles.

Horizontal Installations

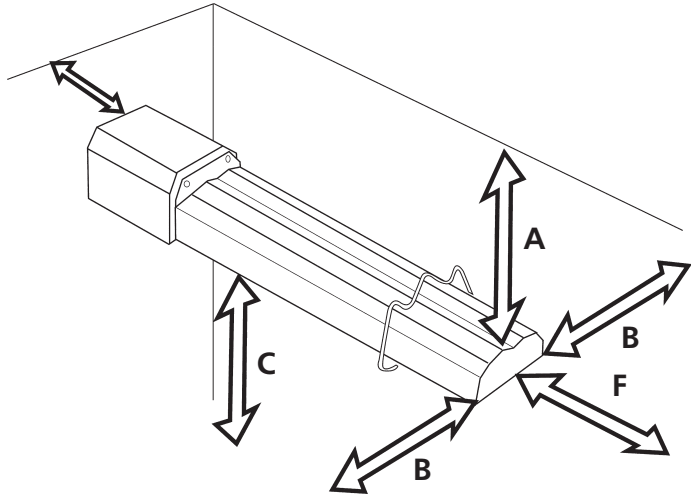

Note: Dimension "C" indicates the minimum required safe distances from combustibles, it **DOES NOT** indicate the required mounting height. The minimum mounting height is 7 feet, except for aircraft hangars and public garages.

45° Tilted Installations

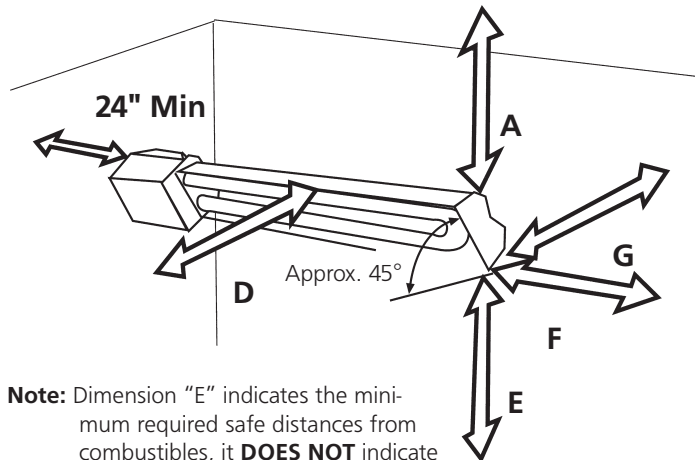

Note: Dimension "E" indicates the minimum required safe distances from combustibles, it **DOES NOT** indicate the required mounting height. The minimum mounting height is 7 feet, except for aircraft hangars and public garages.

MINIMUM REQUIRED SAFE DISTANCES								
Model	BTU/Hr	A	B	C	D	E	F	G
MHT-45	45,000	5"	24"	54"	38"	36"	6"	4"

Hang the Heater

Residential garages come in a variety of sizes, shapes, styles and methods of construction. Because of all these variables, it is not possible to include mounting hardware with the Mr. Heater MHT heater. Although wooden rafters and joists are the most common overhead structural members in residential garage applications, other structural configurations are also illustrated below.

In the typical suspension methods shown below, lengths of chain are shown as a means of lowering the heater. However, for most residential applications it may not be necessary to lower the heater. Instead, it may be possible to screw hook-type hardware into the underside of a beam. The exposed hook could directly engage one of the two mounting holes in the front fixed hanger, while another hook could engage in one of the three suspension loops of the rear moveable hanger.

Whichever method of suspension is selected, the two required **suspension points must be capable of supporting a minimum of 150 pounds each.**

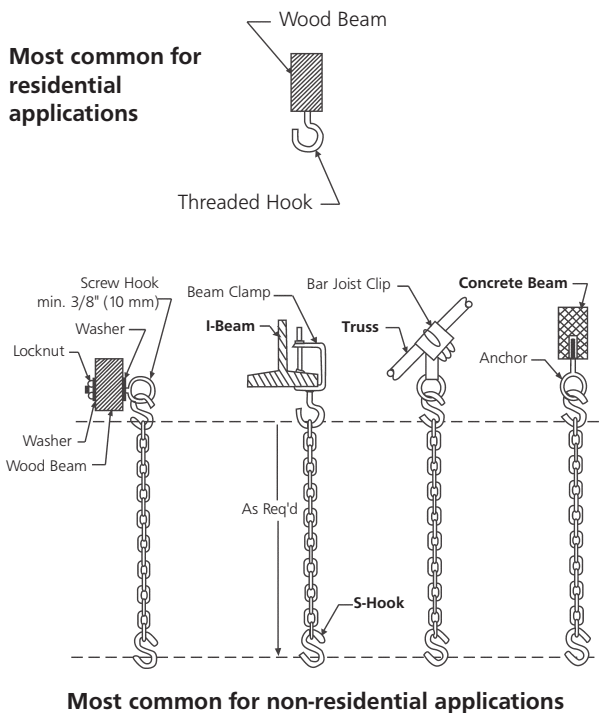

Heater Orientation

The MHT tube heater may be installed in any of the three orientations indicated below. Select the heater orientation that is best suited for the location that you have chosen for your heater.

- Horizontally
- Tilted 45° Right
- Tilted 45° Left

NOTE: If the heater is going to be vented through the roof, be sure to carefully review the roof option installation portion of this section. Ensure that the selected mounting site will satisfy the measurement parameters (vent length not to exceed 25 feet) described in that section. Horizontal Installation

Horizontal Installation

1. Using S-hooks, attach two equal lengths of 2/0 chain, or equivalent, to the two uppermost holes in the front fixed hanger.
2. Slip the free end of both chains onto another S-hook, as shown.
3. The uppermost S-hook can now be installed on the suspension hardware that you have installed for suspension of the unit. An additional length of chain may also now be installed, if required, to lower the heater.

NOTE: The hook portion of hook-type suspension hardware may directly engage the two holes in the front fixed hanger and the center loop of the rear moveable hanger.

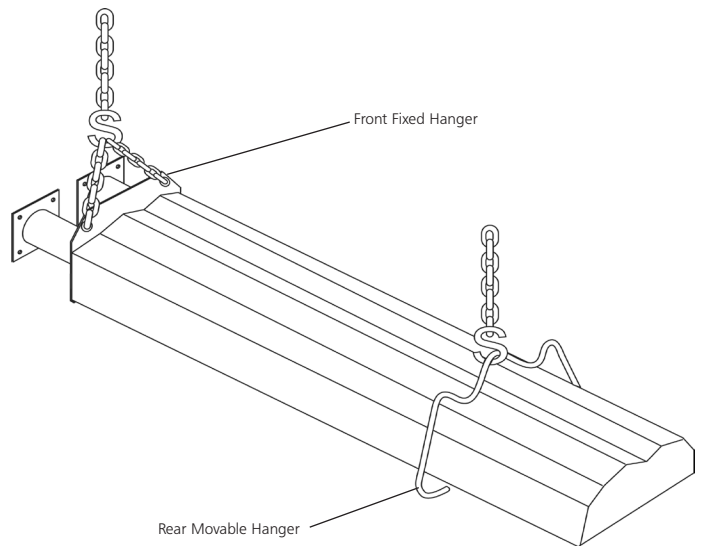

45° Tilted Installation

1. Determine if the heater is going to be tilted left, or tilted right. The front and rear suspension points selected must be on the same side (left or right) of the heater as shown below.
2. Attach suspension hooks and/or chains to the selected suspension points of the heater.

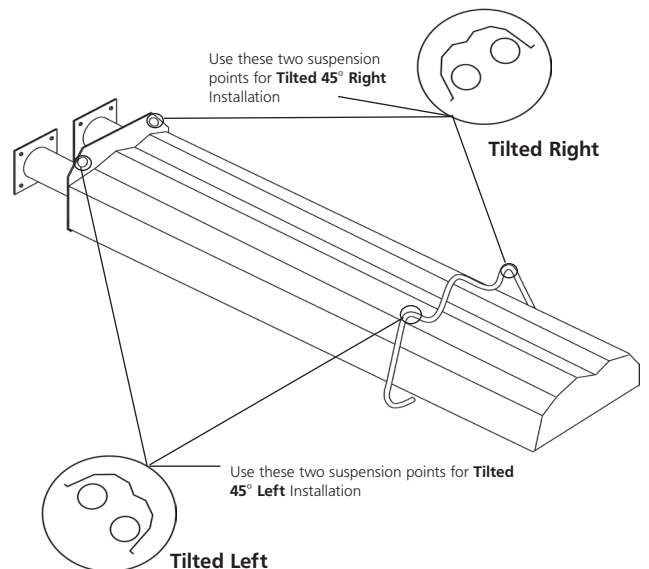

MHT HEATER ASSEMBLY INSTRUCTIONS

1. Place gaskets from Gasket kit (02885) on each side of the burner box. Use the four mounting studs around each of the three-inch holes for location.
2. Slide the tube flanges over the studs as was done in the prior step with the gaskets. The tube ends extend through the flanges to help with alignment.
3. Using the four long and four short nuts from the bolt kit (02876) secure the tube set to the burner box. As shown in the diagram, use the four long nuts in the center and the four short nuts on the outside.
4. Slide the bulkhead and reflector assembly forward until it stops on the long nuts. Using the (4) 5/16-18 X 1/2" long screws from the (02876) bolt kit secure the bulkhead to the burner box.

USE CAUTION AS NOT TO OVERTIGHTEN ASSEMBLY AS IT MAY CAUSE DAMAGE TO PARTS OF ASSEMBLY

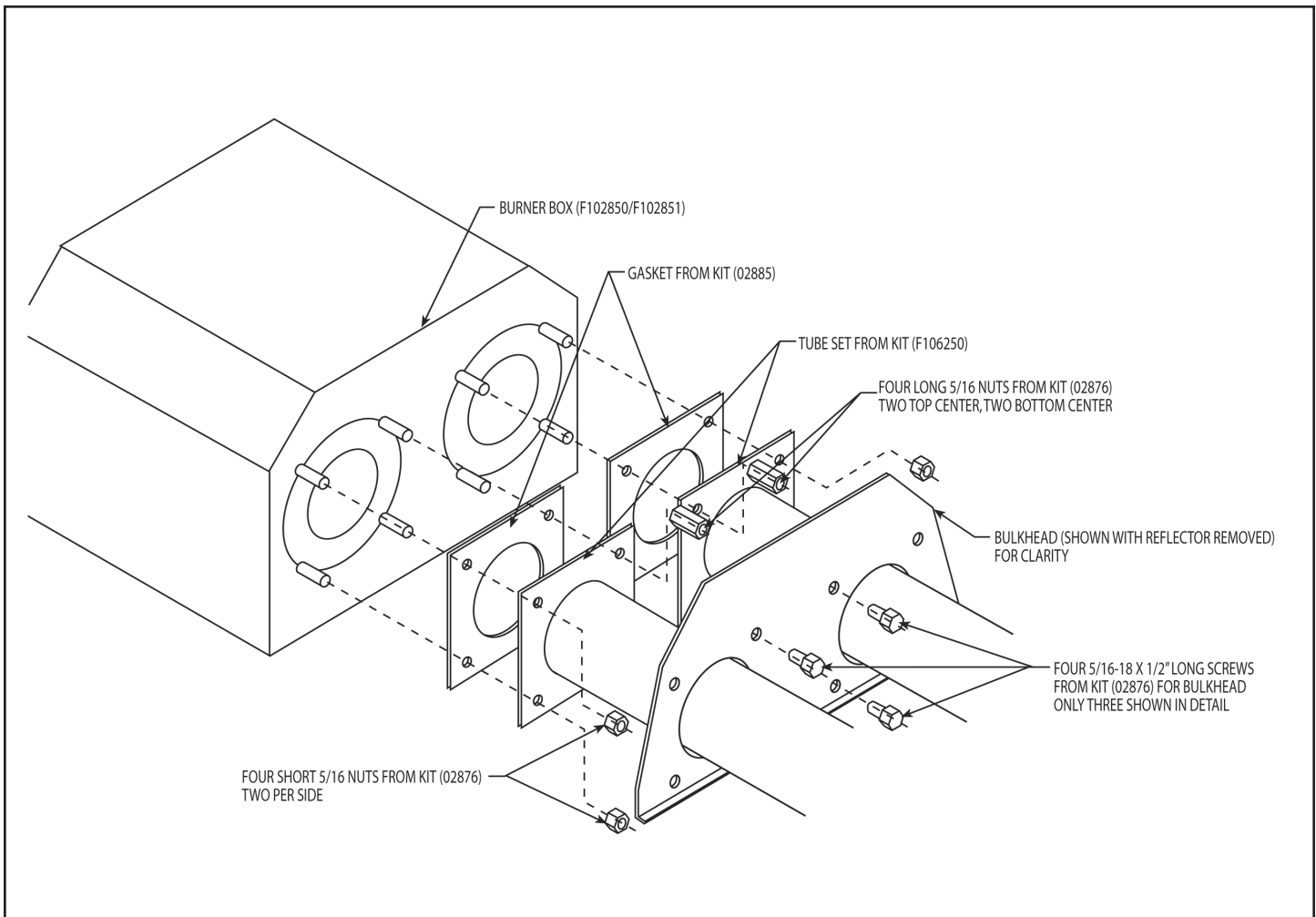

Typical Installation

The illustration below shows a typical installation of the MHT tube heater. The installation drawing shown has a straight horizontal venting arrangement and specifies the minimum space required for maintenance, as well as the allowable range of distances between the two suspension points.

Detailed venting arrangements are illustrated in following portions of this section.

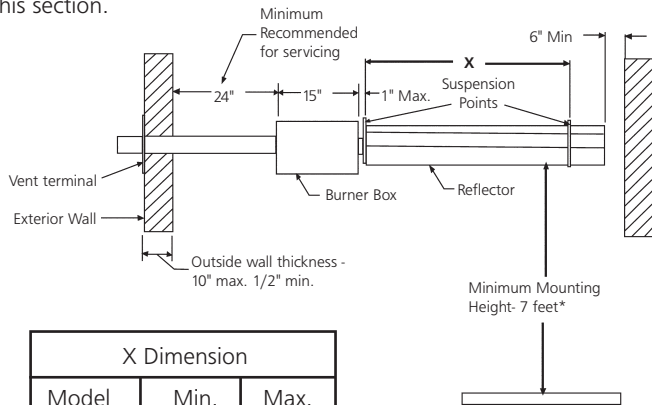

X Dimension		
Model	Min.	Max.
MHT-45	102"	114"

(*) For minimum mounting height in aircraft hangars and public garages.

Section 4 VENTING

This appliance is certified under the ANS/CSA Standard for Vented Gas-Fired Space Heating Appliances. In accordance with these standards all sidewall venting must conform to the supplied diagram for Vent Terminal Clearances, which are stated for both U.S. and Canadian installations. These clearances should be compared to but not less than those specified in the current ANSI Z223.1/ NFPA 54, National Fuel Gas Code, or CSA B149.1, Natural Gas and Propane Installation Code. Clearances not covered in the table or above listed codes must comply with local installation codes and the requirements of your local gas supplier.

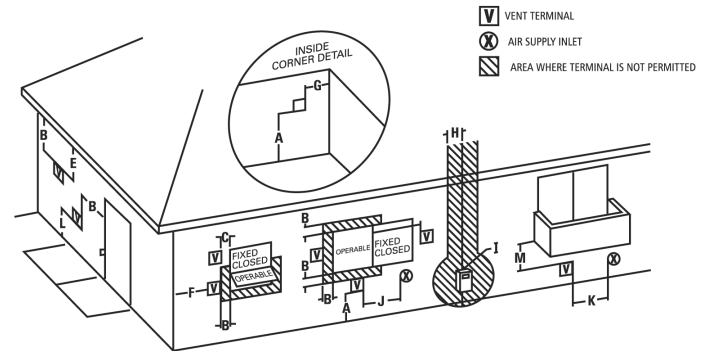

	Canadian Installations ¹	US Installations ²
A= Clearance above grade, veranda, porch, deck or balcony	12 inches (30 cm)	12 inches (30 cm)
B= Clearance to window or door that may be opened	6 inches (15 cm) for appliances ≤ 10,000 Btuh (3 kW), 12 inches (30 cm) for appliances > 10,000 Btuh (3 kW) and ≤ 100,000 Btuh (30 kW), 36 inches (91 cm) for appliances > 100,000 Btuh (30 kW)	6 inches (15 cm) for appliances ≤ 10,000 Btuh (3 kW), 9 inches (23 cm) for appliances > 10,000 Btuh (3 kW) and ≤ 50,000 Btuh (15 kW), 12 inches (30 cm) for appliances > 50,000 Btuh (15 kW)
C= Clearance to permanently closed window	*	*
D= Vertical clearance to ventilated soffit located above the terminal within a horizontal distance of 2 feet (61 cm) from the center line of the terminal	*	*
E= Clearance to unventilated soffit	*	*
F= Clearance to outside corner	*	*
G= Clearance to inside corner	*	*
H= Clearance to each side of center line extended above meter/regulator assembly	3 feet (91 cm) within a height 15 feet (4.5 m) above the meter/regulator assembly	*
I= Clearance to service regulator vent outlet	3 feet (91 cm)	*
J= Clearance to nonmechanical air supply inlet to building or the combustion air inlet to any other appliance	6 inches (15 cm) for appliances ≤ 10,000 Btuh (3 kW), 12 inches (30 cm) for appliances > 10,000 Btuh (3 kW) and ≤ 100,000 Btuh (30 kW), 36 inches (91 cm) for appliances > 100,000 Btuh (30 kW)	6 inches (15 cm) for appliances ≤ 10,000 Btuh (3 kW), 9 inches (23 cm) for appliances > 10,000 Btuh (3 kW) and ≤ 50,000 Btuh (15 kW), 12 inches (30 cm) for appliances > 50,000 Btuh (15 kW)
K= Clearance to a mechanical air supply inlet	6 feet (1.83 m)	3 feet (91 cm) above if within 10 feet (3 m) horizontally
L= Clearance above paved sidewalk or paved driveway located on public property	7 feet (2.13 m) †	*
M= Clearance under veranda, porch deck, or balcony	12 inches (30 cm) ††	*
1	In accordance with the current CSA B149.1, Natural Gas and Propane Installation Code.	
2	In accordance with the current ANSI Z223.1/NFPA 54, National Fuel Gas Code.	
†	A vent shall not terminate directly above a sidewalk or paved driveway that is located between two single family dwellings and serves both dwellings.	
††	Permitted only if veranda, porch, deck, or balcony is fully open on a minimum of two sides beneath the floor.	
*	For clearances not specified in ANSI Z223.1/NFPA 54 or CSA B149.1, one of the following shall be indicated: a) A minimum clearance value determined by testing in accordance with section 2.19.6, or; b) A reference to the following footnote: "Clearance in accordance with local installation codes and the requirements of the gas supplier."	

BASIC FLUE VENTING (Residential Only)

- Venting must be in compliance with the latest edition of the National Fuel Gas Code (ANSI Z223.1 latest edition: or the authority having jurisdiction).
- Uninsulated single-wall metal pipe shall not be used outdoors in cold climates for venting of these heaters as specified by Section 7.8 of the ANSI Z223.1/NFPA 54 National Fuel Gas Code-latest edition.
- For the installation of a single-wall metal pipe through an exterior combustible wall, refer to the latest edition of the National Fuel Gas Code or the authority having jurisdiction.
- In regions of the country where prevailing winds are consistently higher than 40 mph, it may be necessary to terminate the vent system above the roof level.

Other venting references can be found in equipment volume of the ASHRAE Handbook.

A. SINGLE HEATER VENTING

a) Vertical Through the Roof

NOTE: For residential applications, the heater must not be connected to a separate chimney, but must be installed using the venting system as specified below.

1. When venting the heater to outside of building through a roof, use 3 inch O.D. single-wall metal pipe. This is to be constructed of galvanized sheet metal or other approved noncombustible, corrosion-resistant material as indicated by state and/or local codes.
2. A vent passing through a combustible roof shall extend through a 2-inch clearance roof thimble. Double-wall, Type B vent must be used for the portion of the vent system which passes through the roof. An approved vent cap (such as Leslie "VersaCap" Type B) must be attached to the end of the flue.
3. The maximum equivalent length of vent pipe should be carefully observed. A safety switch in the heater is designed to shut the heater off before excessive flue restriction causes bad combustion.

Minimum Equivalent Length = 5 feet of Pipe

Maximum Equivalent Length = 25 feet of Pipe

Use the following correction factors to obtain the equivalent length:

- a) Subtract 15 feet if the run is horizontal.
 - b) Subtract 10 feet for an approved vent cap.
 - c) Subtract 10 feet for each elbow beyond 15 feet from the heater.
 - d) Subtract 15 feet for each elbow within 15 feet of the heater.
4. Limit the quantity of 90° elbows to two. When vent pipe is in a horizontal run, it must rise not less than ¼ inch per foot from the start of the vent system towards the vent terminal.
 5. Joints between sections of piping shall be fastened by sheet metal screws or other approved means.

The seams along the length of the piping and the joints between sections of piping should be sealed to prevent a potential leakage of flue gas into building. Use 100% RTV Silicone Rubber Adhesive sealant suitable for 500°F.

6. All portions of the vent pipe shall be supported to prevent from sagging.
7. When the vent pipe passes through areas where the ambient temperature is likely to induce condensation of the flue gasses, the vent pipe should be insulated and a condensation drain should be provided.
8. The minimum clearance to combustible materials for single-wall flue pipe shall be 6 inches. This may be reduced when the combustible material is protected as specified in the National Fuel Gas Code or the authority having jurisdiction.
9. Single-wall metal pipe shall not originate in any unoccupied attic or concealed space and shall not pass through any attic, inside wall or concealed space, or through any floor.
10. A venting system shall terminate at least 3 feet (0.9m) above any forced air inlet located within 10 feet (3.1m).

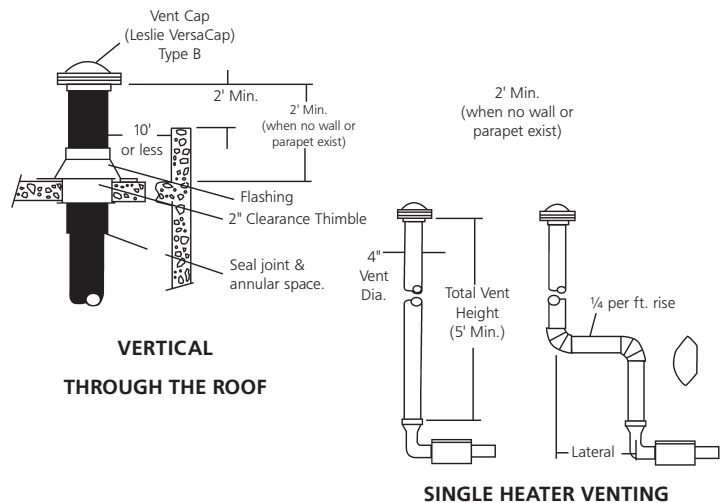

b) Vent Termination (Residential Installations)

1. The vent terminal shall terminate above the roof line so that no discharge opening is less than 2 feet (0.6m) horizontally from the roof surface. The lowest discharge opening will be no closer than the minimum height specified in the following table. These minimum heights may be used provided the vent is not less than 8 feet (2.4m) from any vertical wall or similar obstruction.

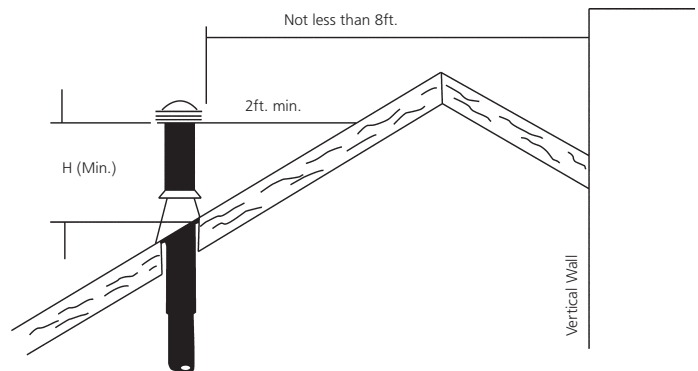

- a) Be sure that method selected for venting heater complies with all

MINIMUM HEIGHT FROM ROOF TO LOWEST DISCHARGE OPENING		H (Min)
Roof Pitch		
Flat	to 6/12	1.0 Feet
Over 6/12	to 8/12	1.5 Feet
Over 8/12	to 10/12	2.5 Feet
Over 10/12	to 12/12	4.0 Feet
Over 12/12	to 16/12	6.0 Feet
Over 16/12	to 20/12	7.5 Feet

2. All other gas vents shall terminate not less than 2 feet (0.6m) above the highest point where they pass through the roof and at least 2 feet (0.6m) higher than any portion of a building located within 10 feet (3.1m) as shown in the following illustration.

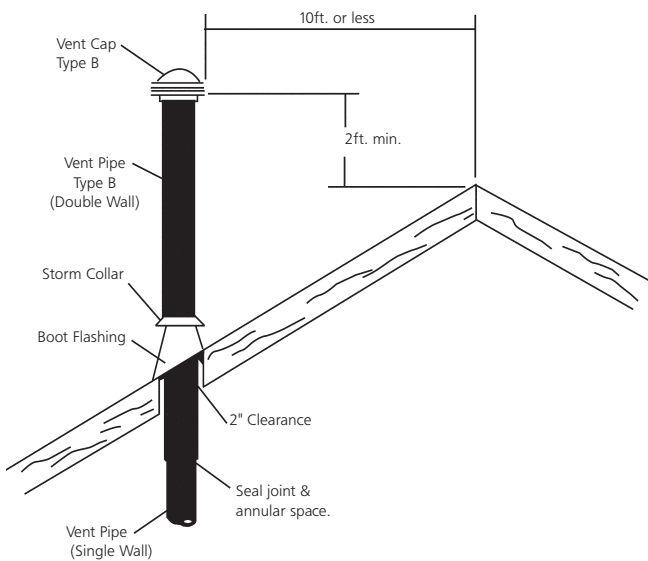

c) Horizontal Through the Sidewall

This heater, when horizontally vented, must be installed with the approved venting system.

When venting the heater horizontally through a combustible outside wall, the same requirements listed previously for Venting **Through the Roof** apply except as follows:

- When venting the heater to the outside of the building through a sidewall, use 3 inch O.D. single-wall metal pipe. This is to be constructed of galvanized sheet metal or other approved noncombustible, corrosion-resistant material as indicated by state and/or local codes.
- For horizontal venting, the vent lengths may be as follows:
 - Minimum Equivalent Length = 5 feet of Pipe
 - Maximum Equivalent Length = 25 feet of Pipe
 Use the following correction factors to obtain the equivalent length:
 - Subtract 15 feet if the run is horizontal
 - Subtract 10 feet for an approved vent cap.
 - Subtract 10 feet for each elbow beyond 15 feet from the heater.
 - Subtract 15 feet for each elbow within 15 feet of the heater.

NOTE: To minimize problems associated with condensation in long runs, vent pipe can be insulated.

- The horizontal venting system approved with this heater consists of the Side Wall Vent Kit (02840) shown on page 3.
- Limit the quantity of 90° elbows to two. When vent pipe is in a horizontal run, it must be pitched downward ¼ inch per foot towards the vent terminal. The heater must be installed level.
- The horizontal venting system shall not terminate:
 - Less than 4 feet (1.2m) below, 4 feet (1.2m) horizontally from, or 1 foot (30cm) above any door, window or gravity air inlet into any building. The bottom of the vent terminal shall be located at least 7 feet (2.1m) above grade or above snow accumulation levels as determined by local codes.
 - Less than 3 feet (0.9m) from a combustion air inlet.
 - Less than 3 feet (0.9m) from any other building opening or any gas service regulator.
 - Directly over areas where condensate or vapor could create a nuisance or hazard or be harmful to the operation of gas utility meters, regulators, relief valves, or other equipment. Building materials should be protected from flue gases and condensate.
- In regions of the country where prevailing winds are consistently higher than 40 mph, it may be necessary to terminate the vent system above the roof level.

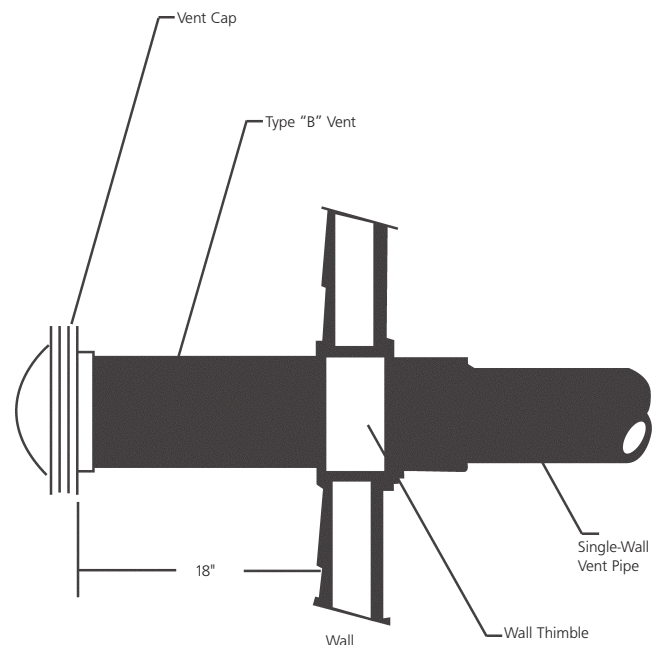

Venting/Ducting For Commercial and Industrial Installations Only

General Requirements

Use aluminum or teflon tape suitable for 550°F (3M Company tapes #433 or #363) or RTV silicone sealant.

Heater must be vented in accordance with specification ANSI Z223.1 - latest revision. Partial information relating to this specification is provided in this section with regard to size and configurations for venting arrangements. For complete information consult ANSI Z223.1 - latest revision and applicable local codes. Use the following guidelines to help insure an adequate, safe venting arrangement.

codes as required for each particular location.

- b) Exhaust end of heater will accept a three (3") inch flue pipe using the flue pipe adapter.
- c) Heater may be vented to the outdoors either vertically or horizontally.
- d) *If heater is to be vented horizontally:*
 - 1) Vent must exit building not less than seven (7') feet above grade when located adjacent to public walkways.
 - 2) Vent must terminate at least three (3') feet above any forced air inlet located within ten feet (10').
 - 3) Vent must terminate at least four (4') feet below, for (4') feet horizontally from, or one (1') foot above any door, window, or gravity inlet into any building.
 - 4) Vent terminal shall be located at least twelve (12") inches from any opening through which vent gases could enter the building.
- e) Vent terminal opening must be beyond any combustible overhang.
- f) If condensation in the flue is a problem, the flue length should be shortened or insulated.
- g) For vent specifications all of the following conditions must be met:

The maximum equivalent length of vent pipe should be carefully observed. A safety switch in the heater is designed to shut the heater off before excessive flue restriction causes bad combustion.

Minimum Equivalent Length = 5 feet of Pipe

Maximum Equivalent Length = 25 feet of Pipe

Use the following correction factors to obtain the equivalent length:

- 1) Subtract 15 feet if the run is horizontal.
- 2) Subtract 10 feet for an approved vent cap.
- 3) Subtract 10 feet for each elbow beyond 15 feet from the heater.
- 4) Subtract 15 feet for each elbow within 15 feet of the heater.

Limit the quantity of 90° elbows to two. When vent pipe is in a horizontal run, it must rise not less than 1/4 inch per foot from the start of the vent system towards the vent terminal.

Alternative Arrangements /Optional Equipment for Venting

Horizontal Venting

- a) In combustible or noncombustible walls, use vent kits on page (3). Follow vent manufacturer's instructions for proper installation.
- b) Three (3") inch O.D. flue pipe is required. Twenty five (25') feet maximum length is recommended.
- c) All flue joints should be sealed using suitable product such as General Electric RTV 106 or Permatex Form-A-Gasket Red High Temperature Silicone Adhesive Sealant.
- d) Vent terminal should be installed at a height sufficient to prevent blockage by snow.
- e) Building materials should be protected from degradation by flue gases.

Single Wall

Single wall vent run
Single wall terminal end

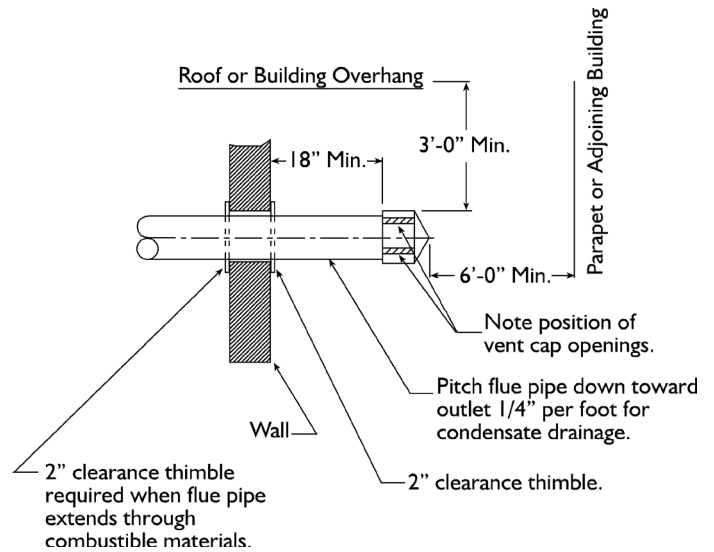

Double Wall

Double wall vent run and
Double wall terminal end

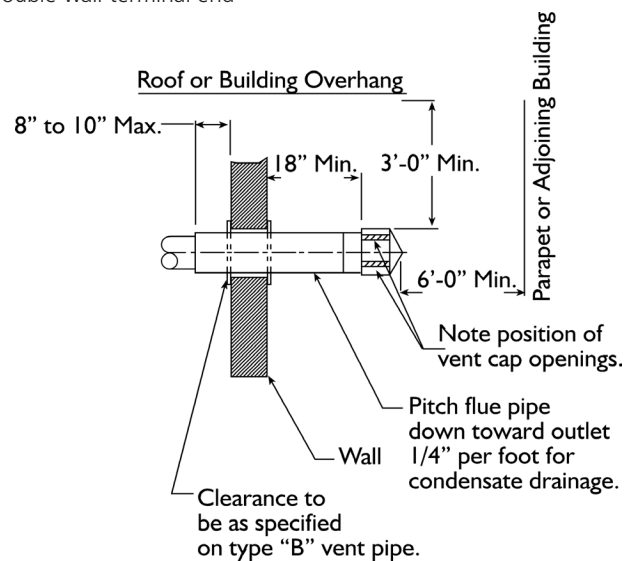

Vertical Venting

- a) Three (3") inch O.D. flue pipe, maximum twenty five (25') feet in length may be used as shown with approved vent cap.
- b) An insulated thimble may be required to pass through combustible structures (check local codes).
- c) All flue joints should be sealed using suitable products (see recommendation for horizontal venting).

Vertical Venting

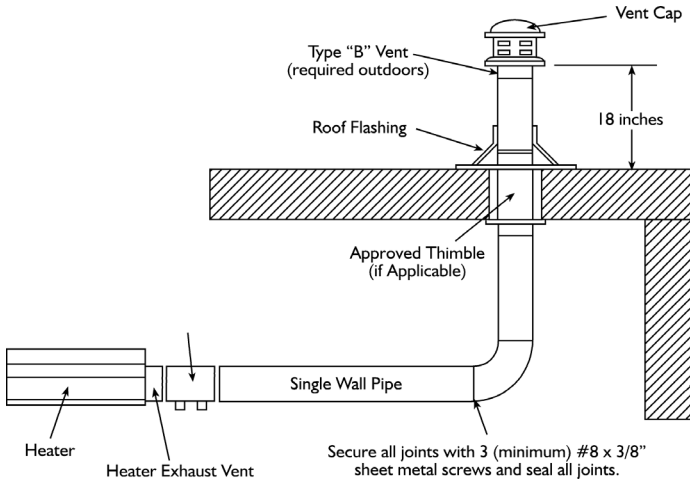

Air For Combustion (Residential)

If indoor combustion air is to be supplied for a tightly enclosed area, one square inch of free area opening shall be provided below the heater for each 1,000 Btu/hr of heater input.

When outside air is used, the opening below the heater shall be one square inch of free area for each 4,000 Btu/hr of heater input. In contaminated atmospheres or high humidity areas, optional outside air for combustion is recommended.

Adequate clearances around the perforated fresh air plate must be maintained at all times. In larger open areas of buildings, infiltration normally is adequate to provide air for combustion.

Direct Outside Air For Combustion (Residential)

Outside combustion air should be supplied directly to the heater when the building is subject to negative pressure or contaminants are present in the building air. These contaminants include paints, solvents, corrosive vapors or any other foreign particles that may cause damage to the heater or result in poor combustion.

Outside combustion air can be brought directly to the heater by a 3 inch diameter duct less than 25 feet long or equivalent. This is attached to a 3 inch starting collar that is fitted on inlet side of the control cabinet. An approved vent cap must be placed directly to the end of the outside combustion air inlet pipe. The combustion air inlet should be a minimum of 3 feet, either vertically or horizontally, from the flue vent termination. The air intake terminal must be located not less than one foot above grade. It is good installation practice to supply combustion air from the same pressure zone as the vent outlet.

In colder climates, where necessary, insulate the fresh air duct. Avoid locating the fresh air duct directly above the control box. Provide a capped cleanout T as necessary.

VERTICAL THROUGH THE ROOF

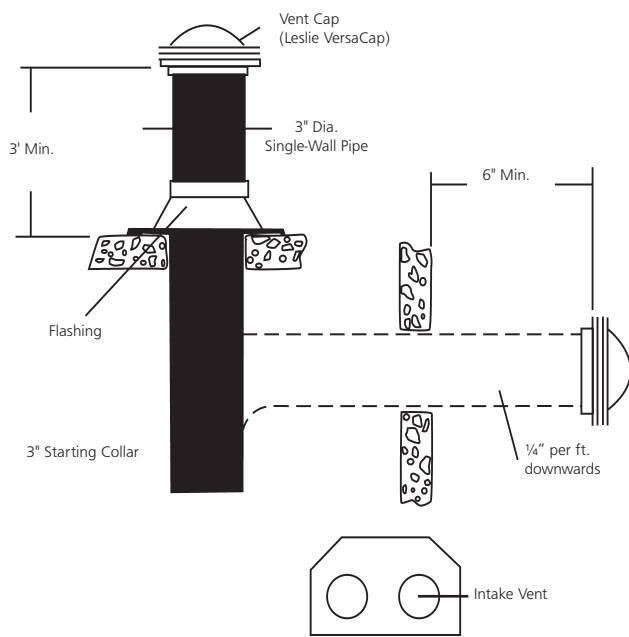

Outside Combustion Air Supply

The MHT tube heater is approved for installation with an outside air supply system. Some compounds such as halogenated hydrocarbons or other corrosive chemicals in the air can be drawn into the equipment and cause an accelerated rate of corrosion of some of the heater components. The use of such chemical compounds near the enclosure should be avoided.

IMPORTANT: If the building has a slight negative pressure or contaminants are present in the air, an outside combustion air supply to the heaters is strongly recommended.

For an outside air supply a three (3") inch O.D. single wall pipe may be attached to the heater. The duct may be up to twenty five (25') feet maximum length or two (2') feet minimum length with no more than two (2) elbows.

The air supply duct may have to be insulated to prevent condensation on the outer surface. The outside air terminal should be securely fastened to the outside wall by drilling four (4) holes in the outside flange; wood screws or bolts and expansion sleeves may be used to fasten terminal.

Non-Pressurized Outside Air Supply Duct

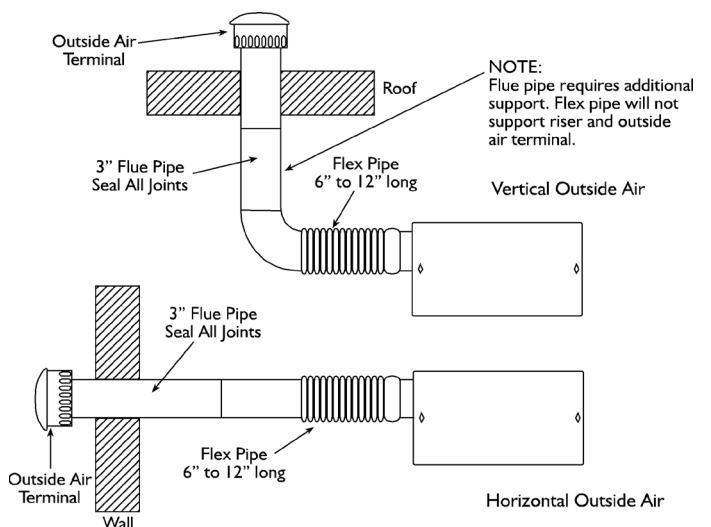

Electrical Service Installation: System Requirements

The MHT tube heater requires a grounded three-prong electrical outlet to be installed within 18" of the rear surface of the heater's burner box. It is recommended that the outlet for the heater be ceiling-mounted and should be on a dedicated circuit. **DO NOT** use an electrical extension cord to operate the heater.

In order to control the heater thermostatically, it is necessary that the grounded three-prong electrical outlet be controlled with a on/off switch or a line voltage thermostat. Please consult with an electrician or follow all local electrical codes.

Heater Rating: 120 VAC, 60Hz, Single Phase, 1 Amp

CAUTION Label all wires prior to disconnection when servicing controls. wiring errors can cause improper and dangerous operation. Verify proper operation after servicing.

Grounding

The heater must be electrically grounded in accordance with the following codes: United States: Refer to National Electrical Code, ANSI/NFPA-70 – latest revision. Wiring must conform to the most current National Electrical Code and local ordinances. Canada: Refer to Canadian Electrical Code, CSA C22.1 Part 1– latest revision.

LADDER DIAGRAM

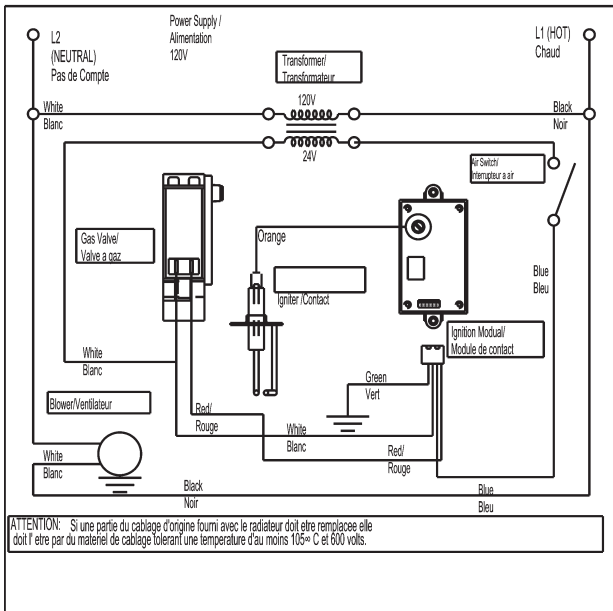

CONNECTION DIAGRAM

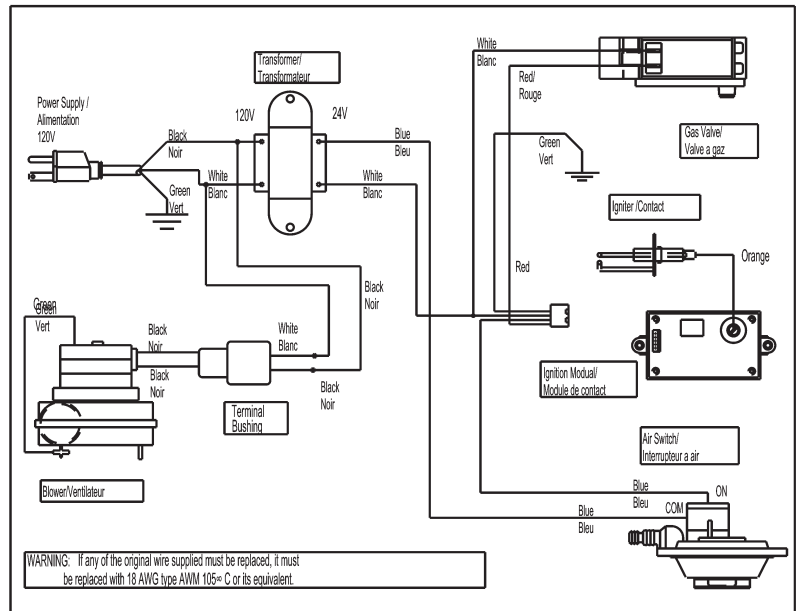

PIN-02829

⚠ WARNING Electrical Shock Hazard
 Plug heater into grounded three prong ceiling receptacle. Do not cut or remove the grounding prong from this plug. Do not use with an extension cord. Failure to follow these instructions will result in death or electrical shock.

⚠ ATTENTION Risque d'électrocution
 Brancher le cordon du radiateur sur un socle à 3 broches et à la masse, situé au plafond. Ne pas sectionner ou retirer la broche de masse de cette prise. N'utiliser aucun câble de rallonge. Le non-respect de ces consignes peut entraîner mort ou électrocution.

<p>⚠ ATTENTION ⚠</p> <p>L'Instruction Mettre a Electrique Cet appareil de chauffage est équipé avec une tris (mettre a terre) le bouchon pour votre protection contre le danger de choc et devrait être directement plugged dans un convenablement a mis a terre receptacle de tris broche. N' pas couper ou enlever la broche mettre a terre de ce bouchon.</p>		<p>⚠ WARNING ⚠</p> <p>Electrical Grounding Instructions This heater is equipped with a three-prong (grounded) plug for your protection against shock hazard and should be plugged directly into a properly grounded three-prong receptacle. Do not cut or remove the grounding prong from this plug.</p>
--	--	--

The appliance, when installed, must be electrically grounded in accordance with local code, or in the absence of local codes, with the *National Electrical Code (ANSI/NFPA 70)* or *Canadian Electrical Code (CSA 22.1)*, if an external electrical source is utilized.

Gas Service Installation

Install Gas Supply Lines

A 1/2" gas supply connection is required as shown below. To check system pressure, a plugged 1/8" NPT tapping is required upstream of the manual gas shut-off valve supplied with the heater.

Before connecting the heater to the supply system, verify that all high pressure testing of the gas piping has been completed.

DO NOT HIGH PRESSURE TEST THE GAS PIPING WITH THE BURNER CONNECTED.

Follow these instructions to ensure a safe gas supply system installation:

1. Support all gas piping with suitable pipe hanging materials.
2. Use wrought iron or wrought steel pipe and malleable iron fittings. The use of copper tube and brass fittings is acceptable

when such use is in compliance with local codes. All pipe, tube and fittings should be new and free from defects. Carefully ream the pipe and tube ends to remove obstructions and burrs.

- Use LP-resistant joint compound on all threads.
- Check the pipe and tube connections for leaks before placing heating equipment into service. When checking for gas leaks, use a soap and water solution; never use an open flame.

NOTE: A plugged 1/8" NPT tapping must be provided upstream of the gas supply to the heater. The gas supply line connecting to the heater appliance should be such that it allows for some movement of the unit. The appliance will go through expansion and contraction during a heating cycle.

Supplied by others

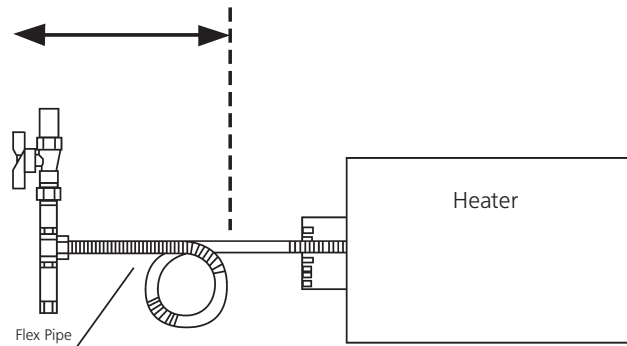

Section 5 OPERATION

⚠ WARNING	
WARNING: If you do not follow these instructions exactly, a fire or explosion may result causing property damage, personal injury or loss of life.	
SAFETY INSTRUCTIONS READ BEFORE OPERATION	OPERATING INSTRUCTIONS
<p>A. This appliance does not have a pilot. It is equipped with an ignition device which automatically lights the burner. DO NOT try to light the burner by hand.</p> <p>B. BEFORE OPERATING smell all around the appliance area for gas. Be sure to smell next to the floor because some gas is heavier than air and will settle on the floor.</p> <p>WHAT TO DO IF YOU SMELL GAS</p> <ul style="list-style-type: none"> *Do Not try to light any appliance. *Do Not touch any electrical switch; do not use any phone in your building. *Immediately call your gas supplier from a neighbor's phone. Follow gas supplier's instructions. *If you cannot reach your gas supplier, call the fire department. <p>C. Use only your hand to turn the gas valve handle. Never use tools. If handle will not turn by hand, do not try to repair it, call a qualified service technician. Force or attempted repair may result in a fire or explosion.</p> <p>D. Do not use this heater if any part has been under water. Immediately call a qualified service technician to inspect the heater and replace any part of the control system which has been under water.</p> <p>E. Minimum clearances to other materials or other items which, when located under the heater, might be damaged due to excessive heat.</p>	<p>1. STOP! Read the safety instructions on this label.</p> <p>2. Set the thermostat to lowest setting.</p> <p>3. Turn off all electrical power to appliance.</p> <p>4. This appliance is equipped with an ignition device which automatically lights the burner.</p> <p>5. Remove control access panel.</p> <p>6. Push in gas control knob to unlock.</p> <p style="text-align: center;">NOTE: Valve lever is spring loaded and will drop automatically.</p> <p>7. Wait (5) minutes to clear out any gas. If you then smell gas, STOP! Follow "B" in the safety information to the left of instructions. If you don't smell gas, go to next step.</p> <p>8. Turn gas control knob counterclockwise ↺ to "ON".</p> <p>9. Replace control access panel.</p> <p>10. Turn on all electric power to appliance.</p> <p>11. Set thermostat to desired setting.</p> <p>12. If the heater will not operate, follow the instructions "To Turn Off Gas To Heater" and call your service technician or gas supplier.</p>
⚠ ATTENTION	
ATTENTION: Si vous ne suivez pas ces instructions exactement, un feu ou l'explosion peut resulter, causant les dommages de propriete, la blessure personnelle ou perdu de vie.	
CONSIGNES DE SECURITE A LIRE AVANT UTILISATION	CONSIGNES D'UTILISATION
<p>A. Ce radiateur n'a pas de veilleuse. Il est equipe d'un mecanisme de contact qui allume automatiquement le bruleur. N'ESSAYEZ en aucun cas d'allumer le bruleur avec une allumette.</p> <p>B. AVANT UTILISATION, reperez toute odeur de gaz aux alentours de la zone du radiateur, en particulier pres du sol: certains gaz sont plus lourds que l'air et s'accumulent au niveau du sol. QUE FAIRE SI VOUS SENTEZ DE GAZ</p> <ul style="list-style-type: none"> *Ne pas tenter de mettre le radiateur en marche. *Ne touchez a aucun interrupteur electrique, n'utilisez aucun des telephones de votre batiment. *Appelez immediatement votre fournisseur de gaz depuis le telephone d'un voisin. Suivez les consignes de votre fournisseur. *Si vous ne pouvez pas contacter voter fournisseur, appelez les pompiers. <p>C. Ne tournez la poignee de la valve a gaz qu'a la main. Ne jamais utiliser d'outil. Si la poignee ne tourne pas a la main, n'essayez pas de la reparer: appelez un technicien d'entretien qualifie. Forcer sur la poignee ou tenter une reparation peut produire un incendie ou une explosion.</p> <p>D. N'utilisez pas ce radiateur si une piece quelconque a ete submergee. Appelez immediatement un technicien d'entretien qualifie pour qu'il inspecte le radiateur et remplace toute piece du systeme de commande qui a ete submergee.</p> <p>E. Les degagements minimum aux autres materiels ou aux autres articles qui, quand localise sous l'appareil de chauffage, pourrait etre endommage en raison de la chaleur excessive.</p>	<p>1. L'AARET! Lire les instructions de surete sur cette etiquette.</p> <p>2. Reglent le thermostat a virage.</p> <p>3. Reglage le plus bas de tour pouvoir electrique a l'appareil.</p> <p>4. Cet appareil est equipe avec un appareil d'allumage qui allume automatiquement le bruleur. Ne pas essayer d'allumer le bruleur a la main.</p> <p>5. Eleve le controle panneau d'accès.</p> <p>6. Pousser dans le bouton de controle de gaz.</p> <p style="text-align: center;">NOTE: Le levier de soupape est le resort charge et tombera automatiquement.</p> <p>7. Attendre 5 minutes pour eclaireir hors le gaz de formi, Si vous sentez alors le gaz, L'AARET! Suivre le "B" dans l'information de surete au gauche d'instructions. Si vous sentez pas le gaz allez a l'etape prochaine.</p> <p>8. Le bouton de controle de gaz de virage dans le sen inverse des aiguilles d'une montre ↻ "A SUR".</p> <p>9. Ramplacer le controle panneau d'accès.</p> <p>10. Allume tout pouvoir electrique au appareil.</p> <p>11. Regler le thermostat au reglage desire.</p> <p>12. Si l'appareil de chauffage n'operera pas, suivra les instructions, "Tourner du Gaz A L'Appareil de chauffage" et appele votre fournisseur de d'entretien ou gaz.</p>
TO TURN OFF THE GAS TO HEATER	
<p>1. Set thermostat to lowest setting.</p> <p>2. Turn off all electric power to the appliance if service is to be performed.</p> <p>3. Remove control access panel.</p> <p>4. Push in gas control knob slightly to unlock.</p> <p style="text-align: center;">NOTE: Valve lever is spring loaded and will drop automatically.</p> <p>5. Replace control access panel.</p>	
POUR COUPER L'ALIMENTATION EN GAZ DU RADIATEUR	
<p>1. Reglent le thermostat a virage.</p> <p>2. Reglage le plus bas de tour pouvoir electrique a l'appareil si le service va etre execute.</p> <p>3. Eleve le controle panneau d'accès.</p> <p>4. Pousser dans le bouton de controle de gaz.</p> <p style="text-align: center;">NOTE: Le levier de soupape est le resort charge et tombera automatiquement.</p> <p>5. Ramplacer le controle panneau d'accès.</p>	
ATTENTION:	
L'installation deplace, l'ajustement, le service ou l'entretien peuvent causer les dommages de blessure ou propriete. Se referer au manuel d'iformation du proprietaure fourni avec cet appareil. Pour l'assistance ou d'information, supplementaire, consulter un installateur, une agency de service ou le fournisseur de gaz qualifie.	

Operation of the Heater

CHILDREN AND ADULTS SHOULD BE ALERTED TO THE HAZARDS OF HIGH SURFACE TEMPERATURES AND SHOULD STAY AWAY TO AVOID BURNS OR CLOTHING IGNITION.

YOUNG CHILDREN SHOULD BE CAREFULLY SUPERVISED WHEN THEY ARE IN THE SAME SPACE AS THE HEATER.

CLOTHING OR OTHER FLAMMABLE MATERIALS SHOULD NOT BE HUNG FROM THE HEATER, OR PLACED ON OR NEAR THE HEATER.

ANY GUARD OR OTHER PROTECTIVE DEVICE REMOVED FOR SERVICING THE HEATER MUST BE REPLACED PRIOR TO OPERATING THE HEATER.

INSTALLATION AND REPAIR SHOULD BE DONE BY A QUALIFIED SERVICE PERSON. THE HEATER SHOULD BE INSPECTED BEFORE USE AT LEAST ANNUALLY BY A QUALIFIED SERVICE PERSON. MORE FREQUENT CLEANING MAY BE REQUIRED AS NECESSARY. IT IS IMPERATIVE THAT THE CONTROL COMPARTMENT, AIR PASSAGEWAYS AND BURNER (S) OF THE HEATER ARE KEPT CLEAN.

1. Turn the thermostat up. When the thermostat calls for heat, the blower motor will energize.
2. When the motor approaches nominal running speed, the air proving switch closes and activates the ignition module which in turn initiates the purge.
3. The ignition module then energizes the spark igniter.
4. When sparking begins, the gas valve is energized.
5. If a flame is detected, the gas valve remains open. When the call for heat is satisfied, and the system control mechanism de-energizes, the burner line voltage supply and the gas valve are turned off.
6. If no flame is detected, the gas valve is closed, and a purge period begins. After the purge period, the ignition module energizes the spark igniter and the gas valve. If a flame is still not established, a third and final purge/ignition sequence is begun. After three failed attempts, the system control mechanism will lock out for a period of one hour, or until the unit is reset. Reset is accomplished by removing power from the heater for at least five seconds.
7. With a three-try module, when the flame is established and then lost on the first or second trial, the gas valve will automatically turn off. A purge and trial for ignition will then occur.
8. Periodic visual check of burner flame while unit is in operation through sight glass in bottom of unit.

Section 6 MAINTENANCE

Pre-Season Maintenance

Heater area to be kept clear and free from combustible materials, gasoline and other flammable vapors and liquids.

Do not use this appliance if any part has been under water. Immediately call a qualified service technician to inspect the appliance and replace any part of the control system and any gas control, which has been under water.

(CAUTION) Label all wires prior to disconnection when servicing controls. wiring errors can cause improper and dangerous operation.

For best performance, the following maintenance procedures should be performed by a qualified service agency before each heating season:

1. A qualified service agency should be contacted for service other than routine maintenance.

⚠WARNING Turn off the gas and electrical supplies to the heater before performing any service or maintenance. Failure to observe this warning will cause death, injury or property damage.

⚠ATTENTION le virage du gaz et les provisions électriques à l'appareil de chauffage l'avant d'exécuter service de anr ou l'entretien. L'échec pour observer que cet avertissement causera la mort, les dommages de blessure ou propriété.

2. Check condition of blower scroll and motor. Dirt and dust may be blown out with compressed air, or a vacuum cleaner may be used.
3. Check the condition of the burner cup. Carefully remove any dust or debris from inside burner cup.
4. Inspect the igniter. Replace igniter if there is excessive carbon residue, erosion of electrodes or other defects.
5. Check to see that the burner observation window is clean and free of cracks or holes. Clean or replace as required.
6. Check the flue pipe for soot, dirt or obstructions. The flow of combustion and ventilation air should not be obstructed. After cleaning as necessary, re-attach the flue pipe to the heater.
7. Outside surfaces of heater reflector may be cleaned by wiping with a damp cloth.
8. Check vent terminal and outside air inlet to see that they have not become blocked during the non-heating season. If either pipe is restricted, the air switch won't close, resulting in a no-heat situation.
9. Verify proper operation after service.

Proper Operating Flame

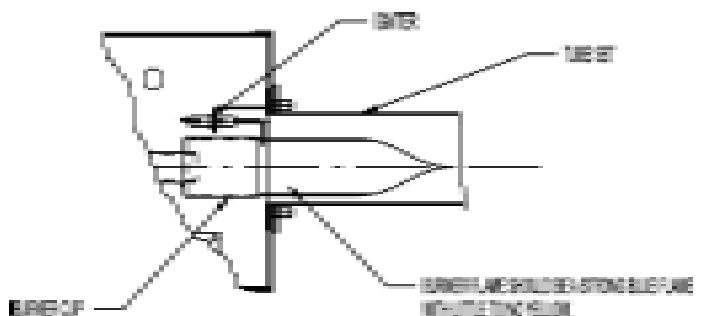

Section 7 TROUBLESHOOTING

General

This troubleshooting guide has been designed to assist you in locating and correcting minor problems that may occur with the MHT tube heater.

BLOWER DOES NOT COME ON	
Possible Cause	Try This....
Power cord is not plugged in.	Plug power cord into a grounded three prong Outlet.
Thermostat setting is too low.	Increase thermostat temperature setting.
DSI module needs to be reset. minimum of five seconds. Plug heater cord back into outlet.	Unplug heater power cord from the electrical Outlet: wait for a
No power at electrical outlet.	Replace fuse or reset circuit breaker
Faulty blower motor	Replace blower motor.

IGNITER DOES NOT SPARK	
Possible Cause	Try This.....
DSI module needs to be reset.	Unplug heater power cord from the electrical outlet: wait for a minimum of five seconds. Plug heater cord back into outlet.
Faulty igniter or ignition wire.	Unplug heater power cord from the electrical outlet; check igniter and ignition wire for damage. If damaged, replace igniter and/or ignition cable.
Air switch does not operate.	Check flue/air supply duct for obstructions; remove obstructions as required. Check for loose/leaky air hoses to the air switch; repair/replace/tighten hoses as required. Check for 24V across the secondary terminals 4 and 5 (red and yellow wires) of the transformer. IF NO: Check for 120V across the primary terminals 1 and 3 (black and white wires) of the transformer. If 120V is present, replace transformer. If 120V is not present, check wiring between power cord, blower motor and transformer. IF YES: Connect a jumper wire across air switch terminals; if jumper wire allows blower to operate, replace pressure switch (see replacement parts list for part number that applies to your unit rating).
Igniter spark gap incorrect.	Reset spark gap to 1/8" (0.125").

BURNER DOES NOT LIGHT	
Possible Cause	Try This....
Air in the gas line.	Purge gas lines.
Improper gas inlet pressure.	<p>Check gas inlet pressure at the 1/8" NPT plugged tap. Gas inlet pressure should be as follows:</p> <p>Natural Gas: 5.0" w.c. min.; 10.5" max.</p> <p>LP Gas: 11" w.c. min.; 13.0" max.</p> <p>If gas inlet pressure does not meet inlet pressure requirements contact the gas company.</p>
Gas valve does not open.	<p>Check for 24V across valve terminals.</p> <p>Check Shutoff On Valve.</p> <p>IF NO: Check wiring between the ignition module and the valve. Repair/replace wires as required. If wiring is OK, replace ignition module. IF YES: Replace gas valve.</p>
Low gas outlet pressure.	<p>Check gas manifold pressure. Measure manifold pressure at the pressure tap on the gas valve.</p> <p>Check gas manifold pressure. Measure manifold pressure at the pressure tap on the gas valve. Natural Gas: 4.0" w.c. LP Gas: 10.0" w.c. If manifold pressure does not meet requirements, adjust valve outlet pressure with the adjustment screw on the valve. NOTE: Proper inlet gas pressure must be verified before performing outlet pressure testing.</p>

BURNER DOES NOT STAY LIT	
Possible Cause	Try this.....
Damaged wires between DSI module and electrode.	Replace wires as required.
Faulty DSI module	Replace DSI module.
Damaged Electrode	Replace Electrode

Section 8 ILLUSTRATED PARTS

Illustrated Parts

This section provides the part numbers and pictorials for components of the MHT tube heater. Callout letters on the illustrations are keyed to the associated parts list.

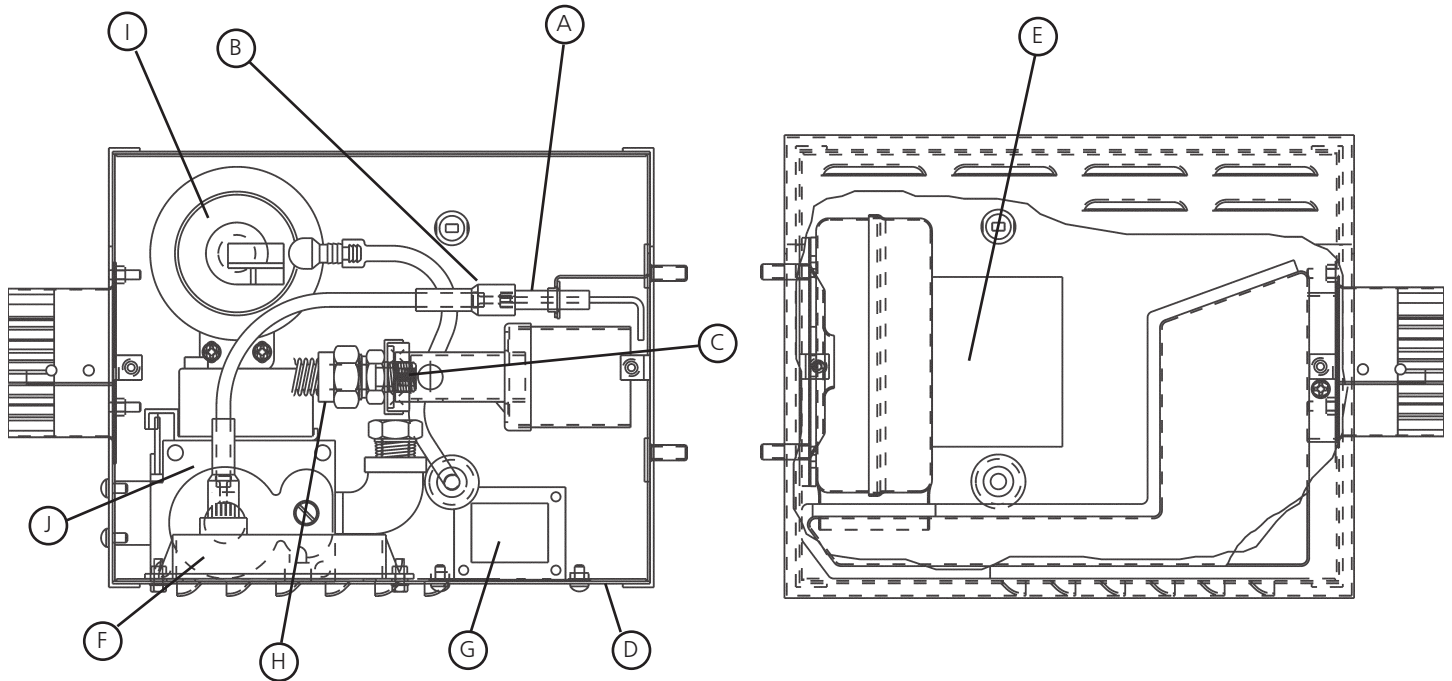

ITEM	PART NUMBER	DESCRIPTION	HST-35	HST-45
A	02808	Spark Electrode	1	1
B	02837	Ignition Wire	1	1
	05795	Orifice (MHT 45 NG)	*	1
	05747	Orifice (MHT 45 LP)	*	1
D	02795	Sight Window	1	1
E	02814	Blower Motor	1	1
F	02810	Ignition Module	1	1
G	08364A	Transformer	1	1
H	02806	Manifold	1	1
I	02822	Pressure Switch (HST35/45)	1	1
J	02812	Gas Valve (N.G.)	1	1
	02811	Gas Valve (L.P.)	1	1

Mr. Heater • Model #MHT 45 Tube Heater

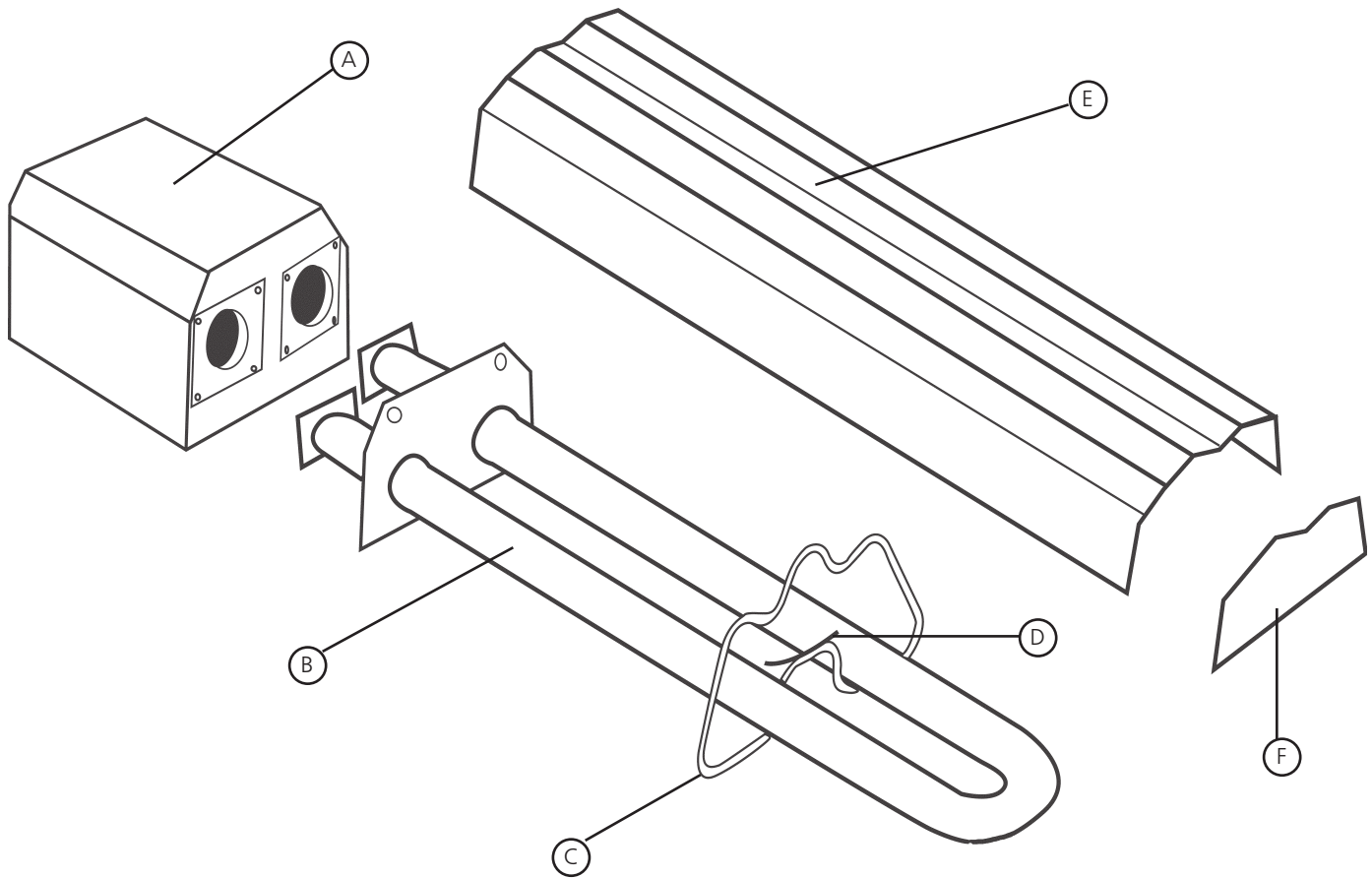

REPLACEMENT PARTS LIST FOR HEATER MODEL MHT TUBE HEATER

REF.#	ITEM#	DESCRIPTION
A	F202850	MHT-45NG Burner Box for (F208850)
	F202851	MHT-45LP Burner Box for (F202851)
B	F106250	MHT45 Tube Set (Long)
C	06014	Hanger
D	06016	Hanger Clamp
E	06008-9	MHT-45 Reflector (Long)
F	06009	Reflector End Cap

ALL WARRANTY CLAIMS REQUIRE PROOF OF PURCHASE



OPERATING INSTRUCTIONS AND OWNER'S MANUAL

Model #

MHT 45

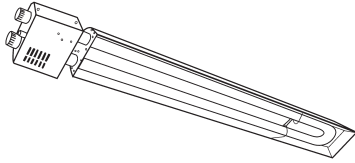

WARNING:

USE ONLY MANUFACTURER'S REPLACEMENT PARTS. USE OF ANY OTHER PARTS COULD CAUSE INJURY OR DEATH. REPLACEMENT PARTS ARE ONLY AVAILABLE DIRECT FROM THE FACTORY AND MUST BE INSTALLED BY A QUALIFIED SERVICE AGENCY.

FOR INFORMATION REGARDING SERVICE OR PARTS:

Contact your local heating service technician or dealer.

FOR ADDITIONAL INFORMATION:

Please call Toll-Free 800-251-0001—www.mrheater.com

Our office hours are 8:30 AM — 5:00 PM, EST, Monday through Friday.

Please have the model number, serial number and date of purchase ready.

LIMITED WARRANTY

The company warrants this product to be free from imperfections in material or workmanship, under normal and proper use in accordance with instructions of The Company, for a period of one year from the date of delivery to the buyer. The Company, at its option, will repair or replace products returned by the buyer to the factory, transportation prepaid within said one year period and found by the Company to have imperfections in material or workmanship.

If a part is damaged or missing, call our Customer Service Department at 800-251-0001.

Address any Warranty Claims to the Customer Service Department, Mr. Heater, 4560 W. 160TH ST., CLEVELAND, OHIO 44135. Include your name, address and telephone number and include details concerning the claim. Also, supply us with the purchase date and the name and address of the dealer from whom you purchased our product.

The foregoing is the full extent of the responsibility of the Company. There are no other warranties, express or implied. Specifically there is no warranty of fitness for a particular purpose and there is no warranty of merchantability. In no event shall the Company be liable for delay caused by imperfections, for consequential damages, or for any charges of the expense of any nature incurred without its written consent. The cost of repair or replacement shall be the exclusive remedy for any breach of warranty. There is no warranty against infringement of the like and no implied warranty arising from course of dealing or usage of trade. This warranty will not apply to any product which has been repaired or altered outside of the factory in any respect which in our judgment affects its condition or operation.

Some states do not allow the exclusion or limitation of incidental or consequential damages, so the above limitation or exclusion may not apply to you. This Warranty gives you specific legal rights, and you may have other rights which vary from state to state.

Mr. Heater reserves the right to make changes at any time, without notice or obligation, in colors, specifications, accessories, materials and models.



CSA REQUIREMENT 7-89
ANSI Z21.86B 2002
ANS Z83.20 • CSA 2.34-2003

Mr. Heater Corporation, 4560 W. 160TH ST., CLEVELAND, OHIO 44135 • 216-916-3000
© 2003, Mr. Heater. All rights reserved

Free Manuals Download Website

<http://myh66.com>

<http://usermanuals.us>

<http://www.somanuals.com>

<http://www.4manuals.cc>

<http://www.manual-lib.com>

<http://www.404manual.com>

<http://www.luxmanual.com>

<http://aubethermostatmanual.com>

Golf course search by state

<http://golfingnear.com>

Email search by domain

<http://emailbydomain.com>

Auto manuals search

<http://auto.somanuals.com>

TV manuals search

<http://tv.somanuals.com>