

USER GUIDE

CallFinder™ CF220

DID-to-Analog Telephony Adapter

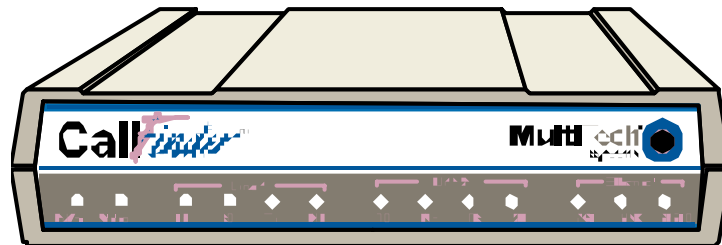

User Guide

MultiTech[®]
Systems 

CallFinder™ User Guide Model CF220 DID-to-Analog Adapter

PN S000350A, Version A

Copyright

This publication may not be reproduced, in whole or in part, without prior expressed written permission from Multi-Tech Systems, Inc. All rights reserved.

Copyright © 2004, by Multi-Tech Systems, Inc.

Multi-Tech Systems, Inc. makes no representations or warranties with respect to the contents hereof and specifically disclaims any implied warranties of merchantability or fitness for any particular purpose.

Furthermore, Multi-Tech Systems, Inc. reserves the right to revise this publication and to make changes from time to time in the content hereof without obligation of Multi-Tech Systems, Inc. to notify any person or organization of such revisions or changes.

Revisions

<i>Revision Level</i>	<i>Date</i>	<i>Description</i>
A	12/23/04	Initial release.

Patents

This device covered by the following patent: 5,673,268

Trademarks

Multi-Tech Trademarks: CallFinder, Multi-Tech, and the Multi-Tech logo.

All other products and technologies are the trademarks or registered trademarks of their respective holders.

World Headquarters

Multi-Tech Systems, Inc.
2205 Woodale Drive
Mounds View, Minnesota 55112
Phone: 763-785-3500 or 800-328-9717
Fax: 763-785-9874

Technical Support

Country

France:

India:

U.K.:

U.S. and Canada:

Rest of the World:

Internet Address: <http://www.multitech.com>

By Email

support@multitech.fr

support@multitechindia.com

support@multitech.co.uk

oemsales@multitech.com

oemsales@multitech.com

By Phone

(33) 1-64 61 09 81

91 (124) 6340778

(44) 118 959 7774

(800) 972-2439

(763) 717-5863

Table of Contents

CHAPTER 1 – PRODUCT DESCRIPTION AND SPECIFICATIONS	5
PRODUCT DESCRIPTION	5
PRODUCT FEATURES	5
PREREQUISITE: ORDERING THE DID LINE	6
SAFETY WARNINGS	6
TECHNICAL SPECIFICATIONS	7
RELATED MANUALS	7
CHAPTER 2 – SAMPLE SYSTEM.....	8
Introduction	8
Spigglebrim's Initial Situation.....	9
Step 1 Practical: Add CallFinder and connect to network.....	10
Step 1 Technical: Enter addresses of network servers in CF software.....	11
Step 2 Practical: Add DID lines and connect to CallFinder.....	12
Step 2 Technical: Enter operating parameters of DID lines.....	13
Step 3 Practical: Connect CallFinder port (FXO) to PBX for conventional DID service (Purchasing Dept.) ..	14
Step 3 Technical: Enter operating parameters of CallFinder channel (FXO)	15
Step 4 Practical: Connect CallFinder port (FXS) to PBX for special DID service (Field Support Dept.)	16
Step 4 Technical: Enter operating parameters of CallFinder channel (FXS).....	17
Step 5 Practical: Map PBX Extensions to DID Numbers.....	18
Step 5 Technical: Create CallFinder Phonebook.....	19
Step 6: Administering the CallFinder System.....	20
Conclusion.....	21
CHAPTER 3 – CALLFINDER SERVER INSTALLATION.....	22
PREREQUISITE: ORDERING THE DID LINE	22
WE SUPPLY	22
YOU SUPPLY	23
INSTALLATION, PART A: CONNECTING THE CALLFINDER TO POWER OUTLETS, PHONE LINES, AND ETHERNET	23
1. Connect CallFinder 5Vdc Power Supply to AC Outlet.....	23
2. Connect CallFinder 48Vdc Power Supply to AC Outlet.....	23
3. Identify CallFinder's Extension Ports (FXS/FXO) for Later Hookup	23
4. Connect CallFinder to DID Lines	24
5. Connect CallFinder to Ethernet Network.....	24
6. Do Power-On Test.....	24
PART B: CONFIGURING THE CALLFINDER SERVER.....	25
1. Collecting Configuration Data	25
2. Setting Admin PC to Startup IP Address	27
3. Logging In (I).....	27
4. Setting CallFinder IP Addresses.....	28
5. Resetting Admin PC to Its Regular IP Address.....	28
6. Logging In (II)	28
7. Setting Administrative Functions.....	29
8. Setting Up the Mail Server.....	30
9. Configuring the CallFinder's Channels	31
10. Connecting CallFinder to PBX.....	32
11. Testing the Channel with a Call	32
12. Changing Administrator's Password for CallFinder SW	33
13. Assigning DID Numbers to PBX Users (Extensions).....	33
CHAPTER 4 – CALLFINDER SOFTWARE SCREENS	34
Home Screen.....	34
Login Screen.....	35
Call Log Screen	36

<i>Current Status Screen</i>	37
<i>Logout Option</i>	38
<i>Help Screen</i>	38
<i>Administration Screen</i>	39
<i>Phone Book Screen</i>	42
<i>Channel Configuration Screen</i>	44
<i>Password Administration Screen</i>	46
CHAPTER 5 – CALLFINDER SERVER OPERATION	47
<i>Front Panel LEDs</i>	47
<i>Updating CallFinder Firmware</i>	47
<i>Call Log Email Messages</i>	48
<i>Initializing and Busying DID Channel Modems</i>	48
CHAPTER 6 - FFCF MANAGER INSTALLATION	49
<i>Introduction</i>	49
<i>Installing FFCF Manager Software</i>	50
<i>Uninstalling or Reinstalling the FFCF Manager Software</i>	51
CHAPTER 7 - FFCF MANAGER OPERATION	55
<i>Introduction</i>	55
<i>FFCF Manager Command Summary</i>	55
<i>Opening the FFCF Manager Software</i>	56
<i>FFCF Manager Main Screen</i>	57
<i>FFCF Manager “Edit” Menu</i>	59
<i>Right-Click Menu for Selected CallFinder Device</i>	63
FIRMWARE UPDATING PROCESS - DETAILED	69
<i>CallFinder Channel-Modem Firmware Update</i>	69
<i>CallFinder Server Firmware Update</i>	73
CHAPTER 8: TROUBLESHOOTING	77
<i>1. What if I can't see the web page for my CallFinder ?</i>	77
<i>2. What if I don't get an email when I set the mail server address ?</i>	77
<i>3. What if the CallFinder channel doesn't answer a call on the DID line?</i>	79
<i>4. What if the CallFinder presents the wrong time of day?</i>	79
<i>5. What if an immediate busy signal is received when dialing in on the DID line?</i>	79
<i>6. What if the line suddenly disconnects just when a call is about to be connected?</i>	79
CHAPTER 9 – REGULATORY INFORMATION	80
<i>47 CFR PART 68 TELECOM</i>	80
<i>47 CFR PART 15 REGULATION</i>	81
<i>FAX BRANDING STATEMENT</i>	81
<i>CANADIAN LIMITATIONS NOTICE</i>	82
<i>INDUSTRY CANADA</i>	82
CHAPTER 10: WARRANTY, SERVICE, & REPAIR	83

Chapter 1 – Product Description and Specifications

Product Description

The CallFinder is a DID-to-analog telephony adapter. It brings analog DID services to a key telephone system or PBX that is not DID-enabled. When equipped with the CallFinder, the phone system can route incoming calls directly to end-user extensions. The CallFinder has two DID channels. Each channel is connected to the telco DID line on one side and to the PBX/key system on the other side. A CallFinder extension port can be connected either to a trunk port or to a station port on a PBX. The choice between trunk port or station port connections depends on port availability, logging requirements, and/or on whether it is necessary for incoming DID calls to be treated like outside calls instead of intra-PBX calls.

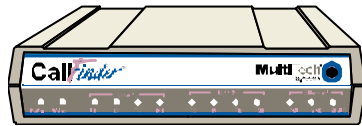

Multi-Tech's CF220 CallFinder™ DID-to-Analog Telephony Adapter

The CallFinder product consists of the hardware unit with pre-installed configuration software.

Product Features

- Direct routing of incoming calls to end-user extensions
- Two Direct Inward Dial (DID) ports
- Two extension ports programmable as FXS or FXO
- DID ports support wink-start, immediate-start, and delay-dial service types
- Interfaces with most call-processing systems
- Supports audio ringback and busy pass-through
- Web interface for system configuration and management
- PC-based software to manage multiple CallFinders in same system
- Flash memory for easy updates
- Small footprint external chassis
- Two-year warranty

Prerequisite: Ordering the DID Line

To operate the CallFinder system, you will need two DID (Direct Inward Dial) lines in your office. You must order the DID line from your local telephone operating company (telco). A DID line allows one phone line to be associated with multiple directory numbers. However, only one call can occur on this line at any given time.

DID lines are sold in groups. For example, a telco in New York City might offer a DID line with a set of 20 directory numbers in the range of 212-555-4101 through 212-555-4120.

When ordering your DID line(s), ask the telco representative for these details about the DID service. These details will be important when setting up your CF220 DID Adapter.

Parameter	Value Required by Telco
Number of digits used to designate the DID extension (usually 3, 4, 6, or 7)	
Type of "DID Start" used (wink, immediate, or delay dial)	

You will need this information to configure your CallFinder DID Adapter (see *Chapter 3: CallFinder Server Installation*).

Safety Warnings

- Use this product only with UL- and CUL-listed computers (US).
- Caution: this unit has two power adaptors. To disconnect power from the unit, *both* power cords must be removed to avoid electrical shock.
- Never install phone wiring during a lightning storm.
- Never install a phone jack in a wet location unless the jack is specifically designed for wet locations.
- Never touch uninsulated phone wires or terminals unless the phone line has been disconnected at the network interface.
- Use caution when installing or modifying phone lines.
- Avoid using a phone during an electrical storm; there is a risk of electrical shock from lightning.
- Do not use a phone in the vicinity of a gas leak.
- To reduce the risk of fire, use only 26 AWG or larger telephone line cord.

Technical Specifications

The CF220 CallFinder meets the following specifications:

Connectors	2 - RJ11-FXO/FXS Jacks, 2 - RJ12-DID line, RJ45 - Ethernet Jack
Size	6"w, 1.5"h, 9"d 15.2 cm x 3.8 cm x 22.9 cm
Weight	0.90Kg 2lb
Power Consumption	Typical 8.8W (0.80A @5v DC + 0.10A @48vDC) Maximum 23.8W (0.88A @5.25v DC + 0.40A @ 48v DC)
Operating Environment	32-120 degrees F (0-50 degrees C) relative humidity 20 to 90% noncondensing
EMC Approvals	FCC Part 15 Class B, Canada Class B, EN 55022 Class B, EN55024,
Safety Approvals	UL, cUL, UL60950, CSA 950, EN60950, AS3260, CCIB (China)
Telecom Approvals	FCC Part 68, CS03

Related Manuals

The CF220 CallFinder unit comes with two manuals that serve different purposes:

Title	Format	Purpose
User Guide (this manual)	on CD	Presents comprehensive info about CallFinder unit and its software.
Quick Start Guide	in print	Use this manual to set up the CallFinder unit and configure its software.

Multi-Tech manuals and other resources are available on the Multi-Tech Web page at <http://www.multitech.com>.

Chapter 2 – Sample System

Introduction

The Spigglebrim Vacuum Cleaner Company wants to use DID lines for its Field Support and Purchasing Departments. Alas, the company's PBX is not equipped for DID service and a new PBX will not be in the budget anytime soon.

This chapter shows how this fictitious company might use MultiTech's CF220 CallFinder to solve its problem.

For years, the receptionist/operator has been routing calls to various specialists within the company, but, as the company has grown, this has become increasingly difficult. Spigglebrim's Field Support Department wants to give customers a permanent set of incoming phone numbers so they can reach employees who have expertise with different kinds of vacuum cleaner systems. Spigglebrim's Purchasing Department wants to give vendors a permanent set of incoming phone numbers so they can reach purchasing agents responsible for different kinds of parts. Spigglebrim wants flexibility in routing calls because employees must cover different shifts and sometimes substitute for each other (during vacations, etc.). Yet they want to avoid moving employees from office to office. They want to cross-train employees in different specialties. Spigglebrim also wants to use an automated timed billing system to charge for Field Support calls.

Spigglebrim Field Support Specialties		Spigglebrim Purchasing Specialties
Upright		Bags
Canister		Belts
Wet/Dry		Motors
Battery		Frames
Commercial		Attachments

In the following pages we show the setup for a CallFinder system that meets the company's needs. On each double-page spread, we show, on the left, the setup at a practical level and, on the right, the setup as done through the CallFinder's built-in software (accessible via web browser).

Spigglebrim's Initial Situation

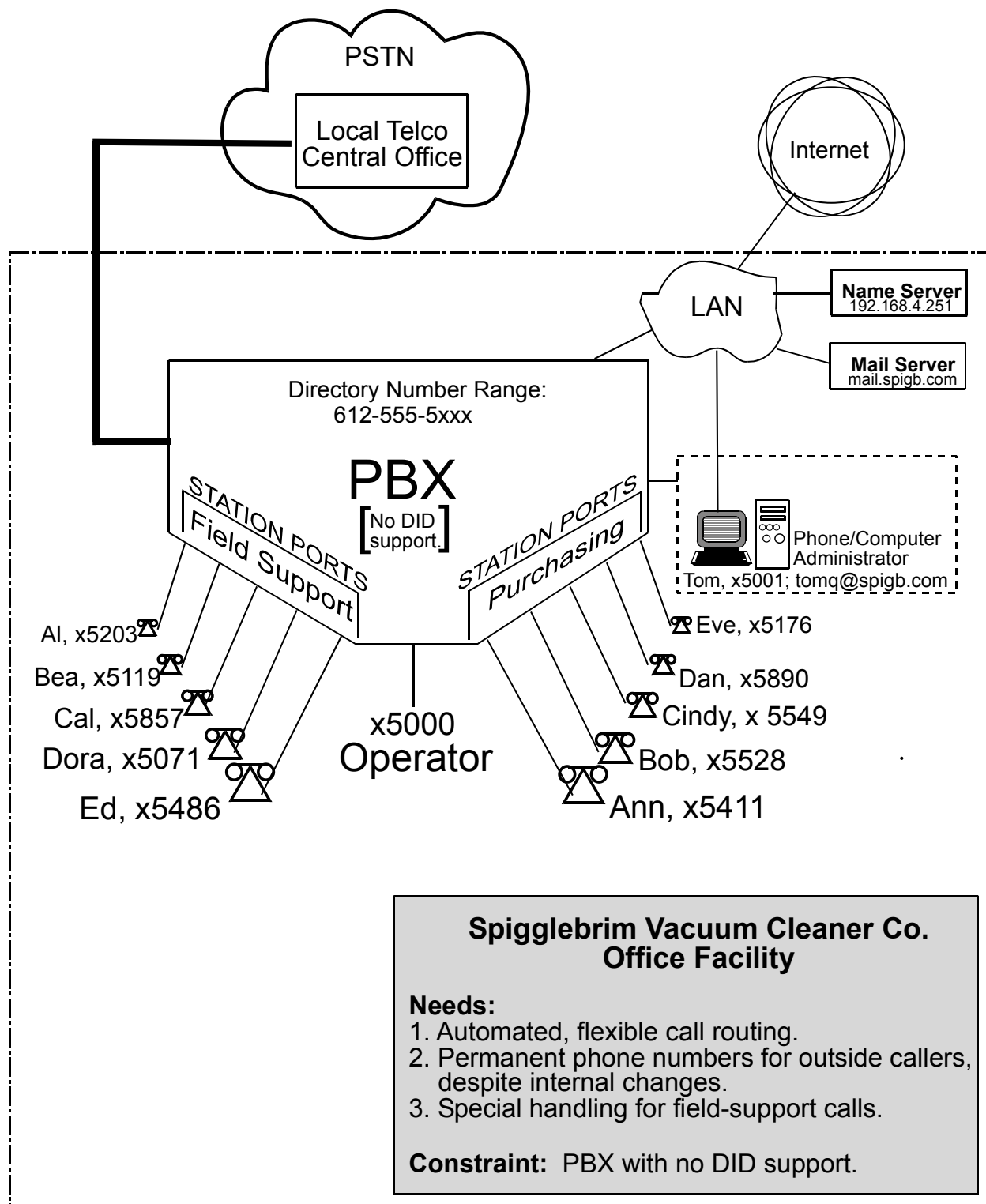

Step 1 Practical: Add CallFinder and connect to network.

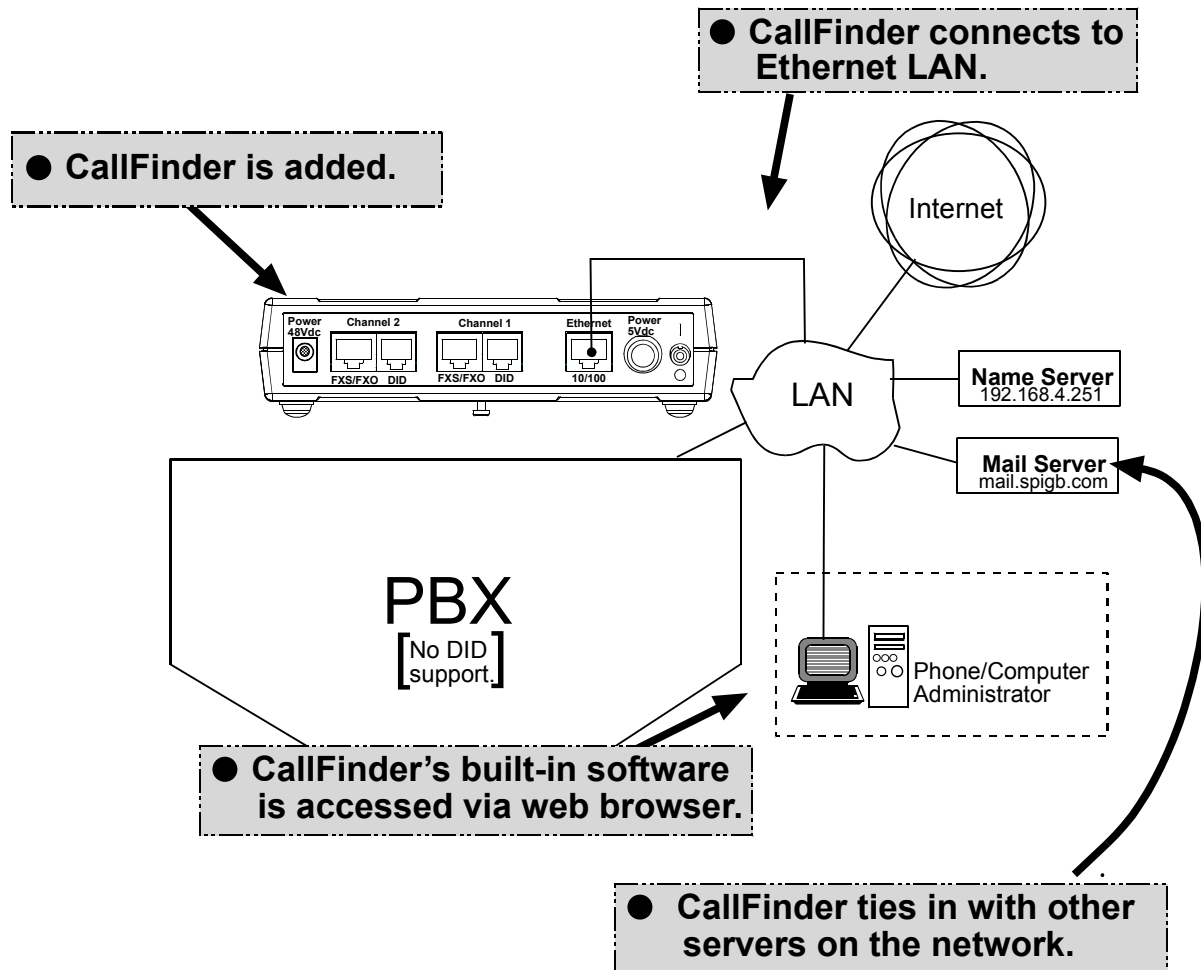

Step 1 Technical: Enter addresses of network servers in CF software.

Once assigned an IP address on the network, the CallFinder's software (configured via web browser) can link it to other servers on the network.

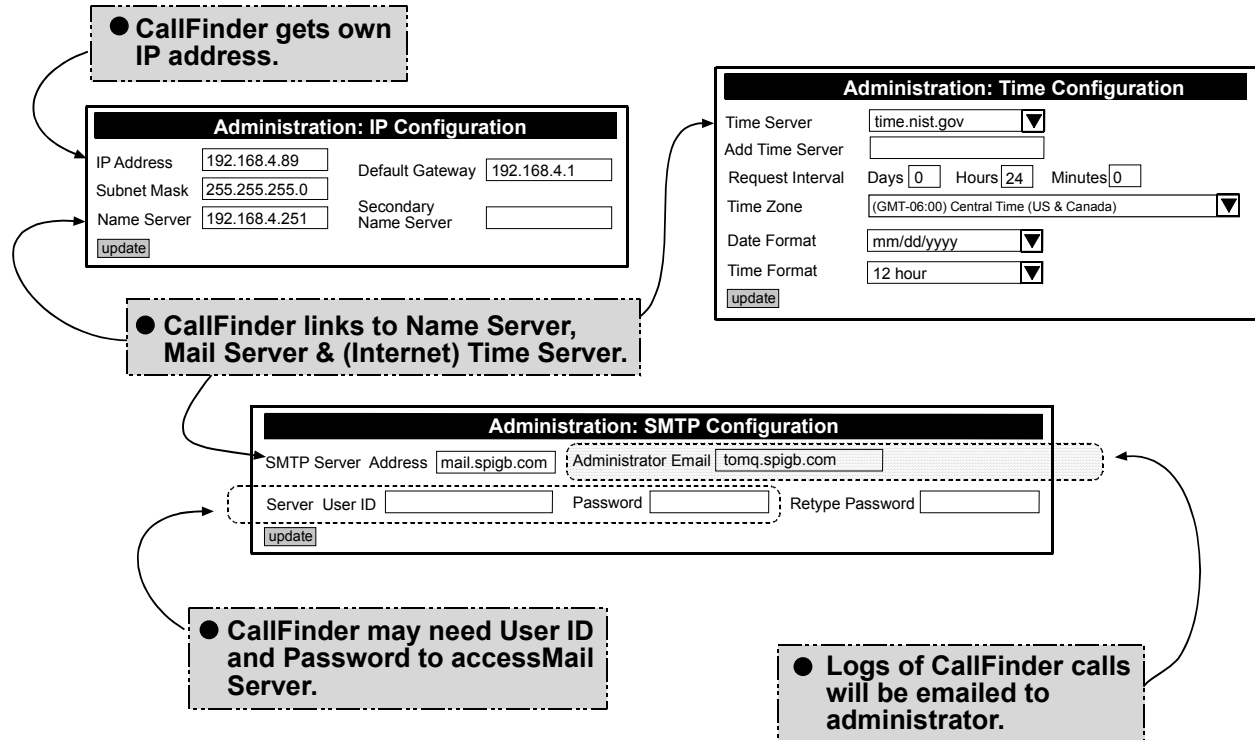

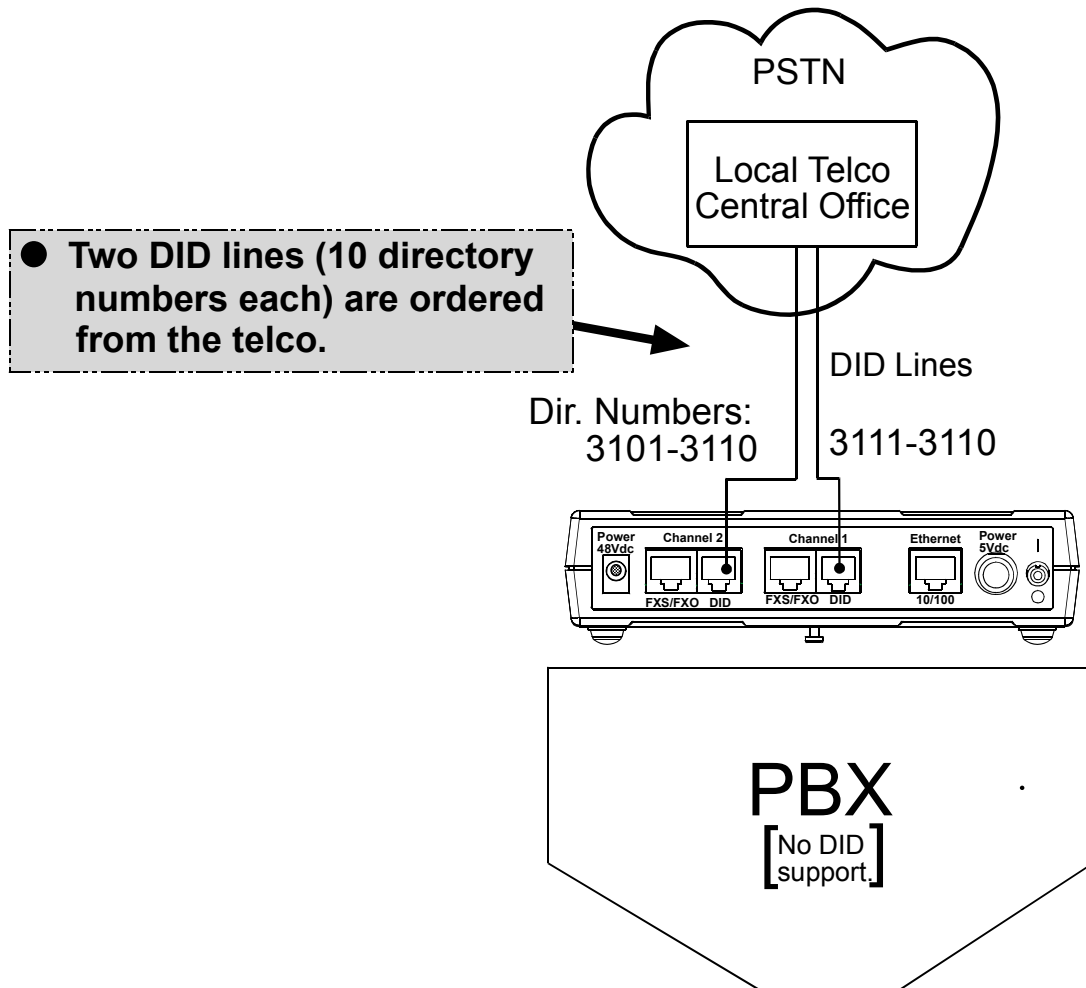
Step 2 Practical: Add DID lines and connect to CallFinder.

Step 2 Technical: Enter operating parameters of DID lines.

Each DID line has 3 user-specified technical parameters. You set them in the CallFinder software.

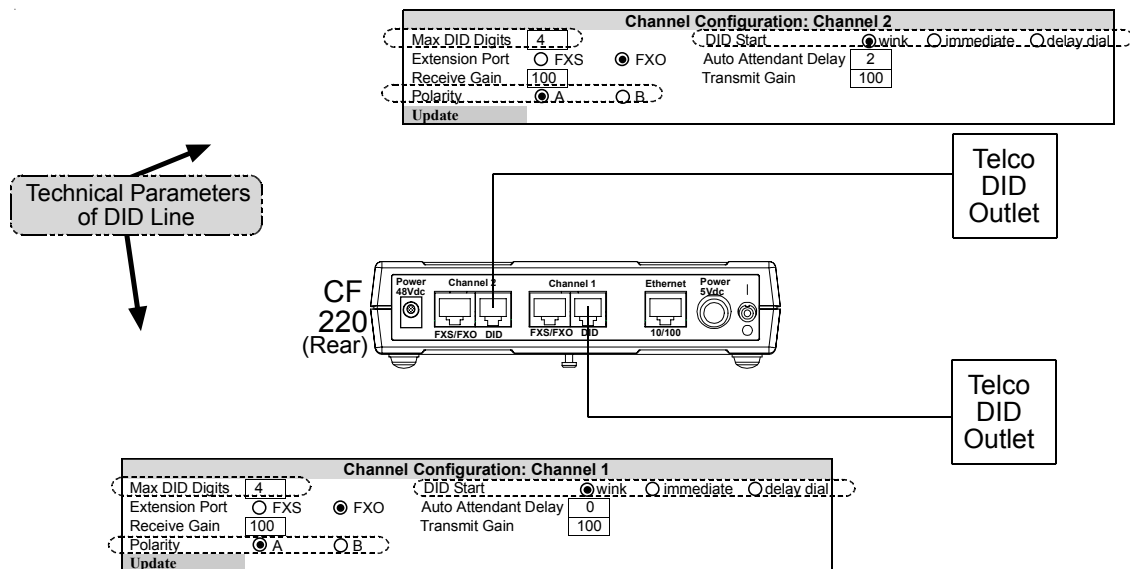

Technical Parameters Related to DID Line

Parameter	Value	Comments
Max DID Digits	4	Number of digits received on DID line.
Polarity	try A	This is a trial-and-error setting. The DID line is a twisted pair. Only when installed can you know polarity. You determine the polarity by performance – with wrong polarity, connections cannot be made.
DID Start	ask telco	Start mode varies with different implementations of DID.

Step 3 Practical: Connect CallFinder port (FXO) to PBX for conventional DID service (Purchasing Dept.).

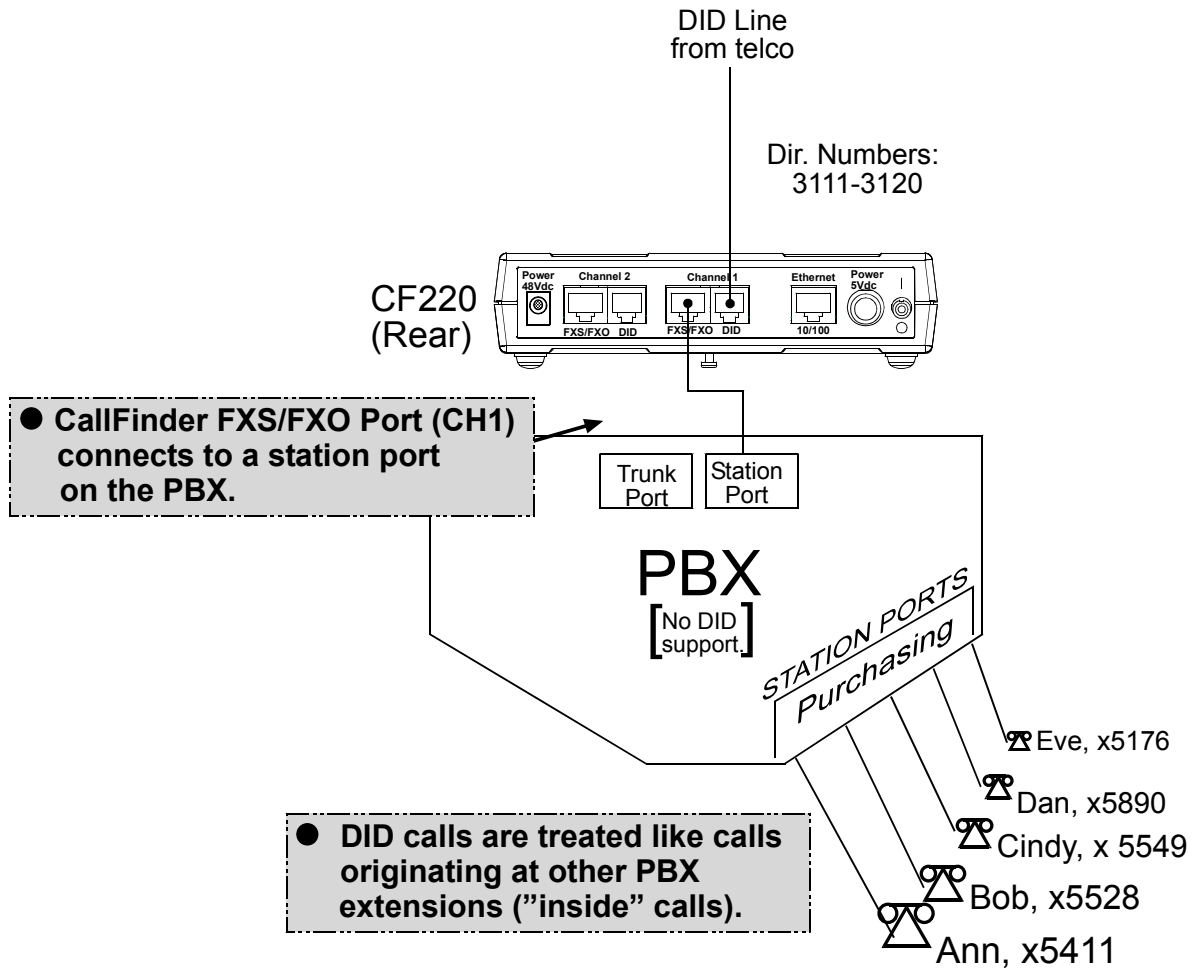

Step 3 Technical: Enter operating parameters of CallFinder channel (FXO)

Each of the CallFinder's DID-channel modems has 4 user-specified parameters. You set them in the CallFinder software.

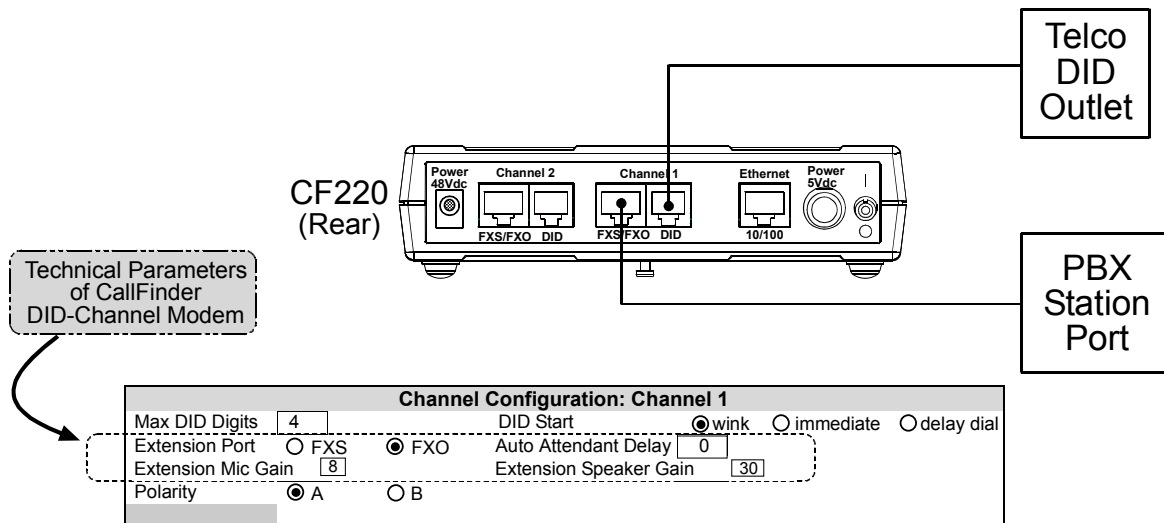

Technical Parameters Related to CallFinder's Extension Port Line

Parameter	Value	Comments
Extension Port	FXO	Use FXO whenever CallFinder channel connects to PBX station port.
Auto Attendant Delay	0 (in seconds)	Describes how long the CallFinder waits before dialing. If set to 0, CallFinder calls as soon as PBX dial tone is present. If no dial tone is present, the call cannot be completed.
Extension Mic Gain	8	This describes the amplification of the sound input at the local phone user's mouthpiece microphone. The default value is typically appropriate. <i>This is a very sensitive parameter and mis-adjustment can render the channel inoperable.</i> Adjust carefully and only if needed.
Extension Speaker Gain	30	This describes the amplification of the sound output at the local phone user's earpiece speaker. The default value is typically appropriate. <i>This is a very sensitive parameter and mis-adjustment can render the channel inoperable.</i> Adjust carefully and only if needed.

Step 4 Practical: Connect CallFinder port (FXS) to PBX for special DID service (Field Support Dept.).

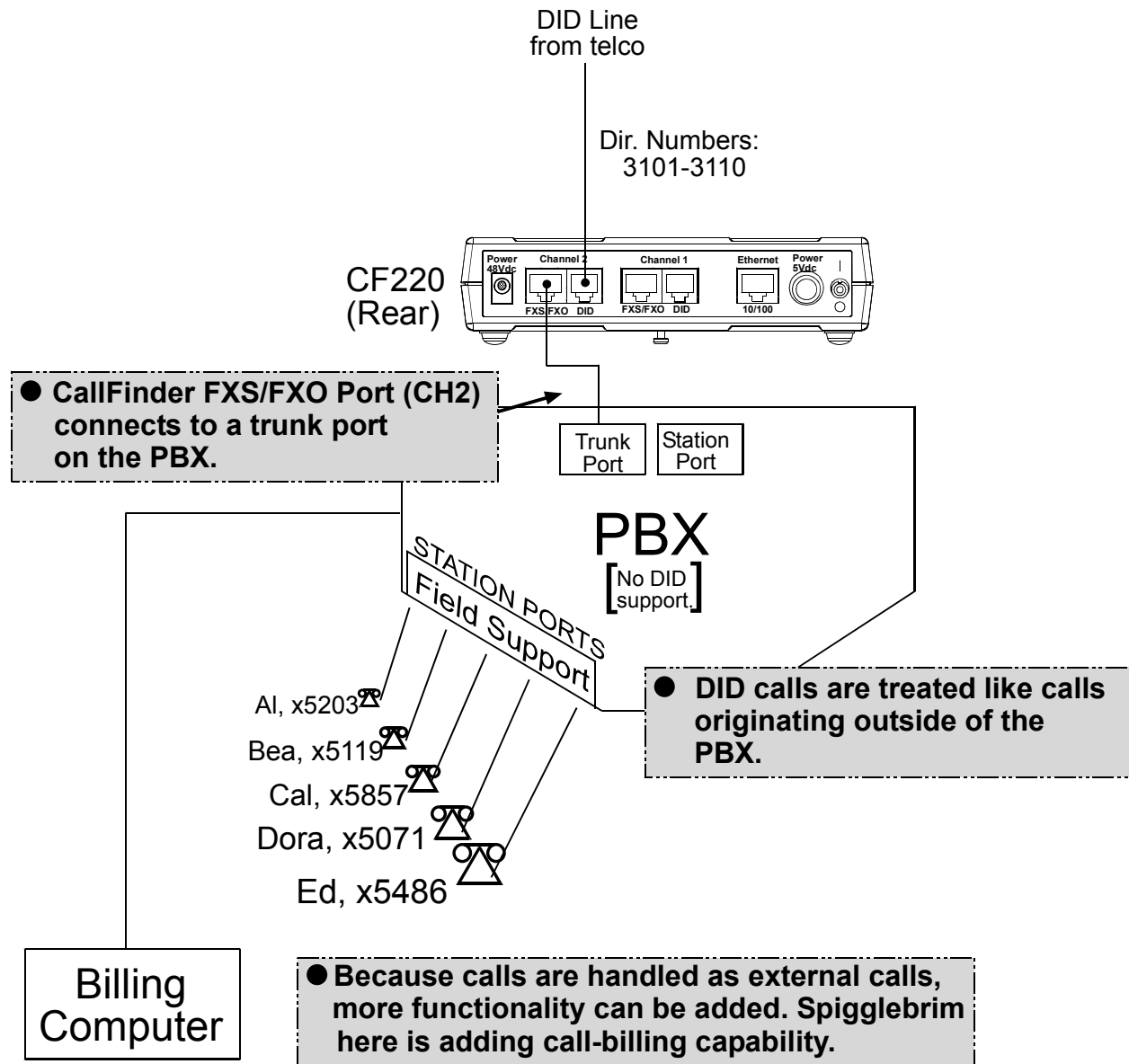

Step 4 Technical: Enter operating parameters of CallFinder channel (FXS).

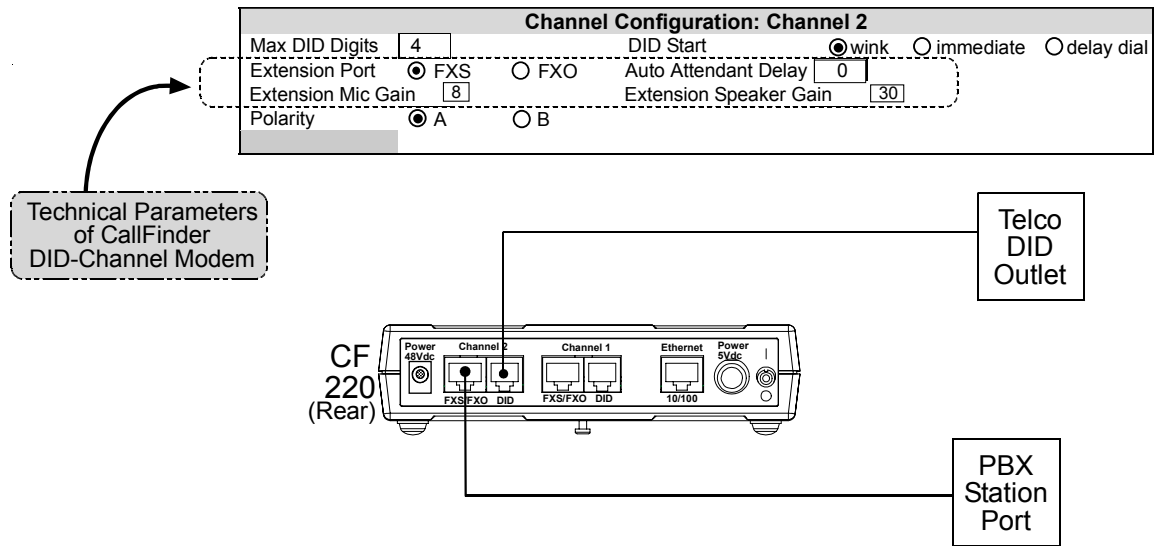

Step 5 Practical: Map PBX Extensions to DID Numbers

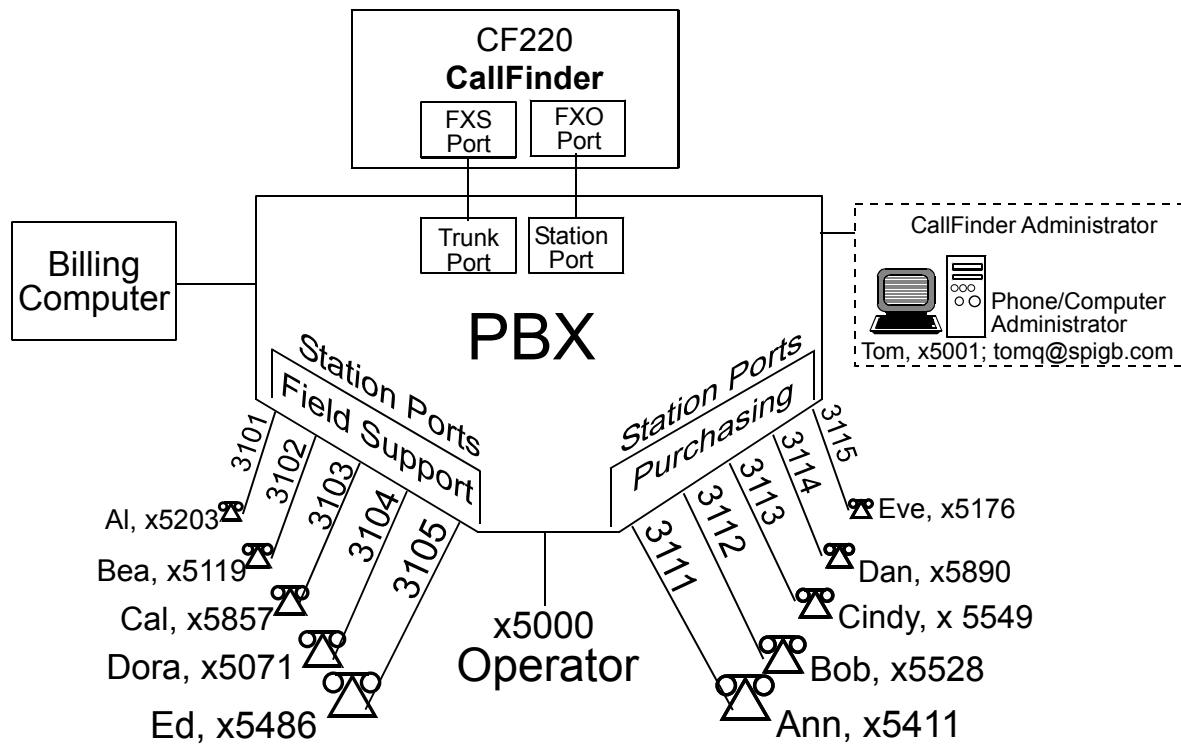

Step 5 Technical: Create CallFinder Phonebook.

[Home](#) | [Login](#) | [Call Log](#) | [Current Status](#) | [Logout](#) | [Help](#)
[Administration](#) | [Phone Book](#) | [Channel Configuration](#) | [Password Administration](#)

Phone Book

Success: Eve was updated

Name	DID #	Extension	Function
Unassigned Number		5000	<input type="button" value="update"/> <input type="button" value="delete"/>
Al	3101	5203	<input type="button" value="update"/> <input type="button" value="delete"/>
Bea	3102	5119	<input type="button" value="update"/> <input type="button" value="delete"/>
Cal	3103	5857	<input type="button" value="update"/> <input type="button" value="delete"/>
Dora	3104	5071	<input type="button" value="update"/> <input type="button" value="delete"/>
Ed	3105	5486	<input type="button" value="update"/> <input type="button" value="delete"/>
Ann	3111	5411	<input type="button" value="update"/> <input type="button" value="delete"/>
Bob	3112	5528	<input type="button" value="update"/> <input type="button" value="delete"/>
Cindy	3113	5549	<input type="button" value="update"/> <input type="button" value="delete"/>
Dan	3114	5890	<input type="button" value="update"/> <input type="button" value="delete"/>
Eve	3115	5176	<input type="button" value="update"/> <input type="button" value="delete"/>
			<input type="button" value="add"/>

Purchasing Dept. Field Support

This phonebook arrangement connects the five Field Support users to the CallFinder through one of the PBX's trunk ports (using DID numbers 3101 through 3105). This facilitates the use of a billing computer for Field Support calls. The five Purchasing Department users are connected to the CallFinder through one of the PBX's station ports (using DID number 3111 through 3115). Because station ports are always more numerous than trunk ports in PBXs, CallFinder channels are more likely to be connected to PBX station ports than to PBX trunk ports in most systems.

If any outside caller dials 612-555-3106 or any other unused DID number will reach the receptionist operator (x5000).

Step 6: Administering the CallFinder System

**Multi-Tech CallFinder Call Router
Model CF220 - Version 1.0**

Username

Password

Login

For initial Login, use:

**admin
admin**

Then change Login later.

Administration: SMTP Configuration

SMTP Server Address Administrator Email

Server User ID Password Retype Password

Update

Designate an administrator to receive call-logs via email.

Determine whether company's email server requires User-ID and Password for login authentication. Give CF220 such a user-ID and password if needed. *This is different than administrator's Username & Password.*

Home | Login | Call Log | Current Status | Logout | Help

Administration | Phone Book | Channel Config | Password Admin

Phone Book

Name	DID #	Extension	Function
Administrator	3109	5001	update delete
Unassigned Number		5000	update delete
AI	3101	3203	update delete

Designate someone to take calls made to unassigned DID numbers.

FaxFinder/CallFinder Manager

File Edit Help

Dev	Synchronize Phonebooks	Status	Version
192.	Add FaxFinder/CallFinder	idle	0.78
192.168.3.78 (CF220) Primary		idle	0.78

Install FaxFinder/CallFinder Manager software. It lets you:

- add more CallFinders to system
- update firmware
- synchronize phone books among multiple CallFinders in system

Conclusion

The CallFinder solved Spigglebrim's problem. It added DID functionality to their existing PBX. Al in the Field Support Department can now receive calls from the outside (dialed to 612-555-3101) while taking both internal and external calls using his 5203 PBX extension number. Al's Field Support calls are handled as outside calls and they can be registered with a billing computer. Ann in the Purchasing Department receives external calls (dialed to 612-555-3111) while taking both internal and external calls using her 5411 PBX extension number. If either Al or Ann go on vacation, their incoming DID lines can be re-directed in the CallFinder to another employee who knows their specialties. Spigglebrim Vacuum Cleaners will be humming along for years to come.

Chapter 3 – CallFinder Server Installation

This chapter shows you how to set up your Multi-Tech Model CF220 CallFinder.

The setup process entails cabling the CF220 unit and configuring the CallFinder software. The CallFinder software resides on the CallFinder unit and does not need to be installed.

Prerequisite: Ordering the DID Line

To use the CallFinder system, you will need one or two DID (Direct Inward Dial) lines in your facility. You must order the DID line(s) from your local telephone operating company (telco). A DID line allows one phone line to be associated with multiple directory numbers. However, only one call can occur on this line at any given time.

DID lines are sold in groups. For example, a telco in New York City might offer a DID line with a set of 20 directory numbers in the range of 212-555-4101 through 212-555-4120.

When ordering your DID line, ask the telco representative for these details about the DID service. These details will be important when setting up your CF220 DID Adapter.

Parameter	Value Required by Telco
Number of digits used to designate the DID extension (usually 3, 4, 6, or 7)	
Type of "DID Start" used (wink, immediate, or delay dial)	

You will need this information to configure your CallFinder (see step 8 on page 25).

We Supply

- A CF220 CallFinder with factory-installed software
- Two power supplies – one 5Vdc and one 48Vdc
- Two common telephone cables (RJ11 at both ends)
- Two DID telephone cables (RJ11 at one end; RJ12 at other end)
- A utility software program for updating CallFinder firmware
- This printed Quick Start Guide

You Supply

- Two nearby AC power outlets
- Two nearby connections to a PBX
- A connection to your Ethernet LAN
- One or two nearby analog DID trunk lines each with a block of associated DID telephone numbers
- A PC with Ethernet connection and web browser from which to configure the CallFinder unit. (Windows or Linux can be used to access the CallFinder software. Windows NT, Windows 2000, or Windows XP are required to access the FaxFinder/CallFinder Manager software.)

Installation, Part A: Connecting the CallFinder to Power Outlets, Phone Lines, and Ethernet

Summary: Place the CallFinder in a convenient location, and then connect it to your AC power outlets and Ethernet. Before connecting the extension lines, you need to know whether the CallFinder's ports will function as FXO or FXS. The CallFinder's default extension interface setting is FXO to prevent damage from a mistaken connection. Be aware that an incorrect connection could damage the CallFinder unit or the PBX. *Do not connect FXS to FXS.*

1. Connect CallFinder 5Vdc Power Supply to AC Outlet

Make sure the power switch is OFF. Plug the DC power transformer for the 5 Vdc power supply into a power outlet or power strip. Plug the other end into the "Power 5Vdc" jack on your CallFinder. The DC power transformer is included with your CallFinder.

Caution: Use only the 5 Vdc power transformer supplied with the CallFinder. Use of any other transformer voids the warranty and can damage the CallFinder. *The CallFinder's 5Vdc and 48 Vdc power supplies have different connector types to prevent mix-ups.*

2. Connect CallFinder 48Vdc Power Supply to AC Outlet

Make sure the power switch is OFF. Plug the DC power transformer for the 48 Vdc power supply into a power outlet or power strip. Plug the other end into the "Power 48 Vdc" jack on your CallFinder. The DC power transformer is included with your CallFinder.

Caution: Use only the 48 Vdc power transformer supplied with the CallFinder. Use of any other transformer voids the warranty and can damage the CallFinder. *The CallFinder's 5Vdc and 48 Vdc power supplies have different connector types to prevent mix-ups.*

3. Identify CallFinder's Extension Ports (FXS/FXO) for Later Hookup

Caution: You must wait until after the CallFinder software has been configured before connecting the cables between the CallFinder's Extension (FXS/FXO) Ports and the PBX. Because the CallFinder and the PBX can both supply battery power, the cable connections must be done properly. Otherwise equipment damage could occur.

Before making connections to the CallFinder Extension (FXS/FXO) channels, you must know the type of PBX port to which each CallFinder port will be connected and set the "Extension Port" field in the CallFinder **Channel Configuration** screen appropriately.

When connecting to a PBX Station Port,
set the CallFinder channel to FXO.

When connecting to a PBX Trunk Port,
set the CallFinder channel to FXS.

When the **Channel Configuration | Extension Port** software field has been set properly for both CallFinder channels, you can proceed to connect the cable between each of the CallFinder's FXS/FXO ports and the corresponding PBX port.

4. Connect CallFinder to DID Lines

Plug one end of the phone cable into the CallFinder's Channel 1 DID jack and the other end into an analog DID trunk line jack. The DID Line cable is included with your CallFinder.

Caution: The DID Line cable has an RJ11 connector on one end (this is the larger of the two connectors; it goes to the telephone wall receptacle). The DID Line cable has an RJ12 connector on the other end (this is the smaller connector; it goes to the DID Port on the CallFinder unit).

Never plug the DID connector into a standard POTS Line. This may damage the CallFinder or the central office equipment. Use only an analog DID Line.

Repeat for the CallFinder's Channel 2 DID port.

5. Connect CallFinder to Ethernet Network

Plug one end of your RJ45 ethernet cable into the CallFinder's ethernet jack and the other end into your network ethernet hub. This ethernet cable is not included with your CallFinder unit.

Note: Before connecting to the Ethernet Network, make sure that the network to which you are connecting the CallFinder is not a 192.168.2.x subnet.

If it is a 192.168.2.x subnet, it will clash with the CallFinder because the CallFinder's default IP address is 192.168.2.1. To remedy such a situation, connect from the Admin PC to the CallFinder using an RJ45 crossover cable until the CallFinder's IP address has been configured. Thereafter, connect the CallFinder into the network with an ordinary RJ45 cable.

6. Do Power-On Test

Test your CallFinder by turning it on (an on-off switch is located on the back panel). When you apply power, the CallFinder performs a diagnostic self-test. The Status indicator flashes when the test is complete and the unit is ready. If this does not happen, check that the power switch is on, the power supply is solidly connected, and the AC outlet is live.

Part B: Configuring the CallFinder Server

1. Collecting Configuration Data

The table below lists the information you will need to fill in on the various CallFinder Server screen.

Gathering this information in advance will expedite the CallFinder configuration process.

Server Parameters (for Server Admin screen)	Values for this CallFinder
IP Address (of FaxFinder unit)	
Subnet Mask	
(Domain) Name Server	
Secondary Name Server (optional)	
Default Gateway	
Time Server (typically time.nist.gov)	
SMTP (Mail) Server Address	

Administrative User Parameters (for Server Phonebook & Configuration (SMTP) screens and FFCF Manager's Add FaxFinder screens)					
Name	User ID/ Username	Email Address	DID #	PBX Extension	Password
<i>Administrator</i>					
<i>Unassigned Number recipient</i>					
<i>Server ID</i>					

2. Setting Admin PC to Startup IP Address

- a. Connect a pc to your network.
- b. Set the pc IP address to **192.168.2.x** subnet (using any address excluding 192.168.2.1).

<p>Windows XP</p> <ol style="list-style-type: none"> a. From the Windows desktop, right-click on “My Network Places,” and select “Properties.” b. In the Network Connection screen, right-click on “Local Area Connection.” c. In the Local Area Connection Properties screen, on the “General” tab, scroll to the “Internet Protocol (TCP/IP)” entry and select it. Click “Properties.” d. In the Internet Protocol (TCP/IP) Properties screen, record the existing IP address. Then reset the IP address to 192.168.2.2. 	<p>Windows 2000</p> <ol style="list-style-type: none"> a. From the Windows desktop, right-click on “My Network Places,” and select “Properties.” b. In the Network and Dialup Connections screen, right-click on “Local Area Connection” and select “Properties.” c. In the Local Area Connection Properties screen, select the “Internet Protocol (TCP/IP)” entry. Click “Properties.” d. In the Internet Protocol (TCP/IP) Properties screen, record the existing IP address. Then reset the IP address to 192.168.2.2.
<p>Windows NT</p> <ol style="list-style-type: none"> a. From the Windows desktop, right-click on “Network Neighborhood,” and select “Properties.” b. In the Network screen, on the “Protocols” tab, select “TCP/IP Protocol” in the list of Network Protocols. Click “Properties.” c. In the Microsoft Internet Protocol (TCP/IP) Properties screen, record the existing IP address. Then reset the IP address to 192.168.2.2. 	

3. Logging In (I)

- a. Bring up a Web browser on your PC. At the browser’s address line, type the default IP address of the CallFinder (**http://192.168.2.1**) and then press **Enter**.
- b. The **Login** screen will appear.

At this point you can be assured that the CallFinder is connected to the network.

If the **Login** screen does not appear, see item #1, “What if I can’t see the web page for my CallFinder?” in the **Troubleshooting** section (page 79).
- c. At the **Login** screen, enter **admin** (all lower case) in the User Name field.
- d. Enter **admin** (all lower case) in the Password field.
- e. Click the **Login** button. The Web Management **Home** screen will appear. From this screen, you can access all of the CallFinder software screens.

4. Setting CallFinder IP Addresses

a. In the CallFinder **Administration** screen, go to the **IP Configuration** fields.

Administration: IP Configuration			
IP Address	<input type="text" value="192.168.4.89"/>	Default Gateway	<input type="text" value="192.168.4.1"/>
Subnet Mask	<input type="text" value="255.255.255.0"/>	Secondary Name Server	<input type="text"/>
Name Server	<input type="text" value="192.168.11.251"/>		
<input type="button" value="Update"/>			

b. Fill in the IP information that applies to your CF220 CallFinder Server unit. The fields for “IP Address,” “Subnet Mask,” “Default Gateway” and “Name Server” are required. A “Secondary Name Server” may be considered optional.

c. Click **Update**. The CallFinder will adopt the new IP address 5 seconds after the Update command is invoked.

5. Resetting Admin PC to Its Regular IP Address

In step #2 above, you recorded the original IP address of the administrator’s PC and then reset it to the IP address required to allow communication with the CallFinder unit. You must now set the IP address of the administrator’s PC to a value that allows you to reach CallFinder at its new IP address.

6. Logging In (II)

Having reset the IP address of the administrator’s PC, you must log into the CallFinder software again. Go to the **Login** screen, enter **admin** as User Name and **admin** as Password.

Note: If you changed the IP address of your PC to accommodate the CallFinder, a slight complication will occur when you try to login to the CallFinder at this point. At the **Login** screen, after entering your username and password, you will be prompted to log another user out. Select “Yes.” (Clicking **Yes** cancels the logged-in status you had earlier when your PC was at its previous IP address.)

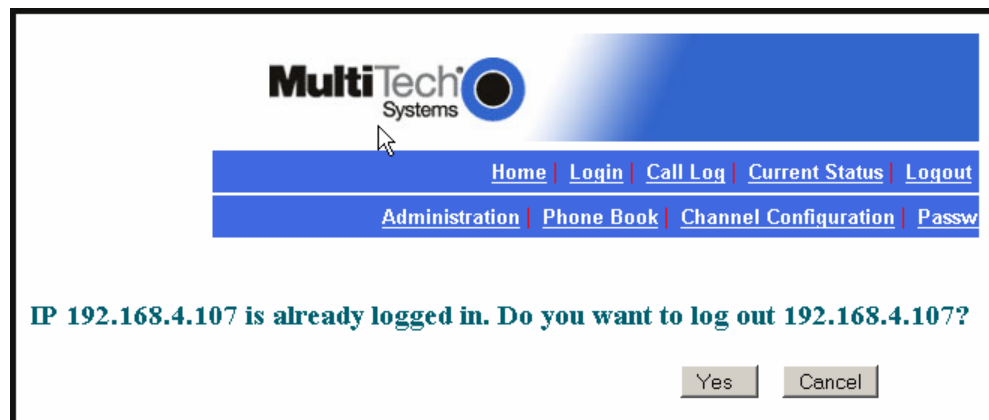

7. Setting Administrative Functions

Go to the CallFinder **Phone Book** screen.

Phone Book			
Name	DID #	Extension	Function
Administrator	2269	5000	update
OperatorLobby		0	update
Unassigned Number			
John	2262	5531	update delete
Dustin	2263	5305	update delete
Greg	2261	5515	update delete
Tracey	2265	5323	update delete
Paul	2266	5353	update delete
Rick	2268	5535	update delete
			add

a. Administrator Row: Specifying DID# and PBX Extension

- In the first row (marked Administrator) of the Phone Book screen, enter the DID number and PBX extension of the CallFinder administrator. The first row is *a/ways* for the party who performs the 'administrator' function. Even if the **Name** field of this first row is changed (which is permissible) it still pertains to the administrator function (which includes receiving call-log emails).
- Click on **Update** in the first row. The **Login** screen will re-appear. Log in again.

b. "Unassigned Number" Row: Specifying PBX Extension

- In the second row (marked "Unassigned Number" by default) of the **Phone Book** screen, enter the name and PBX Extension of the party that you want to receive calls made to unassigned DID numbers (if there are any). The second row is *a/ways* for the party who receives calls made to unassigned DID numbers. Even if the **Name** field of this second row is changed (which is permissible) it still pertains to the function of receiving calls made to unassigned numbers. All incoming calls made to activated DID numbers for which no PBX extension has been assigned will go to the party listed in the second row. (Calls involving corrupted DID numbers will also go to the Unassigned Number PBX extension.) Typically an operator (or administrator) might handle such calls. However, any name can be entered in this second row.
- Click on **Update** in the second row. The message "Success: [name] was updated" will appear above the Phone Book list.

8. Setting Up the Mail Server

The CallFinder uses a mail server to send, by email, call log reports to the administrator. An email is also sent to the administrator each time the CallFinder is powered up. In all cases, you must specify the address of the mail server and the email address of the administrator. Some email servers require authentication before allowing the CallFinder access. In these cases, the CallFinder unit must be assigned a Server User Name and a password. If the mail server does not require authentication, the bottom row of **SMTP Configuration** fields (“Server User ID,” “Password,” and “Retype Password”) must be left blank.

- a. In the CallFinder **Administration** screen, go to the **SMTP Configuration** fields.

- b. Fill in the network IP address or domain name of your mail server.
- c. Enter the email address of the administrator (the party that you want to receive call log reports).
- d. At this point the Administrator should receive an email from your CallFinder saying that the mail server address has been updated.
- e. **Email Server Authentication Parameters.** If your email server requires authentication in order to give the CallFinder access, fill in the lower three fields (**Server User ID, Password, Retype Password**). If you can enter the network email program and send messages *without* entering a User ID and Password, then you *must* leave these fields blank. However, if your network email program *does* require a User ID and Password in order to send email messages, you *must* fill in these three fields. If authentication is required and these fields are left blank, then the error “SMTP Authentication Error” will appear on the **Current Status** screen in the “Email Status” field. If authentication is not required and these fields *are* filled in, then an error will also occur. *You must know how your email server works in this regard and complete the Administration: SMTP Configuration screen accordingly.*
- f. If you do not receive an email saying that the mail server address has been updated, see item #2 “What if I don’t get an email when I set the mail server address?” in the Troubleshooting section of this manual (page 79).

9. Configuring the CallFinder's Channels

The CallFinder's channels direct inbound calls to their proper destinations.

- a. In the CallFinder software, go to the **Channel Configuration** screen.
- b. Under **Channel Configuration: Channel 1**, enter the values that match the characteristics of your DID phone line in the fields provided. Three parameters relate to the DID line coming into the CallFinder channel. Four parameters relate to the PBX extension line to which the CallFinder channel connects.

The screenshot shows the 'Channel Configuration' screen in the CallFinder software. It features a navigation bar at the top with links for Home, Login, Call Log, Current Status, Logout, and Help. Below this is a sub-navigation bar with Administration, Phone Book, and Channel Configuration. The main content area is divided into two sections: 'Channel Configuration: Channel 1' and 'Channel Configuration: Channel 2'. Each section contains the following parameters:

- Max DID Digits:** A text input field containing the value '4'.
- Extension Port:** Radio buttons for FXS and FXO, with FXO selected.
- Receive Gain:** A text input field containing the value '100'.
- Polarity:** Radio buttons for A and B, with A selected.
- DID Start:** Radio buttons for wink, immediate, and delay dial, with wink selected.
- Auto Attendant Delay:** A text input field containing the value '0' for Channel 1 and '2' for Channel 2.
- Transmit Gain:** A text input field containing the value '100'.

Each section also includes an 'update' button.

DID Line Parameters

Consult the telco supplying the DID line about these parameters. See the section "Prerequisite: Ordering the DID Lines" on page 6.

Max DID Digits: the number of digits the CallFinder will receive from the telco central office on the DID line.

DID Start: wink, immediate, or delay dial.

Polarity: This refers to the DID battery polarity. This parameter must be set on a trial-and-error basis.

Signs of incorrect polarity:

- (1) outside party originating call to DID number gets immediate busy signal after dialing;
- (2) line suddenly disconnects just when call should go through.

PBX Extension Line Parameters

Extension Port: default = FXO (prevents damage from wrongly applied battery and ring voltages)

Set as FXO when the CallFinder is to be connected to a PBX station port (a port that is normally connected to a normal analog telephone).

Set as FXS when the CallFinder is to be connected to a PBX trunk port (a port that would normally be connected to an ordinary POTS phone line from the telco central office).

Auto Attendant Delay: The Auto Attendant Delay value, x, determines how long the CallFinder will pause before dialing on the PBX.

If the CallFinder channel is configured as an FXS port it will ring the PBX and wait x seconds before dialing the proper extension after the PBX seizes the line.

Set x to be 1 or greater.

If the CallFinder channel is configured as an FXO port, x is the length of time that the CallFinder will wait before dialing after the CallFinder itself has seized the line from the PBX.

If set x to 0, the CallFinder must detect dial tone from the PBX before dialing. (The setting of 0 can be used only if the PBX presents dial tone to the CallFinder.)

Extension Mic Gain: This value adjusts the volume of the phone's microphone. Default = 8.
Increase value if outgoing audio signal is constant but low.

Decrease value if outgoing audio signal intermittently cuts out or is clipped.

This parameter is sensitive and important to system performance.

Extension Speaker Gain: This value adjusts the volume of the phone's speaker. Default = 30.

Increase value if outgoing audio signal is constant but low.

Decrease value if outgoing audio signal intermittently cuts out or is clipped.

This parameter is sensitive and important to system performance.

c. Click **Update**.

d. Click on **Current Status**. Watch the **Current Status: Channel-1/Channel-2** portion of the screen. The "State" of each DID Modem should be "Waiting for Ring."

10. Connecting CallFinder to PBX

Now that the Extension Ports have been configured (as FXS or FXO) you can connect the cables between the CallFinder's Channel 1 and Channel 2 connectors and the appropriate PBX port.

Remember:

(a) to connect a CallFinder channel to a PBX trunk port, the channel must be set to FXS;

(b) to connect a CallFinder channel to a PBX station port, the channel must be set to FXO.

11. Testing the Channel with a Call

a. From another phone (either from from another PBX extension or from an ordinary POTS phone independent of the PBX), call one of the DID phone numbers that is active in the system. Dial the DID phone number as you would from an outside line (it will not work to dial the number as if it were an ordinary 3- or 4-digit extension of the PBX).

b. In the **Current Status: DID Modem** screen, the "State" field should change to "Waiting for Connect" (briefly) and then to "Connected" (for the duration of the call) indicating that the voice connection to the assigned PBX extension has been made. (The **Current Status** screen is updated automatically each time you open the screen and every two minutes or so thereafter.)

The screenshot shows the MultiTech Systems web interface. At the top, there is a navigation menu with links: Home, Login, Call Log, Current Status, Logout, Help. Below this is another menu: Administration, Phone Book, Channel Configuration, Password Administration. The main content area is titled "Current Status: System" and displays the following information:

Current Time	Tue May 25 11:40:48 2004	Up Time	13 days, 3h:50m
Pending Messages	0	Email Status	No Errors
Time Server Status	No Errors		

Below the system status, there are two sections for Channel 1 and Channel 2:

Current Status: Channel 1

State	Connected	Connect Time	05/25/2004 11:39:58 AM	Elapsed Seconds	50 Seconds
-------	-----------	--------------	------------------------	-----------------	------------

Buttons: Initialize Channel, Make Busy

Current Status: Channel 2

State	Waiting For Ring	Connect Time		Elapsed Seconds	
-------	------------------	--------------	--	-----------------	--

Buttons: Initialize Channel, Make Busy

c. If you observe both the "Connected" state and verify the presence of voice, then the CallFinder's Channel has been configured properly.

If either of these is absent, see item #3 "What if the CallFinder channel doesn't answer a call on the DID line?" in the **Troubleshooting** section of this manual (page 81).

12. Changing Administrator's Password for CallFinder SW

- a. In the **Password Administration** screen, enter a new User ID and Password for the CallFinder Administrator (something other than “admin” and “admin”). This User ID and password are used to give the administrator access to the CallFinder's built-in software. Re-enter the password in the “Confirm Password” field. Passwords can be as short as 1 character, as long as 40 characters, and are case-sensitive.

Password Administration				
Name	User ID	Password	Confirm Password	Function
AdminPete Unassigned Number	AdminPeteSmith	*****	*****	update

- b. Click **Update** for this row. The **Login** screen will appear.

13. Assigning DID Numbers to PBX Users (Extensions)

- a. In the **Phone Book** screen just below the entries for the CallFinder administrator, make phonebook entries for the other persons in your office to whom DID numbers have been assigned.

For each such DID user, enter the name, DID number (the digits that the DID line will be sending to the CallFinder to reach this user), and PBX extension (the number that the CallFinder must dial on the PBX to reach the user) in the appropriate fields.

- b. Click on **Add** for each row completed. The message “Success: [name] was updated” will appear above the Phone Book list.

Phone Book			
Name	DID #	Extension	Function
Administrator	2269	5000	update
OperatorLobby Unassigned Number		0	update
John	2262	5531	update delete
Dustin	2263	5305	update delete
Greg	2261	5515	update delete
Tracey	2265	5323	update delete
Paul	2266	5353	update delete
Rick	2268	5535	update delete
			add

Chapter 4 – CallFinder Software Screens

In this chapter, we present the screens of the CallFinder software. We describe each field in each screen and some of the command buttons. (We do not describe command buttons that have functions that would be readily understood by users of Windows software. Examples of such self-evident functions include buttons like “OK,” “Cancel,” “Next,” etc.)

Home Screen

The CallFinder **Home** screen offers access to all other CallFinder software screens.



Login Screen

The CallFinder Server **Login** screen is the primary security device for the Server software.

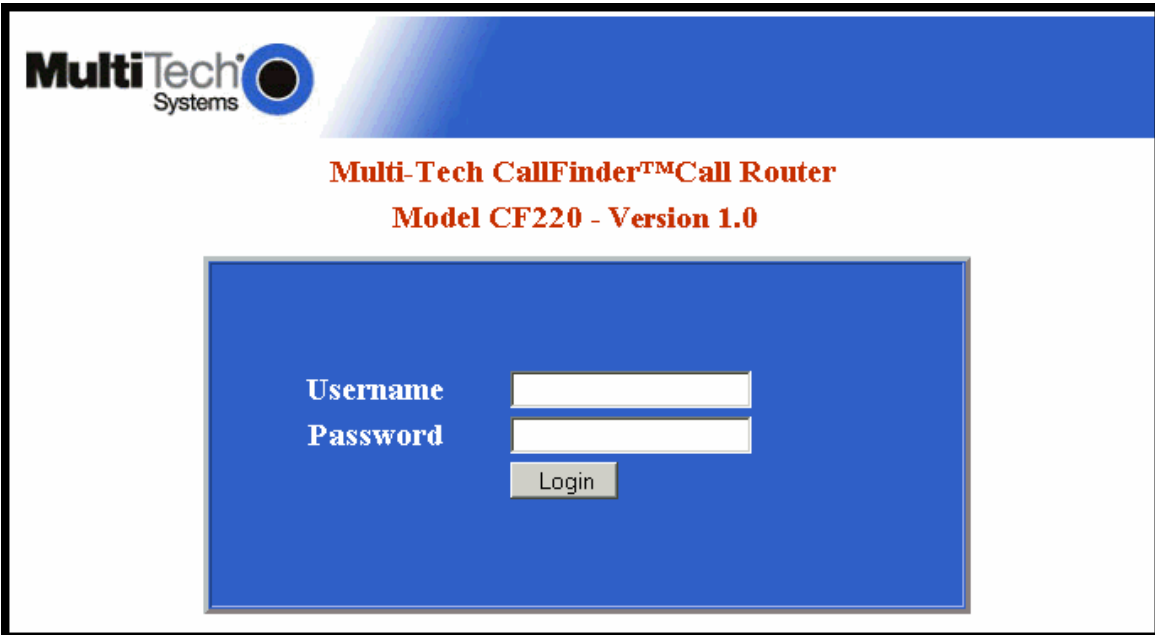

The CallFinder has a default setting that allows use of “admin” as both the User Name and the Password at initial startup. After you have begun configuring your CallFinder unit, you should change the password in the **Password Administration** screen described later in this chapter.

If you try to log in while another party with Administrator is logged in, a confirmation screen lets you decide whether or not to log in *in place of* that party. Remember: when you log in, that other party will be logged out. (Only one party can be logged in at a time.)

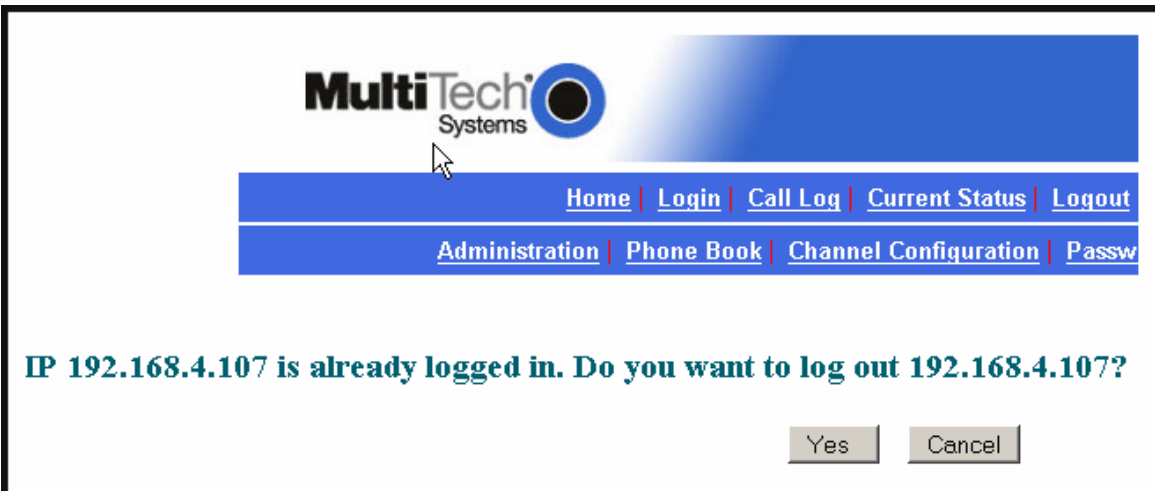

Call Log Screen

Call Log		
Time	Name	Duration
05/18/2004 04:16:53 PM	Peg Manson	53 seconds
05/18/2004 04:13:05 PM	Hans Pegosond	47 seconds
05/18/2004 04:12:47 PM	Meg Garner	9 seconds
05/18/2004 04:12:19 PM	Hans Pegosond	23 seconds
05/18/2004 04:07:49 PM	Meg Garner	58 seconds

Call Log Screen Field Definitions		
Column	Values	Description
Time	mm/dd/yyyy + hh/mm/ss + am/pm dd/mm/yyyy + hh/mm/ss + am/pm yyyy/mm/dd + hh/mm/ss + am/pm	Date and time at which call was received.
Name	alphanumeric	Party receiving call.
Duration	<i>mmm</i> minutes <i>ss</i> seconds	How long the call lasted.

Current Status Screen

MultiTech Systems

[Home](#) | [Login](#) | [Call Log](#) | [Current Status](#) | [Logout](#) | [Help](#)

[Administration](#) | [Phone Book](#) | [Channel Configuration](#) | [Password Administration](#)

Current Status: System

Current Time	Tue May 25 11:40:48 2004	Up Time	13 days, 3h:50m
Pending Messages	0	Email Status	No Errors
Time Server Status	No Errors		

Current Status: Channel 1

State	Connected	Connect Time	05/25/2004 11:39:58 AM	Elapsed Seconds	50 Seconds
--------------	-----------	---------------------	------------------------	------------------------	------------

Current Status: Channel 2

State	Waiting For Ring	Connect Time		Elapsed Seconds	
--------------	------------------	---------------------	--	------------------------	--

Current Status Screen Field Definitions		
Field Name	Values	Description
System fields group		
Current Time	weekday, mo, dd hh:mm:ss yyyy	The present time of day.
Pending Msgs	numeric	Emails that have arrived in the CallFinder unit that have not yet been conveyed to clients. These include administrative emails of several kinds: call log messages, debug log messages, call error messages, mail server change notification message (relating to the "SMTP Server Address" field of Administration screen), reboot message indicating that the CallFinder is online.
Time Server Status	Initializing, No Errors, SNTP Error: <i>type</i>	The CallFinder synchronizes its call time stamps to an Internet source, usually a government standards site. It will attempt contact with the standards web site 5 times in 20 seconds. If contact fails, it will try 5 times again 5 minutes later. If contact succeeds, the FaxFinder will update its stamping time periodically per an interval set in the Administration screen.

Current Status Screen Field Definitions (cont'd)		
Field Name	Values	Description
System fields group		
Up Time	x days yy hours: zz minutes	Operation time since last reboot.
Email Status	No Errors, Bad MailServer Address, Mail Server Connect Failed, SMTP Invalid Response, SMTP Client Timeout	Indicates whether or not the CallFinder can communicate properly with an email server.
Channel 1 & 2 fields group		
State	Waiting for Ring, Initializing Modem, Waiting for Connect, Connected Busied Out	Indicates the current operating condition of the CallFinder's channel (Channel 1 or 2).
Connect Time	mm/dd/yyyy, hh:mm:ss	For the current call, the date and time at which the connection began.
Elapsed Seconds	numeric	The duration of the current call in seconds.
Initialize Channel (button)		Initializes the modem, clearing a busied-out state.
Make Busy (button)		Imposes a busied state on the channel.

Logout Option

When you click on Logout in the CallFinder **Home** screen, you will be logged out of the CallFinder software. The **Login** screen will appear to allow access to re-enter the program.

Help Screen

Online Help has not yet been implemented.

Administration Screen

[Home](#) | [Login](#) | [Call Log](#) | [Current Status](#) | [Logout](#) | [Help](#)

[Administration](#) | [Phone Book](#) | [Channel Configuration](#) | [Password Administration](#)

Administration:IP Configuration

IP Address

Subnet Mask Default Gateway

Name Server Secondary Name Server

Administration:SMTP Configuration

SMTP Server Address Administrator E-mail

Server User ID Password Retype Password

Administration:Time Configuration

Time Server

Add Time Server

Request Interval Days Hours Minutes

Time Zone

Date Format

Time Format

Administration Screen Field Definitions		
Field Name	Values	Description
IP Configuration Fields		
IP Address	n.n.n.n for n = 0-255	The IP address of the CallFinder.
Subnet Mask	n.n.n.n for n = 0-255	This subnet mask is the subnet for the network to which the CallFinder is connected. A subnet mask is used in conjunction with the IP address to determine if a data destination is on the same immediate network or not (in the case of networks made of hubs and ethernet cards). The default value, often used, is 255.255.255.0.
Name Server	n.n.n.n for n = 0-255	The IP address of a local DNS server.
Default Gateway Name	n.n.n.n for n = 0-255	Address used to route data out of the immediate network.
Secondary Name Server	n.n.n.n for n = 0-255	The IP address of a backup DNS server, which is typically at a separate location.
Update (button)		Click on this button to make changes to IP Configuration fields take effect.

Administration Screen Field Definitions		
Field Name	Values	Description
SMTP Configuration Fields		
SMTP Server Address	n.n.n.n for n = 0-255	Domain name or IP address for mail server (SMTP must be supported on mail server).
Server User ID	alphanumeric	Identifier used by CallFinder when interfacing with mail server. CallFinder uses mail server to send call reports to administrator. Some email servers require authentication when accessed for this purpose. To satisfy this authentication requirement (where needed), a User ID must be specified for the CallFinder unit. Leave this field blank if authentication is not needed.
Administrator Email	alphanumeric	Email address to which call log reports will be sent. An email is also sent to the administrator each time the CallFinder is powered up and when mail configuration settings are updated.
Password	alphanumeric	Password used by CallFinder server unit when accessing mail server. Leave this field blank if authentication is not needed.
Retype Password	alphanumeric	Reiteration of above password.
Update (button)		Click on this button to make changes to SMTP Configuration take effect. Updating triggers the sending of an email to the administrator.
Time Configuration Fields		
Time Server	URL	Location of time-tracking computer that supports SNTP. This server is the functional substitute for a real-time clock in the CallFinder unit. Clock sources can be found on the Internet. In the absence of an Internet connection, a time source within the CallFinder network must be established. The clock is used for call logging.
Add Time Server	URL	Used to add a user-supplied time server.
Time Zone	alphanumeric	Indicates the time zone in which the CallFinder unit is located.

Administration Screen Field Definitions (continued)		
Field Name	Values	Description
Time Configuration Fields (continued)		
Request Interval		This value (to be set by user) indicates how often the CallFinder will update its clock from the Time Server.
Update (button)		Click on this button to make changes to Time Configuration settings take effect.
Date Format	mm/dd/yyyy, OR dd/mm/yyyy, OR yyyy/mm/dd	The date can be set to one of three orders, where mm is the month, dd is the day of the month, and yyyy is the year.
Time Format	12-hour or 24-hour	Indicates whether time is presented in a 12-hour scheme with an am/pm designation or in a 24-hour scheme.

Phone Book Screen

The **Phone Book** screen maps the PBX extension phone numbers of clients to their respective external DID numbers.

Phone Book			
Name	DID #	Extension	Function
Administrator	2269	5000	update
OperatorLobby Unassigned Number		0	update
John	2262	5531	update delete
Dustin	2263	5305	update delete
Greg	2261	5515	update delete
Tracey	2265	5323	update delete
Paul	2266	5353	update delete
Rick	2268	5535	update delete
			add

Phone Book Screen Field Definitions		
Field Name	Values	Description
Name column	alphanumeric	For each client entry, this column shows the client's name.
DID Number column	alphanumeric	The DID number assigned to the user named in this row. This is the phone number at which this user can be reached by direct dialing because of the CallFinder's inbound routing functionality. Typically, these DID numbers are three-digit or four-digit numbers. The quantity of these DID phone numbers available from a single DID line depends on the telco. Telcos commonly offer DID service by allotting twenty DID numbers to a single DID phone line. However, other line quantities may be offered.
Extension column	numeric	The PBX extension to which calls to the listed DID number will be directed.
Function column	Buttons for Update, Delete, and Add functions	For each user entry, this column presents functions that can be invoked upon the entry.

Phone Book Screen Field Definitions (cont'd)		
Field Name	Values	Description
First row	alphanumeric	Administrator row. NOTE: This first row can be renamed as desired. However, its function will always remain the same: it is the party who serves as administrator for the CallFinder system. <i>Do not enter the Name and DID number of an ordinary user in this field.</i>
Second row (with default label "Unassigned Number")	alphanumeric	Ideally, a PBX extension is assigned to every available DID number. If, however, there are DID phone numbers to which no PBX extension has been assigned, calls to these unassigned numbers will go to the destination specified in this field. (Calls involving corrupted DID numbers also go to the party handling the Unassigned Number function.) Such calls might reasonably go either to the extension of a receptionist/switchboard-operator or to an extension that plays a recorded message. NOTE: This second row can be renamed as desired. However, its function will always remain the same: it is the destination for calls to DID numbers to which no PBX extension has been assigned. <i>Do not enter the Name and DID number of an ordinary user in this field.</i>

Channel Configuration Screen

"Channel Configuration: Channel 1 & Channel 2" Screen Field Definitions		
Field Name	Values	Description
Max DID Digits	1-7	The number of digits that the telco supplies to the DID line when an incoming call is received. Default = 4.
Extension Port	FXS or FXO	Denotes the interface type of the port (Channel 1 or Channel 2). Each CallFinder port can be set up either as an FXS port or as an FXO port. If a port is configured as FXS, it would commonly be connected to a PBX trunk line. If a port is configured as FXO, it would commonly be connected to a PBX station line.
Extension Mic Gain	0 to 255	The degree of amplification that the CallFinder imposes on the voice signal of the phone receiving the DID call. Default = 8 NOTE: <i>This is a very sensitive parameter. Change it only if necessary and then very carefully. Misadjustment of this parameter can cause unacceptable degradation of performance.</i>
Polarity	A or B	Orientation of DID battery voltage. Polarity of the battery voltage on the DID line is very important for the DID line to work properly. Since the line comes from the telco as a twisted pair the required polarity can only be determined through trial and error. The modem is defaulted to Polarity A. If an immediate busy signal is received when dialing a DID number or if the call is dropped shortly after connecting, then the battery polarity is probably wrong and the alternate battery voltage should be tried. Default = A.
DID Start	wink, immediate, delay dial	Indicates the signaling method that the DID line uses to indicate readiness to receive digits. The telco must specify which 'start type' is to be used. For Wink Start , the CallFinder detects the off-hook condition. Then the CallFinder reverses battery polarity for a specified time (140-290 ms; a "wink") and then becomes ready to receive DTMF digits. For Immediate Start , the CallFinder detects the off-hook condition initiated by the telco central-office call and becomes ready to receive DTMF digits immediately. For Delay Dial , the CallFinder detects the off-hook condition. Then the CallFinder reverses battery polarity for a specified time (reverse polarity duration has wider acceptable range than for Wink Start) and then becomes ready to receive DTMF digits.

“Channel Configuration: Channel 1 & Channel 2” Screen Field Definitions (cont’d)		
Field Name	Values	Description
Auto Attendant Delay	n= 0, n= 1-255 in seconds	<p>The CallFinder receives calls on the DID line and then passes them on to the PBX. Some PBXs have an auto-attendant for directing calls to PBX extensions. When the CallFinder directs an incoming call to the PBX it must sometimes wait some duration for a PBX auto-attendant before dialing the extension. The Auto Attendant Delay parameter specifies the length of time that the CallFinder will wait for the auto attendant in this context.</p> <p>For FXS. The CallFinder rings the PBX. The PBX seizes the line. The CallFinder waits n seconds before dialing the proper PBX extension. Use a value of n = 1 second or more. Default = 2</p> <p>For FXO. The CallFinder seizes the line from the PBX. If Auto Attendant Delay value is set to zero (n= 0), then the CallFinder will listen for dial tone on the PBX extension line and begin dialing the extension as soon as dial tone is detected. If n > 0, then the CallFinder waits n seconds before dialing. Default= 0</p>
Extension Speaker Gain	0 - 255	<p>The degree of amplification that the CallFinder imposes on the FXS/FXO receive level. Default = 30</p> <p>NOTE: <i>This is a very sensitive parameter. In general, you should not need to change it. Change this parameter only if necessary and then very carefully to remedy audio quality problems. Misadjustment of this parameter can cause unacceptable degradation of performance.</i></p>
Update (button)		Click on this button to save and activate the changes to the channel configuration.

Password Administration Screen

The CallFinder software admits only one user, the administrator. As shipped, the administrator's Username (User ID) is "admin" and the administrator's password is also "admin." You can use the **Password Administration** screen to change the administrative password parameters.

Password Administration				
Name	User ID	Password	Confirm Password	Function
AdminPeteSmith Administrator	AdminPete	*****	*****	update

"Password Administration" Screen Field Definitions		
Field Name	Values	Description
Name	"Administrator" or user-specified descriptor for party handling administrative functions	Identifies party with administrative rights to configure and control the CallFinder server unit. This party will generally receive call log reports.
User ID	"admin" or user-specified User-ID descriptor for administrator	User ID of administrator. Default = admin
Password	alphanumeric; user-specified PW has 2 to 40 characters	The alpha-numeric string used to prevent unauthorized access to the CallFinder software. Password is case sensitive. default= "admin"
Confirm Password	alphanumeric	After the password has been entered in the preceding field, it must be entered verbatim a second time here. This second entry prevents the problem of establishing a non-reproducible password by inadvertently hitting a wrong key when establishing the password.
Function	update button	Pressing Update saves the password-related information as part of the CallFinder's configuration data.

Chapter 5 – CallFinder Server Operation

Front Panel LEDs

Label Identifier	Name	Description
General LEDs		
	Power	On if unit is on.
	Status	Flashing Green = unit is functioning properly Solid Red = unit is having its software updated. DO NOT TURN OFF if Status LED is solid red. Off = system is booting or power is off
Line 1 LED		
		Presents status of Channel 1.
TD	Transmit Data	Channel 1 is being configured.
RD	Receive Data	Channel 1 is reporting.
TR	Terminal Ready	When lit, channel 2 is ready to receive a call. Lit when DTR to DID modem is high.
DID	DID	The telco central office is drawing power from the DID line which means that a call is in progress.
Line 2 LEDs		
		Presents status of channel 2.
TD	Transmit Data	Channel 2 is being configured.
RD	Receive Data	Channel 2 is reporting.
TR	Terminal Ready	When lit, channel 2 is ready to receive a call. Lit when DTR to DID modem is high.
DID	DID	The telco central office is drawing power from the DID line which means that a call is in progress.
Ethernet LEDs		
ACT	Activity	Lit when packets are being transmitted by any device on the Ethernet network (not necessarily by the CallFinder).
LINK	Data Link	Lit when a physical link has been established with the Ethernet network.
SPEED	Data Rate	Indicates speed of Ethernet connection. If lit, data rate is 100 Mb/sec; if not lit, data rate is 10 Mb/sec.

Updating CallFinder Firmware

Successive editions of CallFinder firmware will be issued over time. There are two kinds of CallFinder firmware: (1) server firmware, and (2) firmware used by the DID-channel modems. When issued, such updated firmware files will be accessible on the MultiTech web site. However, updating is done by the FaxFinder/CallFinder Manager software. To install updated firmware, see “Updating Firmware” in *Chapter 7: FFCF Manager Operation*.

Call Log Email Messages

The CallFinder keeps track of the calls it handles. In a call log file, the CallFinder records who called, when, for how long, which DID number the call came in on, and which extension the call was completed to. The CallFinder sends the call log file to the administrator as an email attachment.

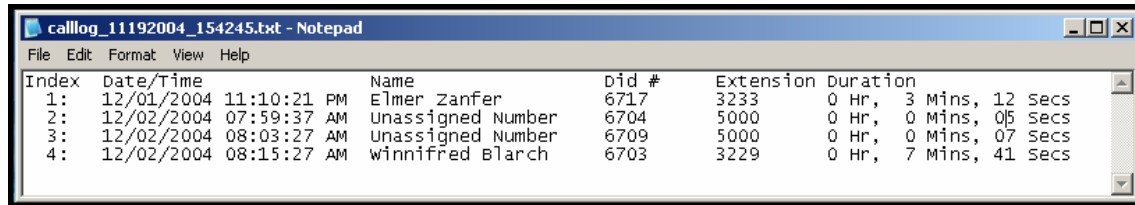

Index	Date/Time	Name	Did #	Extension	Duration
1:	12/01/2004 11:10:21 PM	Elmer Zanfer	6717	3233	0 Hr, 3 Mins, 12 Secs
2:	12/02/2004 07:59:37 AM	Unassigned Number	6704	5000	0 Hr, 0 Mins, 05 Secs
3:	12/02/2004 08:03:27 AM	Unassigned Number	6709	5000	0 Hr, 0 Mins, 07 Secs
4:	12/02/2004 08:15:27 AM	winnifred Blarch	6703	3229	0 Hr, 7 Mins, 41 Secs

Initializing and Busing DID Channel Modems

The state of each DID channel modem is indicated in the **Current Status** screen.

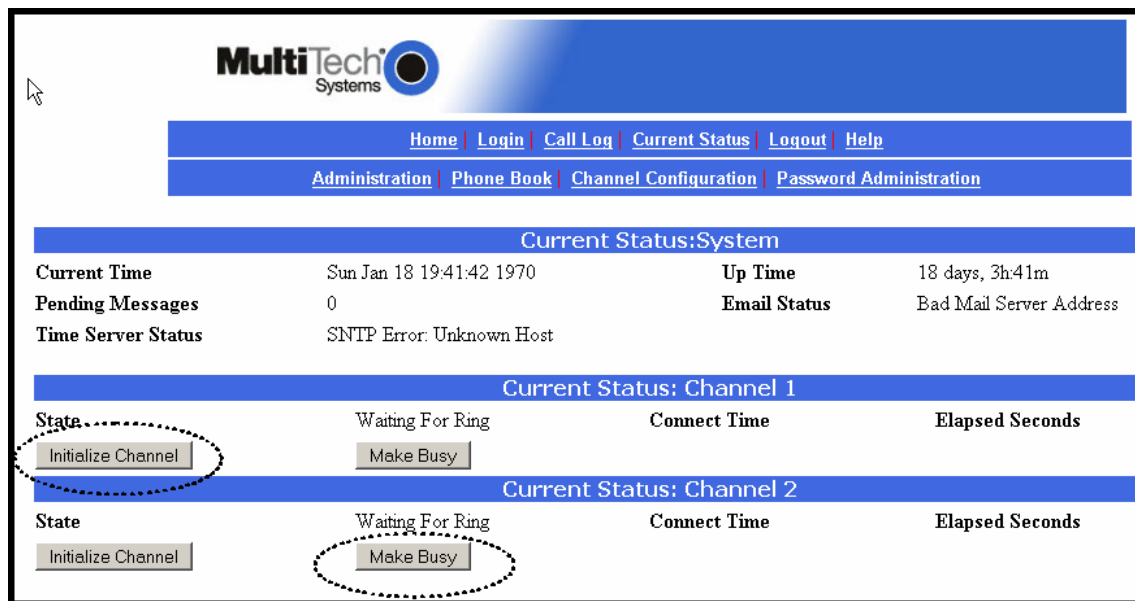

MultiTech Systems

Home | Login | Call Log | **Current Status** | Logout | Help

Administration | Phone Book | Channel Configuration | Password Administration

Current Status: System

Current Time	Sun Jan 18 19:41:42 1970	Up Time	18 days, 3h:41m
Pending Messages	0	Email Status	Bad Mail Server Address
Time Server Status	SNTP Error: Unknown Host		

Current Status: Channel 1

State	Waiting For Ring	Connect Time	Elapsed Seconds
Initialize Channel	Make Busy		

Current Status: Channel 2

State	Waiting For Ring	Connect Time	Elapsed Seconds
Initialize Channel	Make Busy		

If the **State** field value for a DID channel does not correspond to the known actual situation (for example, **State** value says “Connected” when no calls are in progress) then the “Initialize Modem” command can be used to clear the modem and return it to a ‘ready’ state (Waiting for Ring).

Note: After the Initialize Modem command has been invoked, it may take up to 2 minutes for this new status (Waiting for Ring) to appear on the screen. To see the new state sooner, click on **Current Status**.

For service, testing, or other purposes, it may be useful to keep a modem in a **Busied Out** state for a period of time. To cancel the busy state and return the modem to a ‘ready’ state (Waiting for Ring), use the “Initialize Modem” command.

The “Initialize Modem” command will end a call in progress.

Chapter 6 - FFCF Manager Installation

Introduction

The FaxFinder/CallFinder Manager software is a separate program that allows you to control and configure multiple CallFinder units in one place. The program is shipped with the CallFinder unit and must be installed on a PC connected to the same Ethernet network as all CallFinder units that it controls. This software lets you add CallFinder units to the system and synchronize phonebooks so that long lists of user names need only be entered once (and not again on each CallFinder unit added to the system). The FFCF Manager software also lets you save and restore a group of configuration settings for the CallFinder and allows you to update the CallFinder's firmware.

Installing FFCF Manager Software

The process of installing the FFCF software is explained in the illustration below.

Install Software >
View Manuals >
Requires Adobe Acrobat Reader
Install Acrobat Reader >

Insert CallFinder CD.
Installation wizard starts automatically.
Click **Install Software**.

FaxFinder CallFinder Manager - InstallShield Wizard
Preparing Setup
Please wait while the InstallShield Wizard prepares the setup.
FaxFinder CallFinder Manager Setup is preparing the InstallShield Wizard, which will guide you through the rest of the setup process. Please wait.

Transient screen appears while files are being copied.

Multi-Tech Systems FaxFinder/CallFinder Manager
Welcome to the InstallShield Wizard for FaxFinder CallFinder Manager
The InstallShield® Wizard will install FaxFinder CallFinder Manager on your computer. To continue, click Next.

Click **Next**.

Choose Destination Location
Select folder where setup will install files.
Install FaxFinder CallFinder Manager to:
C:\...\FaxFinder CallFinder Manager

Accept default or choose other file location.
Click **Next**.

Ready to Install the Program
The wizard is ready to begin installation.
Click Install to begin the installation.
If you want to review or change any of your installation settings, click Back. Click Cancel to exit the wizard.

Click **Install**.

Setup Status
FaxFinder CallFinder Manager Setup is performing the requested operations.

Transient screen appears during main installation process.

InstallShield Wizard Complete
The InstallShield Wizard has successfully installed FaxFinder CallFinder Manager. Click Finish to exit the wizard.

Click **Finish**.

Uninstalling or Reinstalling the FFCF Manager Software

1. Go to **Start | Settings | Control Panel | Add or Remove Programs**. (The menu director location of the 'Add/Remove Programs' function varies for different types of Windows operating systems.)

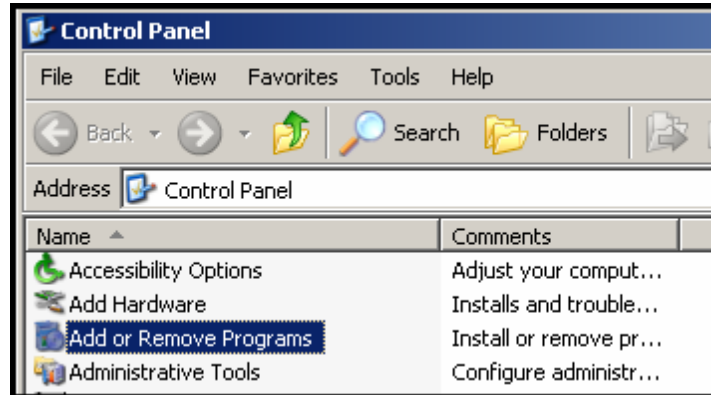

2. Select the FaxFinder CallFinder Manager program and click **Remove**.

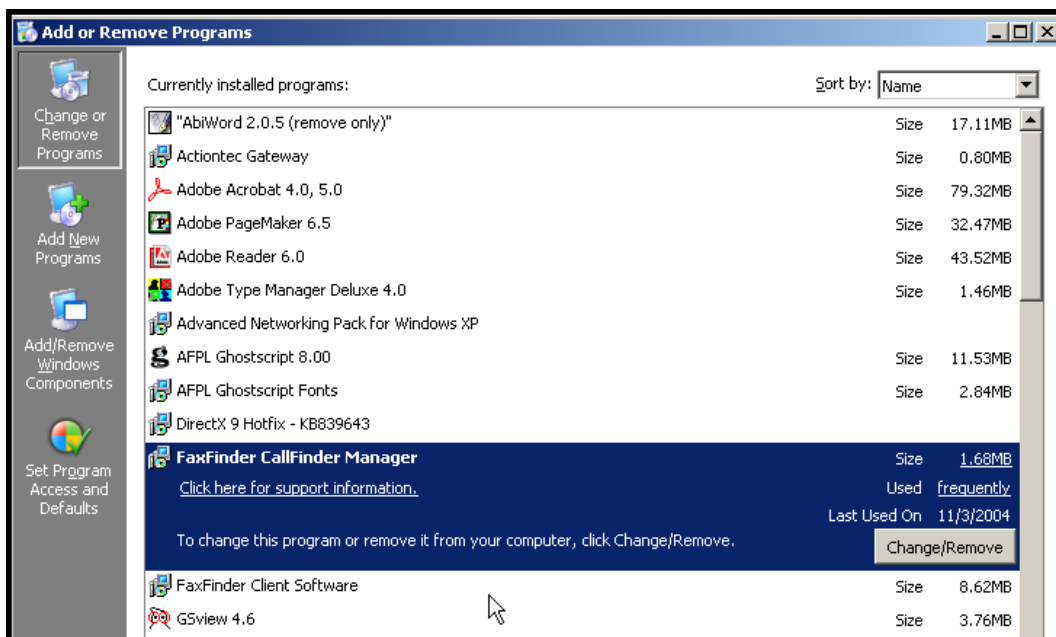

3. A transient screen will appear while the 'wizard' program prepares to un-install the software.

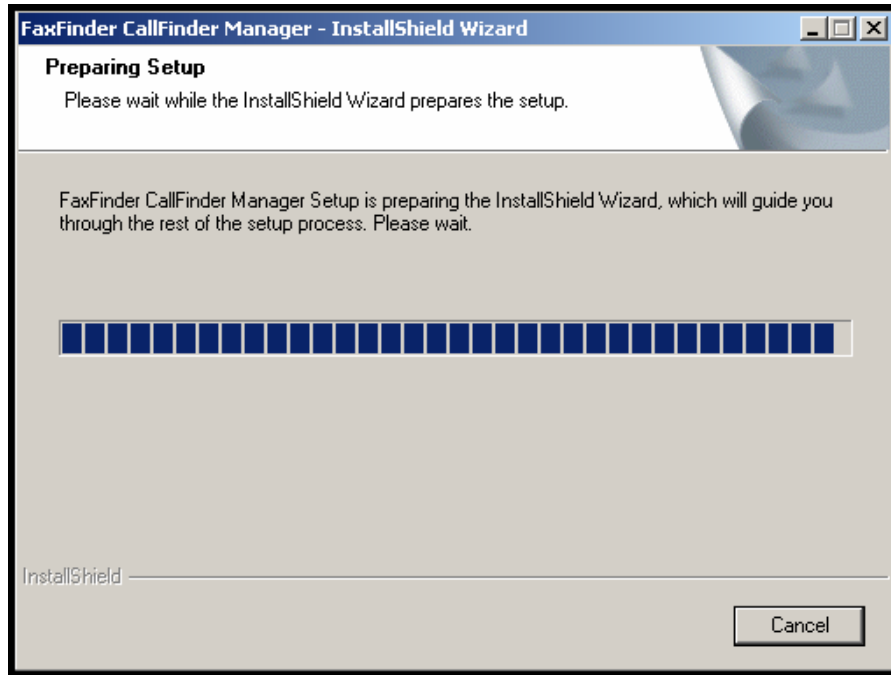

4. At the 'Welcome' screen, select "Remove" to uninstall the FFCF Manager software or select "Repair" (or "Modify") as needed to re-install or alter the existing installation of the software.

Then click **Next**.

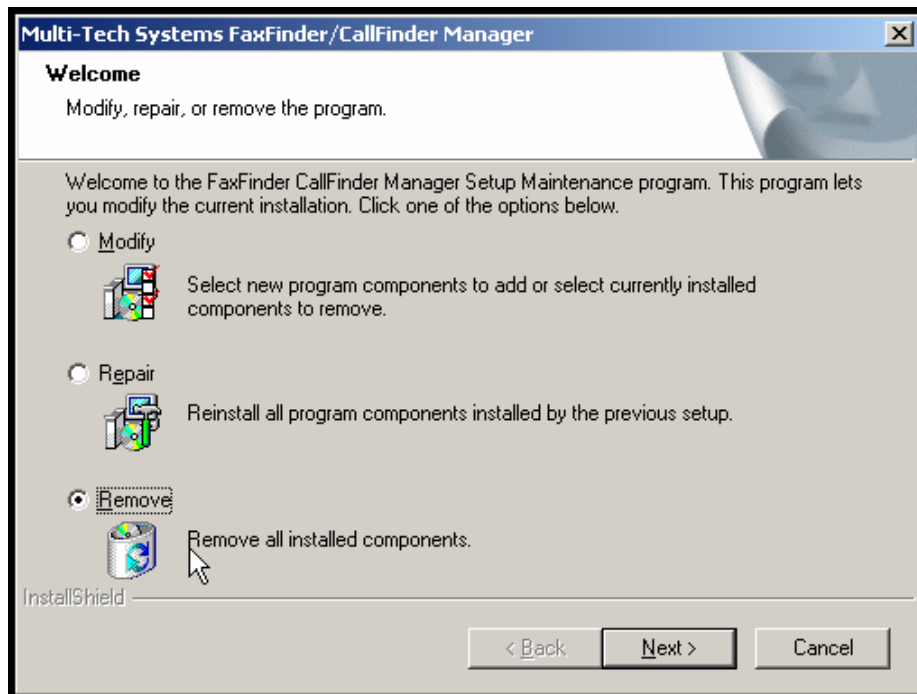

5. At the next screen, confirm your decision to uninstall the FFCF Manager software by clicking **Yes**.



6. A transient screen appears while files are being removed.

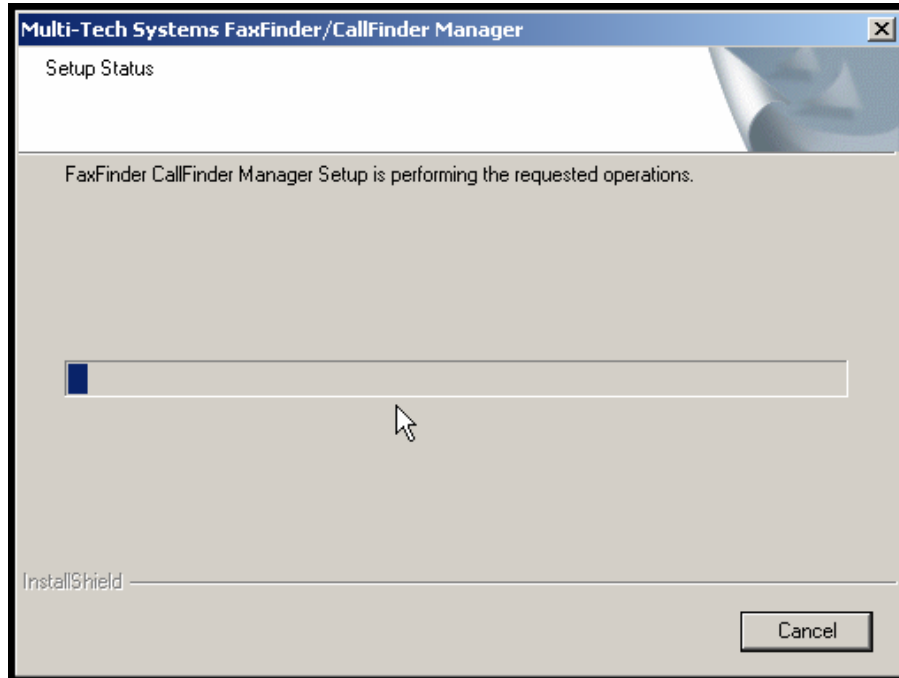

7. At the 'completion' screen, click **Finish**.

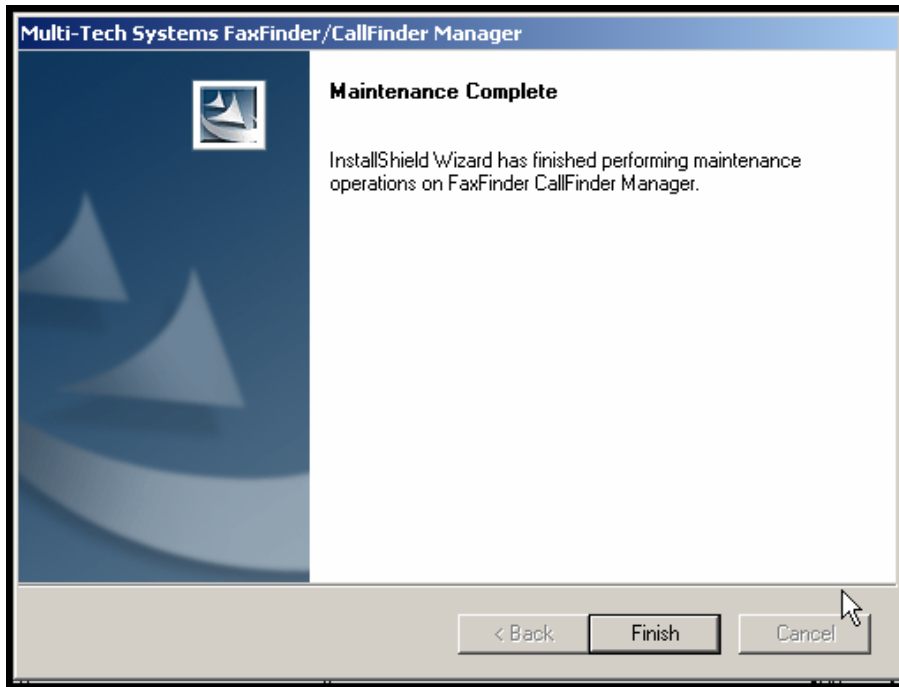

Chapter 7 - FFCF Manager Operation

Introduction

The commands of the **FFCF Manager** software are accessible in the program's pulldown **Edit** menu, and through a right-click menu that becomes available when a particular CallFinder is selected in the program's main screen.

FFCF Manager Command Summary

How to Access Command	Command Name	Summary
Edit Menu	Synchronize Phonebooks	Copies main phonebook into other CallFinder units.
	Add CallFinder	Makes another CallFinder unit part of the system.
Right-Click on CallFinder Unit	Delete CallFinder	Removes a CallFinder unit from the system.
	Save Configuration	Saves a group of telephony and IP settings for a CallFinder unit.
	Restore Configuration	Re-installs a previously saved group of telephony & IP settings into a CallFinder unit.
	Update [Firmware]	Updates CallFinder's "server" firmware and its channel firmware.
	Set Phonebook Sharing	Determines whether a CallFinder unit in a system has the main phonebook, receives a copy of the phonebook, or operates independently.
	[View] Properties	Shows IP address and Username of CallFinder unit.

Opening the FFCF Manager Software

1. To launch the FFCF Manager program from the Windows desktop, go to **Start | Programs | FaxFinder/CallFinder Manager | FaxFinder/CallFinder Manager**.

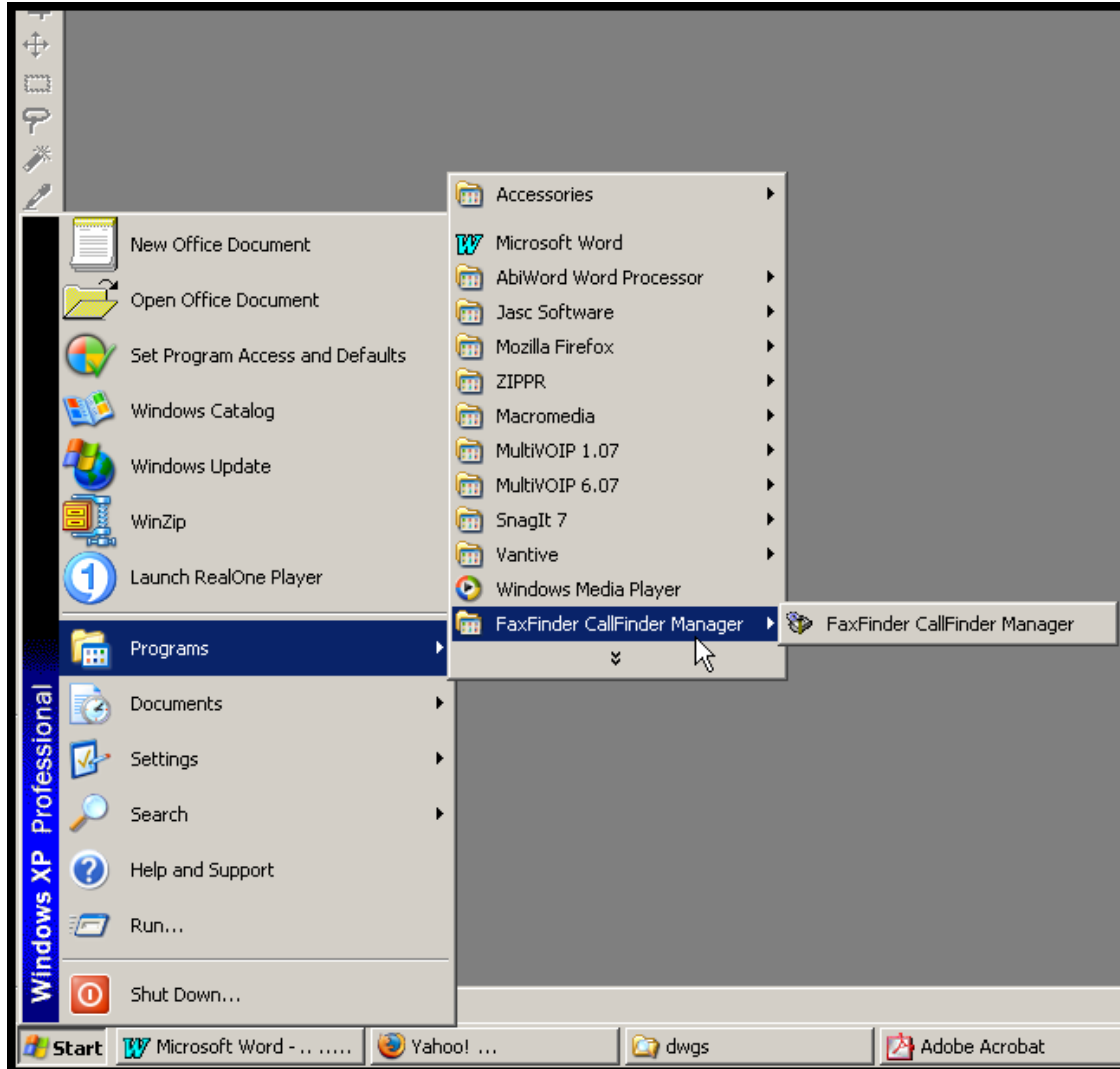

2. The FFCF Manager main screen will appear.

FFCF Manager Main Screen

The FFCF Manager's main screen lists the CallFinder units that are working together as a system. The system generally can consist of one CallFinder functioning as a master or server unit (designated as **Primary**) and one or more CallFinders functioning as client or slave units (designated as **Copy**). CallFinder units functioning without reliance on a server unit (designated as **Independent**) can also be part of the system. The FFCF Manager is in contact with all the CallFinder units of its system through the Ethernet network (Internet or private IP network) to which all are connected.

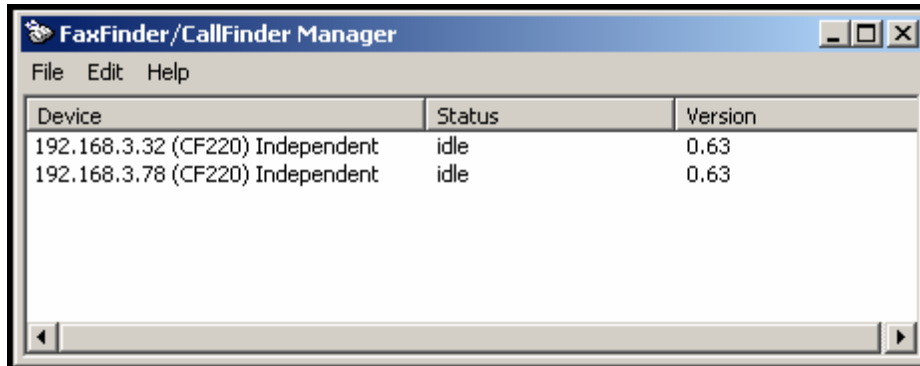

The screenshot shows a window titled "FaxFinder/CallFinder Manager" with a menu bar containing "File", "Edit", and "Help". Below the menu bar is a table with three columns: "Device", "Status", and "Version". The table contains two rows of data.

Device	Status	Version
192.168.3.32 (CF220) Independent	idle	0.63
192.168.3.78 (CF220) Independent	idle	0.63

Main Screen Menu or Column	Description
File menu	Contains the Exit command which closes the FFCF Manager program.
Edit menu	Allows you to add a CallFinder unit to the system and synchronize phonebooks from Primary CallFinder units to Copy CallFinder units within the system.
Help menu	Online help is not currently supported. See manuals.
Device column	Lists the CallFinder units in the system indicating the IP address, model number, and phonebook sharing status for each.
Status column	<p>Indicates the current operating condition of the FFCF Manager software with respect to the CallFinder unit.</p> <p>Possible states are:</p> <p>not logged in: FFCF Mgr software is not logged into CF;</p> <p>logging in: FFCF Mgr software is in process of logging into CF;</p> <p>idle: status during normal CF operation;</p> <p>updating FaxFinder/CallFinder: new version of firmware is being loaded onto the CallFinder server unit;</p> <p>updating modem: new version of firmware is being loaded onto the DID modem channel of the CallFinder server unit;</p> <p>login failure – device busy: appears when the FFCF Manager software tries to log into the CallFinder while it is handling a call.</p> <p>login failure – device not found: appears when CallFinder server cannot be contacted by FFCF Manager.</p>
Version column	Indicates the version of CallFinder server software operating on the CallFinder unit.

FFCF Manager “Edit” Menu

Edit Menu Command	Description
Synchronize Phonebooks	<p>Transfers phonebook data from a Primary CallFinder unit to all CallFinders designated as Copy units. The phonebook sharing statuses of the CallFinders (Primary, Copy, or Independent) involved must be set in advance. That is, one CallFinder must be set as the Primary unit. One or more other CallFinders must be set as Copy units designated to accept phonebook data from that particular Primary CallFinder.</p> <p>Independent CallFinders may be in the system but they do not participate in phonebook sharing.</p> <p>During synchronization, administrative phonebook parameters are not copied. In this way, the Copy units retain their entries for Unassigned Number, Administrator Password, and other parameters that must remain unique to each CallFinder unit.</p> <p>When the Synchronize Phonebooks command is invoked, the Primary unit copies its phonebook data into each Copy unit, one at a time, in sequence until all Copy units have received the data. Control screens appear before each Copy unit receives its download and the download can be canceled for any particular Copy unit.</p>
Add FaxFinder/CallFinder	<p>Brings up the Add FaxFinder/CallFinder Address screen. On this ‘Add’ screen, you enter the IP address, User Name, and Password of CallFinder units to be included in your system.</p>

Synchronizing Phonebooks

When CallFinder phonebooks are synchronized, all non-administrative listings match. One CallFinder unit (the **Primary** unit) holds the master list that is transmitted (using the **Synchronize Phonebooks** command) to other CallFinder units in the system (**Copy** units). CallFinder units can operate in same system but have independent phonebooks, in which case they are designated **Independent**.

Synchronizing phonebooks entails three steps:

1. *Designating one CallFinder as the master phone book.* In the main **FFCF Manager** screen, right-click on the unit to be designated as master, scroll to **Set Phone Book Sharing**, and select **Primary**.

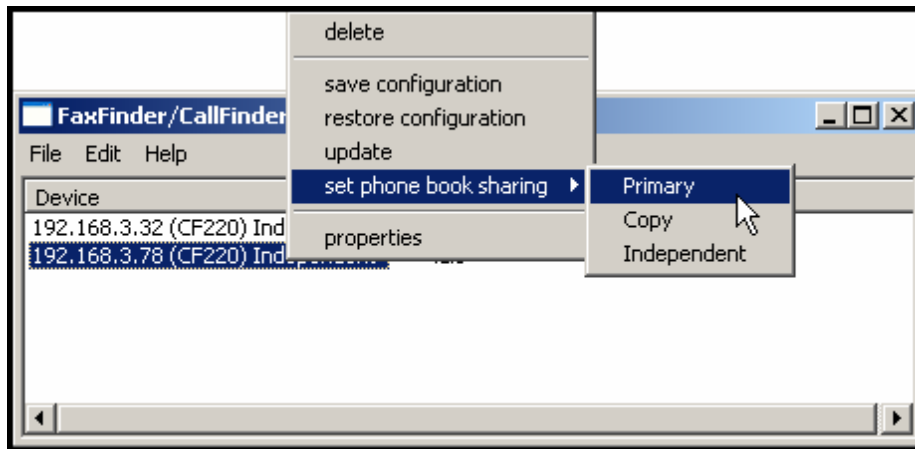

2. *Designating all other CallFinder units participating in phonebook sharing as **Copy** units.* In the main **FFCF Manager** screen, right-click on each unit to share the master phonebook, and select **Copy**.

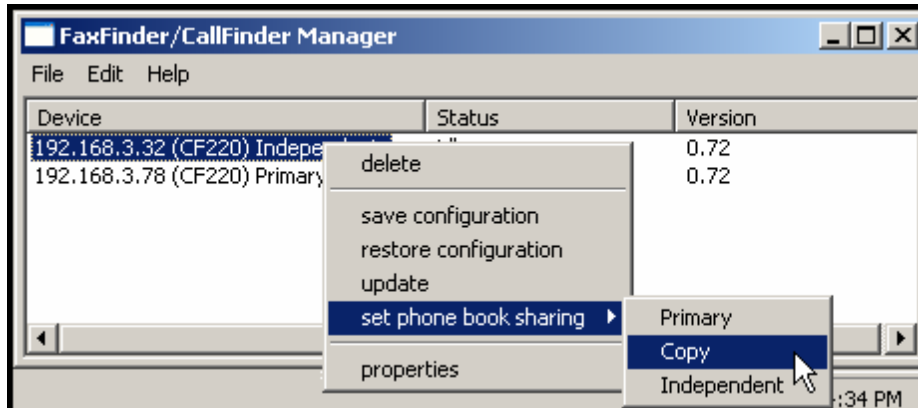

3. *Invoking synchronization.* In the main **FFCF Manager** screen, open the **Edit** menu and select **Synchronize Phonebooks**. The **Synchronize Phone Books** screen will appear along with a series of transient screens (denoting tftp data transfers) and confirmation screens (where you click **OK** to proceed).

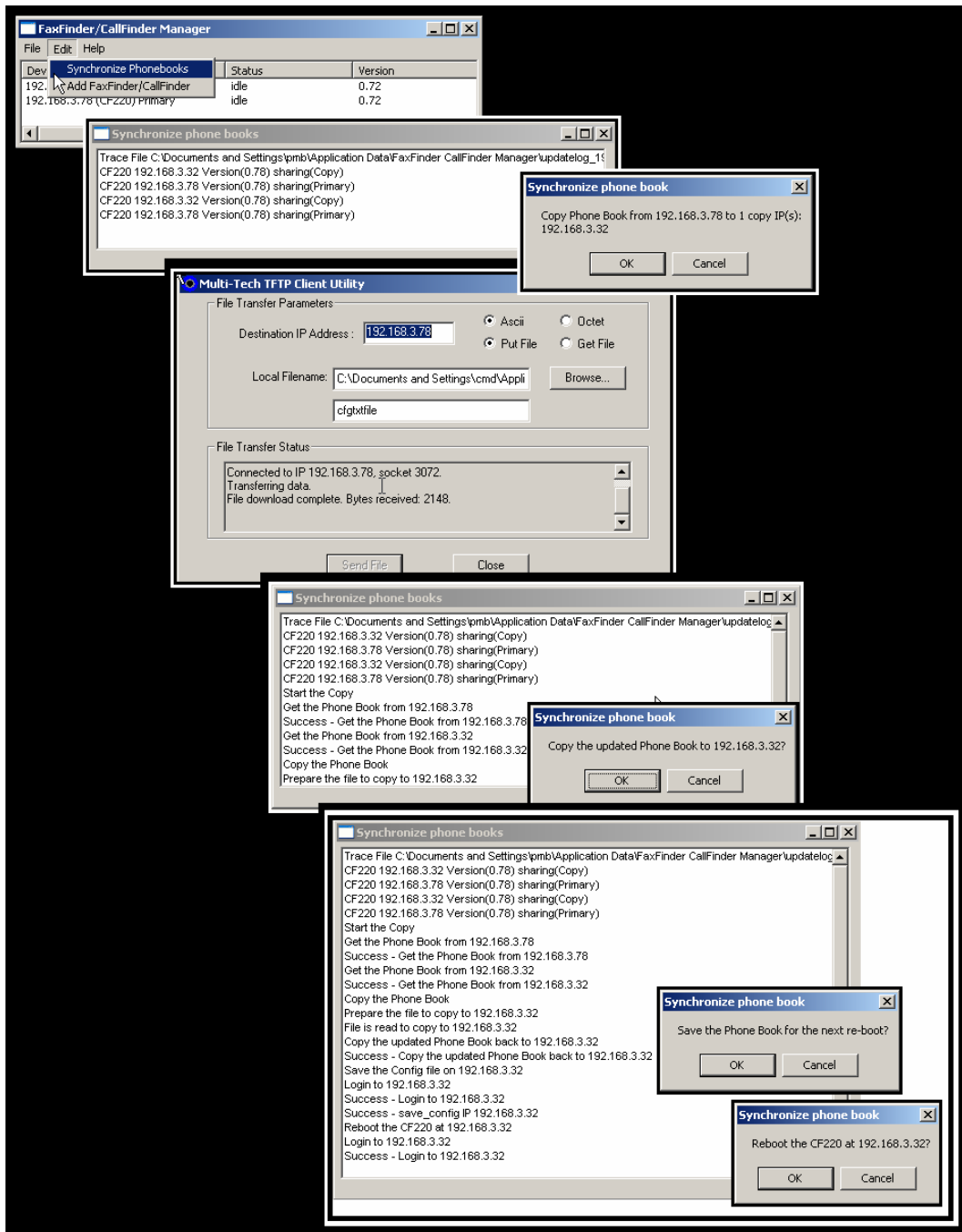

After the master phonebook has been transferred to the first **Copy** CallFinder unit and that unit has been rebooted, the **FFCF Manager** will automatically begin synchronizing the additional **Copy** CallFinder unit in the system (if any) until all have been synchronized.

To see the newly synchronized phonebook list in each **Copy** CallFinder unit, you must update the Phone Book screen by clicking on the **Phone Book** button (to the right of **Administration**) in the list at the top of the screen.

Adding CallFinders

Any CallFinder unit to be added to the system and come under the management of the FFCF Manager software must be connected to the same IP network as the computer running the FFCF Manager software.

To add a CallFinder to the system, start at the main FFCF Manager screen. Open the **Edit** menu and select **Add FaxFinder/CallFinder**. When the **Add FaxFinder/CallFinder Address** screen appears, enter the IP address, Username, and Password for the unit you are adding to the system. Then click **OK**.

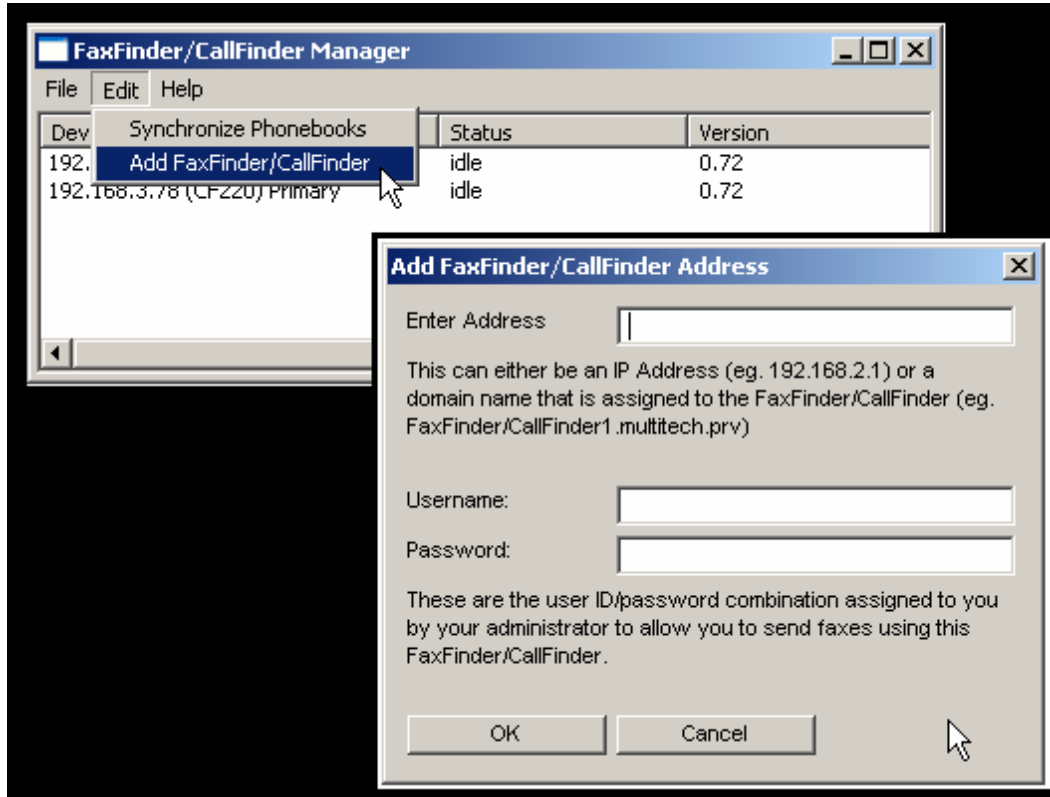

Right-Click Menu for Selected CallFinder Device

Right-Click Menu Command	Description
Delete	Dis-associates the selected CallFinder unit from the system of CallFinders listed in the FFCF software Device column.
Save Configuration	Saves the settings of the CallFinder's built-in software, including the phonebook, on the PC on which the FFCF Manager software is running.
Restore Configuration	For the selected CallFinder unit, this command re-imports a previously saved version of the unit's software settings (including phonebook) back into that CallFinder unit.
Update [firmware]	Lets you install the latest firmware for the CallFinder server and/or its 'channels' (DID modems).
Set Phone Book Sharing	Lets you designate the selected CallFinder unit as either "Independent," "Primary," or "Copy." The Primary phone book is the source list that can be transferred to CallFinders in the system that have been designated as Copy. Independent CallFinder units do not share phone book information. Default= Independent
Properties	Displays IP address, user name, and password of selected CallFinder unit. (For the password, only the number of characters is shown.)

Deleting a CallFinder

Invoking the **Delete** command removes the selected CallFinder unit from the system. Once deleted, the CallFinder unit will no longer be under the management of the **FFCF Manager** software. Click **Yes** at the 'confirmation' screen to complete the deletion command.

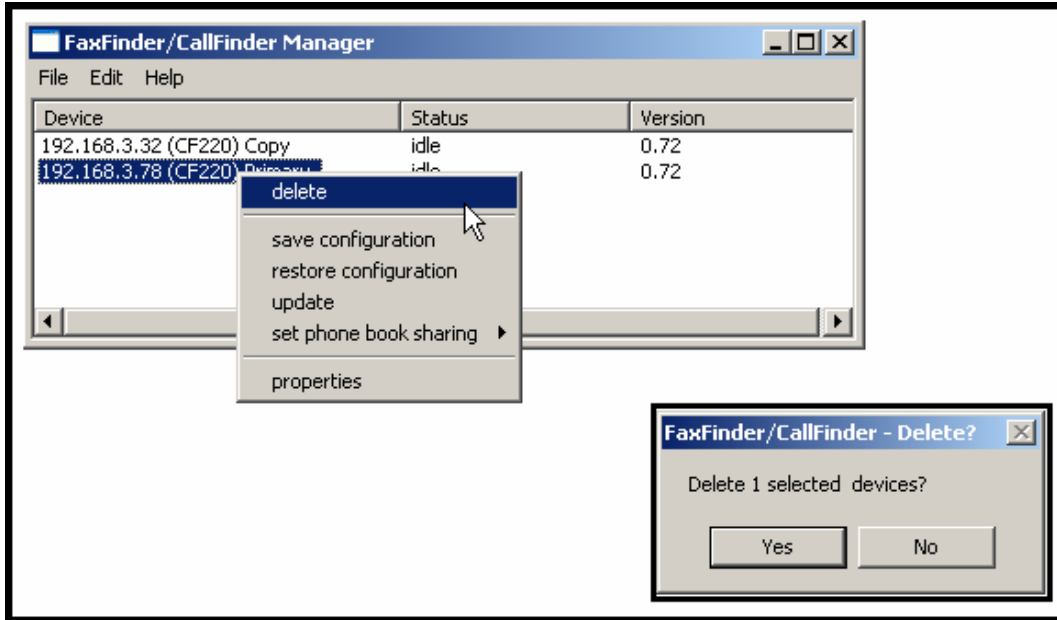

Saving a Configuration

The CallFinder saves all of its settings (IP address, password, DID channel modem parameters, phone book, etc.) internally. This group of settings is its configuration. This same group of settings can be saved on the computer running the FFCF Manager software. Once saved, the configuration can be retrieved from the computer and re-installed onto the CallFinder unit using the **Restore Configuration** command.

To save the configuration for a particular CallFinder unit, select the unit in the main FFCF Manager screen, right-click on it, and select **Save Configuration**. Choose the location at which the configuration file will be stored and click **OK**. Then, at the 'confirmation' screen, click **OK** again.

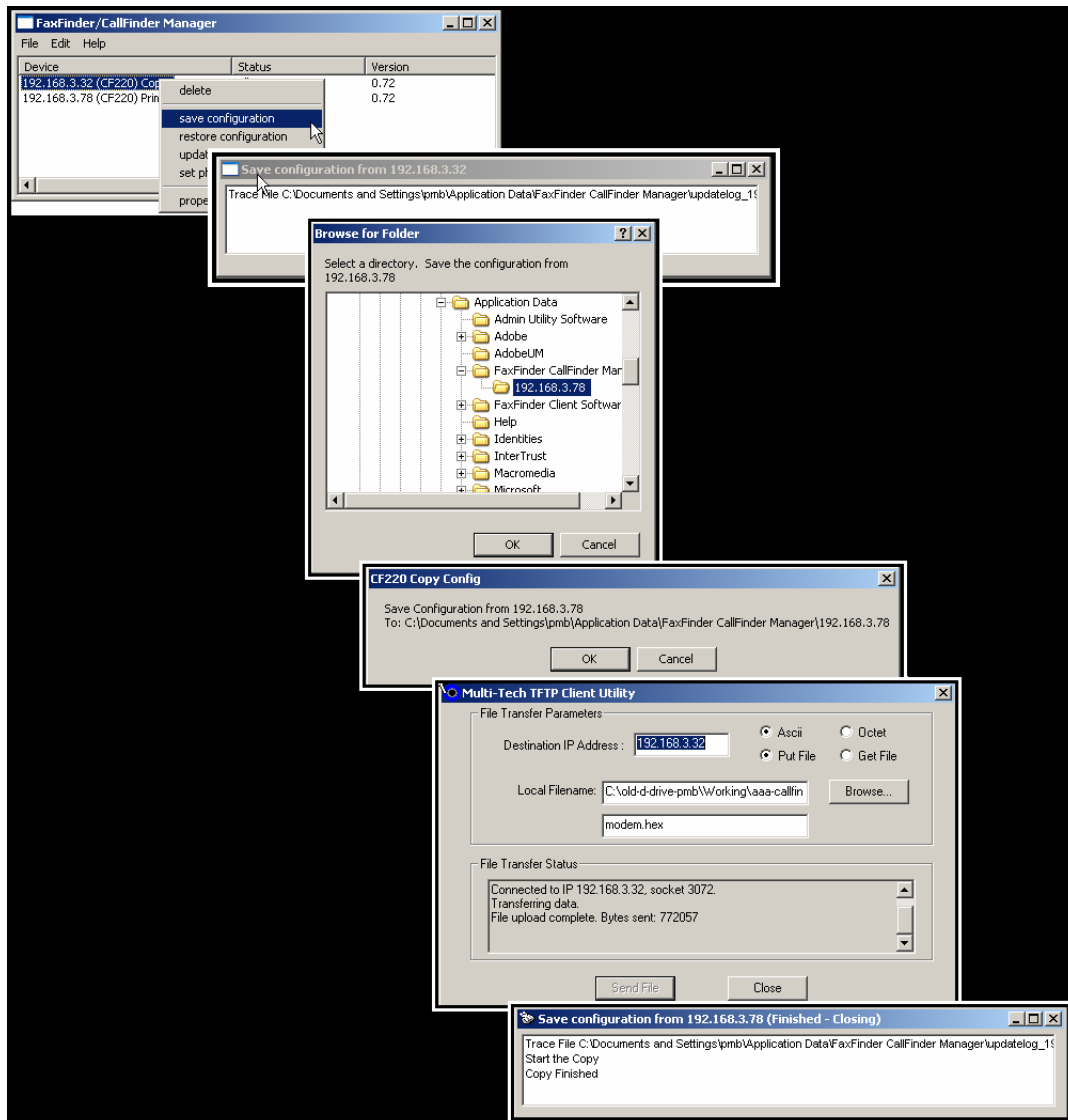

Restoring a Configuration

To re-install on the CallFinder unit a group of settings (configuration) previously saved on the computer running the **FFCF Manager** software, use the **Restore Configuration** command. FFCF Manager will browse, by default, to an automatically determined directory that contains a saved configuration.

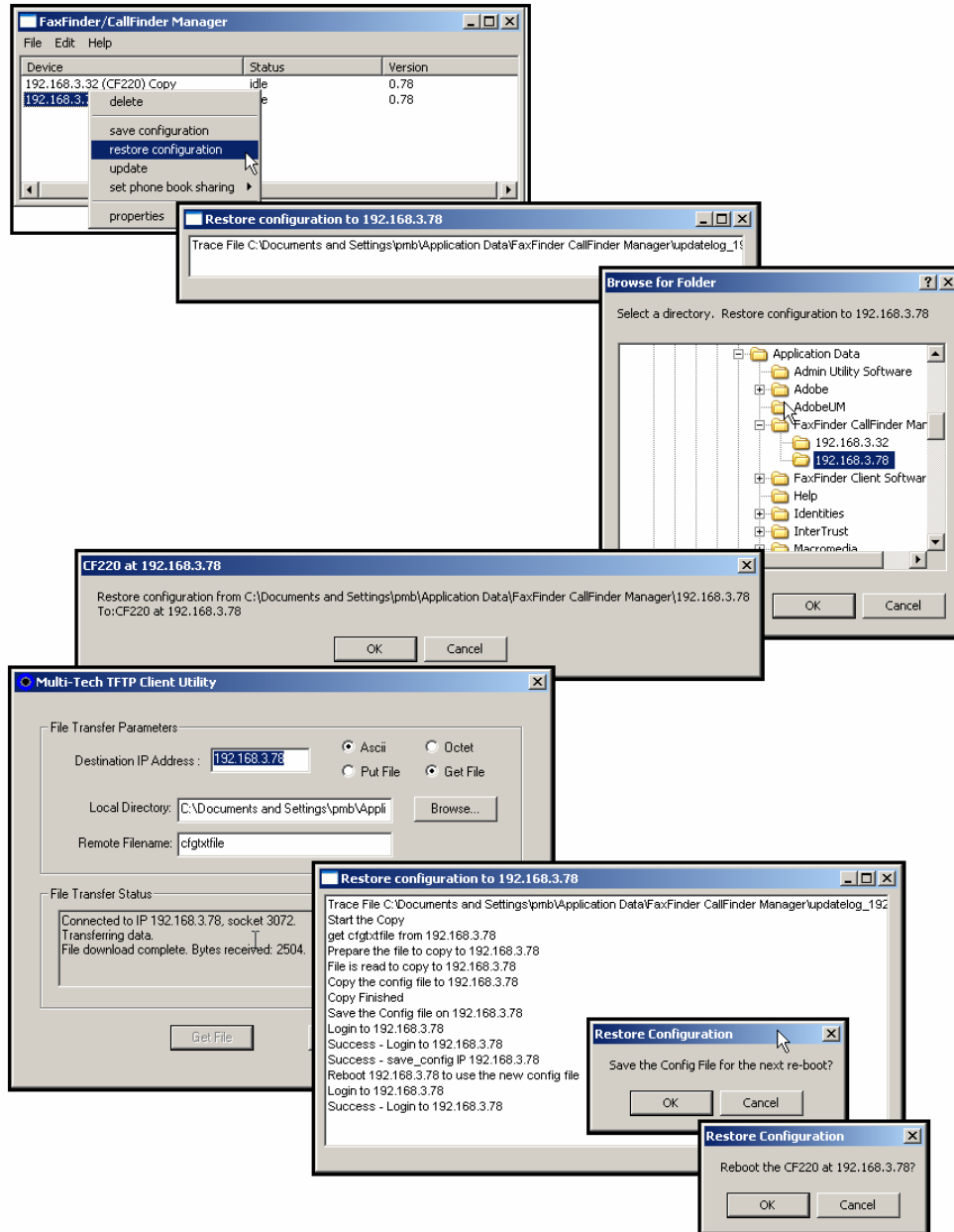

Updating Firmware

When **Update** command is invoked, the **Update CallFinder N.N.N.N** screen appears. From this screen you specify which device (server or DID channel modem) to update with which firmware file. From this screen, you can also identify the firmware versions currently installed and initiate the update process.

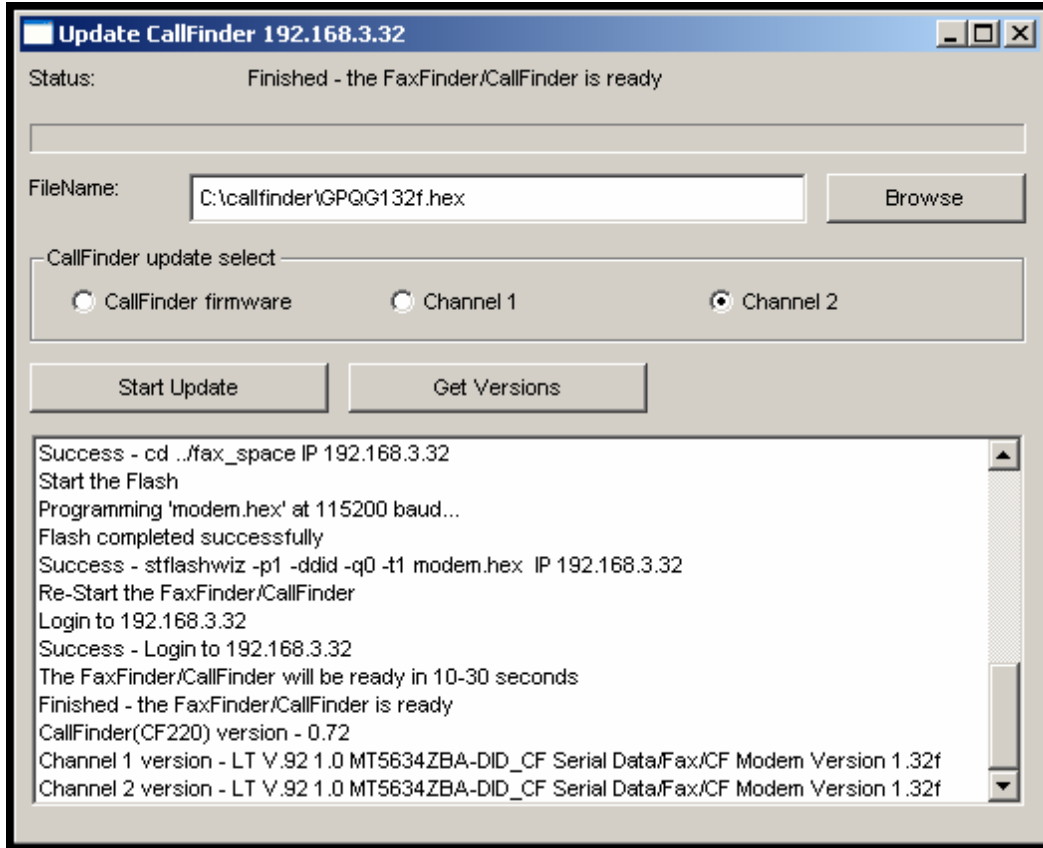

Update CallFinder N.N.N.N Field	Description
Status	Identifies the current condition of the CallFinder or the current process underway.
Progress Bar	Shows how far current process is from completion.
File Name	Lists name of firmware file to be used to update CallFinder server or DID channel modem.
Browse button	Use to locate firmware file to be installed.
CallFinder update select	Identifies which device (server or DID channel modem) to be updated.
Start Update button	Initiates flashing of firmware.
Get Versions button	Press for listing of versions of firmware for CallFinder server and DID channel modems.
main pane of window	Presents CallFinder status and details of updating processes as they occur.

Setting Phone Book Sharing

The phonebook of a **Primary** CallFinder unit is a source or central phonebook. Phone numbers should be entered into this phonebook. The central phonebook list is downloaded (by use of **Synchronize Phonebooks** command) from the Primary CallFinder unit into the phonebook of each **Copy** CallFinder unit. If phone numbers are added to the phonebook of a **Copy** CallFinder phonebook, they will be overwritten and lost at the next **Synchronize Phonebooks** command.

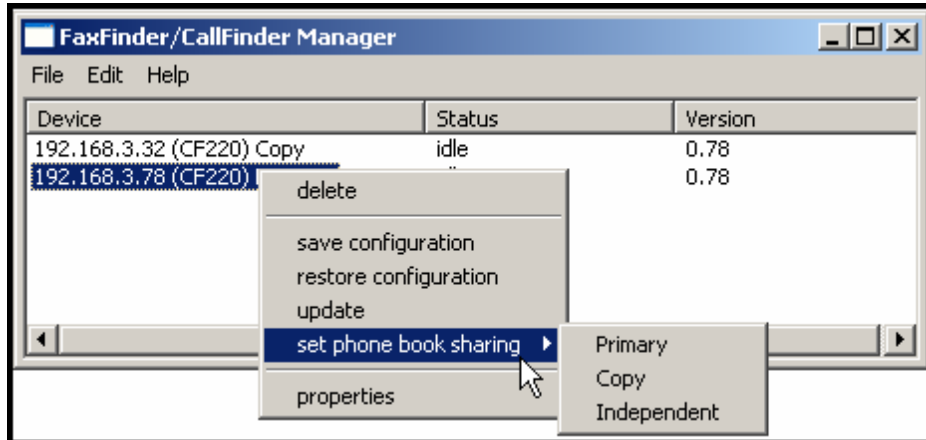

Phonebooks of **Independent** CallFinder units do not participate in phonebook sharing.

Viewing Properties

The **Properties** command brings up the FaxFinder/CallFinder – N.N.N.N screen on which you can view the IP Address and Username of the CallFinder and determine the number of characters in its Password.

Firmware Updating Process - Detailed

Over time, new versions of CallFinder firmware will be issued. When these newer versions become available, you will want to secure the firmware files (typically by downloading them from the MultiTech web site) and install them in the CallFinder.

There are three parts to a full firmware update:

- (a) updating DID Channel1/Modem firmware (with file name of the form **gpqg<x><y>.hex**; where **x** is a number and **y** is a letter),
- (b) updating DID Channel2/Modem firmware (same file name as above), and
- (c) updating CallFinder server firmware (with file name of the form **CF220-<x>-<yz>.bin**).

NOTE: You must have the update files on your computer **before** beginning this procedure. The latest version of these files will be available on the MultiTech web site. Put them in a directory on a computer connected to the network on which the CallFinder unit is running.

NOTE: Updating the CallFinder unit will take it out of operation for a few minutes (allow 10 minutes for each update if you already have the new firmware in a directory on the host computer). Do the update at a time that is not critical to your organization's usage of DID service.

To update firmware, follow the steps shown below.

CallFinder Channel-Modem Firmware Update

1. Bring up the **FaxFinder/CallFinder Manager** software main screen. In the **Device** column, identify the CallFinder unit on which the update is to be done. Be sure that the Status of that CallFinder unit is **idle** before continuing. (You cannot update the CallFinder while it is handling a call.) Select that CallFinder unit and right-click on it. In the menu that appears, select **Update**.

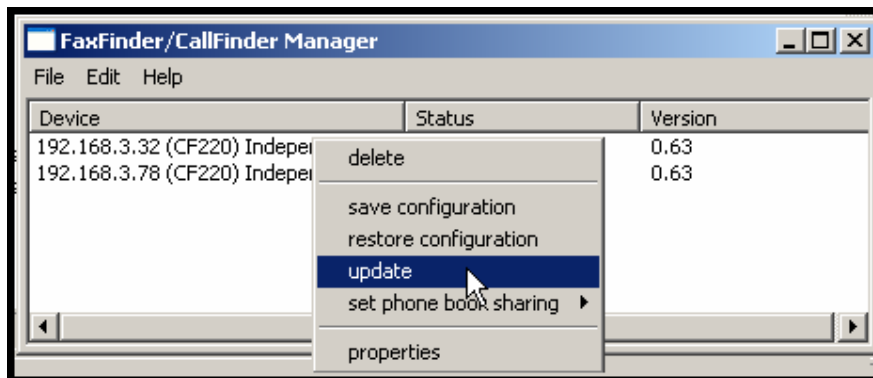

2. The **Update CallFinder N.N.N.N** screen will appear. The current firmware versions for the CallFinder's DID modems, Channel 1 and Channel 2, will be listed in the main window.

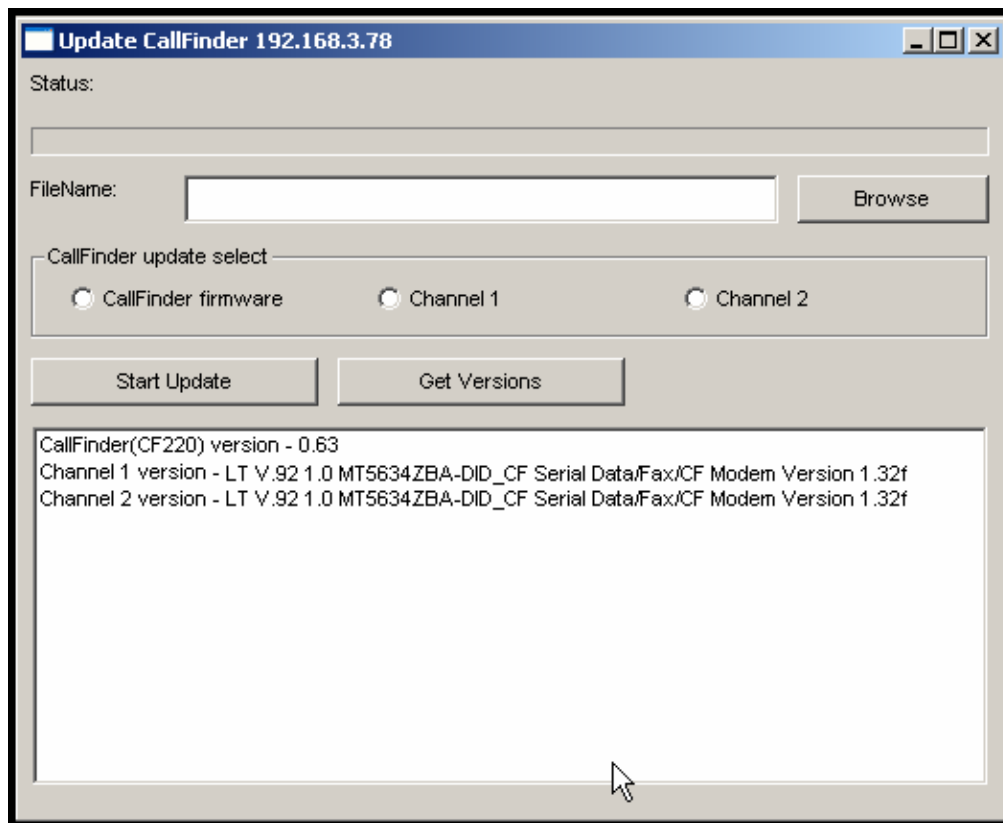

In the bottom (and largest) pane of the **Update CallFinder n.n.n.n** window, read the list and write down the version of firmware currently in use for the two DID-channel modems. Compare these versions with the update file that you plan to use. *Make sure that the file to be installed really does supersede the one currently installed.*

In the **CallFinder Update Select** field, select the DID-channel modem that you want to update (Channel 1 or Channel 2).

3. Browse to the location of the most recent firmware file.

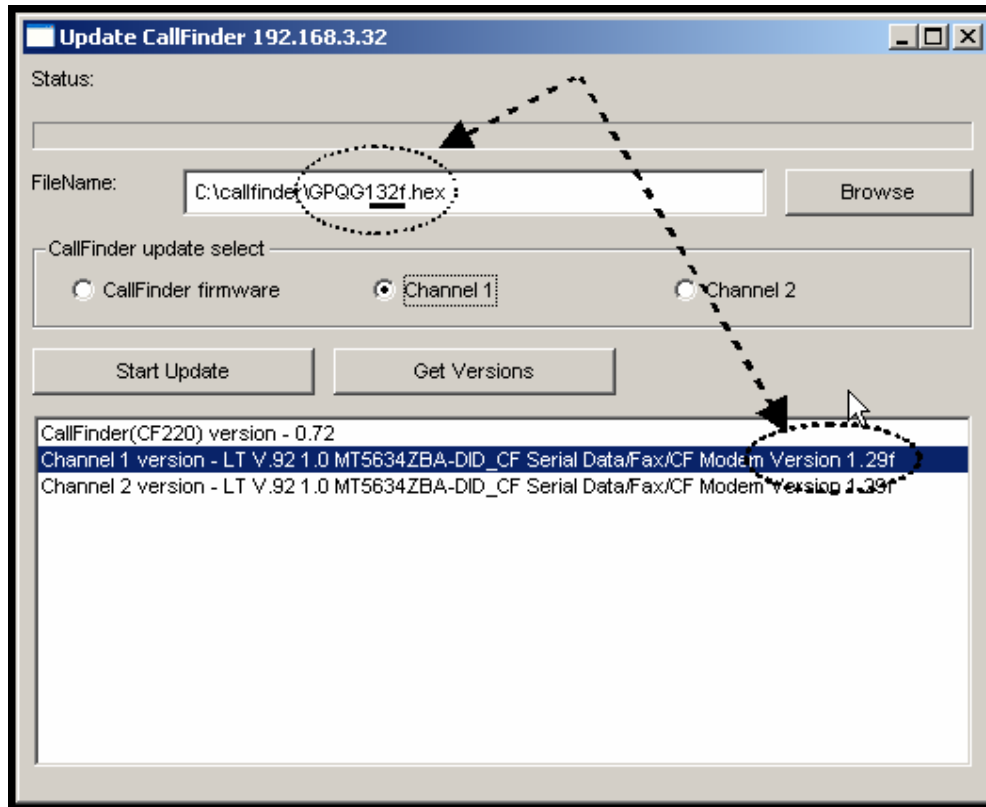

4. Click **Start Update**.
5. The **CallFinder – Confirm Update** screen will appear. Click **OK**.

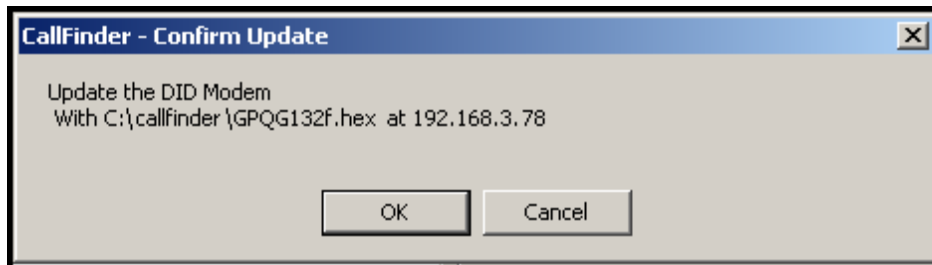

6. The updating process will take as long as a minute. During this time, several messages will appear in the **Update CallFinder N.N.N.N** window. A transient **TFTP** screen may appear briefly. If the updating process has been successful, the final message line will say “Finished – The FaxFinder/CallFinder is ready.”

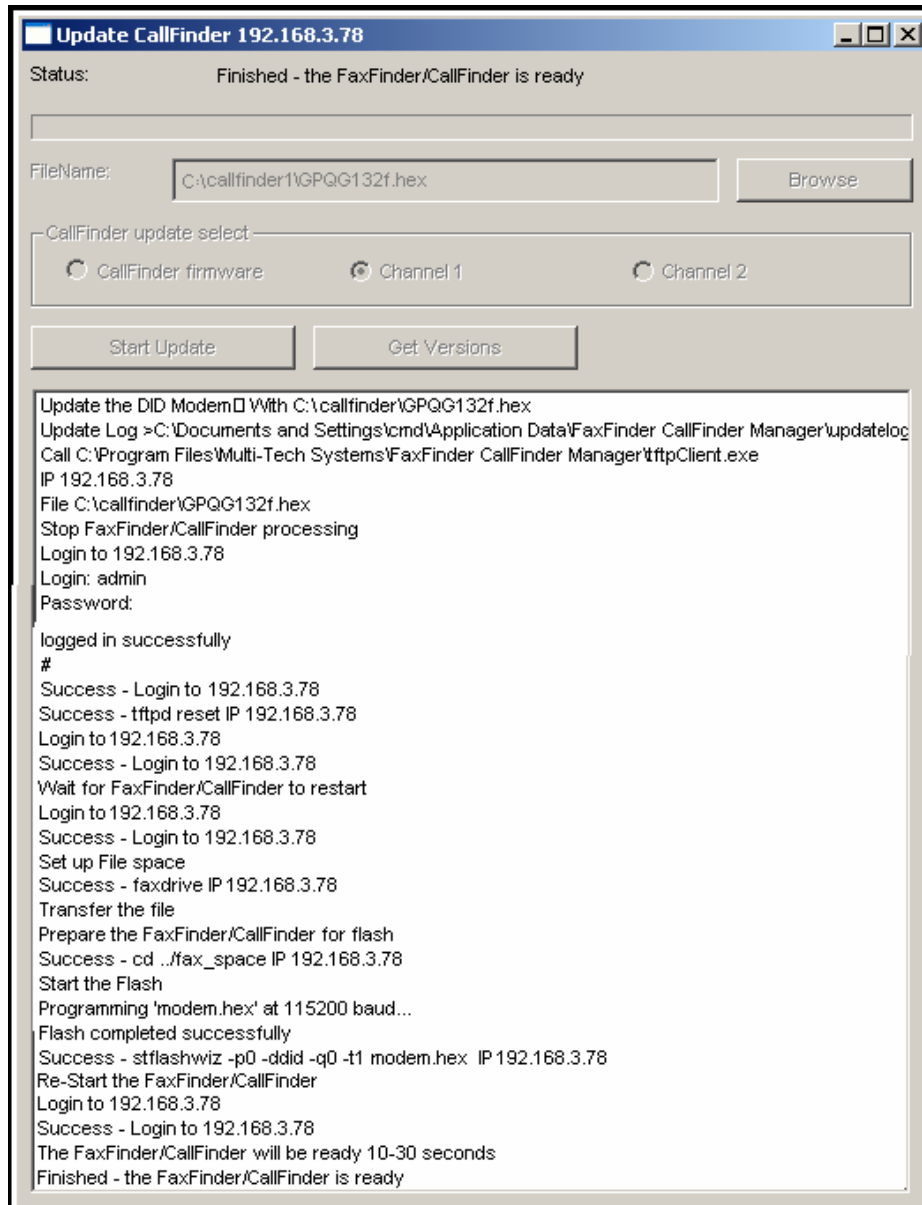

7. Repeat steps 1-6 for the second channel of this CallFinder unit. For consistency of operation, update both channels of all CallFinder units in the system.

8. The updating process is now complete. Click the “X” in the upper-right corner to return to the main **FFCF Manager** screen.

CallFinder Server Firmware Update

1. Bring up the **FaxFinder/CallFinder Manager** software main screen. In the **Device** column, identify the CallFinder unit on which the update is to be done. Be sure that the Status of that CallFinder unit is **idle** before continuing. (You cannot update the CallFinder while it is handling a call.) Select that CallFinder unit and right-click on it. In the menu that appears, select **Update**.

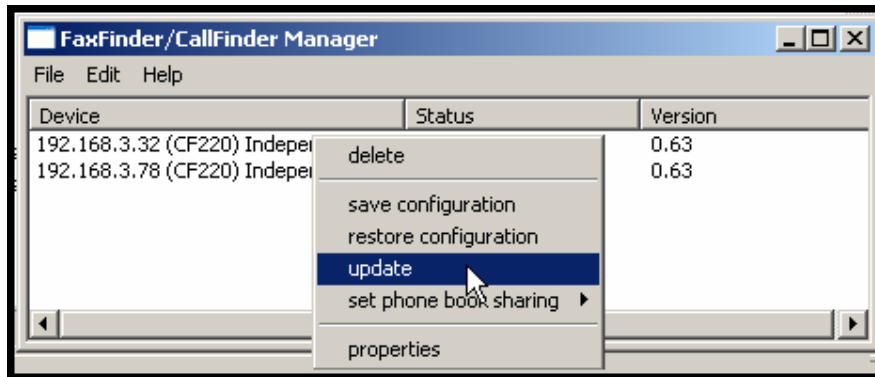

2. The **Update CallFinder N.N.N.N** screen will appear. The current firmware versions for the CallFinder server, for Channel 1, and for Channel 2 will be listed in the main window.

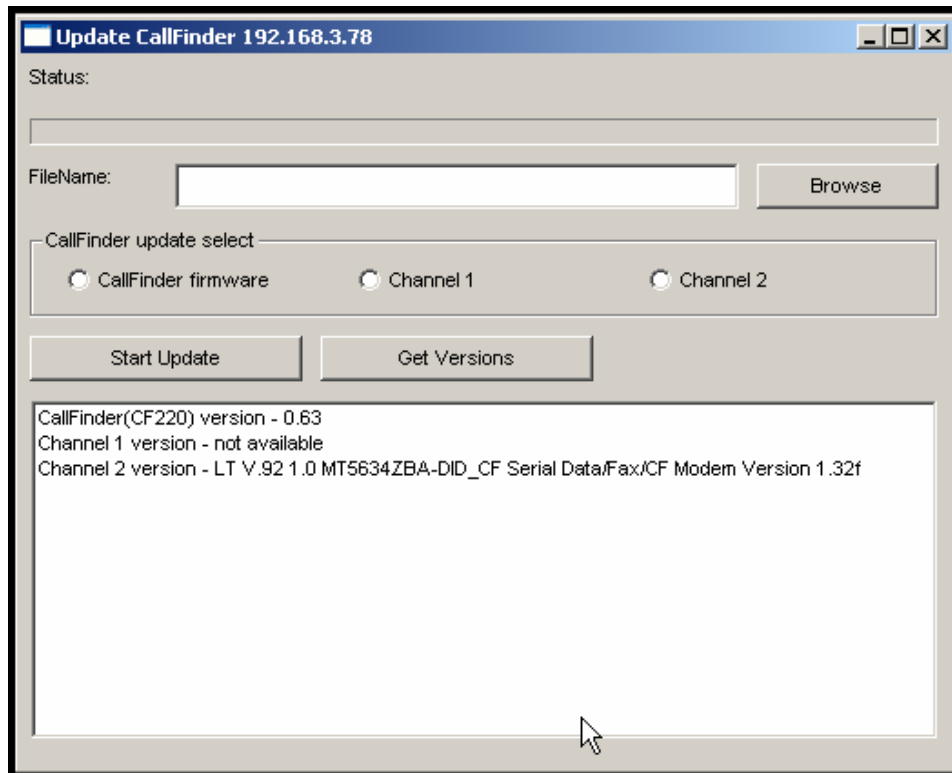

In the bottom (and largest) pane of the **Update CallFinder N.N.N.N** window, read the list and write down the version of firmware currently in use for the CallFinder server and its two DID-channel modems. Compare these versions with the update files that you plan to use. Make sure that the files to be installed really do supersede the ones currently installed on the CallFinder.

In the **CallFinder Update Select** field, select “CallFinder firmware.”

3. Browse to the location of the most recent firmware file.

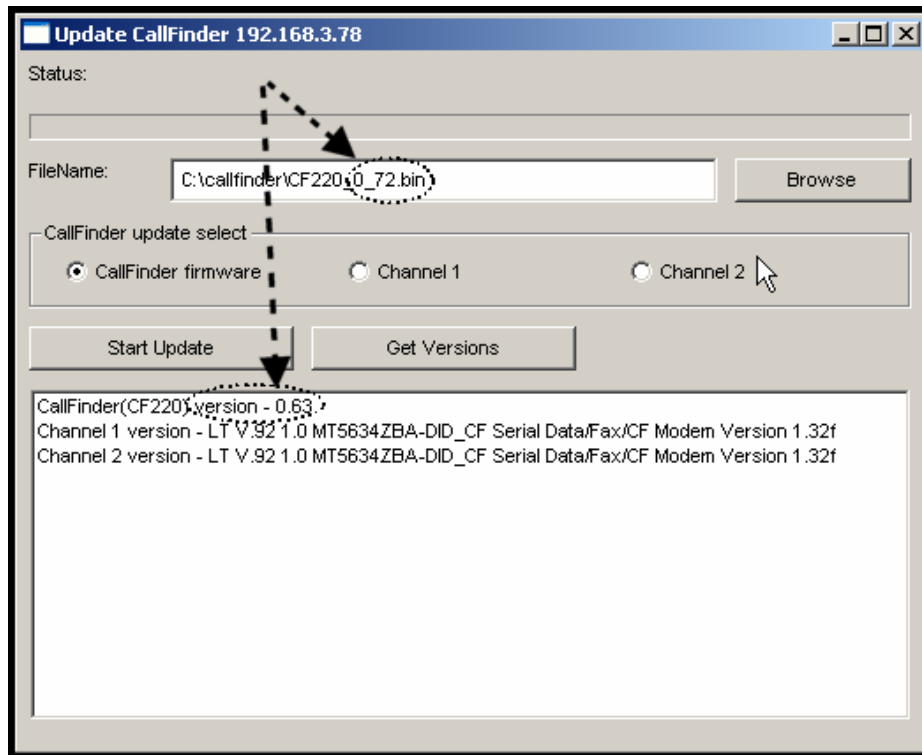

4. Click **Start Update**.

5. The **CallFinder – Confirm Update** screen will appear. Click **OK**.

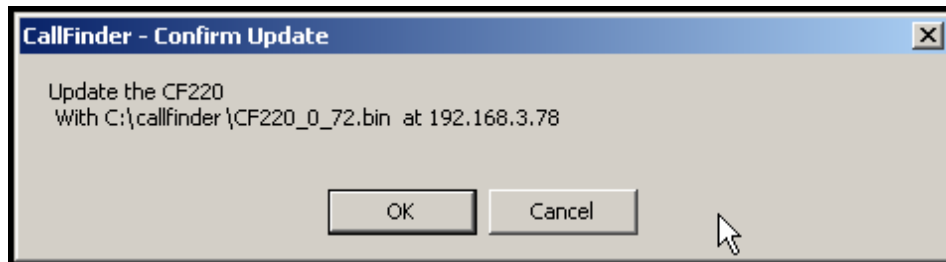

6. The updating process will take as long as a minute. During this time, several messages will appear in the **Update CallFinder N.N.N.N** window. A transient **TFTP** screen may appear briefly. If the updating process has been successful, the final message line will say “Finished – The FaxFinder/CallFinder is ready.”

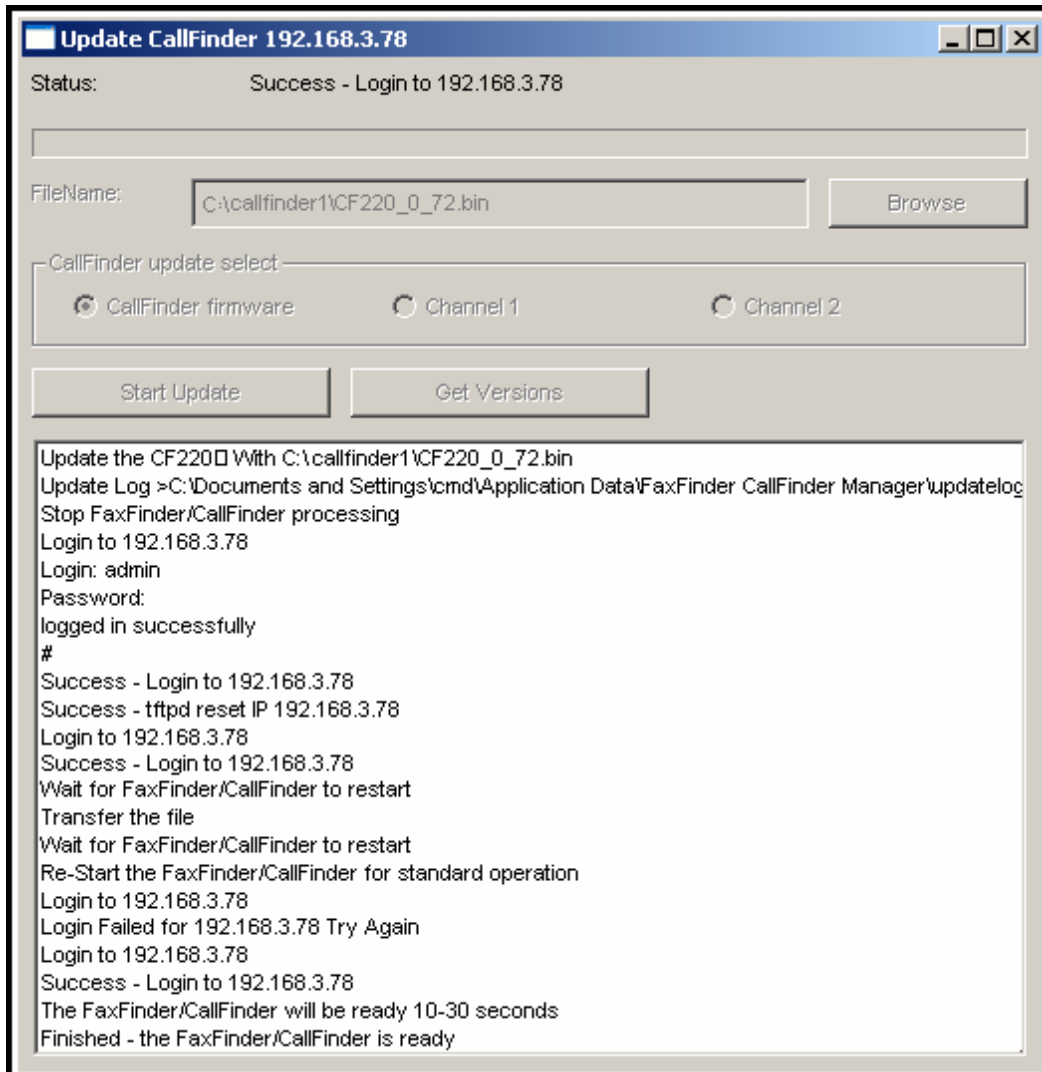

7. Close the **Update CallFinder N.N.N.N** window. In the main **FFCF Manager** window, the updated version will be listed.

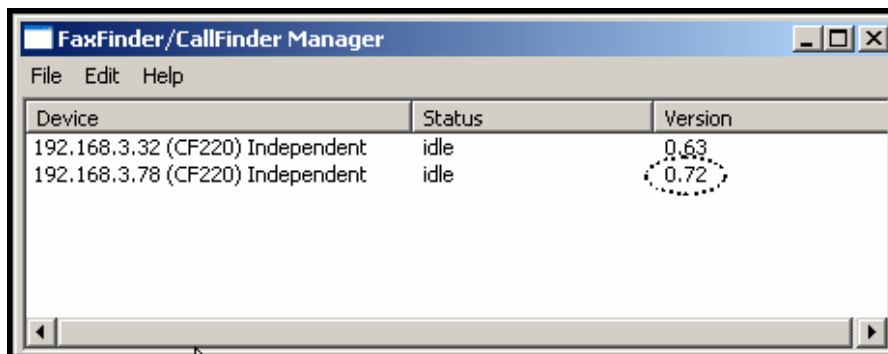

8. Repeat steps 1-7 for each CallFinder unit in the system.

NOTE: For proper operation of the CallFinder system, including the sharing of Phone Book data, the server firmware version for all CallFinder units must be the same.

9. The updating process is now complete. Click the “X” in the upper-right corner to return to the main **FFCF Manager** screen.

Chapter 8: Troubleshooting

1. What if I can't see the web page for my CallFinder ?

REMEDY: Is the status LED on the CallFinder unit blinking? If not, then the unit is either malfunctioning or not turned on. If the Status LED is blinking, then verify that the Admin PC is actually on the same subnet as the CallFinder and that the CallFinder can be “pinged.”

Launch a Command Prompt.

(In WinNT, go to **Start | Programs | Command Prompt.**

In WinXP, go to **Start | All Programs | Accessories | Command Prompt.**

In Win2000, go to **Start | Programs | Accessories | Command Prompt.**)

Type **ipconfig** to verify that the Admin PC’s IP address is in the same network as the CallFinder’s IP address.

Then type **ping 192.168.2.1** and press **Return**.

If the CallFinder unit does reply to the ping and you are still unable to view the CallFinder web page, then call Multi-Tech Tech Support for more assistance (1-800-972-2439).

2. What if I don't get an email when I set the mail server address ?

This pertains to the procedure “Setting Up the Mail Server.”

The email may have failed due to one of three causes:

- (A) the name server is unresolvable (in this case, “Bad Mail Server Address” will appear in the **Email Status** field of the **Current Status** screen),
- (B) the mail server cannot be contacted; or
- (C) the client PC running the mail software cannot connect to the mail server.

CAUSE A: During transmission, the name server’s address could not be resolved (that is, the CallFinder unit could not contact your name server).

RESPONSE A: Contact the CallFinder unit using telnet and try to ping the name server.

```
telnet 192.168.x.x
```

```
user: admin
```

```
password: admin
```

```
# ping 192.168.y.y (where this is the address of the name server)
```

If the name server ping fails, you must determine why it failed.

The name server may not be contact-able because it is on a different subnet. The name server ping could also fail because the default gateway has been set incorrectly.

If the name server ping succeeds, then try to ping the mail server using its domain name.

```
# ping mail.ourcompany.com
```

If pinging the mail server by its domain name fails, then try pinging it by using its IP address (if this can be determined). If you succeed in pinging the mail server by its IP address but yet it cannot be pinged via its domain name, then the name server is not functioning correctly (or the device at the name server’s IP address is not a name server).

No email message after mail server setup (cont'd)

If the mail server can be pinged neither by its domain name nor by its IP address, then consider item B below.

CAUSE B: The mail server is not running or cannot be contacted from the CallFinder unit.

RESPONSE B: Verify that the mail server is running by sending an email to yourself using your email software.

If you cannot send an email to yourself using your email software, then the mail server is not running and you should find out why.

If you can send an email to yourself using the email software, then there is a problem between your mail server and the CallFinder unit. Call Multi-Tech Tech Support (1-800-972-2439).

Username/Password Issues. Some mail servers require that the CallFinder use its Username and Password to log into the mail server. Others do not. This Username and Password are specified in the **Administration: SMTP Configuration** screen. If the mail server requires the CallFinder to have a Username and Password and none is provided, access will be denied. Conversely, if the mail server does not require a Username and Password and these have been specified anyway, again access will be denied. If call logs are not reaching the administrator, it may be because of such Username/Password issues.

CAUSE C: The client PC running the mail software cannot connect to the mail server.

RESPONSE C: If you, as a client, cannot send yourself an email, then contact your administrator; there may be a problem with your mail server.

3. What if the CallFinder channel doesn't answer a call on the DID line?

REMEDY. Use this procedure if Channel Configuration cannot be confirmed (that is, if during a test call to one of the system's DID phone numbers, you fail to see the "Waiting for Connect" State in the **Current Status: Channel-1/Channel-2** screen and if you fail to hear voice-- both the state and the sound must be observable).

- A. Situate yourself in a place where you can see the CallFinder unit and, simultaneously, use a phone on a regular POTS line.
- B. From that ordinary POTS phone, dial one of the DID phone numbers that is active in the system.
- C. As the call is completed, watch the LEDs on the front panel of the CallFinder unit.

If the DID LED remains off, then there is probably a telephony problem. That is, the DID phone line has not been activated or configured properly. Call the telephone company.

If the DID LED comes ON, then there is something wrong with the CallFinder software. Call MultiTech Tech Support (1-800-972-2439).

- D. **Polarity Check.** Incorrect DID polarity could also prevent calls from being answered.

Signs of incorrect polarity:

- (1) outside party originating call to DID number gets immediate busy signal after dialing;
- (2) line suddenly disconnects just when call should go through.

- E. **Call Logs.** If calls have failed, you can check the CallFinder's call logs to see the actual DID number that the CallFinder received. Sometimes corrupted DID numbers are presented to the CallFinder. In any event, the call logs can help to track down the error involved.

4. What if the CallFinder presents the wrong time of day?

Or, what if the CallFinder marks calls with the wrong time of day? What if the message "SNTP Error ..." appears in the *Time Server Status* field of the **Current Status** screen?

REMEDY: The CallFinder may have lost contact with the time server. By default, the CallFinder obtains its time from an Internet source. If the CallFinder is isolated from the Internet, then you must provide a different time source within the private ethernet network.

5. What if an immediate busy signal is received when dialing in on the DID line?

REMEDY

- A. Check for "Busied Out" condition of channel on **Current Status** screen. If the channel is busied out, click "Initialize Channel."
- B. Reverse DID line polarity in **Channel Configuration** screen.

6. What if the line suddenly disconnects just when a call is about to be connected?

REMEDY: Reverse DID line polarity in **Channel Configuration** screen.

Chapter 9 – Regulatory Information

47 CFR Part 68 Telecom

1. This equipment complies with Part 68 of the 47 CFR rules and the requirements adopted by the ACTA. Located on this equipment is a label that contains, among other information, the registration number and ringer equivalence number (REN) for this equipment or a product identifier in the format:

For current products is **US:AAAEQ##Txxxx**.

For legacy products is **AU7USA-xxxxx-xx-x**.

If requested, this number must be provided to the telephone company.

2. A plug and jack used to connect this equipment to the premises wiring and telephone network must comply with the applicable 47 CFR Part 68 rules and requirements adopted by the ACTA. It's designed to be connected to a compatible modular jack that is also compliant.
3. The ringer equivalence number (REN) is used to determine the number of devices that may be connected to a telephone line. Excessive RENs on a telephone line may result in the devices not ringing in response to an incoming call. In most but not all areas, the sum of RENs should not exceed five (5.0). To be certain of the number of devices that may be connected to a line, as determined by the total RENs, contact the local telephone company. For products approved after July 23, 2001, the REN for this product is part of the product identifier that has the format US:AAAEQ##Txxxx. The digits represented by ## are the REN without a decimal point (e.g., 03 is a REN of 0.3). For earlier products, the REN is separately shown on the label.
4. If this equipment causes harm to the telephone network, the telephone company will notify you in advance that temporary discontinuance of service may be required. But if advance notice isn't practical, the telephone company will notify the customer as soon as possible. Also, you will be advised of your right to file a complaint with the FCC if you believe it is necessary.
5. The telephone company may make changes in its facilities, equipment, operations or procedures that could affect the operation of the equipment. If this happens, the telephone company will provide advance notice in order for you to make necessary modifications to maintain uninterrupted service.
6. If trouble is experienced with this equipment, please contact Multi-Tech Systems, Inc. at the address shown below for details of how to have the repairs made. If the equipment is causing harm to the telephone network, the telephone company may request that you disconnect the equipment until the problem is resolved.
7. Connection to party line service is subject to state tariffs. Contact the state public utility commission, public service commission or corporation commission for information.
8. No repairs are to be made by you. Repairs are to be made only by Multi-Tech Systems or its licensees. Unauthorized repairs void registration and warranty.
9. If your home has specially wired alarm equipment connected to the telephone line, ensure the installation of this equipment does not disable your alarm equipment.

If you have questions about what will disable alarm equipment, consult your telephone company or a qualified installer.
10. Connection to party line service is subject to state tariffs. Contact the state public utility commission, public service commission or corporation commission for information.
11. This equipment is hearing aid compatible.

12. Manufacturing Information:

Manufacturer: Multi-Tech Systems, Inc.
 Trade Name: CallFinder
 Model Number: CF220
 Registration No: US: AU7OTNANCF220
 Ringer Equivalence: 0.4B
 Modular Jack (USOC): RJ11C or RJ11W (single line),
 RJ12
 Service Center in USA: Multi-Tech Systems, Inc.
 2205 Woodale Drive
 Mounds View, MN 55112 U.S.A.
 (763) 785-3500
 (763) 785-9874 Fax

47 CFR Part 15 Regulation

This equipment has been tested and found to comply with the limits for a **Class B** digital device, pursuant to 47 CFR Part 15 regulations. The stated limits in this regulation are designed to provide reasonable protection against harmful interference in a residential installation. This equipment generates, uses, and can radiate radio frequency energy, and if not installed and used in accordance with the instructions, may cause harmful interference to radio communications. However, there is no guarantee that interference will not occur in a particular installation. If this equipment does cause harmful interference to radio or television reception, which can be determined by turning the equipment off and on, the user is encouraged to try to correct the interference by one or more of the following measures:

Reorient or relocate the receiving antenna.

Increase the separation between the equipment and receiver.

Plug the equipment into an outlet on a circuit different from that to which the receiver is connected.

Consult the dealer or an experienced radio/TV technician for help.

This device complies with Part 15 of the CFR 47 rules. Operation of this device is subject to the following conditions: (1) This device may not cause harmful interference, and (2) this device must accept any interference that may cause undesired operation.

Warning: Changes or modifications to this unit not expressly approved by the party responsible for compliance could void the user's authority to operate the equipment.

Fax Branding Statement

The Telephone Consumer Protection Act of 1991 makes it unlawful for any person to use a computer or other electronic device, including fax machines, to send any message unless such message clearly contains the following information:

- Date and time the message is sent
- Identification of the business or other entity, or other individual sending the message
- Telephone number of the sending machine or such business, other entity, or individual

This information is to appear in a margin at the top or bottom of each transmitted page or on the first page of the transmission. (Adding this information in the margin is referred to as *fax branding*).

Any number of fax software packages can be used with this product. Refer to the fax software manual for setup details. Typically, the fax branding information must be entered via the configuration menu of the software.

Canadian Limitations Notice

Notice: The ringer equivalence number (REN) assigned to each terminal device provides an indication of the maximum number of terminals allowed to be connected to a telephone interface. The termination on an interface may consist of any combination of devices subject only to the requirement that the sum of the ringer equivalence numbers of all the devices does not exceed 5.

Notice: The Industry Canada label identifies certified equipment. This certification means that the equipment meets certain telecommunications network protective, operational, and safety requirements. The Industry Canada label does not guarantee the equipment will operate to the user's satisfaction.

Before installing this equipment, users should ensure that it is permissible to be connected to the facilities of the local telecommunications company. The equipment must also be installed using an acceptable method of connection. The customer should be aware that compliance with the above conditions may not prevent degradation of service in some situations. Repairs to certified equipment should be made by an authorized Canadian maintenance facility designated by the supplier. Any repairs or alterations made by the user to this equipment or equipment malfunctions may give the telecommunications company cause to request the user to disconnect the equipment.

Users should ensure for their own protection that the electrical ground connections of the power utility, telephone lines and internal metallic water pipe system, if present, are connected together. This precaution may be particularly important in rural areas.

Caution: Users should not attempt to make such connections themselves, but should contact the appropriate electric inspection authority, or electrician, as appropriate.

Industry Canada

This Class B digital apparatus meets all requirements of the Canadian Interference-Causing Equipment Regulations.

Cet appareil numérique de la classe B respecte toutes les exigences du Règlement Canadien sur le matériel brouilleur.

Chapter 10: Warranty, Service, & Repair

Multi-Tech Warranty Statement

Multi-Tech Systems, Inc., (hereafter "MTS") warrants that its products will be free from defects in material or workmanship for a period of two, five, or ten years (depending on model) from date of purchase, or if proof of purchase is not provided, two, five, or ten years (depending on model) from date of shipment. **MTS MAKES NO OTHER WARRANTY, EXPRESS OR IMPLIED, AND ALL IMPLIED WARRANTIES OF MERCHANTABILITY AND FITNESS FOR A PARTICULAR PURPOSE ARE HEREBY DISCLAIMED.**

This warranty does not apply to any products which have been damaged by lightning storms, water, or power surges or which have been neglected, altered, abused, used for a purpose other than the one for which they were manufactured, repaired by Customer or any party without MTS's written authorization, or used in any manner inconsistent with MTS's instructions.

MTS's entire obligation under this warranty shall be limited (at MTS's option) to repair or replacement of any products which prove to be defective within the warranty period or, at MTS's option, issuance of a refund of the purchase price. Defective products must be returned by Customer to MTS's factory — transportation prepaid.

MTS WILL NOT BE LIABLE FOR CONSEQUENTIAL DAMAGES, AND UNDER NO CIRCUMSTANCES WILL ITS LIABILITY EXCEED THE PRICE FOR DEFECTIVE PRODUCTS.

Repair Procedures for U.S. and Canadian Customers

In the event that service is required, products may be shipped, freight prepaid, to our Mounds View, Minnesota factory:

Multi-Tech Systems, Inc.
2205 Woodale Drive
Mounds View, MN 55112
Attn: Repairs, Serial # _____

A Returned Materials Authorization (RMA) is not required. Return shipping charges (surface) will be paid by MTS to destinations in U.S. and Canada.

Please include, inside the shipping box, a description of the problem, a return shipping address (must have street address, not P.O. Box), your telephone number, and if the product is out of warranty, a check or purchase order for repair charges.

For out of warranty repair charges, go to www.multitech.com/DOCUMENTS/Company/warranty/

Extended two-year overnight replacement service agreements are available for selected products. Please call MTS at (888) 288-5470, extension 5308 or visit our web site at

www.multitech.com/PARTNERS/Programs/orc/ for details on rates and coverage's.

Please direct your questions regarding technical matters, product configuration, verification that the product is defective, etc., to our Technical Support department at (800) 972-2439 or email support@multitech.com. Please direct your questions regarding repair expediting, receiving, shipping, billing, etc., to our Repair Accounting department at (800) 328-9717 or (763) 717-5631, or email mtsrepair@multitech.com.

Repairs for damages caused by lightning storms, water, power surges, incorrect installation, physical abuse, or user-caused damages are billed on a time-plus-materials basis.

Repair Procedures for International Customers (Outside U.S.A. and Canada)

Your original point of purchase Reseller may offer the quickest and most economical repair option for your Multi-Tech product. You may also contact any Multi-Tech sales office for information about the nearest distributor or other repair service for your Multi-Tech product. The Multi-Tech sales office directory is available at www.multitech.com/PARTNERS/Channels/offices/

In the event that factory service is required, products may be shipped, freight prepaid to our Mounds View, Minnesota factory. Recommended international shipment methods are via Federal Express, UPS or DHL courier services, or by airmail parcel post; shipments made by any other method will be refused. A Returned Materials Authorization (RMA) is required for products shipped from outside the U.S.A. and Canada. Please contact us for return authorization and shipping instructions on any International shipments to the U.S.A. Please include, inside the shipping box, a description of the problem, a return shipping address (must have street address, not P.O. Box), your telephone number, and if the product is out of warranty, a check drawn on a U.S. bank or your company's purchase order for repair charges. Repaired units shall be shipped freight collect, unless other arrangements are made in advance. Please direct your questions regarding technical matters, product configuration, verification that the product is defective, etc., to our Technical Support department nearest you or email support@multitech.com. When calling the U.S., please direct your questions regarding repair expediting, receiving, shipping, billing, etc., to our Repair Accounting department at +(763) 717-5631 in the U.S.A., or email mtsrepair@multitech.com. Repairs for damages caused by lightning storms, water, power surges, incorrect installation, physical abuse, or user-caused damages are billed on a time-plus-materials basis.

Repair Procedures for International Distributors

Distributors should contact Amex, Inc., for information about the repairs for your Multi-Tech product.

Amex, Inc.
2724 Summer Street NE
Minneapolis, MN 55413 U.S.A.
Tel: +(612) 331-3251
Fax: +(612) 331-3180
Email: info@amexinc.com

Please direct your questions regarding technical matters, product configuration, verification that the product is defective, etc., to our International Technical Support department at +(763)717-5863. When calling the U.S., please direct your questions regarding repair expediting, receiving, shipping, billing, etc., to our Repair Accounting department at +(763) 717-5631 in the U.S.A. or email mtsrepair@multitech.com. Repairs for damages caused by lightning storms, water, power surges, incorrect installation, physical abuse, or user-caused damages are billed on a time-plus-materials basis.

Free Manuals Download Website

<http://myh66.com>

<http://usermanuals.us>

<http://www.somanuals.com>

<http://www.4manuals.cc>

<http://www.manual-lib.com>

<http://www.404manual.com>

<http://www.luxmanual.com>

<http://aubethermostatmanual.com>

Golf course search by state

<http://golfingnear.com>

Email search by domain

<http://emailbydomain.com>

Auto manuals search

<http://auto.somanuals.com>

TV manuals search

<http://tv.somanuals.com>