

OPERATION AND PARTS MANUAL



Mikasa **SERIES**
**MODEL MVH406DSZ/
MVH406DSCPAS**
REVERSIBLE PLATE COMPACTOR
(ROBIN D1B40T92040 DIESEL ENGINE)

Revision #7 (02/28/14)

To find the latest revision of this
publication, visit our website at:
www.multiquip.com



THIS MANUAL MUST ACCOMPANY THE EQUIPMENT AT ALL TIMES.



 WARNING 
CALIFORNIA — Proposition 65 Warning
Diesel engine exhaust and some of its constituents are known to the State of California to cause cancer, birth defects and other reproductive harm.

TABLE OF CONTENTS

MVH406DZ/DSCPAS Reversible Plate Compactor

Proposition 65 Warning	2
Table Of Contents	4
Parts Ordering Procedures.....	5
Safety Information	6-10
Specifications	11
Dimensions.....	12
General Nformation	13
Components	14
Basic Engine.....	15
Inspection	16-17
Operation.....	18-22
Maintenance	23-28
Troubleshooting (Compactor)	29
Troubleshooting (Engine).....	30-31
Explanation of Code in Remarks Column.....	32
Suggested Spare Parts	33

Componet Drawings

Nameplates And Decals	34-35
Vibrating Plate Assembly.....	36-37
Base And Engine Assembly	38-39
Vibrator Assembly	40-41
Control Handle Assembly	42-45
Hand Pump Assembly	46-47
Battery Assembly.....	48-49
Compaction Analyzing System Assembly	50-51
Electric Device Assembly	52-53

Robin D1B40T92040 Diesel Engine

Spare Parts Kit Assembly	54-55
Accessories Assembly.....	56-57
Crankcase Assembly	58-59
Crankshaft Assembly.....	60-61
Camshaft Assembly.....	62-63
Piston Assembly	64-65
Cylinder Head Assembly	66-67
Oil Pump And Gov Assembly	68-69
Timing Assembly	70-73
Blower, Flywheel And Alternator Assembly	74-75
Injection Equipment Assembly	76-79
Recoil Starter Assembly	80-81
Air Ducting (A) Assembly	82-83
Air Ducting (B) Assembly	84-85
Crankcase Breathing System Assembly	86-87
Fuel Tank Assembly	88-91
Air Filter Assembly	92-93
Exhaust Slicencer Assembly	94-95
Starter Regulator Assembly	96-97
Electric Equipment Wiring Assembly	98-99
Speed Control Assembly.....	100-101

Terms And Conditions Of Sale — Parts	102
--	-----

NOTICE

Specifications and part numbers are subject to change without notice.

PARTS ORDERING PROCEDURES

Ordering parts has never been easier! Choose from three easy options:

Effective:
January 1st, 2006

www.multiquip.com



Order via Internet (Dealers Only):

Order parts on-line using Multiquip's SmartEquip website!

- View Parts Diagrams
- Order Parts
- Print Specification Information



If you have an MQ Account, to obtain a Username and Password, E-mail us at: parts@multiquip.com.

To obtain an MQ Account, contact your District Sales Manager for more information.

Goto www.multiquip.com and click on

Order Parts to log in and save!

Use the **internet** and qualify for a **5% Discount** on *Standard orders* for all orders which include complete part numbers.*

Note: Discounts Are Subject To Change

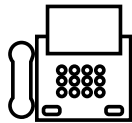

Order via Fax (Dealers Only):

All customers are welcome to order parts via Fax.

Domestic (US) Customers dial:
1-800-6-PARTS-7 (800-672-7877)

Fax your order in and qualify for a **2% Discount** on *Standard orders* for all orders which include complete part numbers.*

Note: Discounts Are Subject To Change



Order via Phone: Domestic (US) Dealers Call:
1-800-427-1244

Non-Dealer Customers:

Contact your local Multiquip Dealer for parts or call 800-427-1244 for help in locating a dealer near you.



International Customers should contact their local Multiquip Representatives for Parts Ordering information.

When ordering parts, please supply:

- | | |
|---|--|
| <input type="checkbox"/> Dealer Account Number | <input type="checkbox"/> Specify Preferred Method of Shipment: |
| <input type="checkbox"/> Dealer Name and Address | <input checked="" type="checkbox"/> UPS/Fed Ex <input checked="" type="checkbox"/> DHL |
| <input type="checkbox"/> Shipping Address (if different than billing address) | <input type="checkbox"/> Priority One <input checked="" type="checkbox"/> Truck |
| <input type="checkbox"/> Return Fax Number | <input type="checkbox"/> Ground |
| <input type="checkbox"/> Applicable Model Number | <input type="checkbox"/> Next Day |
| <input type="checkbox"/> Quantity, Part Number and Description of Each Part | <input type="checkbox"/> Second/Third Day |

NOTICE

All orders are treated as *Standard Orders* and will ship the same day if received prior to 3PM PST.

WE ACCEPT ALL MAJOR CREDIT CARDS!



SAFETY INFORMATION

Do not operate or service the equipment before reading the entire manual. Safety precautions should be followed at all times when operating this equipment. Failure to read and understand the safety messages and operating instructions could result in injury to yourself and others.



SAFETY MESSAGES

The four safety messages shown below will inform you about potential hazards that could injure you or others. The safety messages specifically address the level of exposure to the operator and are preceded by one of four words: **DANGER**, **WARNING**, **CAUTION** or **NOTICE**.

SAFETY SYMBOLS

! DANGER

Indicates a hazardous situation which, if not avoided, **WILL** result in **DEATH** or **SERIOUS INJURY**.

! WARNING

Indicates a hazardous situation which, if not avoided, **COULD** result in **DEATH** or **SERIOUS INJURY**.

! CAUTION

Indicates a hazardous situation which, if not avoided, **COULD** result in **MINOR** or **MODERATE INJURY**.

NOTICE

Addresses practices not related to personal injury.

Potential hazards associated with the operation of this equipment will be referenced with hazard symbols which may appear throughout this manual in conjunction with safety messages.

Symbol	Safety Hazard
	Lethal exhaust gas hazards
	Explosive fuel hazards
	Burn hazards
	Respiratory hazards
	Accidental starting hazards
	Eye and hearing hazards
	Rotating parts hazards

SAFETY INFORMATION

GENERAL SAFETY

CAUTION

- **NEVER** operate this equipment without proper protective clothing, shatterproof glasses, respiratory protection, hearing protection, steel-toed boots and other protective devices required by the job or city and state regulations.



- **NEVER** operate this equipment when not feeling well due to fatigue, illness or when under medication.



- **NEVER** operate this equipment under the influence of drugs or alcohol.



- **ALWAYS** check the equipment for loosened threads or bolts before starting.
- **DO NOT** use the equipment for any purpose other than its intended purposes or applications.
- **ALWAYS** clear the work area of any debris, tools, etc. that would constitute a hazard while the equipment is in operation.

NOTICE

- This equipment should only be operated by trained and qualified personnel 18 years of age and older.
- Whenever necessary, replace nameplate, operation and safety decals when they become difficult read.
- Manufacturer does not assume responsibility for any accident due to equipment modifications. Unauthorized equipment modification will void all warranties.
- **NEVER** use accessories or attachments that are not recommended by Multiquip for this equipment. Damage to the equipment and/or injury to user may result.
- **ALWAYS** know the location of the nearest **fire extinguisher**.
- **ALWAYS** know the location of the nearest **first aid kit**.
- **ALWAYS** know the location of the nearest phone or **keep a phone on the job site**. Also, know the phone numbers of the nearest **ambulance, doctor and fire department**. This information will be invaluable in the case of an emergency.

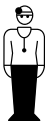

SAFETY INFORMATION

COMPACTOR SAFETY

DANGER

- **NEVER** operate the equipment in an explosive atmosphere or near combustible materials. An explosion or fire could result causing severe **bodily harm or even death.**



WARNING

- **NEVER** disconnect any **emergency or safety devices.** These devices are intended for operator safety. Disconnection of these devices can cause severe injury, bodily harm or even death. Disconnection of any of these devices will void all warranties.

CAUTION

- **NEVER** lubricate components or attempt service on a running machine.

NOTICE

- **ALWAYS** keep the machine in proper running condition.
- Fix damage to machine and replace any broken parts immediately.
- **ALWAYS** store equipment properly when it is not being used. Equipment should be stored in a clean, dry location out of the reach of children and unauthorized personnel.

ENGINE SAFETY

DANGER

- The engine fuel exhaust gases contain poisonous carbon monoxide. This gas is colorless and odorless, and can cause death if inhaled.
- The engine of this equipment requires an adequate free flow of cooling air. **NEVER** operate this equipment in any enclosed or narrow area where free flow of the air is restricted. If the air flow is restricted it will cause injury to people and property and serious damage to the equipment or engine.



WARNING

- **DO NOT** place hands or fingers inside engine compartment when engine is running.
- **NEVER** operate the engine with heat shields or guards removed.
- Keep fingers, hands hair and clothing away from all moving parts to prevent injury.
- **DO NOT** remove the radiator cap while the engine is hot. High pressure boiling water will gush out of the radiator and severely scald any persons in the general area of the compactor.
- **DO NOT** remove the coolant drain plug while the engine is hot. Hot coolant will gush out of the coolant tank and severely scald any persons in the general area of the compactor.
- **DO NOT** remove the engine oil drain plug while the engine is hot. Hot oil will gush out of the oil tank and severely scald any persons in the general area of the compactor.



CAUTION

- **NEVER** touch the hot exhaust manifold, muffler or cylinder. Allow these parts to cool before servicing equipment.



NOTICE

- **NEVER** run engine without an air filter or with a dirty air filter. Severe engine damage may occur. Service air filter frequently to prevent engine malfunction.
- **NEVER** tamper with the factory settings of the engine or engine governor. Damage to the engine or equipment can result if operating in speed ranges above the maximum allowable.
- **NEVER** tip the engine to extreme angles during lifting as it may cause oil to gravitate into the cylinder head, making the engine start difficult.





SAFETY INFORMATION

FUEL SAFETY

DANGER

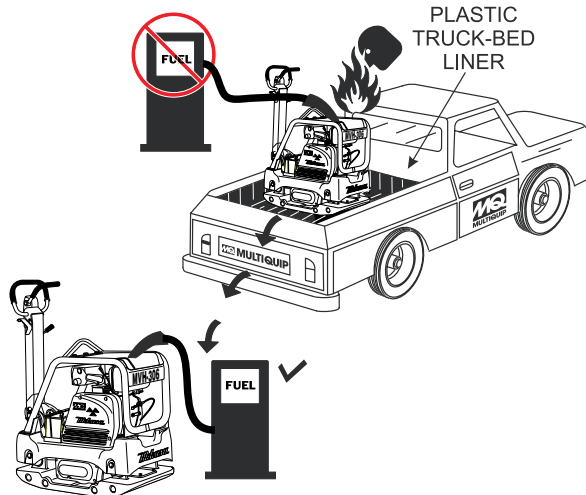
- **DO NOT** add fuel to equipment if it is placed inside truck bed with plastic liner. Possibility exists of explosion or fire due to static electricity.



- **DO NOT** start the engine near spilled fuel or combustible fluids. Diesel fuel is extremely flammable and its vapors can cause an explosion if ignited.
- **ALWAYS** refuel in a well-ventilated area, away from sparks and open flames.
- **ALWAYS** use extreme caution when working with **flammable** liquids.
- **DO NOT** fill the fuel tank while the engine is running or hot.
- **DO NOT** overfill tank, since spilled fuel could ignite if it comes into contact with hot engine parts or sparks from the ignition system.
- Store fuel in appropriate containers, in well-ventilated areas and away from sparks and flames.
- **NEVER** use fuel as a cleaning agent.
- **DO NOT** smoke around or near the equipment. Fire or explosion could result from fuel vapors or if fuel is spilled on a hot engine. 

BATTERY SAFETY (ELECTRIC START ONLY)

DANGER

- **DO NOT** drop the battery. There is a possibility that the battery will explode.
- **DO NOT** expose the battery to open flames, sparks, cigarettes, etc. The battery contains combustible gases and liquids. If these gases and liquids come into contact with a flame or spark, an explosion could occur. 

WARNING

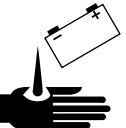
- **ALWAYS** wear safety glasses when handling the battery to avoid eye irritation. The battery contains acids that can cause injury to the eyes and skin. 
- Use well-insulated gloves when picking up the battery.
- **ALWAYS** keep the battery charged. If the battery is not charged, combustible gas will build up.
- **DO NOT** charge battery if frozen. Battery can explode. When frozen, warm the battery to at least 61°F (16°C).
- **ALWAYS** recharge the battery in a well-ventilated environment to avoid the risk of a dangerous concentration of combustible gases.
- If the battery liquid (dilute sulfuric acid) comes into contact with **clothing or skin**, rinse skin or clothing immediately with plenty of water. 
- If the battery liquid (dilute sulfuric acid) comes into contact with **eyes**, rinse eyes immediately with plenty of water and contact the nearest doctor or hospital to seek medical attention.

CAUTION

- **ALWAYS** disconnect the **NEGATIVE** battery terminal before performing service on the equipment.
- **ALWAYS** keep battery cables in good working condition. Repair or replace all worn cables.

SAFETY INFORMATION

TRANSPORTING SAFETY

CAUTION

- NEVER allow any person or animal to stand underneath the equipment while lifting.

NOTICE

- Before lifting, make sure that the equipment parts (hook and vibration insulator) are not damaged and screws are not loose or missing.
- Always make sure crane or lifting device has been properly secured to the lifting bail (hook) of the equipment.
- **ALWAYS** shutdown engine before transporting.
- **NEVER** lift the equipment while the engine is running.
- Tighten fuel tank cap securely and close fuel cock to prevent fuel from spilling.
- Use adequate lifting cable (wire or rope) of sufficient strength.
- Use one point suspension hook and lift straight upwards.
- **DO NOT** lift machine to unnecessary heights.
- **ALWAYS** tie down equipment during transport by securing the equipment with rope.

ENVIRONMENTAL SAFETY/DECOMMISSIONING

NOTICE

Decommissioning is a controlled process used to safely retire a piece of equipment that is no longer serviceable. If the equipment poses an unacceptable and unrepairable safety risk due to wear or damage or is no longer cost effective to maintain (beyond life-cycle reliability) and is to be decommissioned (demolition and dismantlement), be sure to follow rules below:

- **DO NOT** pour waste or oil directly onto the ground, down a drain or into any water source.
- Contact your country's Department of Public Works or recycling agency in your area and arrange for proper disposal of any electrical components, waste or oil associated with this equipment.



- When the life cycle of this equipment is over, remove battery and bring to appropriate facility for lead reclamation. Use safety precautions when handling batteries that contain sulfuric acid.

- When the life cycle of this equipment is over, it is recommended that the trowel frame and all other metal parts be sent to a recycling center.

Metal recycling involves the collection of metal from discarded products and its transformation into raw materials to use in manufacturing a new product.

Recyclers and manufacturers alike promote the process of recycling metal. Using a metal recycling center promotes energy cost savings.

EMISSIONS INFORMATION

NOTICE

The diesel engine used in this equipment has been designed to reduce harmful levels of carbon monoxide (CO), hydrocarbons (HC) and nitrogen oxides (NOx) contained in diesel exhaust emissions.

This engine has been certified to meet US EPA Evaporative emissions requirements in the installed configuration.

Attempting to modify or make adjustments to the engine emission system by unauthorized personnel without proper training could damage the equipment or create an unsafe condition.

Additionally, modifying the fuel system may adversely affect evaporative emissions, resulting in fines or other penalties.

Emission Control Label

The emission control label is an integral part of the emission system and is strictly controlled by regulations.

The label must remain with the engine for its entire life.

If a replacement emission label is needed, please contact your authorized Kohler Engine Distributor.

SPECIFICATIONS

Table 1. MVH406DSZ/DSCPAS Reversible Plate Compactor Specifications	
Centrifugal Force	12,346 lbs. (5,600 kg)
Vibration Frequency	4,600 vpm (77 Hz)
Traveling Speed	0 to 75 ft/min (0 to 23 m/min)
Plate Size (L x W)	35.43 x 19.69 in (90 x 50 cm)
External Plate Size (L x W)	35.43 x 25.59 in (90 x 65 cm)
Max. Area of Compaction (no extensions)	7,510 sq. ft. (2,289 sq. meters)
Length (handle in working position)	63.39 in (1610 mm)
Height (handle in working position)	41.34 in (1050 mm)
Length (handle in vertical position)	37.6 in (955 mm)
Height (handle in vertical position)	55.12 in (1400 mm)
Operating Weight (without extension plates)	903.88 lbs. (410 kg)
Operating Weight (with extension plates)	948 lbs. (430 kg)
Lubricating Oil in Vibration Case	20.28 fl. oz. (600 cc)

Table 2. Engine Specifications	
Engine Make	FUJI HEAVY INDUSTRIES
Engine Model	Robin D1B40T92040
Engine Type	10 HP, Air-cooled 4-cycle Diesel Engine
Cylinder Bore X Stroke	3.5 x 3.45 in (88 x 76 mm)
Displacement	15.6 fl oz (462 cm ³)
Maximum Output	9.6 HP @3,200 RPM (7.2 kw @3,200 RPM)
Fuel Tank Capacity	5.2 quarts (5.0 liters)
Oil Capacity	1.6 quarts (1.55 liters)
Starting Method D/DS	Recoil/Electric
Dry Net Weight Recoil/Electric	118.3 lbs. (53.3 kg)
Dimensions (L x W x H)	12.40 x 15.51 x 18.89 in (315 x 394 x 480 mm)

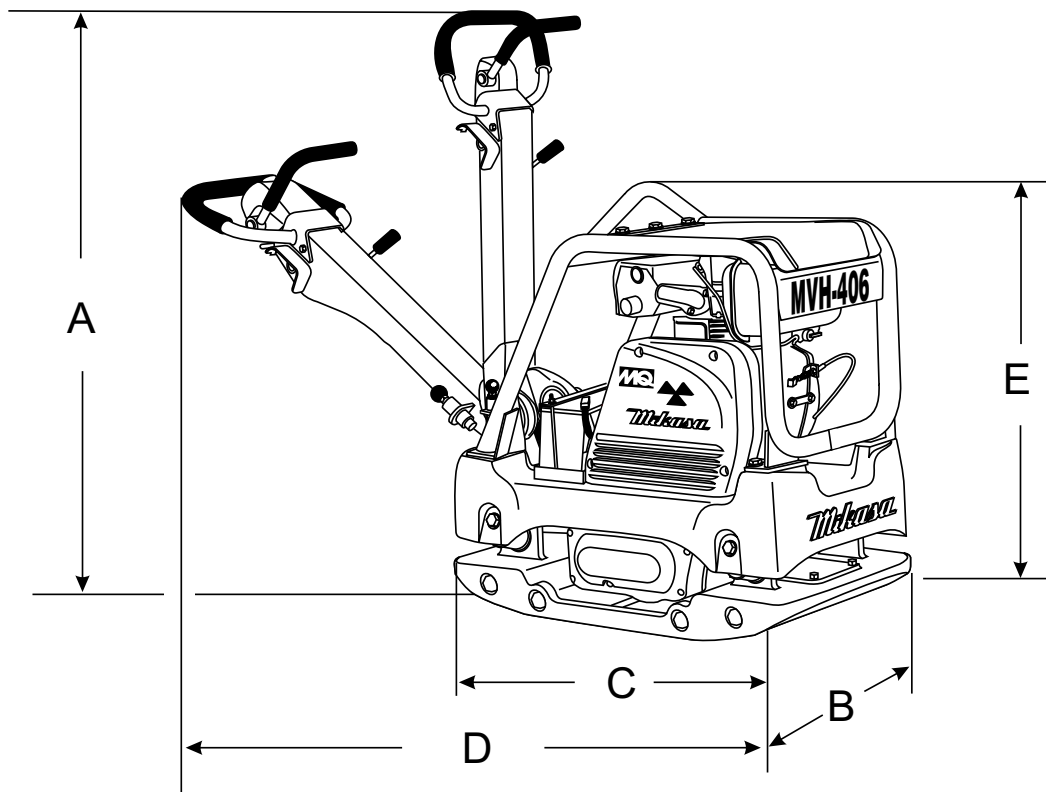

Figure 1. MVH406DSZ/DSCPAS Reversible Plate Compactor Dimensions

Table 3. Dimensions	
A	55.12 in. (140 mm.)
B	19.69 in. (50 cm.)
C	35.3 in. (90 cm.)
D	63.39 in. (161 cm.)
E	41.34 in. (105 cm.)

Plate Compactor

The Mikasa MVH406DSZ/DSCPAS is a walk behind, reversible plate compactor designed for the compaction of sand, clay and asphalt. This plate compactor is a powerful compacting tool capable of applying a tremendous force in consecutive high frequency vibrations to a soil surface. Its applications include soil compacting for road, embankments and reservoirs as well as backfilling for gas pipelines, water pipelines and cable installation work.

Vibratory Plates

The vibratory plates of this plate compactor produce low amplitude high frequency vibrations, designed to compact granular soils.

The resulting vibrations cause forward motion. The engine and handle are vibration isolated from the vibrating plate. The heavier the plate, the more compaction force it generates.

Reversible Vibratory Plates

Reversible vibratory plates have two eccentric weights that allow a smooth transition for forward and reverse travel, plus increased compaction force as the result of dual weights.

Due to their weight and force, reversible plates are ideal for semi-cohesive soils.

Frequency/Speed

The compactor's vibrating plate maximum frequency is 4600 vpm (vibrations per minute). The forward and reverse travel speed of the compactor is approximately 75 ft./minute (23 meters/minute).

Engine

This plate compactor is equipped with a ROBIN 1B40, 10 HP, air-cooled 4-cycle diesel engine.

Controls

Before starting this plate compactor, identify and understand the function of the controls and all components.

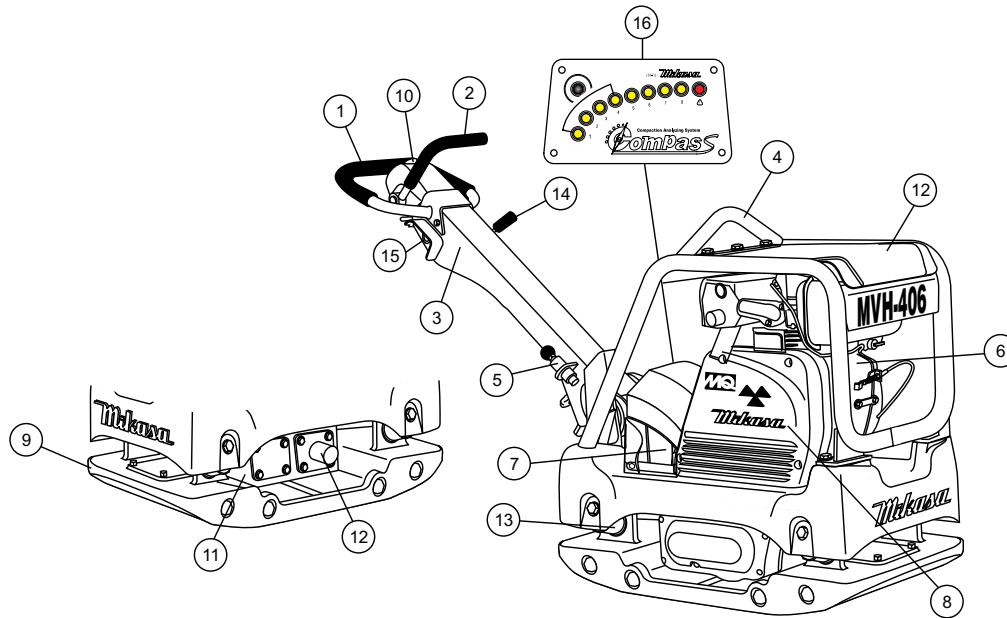

Figure 2. MVH406DSZ/DSCPAS Reversible Plate Compactor Components

Figure 2 illustrates the location of the major components for the MVH406DSZ/DS2CPAS Reversible Plate Compactor. The function of each component is described below:

1. **Hand Grip** – When operating the compactor use this hand grip to maneuver the compactor.
2. **Forward & Reverse Lever** – Push the lever forward, the compactor will move in a forward direction, pull the lever backwards, the compactor will move in backwards direction. Placing the lever in the middle (midway) will cause the compactor not to move (neutral).
3. **Handle Bar** – When operating the compactor, this handle is to be in the downward position. When the compactor is to be stored, move the handle bar to the upright position.
4. **Guard Hook** - Used to lift the machine with crane or other lifting device.
5. **Stopper** - Locks the handle in place in the upward position for stowing.
6. **Engine** – This plate compactor uses a ROBIN D1B40T92040 diesel engine. Refer to the owner's manual for engine information and related topics.
7. **Battery (Option)** - This unit uses a 12-volt battery. See maintenance of this manual for proper care of battery.
8. **Belt Cover** – Remove this cover to gain access to the V-belts. **NEVER** run the compactor without the V-belt cover. If the V-belt cover is not installed, the possibility exist that your hand may get caught between the V-belt and clutch, thus causing serious injury and bodily harm.
9. **Base Plate** – Designed to compact sand, clay, and asphalt.
10. **Oil Reservoir** – Fill with Shell Tellus Oil 46 or equivalent grade hydraulic oil.
11. **Vibration Case** – Encloses the eccentric, gears and counter weights.
12. **Hydraulic Cylinder** – Activated by moving the travel lever. The cylinder controls the direction of movement by the plate compactor.
13. **Shock Absorber** – Protects plate compactor from damage by absorbing vibration during operation.
14. **Throttle Lever** – Controls speed of the plate compactor. Place straight vertically to start, push fully counterclockwise for full throttle and fully clockwise to stop plate compactor.
15. **Ignition Switch (Option)** – Provided for electric start models only.
16. **COMPAS** – Compaction Analysing System, monitors soil stiffness. Available only on the MVH406DSCPAS.

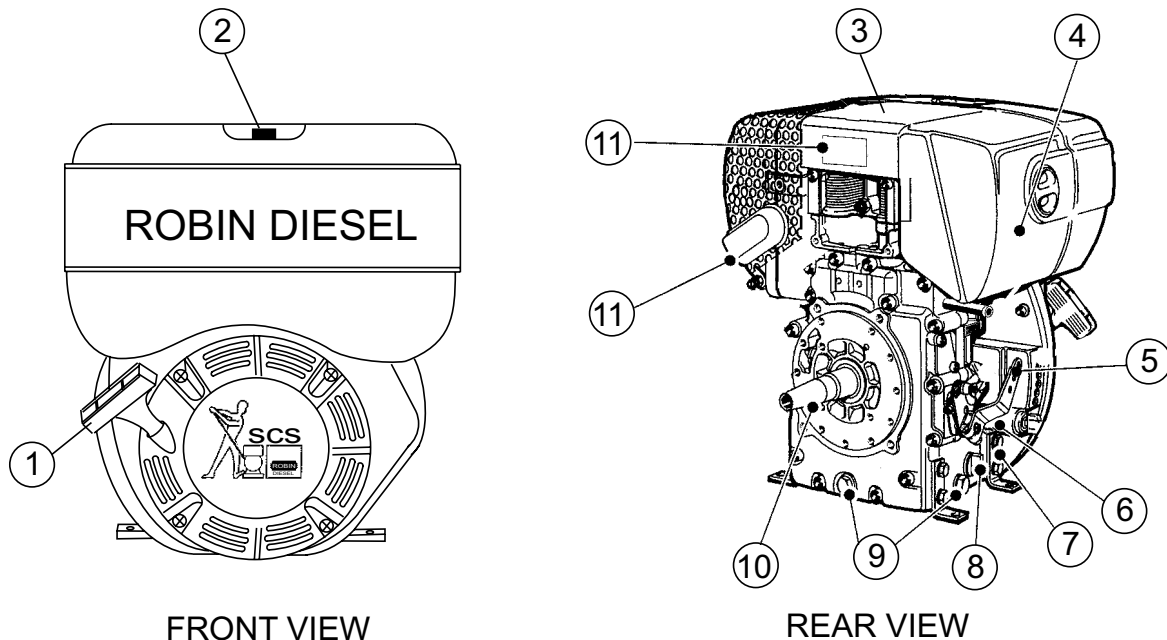

Figure 3. Robin D1B40T92040 Diesel Engine Components

ENGINE COMPONENTS

Figure 3 illustrates the location of the major components for the ROBIN D1B40T92040 diesel engine. The function of each component is described below

1. **Recoil Starting Handle (pull rope)** – Type of engine starting method. Alternate type would be electric start (ignition key).
2. **Fuel Filler Cap/Fuel Tank** – Remove this cap to add diesel fuel to the fuel tank. Make sure cap is tighten securely. **DO NOT** over fill. Fuel tank capacity is 5.3 quarts (5.0 liters)..
3. **Engine Lifting Straps/Cover** – Remove the air cleaner cover, then lift this cover (the one with decals on it) to gain access to the engine lifting straps.
4. **Air Cleaner/Cover** – Prevents dirt and other debris from entering the fuel system. Remove wing-nut on top of air filter canister to gain access to filter element.
5. **Speed Control Lever** – This lever is connected to the throttle control which is located on the compactor handle bar. This lever to controls engine speed.
6. **Oil Filler Cap / Dipstick** – Remove this cap to add oil to the engine crankcase. Read dipstick to determine if oil level is low. **DO NOT** over fill lever to control engine speed. Engine oil capacity is 1.6 quarts (1.55 liters).
7. **Engine Motor Mounts** – Secure these engine mounts to the compactor frame. Tighten securely.
8. **Oil Suction Filter** – Remove this bolt to gain access to the internal oil suction filter. Service the oil suction filter as recommended in the maintenance section of this manual.
9. **Oil Drain Plug** – Unscrew plug to drain oil from engine crankcase. Dispose of oil in a safe manner.
10. **Crankshaft** – Connect this shaft to the input of the transmission.
11. **Muffler** – Used to reduce noise and emissions.
12. **Engine Nameplate** – Contains information about the engine.

Before Starting

1. Read safety instructions at the beginning of manual.
2. Familiarize yourself with the operating and control elements of the machine and the working environment. This includes obstacles in the working area, bearing capacity of the ground and the necessary safety provisions.
3. Check the air filter for dirt and dust. If air filter is dirty, replace air filter with a new one as required.
4. Check fastening nuts and bolts for tightness. Loose threads may cause damage to the machine when vibrating.
5. Understand the geographical features and regulations of the job site.
6. Clean the compactor, removing dirt and dust. Particularly, the bottom of the plate, engine cooling air inlet.

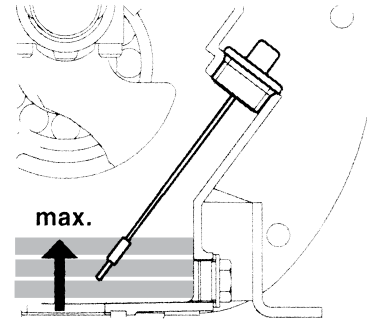

Figure 5. Engine Oil Level

Checking Engine Oil Level

1. To check the engine oil level, place the compactor on secure level ground with the engine stopped.
2. Remove the dipstick from the engine oil filler hole (Figure 4) and wipe it clean.
3. Insert and remove the dipstick without screwing it into the filler neck. Check the oil level shown on the dipstick.

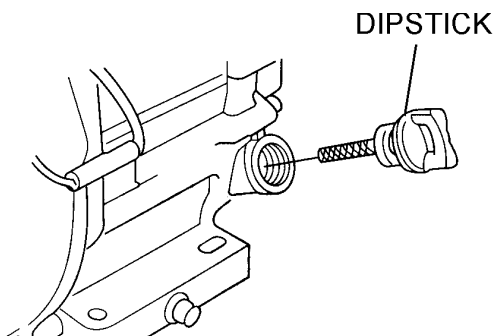

Figure 4. Engine Oil Dipstick Removal

4. If the oil level is low (Figure 5), fill to the edge of the oil filler hole with the recommended oil type (Table 4). Maximum oil capacity is 1.16 quarts (1.10 liters).

Table 4. Oil Type

Season	Temperature	Oil Type
Summer	25°C or Higher	SAE 10W-30
Spring/Fall	25°C~10°C	SAE 10W-30/20
Winter	0°C or Lower	SAE 10W-10

Checking the Hydraulic Oil Level

1. To check the engine oil level, place the compactor on secure level ground with the engine stopped.
2. Remove the hydraulic oil breather cap located at the top of the hydraulic oil tank (Figure 6).
3. Using a 24 mm wrench, remove the hydraulic oil filler plug.
4. Visually inspect to determine if hydraulic oil level is low. If oil level is low add Shell Tellus 32 hydraulic oil or equivalent through the hand pump oil filler port.

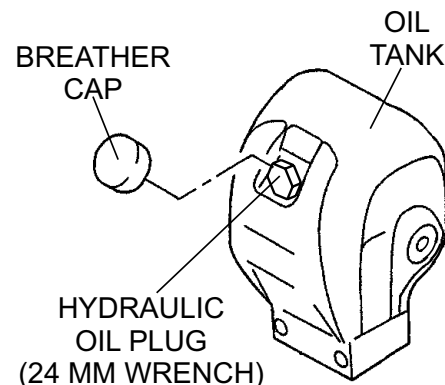

Figure 6. Hydraulic Oil Filler Plug Removal

CAUTION

DO NOT overfill hydraulic oil tank. This could cause oil leaks and sluggish operation. Clean cap and surrounding area before opening to prevent dirt from entering oil tank.

- When adding hydraulic oil, only fill to the specified oil level as marked on the front of the hydraulic oil tank (Figure 7). **DO NOT** overfill.

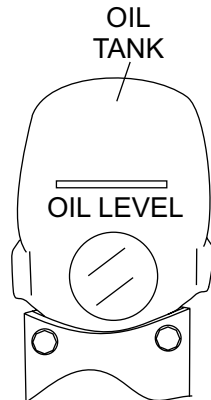

Figure 7. Oil Tank (Front View)

Checking the Air Cleaner

- To check the engine oil level, place the compactor on secure level ground with the engine stopped.
- Loosen the wing nut (Figure 8), remove the air cleaner cover.

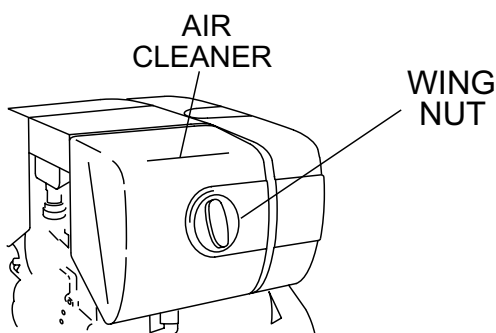

Figure 8. Checking the Air Cleaner

- Remove the air cleaner element (Figure 9) and inspect it for signs of wear or dirt. If air cleaner element is dirty, clean or replace element.

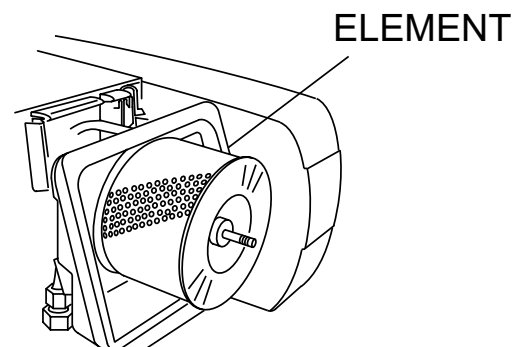

Figure 9. Air Cleaner Element

DANGER



EXPLOSIVE FUEL!

Motor fuels are highly flammable and can be dangerous if mishandled. **DO NOT** smoke while refueling. **DO NOT** attempt to refuel if the engine is hot or running.

Checking The Fuel

- Remove the fuel cap located on top of fuel tank.
- Visually inspect to see if fuel level is low. If fuel is low, replenish with diesel fuel (Figure 10).
- When refueling, be sure to use a strainer for filtration. **DO NOT** top-off fuel. Wipe up any spilled fuel.

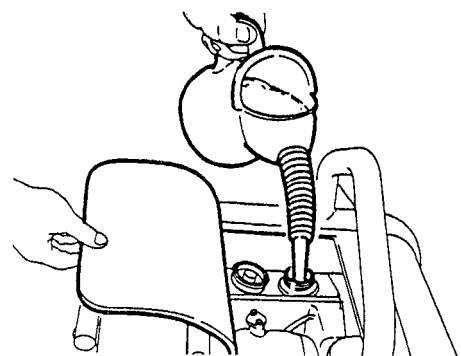

Figure 10. Refueling

CAUTION



DO NOT attempt to operate the compactor until the Safety, General Information and Inspection sections of this manual have been read and thoroughly understood.

This section is intended to assist the operator with the initial start-up of the compactor. It is extremely important that this section be read carefully before attempting to use the compactor in the field.

Refer to Figure 3 for the location of controls and components.

Releasing the Handle

1. Pull the handle release pin, (Figure 11) then push down on the hand grip to release the handle.

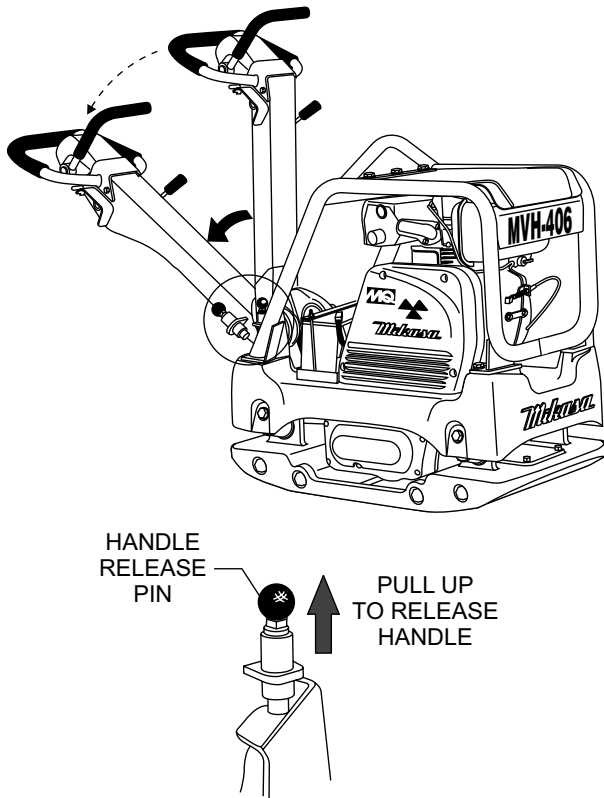

Figure 11. Handle Release Pin

Adjusting Handle Height

The height of the handle is adjustable for your comfort .

1. Loosen the butterfly screw (Figure 12).
2. Turn the grip clockwise to raise the handle or counterclockwise to lower the handle.
3. When the handle is raised to the desired height, tighten the butterfly screw.

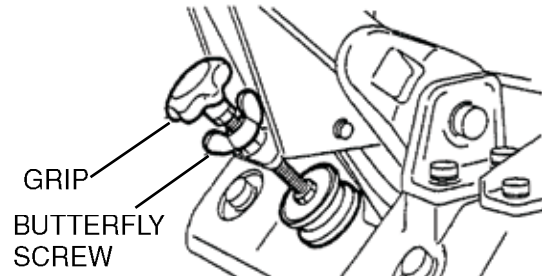

Figure 12. Handle Adjustment

STARTING THE ENGINE

Electric Start (Option)

4. Place the throttle lever (Figure 13) in the START position (center). Place the travel lever in the neutral position (center).

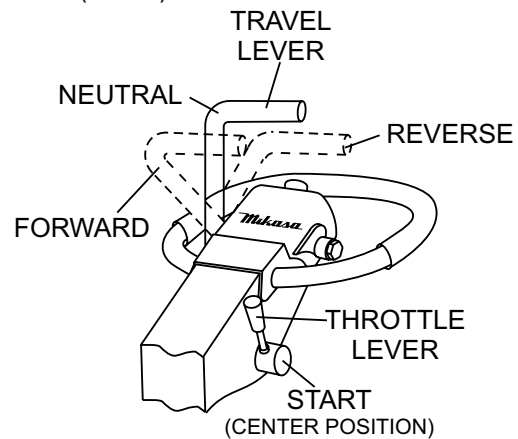

Figure 13. Travel/Throttle Lever (Start Position)

5. Insert the ignition key into the ignition switch and turn it to the **RUN** position (Figure 14). The buzzer should sound at this time.
6. Turn the ignition key further to the right to the **START** position to start the engine. Buzzer stops sounding and the engine starts.

- If the engine fails to start, **DO NOT** continue to rotate the ignition key for more than 5 seconds. Return the key to the **RUN** position and wait 10 seconds before starting again

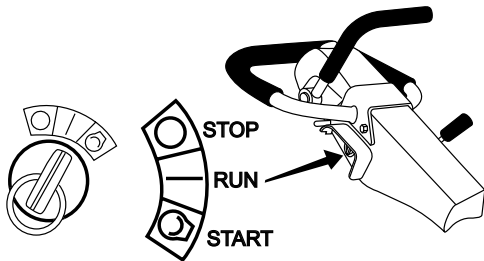

Figure 14. Starter Switch (Option)

CAUTION

While the engine is running, never try to turn the ignition key to the **START** position.

- After starting the engine, continue to warm up the engine for about 3 to 10 seconds especially in cold weather.
- If the buzzer does not stop sounding after the engine has started, shutdown engine immediately and check engine oil level. The buzzer functions as a engine oil level alarm warning device.

Recoil Start

- Place the throttle lever (Figure 13) in the **START** position (center).
- Place the travel lever in the neutral position (center).
- Grasp the starter grip (Figure 15) and slowly pull it out. The resistance becomes the hardest at a certain position, corresponding to the compression point. Pull the starter grip briskly and smoothly for starting.

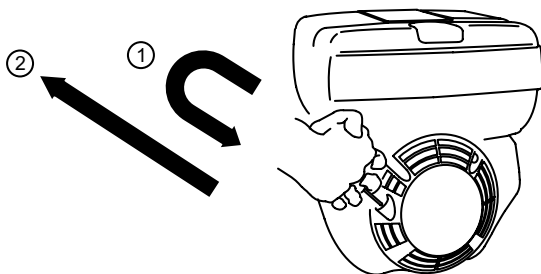

Figure 15. Engine Start Handle

- If the engine does not start, repeat steps 1 through 3.

TRAVELING

CAUTION

Make sure to follow all safety rules referenced in the safety section of this manual before operating compactor. Keep work area clear of debris and other objects that could cause damage to the compactor or bodily harm.

- Grasp the compactor's hand grip, and move the engine throttle lever (Figure 16) quickly to the fast position.
- With the throttle lever in the fast position, the engine speed should be around 3,600 RPM, therefore engaging the centrifugal clutch.

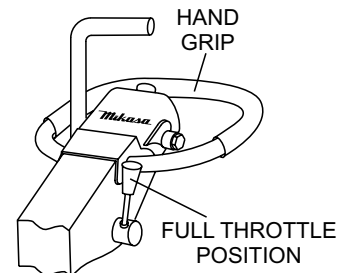

Figure 16. Throttle Lever (Fast)

NOTICE

ALWAYS move the throttle lever quickly without hesitation, because increasing the engine speed slowly causes the clutch to slip.

- To make the compactor move in the forward direction push the travel lever (Figure 17) forward.

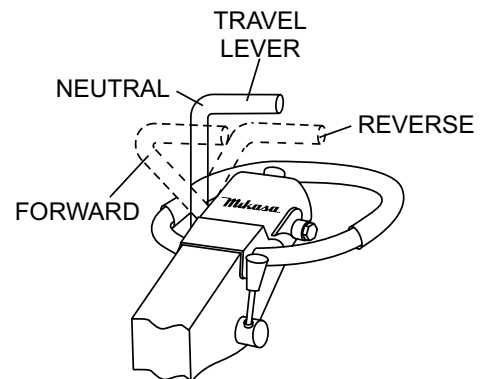

Figure 17. Travel Lever

4. To make the compactor move in the reverse direction pull the travel lever (Figure 17) backwards.
5. Firmly grasp the compactor's hand grip, the compactor will begin moving in the desired position when the direction lever has been placed in the desired position.
6. Slowly walk behind the compactor and be on the lookout for any large objects or foreign matter that might cause damage to the compactor or bodily injury.
7. If travel lever is placed in the neutral position, the machine will vibrate in place.
8. To move the compactor laterally, hold the hand grip firmly and swing compactor. **DO NOT** swing compactor while gripping the travel lever.

Normal Shutdown

1. Return the throttle lever to the **START** position (Figure 13). Allow the machine to cool down for 2 to 3 minutes.
2. Place the travel lever in the **NEUTRAL** position (Figure 18).
3. Place the throttle lever in the **STOP** position (Figure 18) to stop the engine.

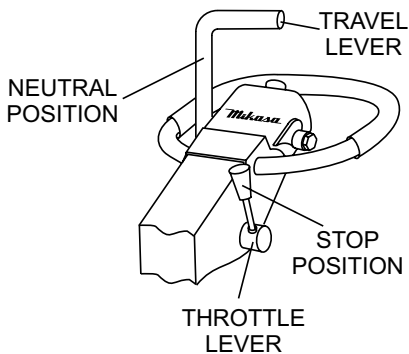

Figure 18. Throttle Lever (Stop)

4. If using an electric start unit, return the key switch to the **STOP** position (Figure 19) as soon as the engine stops.

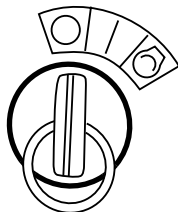

Figure 19. Starter Switch (STOP)

Emergency Shutdown

1. For a recoil start type engine, move the throttle lever quickly to the **STOP** position.
2. For an electric start type engine, place the engine ignition switch in the **OFF** position.

Stowing the Handle

1. Push up the handle upward (Figure 20) until the handle locks in place.

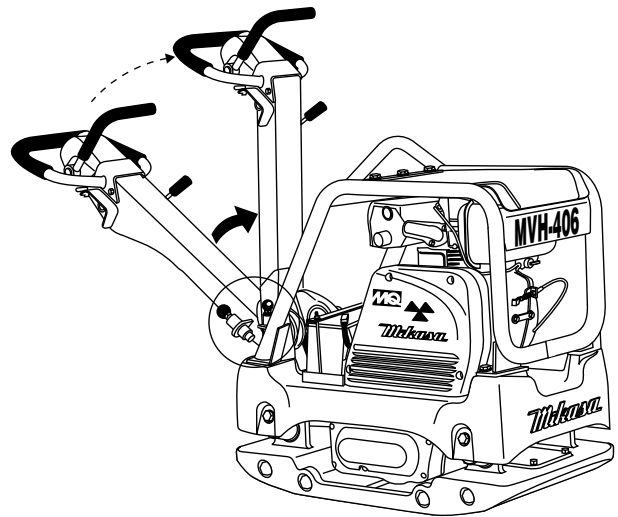

Figure 20. Stowing The Handle

COMPACTION SENSOR (MVH406 DSCPAS Only)

Compaction Analyzing System (COMPAS) is a system that uses an acceleration sensor to show real-time soil stiffness via LED's (light-emitting diode) turning on with each pass of the compactor.

This COMPAS improves compaction work efficiency because it can prevent an already properly compacted area from being compacted more than necessary and identify an area where more compaction is needed.

COMPAS also has a function to detect abnormalities such as vibration trouble (insufficient vibration frequency), ground trouble (soft soil) and other functional issues (Figure 21).

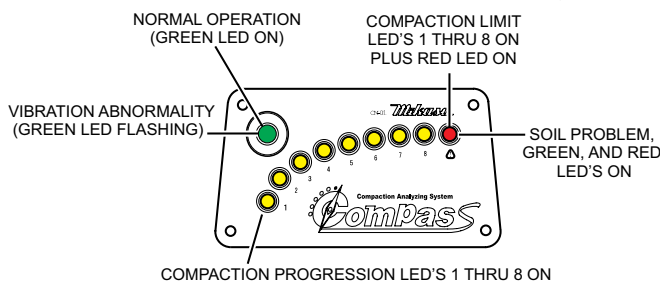

Figure 21. Compaction Sensor (COMPAS)

NOTICE

COMPAS can only show progression of the soil stiffness and is not meant to measure absolute soil density. When using COMPAS always calculate appropriate soil density by conducting proper testing such as plate load test and dynamic load test to best compliment the LED lighting progression with the actual measurement value.

Normal Compaction (Compaction Progression)

NOTICE

Not all yellow status LEDs will turn on. The progression of the yellow status LEDs depends on the type of soil being compacted. If compacting gravel (stiff soil) **potentially** all status LEDs will turn ON.

If compacting sand (soft soil), fewer status LED's will turn ON. Remember **DO NOT** over compact.

When the plate compactor is in idle mode the **green** LED will begin flashing and the **red** LED will turn on. As the engine RPM's are increased and compaction begins, the **green** LED will stop flashing and turn on (solid). The **red** LED will turn off and the #1 **yellow** LED will turn on. As compaction progresses the number of yellow LEDs, 2 thru 8 will turn on (Figure 22).

The number of yellow status LEDs that will turn on is soil dependent.

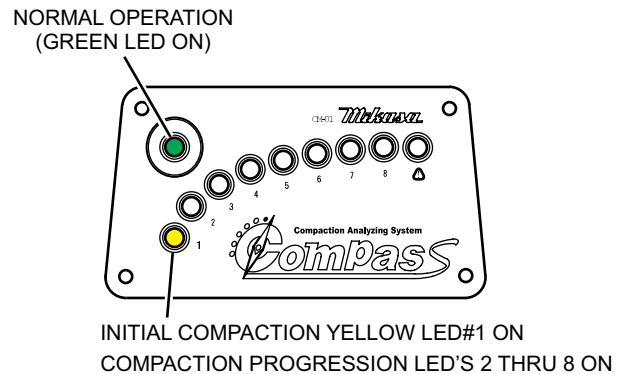

Figure 22. Compaction Progression

Normal Compaction (Compaction Limit)

The compaction limit (Figure 23) is achieved when all the yellow LED's 1 thru 8 including the red LED are all on, depending on type of soil being compacted . At this point the machine cannot compact any further. If the compaction results are not satisfactory then check and make sure the soil type, moisture content, lift and number of passes are proper for this machine.

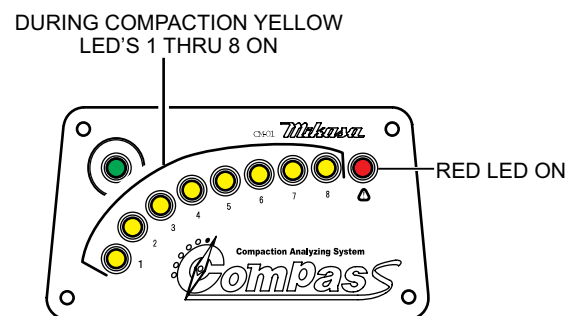

Figure 23. Compaction Limit

System Diagnostics to Detect Operational Abnormalities

Detection of ground trouble and soft ground

1. For a case of unstable ground or soft ground (soil containing high clay content) for which the use of this machine is not suitable, only the green and red LEDs will be on (Figure 24), with no yellow LED's on.

If this occurs it would be challenging to achieve the desired compaction results. Check to make sure the ground conditions are prepared to specification before proceeding with the compaction process.

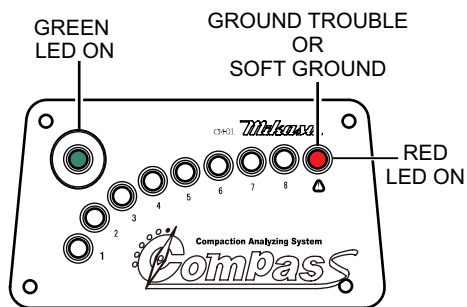

Figure 24. Ground Trouble or Soft Ground

Detection of Vibration Abnormality

2. When appropriate vibration frequency cannot be achieved during operation due to improper engine RPMs (Figure 25) the green LED will flash. When this occurs check the engine RPMs and the V-belt tension as it could be loose.

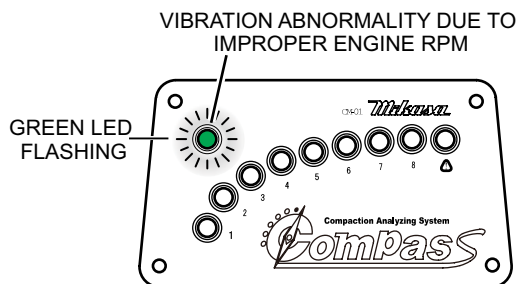

Figure 25. Vibration Abnormality Improper Engine RPM's

Function to Detect Electric System Abnormality

Sensor wire disconnection (between acceleration sensor and sensor panel)

3. If red and green LEDs are flashing alternately as shown in Figure 26 then please check the sensor wire because there is a possibility that it is disconnected.

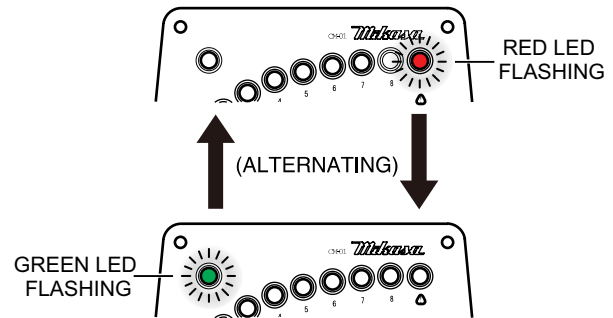

Figure 26. Sensor Wire Disconnection

Power cable disconnection (between battery and sensor panel)

4. If there are no LEDs on or flashing even when the key switch is turned on then please check the power cable because there is a possibility it is disconnected.

CAUTION

Inspection and other services should always be carried out on hard and level ground with the engine shutdown.

Inspection and Maintenance Service Tables.

To make sure your plate compactor is always in good working condition before using, carry out the maintenance inspection in accordance with Table 5 thru Table 7.

Table 5. Machine Inspection

Item	Hours of Operation
Loose or Missing Screws	Every 8 hours (every day)
Damaged Parts	Every 8 hours (every day)
Function of Controlling System Part	Every 8 hours (every day)
Hydraulic System Leak	Every 100 hours
Vibrator Oil Check Every	Every 100 hours
Vibrator Oil Replacement	Every 300 hours
Hydraulic Oil Check Every	Every 100 hours
Hydraulic Oil Replacement	First after 200 hours, then every 1,000 hours
V-belt (clutch) Check	Every 200 hours
Battery Check	Every 100 hours

CAUTION

These inspection intervals are for operation under normal conditions. Adjust your inspection intervals based on the number hours plate compactor is in use, and particular working conditions.

NOTICE

Fuel piping and connections should be replaced every 2 years.

Table 6. Engine Check

Item	Hours of Operation
Oil or Fuel Leak	Every 8 hours (every day)
Tightness of Fastening Threads	Every 8 hours (every day)
Engine Oil Check and Replenishment	Every 8 hours (every day) (Replenish to specified maximum level)
Engine Oil Replacement	After first 25 hours then every 50 to 100 hours
Air Filter Cleaning Every	100 hours
See separate engine manual for details on engine check.	

Daily Service

- Check for leakage of fuel or oil.
- Check for loose screws including tightness. See Table 7 below (tightening torque), for retightening:

Table 7. Tightening Torque (in. kg/cm) Diameter

Material	6mm	8mm	10mm	12mm	14mm	16mm	18mm	20mm
4T	70	150	300	500	750	1,100	1,400	2,000
6-8T	100	250	500	800	1,300	2,000	2,700	3,800
11T	150	400	800	1,200	2,000	2,900	4,200	5,600
*	100	300~ 350	650~ 700					

* (In case counter-part is of aluminum)
(Threads in use with this machine are all right handed)
Material and quality of material is marked on each bolt, and screw.

- Remove soil and clean the bottom of compaction plate.
- Check hand pump, piping and hose for any leakage. A loosened hydraulic hose can be a cause for leakage. Check hydraulic hose connections with wrench applied for tightness.
- Check engine oil.

Engine Oil Replacement:

1. Replace engine oil, in first 25 hours of operation and every 50 to 100 hours afterwards.
2. Oil may be drained more easily when it is warm afteroperation (For more details, see separate engine Owner's Manual).

Air Filter (Every 6 Months or 400 Hours)

1. The air filter element (Figure 27) should be cleaned because a clogged air cleaner can cause poor engine starting, lack of power and shorten engine life substantially.

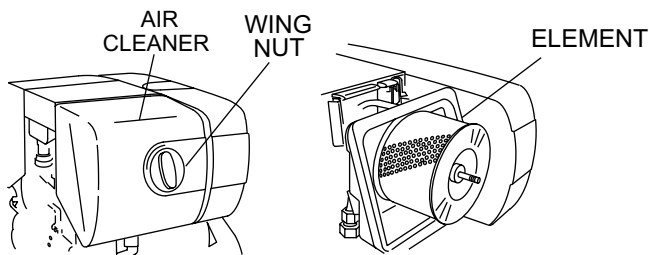

Figure 27. Engine Air Filter and Element

2. To clean or replace air filter loosen the wing nut on the air filter housing (Figure 27) remove the cover and take out air filter cartridge. If only cleaning of the air filter is desired blow through the air filter cartridge from the inside, moving a jet of dry compressed air up and down until all dust is removed.

CAUTION

NEVER attempt to check the V-belt with the engine running. Severe injury can occur if your hand gets caught between the V-belt and the clutch (Figure 28). Always use safety gloves.

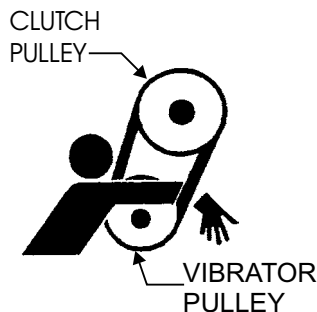

Figure 28. V-Belt Hazard

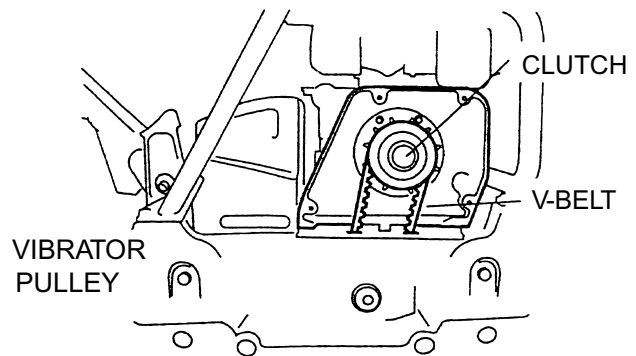

Figure 29. V-Belt Check

Replacing the V-belt

- Remove the belt cover (Figure 29). Engage an offset wrench 3/4" (19 mm) or the like to vibrator pulley (lower) fastening bolt. Engage wastecloth or the like at midway of V-belt on the left side and while pulling it back strongly, rotate the offset wrench clockwise so that the V-belt will come off.

Reinstalling the V-belt

- Engage V-belt to lower vibrator pulley and push the V-belt to leftside of upper clutch and, in the same manner as in removal, rotate offset wrench clockwise so that the V-belt goes back on.

Checking Clutch

- Check the clutch simultaneously with V-belt checking. With belt cover removed, check outer drum of the clutch for seizure and "V" groove for wear or damage with your eyes. Clean the "V" groove as necessary. If the shoe is worn, power transmission becomes deficient and slipping will result.

Replacing Clutch

- Remove V-belt. Remove bolt at engine power output by giving a light tap with a hammer to an engaged wrench and rotate bolt counterclockwise. Remove clutch with a pulley extractor. To reinstall, reverse the procedure.

CAUTION

When ever the compactor's vibration becomes weak or lost during normal operation regardless of operation hours, check the V-belt and clutch immediately.

Vibrator Oil Level Check

NOTICE

ALWAYS clean the area around the vibrator oil level check plug before removing oil check plug. This will prevent dirt and debris from entering the system.

1. In every 100 hours of operation, with the machine positioned horizontally, use a 3/4" (19 mm) wrench and remove vibrator oil level gauge/dipstick (Figure 30). Visually inspect and see if vibrator oil level is up to filler port. Be sure to clean area around check hole to prevent dirt and dust from entering.

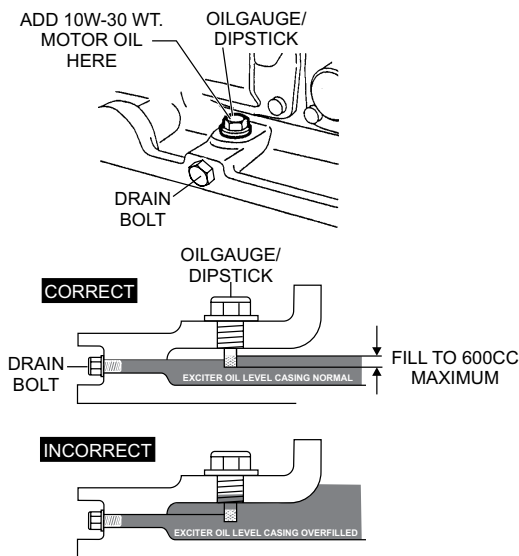

Figure 30. Vibrator Oil Drain and Check Plugs

NOTICE

The oil fill gauge (dipstick) should be threaded down completely when checking the oil level. Quickly inserting and removing the dipstick from the reservoir will provide inaccurate readings and possibly lead to overfilling the exciter casing.

Overfilling the exciter casing will overload the engine and adversely affect performance. **DO NOT OVERFILL 600CC Maximum oil level!**

Draining Vibrator Oil

1. Replace vibrator oil after first 200 hours and in every 1,000 hours of operation.
2. Position handle bar vertically (storage position).
3. Using a 14 mm wrench remove the vibrator oil drain plug (Figure 30) from the vibrating plate assembly.

NOTICE

For draining oil through level check hole, have the machine inclined with a sleeper or the like placed under the compaction plate on opposite side.

4. After hydraulic oil has been completely drained from machine, fill with 10W-30 motor oil to the appropriate safe operating level (Figure 30).
5. Reinstall drain plug into vibrating plate assembly. Apply seal tape or Loctite #575 to thread portion of drain plug.

Draining Hydraulic Oil

1. Disconnect the hydraulic hose (Figure 31) connected to the hydraulic oil cylinder.
2. Push the travel lever back and forth to drain the hydraulic oil from the hand pump (hydraulic oil reservoir).

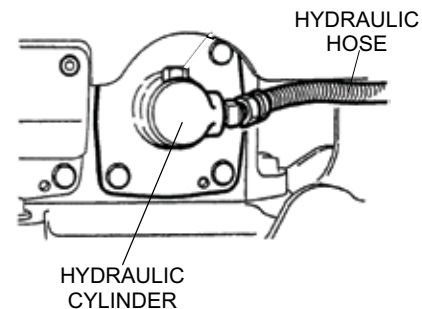

Figure 31. Hydraulic Oil Cylinder/Hose

3. After draining hydraulic oil, reconnect hydraulic oil hose to cylinder.
4. Place handle in upright position. Pull travel lever all the way back (reverse), and using a rope, secure travel lever to hand grip.

Adding Hydraulic Oil

1. Remove the breather cap and oil plug (Figure 32) from the hydraulic oil tank using a 24mm hex socket.

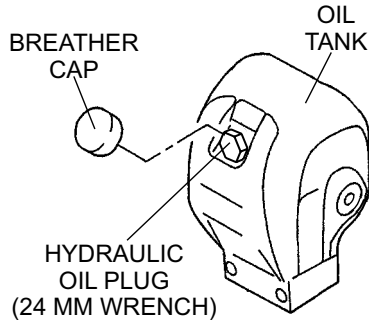

Figure 32. Hydraulic Oil Tank

2. Using a funnel, add Shell Tellus Oil #32 or equivalent to the hydraulic oil tank through the oil filler port (Figure 33). Oil tank capacity is 18.7 fl. oz (550 cc).

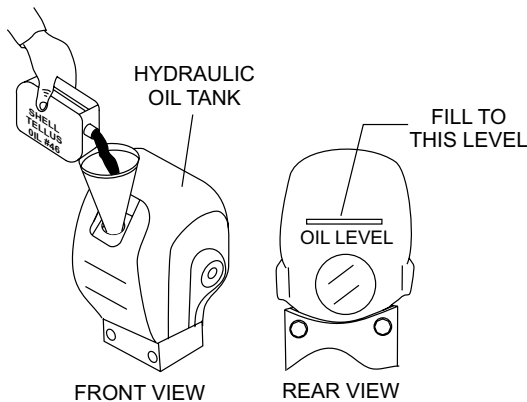

Figure 33. Adding Hydraulic Oil

CAUTION

Make sure hydraulic oil is at a normal safe operating level. **DO NOT** over fill. Over filling (excessive oil) will cause excess oil to blow out of breather plug.

3. Loosen bleeder plug located at top of hydraulic cylinder on side of vibrator (Figure 34). Air remaining in the circuit will be forced out of the bleeder plug. Once all air has been purged from the hydraulic system, tighten bleeder plug securely
4. Reinsert oil plug into hydraulic oil tank and tighten securely. Reinstall breather cap.

NOTICE

The bleeder plug should only be loosened, but not removed.

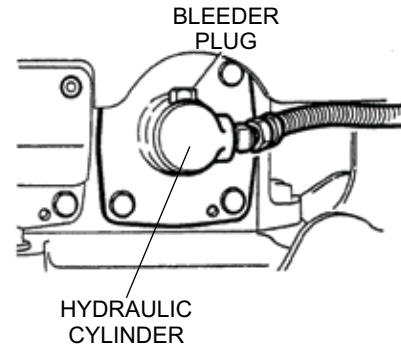

Figure 34. Bleeder Plug

CAUTION

ALWAYS wear safety glasses or face mask, protective clothes, and rubber gloves when working with battery.

BATTERY MAINTENANCE (Option)

Mishandling of the battery shortens the service life of the battery and adds to maintenance cost. When handling the battery do the following:

- The battery electrolyte contains sulfuric acid, be careful not to let the battery electrolyte come in contact with your body or clothing.
- Always check the battery terminals periodically to ensure that they are in good condition.
- Always wear eye protection and rubber gloves, since the battery contains sulfuric acid which burns skin and eats through clothing. In case of contact, flush thoroughly with water and contact a doctor immediately.
- Use wire brush or sand paper to clean the battery terminals.
- Always check battery for cracks or any other damage. If white pattern appears inside the battery or paste has accumulated at the bottom, replace the battery.
- If the compactor will not be in operation for a long period of time, store in cool dry place and check the battery charge level every month to maintain the performance of the battery.

- Check the battery regularly and make sure that each electrolyte level is to the bottom of the vent well (Figure 35). If necessary add only distilled water in a well-ventilated area.

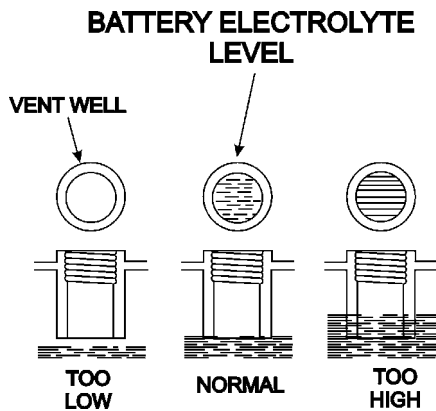



Figure 35. Battery Electrolyte Levels

BATTERY CHARGING

- DO NOT** charge battery with the battery cables connected to the compactor. The diodes will be damage by the high voltage.
- Batteries generate hydrogen gas which can be highly explosive. **DO NOT** smoke or allow flames or sparks near the battery, especially during charging of the battery. 
- Charge the battery in a open air environment (plenty of ventilation).
- Before charging , remove the cap from each cell of the battery.
- Connect the positive (+) lead of the charger to the positive (+) terminal of the battery and the negative (-) lead of the charger to the negative (-) terminal of the battery. **DO NOT** reverse the polarity when charging. Reverse polarity will damage the charger rectifier or the battery.
- Battery fluid will be lost through continuous charging and discharging.
- Discontinue charging if the electrolyte temperature exceeds 117° F (45° C).

NOTICE

During summer much more battery fluid is lost than in winter. Before starting, check battery electrolyte levels and replenish with distilled water to the upper mark on the battery.

BATTERY CABLE CONNECTION (Option)

- Take off the battery cover by removing the M6 nuts that secure the battery holder to the cover.
- When removing battery cables, disconnect the ground side (normally negative) first (Figure 36).
- When installing battery cable connect the ground side (normally negative) last.

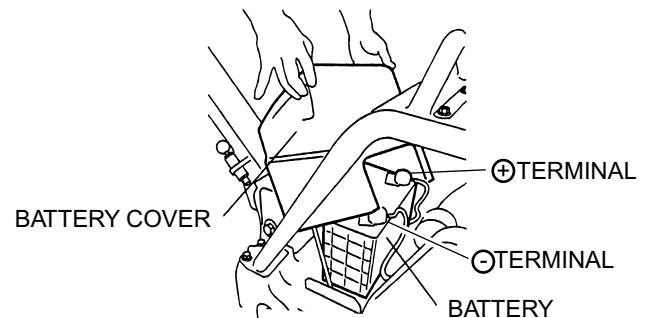

Figure 36. Removing Battery Cover

CHECKING FUEL FILTER

1. Clean the fuel filter (Figure 37) every 3 months or 200 hours.
2. Replace fuel filter every 6 months or 400 hours.
3. To clean the fuel filter, loosen the nuts of the fuel cock and pull out the filter from the F.O. tank filler port. Wash the filter thoroughly with diesel fuel oil.
4. Remove fuel supply lines (items 1 and 2) from fuel filter (Figure 39) and install new filter.

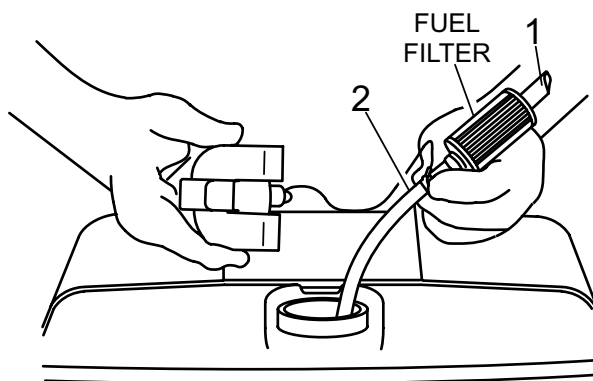

Figure 37. Fuel Filter

LONG TERM STORAGE

When storing your compactor for long periods do the following:

1. Run the engine at idle speed for 3-5 minutes.
2. Stop the engine. Drain the engine crankcase oil while the engine is still warm. Fill engine crankcase with fresh oil.
3. Wipe any oil or dirt that may have accumulated on the compactor.
4. The new engine can normally be stored dry for up to one year.
5. In very humid climates or coastal regions, the protective treatment is sufficient for up to 6 months.
6. Store compactor in a cool dry place out of the reach of children or unauthorized personnel

Troubleshooting

For further maintenance please reference compactor and engine troubleshooting tables on proceeding pages.

TROUBLE SHOOTING (COMPACTOR)

Troubleshooting (Compactor)		
Symptom	Possible Problem	Solution
Travel speed low and vibration weak.	Clutch slips?	Adjust or replace clutch.
	V-belt slips?	Adjust or replace V-belt.
	Excessive oil in vibrator?	Fill to correct level.
	Trouble in vibrator internals?	Check vibrator assembly for any worn or defective parts, replace any defective parts.
	Aeration in hydraulic oil for for travel reversing system?	Purge air in hydraulic oil. (Bleed plug)
	Engine speed incorrect?	Set engine speed to correct RPM.
Travels forward or backward but unable to switch direction.	Travel reversing system inoperative?	Check entire travel system.
	Reversing lever installation correct?	Clean installation of reversing lever.
	Broken or defective oil hose?	Replace oil hose.
	Aeration in hydraulic oil for for travel reversing system?	Purge air in hydraulic oil. (Bleed plug)
	Excessive oil in reversing system?	Fill to correct level.
	Selector valve clogged with trash?	Clean selector valve.
	Cylinder piston bearing failure?	Check piston bearing in cylinder for leakage at USH packing.
Does not travel in forward or reverse	V-belt disengaged or slips?	Engage V-belt, adjust or replace.
	Clutch slips?	Adjust clutch, replace if necessary.
	Pump input shatkey or adapter key-way damaged?	Replace input shatkey or adapter key-way
	Cylinder piston bearing failure?	Check piston bearing in cylinder for leakage at USH packing.
Reversing lever operating resistance great.	Excessive hydraulic oil?	Fill to correct level.

TROUBLE SHOOTING (ENGINE)

Troubleshooting (Engine)		
Symptom	Possible Problem	Solution
Engine will not start or start is delayed, although engine can be turned over.	No Fuel reaching injection pump?	Add fuel. Check entire fuel system.
	Defective fuel pump?	Replace fuel pump.
	Fuel filter clogged?	Replace fuel filter and clean tank.
	Faulty fuel supply line?	Replace or repair fuel line.
	Compression too low?	Check piston, cylinder and valves. Adjust or repair per engine repair manual.
	Fuel pump not working correctly?	Repair or replace fuel pump.
	Oil pressure too low?	Check engine oil pressure.
	Low starting temperature limit exceeded?	Comply with cold starting instructions and proper oil viscosity.
	Defective battery?	Charge or replace battery.
	Air or water mixed in fuel system?	Check carefully for loosened fuel line coupling, loose cap nut, etc.
At low temperatures engine will not start.	Engine oil too thick?	Refill engine crankcase with correct type of oil for winter environment.
	Defective battery?	Replace battery.
Engine fires but stops soon as starter is switched off.	Fuel filter blocked?	Replace fuel filter.
	Fuel supply blocked?	Check the entire fuel system.
	Defective fuel pump?	Replace fuel pump.
Engine stops by itself during normal operation.	Fuel tank empty?	Add fuel.
	Fuel filter blocked?	Replace fuel filter.
	Defective fuel pump?	Replace fuel pump.
	Mechanical oil pressure shutdown sensor stops the engine due to low oil?	Add oil. Replace low oil shutdown sensor if necessary.
Low engine power, output and speed.	Fuel tank empty?	Replace fuel filter.
	Fuel filter clogged?	Replace fuel filter.
	Fuel tank venting is inadequate?	Ensure that tank is adequately vented.
	Leaks at pipe unions?	Check threaded pipe unions tape and tighten unions as required.
	Speed control lever does not remain in selected position?	See engine manual for corrective action.
	Engine oil level too full?	Correct engine oil level.
	Injection pump wear?	Use No. 2-D diesel fuel only. Check the fuel injection pump element and delivery valve assembly and replace as necessary.

TROUBLE SHOOTING (ENGINE)

Troubleshooting (Engine) - continued		
Symptom	Possible Problem	Solution
Low engine power output and low speed, black exhaust smoke.	Air filter blocked?	Clean or replace air filter.
	Incorrect valve clearances?	Adjust valves per engine specification.
	Malfunction at injector?	See engine manual.
Engine overheats.	Too much oil in engine crankcase?	Drain off engine oil down to uppermark on dipstick.
	Entire cooling air system contaminated/ blocked?	Clean cooling air system and cooling fin areas.
	Fan belt broken or elongated?	Change belt or adjust belt tension.
	Coolant insufficient?	Replenish coolant.
	Radiator net or radiator fin clogged with dust?	Clean net or fin carefully.
	Fan, radiator, or radiator cap defective?	Replace defective part.
	Thermostat defective?	Check thermostat and replace if necessary.
Head gasket defective or water leakage?	Replace parts.	

EXPLANATION OF CODE IN REMARKS COLUMN

The following section explains the different symbols and remarks used in the Parts section of this manual. Use the help numbers found on the back page of the manual if there are any questions.

NOTICE

The contents and part numbers listed in the parts section are subject to change **without notice**. Multiquip does not guarantee the availability of the parts listed.

SAMPLE PARTS LIST

NO.	PART NO.	PART NAME	QTY.	REMARKS
1	12345	BOLT	1	INCLUDES ITEMS W/%
2%		WASHER, 1/4 IN.		NOT SOLD SEPARATELY
2%	12347	WASHER, 3/8 IN. ..	1	MQ-45T ONLY
3	12348	HOSE	A/R	MAKE LOCALLY
4	12349	BEARING	1	S/N 2345B AND ABOVE

NO. Column

Unique Symbols — All items with same unique symbol (@, #, +, %, or >) in the number column belong to the same assembly or kit, which is indicated by a note in the “Remarks” column.

Duplicate Item Numbers — Duplicate numbers indicate multiple part numbers, which are in effect for the same general item, such as different size saw blade guards in use or a part that has been updated on newer versions of the same machine.

NOTICE

When ordering a part that has more than one item number listed, check the remarks column for help in determining the proper part to order.

PART NO. Column

Numbers Used — Part numbers can be indicated by a number, a blank entry, or TBD.

TBD (To Be Determined) is generally used to show a part that has not been assigned a formal part number at the time of publication.

A blank entry generally indicates that the item is not sold separately or is not sold by Multiquip. Other entries will be clarified in the “Remarks” Column.

QTY. Column

Numbers Used — Item quantity can be indicated by a number, a blank entry, or A/R.

A/R (As Required) is generally used for hoses or other parts that are sold in bulk and cut to length.

A blank entry generally indicates that the item is not sold separately. Other entries will be clarified in the “Remarks” Column.

REMARKS Column

Some of the most common notes found in the “Remarks” Column are listed below. Other additional notes needed to describe the item can also be shown.

Assembly/Kit — All items on the parts list with the same unique symbol will be included when this item is purchased.

Indicated by:

“INCLUDES ITEMS W/(unique symbol)”

Serial Number Break — Used to list an effective serial number range where a particular part is used.

Indicated by:

“S/N XXXXX AND BELOW”

“S/N XXXX AND ABOVE”

“S/N XXXX TO S/N XXX”

Specific Model Number Use — Indicates that the part is used only with the specific model number or model number variant listed. It can also be used to show a part is NOT used on a specific model or model number variant.

Indicated by:

“XXXXX ONLY”

“NOT USED ON XXXX”

“Make/Obtain Locally” — Indicates that the part can be purchased at any hardware shop or made out of available items. Examples include battery cables, shims, and certain washers and nuts.

“Not Sold Separately” — Indicates that an item cannot be purchased as a separate item and is either part of an assembly/kit that can be purchased, or is not available for sale through Multiquip.

SUGGESTED SPARE PARTS

MVH406DSZ/DSCPAS W/ROBIN D1B40T92040 DIESEL ENGINE

1 to 3 Units

Qty.	P/N	Description
1.....	956100060.....	THROTTLE WIRE
2.....	070200373.....	V-BELT
3.....	DH50484100	AIR FILTER ELEMENT
1.....	DH05088901	STARTER ROPE
2.....	DH01635210	FUEL FILTER
1.....	DH01535302	CAP, FUEL TANK
1.....	DH01542703	OIL SUCTION FILTER
1.....	DH50384401	IGNITION SWITCH W/ KEY
3.....	DH50404900	KEY, IGNITION SWITCH
3.....	939010260.....	SHOCK ABSORBER

NOTICE

Part numbers on this Suggested Spare Parts list may supersede/replace the part numbers shown in the following parts lists.

NAMEPLATES AND DECALS

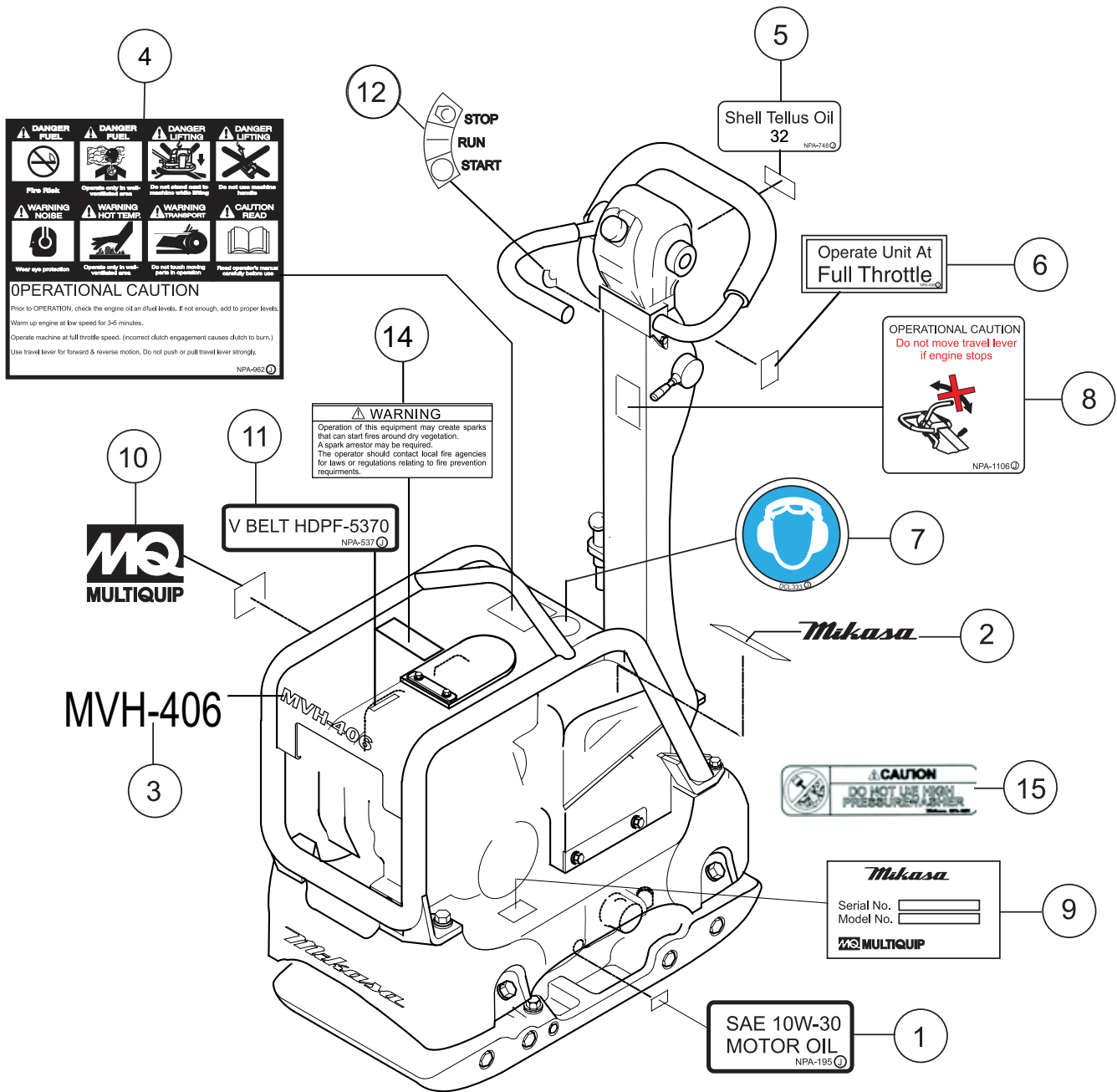

NAMEPLATES AND DECALS

<u>NO.</u>	<u>PART NO.</u>	<u>PART NAME</u>	<u>QTY.</u>	<u>REMARKS</u>
1	920201950	DECAL: OIL SAE 10W-30	1	
2	920105070	DECAL: MIKASA LOGO	1	ELECT. START MODEL ONLY
3	920211640	DECAL: MODEL LOGO MVH-406	1	
4	920209620	DECAL: CAUTION	1	
5	920211090	DECAL: SHELL TELLUS OIL 32	1	
6	920204580	DECAL: FULL THROTTLE	1	
7	920203330	DECAL: EAR PROTECTION	1	
8	920211060	DECAL: CAUTION (TRAVEL LEVER)	1	
9	920213920	DECAL: SERIAL NO.	1	CONTACT MQ PARTS DEPT.
9	920216620	DECAL: SERIAL NO. (PAS)	1	CONTACT MQ PARTS DEPT.
10	920201580	DECAL: MQ LOGO	1	
11	920211010	DECAL: V-BELT HDPF-5370	1	
12	920106760	DECAL: STOP-RUN-START	1	
14	920214100	DECAL: E/G FIRE WARNING	1	
15	920216610	DECAL: CAUTION (FOR WASHING)	1	

VIBRATING PLATE ASSY.

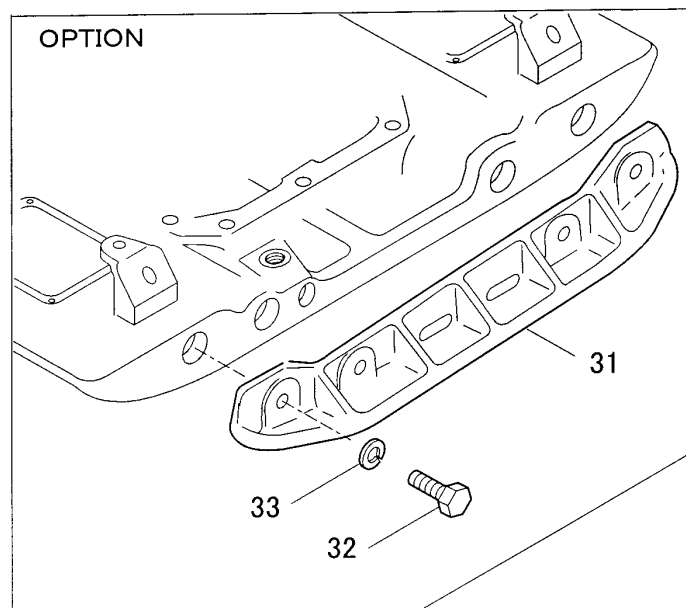
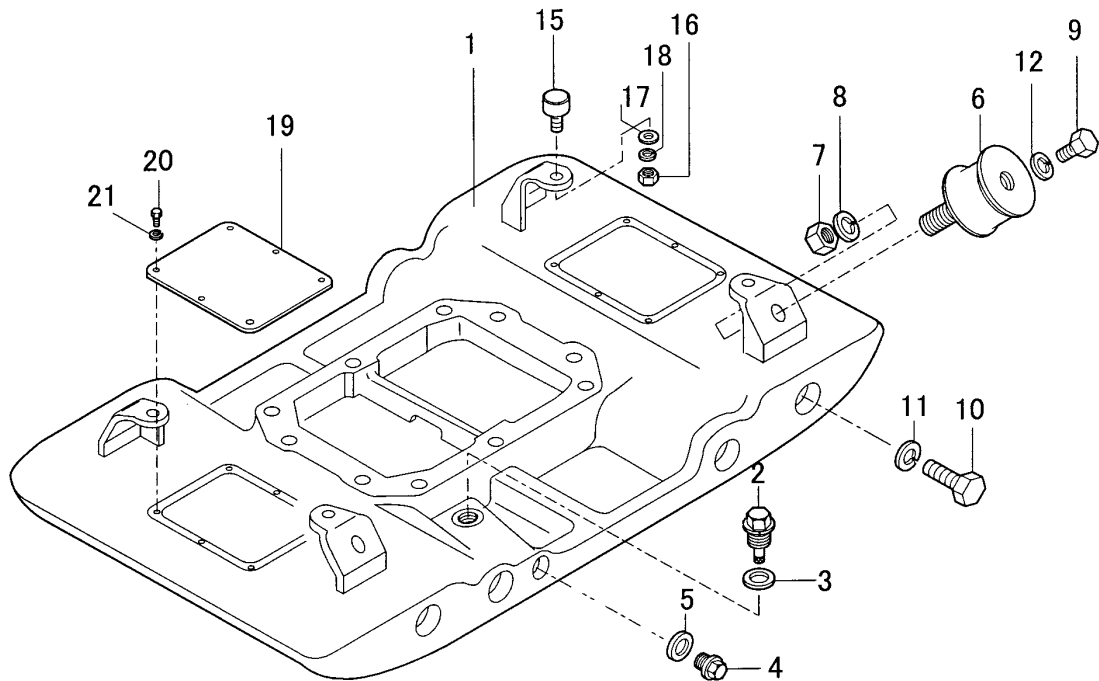

VIBRATING PLATE ASSY.

<u>NO.</u>	<u>PART NO.</u>	<u>PART NAME</u>	<u>QTY.</u>	<u>REMARKS</u>
1	465118410	VIBRATING PLATE	1	
2	464458940	OIL GAUGE	1	
3	953402930	COPPER PACKING 19X30X1	1	
4	953400270	PLUG 1/4X14 10L	1	
5	953405260	PACKING 1/4 (CU)	1	
6	939010260	SHOCK ABSORBER 110X60H	4	
7	020316130	NUT M16	4	
8	030216400	WASHER, LOCK M16	4	
9	001221635	BOLT 16X35 T	4	
10	001221830	BOLT 18X30 T	8	
11	030218460	WASHER, LOCK M18	8	
12	030216400	WASHER, LOCK M16	4	
15	939010010	SHOCK ABSORBER, STOPPER 45	4	
16	020310080	NUT M10	4	
17	031110160	WASHER, FLAT M10	4	
18	030210250	WASHER, LOCK M10	4	
19	465345050	COVER, VIBRATING PLATE	2	
20	001220815	BOLT 8X15 T	12	
21	030208200	WASHER, LOCK M8	12	
31	456210690	EXTENSION PLATE	2.....	OPTION
32	001221850	BOLT 18X50 T.....	8.....	OPTION
33	030218460	WASHER, LOCK M18.....	8.....	OPTION

BASE AND ENGINE ASSY.

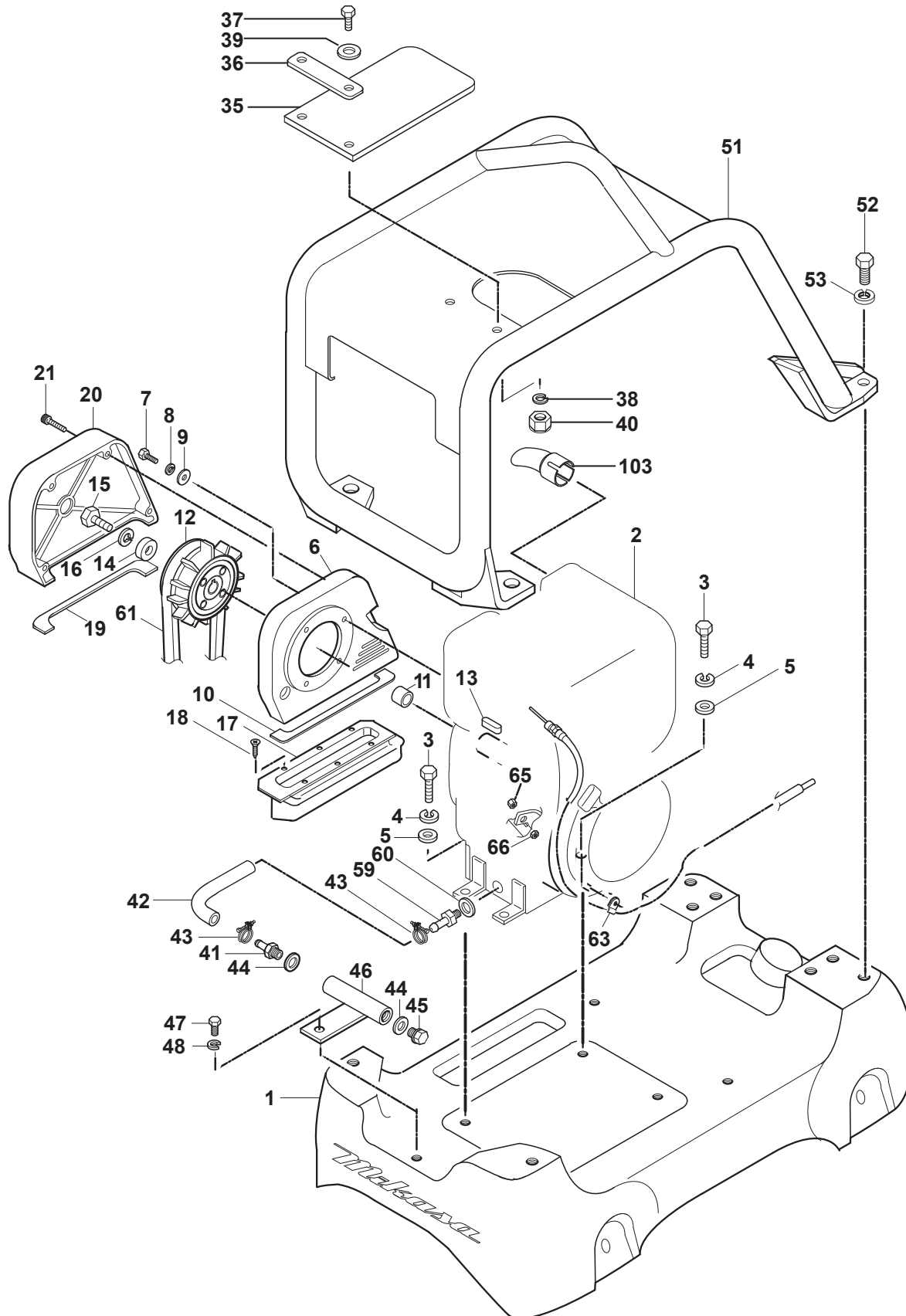

BASE AND ENGINE ASSY.

<u>NO.</u>	<u>PART NO.</u>	<u>PART NAME</u>	<u>QTY.</u>	<u>REMARKS</u>
1	465118600	BASE	1	
2	918400800	ENGINE ASSY., 1B40	1	
3	001221030	BOLT 10X30T	4	
4	030210250	WASHER, LOCK M10	4	
5	031110160	WASHER, FLAT M10	4	
6	465217230	BELT COVER (IN) L100	1	
7	001221030	BOLT 10X30 T	4	
8	030210250	WASHER LOCK M8	4	
9	031108160	WASHER, FLAT M8	4	
10	465345100	DUST- PROOF SPONGE (IN)	1	
11	464457360	SPACER	1	
12	456343340	CLUTCH ASSY/CHM03/W. FAN	1	
13	951400110	KEY 7X7X35	1	
14	952403450	WASHER 11X35X4.5	1	
15	001221030	BOLT 10X30 T	1	
16	030210250	WASHER, LOCK M10	1	
17	465216990	DUST-PROOF COVER	1	
18	092006010	FLAT HEAD SCREW 6X10	6	
19	465345110	DUST-PROOF SPONGE (OUT)	1	
20	465217000	BELT COVER (OUT)	1	
21	001521045	SOCKET HEAD BOLT 10X45 T	4	
35	458450830	RUBBER COVER (GUARD FRAME)	1	
36	458450810	PLATE, COVER	1	
37	001220830	BOLT 8X30 T	1	
38	030208200	WASHER, LOCK M8	3	
39	031108160	WASHER, FLAT M8	3	
40	022710809	NYLON NUT M8	3	
41	2556390111	UNION	1	
42	2556380103	DRAIN HOSE	1	
43	0091720000	HOSE CLAMP	2	
44	0211140020	GASKET	2	
45	0401140030	PLUG	1	
46	464457380	DRAIN JOINT	1	
47	001220820	BOLT 8X20 T	1	
48	030208200	WASHER, LOCK M8	1	
49	454010020	CLAMP TC-100	1	
51	465118670	GUARD HOOK	1	
52	001221445	BOLT 14X45 T	4	
53	030214350	WASHER, LOCK M14	4	
59	465459670	UNION, OIL DRAIN	1	
60	50001600	JOINT A 22X27	1	
61	070200373	V-BELT	1	
63	2067550101	CLAMP COMPLETE	1	
65	020406040	NUT M6, H=4.2	1	
66	959406800	NUT M6 (SPECIAL-L10)	1	
103	465459660	EXHAUST PIPE	1	

VIBRATOR ASSY.

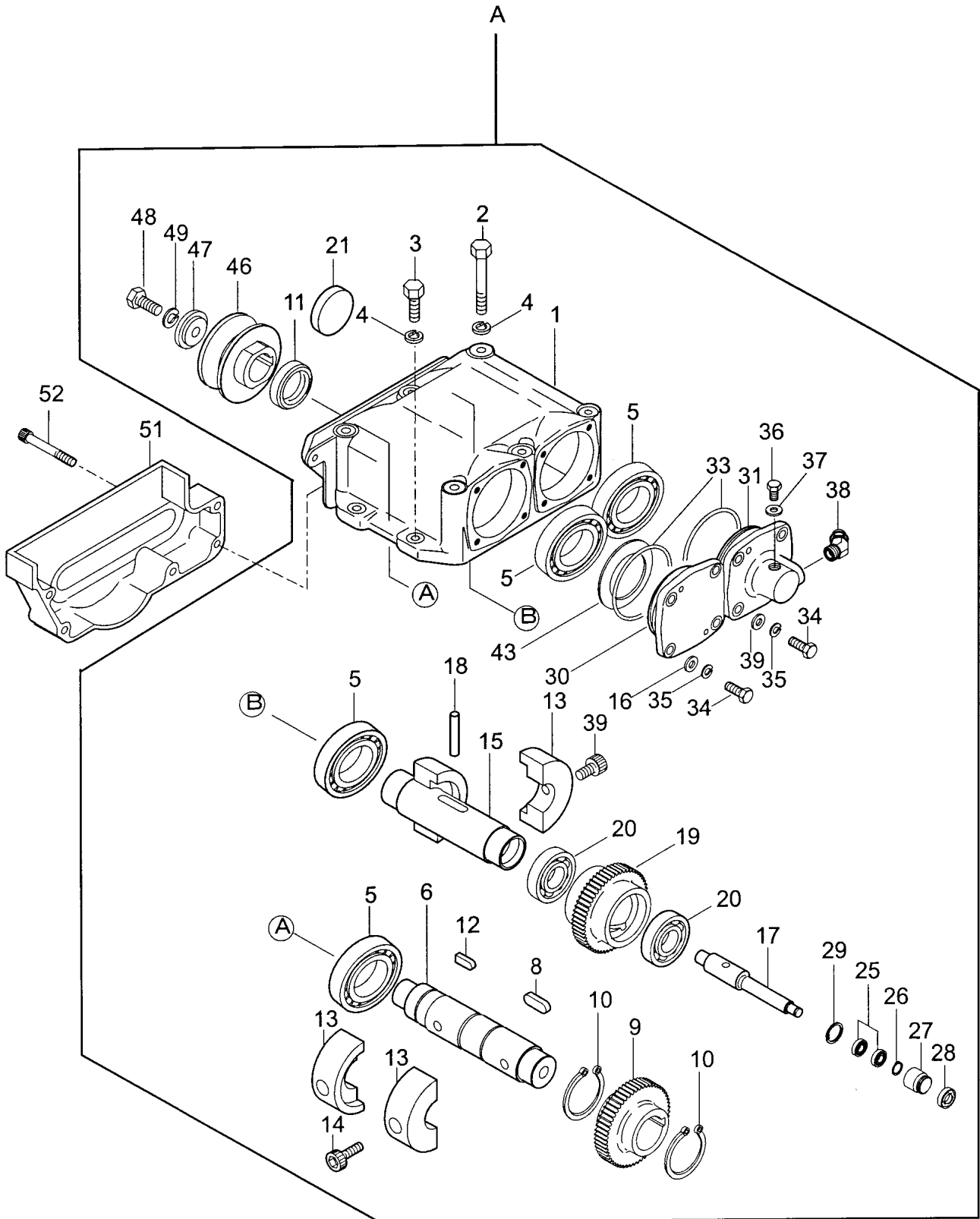

VIBRATOR ASSY.

<u>NO.</u>	<u>PART NO.</u>	<u>PART NAME</u>	<u>QTY.</u>	<u>REMARKS</u>
A	465910010	VIBRATOR ASSY.....	1.....	INCLUDES ITEMS W/#
1#	464117880	VIBRATING CASE	1	
2#	001221470	BOLT14X150 T	6	
3#	001221450	BOLT 14X50 T	4	
4#	030214350	WASHER, LOCK M14	10	
5#	047920120	ROLLER BEARING NJ310EMC4	4	
6#	457212410	ROTARY SHAFT, DRIVE	1	
8#	951405370	KEY 15X10X39 RR	1	
9#	456327150	GEAR, DRIVE	1	
10#	080200550	STOP RING S-55	2	
11#	060105030	OIL SEAL SB-50729	1	
12#	951404970	KEY 12X8X30 R	1	
13#	465345080	ECCENTRIC ROTATOR	4	
14#	009120301	SOCKET HEAD BOLT 16X30 T	2	
15#	456337670	ROTARY SHAFT, DRIVEN/304B	1	
16#	009120302	SOCKET HEAD BOLT 16X30T	2	
17#	456337380	PISTON ROD	1	
18#	456010010	KNOCK PIN 10X70	1	
19#	464343720	GEAR (DRIVEN)	1	
20#	040006911	BEARING 6911	2	
21#	953010030	SEAL CAP/SC72-8N	1	
25#	042506000	BEARING 6000ZZSG	2	
26#	080200100	STOP RING S-10	1	
27#	455435051	PISTON, 22.4D	1	
28#	455010070	PACKING USH-22. 4X30X5	1	
29#	080100260	STOP RING R-26	1	
30#	456327130	BEARING COVER	1	
31#	456210636	CYLINDER (L)	1	
33#	050101050	O-RING G-105	2	
34#	001221025	BOLT 10X25 T	8	
35#	030210250	WASHER, LOCK M10	8	
36#	001220812	BOLT 8X12 T	1	
37#	953404600	COPPER PACKING 8X16X2	1	
38#	455010020	ELBOW 45 DEG. 15-0404	1	
39#	031110160	WASHER, FLAT M10	4	
43#	952405470	SHIM 90X110X0.5	2	
46#	465345090	PULLEY	1	
47#	456437920	WASHER, PULLEY	1	
48#	001221230	BOLT 12X30 T	1	
49#	030212300	WASHER, LOCK M12	1	
51	465217010	BELT COVER (LOWER)	1	
52	001520856	SOCKET HEAD BOLT 8X80 T	5	

CONTROL HANDLE ASSY.

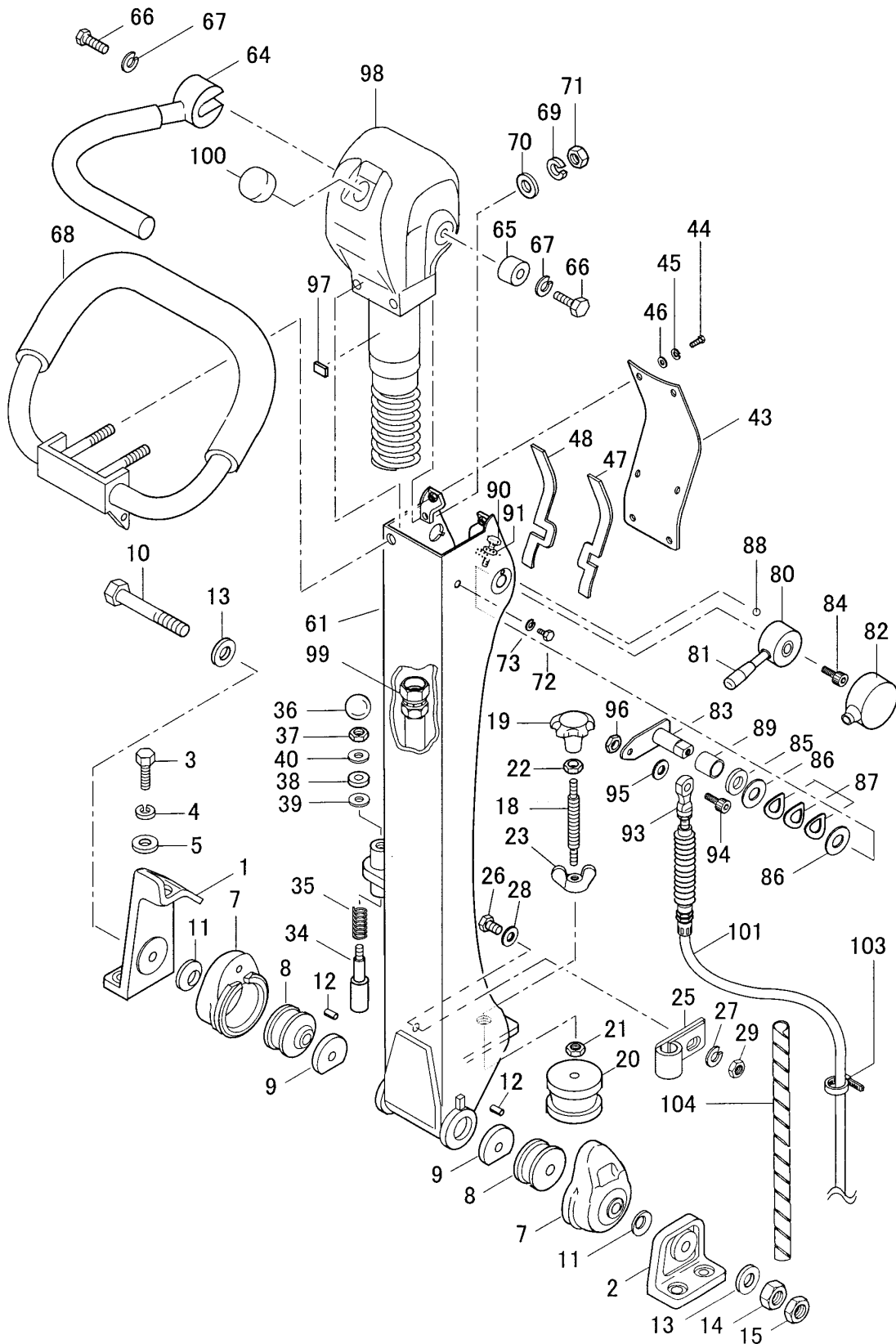

CONTROL HANDLE ASSY.

<u>NO.</u>	<u>PART NO.</u>	<u>PART NAME</u>	<u>QTY.</u>	<u>REMARKS</u>
1	464343680	HANDLE BRACKET	1	
2	456336420	HANDLE BRACKET(R)	1	
3	001221235	BOLT 12X35 T	4	
4	030212300	WASHER, LOCK M12	4	
5	031112230	WASHER, FLAT M12	4	
7	456336400	RUBBER COUPLING	2	
8	456449940	SHOCK ABSORBER	2	
9	456449930	RUBBER PLATE	2	
10	001221681	BOLT 16X250 T	1	
11	032124400	CONICAL SPRING WASHER M24	2	
12	025406016	SPRING PIN 6X16	2	
13	031116260	WASHER, FLAT M16	2	
14	020316130	NUT M16	1	
15	020416100	NUT M16, H=10	1	
18	455434950	SPINDLE	1	
19	455010030	KNOB	1	
20	939010060	SHOCK ABSORBER 60	1	
21	020410060	NUT M10, H=6	1	
22	020412070	NUT M12, H=7	1	
23	022411635	WING NUT M16	1	
25	954404230	CLAMP SA120-18	1	
26	001220620	BOLT 6X20 T	1	
27	030206150	WASHER, LOCK M6	1	
28	031106100	WASHER, FLAT M6	1	
29	020306050	NUT M6	1	
34	501402870	HANDLE STOPPER	1	
35	501402880	SPRING/HANDLE (1.4X18X44)	1	
36	959403460	BALL GRIP 32D-M10	1	
37	020410060	NUT M10, H=6	1	
38	456449980	RUBBER PACKING 9D-20D-5T	1	
39	953405260	PACKING 1/4 (CU)	1	
40	031110160	PW M10	1	
43	465345520	HANDLE COVER	1	
44	001220615	BOLT 6X15 T	6	
45	030206150	WASHER, LOCK M6	6	
46	031106100	WASHER, FLAT M6	6	
47	464457710	PACKING A, HANDLE COVER	1	
48	464457720	PACKING B, HANDLE COVER	1	
61	465118650	COLUMN, HANDLE	1	
64	464216630	TRAVEL LEVER	1	
65	464457400	HANDLE BOSS	1	
66	001221030	BOLT 10X30 T	2	
67	030210250	WASHER, LOCK M10	2	
68	464216620	HANDLE W/RUBBER GRIP	1	

CONTROL HANDLE ASSY. (CONTINUED)

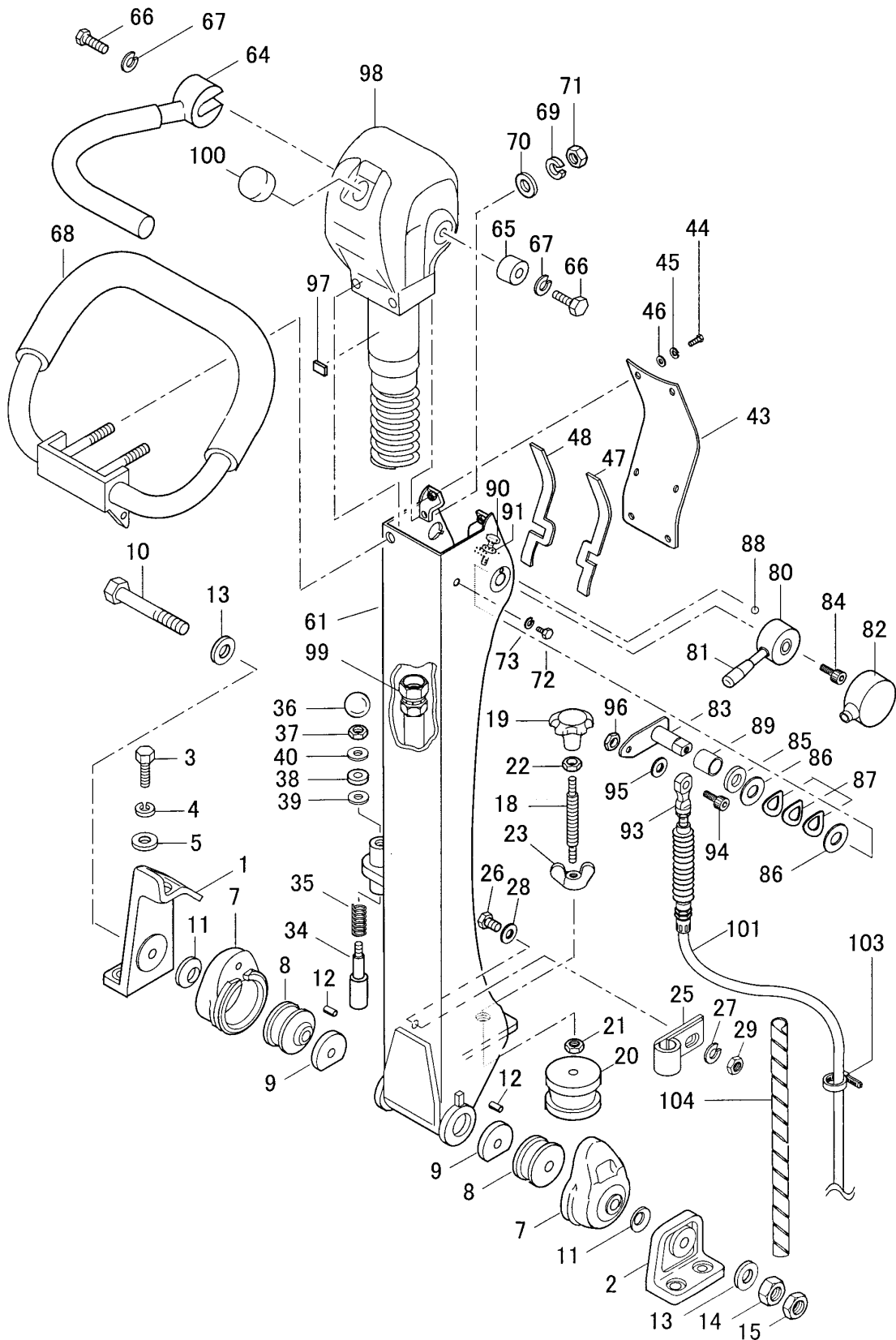

CONTROL HANDLE ASSY. (CONTINUED)

NO.	PART NO.	PART NAME	QTY.	REMARKS
69	030210250	WASHER, LOCK M10	2	
70	031110160	WASHER, FLAT M10	2	
71	020310080	NUT M10	2	
72	001220825	BOLT 8X25 T	2	
73	030208200	WASHER, LOCK M8	2	
80	464457340	THROTTLE LEVER	1	
81	959403840	BAR GRIP, I.D. 12MM	1	
82	464457420	COVER, THROTTLE LEVER	1	
83	464457350	ARM, THROTTLE	1	
84	001520820	SOCKET HEAD BOLT 8X20 T	1	
85	031116260	WASHER, FLAT M16	1	
86	458450660	WASHER 16.4-35-0.6	2	
87	033910080	CONICAL SW 16,3X31.5X1.2	3	
88	464457440	STEEL BALL D6 (SUJ)	1	
89	464010010	DRY BUSHING /LFB-1620	1	
90	001220625	BOLT 6X25 T	2	
91	020306050	NUT M6	2	
93	464010020	ROD END M5	1	
94	001520520	SOCKET HEAD BOLT 5X20 T	1	
95	031105080	WASHER, FLAT M5	1	
96	020305040	NUT M5	1	
97	464457930	RUBBER PIECE (T2)	1	
99	954002270	OIL HOSE W/SPRING 1/4X920	1	
101	956100060	THROTTLE WIRE	1	
103	454010020	CLAMP TC-100	1	
104	959021810	SPIRAL TUBE KEP6/L=500	1	

HAND PUMP ASSY.

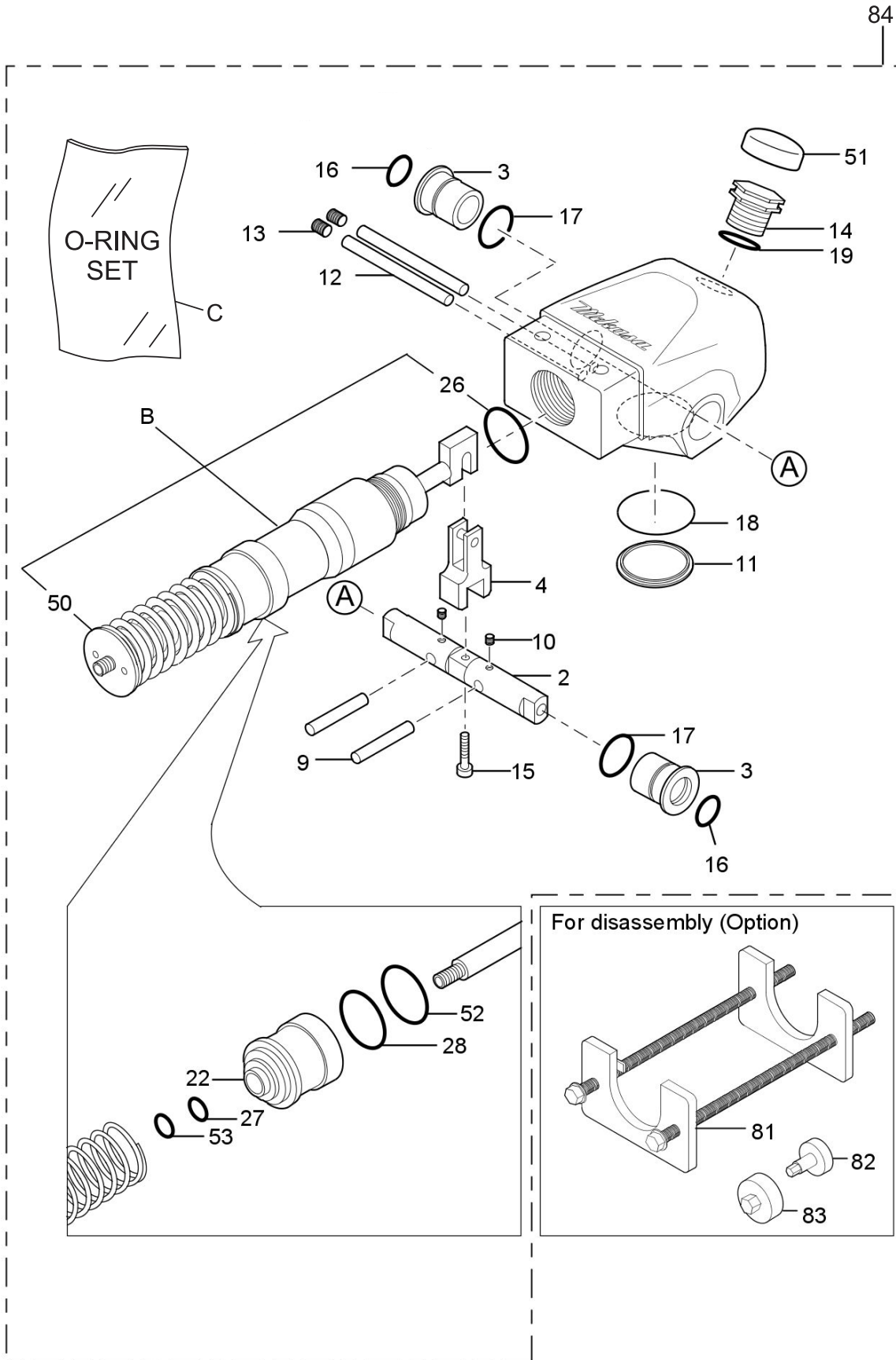

HAND PUMP ASSY.

NO.	PART NO.	PART NAME	QTY.	REMARKS
B%	464910070	ACCUMULATOR	1	
C%	464910080	O-RING DUST, SEAL, SET	1	INCLUDES ITEMS W/#
2%	464010040	CONTROL SHAFT	1	
3%	464010050	BUSH	2	
4%	464010060	CAM	1	
9%	464010070	STOPPER	2	
10%	099205005	SOCKET HEAD SCREW 5X5 T	2	
11%	464010080	PLUG	1	
12%	464010090	PIN,STOPPER	2	
13%	464010100	PLUG	2	
14%	458010080	BREATHER	1	
15%	014206020	SOCKET HEAD BOLT 6X20 T	1	REPLACES P/N 001520620
16#%	050200200	O-RING P-20	2	
17#%	050210220	O-RING P-22	2	REPLACES P/N 050200220
18#%	050300380	O-RING S-38	1	
19#	050200180	O-RING P-18	1	
22%	464010111	ACCUMULATOR CASE	1	
26#%	050300400	O-RING S-40	1	
27#%	050200150	O-RING P-15	1	
28#%	050100400	O-RING G-40	1	
50%	464010120	SPRING PLUG	1	
51%	458451630	BREATHER CAP	1	
52#%	069904010	DUST SEAL SER-40	1	
53#%	069901010	DUST SEAL SER-15	1	
81%	984010060	SPRING COMPRESSION TOOL	1	
82%	984010040	DISASSEMBLING TOOL A	1	
83%	984010050	DISASSEMBLING TOOL B	1	
84	465217100	HAND PUMP ASSY.	1	INCLUDES ITEMS W/%

BATTERY ASSY.

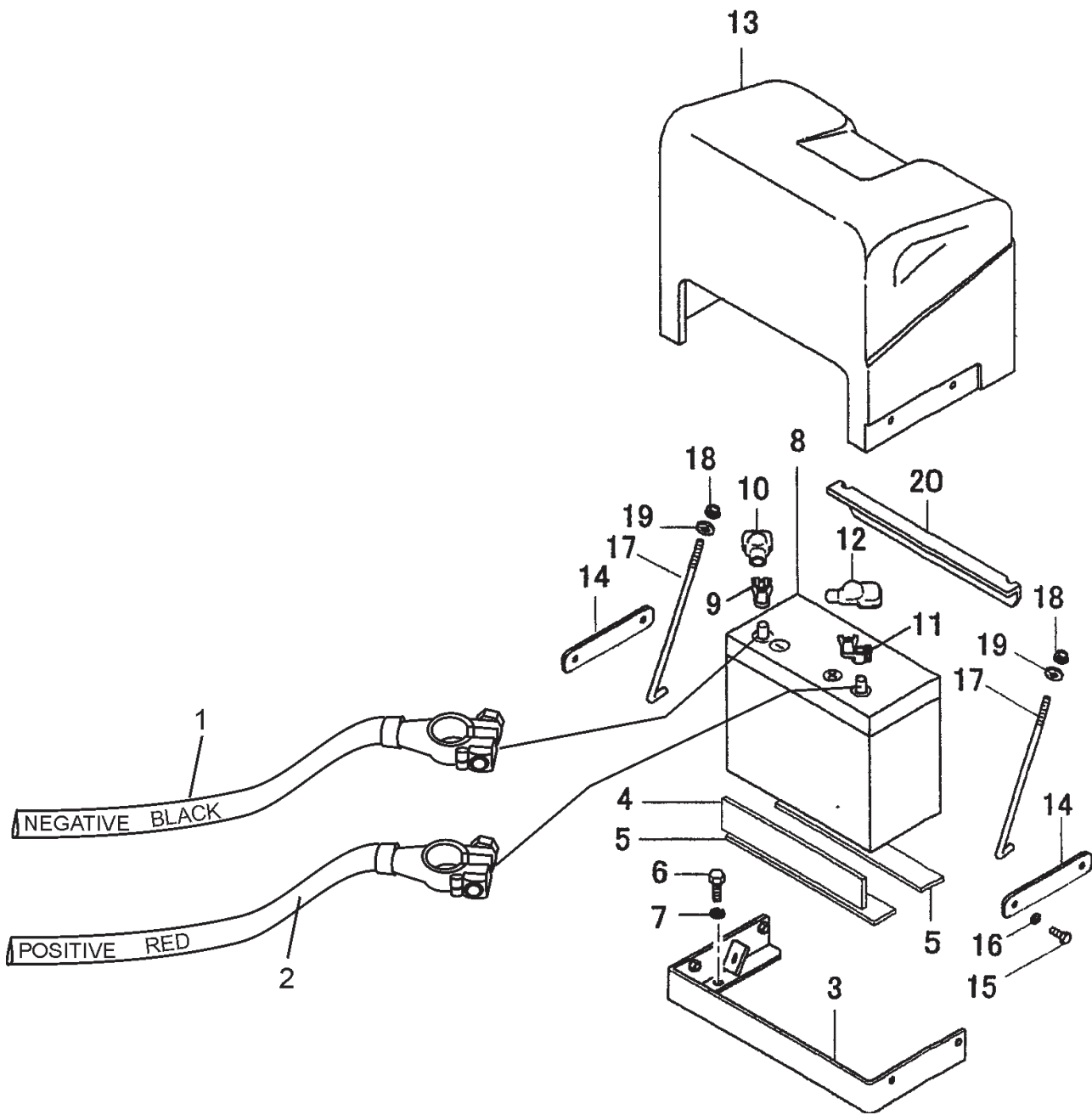

BATTERY ASSY.

<u>NO.</u>	<u>PART NO.</u>	<u>PART NAME</u>	<u>QTY.</u>	<u>REMARKS</u>
1	464457460	BATTERY CORD (-) 400L	1	
2	464457470	BATTERY CORD (+) 550L	1	
3	464216660	CRADLE, BATTERY	1	
4	456447590	RUBBER PLATE (E) 28X240X5	1	
5	456447600	RUBBER PLATE 50X240X10	2	
6	012210020	SOCKET HEAD BOLT 10X20 T	2	REPLACES P/N 001221020
7	030210250	WASHER, LOCK M10	2	
8	955010020	BATTERY 46B24L	1	
9	955404130	BATTERY TERMINAL (-)	1	
10	955300220	TERMINAL COVER (-)	1	
11	955404140	BATTERY TERMINAL (+)	1	
12	955300210	TERMINAL COVER (+)	1	
13	464021020	COVER, BATTERY	1	
14	464457410	FIXED PLATE, BATTERY COVER	2	
15	011208025	BOLT 8X25 T	4	REPLACES P/N 001220825
16	030208200	WASHER, LOCK M8	4	
17	464457390	BATTERY BOLT	2	
18	022710809	NYLON NUT M8	2	
19	0401450080	WASHER, FLAT M8	2	REPLACES P/N 031108160
20	464343740	HOLDER, BATTERY	1	

COMPACTION ANALYZING SYSTEM ASSY. (MVH406DSCPAS)

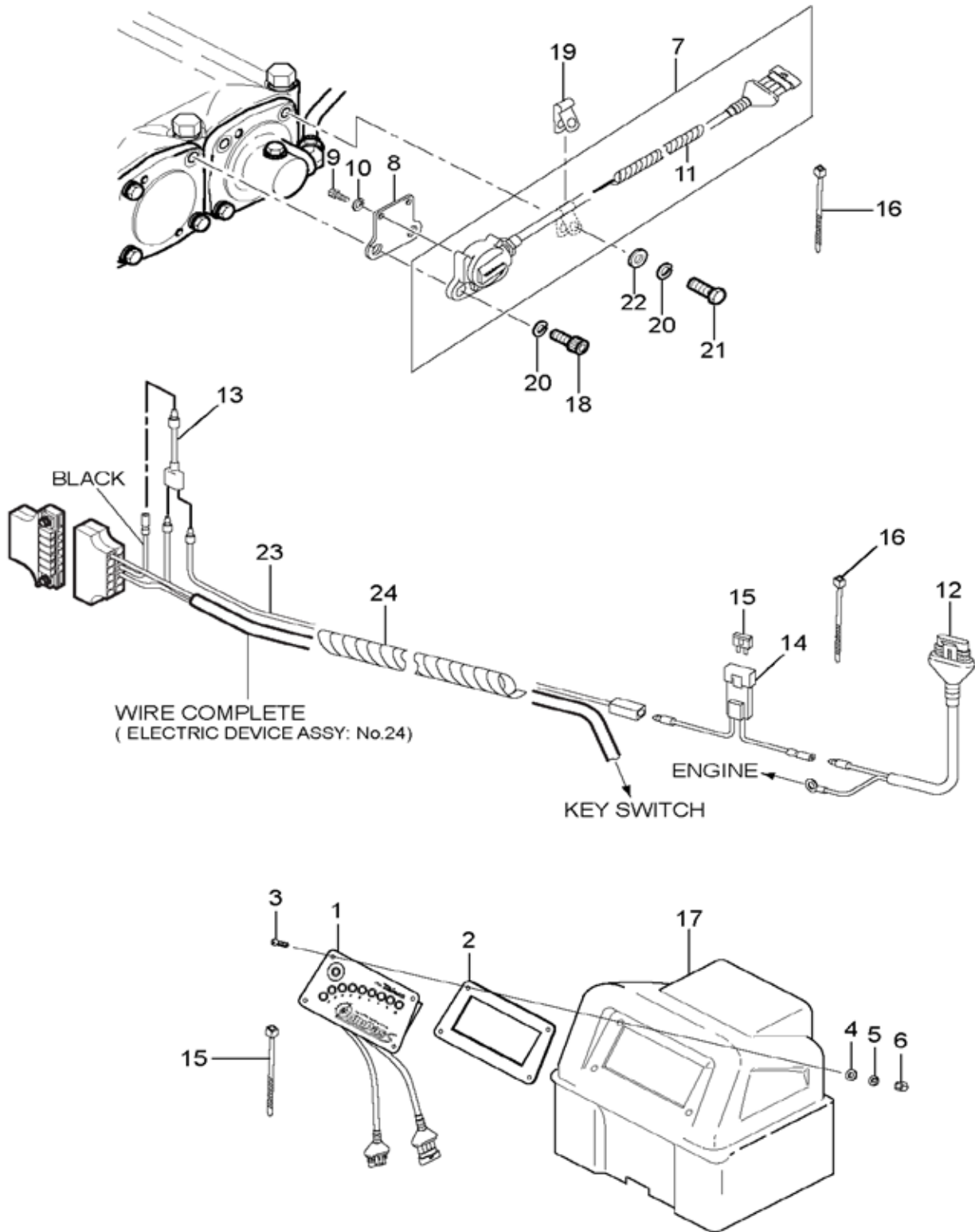

COMPACTION ANALYZING SYSTEM ASSY. (MVH4O6DSCPAS)

<u>NO.</u>	<u>PART NO.</u>	<u>PART NAME</u>	<u>QTY.</u>	<u>REMARKS</u>
1	465350490	COMPACTION SENSOR PANEL	1	
2	464350510	PACKING,SENSOR	1	
3	009110062	SOCKET HEAD SCREW 6X20	4	
4	952404470	WASHER, FLAT M6.....	4.....	REPLACES P/N 031106100
5	030206150	WASHER, LOCK M6	4	
6	022710607	NYLON NUT M6	4	
7	464350500	ACCELERATION SENSOR ASSY.....	1.....	INCLUDES ITEMS W/ #
8	464464350	SENSOR HOLDER COVER	1	
9	H5HB051000	SOCKET HEAD BOLT 5X10 T.....	2.....	REPLACES P/N 001520510
10	030205130	WASHER, LOCK M5	2	
11#	959021812	SPIRAL TUBE 6D-800L	1	
12	464350390	WIRE HARNESS, SENSOR	1	
13	515450380	WIRE HARNESS	1	
14	464464520	FUSE HOLDER, SENSOR.....	1.....	INCLUDES ITEMS W/ %
15%	464010140	FUSE 2 AMP	1	
16	506010070	CLAMP TC-150	7	
17	464022020	COVER,BATTERY	1	
18	001521030	SOCKET HEAD BOLT 10X30 T	2	
19	959408330	WIRE CLIP, SENSOR	1	
20	030210250	WASHER, LOCK M10	3	
21	0105091025	BOLT 10X25 T.....	1.....	REPLACES P/N 001221025
22	031110160	WASHER, FLAT M10	1	
23	955408440	WIRE HARNESS 500L	1	
24	030208200	SPIRAL TUBE 6D-800L	1	

ELECTRIC DEVICE ASSY.

CONNECTION LIST

	B	IG	ST
OFF			
1	●	●	
2	●	●	●

KEYSWITCH

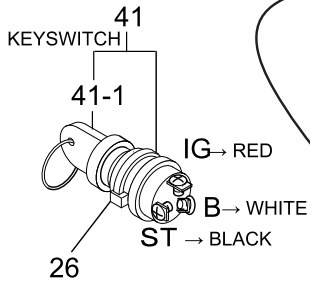

BUZZER

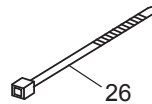
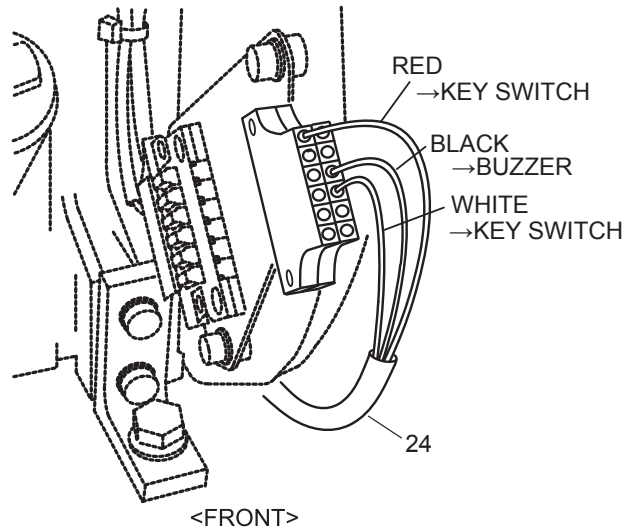
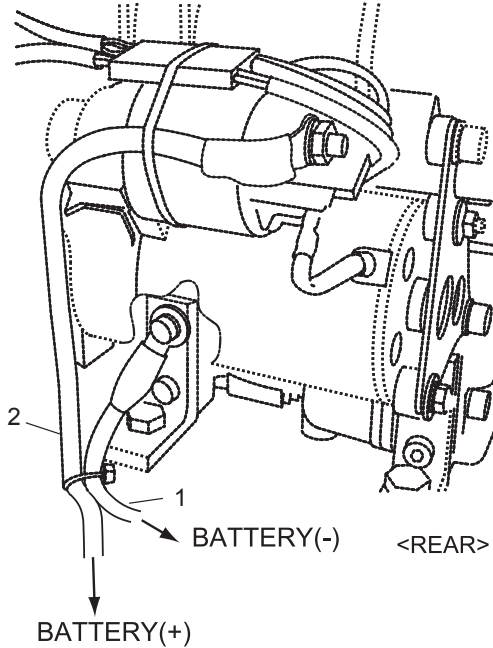
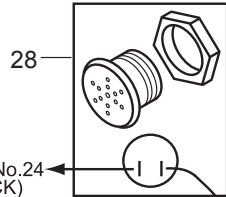

ELECTRIC DEVICE ASSY.

<u>NO.</u>	<u>PART NO.</u>	<u>PART NAME</u>	<u>QTY.</u>	<u>REMARKS</u>
1	464457460	BATTERY CORD (-) 400L	1	
2	464457470	BATTERY CORD (+) 550L	1	
24	465345590	WIRE COMPLETE	1	
26	454010020	CLAMP TC-100	3	
28	DH50465100	BUZZER (EBL)	1	
41	DH50384401	IGNITION SWITCH W/KEY ASSY.	1.....	INCLUDES ITEMS W/ #
41-1#	DH50404900	IGNITION KEY	1	

ROBIN D1B40T92040 — SPARE PARTS KIT ASSY.

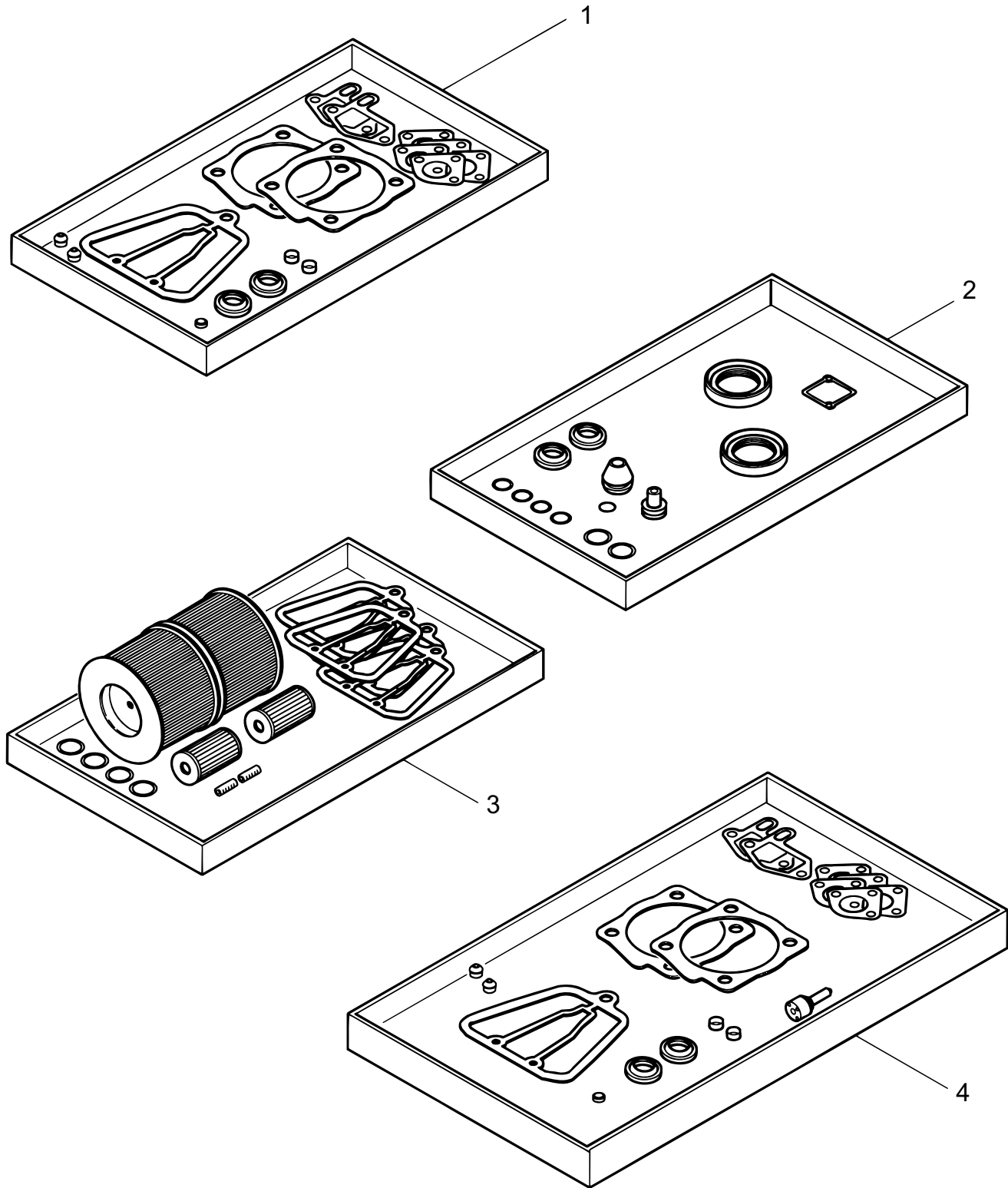

ROBIN D1B40T92040 — SPARE PARTS KIT ASSY.

<u>NO.</u>	<u>PART NO.</u>	<u>PART NAME</u>	<u>QTY.</u>	<u>REMARKS</u>
2	01679302	GASKET SET CRK.CASE	1	
3	01679400	1000H MAINTK.KIT	1	
4	01679510	EMERGENCY KIT	1	

ROBIN D1B40T92040 — ACCESSORIES ASSY.

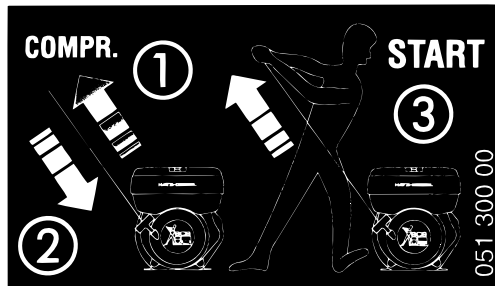
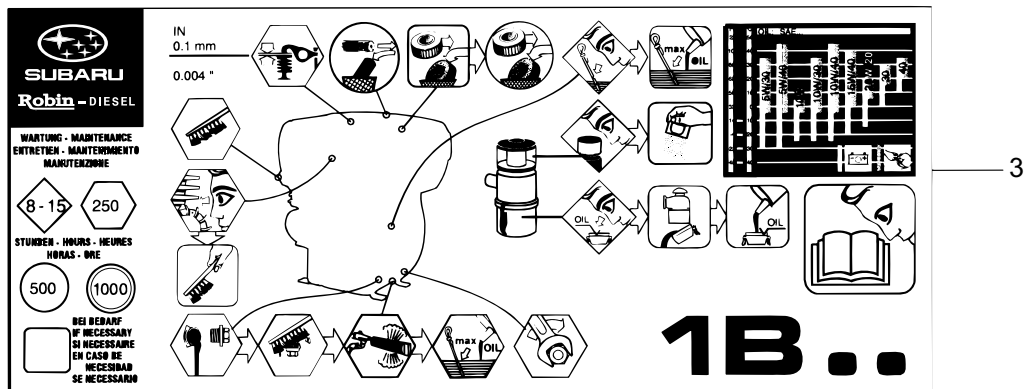
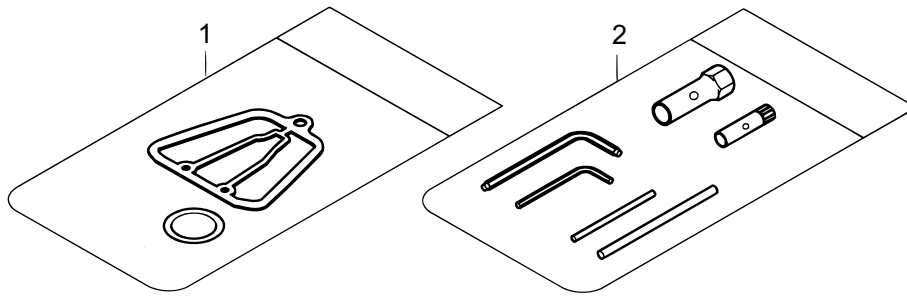

ROBIN D1B40T92040 — ACCESSORIES ASSY.

<u>NO.</u>	<u>PART NO.</u>	<u>PART NAME</u>	<u>QTY.</u>	<u>REMARKS</u>
1	01329701	ACCESSORIES KIT	1	
2	01330901	TOOL SET	1	
3	05110402	LABEL CHECK	1	
4	05130000	LABEL STARTING	1	
5	05130100	LABEL LIFTING	1	

ROBIN D1B40T92040 — CRANKCASE ASSY.

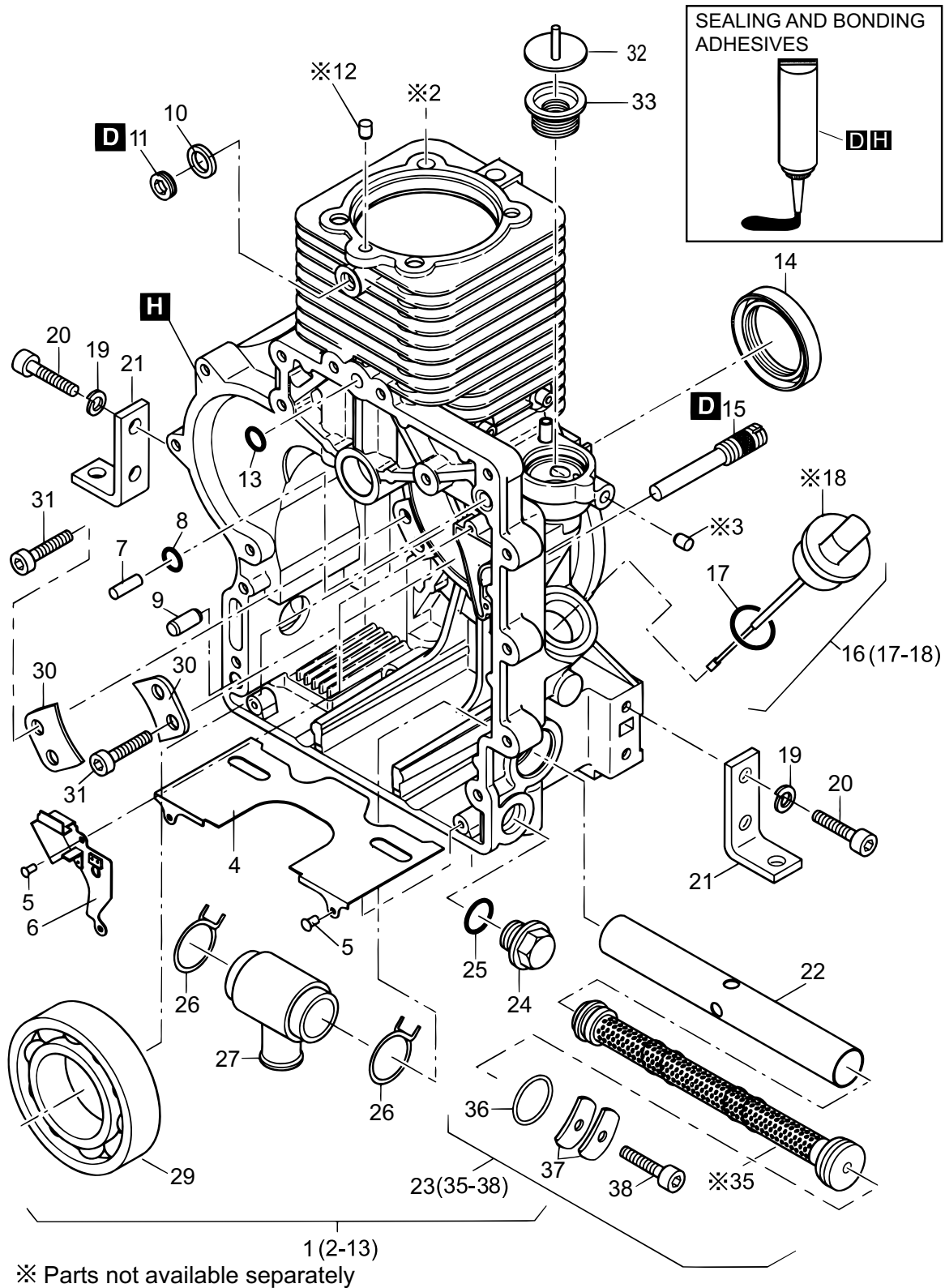

ROBIN D1B40T92040 — CRANKCASE ASSY.

<u>NO.</u>	<u>PART NO.</u>	<u>PART NAME</u>	<u>QTY.</u>	<u>REMARKS</u>
D	50223300	LOCTITE221 50ML	1	
H	50282501	SILICON 30ML	1	
1	01679100	CRANKCASE ASSY	1	INCLUDES ITEMS W/ #
2#		CRANKCASE.....	1	NOT SOLD SEPARATELY
3#		PLUG	1	NOT SOLD SEPARATELY
4#	04141600	COVER SHEET	1	
5#	40002600	BLIND RIVET3.2	1	
6#	01336400	COVER SHEET (SIDE)	4	
7#	50502801	CYL.PIN M6X24	1	
8#	50440300	O-RING 8X1.5	1	
9#	50249102	CYL.PIN M6X24	1	
10#	50062400	JOINT A10X13.5	1	
11#	50062300	CLOS.SCREW M10X1	1	
12#		PLUG	1	NOT SOLD SEPARATELY
13#	40022300	O-RING 8X2	1	
14	50479000	OIL SEAL 45X60X8	1	
15	04144401	GRUB SCREW	1	
16	01342800	DIPSTICK ASSY	1	INCLUDES ITEMS W/ \$
17\$	04125000	SEALING RING	1	
18\$		DIPSTICK	1	NOT SOLD SEPARATELY
19	50208500	SPRING WASHER 8	1	
20	04219500	ALLEN SCREW M8X40	1	
21	04144701	ENGINE BRACKET	1	
22	04141500	TUBE F.OIL FILTER	8	
23	01542702	OIL SUCTION FILTER ASSY	8	INCLUDES ITEMS W/ %
24	50373100	DRAIN PLG.MAGNT.M22	4	
25	50001600	JOINT A22X27	1	
26	05036900	HOSE CLIP	2	
27	04163000	T-PIECE	1	
29	50478900	GROOV.BALLBEAR.6310	1	
30	04133800	PLATE	3	
31	50564200	ALLEN SCREW M6X18	6	
32	01555800	COVER	1	
33	03568701	OIL SUPPLEMENT PLUG	1	
35%		FILTER, OIL SUCTION.....	1	NOT SOLD SEPARATELY
36%	50475901	O-RING 20X4	1	
37%	05148200	PLATE SPRING	2	
38%	50170700	ALLEN SCREW M6X16	1	

ROBIN D1B40T92040 — CRANKSHAFT ASSY.

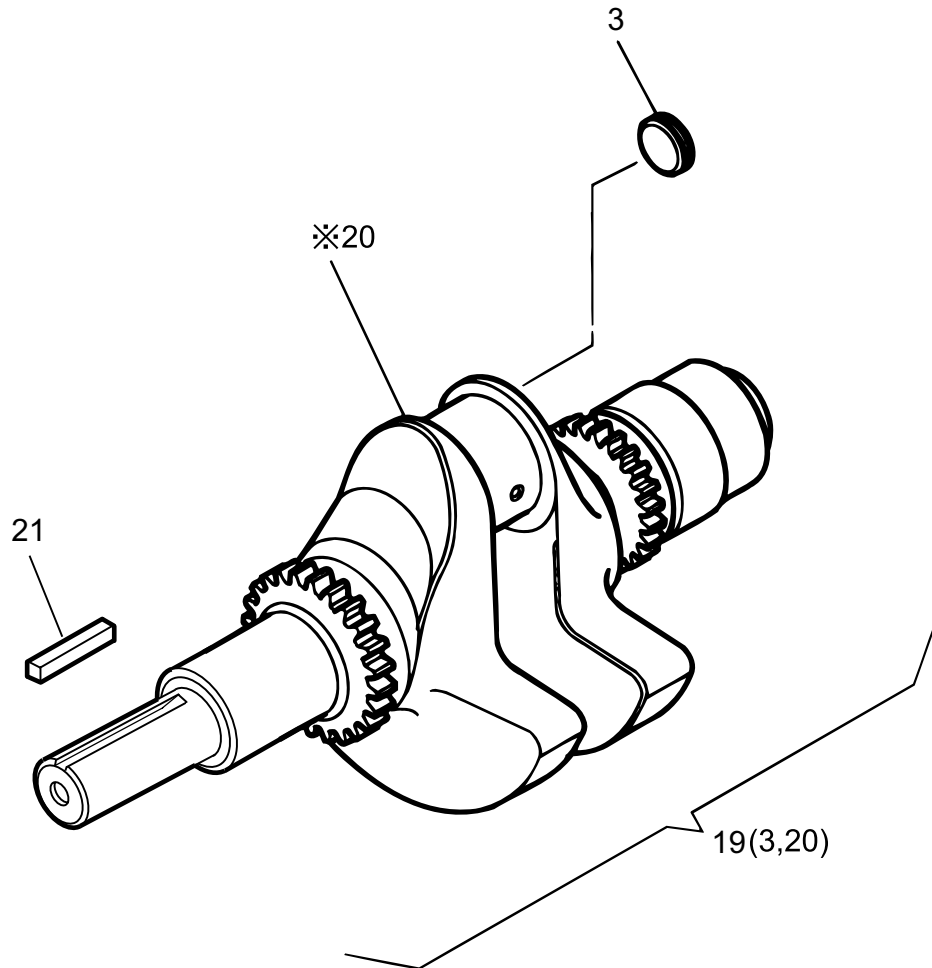

ROBIN D1B40T92040 — CRANKSHAFT ASSY.

<u>NO.</u>	<u>PART NO.</u>	<u>PART NAME</u>	<u>QTY.</u>	<u>REMARKS</u>
3#	50529700	COVER 14	1	
19	01896200	CRANKSHAFT ASSY.	1.....	INCLUDES ITEMS W/ #
20#		CRANKSHAFT.....	1.....	NOT SOLD SEPARATELY
21	05306100	KEY 7X7X35	1	

ROBIN D1B40T92040 — CAMSHAFT ASSY.

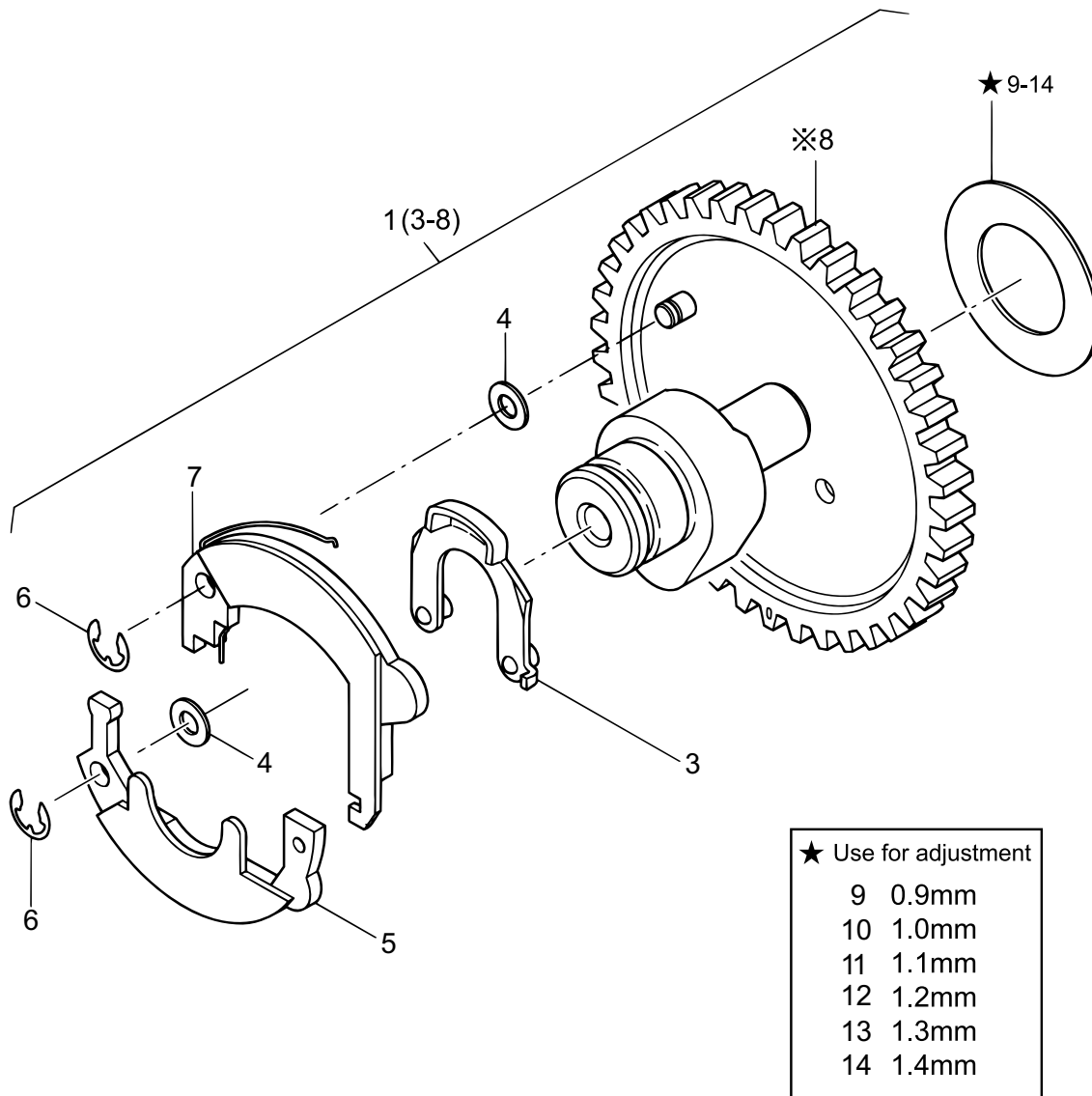

※ Parts not available separately

ROBIN D1B40T92040 — CAMSHAFT ASSY.

<u>NO.</u>	<u>PART NO.</u>	<u>PART NAME</u>	<u>QTY.</u>	<u>REMARKS</u>
1	01345003	CAMSHAFT ASSY.....	1.....	INCLUDES ITEMS W/ #
3#	01326401	CAMLEVER	1	
4#	50123200	SHIM 5X10X0.5	2	
5#	01326600	FLYWEIGHT	1	
6#	50255300	LOCKING WASHER 3.2	2	
7#	01326501	F.WEIGHT HAND-ST.	1	
8#		CAMSHAFT	1.....	NOT SOLD SEPARATELY
9	04121700	SHIM 23X38X0.9	1	
10	04112100	SHIM 23X38X1.0	1	
11	04112200	SHIM 23X38X1.1	1	
12	04112300	SHIM 23X38X1.2	1	
13	04125100	SHIM 23X38X1.3	1	
14	04125200	SHIM 23X38X1.4	1	

ROBIN D1B40T92040 — PISTON ASSY.

PISTON, CONROD, CYLINDER ASSY.

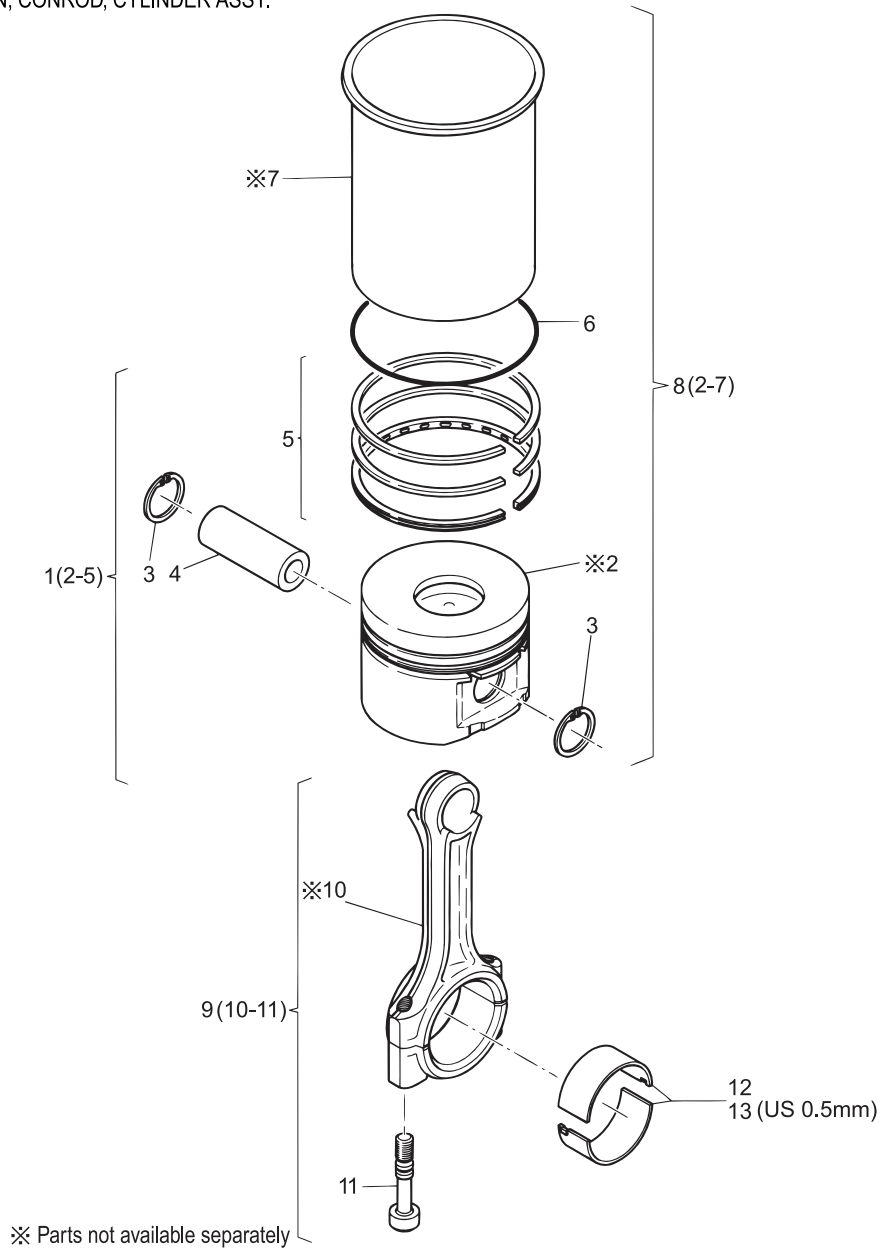

ROBIN D1B40T92040 — PISTON ASSY.

<u>NO.</u>	<u>PART NO.</u>	<u>PART NAME</u>	<u>QTY.</u>	<u>REMARKS</u>
1	01374810	PISTON ASSY 88 EPA2	1.....	INCLUDES ITEMS W/ %
2#%		PISTON.....	1.....	NOT SOLD SEPARATELY
3#%	50482300	CIRCLIP 22X1	2	
4#%	50527100	GUDGEON PIN	1	
5#%	01374701	PISTON RING SET 88	1	
6#	50479301	O-RING 93 X 1.5	1	
7#		CYLINDER.....	1.....	NOT SOLD SEPARATELY
8	01679610	CYLINDER W/ PISTON ASSY.....	1.....	INCLUDES ITEMS W/ #
9	01343500	CONROD ASSY	1.....	INCLUDES ITEMS W/ \$
10\$		CONROD	1.....	NOT SOLD SEPARATELY
11\$	04100500	CONROD SCREW	2	
12	01679800	BIG END BEARING	1	
13	01692700	BIG END BEAR.US0.5	1	

ROBIN D1B40T92040 — CYLINDER HEAD ASSY.

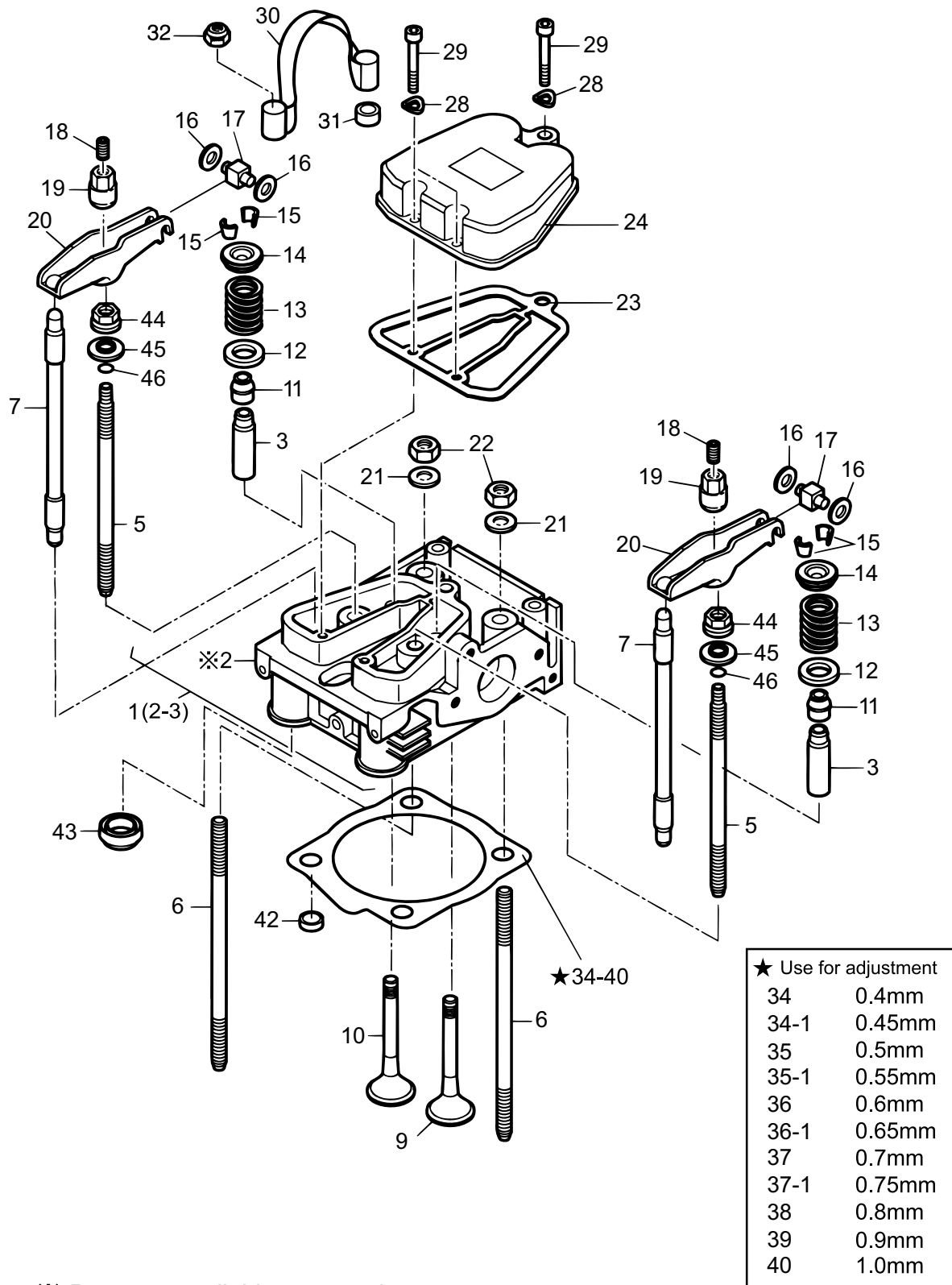

※ Parts not available separately

ROBIN D1B40T92040 — CYLINDER HEAD ASSY.

<u>NO.</u>	<u>PART NO.</u>	<u>PART NAME</u>	<u>QTY.</u>	<u>REMARKS</u>
1	01850900	CYLINDER HEAD ASSY EPA2	1.....	INCLUDES ITEMS W/ #
2#		CYLINDER HEAD.....	1.....	NOT SOLD SEPARATELY
3#	05209700	VALVE GUIDE	2	
5	05159600	STUD CYL.HEAD	2	
6	05159700	STUD CYL.HEAD	2	
7	01374000	PUSHROD	2	
9	05145100	VALVE INLET	1	
10	05145200	VALVE EXHAUST	1	
11	50425800	STEM SEAL CAP	2	
12	04147100	WASHER	2	
13	04146900	VALVE SPRING	2	
14	04147000	SPRING PLATE	2	
15	50425700	COLLET	2	
16	05240700	SUPP.DISC 6X12X1.35	4	
17	05091101	SLIDER	2	
18	50513100	GRUB SCREW M8X10	2	
19	05054700	NUT F. ROCKERARM	2	
20	05146701	ROCKER	2	
21	05099300	WASHER 10.1X24X3	2	
22	50396600	HEXAGON NUT M 10	2	
23	05156401	GASKET CYL.HEAD	1	
24	05146501	COVER F.CYL.HEAD	1	
28	50081200	SPRING WASHER A 6	3	
29	50374900	ALLEN SCREW M 6X35	3	
30	04117701	LIFTING STRAP	1	
31	04126100	PROTECTION HOSE	2	
32	40028600	HEX.NUT M10	2	
34	05158903	GASKET F.CYL.HEAD 0.4	1	
34-1	04248400	GASKET F.CYL.H. 0.45	1	
35	04248500	GASKET F.CYL.H. 0.55	1	
35-1	04248500	GASKET F.CYL.H. 0.55	1	
36	05159103	GASKET F.CYL.HEAD 0.6	1	
36-1	04248600	GASKET F.CYL.H. 0.65	1	
37	05159203	GASKET F.CYL.HEAD 0.7	1	
37-1	04248700	GASKET F.CYL.H. 0.75	1	
38	05159303	GASKET F.CYL.HEAD 0.8	1	
39	05159403	GASKET F.CYL.HEAD 0.9	1	
40	05159503	GASKET F.CYL.HEAD 1.0	1	
42	04174500	CENTR.BUSH	2	
43	04106500	SEALING RING TIM.COV.	2	
44	03171800	COLLAR NUT	2	
45	04243700	DISC 8.1X12X2.0	2	
46	50563900	O-RING 10X2.5	2	

ROBIN D1B40T92040 — OIL PUMP AND GOV. ASSY.

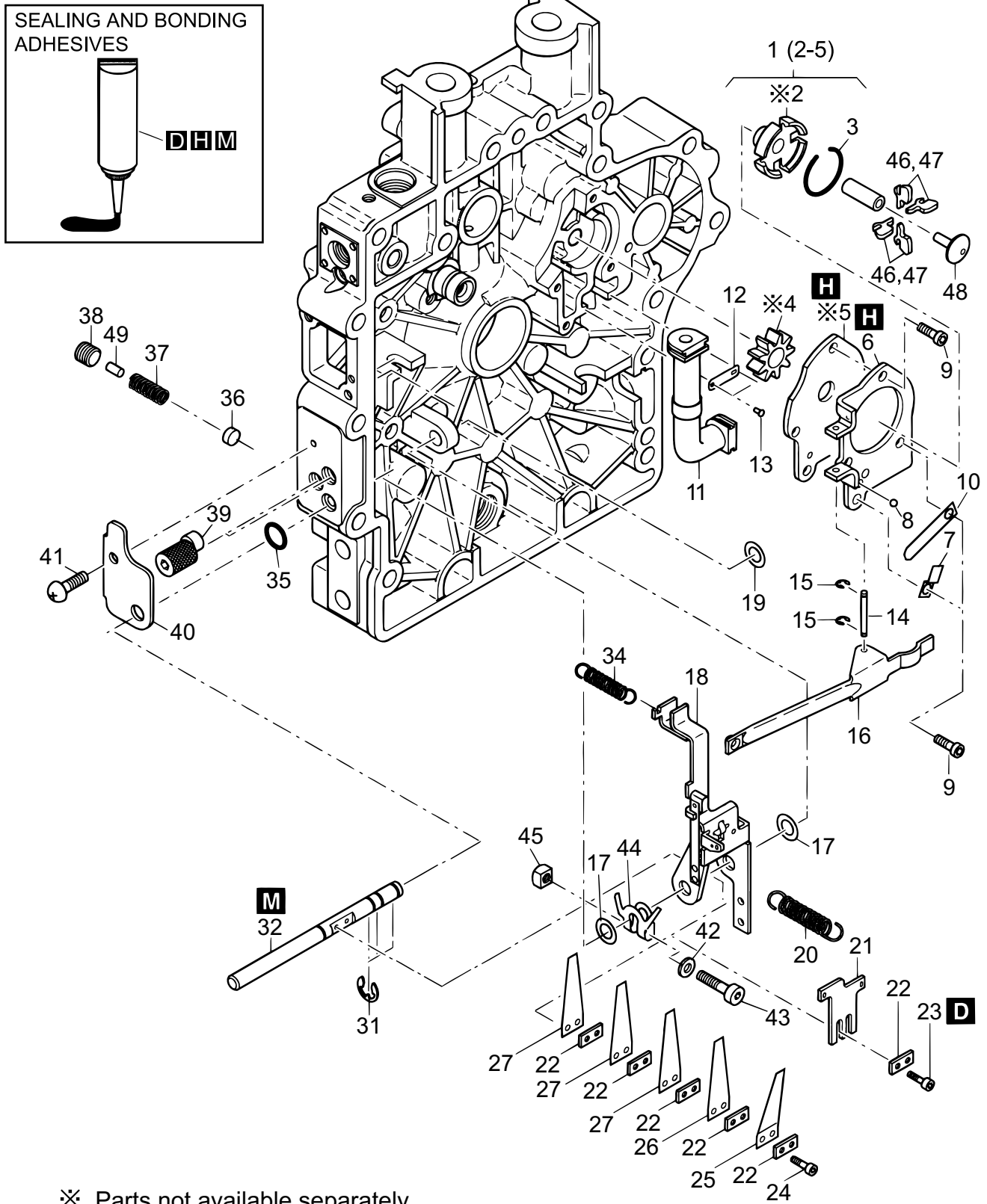

ROBIN D1B40T92040 — OIL PUMP AND GOV. ASSY.

<u>NO.</u>	<u>PART NO.</u>	<u>PART NAME</u>	<u>QTY.</u>	<u>REMARKS</u>
D	50223300	LOCTITE221 50ML	1	
H	50282501	SILICON 30ML	1	
M	50485100	SCHLEIF PASTE 80G	1	
1	01344510	OILPUMP CP. ASSY	1	INCLUDES ITEMS W/ #
2#		OIL PUMP	1	NOT SOLD SEPARATELY
3#	04210910	CIRCLIP	1	
4#		GEAR, OIL PUMP.....	1	NOT SOLD SEPARATELY
5#		HOUSING, OIL PUMP	1	NOT SOLD SEPARATELY
6	05078110	COVER, OIL PUMP	1	
7	05097100	RETAINING STRAP	1	
8	50447900	BALL 3.5 MM G100	1	
9	50429400	ALLEN SCREW M5X12	4	
10	05097300	FLAT SPRING 0.4	1	
11	01346000	TUBE OIL SUCTION	1	
12	04153400	FISHPLATE	1	
13	40002600	BLINDRIVET3.2	2	
14	05078600	SHAFT	1	
15	50434800	CIRCLIP 1.9	2	
16	01345901	LEVER	1	
17	50422400	SHIM 8X14X1	2	
18	01365200	GOVERNOR LEVER	1	
19	50125800	DISC 8X14X0.5	1	
20	05130910	GOVERNOR SPRING	1	
21	05130800	STOP	1	
22	05079800	INTERMEDIATE PLATE	1	
23	50465300	ALLEN SCREW M3X8	2	
24	50435000	ALLEN SCREW M3X12	2	
25	05148600	STOP SPRING	1	
26	05078900	GOV. SPRING 0.3	1	
27	05131600	GOV. SPRING 0.2	1	
31	50092700	CIRCLIP 7	1	
32	05079301	SHAFT	1	
34	50563400	TENSION SPRING	1	
35	40022401	O-RING 8X2 GRAY	1	
36	05151700	PLUG	1	
37	50488700	PRESSURE SPRING	1	
38	50475700	GRUB SCREW M10X10	4	
39	05178810	ECCENTRIC SCREW	1	
40	05178400	PLATE	1	
41	50492300	FILL.HEAD SCREW M5X12	1	
42	50216300	WASHER 5.3	2	
43	50492200	ALL.SCR. M5X25	1	
44	05178500	STOP	2	
45	50422700	SQUARE NUT M5	1	
46	05079611	CENTRIFUGAL WEIGHT	2	
47	05160211	CENTRIFUGAL WEIGHT	1	
48	05078502	GOVERNOR SLEEVE	1	
49	50057900	CYL.PIN 4 M6X8	1	

ROBIN D1B40T92040 — TIMING ASSY.

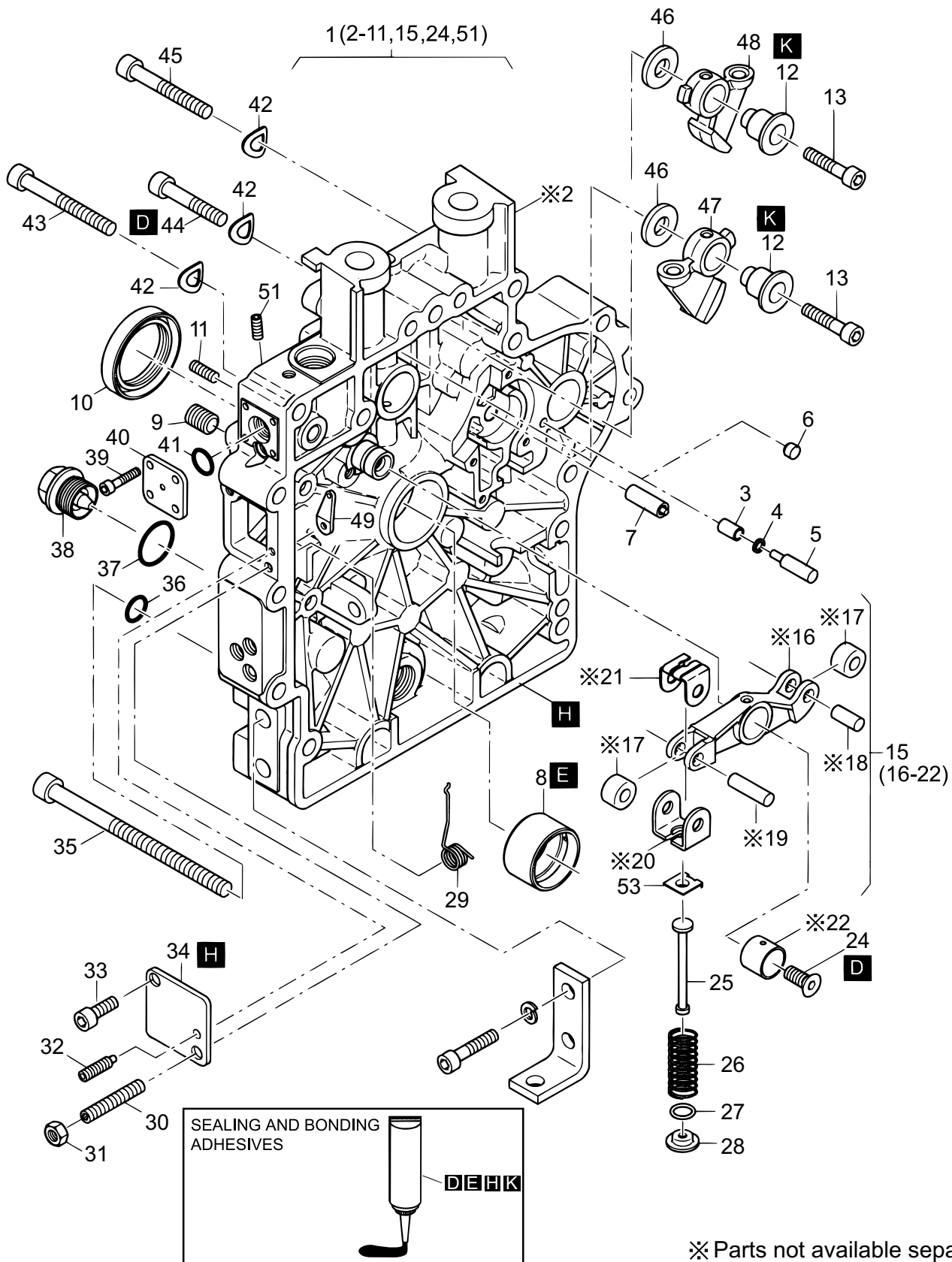

ROBIN D1B40T92040 — TIMING ASSY.

<u>NO.</u>	<u>PART NO.</u>	<u>PART NAME</u>	<u>QTY.</u>	<u>REMARKS</u>
D	50223300	LOCTITE221 50ML	1	
D	50223300	LOCTITE221 50ML	1	
E	50223400	LOCTITE648 10ML	1	
H	50282501	SILICON 30ML	1	
K	50342601	HOCHTEMP.FETT 400G	1	
1	01894200	TIMING COVER CP. ASSY	1.....	INCLUDES ITEMS W/ #
2#		TIMING COVER.....	1.....	NOT SOLD SEPARATELY
3#	04185800	CLOSING PLUG	1	
4#	50464100	O-RING 2X1	1	
5#	04185700	CLOSING PLUG 4X15	1	
6#	04168600	PLUG 4.3	1	
7#	01344600	BOLT F.GOV.HOUSING	1	
8#	04148800	MAIN BEARING	1	
9#	50530600	GRUB SCREW M8X10	4	
10#	50479500	OIL SEAL 35X47X7	1	
11#	50400600	GRUB SCREW M 5X10	2	
12	03794201	CAM FOLLOW SP.	2	
13	50469900	ALLEN SCREW M6X30	2	
15#	01346710	ROCKER LEVER ASSY	1.....	INCLUDES ITEMS W/ \$
16\$		ROCKER LEVER.....	1.....	NOT SOLD SEPARATELY
17\$		BUSHING, ROCKER LEVER	1.....	NOT SOLD SEPARATELY
18\$		PIN, ROCKER LEVER.....	1.....	NOT SOLD SEPARATELY
19\$		PIN, ROCKER LEVER.....	1.....	NOT SOLD SEPARATELY
20\$		CLAMP, ROCKER LEVER.....	1.....	NOT SOLD SEPARATELY
21\$		CLAMP, ROCKER LEVER.....	1.....	NOT SOLD SEPARATELY
22\$		SPINDLE.....	1.....	NOT SOLD SEPARATELY
24#	50561800	CTR.SUNK SCREW M6X40	1	
25	04094700	DRAW ROD	1	
26	04095700	PRESSURE SPRING	1	

ROBIN D1B40T92040 — TIMING ASSY. (CONTINUED)

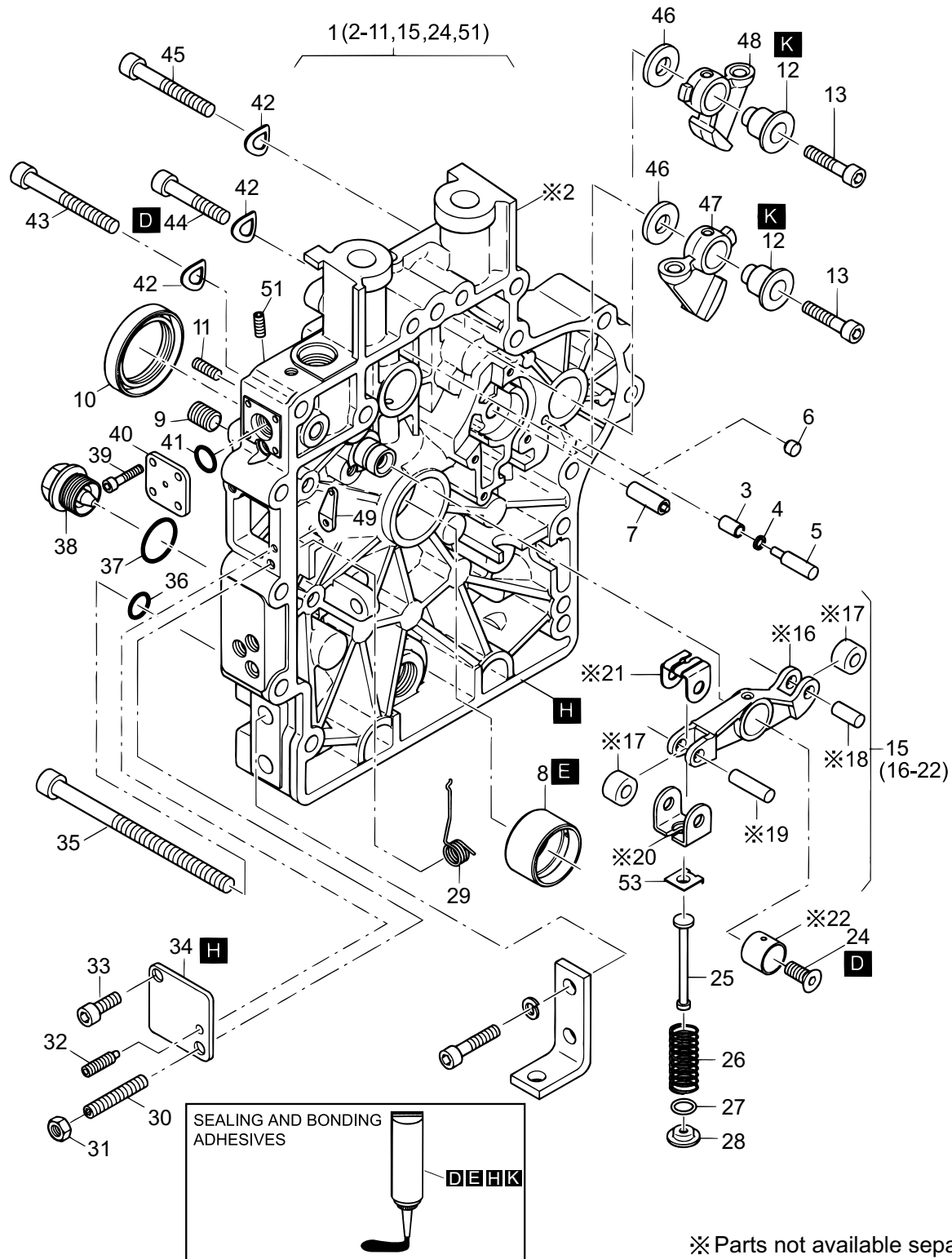

ROBIN D1B40T92040 — TIMING ASSY. (CONTINUED)

<u>NO.</u>	<u>PART NO.</u>	<u>PART NAME</u>	<u>QTY.</u>	<u>REMARKS</u>
27	04133900	DISC 10.7X19X0.5	1	
28	04094802	CUP	1	
29	05095210	SPRING F.GOVERNOR	1	
30	50499300	GRUB SCREW M6X35	1	
31	50144400	HEXAGON NUT M6	1	
32	50499400	GRUB SCREW M4X25	1	
33	50384200	ALLEN SCREW M6X12	1	
34	04095210	COVER	1	
35	50463000	ALLEN SCREW M8X130	2	
36	50162900	JOINT A8X14	2	
37	50459100	JOINT A22X27	1	
38	50373100	DRAIN PLG.MAGNT.M22	1	
39	50397100	ALLEN SCREW M4X10	4	
40	01351700	COVER	1	
41	50329000	O-RING 9.5X2.5	1	
42	50095100	SPRING WASHER A8	15	
43	50288800	ALLEN SCREW M8X55	11	
44	50177500	ALLEN SCREW M8X40	2	
45	50392900	ALLEN SCREW M8X50	2	
46	03794100	WASHER	2	
47	04146600	CAM FOLLOWER	1	
48	04146000	CAM FOLLOWER	1	
49	05127100	LEVER	1	
51#	50262400	THREADED PIN M6X10	1	
53	04189500	CUP	1	

ROBIN D1B40T92040 — BLOWER FLYWHEEL & ALT. ASSY.

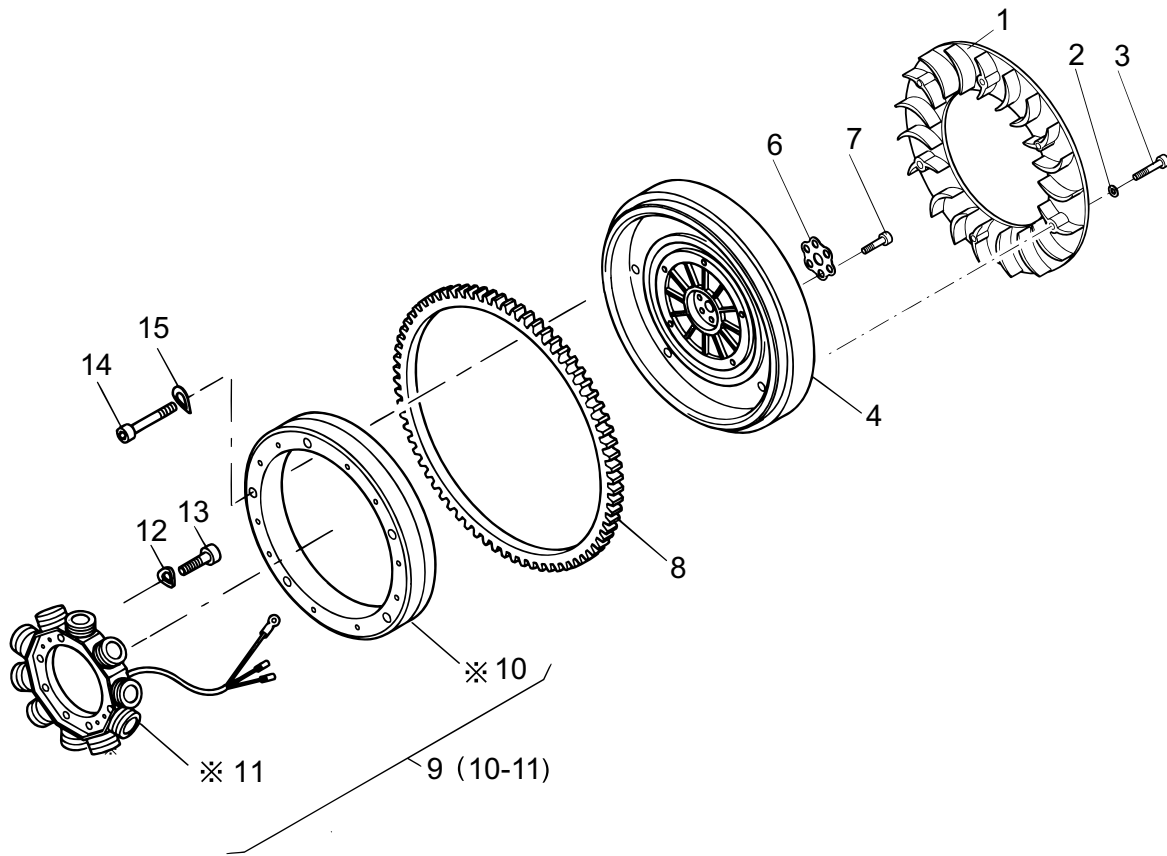

※ Parts not available separately

ROBIN D1B40T92040 — BLOWER FLYWHEEL & ALT. ASSY.

<u>NO.</u>	<u>PART NO.</u>	<u>PART NAME</u>	<u>QTY.</u>	<u>REMARKS</u>
1	04205800	BLOWER RING	1	
2	50003400	SPRING WASHER A4	6	
3	50327300	ALLEN SCREW M4X20	6	
4	04161502	FLYWHEEL	1	
6	04155101	PLATE	1	
7	50502501	ALLEN SCREW M8X35	6	
8	04151100	GEAR RING	1	
9	01926100	ALTERNATOR ASSY 12V 200W	1.....	INCLUDES ITEMS W/ #
10#		FLYWHEEL COVER	1.....	NOT SOLD SEPARATELY
11#		ALTERNATOR.....	1.....	NOT SOLD SEPARATELY
12	50081900	SPRING WASHER A5	4	
13	50547000	ALLEN SCREW M5X25	4	
14	50236600	ALLEN SCREW M6X25	5	
15	50081200	SPRING WASHER A6	5	

ROBIN D1B40T92040 — INJECTION EQUIPMENT ASSY.

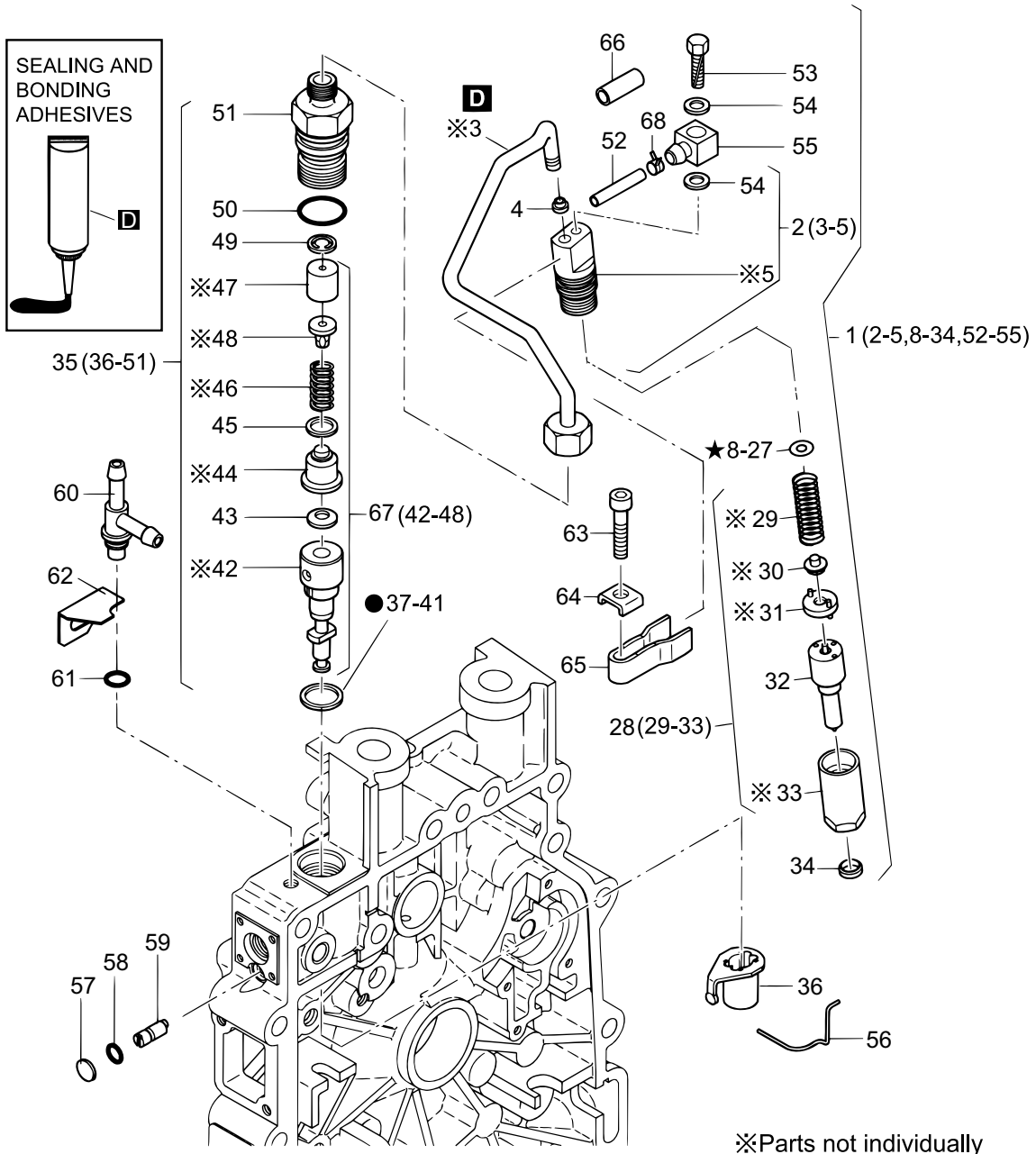

● Use for adjustment

37	0.2mm
38	0.3mm
39	0.4mm
40	0.5mm
41	0.6mm

★ Use for adjustment

8	1.00mm	13	1.24mm	18	1.50mm	23	1.74mm
9	1.04mm	14	1.30mm	19	1.54mm	24	1.80mm
10	1.10mm	15	1.34mm	20	1.60mm	25	1.84mm
11	1.14mm	16	1.40mm	21	1.64mm	26	1.90mm
12	1.20mm	17	1.44mm	22	1.70mm	27	1.94mm

ROBIN D1B40T92040 — INJECTION EQUIPMENT ASSY.

<u>NO.</u>	<u>PART NO.</u>	<u>PART NAME</u>	<u>QTY.</u>	<u>REMARKS</u>
D	50223300	LOCTITE221 50ML	1	
1	01389700	INJECTOR CPL.	1	INCLUDES ITEMS W/ %
2%	01680600	NOZZLE HOLD.+PIPE	1	INCLUDES ITEM W/ &
3%&		PIPE.....	1	NOT SOLD SEPARATELY
4%&	05070601	SEALING CONE	1	
5%&		NIPPLE BODY	1	NOT SOLD SEPARATELY
8%	50436400	SHIM 1.0	1	
9%	50436500	SHIM 1.04	1	
10%	50436600	SHIM 1.10	1	
11%	50436700	SHIM 1.14	1	
12%	50436800	SHIM 1.20	1	
13%	50436900	SHIM 1.24	1	
14%	50437000	SHIM 1.30	1	
15%	50437100	SHIM 1.34	1	
16%	50437200	SHIM 1.40	1	
17%	50437300	SHIM 1.44	1	
18%	50437400	SHIM 1.50	1	
19%	50437500	SHIM 1.54	1	
20%	50437600	SHIM 1.60	1	
21%	50437700	SHIM 1.64	1	
22%	50437800	SHIM 1.70	1	
23%	50437900	SHIM 1.74	1	
24%	50438000	SHIM 1.80	1	
25%	50438100	SHIM 1.84	1	
26%	50438200	SHIM 1.90	1	
27%	50438300	SHIM 1.94	1	
28%	01389900	PARTS SET NOZZLE ASSY EPA	1	INCLUDES ITEMS W/ \$
29\$%		SPRING	1	NOT SOLD SEPARATELY
30\$%		SPRING WASHER.....	1	NOT SOLD SEPARATELY
31\$%		PLATE.....	1	NOT SOLD SEPARATELY
32\$%	50566600	NOZZLE	1	
33\$%		BODY	1	NOT SOLD SEPARATELY

ROBIN D1B40T92040 — INJECTION EQUIP. ASSY. (CONT.)

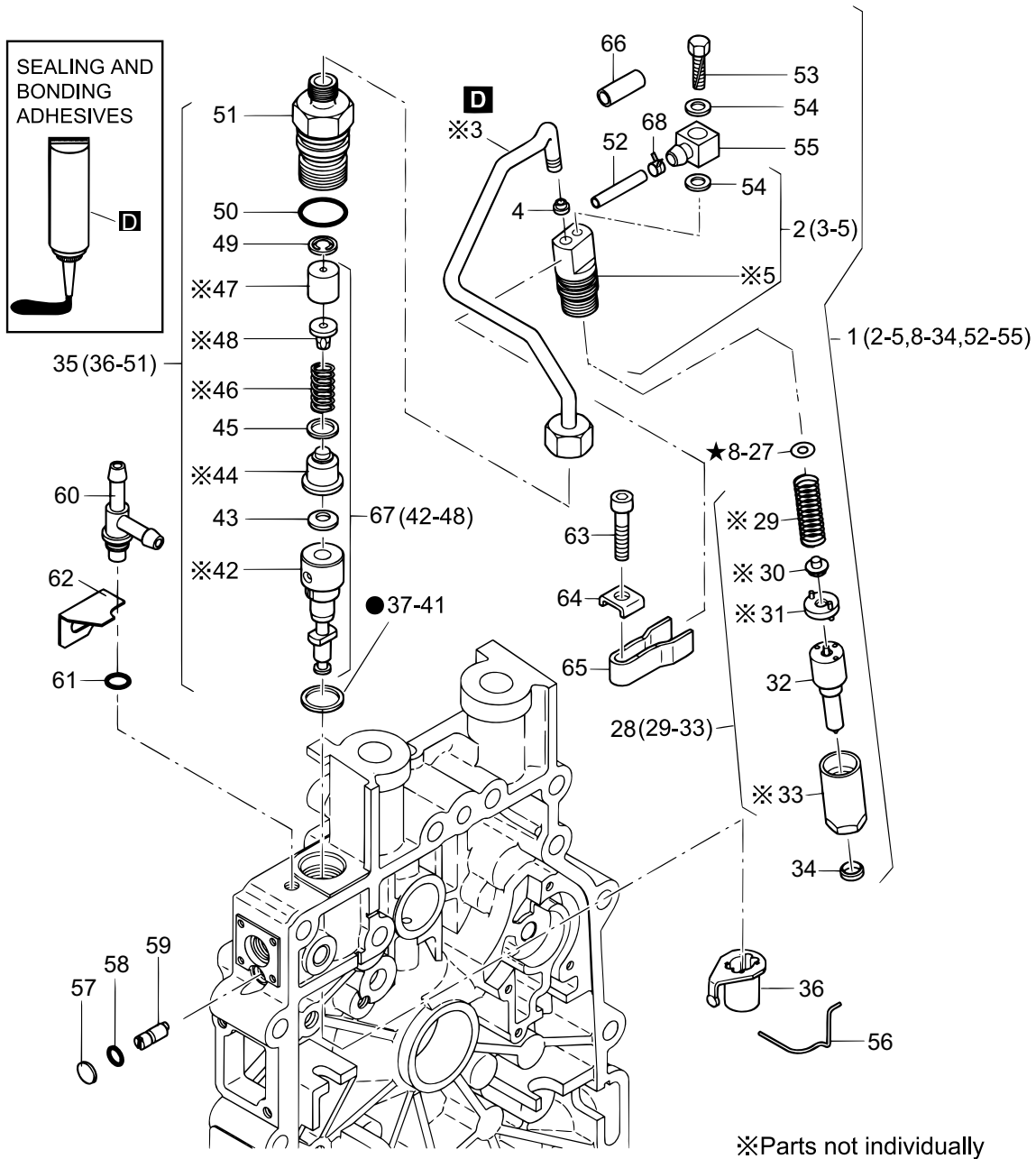

● Use for adjustment	
37	0.2mm
38	0.3mm
39	0.4mm
40	0.5mm
41	0.6mm

★ Use for adjustment					
8	1.00mm	13	1.24mm	18	1.50mm
9	1.04mm	14	1.30mm	19	1.54mm
10	1.10mm	15	1.34mm	20	1.60mm
11	1.14mm	16	1.40mm	21	1.64mm
12	1.20mm	17	1.44mm	22	1.70mm
				23	1.74mm
				24	1.80mm
				25	1.84mm
				26	1.90mm
				27	1.94mm

ROBIN D1B40T92040 — INJECTION EQUIP. ASSY. (CONT.)

<u>NO.</u>	<u>PART NO.</u>	<u>PART NAME</u>	<u>QTY.</u>	<u>REMARKS</u>
34%	05070500	JOINT WASH.F.INJECT	1	
35	01680810	FUEL INJECTOR PUMP CP.....	1	INCLUDES ITEMS W/ @
36@	01330801	CONTROL SLEEVE	1	
37@	04096300	SHIM 14X18X0.2	1	
38@	04096400	SHIM 14X18X0.3	1	
39@	04096500	SHIM 14X18X0.4	1	
40@	04096600	SHIM 14X18X0.5	1	
41@	04096700	SHIM 14X18X0.6	1	
42#@		VALVE, FUEL INJECTOR PUMP.....	1	NOT SOLD SEPARATELY
43#@	04165200	CON.SPR.WASHER 8	1	
44#@		BODY, FUEL INJECTOR PUMP.....	1	NOT SOLD SEPARATELY
45#@	50476900	JOINT WASHER	1	
46#@		SPRING, FUEL INJECTOR PUMP.....	1	NOT SOLD SEPARATELY
47#@		VALVE, FUEL INJECTOR PUMP.....	1	NOT SOLD SEPARATELY
48#@		BODY, FUEL.....	1	NOT SOLD SEPARATELY
49@	05180800	VALVE PLATE	1	
50@	50489200	O-RING 17X2	1	
51@	05181100	DELIV.VALVE HOLDER	1	
52%	05215000	HOSE 2.5X195	1	
53%	50464500	HEXSCREW A M4X16	1	
54%	50110800	JOINT A4X8	2	
55%	05129000	CONNECTING NIPPLE	1	
56	04161800	HOLDING SPRING	1	
57	50476000	DISC 8	1	
58	50330100	O-RING 4X1.2	1	
59	04097710	ECCENTRIC PIN	1	
60	01756800	NIPPLE	1	
61	50154300	O-RING 7.5X10.5X1.5	1	
62	05183100	SUPPORT	1	
63	50323900	ALL.SCR. M6X30	1	
64	05089300	RETAINING YOKE	1	
65	05056700	FORK F. INJECTOR	1	
66	05267900	INSUL.HOSE 120MM	1	
67	01828510	F. INJ.PUMP BODY.....	1	INCLUDES ITEMS W/ #
68	50577900	CLAMP 0.5X6.0XA6.0	1	

ROBIN D1B40T92040 — RECOIL STARTER ASSY.

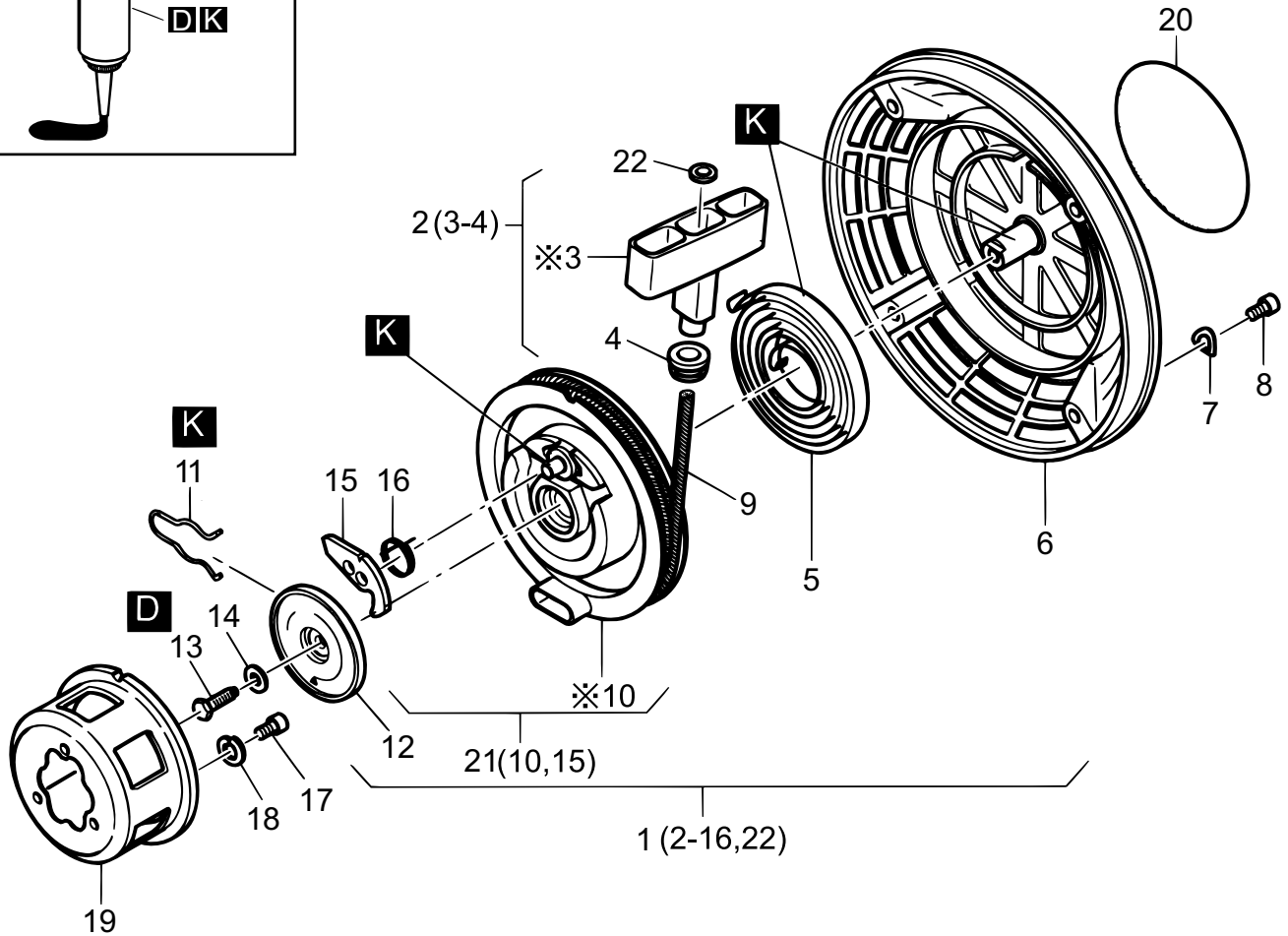
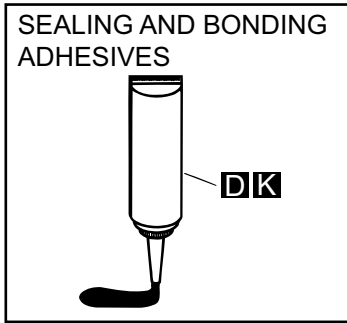

※ Not available separately

ROBIN D1B40T92040 — RECOIL STARTER ASSY.

<u>NO.</u>	<u>PART NO.</u>	<u>PART NAME</u>	<u>QTY.</u>	<u>REMARKS</u>
D	50223300	LOCTITE221 50ML	1	
K	50342601	HOCHTEMP.FETT 400G	1	
1	01851900	RECOIL-STARTER	1	INCLUDES ITEMS W/ %
2%	01497800	HANDLE ASSY.	1	INCLUDES ITEMS W/ #
3%#		HANDLE	1	NOT SOLD SEPARATELY
4%#	03665200	RUBBER SLEEVE	1	
5%	05045201	RETURN SPRING	1	
6%	01569300	HOUSING F.R.START	1	
7%	50081200	SPRING WASHER A6	4	
8%	50062700	ALLEN SCREW M6X10	4	
9%	05088901	ROPE F.R.START	1	
10%\$		ROPE PULLEY	1	NOT SOLD SEPARATELY
11%	05044901	BRAKE SPRING	1	
12%	05045001	BRAKE DISC	1	
13%	50146300	HEX SCREW M6X18	1	
14%	50390701	CON.SPR.WASHER 6	1	
15%\$	05044800	RATCHET	1	
16%	05061300	RETURN SPRING	1	
17	50062700	ALLEN SCREW M6X10	3	
18	50170900	SPRING WASHER 6	3	
19	04155000	DRIVING SLEEVE	1	
20	05298100	STICKER LABEL	1	
21	01548800	ROPE PULLEY	1	INCLUDES ITEM W/ \$
22%	50514600	WASHER 5.3	1	

ROBIN D1B40T92040 — AIR DUCTING (A) ASSY.

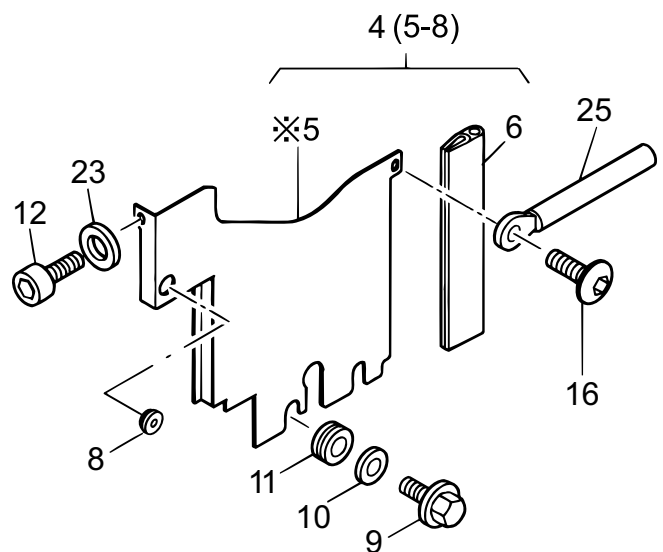
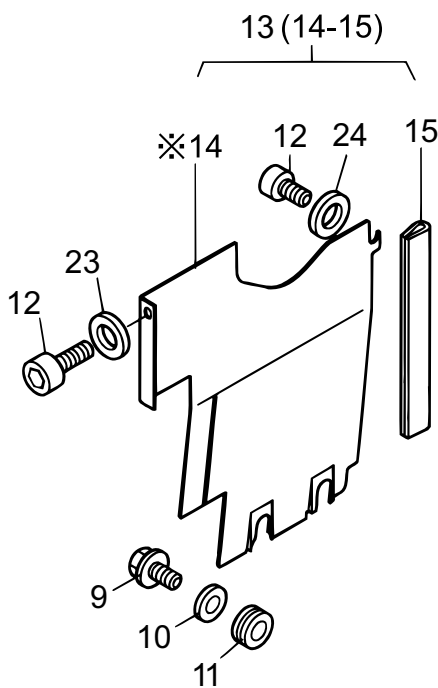
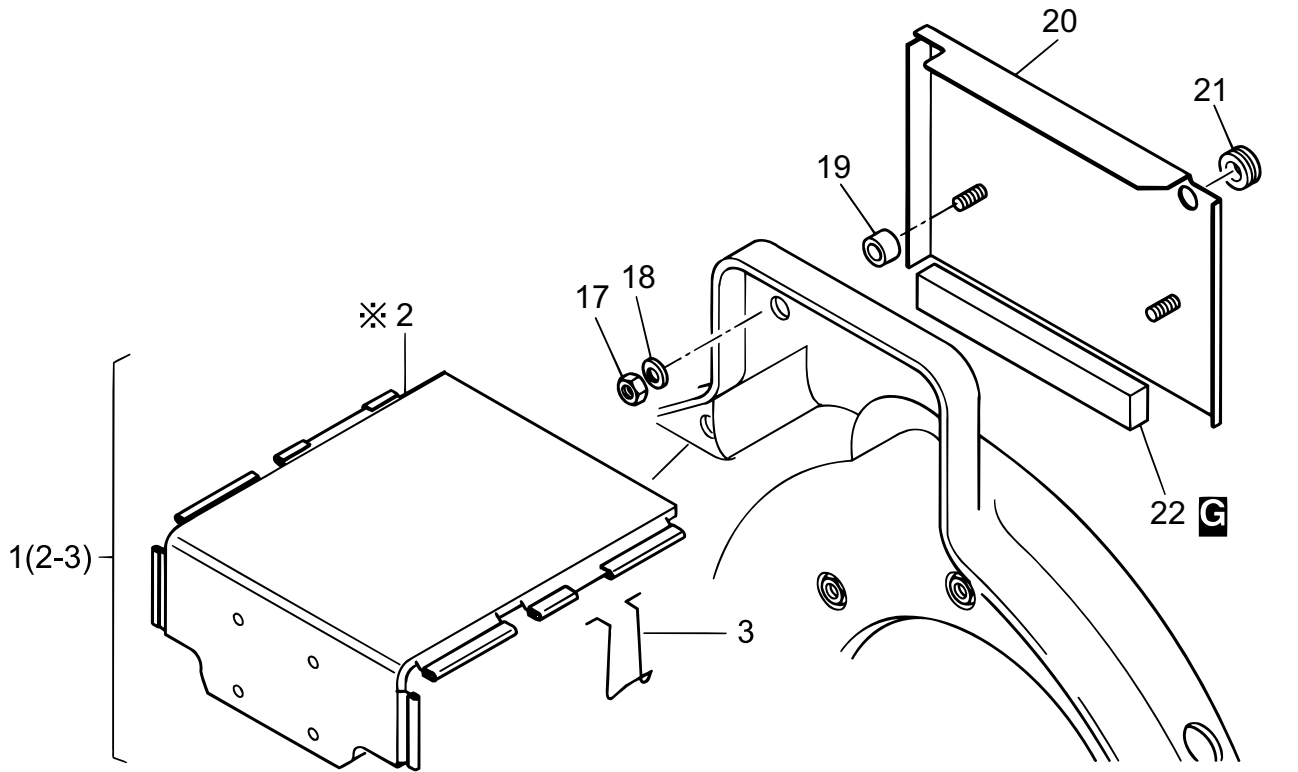

※ Parts not available separately

ROBIN D1B40T92040 — AIR DUCTING (A) ASSY.

<u>NO.</u>	<u>PART NO.</u>	<u>PART NAME</u>	<u>QTY.</u>	<u>REMARKS</u>
G	50256501	LOCTITE IS407 20G	1	
1	01853100	HOOD ASSY.....	1	INCLUDES ITEM W/ #
2#		HOOD	1	NOT SOLD SEPARATELY
3#	05152100	SPRING CLIP	1	
4	01345400	COOLING AIR DUCT ASSY.....	1	INCLUDES ITEM W/ \$
5\$		AIR DUCT	1	NOT SOLD SEPARATELY
6\$	04144200	SEALING STRIP119MM	1	
8\$	50334800	RUBBER SLEEVE	1	
9	50445401	FILL.HEAD SCREW M4X10	4	
10	50441600	WASHER 4.3	4	
11	50163801	RUBBER SLEEVE	4	
12	50528100	ALLEN SCREW M6X16	3	
13	01345300	COOLING AIR DUCT ASSY.....	1	INCLUDES ITEMS W/ %
14%		AIR DUCT	1	NOT SOLD SEPARATELY
15%	04144200	SEALING STRIP119MM	1	
16	50495000	SCREW M6X12	1	
17	50144400	HEXAGON NUT M6	2	
18	50170900	SPRING WASHER 6	2	
19	03354600	SPACER BUSH	2	
20	01698200	COVER	1	
21	50334800	RUBBER SLEEVE	1	
22	03577200	SEALING STRIP	1	
23	50144500	FLAT WASHER 6.4	2	
24	04060600	WASHER 6.4X16X1.5	1	
25	05001200	CLIP	1	

ROBIN D1B40T92040 — AIR DUCTING (B) ASSY.

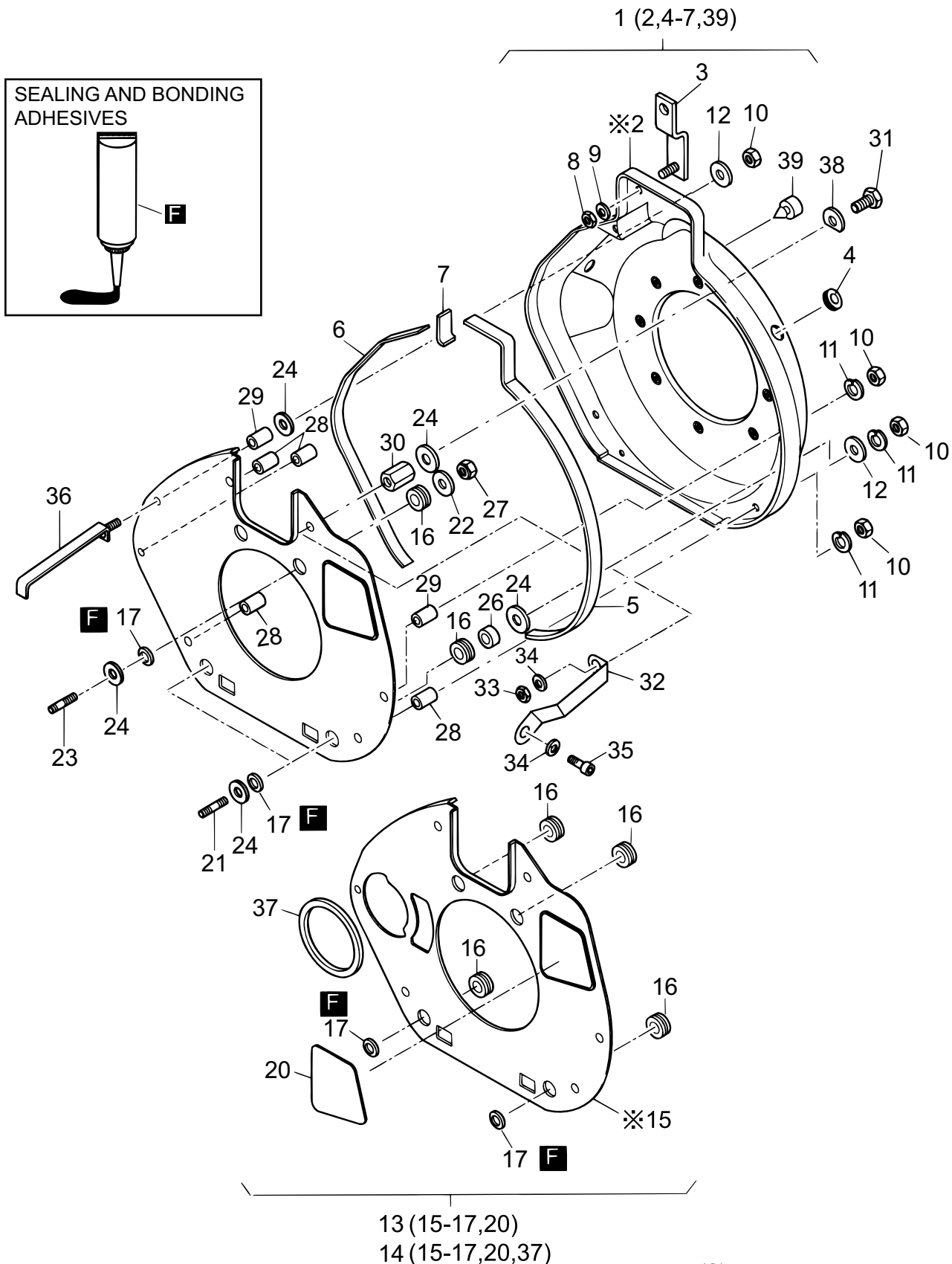

※ Parts not available separately

ROBIN D1B40T92040 — AIR DUCTING (B) ASSY.

<u>NO.</u>	<u>PART NO.</u>	<u>PART NAME</u>	<u>QTY.</u>	<u>REMARKS</u>
F	50223800	TECHNICOLL8058 0.75KG	1	
1	01831300	BLOWER DUCTING ASSY	1	INCLUDES ITEMS W/ #
2#		BLOWER DUCTING	1	NOT SOLD SEPARATELY
3	01331300	SUPPORT	2	
4#	50453300	RUBBER SLEEVE	1	
5#	05189400	SEALING STRIP 655MM	1	
6#	05189300	SEALING STRIP	1	
7#	05227000	SEALING STRIP 54MM	1	
8	50144400	HEXAGON NUT M6	2	
9	50170900	SPRING WASHER 6	2	
10	50144400	HEXAGON NUT M6	7	
11	50170900	SPRING WASHER 6	8	
12	50120000	DISC A6.4	3	
13	01661900	PARTING SHEET ASSY	1	INCLUDES ITEMS W/ \$
14	01347600	PARTING SHEET ASSY E-ST.NO FT	1	INCLUDES ITEMS W/ %
15\$%		PARTING SHEET	1	NOT SOLD SEPARATELY
16\$%	01378300	SPACER BUSH	4	
17\$%	03575500	RUBBER SEAL RING	4	
20\$%	04215200	CLOSING COVER	1	
21	50458100	STUD M6 X45	2	
22	50114300	DISC 6.4	2	
23	50464401	STUD M6FO X35	2	
24	04042000	WASHER 6.5X22.5X1	7	
26	05188600	SPACER BUSH 7X12X7	2	
27	50328300	HEXAGON NUT VM6	2	
28	04139000	SPAC.TUBE 6.5X12X18	4	
29	04098400	SPAC.TUBE 7X12X16.3	2	
30	05184000	HEXAGON NUT M6X17	1	
31	50026400	HEXSCREW M6X35	1	
32	01669400	SUPPORT	1	
33	50144400	HEXAGON NUT M6	1	
34	50170900	SPRING WASHER 6	2	
35	50170700	ALLEN SCREW M6X16	1	
36	01683300	SUPPORT	1	
37%	04099500	SEALING RING	1	
38	05140900	WASHER	1	
39#	50392610	RUBBER BUSH	1	

ROBIN D1B40T92040 — CRANKCASE BREATHING SYS. ASSY.

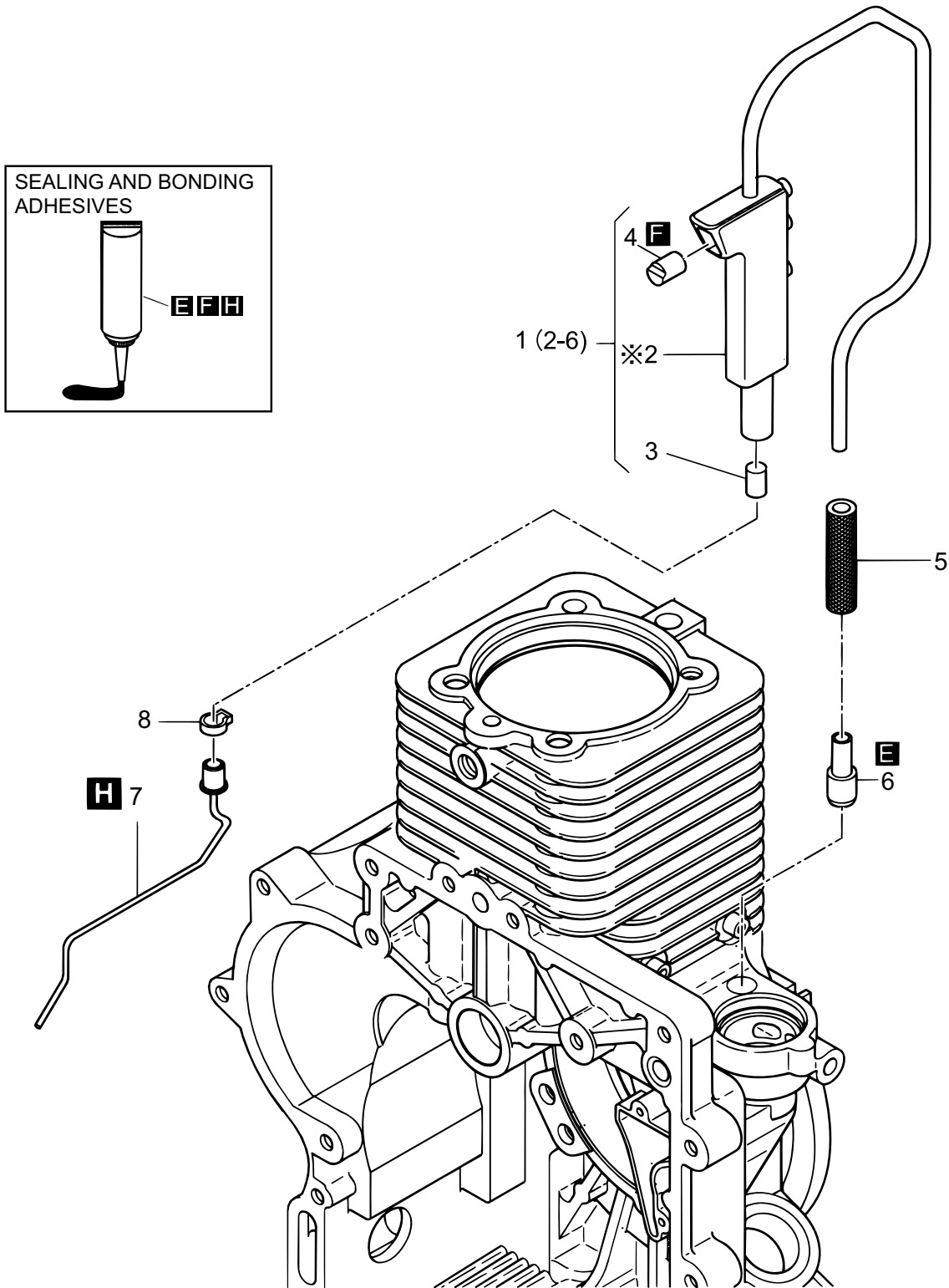

※ Parts not available separately

ROBIN D1B40T92040 — CRANKCASE BREATHING SYS. ASSY.

<u>NO.</u>	<u>PART NO.</u>	<u>PART NAME</u>	<u>QTY.</u>	<u>REMARKS</u>
E	50223400	LOCTITE648 10ML	1	
F	50223800	TECHNICOLL8058 0.75KG	1	
H	50282501	SILICON 30ML	1	
1	01885800	CRANKCASE BREATHER CP	1.....	INCLUDES ITEMS W/ #
2#		OIL SEPARATOR.....	1.....	NOT SOLD SEPARATELY
3#	05102900	FILTER BREATHING SYSTEM	1	
4#	05098100	PLUG	1	
5#	05197200	FUEL PIPE LW 7X35	1	
6#	05196000	NIPPLE	1	
7	01626900	SUCTION PIPE	1	
8	50456800	CLAMP	1	

ROBIN D1B40T92040 — FUEL TANK ASSY.

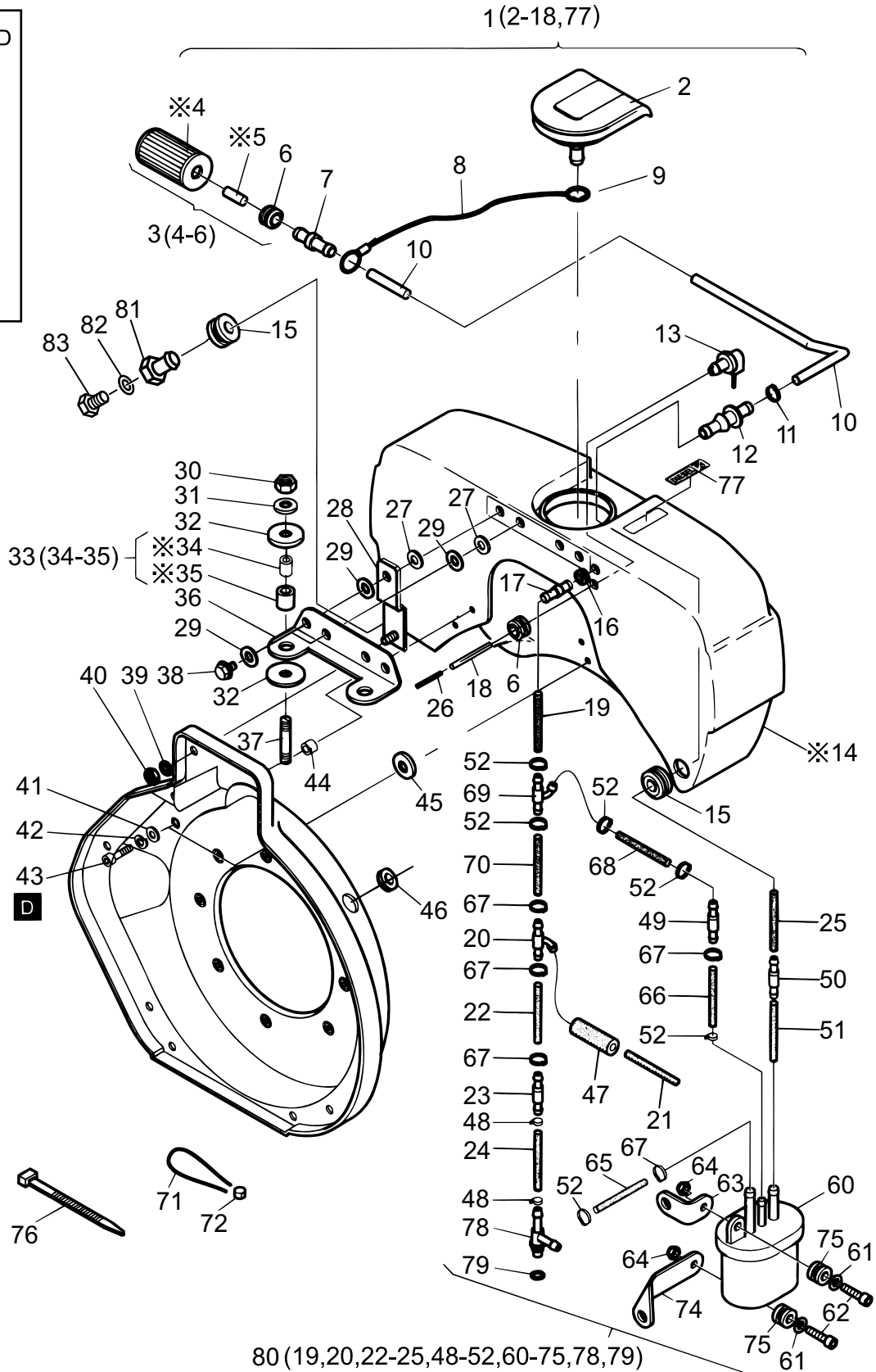
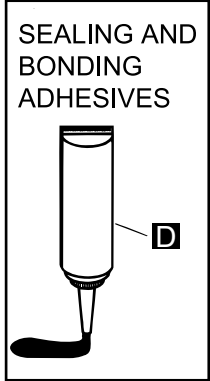

※ Parts not available separately

ROBIN D1B40T92040 — FUEL TANK ASSY.

<u>NO.</u>	<u>PART NO.</u>	<u>PART NAME</u>	<u>QTY.</u>	<u>REMARKS</u>
D	50223300	LOCTITE221 50ML	1	
1	01853200	FUEL TANK ASSY 5L F.SEP.	1	INCLUDES ITEMS W/ #
2#	01535302	CAP F. FUEL TANK	1	
3#	01635210	FUEL FILTER ASSY.	1	INCLUDES ITEMS W/ \$
4#\$		FUEL FILTER.....	1	NOT SOLD SEPARATELY
5#\$		SPACER.....	1	NOT SOLD SEPARATELY
6#\$	50440901	RUBBER SLEEVE	2	
7#	05189001	CONNECTING NIPPLE	1	
8#	01628900	ROPE	1	
9#	50500800	CIRCLIP 8	1	
10#	05160700	FUEL HOSE 3.5X340	1	
11#	50399801	CLAMP 11.3	1	
12#	05084010	CONNECTING NIPPLE	1	
13#	01534900	FUEL VENT. VALVE	1	
14#		FUEL TANK.....	1	NOT SOLD SEPARATELY
15#	50440800	RUBBER SLEEVE	2	
16#	05130400	RUBBER SLEEVE	1	
17#	05184400	CONNECTING NIPPLE	1	
18#	05189700	BREATHER HOSE	1	
19%	05289300	FUEL HOSE 5.0X50	1	
20%	05175601	HOSE NIPPLE T	1	
21	05215000	HOSE 2.5X195	1	
22%	03664210	HOSE 5X130	1	
23%	01534601	FUEL VENTG. VALVE	1	
24%	05214800	FUEL HOSE 4.5X40	1	
25%	05284010	FUEL HOSE 3.5X160	1	
26	05190900	TUBE	1	
27	50120000	DISC A 6.4	4	
28	01331300	SUPPORT	2	
29	05110010	DISC 7.1X17.9X2	10	
30	40028400	HEX NUT M 8	2	
31	50148100	FLAT WASHER 8.4	2	
32	05109810	DISC 8.2X22X2	4	
33	01655800	INSULATING TUBE	2	INCLUDES ITEMS W/ &
34&		INSULATING SLEEVE.....	1	NOT SOLD SEPARATELY
35&		RUBBER SHELL.....	1	NOT SOLD SEPARATELY
36	05170110	SUPPORT	1	
37	50231900	STUD M8X25	2	
38	01557000	HEXSCREW M6X16	4	
39	50170900	SPRING WASHER 6	2	
40	50144000	HEXSCREW M8X40	2	
41	50120000	DISC A6.4	4	
42	50170900	SPRING WASHER 6	4	
43	50170700	ALLEN SCREW M6X16	4	
44	04118800	DISC 6.5X13X4.8	2	
45	04042000	WASHER 6.5X22.5X1	2	

ROBIN D1B40T92040 — FUEL TANK ASSY. (CONTINUED)

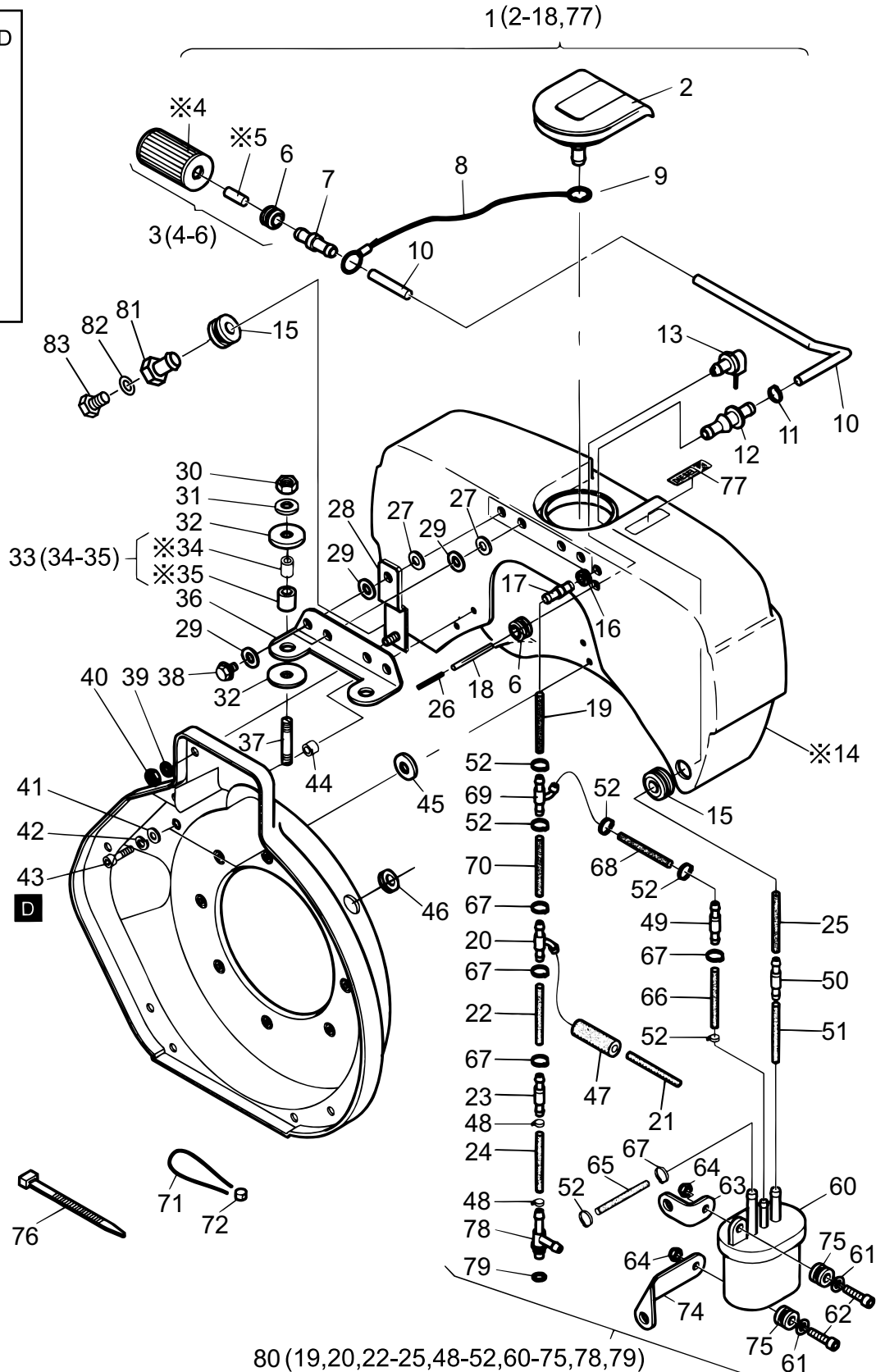
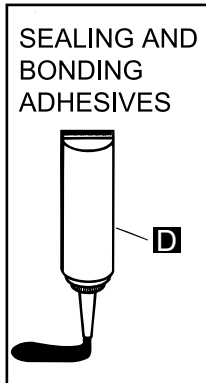

※ Parts not available separately

ROBIN D1B40T92040 — FUEL TANK ASSY. (CONTINUED)

<u>NO.</u>	<u>PART NO.</u>	<u>PART NAME</u>	<u>QTY.</u>	<u>REMARKS</u>
46	50453300	RUBBER SLEEVE	1	
47	05213010	FUEL HOSE 7X25	1	
48%	50441100	HOSE CLIP	2	
49%	00805502	VENT VALVE	1	
50%	05301200	NIPPLE	1	
51%	03663710	FUEL HOSE 5.0/50	1	
52%	50399801	CLAMP 11.3	6	
60%	50539200	FUEL FILT. EXT. MOUNT	1	
61%	50441600	WASHER 4.3	2	
62%	50446900	ALLEN SCREW M4X16	2	
63%	05279500	SUPPORT	1	
64%	50501600	HEX NUT M 4	2	
65%	03663610	FUEL HOSE 5X330	1	
66%	03663610	FUEL HOSE 5X330	1	
67%	50570900	CLAMP 12.8	5	
68%	05289300	FUEL HOSE 5.0X50	1	
69%	05122701	HOSE NIPPLE T	1	
70%	03663710	FUEL HOSE 5.0/50	1	
71%	40021500	SEAL WIRE 0.5-0.3	1	
72%	40021400	LEAD SEAL 8 MM	1	
74%	05285400	SUPPORT	1	
75%	50556600	RUBBER SLEEVE	2	
76	50358400	STRAP	2	
77#	05235601	STICKER,DIESEL FUEL	1	
78%	01756800	NIPPLE	1	
79%	50154300	O-RING 7.5X10.5X1.5	1	
80	01778520	FUEL FILTER CP. ASSY.	1	INCLUDES ITEMS W/ %
81	05235700	CONNECTING NIPPLE	1	
82	50313100	JOINT A 6X10	1	
83	03613600	VENT SCREW M6	1	

ROBIN D1B40T92040 — AIR FILTER ASSY.

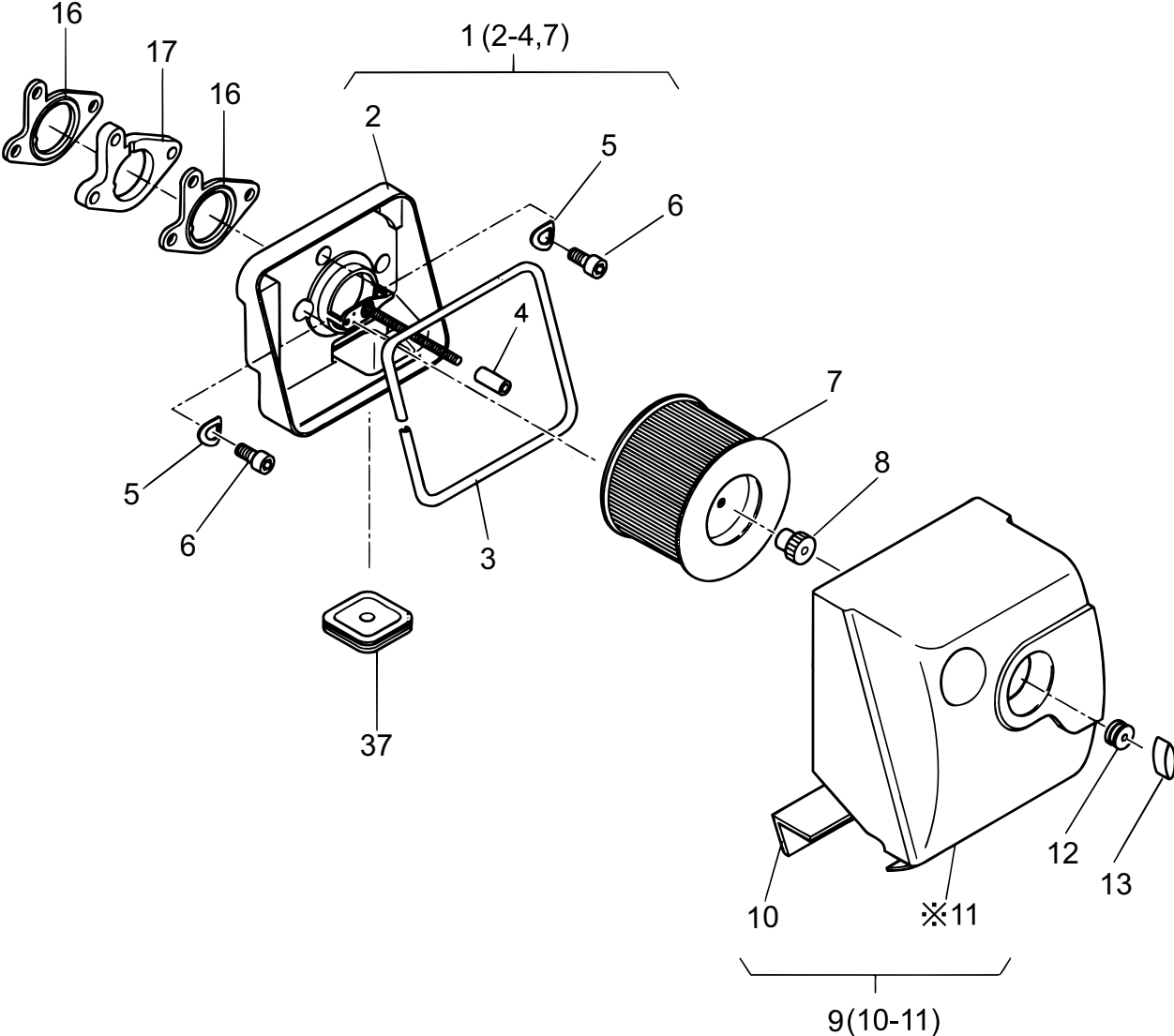

※ Part not available separately

ROBIN D1B40T92040 — AIR FILTER ASSY.

<u>NO.</u>	<u>PART NO.</u>	<u>PART NAME</u>	<u>QTY.</u>	<u>REMARKS</u>
1	01637410	AIR FILTER HOUSING ASSY.....	1.....	INCLUDES ITEMS W/ #
2#		AIR FILTER HOUSING	1.....	NOT AVAILABLE SEPARATELY
3#	05167700	SEALING STRIP 665MM	1	
4#	05166200	RUBBER SHELL 32MM	1	
5	50095100	SPRING WASHER A8	3	
6	50171500	ALLEN SCREW M 8X 25	3	
7#	50484100	AIR FILTER ELEMENT	1	
8	50454300	KNURLED NUT M6	1	
9	01637300	COVER ASSY, AIR FILTER	1.....	INCLUDES ITEMS W/ \$
10\$	05158000	SEALING STRIP	1	
11\$		COVER, AIR FILTER	1.....	NOT AVAILABLE SEPARATELY
12	50435800	RUBBER SLEEVE	1	
13	50452200	WING NUT M6	1	
16	05149900	GASKET AIR FILTER	2	
17	05149800	INSULATING FLANGE	1	
37	04215300	CLOSING COVER	1	

ROBIN D1B40T92040 — EXHAUST SLICENCER ASSY.

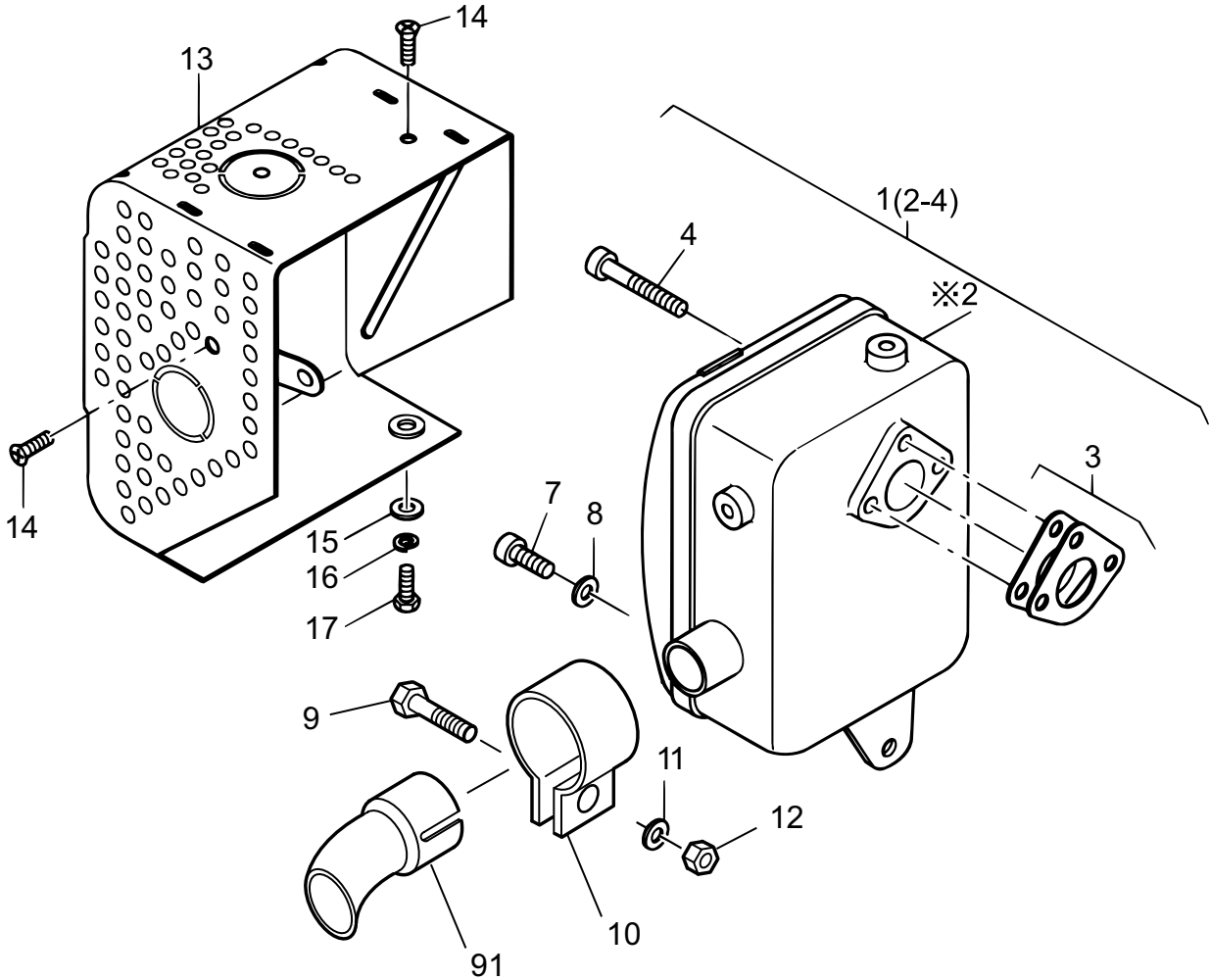

※ PARTS NOT AVAILABLE SEPARATELY

ROBIN D1B40T92040 — EXHAUST SILENCER ASSY.

<u>NO.</u>	<u>PART NO.</u>	<u>PART NAME</u>	<u>QTY.</u>	<u>REMARKS</u>
1	01872500	EXHAUST SILENCER ASSY.....	1.....	INCLUDES ITEMS W/ #
2#		EXHAUST SILENCER.....	1.....	NOT SOLD SEPARATELY
3#	01732701	GASKET MUFFLER	1	
4#	50403900	ALLEN SCREW M8X25	3	
7	50474200	ALLEN SCREW M6X16	1	
8	50114300	DISC 6.4	1	
9	00380000	HEX SCREW M8X50	1	
10	03740900	PIPE CLIP	1	
11	50148100	FLAT WASHER 8.4	1	
12	40028400	HEX NUT M8	1	
13	01629000	PROTECT.GUARD EXHAUST	1	
14	50422500	CTR. SUNK SCREW M6X12	2	
15	50114300	DISC 6.4	1	
16	50170900	SPRING WASHER 6	1	
17	50177100	HEX SCREW M6X16	1	
91	465459660	EXHAUST PIPE	1	

ROBIN D1B40T92040 — STARTER/REGULATOR ASSY.

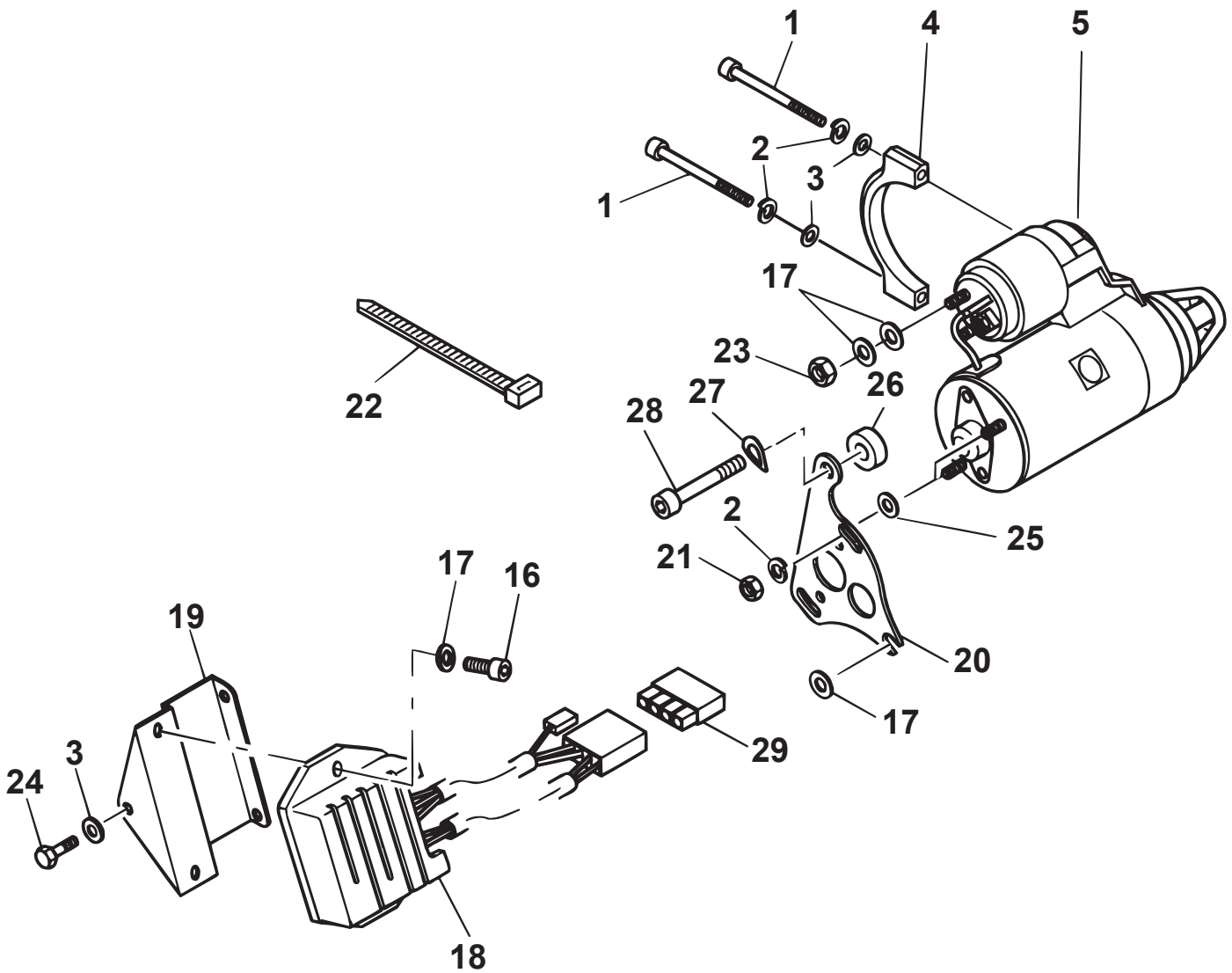

ROBIN D1B40T92040 — STARTER/REGULATOR ASSY.

<u>NO.</u>	<u>PART NO.</u>	<u>PART NAME</u>	<u>QTY.</u>	<u>REMARKS</u>
1	50402300	ALLEN SCREW M6X70	2	
2	50170900	SPRING WASHER 6	4	
3	50144500	FLAT WASHER 6.4	3	
4	04099100	RETAINING BRACKET	1	
5	50483500	STARTER12V 1.0KW	1	
16	50165400	ALLEN SCREW M8X16	2	
17	50148100	FLAT WASHER 8.4	6	
18	01983800	TENS. REGULATOR 12V	1	
19	01663000	SUPPORT	1	
20	05182912	SUPPORT	1	
21	50144400	HEXAGON NUT M6	2	
22	50439500	STRAP 2.6X200	3	
23	50344700	HEXAGON NUT M8	1	
24	50025400	HEX SCREW M6X10	1	
25	50120000	DISC A6.4	2	
26	03714100	SPACER BUSH	1	
27	50095100	SPRING WASHER A8	1	
28	50392900	ALLEN SCREW M8X50	1	
29	50402100	PLUG SLEEVE HOUSING	1	

ROBIN D1B40T92040 — ELECTRIC EQUIPMENT WIRING ASSY.

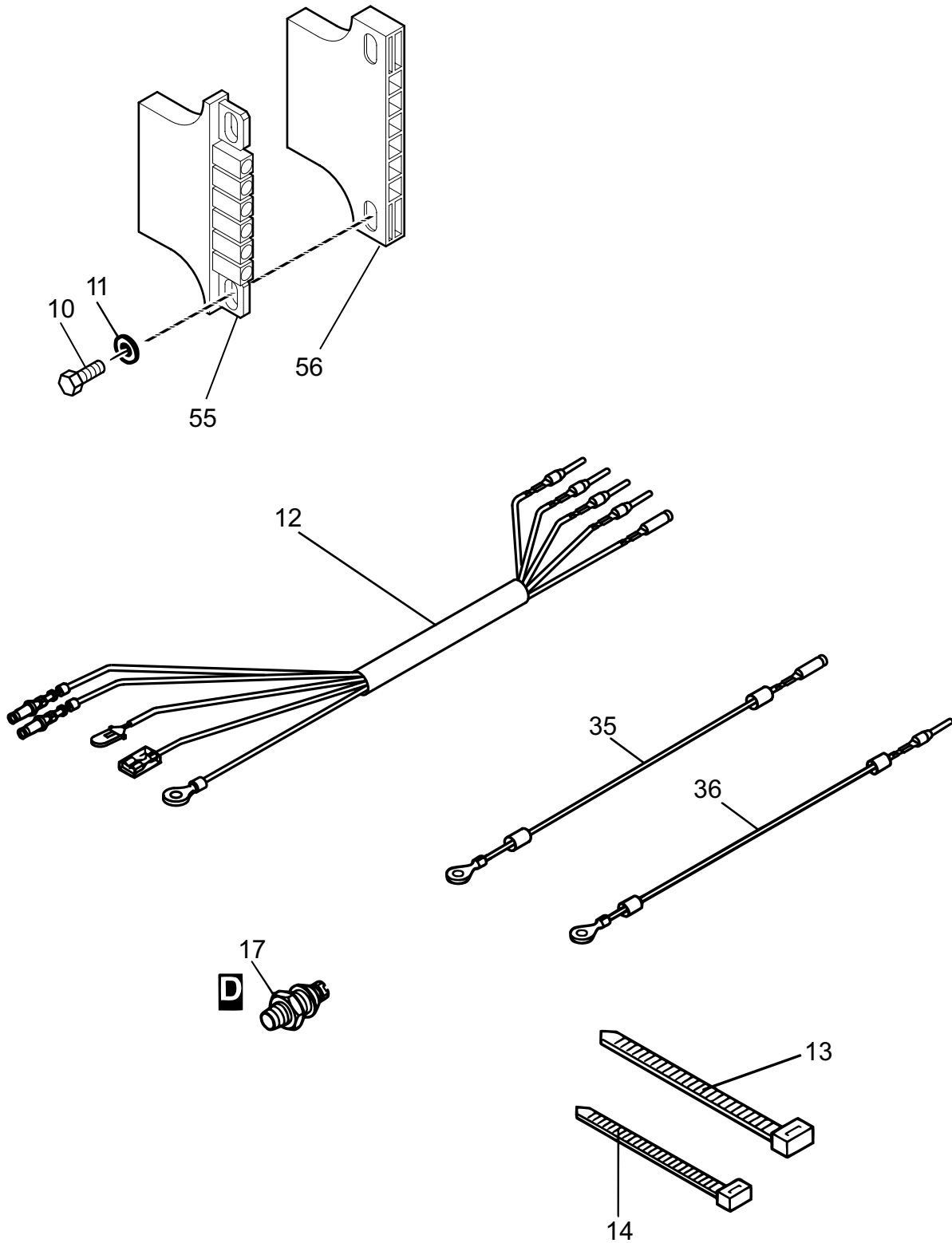

ROBIN D1B40T92040 — ELECTRIC EQUIPMENT WIRING ASSY.

<u>NO.</u>	<u>PART NO.</u>	<u>PART NAME</u>	<u>QTY.</u>	<u>REMARKS</u>
10	001220620	BOLT 6X20 T	2	
11	50144500	FLAT WASHER 6.4	2	
12	01667001	WIRE HARNESS	1	
13	50167400	STRAP	1	
14	50439500	STRAP 2.6X200	4	
17	50469100	OIL PRESSURE SWITCH	1	
35	01574300	ELECTRIC WIRE/350MM	1	
36	01715300	ELECTRIC WIRE/430MM	1	
55	50373700	PLUG SLEEVE HOUSING	1	
56	50373600	PIN TERM.HOUS.6WAY	1	

ROBIN D1B40T92040 — SPEED CONTROL ASSY.

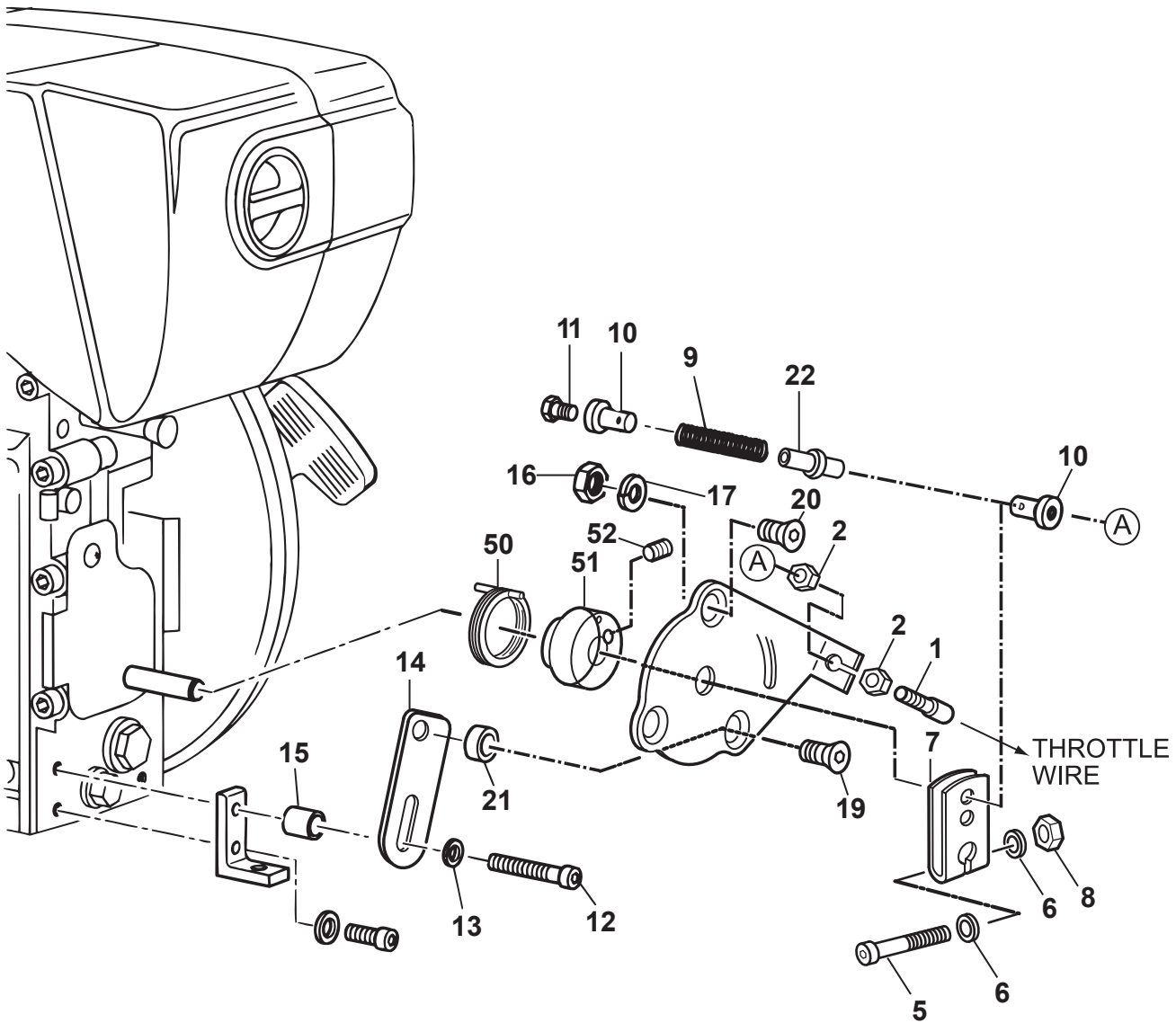

ROBIN D1B40T92040 — SPEED CONTROL ASSY.

<u>NO.</u>	<u>PART NO.</u>	<u>PART NAME</u>	<u>QTY.</u>	<u>REMARKS</u>
1	05141200	ADJUSTING SCREW	1	
2	020406040	NUT M6, H=4.2	2	
5	50511900	ALLEN SCREW M 5X30	1	
6	50216300	WASHER 5.3	2	
7	05117700	LEVER	1	
8	50094300	HEXAGON NUT M5	1	
9	50484600	PRESSURE SPRING	1	
10	50483100	CABLE CLAMP 2.2MM	2	
11	50025000	HEX SCREW M 4X10	1	
12	50342400	ALLEN SCREW M 8X50	1	
13	50148100	FLAT WASHER 8.4	1	
14	05189600	PLATE	1	
15	03599600	SPACER BUSH	1	
16	50328300	HEXAGON NUT VM6	1	
17	50208500	SPRING WASHER 8	1	
19	50423900	CTR.SUNK SCREW M6X20	1	
20	50380800	CTR.SUNK SCREW M6X10	1	
21	03292900	SPACER TUBE	1	
22	05165000	GUIDE BUSH	1	
50	05179100	SPRING	1	
51	05179000	BUSH	1	
52	50400600	GRUB SCREW M5X10	1	

TERMS AND CONDITIONS OF SALE — PARTS

PAYMENT TERMS

Terms of payment for parts are net 30 days.

FREIGHT POLICY

All parts orders will be shipped collect or prepaid with the charges added to the invoice. All shipments are F.O.B. point of origin. Multiquip's responsibility ceases when a signed manifest has been obtained from the carrier, and any claim for shortage or damage must be settled between the consignee and the carrier.

MINIMUM ORDER

The minimum charge for orders from Multiquip is \$15.00 net. Customers will be asked for instructions regarding handling of orders not meeting this requirement.

RETURNED GOODS POLICY

Return shipments will be accepted and credit will be allowed, subject to the following provisions:

1. A Returned Material Authorization must be approved by Multiquip prior to shipment.
2. To obtain a Return Material Authorization, a list must be provided to Multiquip Parts Sales that defines item numbers, quantities, and descriptions of the items to be returned.
 - a. The parts numbers and descriptions must match the current parts price list.
 - b. The list must be typed or computer generated.
 - c. The list must state the reason(s) for the return.
 - d. The list must reference the sales order(s) or invoice(s) under which the items were originally purchased.
 - e. The list must include the name and phone number of the person requesting the RMA.
3. A copy of the Return Material Authorization must accompany the return shipment.
4. Freight is at the sender's expense. All parts must be returned freight prepaid to Multiquip's designated receiving point.

5. Parts must be in new and resalable condition, in the original Multiquip package (if any), and with Multiquip part numbers clearly marked.
6. The following items are not returnable:
 - a. Obsolete parts. (If an item is in the price book and shows as being replaced by another item, it is obsolete.)
 - b. Any parts with a limited shelf life (such as gaskets, seals, "O" rings, and other rubber parts) that were purchased more than six months prior to the return date.
 - c. Any line item with an extended dealer net price of less than \$5.00.
 - d. Special order items.
 - e. Electrical components.
 - f. Paint, chemicals, and lubricants.
 - g. Decals and paper products.
 - h. Items purchased in kits.
7. The sender will be notified of any material received that is not acceptable.
8. Such material will be held for five working days from notification, pending instructions. If a reply is not received within five days, the material will be returned to the sender at his expense.
9. Credit on returned parts will be issued at dealer net price at time of the original purchase, less a 15% restocking charge.
10. In cases where an item is accepted, for which the original purchase document can not be determined, the price will be based on the list price that was effective twelve months prior to the RMA date.
11. Credit issued will be applied to future purchases only.

PRICING AND REBATES

Prices are subject to change without prior notice. Price changes are effective on a specific date and all orders received on or after that date will be billed at the revised price. Rebates for price declines and added charges for price increases will not be made for stock on hand at the time of any price change.

Multiquip reserves the right to quote and sell direct to Government agencies, and to Original Equipment Manufacturer accounts who use our products as integral parts of their own products.

SPECIAL EXPEDITING SERVICE

A \$35.00 surcharge will be added to the invoice for special handling including bus shipments, insured parcel post or in cases where Multiquip must personally deliver the parts to the carrier.

LIMITATIONS OF SELLER'S LIABILITY

Multiquip shall not be liable hereunder for damages in excess of the purchase price of the item with respect to which damages are claimed, and in no event shall Multiquip be liable for loss of profit or good will or for any other special, consequential or incidental damages.

LIMITATION OF WARRANTIES

No warranties, express or implied, are made in connection with the sale of parts or trade accessories nor as to any engine not manufactured by Multiquip. Such warranties made in connection with the sale of new, complete units are made exclusively by a statement of warranty packaged with such units, and Multiquip neither assumes nor authorizes any person to assume for it any other obligation or liability whatever in connection with the sale of its products. Apart from such written statement of warranty, there are no warranties, express, implied or statutory, which extend beyond the description of the products on the face hereof.

Effective: February 22, 2006

OPERATION AND PARTS MANUAL

HERE'S HOW TO GET HELP

PLEASE HAVE THE MODEL AND SERIAL
NUMBER ON-HAND WHEN CALLING

UNITED STATES

Multiquip Corporate Office

18910 Wilmington Ave. Tel. (800) 421-1244
Carson, CA 90746 Fax (310) 537-3927
Contact: mq@multiquip.com

Service Department

800-421-1244 Fax: 310-537-4259
310-537-3700

Technical Assistance

800-478-1244 Fax: 310-943-2238

MQ Parts Department

800-427-1244 Fax: 800-672-7877
310-537-3700 Fax: 310-637-3284

Warranty Department

800-421-1244 Fax: 310-943-2249
310-537-3700

CANADA

Multiquip

4110 Industriel Boul. Tel: (450) 625-2244
Laval, Quebec, Canada H7L 6V3 Tel: (877) 963-4411
Contact: jmartin@multiquip.com Fax: (450) 625-8664

UNITED KINGDOM

Multiquip (UK) Limited Head Office

Unit 2, Northpoint Industrial Estate, Tel: 0161 339 2223
Globe Lane, Fax: 0161 339 3226
Dukinfield, Cheshire SK16 4UJ
Contact: sales@multiquip.co.uk

© COPYRIGHT 2014, MULTIQUIP INC.

Multiquip Inc, the MQ logo are registered trademarks of Multiquip Inc. and may not be used, reproduced, or altered without written permission. All other trademarks are the property of their respective owners and used with permission.

This manual MUST accompany the equipment at all times. This manual is considered a permanent part of the equipment and should remain with the unit if resold.

The information and specifications included in this publication were in effect at the time of approval for printing. Illustrations, descriptions, references and technical data contained in this manual are for guidance only and may not be considered as binding. Multiquip Inc. reserves the right to discontinue or change specifications, design or the information published in this publication at any time without notice and without incurring any obligations.

Your Local Dealer is:



Free Manuals Download Website

<http://myh66.com>

<http://usermanuals.us>

<http://www.somanuals.com>

<http://www.4manuals.cc>

<http://www.manual-lib.com>

<http://www.404manual.com>

<http://www.luxmanual.com>

<http://aubethermostatmanual.com>

Golf course search by state

<http://golfingnear.com>

Email search by domain

<http://emailbydomain.com>

Auto manuals search

<http://auto.somanuals.com>

TV manuals search

<http://tv.somanuals.com>