

# OPERATION AND PARTS MANUAL



*Mikasa* **SERIES**  
**MODEL MTX60HF**  
**TAMPING RAMMER**  
**(HONDA GX100UKRB5 GASOLINE ENGINE)**

Revision #0 (12/22/11)

To find the latest revision of this  
publication, visit our website at:  
[www.multiquip.com](http://www.multiquip.com)



**THIS MANUAL MUST ACCOMPANY THE EQUIPMENT AT ALL TIMES.**



**CALIFORNIA — Proposition 65 Warning**

Gasoline engine exhaust and some of its constituents are known to the State of California to cause cancer, birth defects and other reproductive harm.



# TABLE OF CONTENTS

## MTX60HF Rammer

Proposition 65 Warning .....	2
Parts Ordering Procedures.....	5
Safety Information .....	6-9
Specifications .....	10
General Information.....	11
Components .....	12
Basic Engine.....	13
Inspection .....	14
Operation.....	15-16
Maintenance .....	17
Troubleshooting .....	18-20
Explanation Of Code In Remarks Column.....	22
Suggested Spare Parts .....	23

## Component Drawings

Nameplates And Decals .....	24-25
Crankcase And Engine Assy .....	26-29
Guide Cylinder Assy .....	30-31
Foot Assy.....	32-33
Fuel Tank And Handle Assy.....	34-35
Combination Lever Assy.....	36-37

## Honda GX100UKRB5 Engine

Cylinder Barrel Assy.....	38-39
Crankcase Cover Assy.....	40-41
Crankshaft Assy.....	42-43
Piston/Conn. Rod Assy. ....	44-45
Camshaft Assy.....	46-47
Carburetor Assy. ....	52-53
Air Cleaner Assy. ....	54-55
Muffler Assy. ....	56-57
Flywheel Ignition Assy.....	58-59
Control Assy.....	60-61
Labels Assy.....	62-63
Terms And Conditions Of Sale — Parts .....	64

### NOTICE

Specifications and part numbers are subject to change without notice.

# PARTS ORDERING PROCEDURES

## Ordering parts has never been easier! Choose from three easy options:

Effective:  
January 1<sup>st</sup>, 2006

www.multiquip.com



### Order via Internet (Dealers Only):

Order parts on-line using Multiquip's SmartEquip website!

- View Parts Diagrams
- Order Parts
- Print Specification Information



If you have an MQ Account, to obtain a Username and Password, E-mail us at: [parts@multiquip.com](mailto:parts@multiquip.com).

To obtain an MQ Account, contact your District Sales Manager for more information.

Goto [www.multiquip.com](http://www.multiquip.com) and click on **Order Parts** to log in and save!

Use the **internet** and qualify for a **5% Discount** on *Standard orders* for all orders which include complete part numbers.\*

Note: Discounts Are Subject To Change

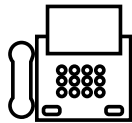

### Order via Fax (Dealers Only):

All customers are welcome to order parts via Fax.

**Domestic (US) Customers dial:**  
1-800-6-PARTS-7 (800-672-7877)

**Fax** your order in and qualify for a **2% Discount** on *Standard orders* for all orders which include complete part numbers.\*

Note: Discounts Are Subject To Change



**Order via Phone: Domestic (US) Dealers Call:**  
1-800-427-1244

### Non-Dealer Customers:

Contact your local Multiquip Dealer for parts or call 800-427-1244 for help in locating a dealer near you.



**International Customers** should contact their local Multiquip Representatives for Parts Ordering information.

## When ordering parts, please supply:

- |                                                                               |                                                                                        |
|-------------------------------------------------------------------------------|----------------------------------------------------------------------------------------|
| <input type="checkbox"/> Dealer Account Number                                | <input type="checkbox"/> Specify Preferred Method of Shipment:                         |
| <input type="checkbox"/> Dealer Name and Address                              | <input checked="" type="checkbox"/> UPS/Fed Ex <input checked="" type="checkbox"/> DHL |
| <input type="checkbox"/> Shipping Address (if different than billing address) | <input type="checkbox"/> Priority One <input checked="" type="checkbox"/> Truck        |
| <input type="checkbox"/> Return Fax Number                                    | <input type="checkbox"/> Ground                                                        |
| <input type="checkbox"/> Applicable Model Number                              | <input type="checkbox"/> Next Day                                                      |
| <input type="checkbox"/> Quantity, Part Number and Description of Each Part   | <input type="checkbox"/> Second/Third Day                                              |

### NOTICE

All orders are treated as *Standard Orders* and will ship the same day if received prior to 3PM PST.

WE ACCEPT ALL MAJOR CREDIT CARDS!



# SAFETY INFORMATION

Do not operate or service the equipment before reading the entire manual. Safety precautions should be followed at all times when operating this equipment. Failure to read and understand the safety messages and operating instructions could result in injury to yourself and others.



## SAFETY MESSAGES

The four safety messages shown below will inform you about potential hazards that could injure you or others. The safety messages specifically address the level of exposure to the operator and are preceded by one of four words: **DANGER**, **WARNING**, **CAUTION** or **NOTICE**.

## SAFETY SYMBOLS

**! DANGER**

Indicates a hazardous situation which, if not avoided, **WILL** result in **DEATH** or **SERIOUS INJURY**.

**! WARNING**

Indicates a hazardous situation which, if not avoided, **COULD** result in **DEATH** or **SERIOUS INJURY**.







**! CAUTION**

Indicates a hazardous situation which, if not avoided, **COULD** result in **MINOR** or **MODERATE INJURY**.

**NOTICE**

Addresses practices not related to personal injury.

Potential hazards associated with the operation of this equipment will be referenced with hazard symbols which may appear throughout this manual in conjunction with safety messages.

Symbol	Safety Hazard
	Lethal exhaust gas hazards
	Explosive fuel hazards
	Burn hazards
	Respiratory hazards
	Accidental starting hazards
	Eye and hearing hazards

# SAFETY INFORMATION

## GENERAL SAFETY

### CAUTION

- **NEVER** operate this equipment without proper protective clothing, shatterproof glasses, respiratory protection, hearing protection, steel-toed boots and other protective devices required by the job or city and state regulations.



- **NEVER** operate this equipment when not feeling well due to fatigue, illness or when under medication.



- **NEVER** operate this equipment under the influence of drugs or alcohol.



- **ALWAYS** check the equipment for loosened threads or bolts before starting.
- **DO NOT** use the equipment for any purpose other than its intended purposes or applications.

### NOTICE

- This equipment should only be operated by trained and qualified personnel 18 years of age and older.
- Whenever necessary, replace nameplate, operation and safety decals when they become difficult read.
- Manufacturer does not assume responsibility for any accident due to equipment modifications. Unauthorized equipment modification will void all warranties.
- **NEVER** use accessories or attachments that are not recommended by Multiquip for this equipment. Damage to the equipment and/or injury to user may result.
- **ALWAYS** know the location of the nearest fire extinguisher.
- **ALWAYS** know the location of the nearest first aid kit.



- **ALWAYS** know the location of the nearest phone or **keep a phone on the job site**. Also, know the phone numbers of the nearest **ambulance, doctor** and **fire department**. This information will be invaluable in the case of an emergency.

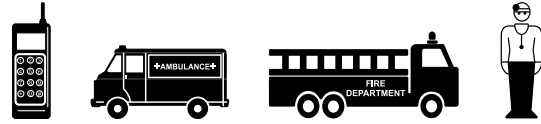

## RAMMER SAFETY

### DANGER

- **NEVER** operate the equipment in an explosive atmosphere or near combustible materials. An explosion or fire could result causing severe **bodily harm or even death**.



### WARNING

- **NEVER** disconnect any **emergency or safety devices**. These devices are intended for operator safety. Disconnection of these devices can cause severe injury, bodily harm or even death. Disconnection of any of these devices will void all warranties.
- **DO NOT** use this machine on ground that is harder than the machine can handle, or for driving pilings or tamping rock beds. Furthermore, use of the machine on sloping ground, such as the side of an embankment, may make the machine unstable and can cause an accident. It can also result in premature machine wear due to uneven loads on the machine.

Use the machine with confidence for tamping earth and sand, soil, gravel, and asphalt. **DO NOT** use the machine for other types of jobs.

### CAUTION

- **NEVER** lubricate components or attempt service on a running machine.

### NOTICE

- **ALWAYS** keep the machine in proper running condition.
- Fix damage to machine and replace any broken parts immediately.
- **ALWAYS** store equipment properly when it is not being used. Equipment should be stored in a clean, dry location out of the reach of children and unauthorized personnel.

# SAFETY INFORMATION

## ENGINE SAFETY

### DANGER

- The engine fuel exhaust gases contain poisonous carbon monoxide. This gas is colorless and odorless, and can cause death if inhaled.
- The engine of this equipment requires an adequate free flow of cooling air. **NEVER** operate this equipment in any enclosed or narrow area where free flow of the air is restricted. If the air flow is restricted it will cause injury to people and property and serious damage to the equipment or engine.



### WARNING

- **DO NOT** place hands or fingers inside engine compartment when engine is running.
- **NEVER** operate the engine with heat shields or guards removed.
- **DO NOT** remove the engine oil drain plug while the engine is hot. Hot oil will gush out of the oil tank and severely scald any persons in the general area of the rammer.



### CAUTION

- **NEVER** touch the hot exhaust manifold, muffler or cylinder. Allow these parts to cool before servicing equipment.



### NOTICE

- **NEVER** run engine without an air filter or with a dirty air filter. Severe engine damage may occur. Service air filter frequently to prevent engine malfunction.
- **NEVER** tamper with the factory settings of the engine or engine governor. Damage to the engine or equipment can result if operating in speed ranges above the maximum allowable.



## FUEL SAFETY

### DANGER

- **DO NOT** add fuel to equipment if it is placed inside truck bed with plastic liner. Possibility exists of explosion or fire due to static electricity.

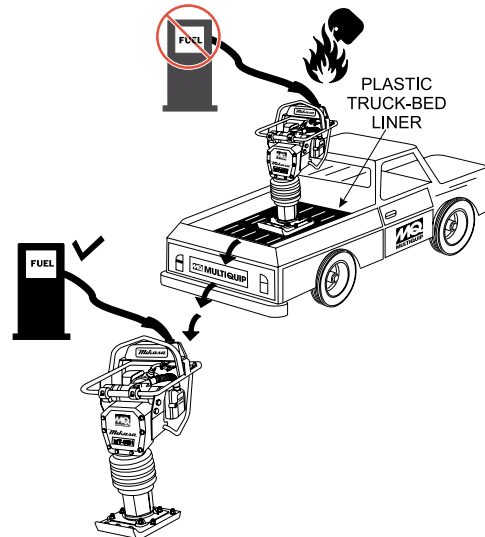

- **DO NOT** start the engine near spilled fuel or combustible fluids. Fuel is extremely flammable and its vapors can cause an explosion if ignited.
- **ALWAYS** refuel in a well-ventilated area, away from sparks and open flames.
- **ALWAYS** use extreme caution when working with **flammable** liquids.
- **DO NOT** fill the fuel tank while the engine is running or hot.
- **DO NOT** overfill tank, since spilled fuel could ignite if it comes into contact with hot engine parts or sparks from the ignition system.
- Store fuel in appropriate containers, in well-ventilated areas and away from sparks and flames.
- **NEVER** use fuel as a cleaning agent.
- **DO NOT** smoke around or near the equipment. Fire or explosion could result from fuel vapors or if fuel is spilled on a hot engine.





## TRANSPORTING SAFETY

### CAUTION

- NEVER allow any person or animal to stand underneath the equipment while lifting.

### NOTICE

- Before lifting, make sure that the equipment parts (hook and vibration insulator) are not damaged and screws are not loose or missing.
- Always make sure crane or lifting device has been properly secured to the lifting bail (hook) of the equipment.
- **ALWAYS** shutdown engine before transporting.
- **NEVER** lift the equipment while the engine is running.
- Tighten fuel tank cap securely and close fuel cock to prevent fuel from spilling.
- Use adequate lifting cable (wire or rope) of sufficient strength.
- Use one point suspension hook and lift straight upwards.
- **DO NOT** lift machine to unnecessary heights.
- **ALWAYS** tie down equipment during transport by securing the equipment with rope.
- Never allow any person or animal to stand underneath the equipment while lifting.

## ENVIRONMENTAL SAFETY

### NOTICE

- Dispose of hazardous waste properly. Examples of potentially hazardous waste are used motor oil, fuel and fuel filters. 
- **DO NOT** use food or plastic containers to dispose of hazardous waste.
- **DO NOT** pour waste, oil or fuel directly onto the ground, down a drain or into any water source.

# SPECIFICATIONS

**Table 1. Rammer Specifications**

Overall Height	38.8 in. (985 mm)
Overall Width	13.8 in. (350 mm)
Over Length	28.1 in. (713 mm)
Shoe Size (W x L)	10.4 x 13.4 in. (265 x 340 mm)
Fuel Tank Capacity	2.1 qt. (2 liters)
Lubrication Oil Capacity	0.69 qt. (0.65 liter)
No. of Blows	644 - 695 vpm (10.7 - 11.6 Hz)
Impact Force	3,060 lbf (13.6 kN)
Impact Plate Stroke	2 - 3.2 in. (50 - 80 mm)
Operating Weight	141 lbs. (64 kg)
Measured Sound Power Level	103 dB
Guaranteed Sound Power Level	107 dB
Max. Sound Pressure Level	92 dB

**Table 2. Engine Specifications**

Model	Honda GX100UKRB5 Engine
Type	Air-Cooled 4 Stroke, Overhead camshaft, single cylinder gasoline engine
Piston Displacement	6.0 cu.in. (98 cc)
Max. Output	3.0 hp/3,600 rpm (2.2 KW)
Max. Governed Speed, No Load	3,800 - 4,100 rpm
Cooling System	Air-Cooled
Engine Oil Capacity	0.3 qt. (0.28 liters)
Fuel	Unleaded gasoline
Lubricant for Engine	Automobile Oil; Class SE or higher
Starting System	Recoil Starter
Spark Plug Type	NGK CR5HSB

## DEFINITION OF TAMPING RAMMER

The Multiquip MTX60HF tamping rammer is a powerful compacting tool capable of applying a tremendous force in consecutive impacts to a soil surface. Its applications include soil compacting for road, embankments and reservoirs as well as backfilling for gas pipelines, water pipelines and cable installation work.

The impact force of the MTX60HF levels and uniformly compacts voids between soil particles to increase dry density.

Circular motion is converted to create impact force. The MTX60HF tamping rammer develops a powerful compacting force at the foot of the rammer. To maintain optimum performance, proper operation and service are essential.

## CONSTRUCTION OF TAMPING RAMMER

The MTX60HF is equipped with an air cooled, four-cycle gasoline engine. Transmission of the power takes place by increasing the engine speed to engage the centrifugal clutch.

## RAMMER GEARBOX AND SPRING CYLINDER

The MTX60HF uses an oil bath lubrication system. Always check the oil level through the oil level sight glass at the rear of the tamper foot.

## CONTROLS

Before starting the MTX60HF Tamping Rammer identify and understand the function of the controls.

### CAUTION



Before starting operation check the lifting handle to:

1. Make sure that there is no damage on the bolts.
2. Make sure that there is no crack or breakage on handle.
3. Make sure that there is no fissure on the surface. If there is any abnormality or damage, replace with new one.

For operation:

This handle is to be used to lift up the shoe part of the machine with the body laid down on the ground or truck bed.

1. Use proper lifting techniques to avoid back injury. This handle is for manual lifting only.
2. Do not use this handle as a rammer lift point. Use the lifting point on the top of the machine.
3. Do not move the rammer with the lifting handle and the front rollers more than 16 feet (5 meters).

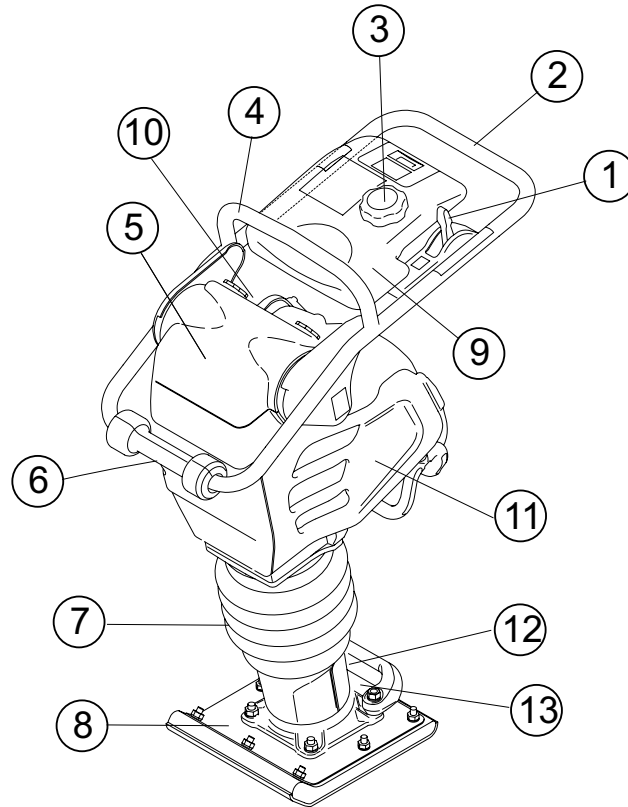

**Figure 1. MTX60HF Rammer**

Figure 1 shows the location of the controls and components for the MTX60HF Tamping Rammer. The functions of each control is described below:

1. **Combination (Throttle) Lever** — Used to adjust engine speed (rpm). Move lever forward (**SLOW**) to reduce engine speed, move lever back toward operator (**FAST**) to increase speed. Always operate the rammer at full speed (rpm).
2. **Handle** — To operate rammer, **GRIP** handle assembly firmly on both sides.
3. **Fuel Tank Cap** — Remove this cap to add unleaded gasoline to the fuel tank. Make sure cap is tightened securely. **DO NOT** over fill.
4. **Hook** — Used to lift rammer for transporting.
5. **Air Cleaner Cover** — Protects the air cleaner which prevents dirt and other debris from entering the engine.
6. **Roller** — Allows rammer to be moved around easily by rolling the unit.
7. **Bellows** — Reservoir for oil bath.
8. **Foot** — Laminated wood with tempered steel plate for superior shock absorption.
9. **Fuel Tank** — Holds the fuel for the unit (up to 3.2 quarts).
10. **Muffler** — reduces the noise of the engine when running.
11. **Engine** — this unit uses a Honda GX100UKRB5 gasoline engine.
12. **Oil Gauge (Sight Glass)** — Indicates the level of oil in the oil bath reservoir.
13. **Drain Valve** — Open this valve to remove oil from the bellows.

**WARNING**



Adding fuel to the tank should be accomplished only when the engine is stopped and has had an opportunity to cool down. In the event of a fuel spill, **DO NOT** attempt to start the engine until the fuel residue has been completely wiped up, and the area surrounding the engine is dry.

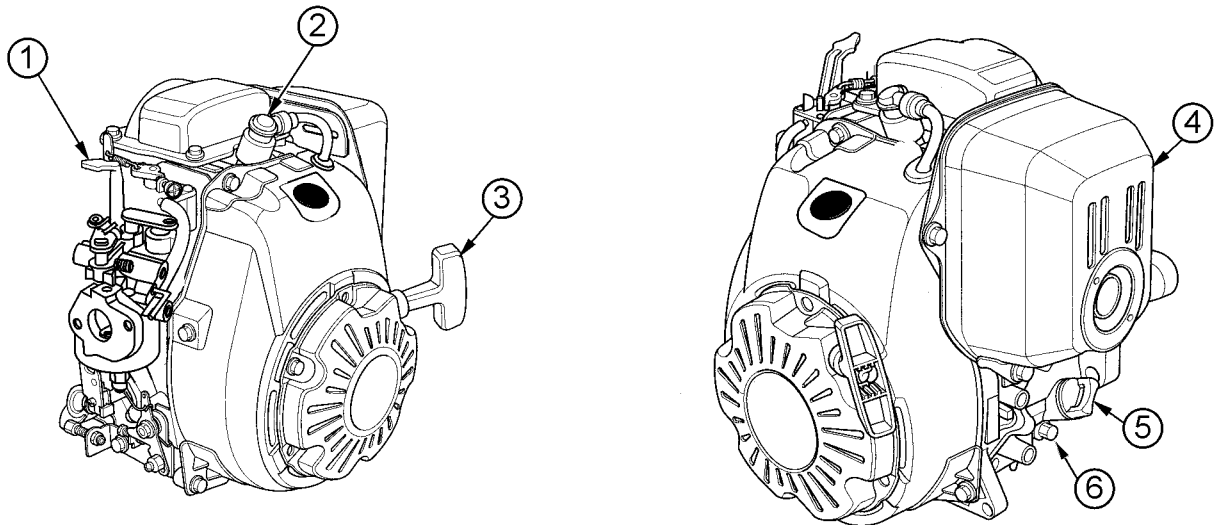

**Figure 2. Honda GX100 Engine**

The engine (Figure 2) must be checked for proper lubrication and filled with fuel prior to operation. Refer to the engine manufacturer's manual for detailed operation and service information.

1. **Choke Lever** — Normally used in starting the engine in cold weather conditions. In cold weather, turn the choke lever to the fully closed position. In warm weather, set the choke lever halfway or completely open.
2. **Spark Plug** — Provides spark to the ignition system. Set spark plug gap to 0.024 - 0.028 inch (0.6 - 0.7 mm). Clean spark plug once a week.
3. **Recoil Starter (pull rope)** — Manual-starting method. Pull the starter grip until resistance is felt, then pull briskly and smoothly.

## NOTICE

Operating the engine without an air filter, with a damaged air filter, or a filter in need of replacement will allow dirt to enter the engine, causing rapid engine wear.

4. **Muffler** — Used to reduce noise and emissions.
5. **Dipstick/Oil Filler Cap** — Remove this cap to determine if the engine oil is low. Add oil through this filler port as recommended in Table 3.
6. **Oil Drain Plug** — Remove this plug to remove oil from the engine's crankcase.

## WARNING



Engine components can generate extreme heat. To prevent burns, **DO NOT** touch these areas while the engine is running or immediately after operating. **NEVER** operate the engine with the muffler removed.

It is extremely important that this section be read carefully before attempting to operate the rammer. **DO NOT** use your rammer until this section is thoroughly understood.

## CRANKCASE AND SPRING CYLINDER OIL BATH

This unit uses an oil bath lubrication system. Perform the following:

1. Check the oil level through the oil level sight glass (Figure 3) at the rear of the tamper foot.

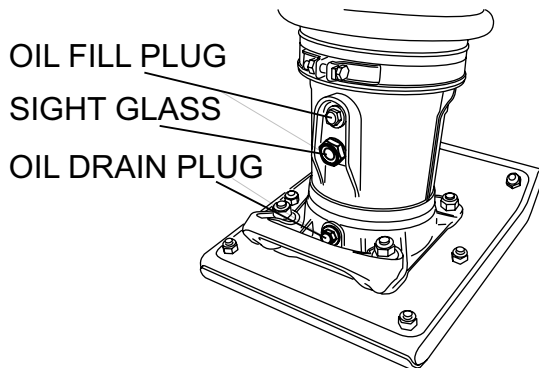

**Figure 3. Foot Housing Sight Glass**

### NOTICE

The oil level should be kept at the half way point of the sight glass.

2. If oil is not visible, add 10W-30 SE, SF or higher grade motor oil into the oil fill plug opening (Figure 3). The bath contains approximately 1.3 pints (650 cc.)

## ENGINE

1. Fill the fuel tank (Figure 4) with unleaded gasoline. At the same time, check the engine oil and make it a habit to replenish it often (Figure 5).

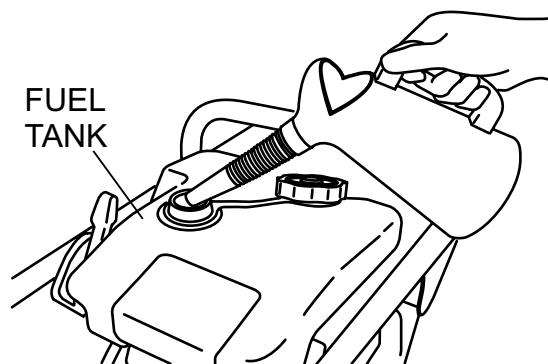

**Figure 4. Fuel Tank**

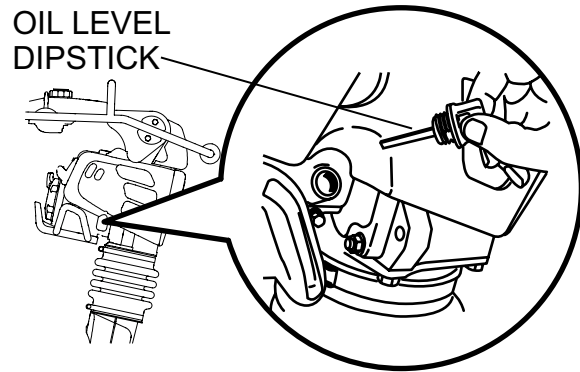

**Figure 5. Engine Oil Dipstick**

2. Low levels of oil may result in engine seizure due to high levels of consumption during operation.
3. Check the engine oil level and if the engine oil level is low, it should be refilled. Use the proper motor oil as suggested in the Table 3 below.

**Table 3. Motor Oil Grade**

Season or Temperature	Grade of motor oil (higher than MS class)
Spring, Summer or Autumn +120° F to +15° F	SAE 30
Winter +40° F to +15° F	SAE 30
Below +15° F	SAE 10W-30

## GENERAL INSPECTION

1. Check all nuts, bolts fasteners for tightness. Retighten as necessary.
2. Clean any dirt from the recoil starter and foot pedestal. Wipe the entire unit clean before operating.
3. Replace any missing or damaged Safety Operation decals.
4. Adjust height of handle. Adjust handle by loosening nuts and moving handle to suit operation. Retighten nuts.

## **CAUTION**

Failure to understand the operation of the Tamping Rammer could result in severe damage to the unit or personal injury.

### INITIAL STARTUP

When starting the MTX60HF Tamping Rammer perform the following:

1. Slide the throttle lever from the stop to the idle position (☛) (Figure 6). This opens the fuel cock and the engine electrical circuit is turned on automatically.

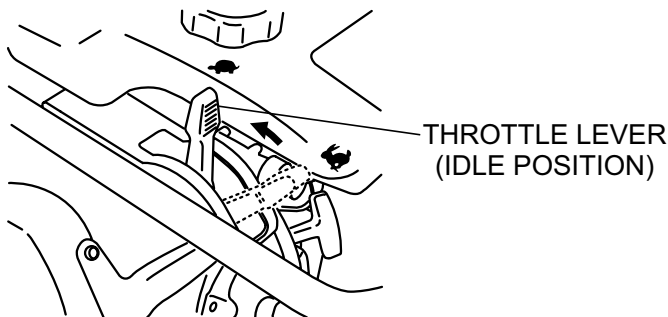

**Figure 6. Throttle Lever (Idle Position)**

2. Place the choke lever to the closed position. When the weather is cold, close the choke all the way. When it is hot, or if the engine is hot, open the choke a little or leave it fully open (Figure 7).

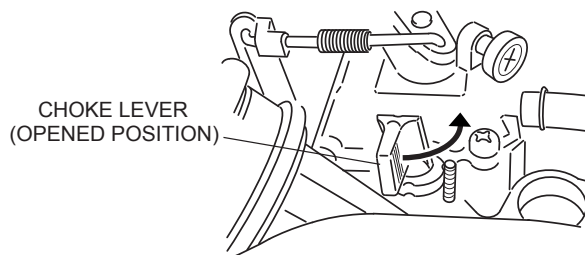

**Figure 7. Choke Lever**

3. Grip the starter rope handle (Figure 8) and pull it until you feel a slight resistance. Then pull sharply and quickly. Return the handle to the starter case before releasing.

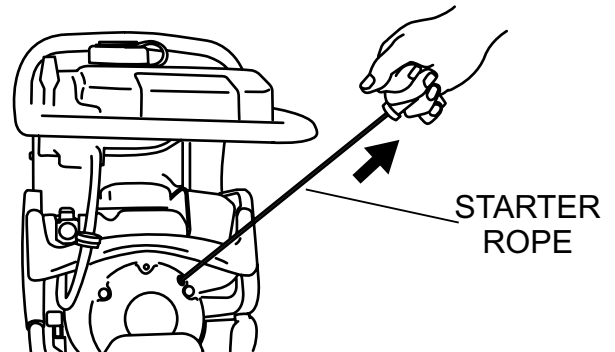

**Figure 8. Recoil Starter**

4. If engine fails to start, move the choke lever (Figure 7) to the half open position to avoid flooding.
5. Repeat steps 1 thru 4.
6. If the engine does not start after repeated attempts, do the following:
  - a. Check fuel delivery from fuel tank to carburetor.
  - b. Check for restrictions to fuel flow at in-tank filter.
  - c. Check for restrictions to fuel flow at in-line filter.
  - d. Inspect spark plug for contamination and proper gap. Clean, adjust or replace spark plug as required.

## OPERATION

1. To start the rammer tamping action, move the throttle lever (Figure 9) **quickly** from **IDLE** to the **START** (👉) position. **DO NOT** move the throttle lever slowly as this may cause damage to the clutch or spring.

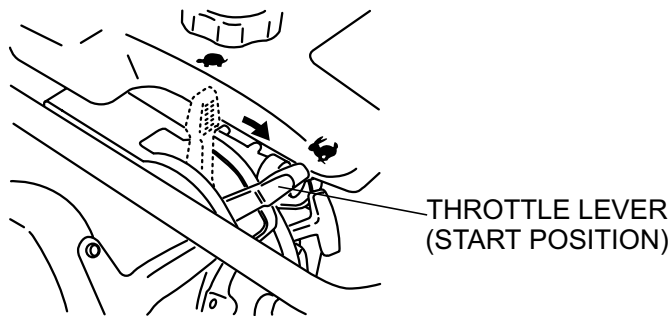

Figure 9. Throttle Lever (Start Position)

### ⚠ CAUTION

Make sure that the throttle lever is moved to the **FULL START** position. Operating the rammer at less than full speed can result in damage to the clutch springs or foot.

2. The MTX60HF tamping rammer is designed to run at 3,800 to 4,100 rpm. At optimum rpm the foot hits at the rate between 644 - 695 impacts per minute. Increasing throttle speed past factory set rpm does not increase impacts and may damage unit. The MTX60HF is designed to advance while tamping. For faster advance, pull back slightly on the handle so that rear of foot contacts soil first.
3. To stop the tamping action, move throttle lever quickly from **START** to **IDLE** position (Figure 6).

## STOPPING THE ENGINE

1. Move throttle lever quickly from the **START** to **IDLE** position (Figure 6) and run the engine for three minutes at low speed. After the engine **cools**, move the throttle lever to the **STOP** position (Figure 10). The engine will stop and the fuel cock is automatically closed.

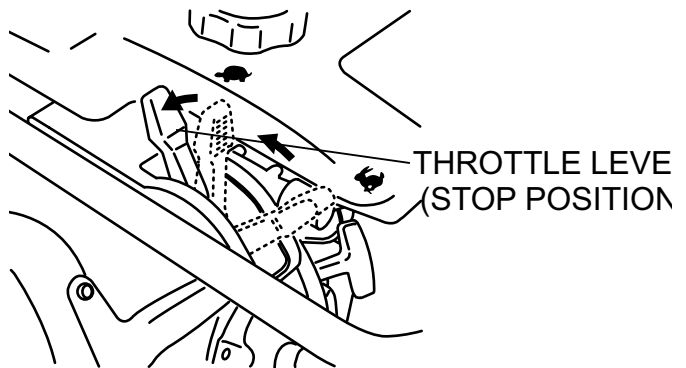

Figure 10. Throttle Lever (Stop Position)

2. If the engine does not stop due to a problem with the switch or the like, move the machine to a safe location and hold the throttle lever in the stop position. Let the machine run on idle and the machine will stop after a few minutes.



Perform the scheduled maintenance procedures as indicated:

## DAILY

- Thoroughly remove dirt and oil from the engine and control area.
- Clean or replace the air cleaner elements as necessary. Check and retighten all fasteners as necessary.
- Check the spring box and bellows for oil leaks. Repair or replace as needed.

## EVERY 50 HOURS

- Remove the fuel filter cap and clean the inside of the fuel tank (Figure 11).

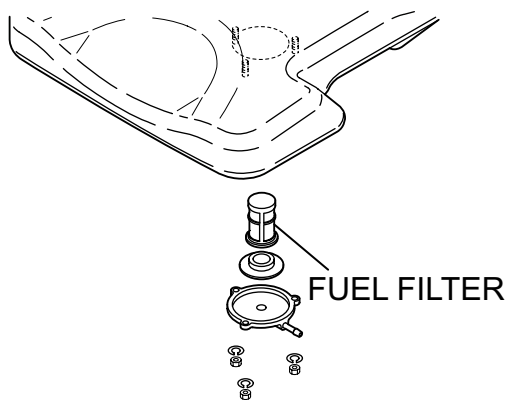

Figure 11. Fuel Filter

- Remove and clean the spark plug, then adjust the spark gap to 0.024~0.028 inch (0.6~0.7 mm).

## EVERY 80 TO 100 HOURS

- Remove the air cleaner cover. Loosen and remove the 2 screws that hold the cover to the air cleaner assembly. If the primary element (Figure 12) is dirty, wash it with gasoline or kerosene. Then dip it in engine oil (SAE10W-30) and wring the element so that 25 to 30 cc of engine oil remains on the element.

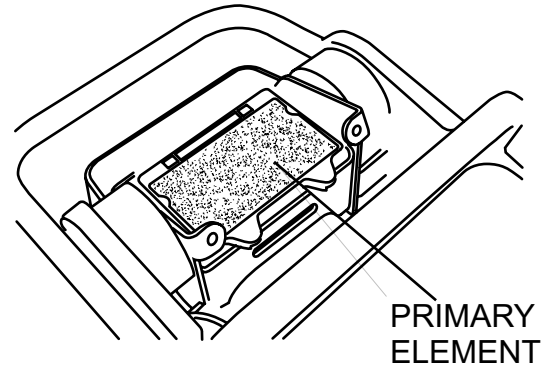

Figure 12. Air Cleaner Primary Element

## EVERY 200 HOURS

- Remove the oil drain plug on foot housing (Figure 13) and drain the oil. Refill with approximately 0.69 qt. (0.65 liter) of 10W-30 SE, SF or higher grade motor oil. Oil should be midway in sight glass. Break in oil should be changed after first 50 hours.

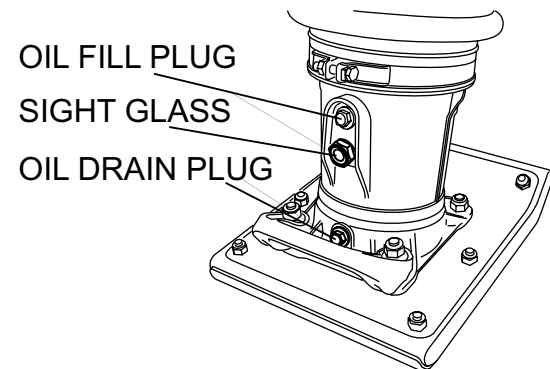

Figure 13. Oil Drain Plug

## EVERY 2 YEARS

- Replace the fuel line every 2 years even if there is no visible damage.

## LONG TERM STORAGE

- Slide the throttle lever to the **STOP** position.
- Drain any fuel including in the fuel hose.
- Replace lubrication oil and apply grease to lubrication points.
- Cover the air intake on the air cleaner and the exhaust outlet on the muffler.
- Store unit indoors covered with plastic sheet in moisture free and dust free location out of direct sunlight.

# TROUBLESHOOTING

<b>Troubleshooting (Engine)</b>		
<b>Symptom</b>	<b>Possible Problem</b>	<b>Solution</b>
Difficult to start, fuel is available, but no spark at spark plug.	Spark plug bridging?	Check gap, insulation or replace spark plug.
	Carbon deposit on spark plug?	Clean or replace spark plug.
	Short circuit due to deficient spark plug insulation?	Check spark plug insulation, replace if worn.
	Improper spark plug gap?	Set to proper gap.
	Fuel reaching carburetor?	Check fuel line.
	Water in fuel tank?	Flush or replace fuel tank.
	Fuel filter clogged?	Replace fuel filter.
	Stuck carburetor?	Check float mechanism.
	Spark plug is red?	Check transistor ignition unit.
	Spark plug is bluish white?	If insufficient compression, repair or replace engine. If injected air leaking, correct leak. If carburetor jets clogged, clean carburetor.
	No spark present at tip of spark plug?	Check transistor ignition unit is broken, and replace defective unit. Check if voltage cord cracked or broken and replace. Check if spark plug if fouled and replace.
	No oil?	Add oil as required.
	Oil pressure alarm lamp blinks upon starting? (if applicable)	Check automatic shutdown circuit, "oil sensor". (if applicable)
Difficult to start, fuel is available, and spark is present at the spark plug.	ON/OFF switch is shorted?	Check switch wiring, replace switch.
	Ignition coil defective?	Replace ignition coil.
	Improper spark gap, points dirty?	Set correct spark gap and clean points.
	Condenser insulation worn or short circuiting?	Replace condenser.
	Spark plug wire broken or short circuiting?	Replace defective spark plug wiring.
Difficult to start, fuel is available, spark is present and compression is normal.	Wrong fuel type?	Flush fuel system, and replace with correct type of fuel.
	Water or dust in fuel system?	Flush fuel system.
	Air cleaner dirty?	Clean or replace air cleaner.
	Choke open?	Close choke.
Difficult to start, fuel is available, spark is present and compression is low.	Suction/exhaust valve stuck or protruded?	Reseat valves.
	Piston ring and/or cylinder worn?	Replace piston rings and/or piston.
	Cylinder head and/or spark plug not tightened properly?	Torque cylinder head bolts and spark plug.
	Head gasket and/or spark plug gasket damaged?	Replace head and spark plug gaskets.
No fuel present at carburetor.	No fuel in fuel tank?	Fill with correct type of fuel.
	Fuel cock does not open properly?	Apply lubricant to loosen fuel cock lever, replace if necessary.
	Fuel filter/lines clogged?	Replace fuel filter.
	Fuel tank cap breather hole clogged?	Clean or replace fuel tank cap.
	Air in fuel line?	Bleed fuel line.

# TROUBLESHOOTING

Troubleshooting (Engine) - continued		
Symptom	Possible Problem	Solution
Weak in power, compression is proper and does not misfire.	Air cleaner dirty?	Clean or replace air cleaner.
	Improper level in carburetor?	Check float adjustment, rebuild carburetor.
	Defective spark plug?	Clean or replace spark plug.
	Improper spark plug?	Set to proper gap.
Weak in power, compression is proper but misfires.	Water in fuel system?	Flush fuel system and replace with correct type of fuel.
	Dirty spark plug?	Clean or replace spark plug.
	Ignition coil defective?	Replace ignition coil.
Engine overheats.	Spark plug heat value incorrect?	Replace with correct type of spark plug.
	Wrong type of fuel?	Replace with correct type of fuel.
	Cooling fins dirty?	Clean cooling fins.
	Intake air restricted?	Clear intake of dirt and debris. Replace air cleaner elements as necessary.
	Oil level too low or too high?	Adjust oil to proper level.
Rotational speed fluctuates.	Governor adjusted incorrectly?	Adjust governor.
	Governor spring defective?	Replace governor spring.
	Fuel flow restricted?	Check entire fuel system for leaks or clogs.
Recoil starter malfunctions. (if applicable)	Recoil mechanism clogged with dust and dirt?	Clean recoil assembly with soap and water.
	Spiral spring loose?	Replace spiral spring.
Starter malfunctions.	Loose, damaged wiring?	Ensure tight, clean connections on battery and starter.
	Battery insufficiently charged?	Recharge or replace battery.
	Starter damaged or internally shorted?	Replace starter.
Burns too much fuel.	Over-accumulation of exhaust products?	Check and clean valves. Check muffler and replace if necessary.
	Wrong spark plug?	Replace spark plug with manufacturer's suggested type.
Exhaust color is continuously "white".	Lubricating oil is wrong viscosity?	Replace lubricating oil with correct viscosity.
	Worn rings?	Replace rings.
Exhaust color is continuously "black".	Air cleaner clogged?	Clean or replace air cleaner.
	Choke valve set to incorrect position?	Adjust choke valve to correct position.
	Carburetor defective, seal on carburetor broken?	Replace carburetor or seal.
	Poor carburetor adjustment, engine runs too rich?	Adjust carburetor.
Will not start, no power with key "ON". (if applicable)	ON/OFF device not activated ON?	Turn on ON/OFF device.
	Battery disconnected or discharged?	Check cable connections. Charge or replace battery.
	Ignition switch/wiring defective?	Replace ignition switch. Check wiring.

# TROUBLESHOOTING

<b>Troubleshooting (Rammer)</b>		
<b>Symptom</b>	<b>Possible Problem</b>	<b>Solution</b>
Engine runs but rammer jumps erratically or not at all.	Operating speed of throttle lever is incorrectly set?	Set throttle lever to correct position.
	Oil in excess?	Drain excess oil. Bring to correct level.
	Clutch slips?	Replace or adjust clutch.
	Spring Failure?	Replace spiral spring.
	Speed of engine improper?	Adjust engine speed to correct operating RPM setting.
	Soil over-compacted?	Shut down machine and test soil.



# EXPLANATION OF CODE IN REMARKS COLUMN

The following section explains the different symbols and remarks used in the Parts section of this manual. Use the help numbers found on the back page of the manual if there are any questions.

## NOTICE

The contents and part numbers listed in the parts section are subject to change **without notice**. Multiquip does not guarantee the availability of the parts listed.

## SAMPLE PARTS LIST

NO.	PART NO.	PART NAME	QTY.	REMARKS
1	12345	BOLT .....	1	INCLUDES ITEMS W/%
2%		WASHER, 1/4 IN. ....		NOT SOLD SEPARATELY
2%	12347	WASHER, 3/8 IN. ...	1	MQ-45T ONLY
3	12348	HOSE .....	A/R	MAKE LOCALLY
4	12349	BEARING .....	1	S/N 2345B AND ABOVE

## NO. Column

**Unique Symbols** — All items with same unique symbol

(@, #, +, %, or >) in the number column belong to the same assembly or kit, which is indicated by a note in the “Remarks” column.

**Duplicate Item Numbers** — Duplicate numbers indicate multiple part numbers, which are in effect for the same general item, such as different size saw blade guards in use or a part that has been updated on newer versions of the same machine.

## NOTICE

When ordering a part that has more than one item number listed, check the remarks column for help in determining the proper part to order.

## PART NO. Column

**Numbers Used** — Part numbers can be indicated by a number, a blank entry, or TBD.

TBD (To Be Determined) is generally used to show a part that has not been assigned a formal part number at the time of publication.

A blank entry generally indicates that the item is not sold separately or is not sold by Multiquip. Other entries will be clarified in the “Remarks” Column.

## QTY. Column

**Numbers Used** — Item quantity can be indicated by a number, a blank entry, or A/R.

A/R (As Required) is generally used for hoses or other parts that are sold in bulk and cut to length.

A blank entry generally indicates that the item is not sold separately. Other entries will be clarified in the “Remarks” Column.

## REMARKS Column

Some of the most common notes found in the “Remarks” Column are listed below. Other additional notes needed to describe the item can also be shown.

**Assembly/Kit** — All items on the parts list with the same unique symbol will be included when this item is purchased.

Indicated by:

“INCLUDES ITEMS W/(unique symbol)”

**Serial Number Break** — Used to list an effective serial number range where a particular part is used.

Indicated by:

“S/N XXXXX AND BELOW”

“S/N XXXX AND ABOVE”

“S/N XXXX TO S/N XXX”

**Specific Model Number Use** — Indicates that the part is used only with the specific model number or model number variant listed. It can also be used to show a part is NOT used on a specific model or model number variant.

Indicated by:

“XXXXX ONLY”

“NOT USED ON XXXX”

**“Make/Obtain Locally”** — Indicates that the part can be purchased at any hardware shop or made out of available items. Examples include battery cables, shims, and certain washers and nuts.

**“Not Sold Separately”** — Indicates that an item cannot be purchased as a separate item and is either part of an assembly/kit that can be purchased, or is not available for sale through Multiquip.

## SUGGESTED SPARE PARTS

---

### MTX60HF RAMMER WITH HONDA GX100UKRB5 ENGINE

#### 1 TO 3 UNITS

Qty.	P/N	Description
1.....	956100062 .....	THROTTLE WIRE
3.....	366010070 .....	PRIMARY ELEMENT, AIR CLEANER
3.....	366010080 .....	SECONDARY ELEMENT, AIR CLEANER
1.....	366345570 .....	CAP, FUEL TANK W/ STRAP
2.....	16910Z4ES21 .....	FILTER, IN-LINE FUEL
3.....	9805655777 .....	SPARK PLUG
1.....	954406010 .....	STRAINER, FUEL TANK
1.....	28462Z0DV03 .....	ROPE, RECOIL STARTER

#### NOTICE

Part numbers on this Suggested Spare Parts list may supersede/replace the part numbers shown in the following parts lists.

# NAMEPLATES AND DECALS

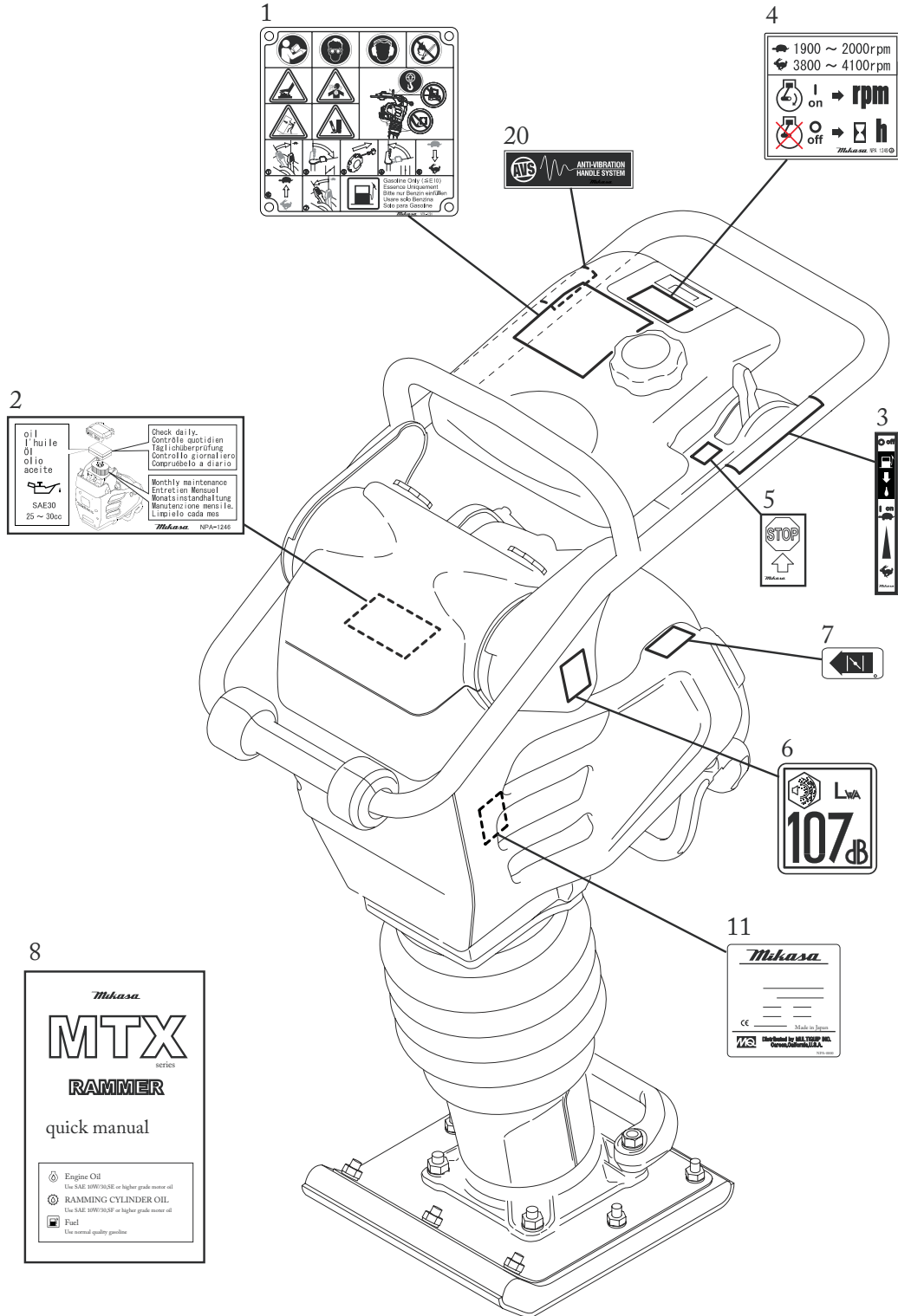



## NAMEPLATES AND DECALS

---

<u>NO.</u>	<u>PART NO.</u>	<u>PART NAME</u>	<u>QTY.</u>	<u>REMARKS</u>
1	920212910	OPERATION DECAL	1	
2	920212460	AIR CLEANER DECAL .....	1.....	NPA-1246
3	920212470	LEVER OPERATION DECAL	1	
4	920212490	MAX SPEED DECAL 4100	1	
5	920212480	MACHINE STOP DECAL	1	
6	920210310	EC NOISE REQ. DECAL LWA107	1	
7	920212840	CHOKE OPERATION DECAL	1	
8	920212540	QUICK MANUAL	1	
11		SERIAL PLATE NO. ....	1.....	CONTACT MQ PARTS DEPT.
12	920214100	E/G FIRE WARNING. DECAL	1	
20	920213730	ANTI- VIB. HANDLE DECAL	1	

# CRANKCASE AND ENGINE ASSY

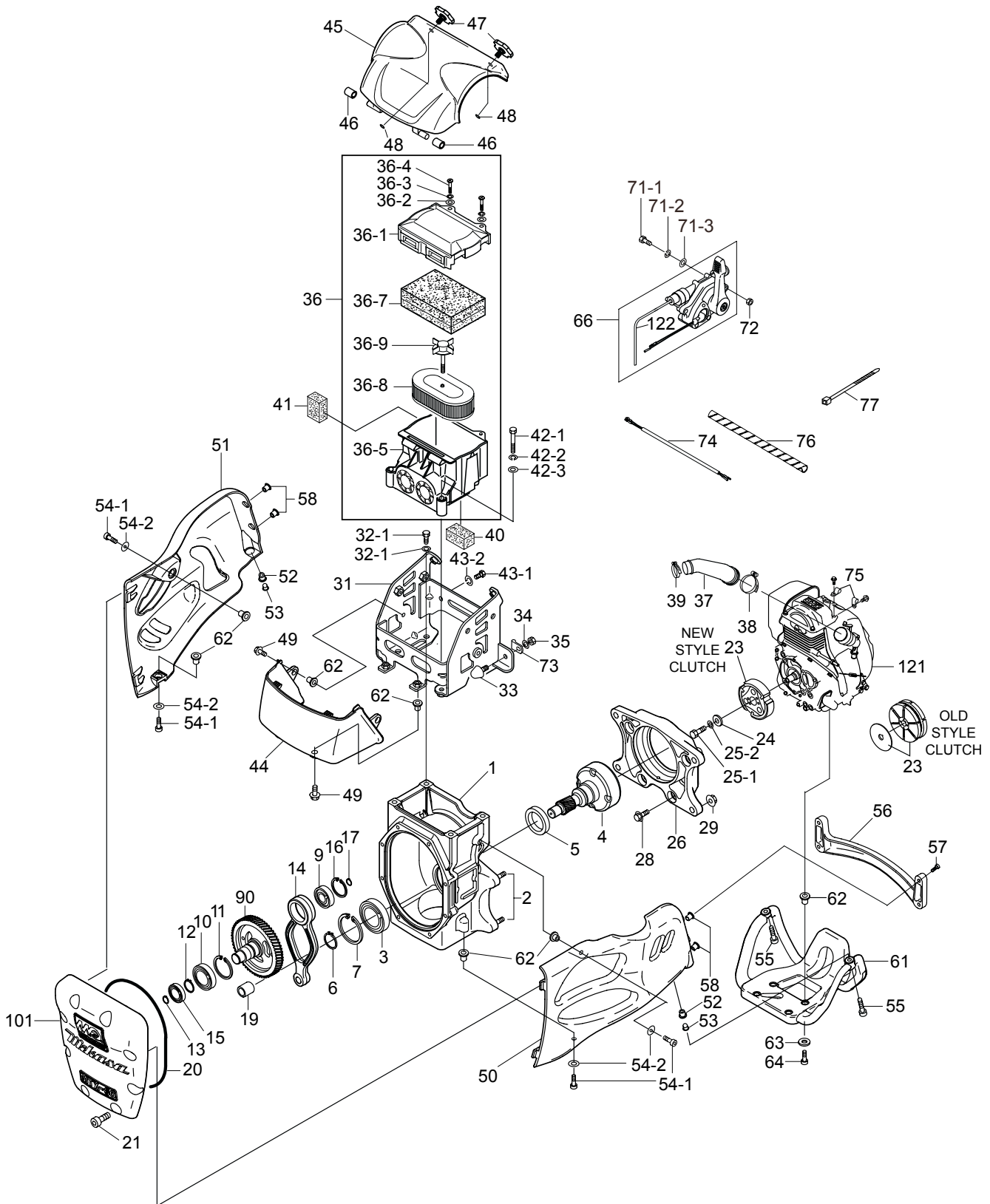

## CRANKCASE AND ENGINE ASSY

<u>NO.</u>	<u>PART NO.</u>	<u>PART NAME</u>	<u>QTY.</u>	<u>REMARKS</u>
1	368119170	CRANKCASE CP.....	1.....	INCLUDES ITEM W/ *
2*	009120204	STUD BOLT 10X50X21T/21S	4	
3	041006007	BEARING 6007Z	1	
4	368347410	PINION DRUM	1	
5	060404010	OIL SEAL TC - 40528	1	
6	080200350	STOP RING S-35	1	
7	080100620	STOP RING R-62	1	
9	040006203	BEARING 6203	1	
10	040006305	BEARING 6305	1	
11	080100620	STOP RING R62	1	
12	080200170	STOP RING S-17	1	
13	080200250	STOP RING R-62	1	
14	368347250	CONNECTING ROD	1	
15	040006304	BEARING 6304	1	
16	080100520	STOP RING R- 52	1	
17	080200200	STOP RING S- 20	1	
19	047940060	NEEDLE BEARING FJ- 1816	1	
20	050710100	O- RING AS568- 267	1	
21	001520825	SOCKET HEAD BOLT 8X25 T	8	
23	366348550	CLUTCH ASSY	1	
24	952401450	WASHER 8.5X22X3	1	
25-1	001220825	BOLT 8X25 T	1	
25-2	030208200	WASHER, LOCK M8	1	
26	368217640	ENGINE FLANGE	1	
28	001710840	SOCKET HEAD BOLT 8X40 T	4	
29	022611010	FLANGE NUT M10 H	4	
31	368347490	SHOCK ABSORBER BRACKET 60	1	
32-1	001211030	BOLT 10X30 H	4	
32-2	030210250	WASHER, LOCK M10	4	
33	939010270	STOPPER RUBBER (70)	1	
34	030208200	WASHER, LOCK M8	1	
35	020308060	NUT M8	1	
36	366118640	AIR CLEANER ASSY .....	1.....	INCLUDES ITEMS W/ #
36-1#	366010010	AIR CLEANER COVER	1	
36-2#	366010020	WASHER, FLAT M6 (6.5X18X1.5)	2	
36-3#	030206150	WASHER, LOCK M6	2	
36-4#	366010040	COIN BOLT M6	2	
36-5#	366010050	AIR CLEANER BASE CP	1	
36-7#	366010070	PRIMARY ELEMENT CP	1	
36-8#	366010080	SECONDARY ELEMENT	1	
36-9#	366030040	GRIP BPLT CP	1	
37	366345470	INTAKE PIPE	1	
38	954407681	CYCLONE CLAMP (CY- 1) 45	1	
39	954407682	CYCLONE CLAMP (CY- 1) 38	1	
40	366460160	UNDER SEALING FORM	1	

# CRANKCASE AND ENGINE ASSY

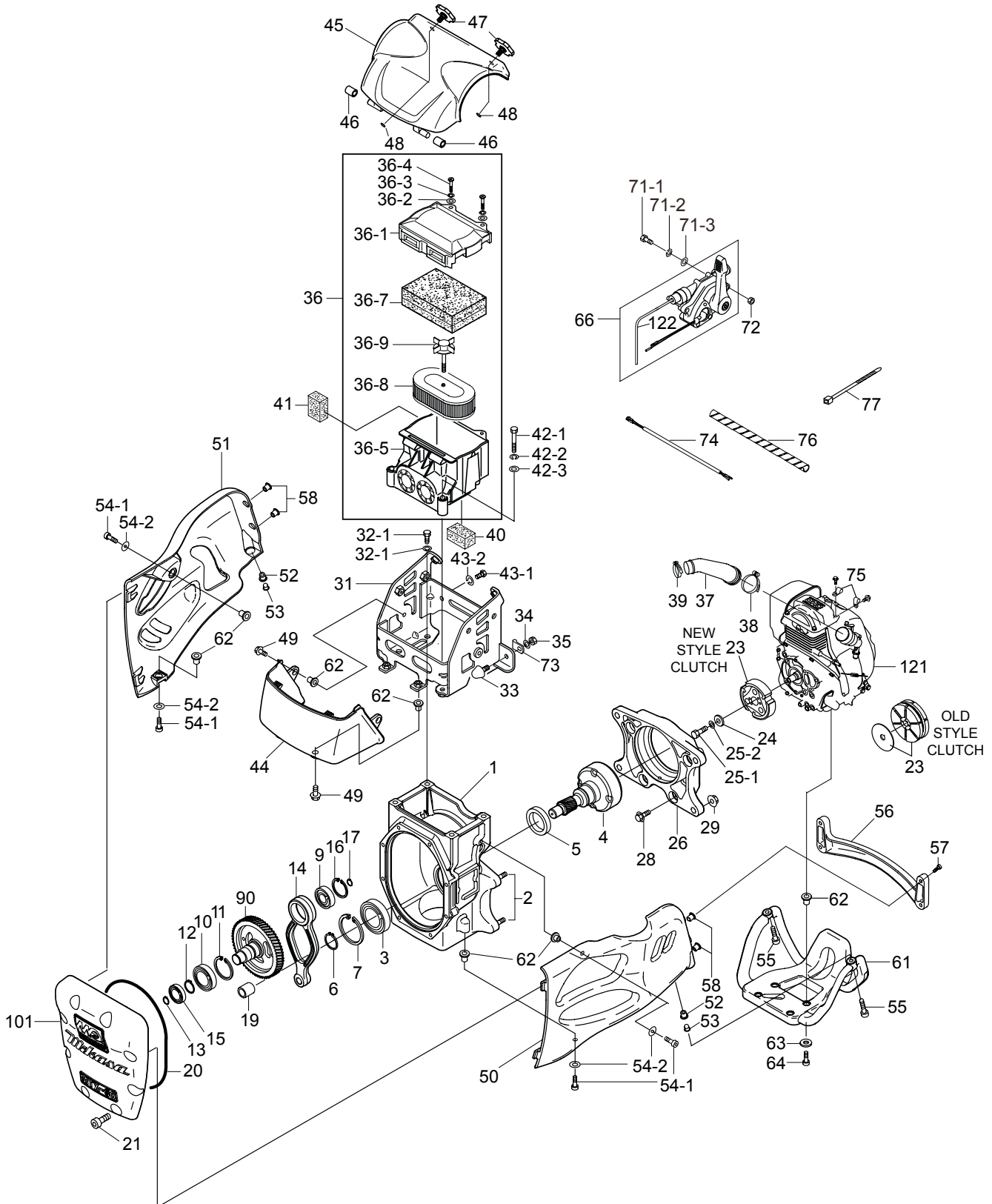

## CRANKCASE AND ENGINE ASSY

<u>NO.</u>	<u>PART NO.</u>	<u>PART NAME</u>	<u>QTY.</u>	<u>REMARKS</u>
41	366460150	SIDE SEALING FORM	1	
42-1	001220851	BOLT 8X55 T	2	
42-2	030208200	WASHER, LOCK M8	2	
42-3	031108160	WASHER, FLAT M8	2	
43-1	001210815	BOLT 8X15 H	2	
43-2	030208200	WASHER, LOCK M8	2	
44	368217760	BOTTOM CLEANER COVER 60	1	
45	368217750	TOP CLEANER COVER 60	1	
46	366460140	RUBBER BUSH 10X16X17	2	
47	366345980	CLEANER COVER KNOB	2	
48	050200060	O- RING P6	2	
49	009110040	FLANGE BOLT 8X20	4	
50	368119470	LINK GUARD	1	
51	368119480	MUFFLER GUARD	1	
52	022910260	WELL NUT M8	2	
53	366460170	FLANGE COLLAR 8	2	
54-1	001520820	SOCKET HEAD BOLT 8X20 T	4	
54-2	033910220	WASHER, FLAT M8	4	
55	009110038	SOCKET HEAD BOLT 8X30 ZN	2	
56	368217770	EX BAR	1	
57	009110039	SOCKET HEAD BOLT 6X25 ZN	4	
58	022910250	WELL NUT M6	4	
61	368119490	ENGINE GUARD	1	
62	366461050	COLLAR /GUARD	12	
63	033910220	WASHER 8.4X15.5X1.6	4	
64	009110038	SOCKET HEAD BOLT 8X30 ZN	4	
66	956200110	LEVER ASSY W/ T. WIRE.....	1	INCLUDES ITEMS W/@
71-1	001220620	BOLT 6X20 T	2	
71-2	030206150	WASHER, LOCK M6	2	
71-3	031106100	WASHER, FLAT M6	2	
72	020306050	NUT M6	2	
73	959006120	CLIP (TCP2 - 10509B)	1	
74	368461280	WIRE HARNESS	1	
75	2067550101	CLAMP COMPL	2	
76	959021814	SPIRAL TUBE KEP6 / L=200	1	
77	454010020	CLAMP TC- 100	3	
90	368347270	CRANK GEAR	1	
101	368010010	FRONT COVER	1	
121	912210017	ENGINE ASSY, GX100UKRB5	1	
122@	956100062	THROTTLE WIRE	1	

# GUIDE CYLINDER ASSY

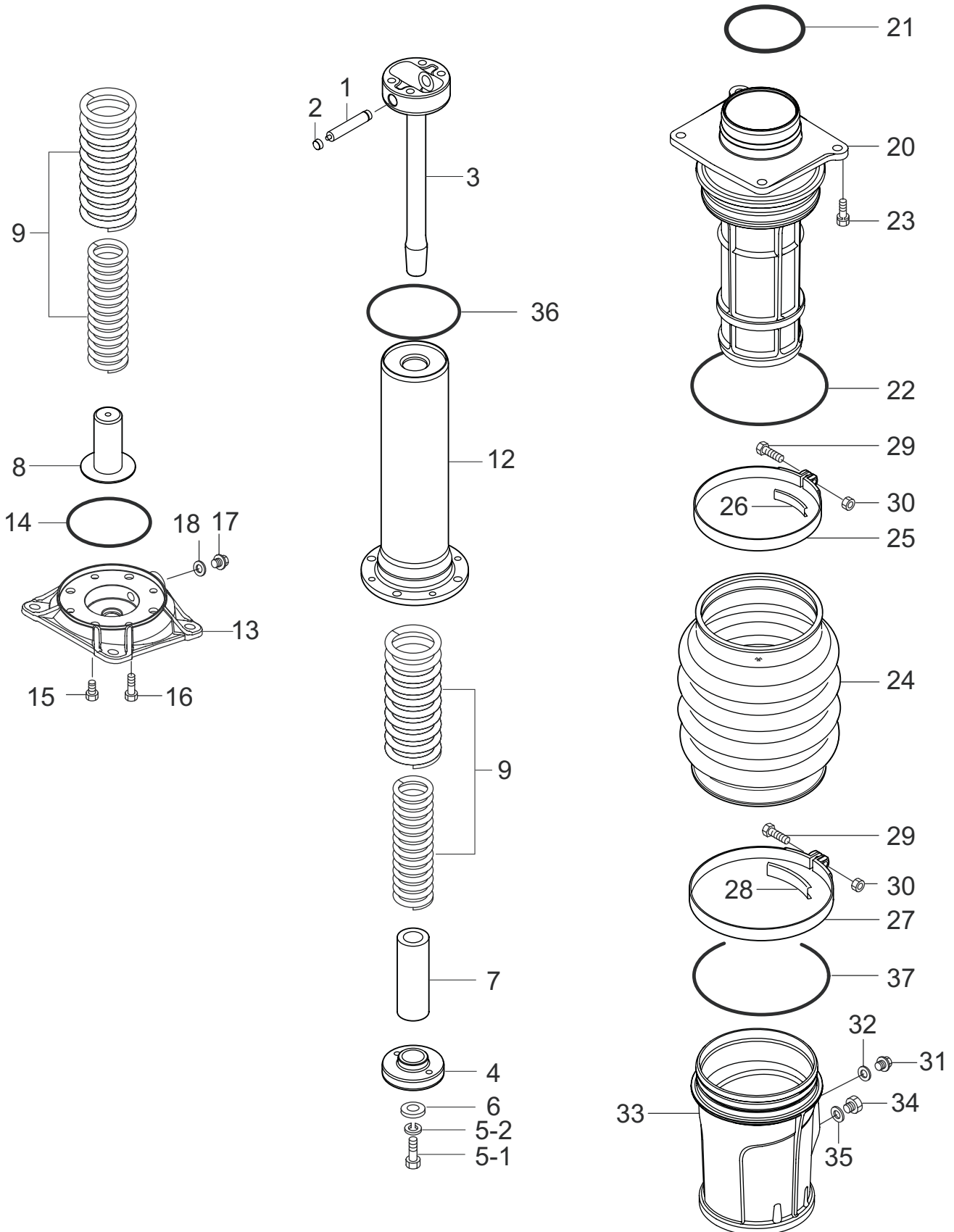

## GUIDE CYLINDER ASSY

<u>NO.</u>	<u>PART NO.</u>	<u>PART NAME</u>	<u>QTY.</u>	<u>REMARKS</u>
1	368461210	PISTON PIN	1	
2	368459920	PISTON PIN PLUG	2	
3	368347290	PISTON ROD	1	
4	368461160	PISTON END	1	
5-1	001121230	BOLT 12X30 T	1	
5-2	030212300	WASHER, LOCK M12	1	
6	952404790	WASHER 13306	1	
7	368461260	LOWER STOPPER	1	
8	368461200	BOTTOM STOPPER	1	
9	368461270	MAIN SPRING	2	
12	368347281	SPRING CYLINDER.....	1.....	REPLACES P/N 368347280
13	368217710	FOOT PLATE	1	
14	050100800	O- RING G- 80	1	
15	001521020	SOCKET HEAD BOLT 15X20 T	4	
16	001520835	SOCKET HEAD BOLT 8X25 T	4	
17	953405270	PLUG 1/4X14 13L	1	
18	953405260	PACKING 1/4 (CU)	1	
20	368217720	CYLINDER GUIDE	1	
21	050100850	O- RING G-85	1	
22	050101150	O- RING G-115	1	
23	002211035	BOLT 10X35 H, SW4	4	
24	368346180	ORANGE BELLOWS	1	
25	368347520	BELLOWS CLAMP131D	1	
26	368461400	BAND GUIDE 131D	1	
27	368347530	BELLOWS CLAMP 149D	1	
28	368461410	BAND GUIDE 149D	1	
29	001220840	BOLT 8X40 T	2	
30	020308060	NUT M8	2	
31	953405270	PLUG 1/4X14 13L	1	
32	953405260	PACKING 1/4 (CU)	1	
33	368118970	PROTECTION SLEEVE	1	
34	366460300	OIL GAUGE ASSY	1	
35	953404670	COPPER PACKING 17X25.5X1	1	
36	050200800	O- RING P- 80	1	
37	050101300	O- RING G-130	1	

# FOOT ASSY

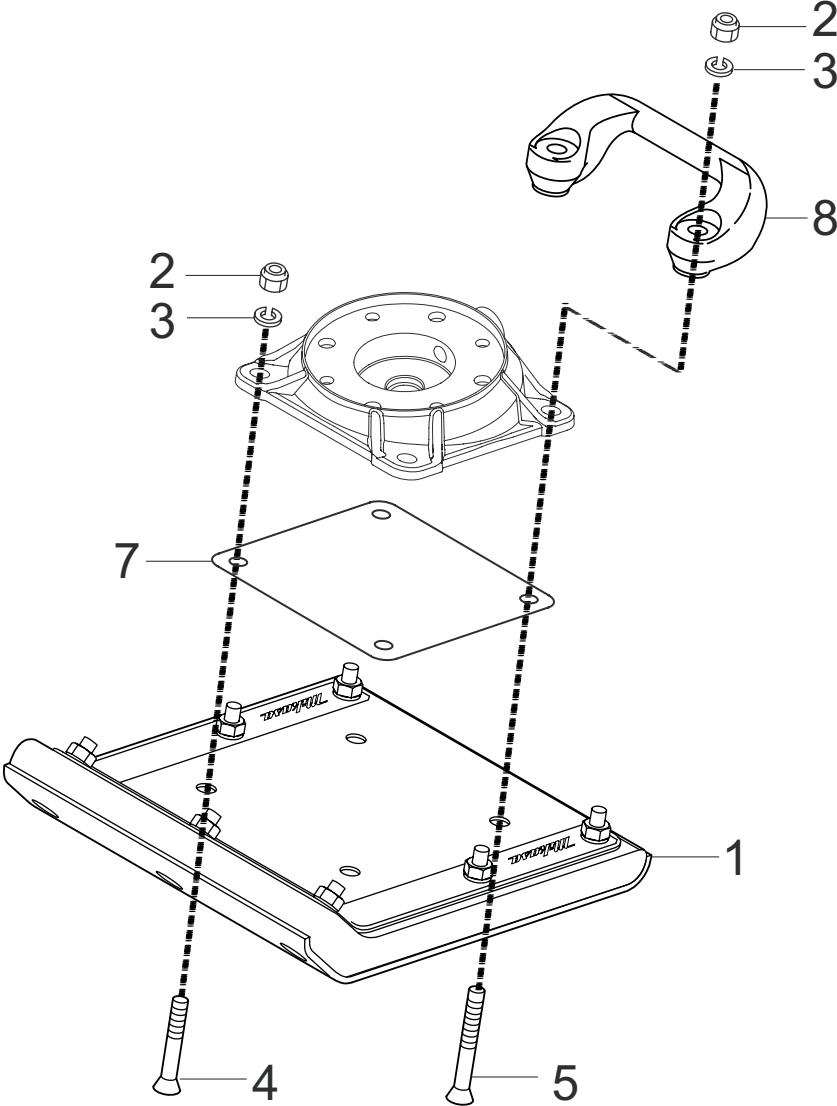



## FOOT ASSY

---

<u>NO.</u>	<u>PART NO.</u>	<u>PART NAME</u>	<u>QTY.</u>	<u>REMARKS</u>
1	362910150	FOOT ASSY 265W M4B	1	
2	022711214	NYLON NUT M12	4	
3	030212300	WASHER, LOCK M12	4	
4	009110034	SQUARE NECK BOLT 12X65	2	
5	009110035	SQUARE NECK BOLT 12X95	2	
7	368347460	FOOT COVER	1	
8	363343390	HANDLEBAR GRIP (FOOT)	1	

# FUEL TANK AND HANDLE ASSY

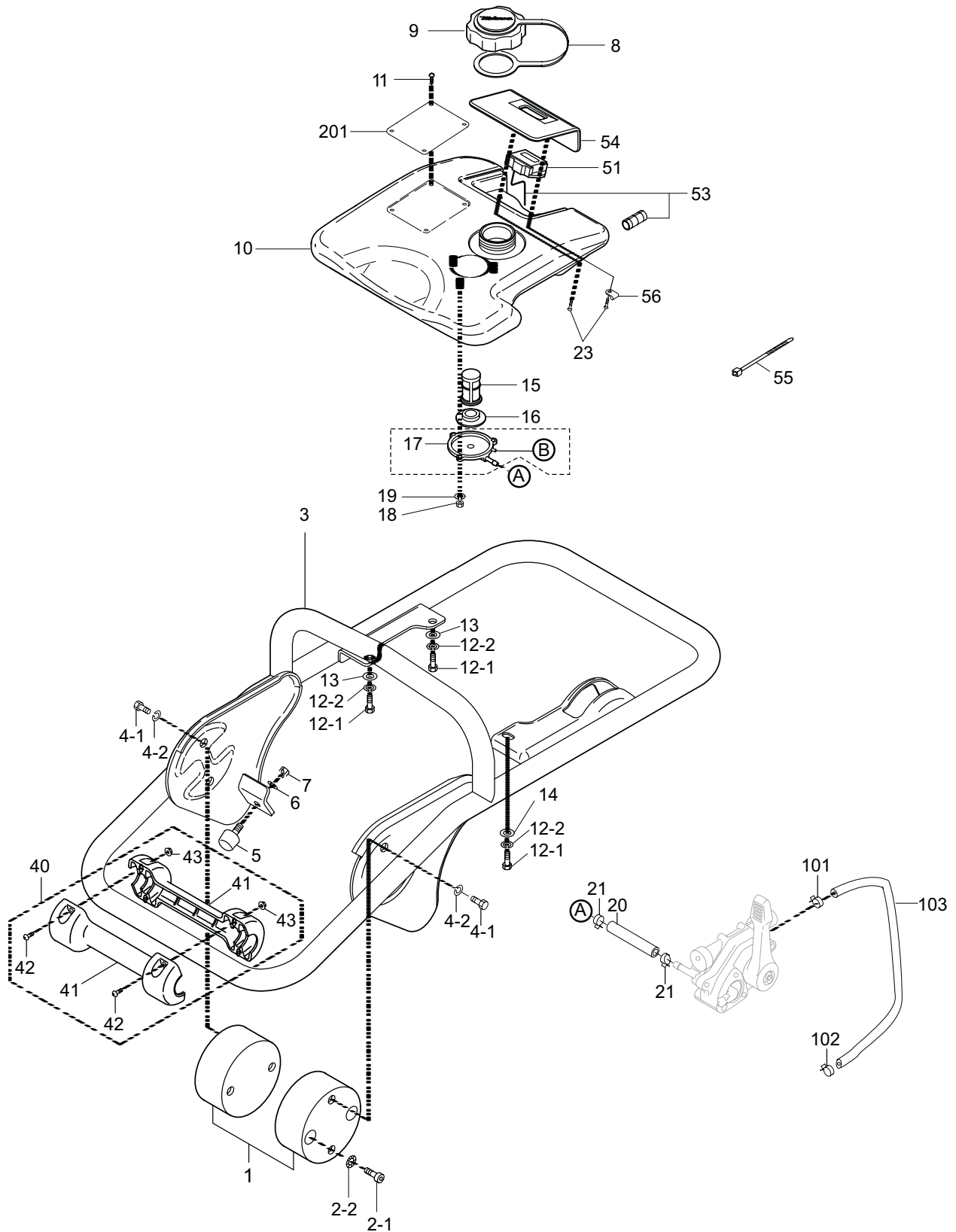

## FUEL TANK AND HANDLE ASSY

<u>NO.</u>	<u>PART NO.</u>	<u>PART NAME</u>	<u>QTY.</u>	<u>REMARKS</u>
1	368347630	SHOCK ABSORBER W/ PIN	2	
2-1	001521020	SOCKET HEAD BOLT 10X20 T	4	
2-2	033121009	TOOTHED LOCK WASHER B M10	4	
3	368119570	HANDLE	1	
4-1	001211020	BOLT 10X20 H	4	
4-2	030210250	WASHER, LOCK M10	4	
5	939010270	RUBBER STOPPER (70)	1	
6	030208200	WASHER, LOCK M8	1	
7	020308060	NUT M8	1	
8*	366010060	TANK CAP STRAP	1	
9	366350010	FUEL TANK CAP ASSY.....	1	INCLUDES ITEM W/ *
10	368119460	FUEL TANK 2L	1	
11	094010053	PAN HEAD SCREW 4X8	4	
12-1	001210815	BOLT 8X15 H	3	
12-2	030208200	WASHER, LOCK M8	3	
13	952401450	WASHER 8.5X22X3	2	
14	031108160	WASHER, FLAT M8	1	
15	954406010	STRAINER #110	1	
16	366459790	FUEL TANK PACKING	1	
17	366345280	FILTER HOLDER	1	
18	020305040	NUT M5	3	
19	030205130	WASHER, LOCK M5	3	
20	959328401	FUEL HOSE L=70	1	
21	0561080020	HOSE BAND	2	
23	009110037	TAPPING SCREW 5X20	2	
40	366910030	ROLLER ASSY W/ SCREW.....	1	INCLUDES ITEM W/ #
41#	366217170	ROLLER	2	
42#	091005020	SCREW 5X20	4	
43#	022610505	FLANGE NUT M5 H	4	
51	980010330	TACHO & HOUR METER	1	
53	980010400	CURL CORD TP-22	1	
54	366345620	METER FINISHER	1	
55	454010020	CLAMP TC-100	5	
56	954010270	CLIP AB-3N	1	
101	954407060	HOSE BAND 9	1	
102	950024085008	HOSE BAND 5-5-2	1	
103	91434Z4EW51	FUEL HOSE 350	1	
201	920212910	OPERATION DECAL	1	

# COMBINATION LEVER ASSY

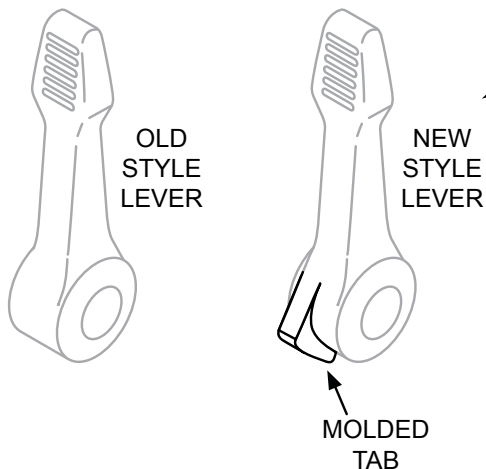
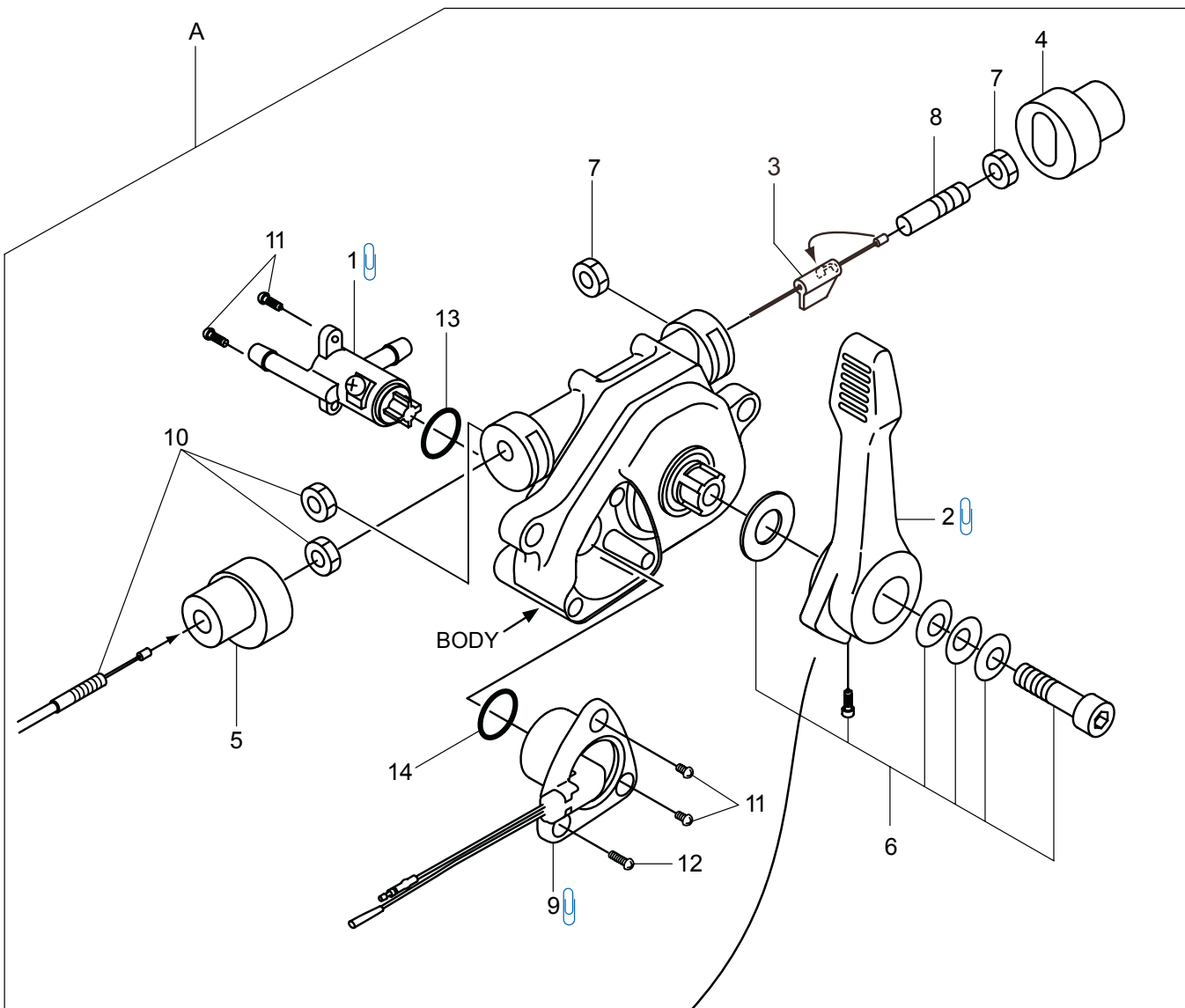

## NOTES

 OLD STYLE LEVER BODY NO LONGER AVAILABLE. NEW STYLE ITEMS 1, 2, AND 9 ARE NOT COMPATIBLE WITH OLD STYLE BODY. IF REPLACEMENT OF ITEMS 1, 2 OR 9 IS REQUIRED, ORDER KIT "A".

TO DETERMINE IF COMBINATION LEVER ASSY IS OLD STYLE OR NEW STYLE, SEE ITEM 2, LEVER. NEW STYLE LEVER HAS MOLDED TAB AT BOTTOM.

## COMBINATION LEVER ASSY

<b>NO.</b>	<b>PART NO.</b>	<b>PART NAME</b>	<b>QTY.</b>	<b>REMARKS</b>
A	956200110	COMB. LEVER ASSY .....	1.....	INCLUDES ITEMS W/@
1	366346260	FUEL COCK .....	1.....	SEE NOTE ON DRAWING
1#@	366349430	FUEL COCK .....	1.....	NEW STYLE SEE NOTE ON DRAWING
2	366010180	LEVER .....	1.....	SEE NOTE ON DRAWING
2#@	366010310	LEVER .....	1.....	NEW STYLE SEE NOTE ON DRAWING
3#@	366010190	SLIDER	1	
4#@	366010200	END CAP	1	
5#@	366010210	WIRE CAP	1	
6#@	366010220	BOLT AND WASHER SET	1	
7#@	020408050	NUT M8, H=5	2	
8#@	959407650	SOCKET HEAD SCREW/TH.WIRE	1	
9	366010260	STOP SWITCH .....	1.....	SEE NOTE ON DRAWING
9#@	366010320	STOP SWITCH .....	1.....	NEW STYLE SEE NOTE ON DRAWING
10#	956100062	THROTTLE WIRE	1	
11#@	094010051	TAPPING SCREW B1 4X12	4	
12#@	094010052	TAPPING SCREW B1 4X30	1	
13#@	050200150	O-RING, P15	1	
14#@	050200110	O-RING, P11	1	

# HONDA GX100UKRB5 ENGINE — CYLINDER BARREL ASSY.

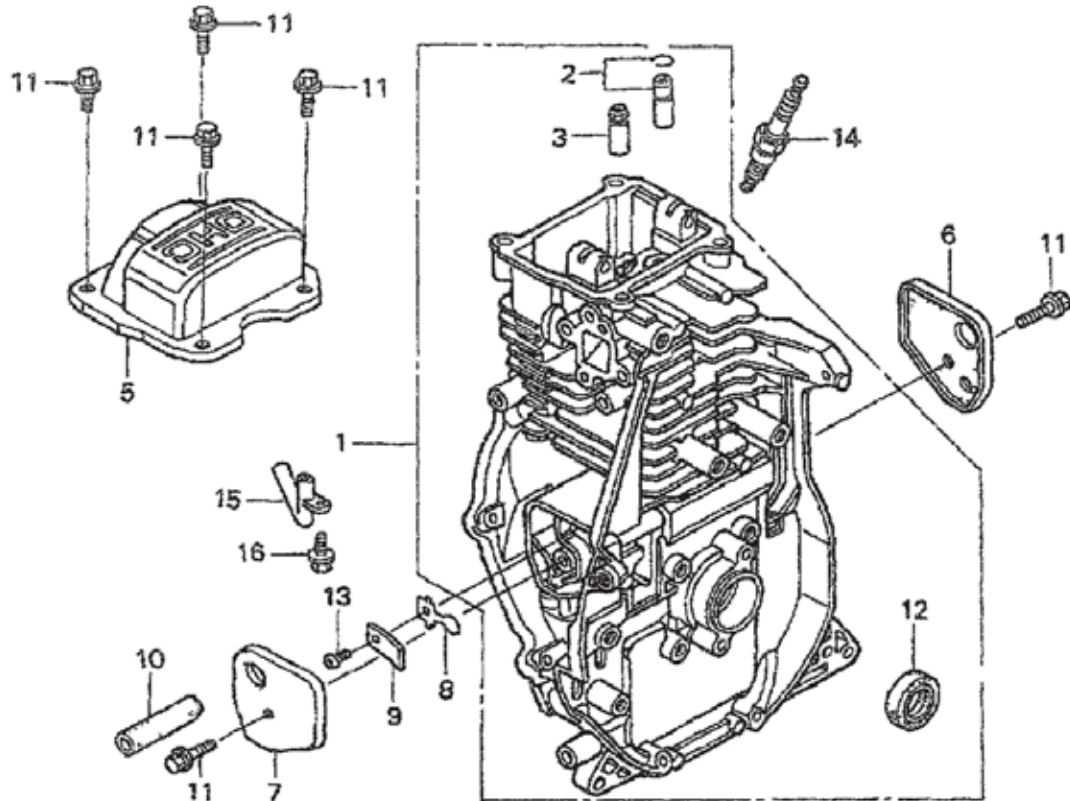

# HONDA GX100UKRB5 ENGINE — CYLINDER BARREL ASSY.

<u>NO.</u>	<u>PART NO.</u>	<u>PART NAME</u>	<u>QTY.</u>	<u>REMARKS</u>
1	12000Z0D405	BARREL ASSY., CYLINDER .....	1.....	INCLUDES ITEMS W/ *
2	12201Z0D305	GUIDE ASSY., EX VALVE (O.S.)	1	
3*	12204Z0D305	GUIDE, INLET VALVE (O.S)	1	
5	12311Z0D000	COVER, HEAD T	1	
6	12355Z0D000	COVER COMP A, BREATHER	1	
7	12365Z0D000	COVER COMP B, BREATHER	1	
8	15571Z0DV71	VALVE, OIL OUTLET	1	
9	15572ZM7000	PLATE, STOPPER	1	
10	15721Z0DV70	TUBE, BREATHER	1	
11	90014952000	BOLT, FLANGE 6X14 (CT200)	6	
12*	91202KJ9003	OIL SEAL 20X32X6	1	
13	93500030050A	SCREW 3X5	1	
14	9805655777	PLUG, SPARK (CR5HSB)	1	
15	15171Z0DV00	PIPE, BREATHER	1	
16	90008ZM7000	BOLT 4X10	1	

# HONDA GX100UKRB5 ENGINE — CRANKCASE COVER ASSY.

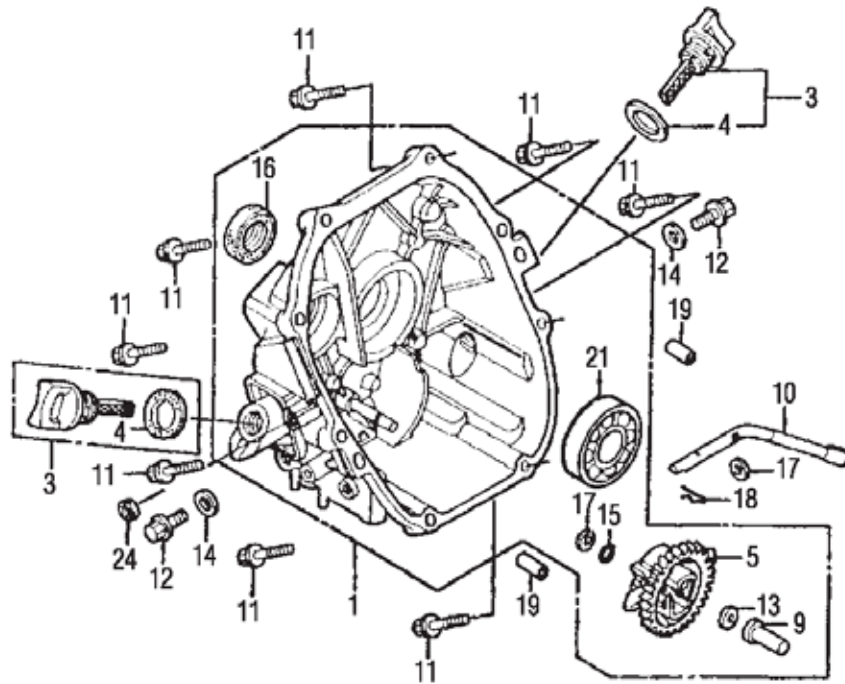



# HONDA GX100UKRB5 ENGINE — CRANKCASE COVER ASSY.

<u>NO.</u>	<u>PART NO.</u>	<u>PART NAME</u>	<u>QTY.</u>	<u>REMARKS</u>
1	11300Z0D409	COVER ASSY., CRANK CASE .....	1.....	INCLUDES ITEMS W/ *
3	15600ZM7003	OIL FILLER CAP ASSY .....	2.....	INCLUDES ITEMS W/ #
4#	15625ZE1003	PACKING, OIL FILLER CAP	2	
5*	16510ZL8000	GOVERNOR ASSY.	1	
9*	16531ZE1000	SLIDER, GOVERNOR	1	
10	16541Z0D000	SHAFT, GOVERNOR ARM	1	
11	90121952000	FLANGE BOLT 6x25	8	
12	90131ZE1000	BOLT, DRAIN PLUG	1	
13*	90451ZE1000	THRUST WASHER 6 MM	1	
14	90601ZE1000	WASHER, DRAIN PLUG	1	
15*	90602ZE1000	CLIP, GOVERNOR HOLDER	1	
16*	91202KJ9003	OIL SEAL 20x3x6	1	
17*	9410106800	PLAIN WASHER 6 MM	2	
18	9425108000	LOCK PIN	1	
19	9430108200	KNOCK PIN	2	
21*	91001Z0DV01	BEARING, RADIAL BALL 6204	1	
24	91231891003	OIL SEAL 6x11x4	1	

# HONDA GX100UKRB5 ENGINE — CRANKSHAFT ASSY.

---

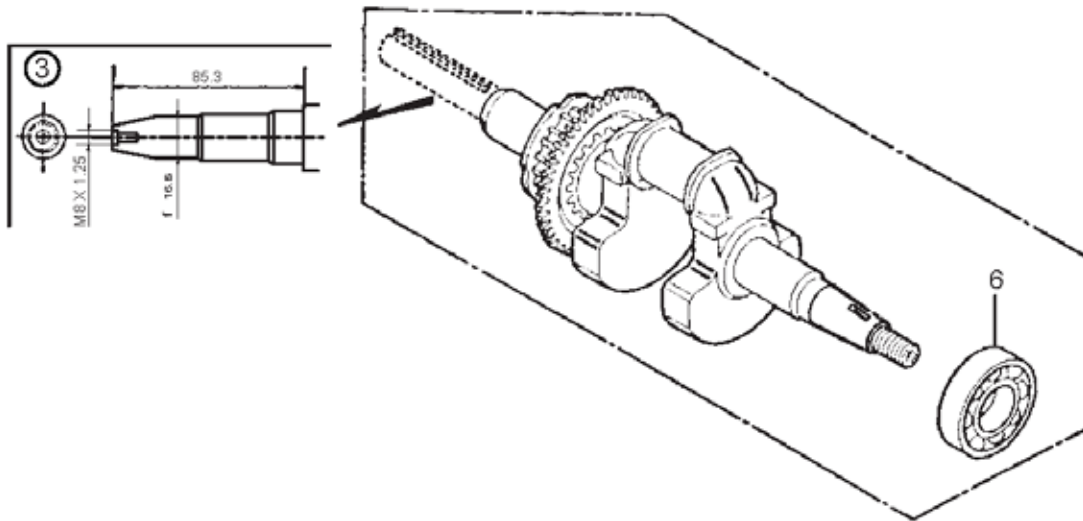

## HONDA GX100UKRB5 ENGINE — CRANKSHAFT ASSY.

---

<u>NO.</u>	<u>PART NO.</u>	<u>PART NAME</u>	<u>QTY.</u>	<u>REMARKS</u>
3	13310Z0DV70	CRANK SHAFT COMP.	1	INCLUDES ITEM W/ *
6*	91001Z0DV01	BEARING, RADIAL BALL	1	

# HONDA GX100UKRB5 ENGINE — PISTON/CONN. ROD ASSY.

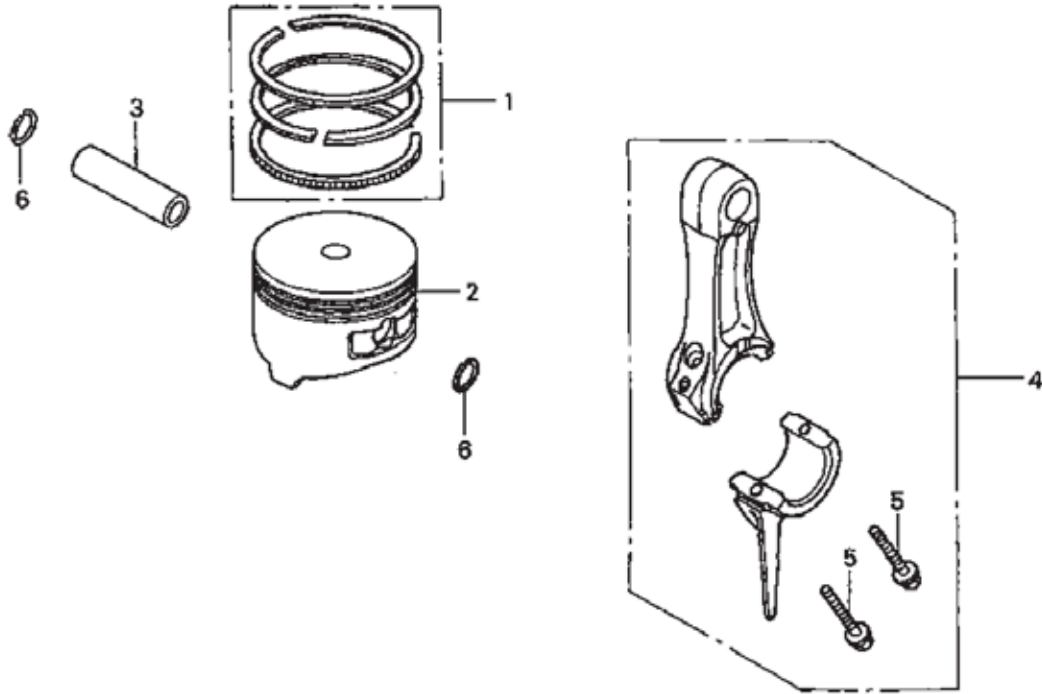

# HONDA GX100UKRB5 ENGINE — PISTON/CONN. ROD ASSY.

<u>NO.</u>	<u>PART NO.</u>	<u>PART NAME</u>	<u>QTY.</u>	<u>REMARKS</u>
1	13010Z0D003	RING SET, PISTON	1	
2	13101Z0D000	PISTON	1	
3	13111ZE0000	PISTON PIN	1	
4	13200Z0D000	CONNECTING ROD ASSY .....	1 .....	INCLUDES ITEM W/ *
4	13200Z0D305	CONNECTING ROD ASSY .....	1 .....	UNDERSIZED, INCLUDES ITEM W/ *
5*	90001ZM7000	CONNECTING ROD BOLT	2	
6	90551ZE0000	CLIP, PISTON PIN 13MM	2	

# HONDA GX100UKRB5 ENGINE — CAMSHAFT ASSY.

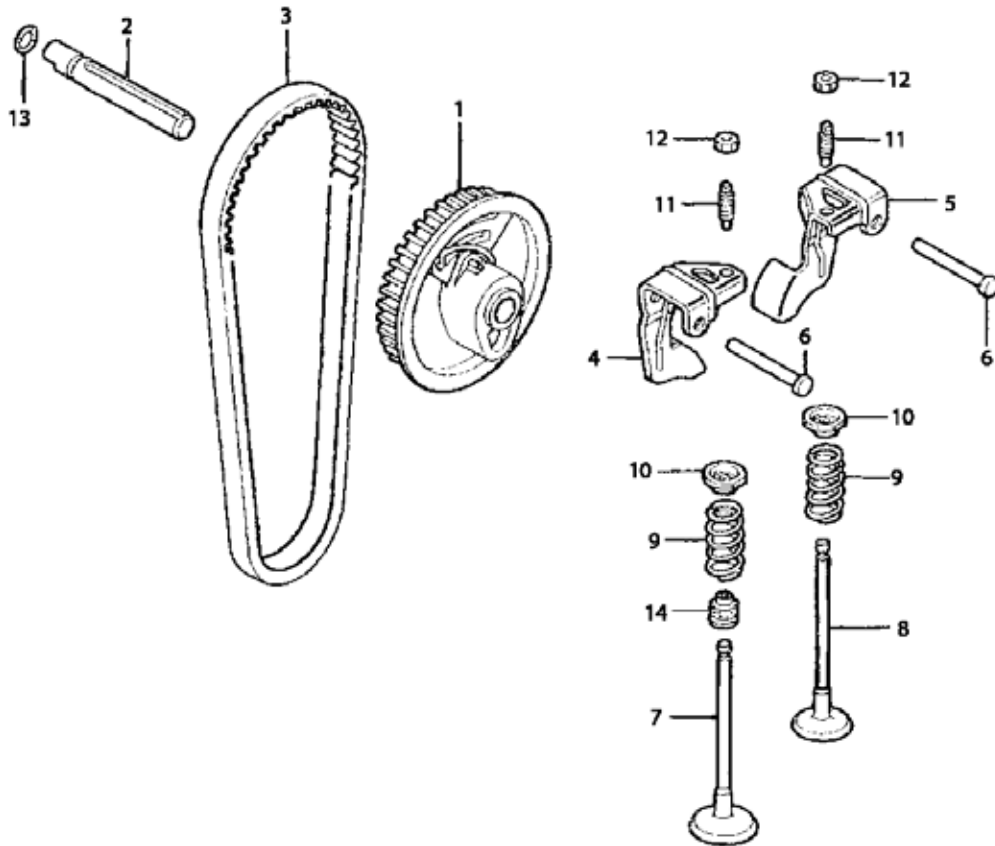

## HONDA GX100UKRB5 ENGINE — CAMSHAFT ASSY.

---

<u>NO.</u>	<u>PART NO.</u>	<u>PART NAME</u>	<u>QTY.</u>	<u>REMARKS</u>
1	14320Z0D010	PULLEY, COMP., CAMSHAFT	1	
2	14324Z0D000	SHAFT, CAM PULLEY	1	
3	14400Z0D003	TIMING BELT (61YU7 G-200)	1	
4	14431Z0D000	ROCKER ARM, INTAKE VALVE	1	
5	14441Z0D000	ROCKER ARM, EXHAUST VALVE	1	
6	14461ZL8000	SHAFT, ROCKER ARM	2	
7	14721Z0D000	INLET VALVE	1	
8	14721Z0D000	EXHAUST VALVE	1	
9	14751Z0D000	SPRING, VALVE	2	
10	14751ZM3010	RETAINER, VALVE SPRING	1	
11	90012333000	SCREW, TAPPET ADJUSTING	2	
12	90206001000	NUT, TAPPET ADJUSTING	2	
13	91301ZM0V31	O RING 6.8X1.9	1	
14	12209KT7013	SEAL, VALVE STEM	1	

# HONDA GX100UKRB5 ENGINE — RECOIL STARTER ASSY.

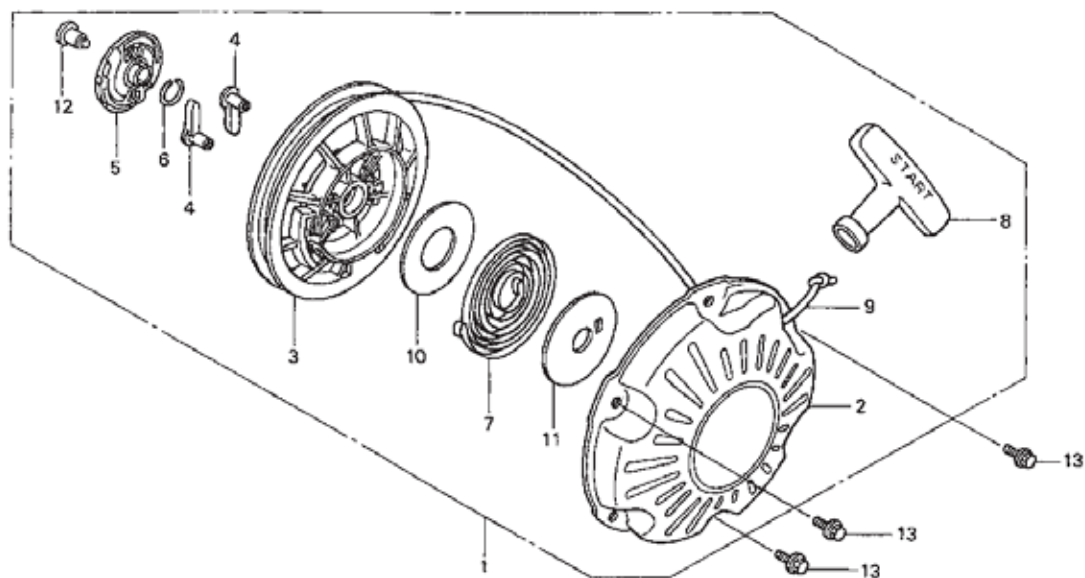



# HONDA GX100UKRB5 ENGINE — RECOIL STARTER ASSY.

---

<u>NO.</u>	<u>PART NO.</u>	<u>PART NAME</u>	<u>QTY.</u>	<u>REMARKS</u>
1	28400Z0DV04ZA	RECOIL STARTER ASSY.....	1.....	INCLUDES ITEMS W/ *
2*	28410Z0DV02ZA	CASE COMP., RECOIL *5-3-5	1	
3*	28421Z0DV02	REEL, RECOIL STARTER	1	
4*	28422ZG0W02	RATCHET, STARTER	2	
5*	28433ZG0W02	GUIDE, RATCHET	1	
6*	28441ZW6003	SPRING, FRICTION	1	
7*	28442ZH8003	SPRING, RECOIL STARTER	1	
8*	28461ZH8013	STARTER KNOB	1	
9*	28462Z0DV03	ROPE, RECOIL STARTER	1	
10*	28467Z0DV02	PLATE, SIDE	1	
11*	28468Z0DV02	PLATE, SLIDE	1	
12*	90003ZH8003	SET SCREW	1	
13	957010600800	BOLT, FLANGE 6X8	1	

# HONDA GX100UKRB5 ENGINE — FAN COVER ASSY.

---

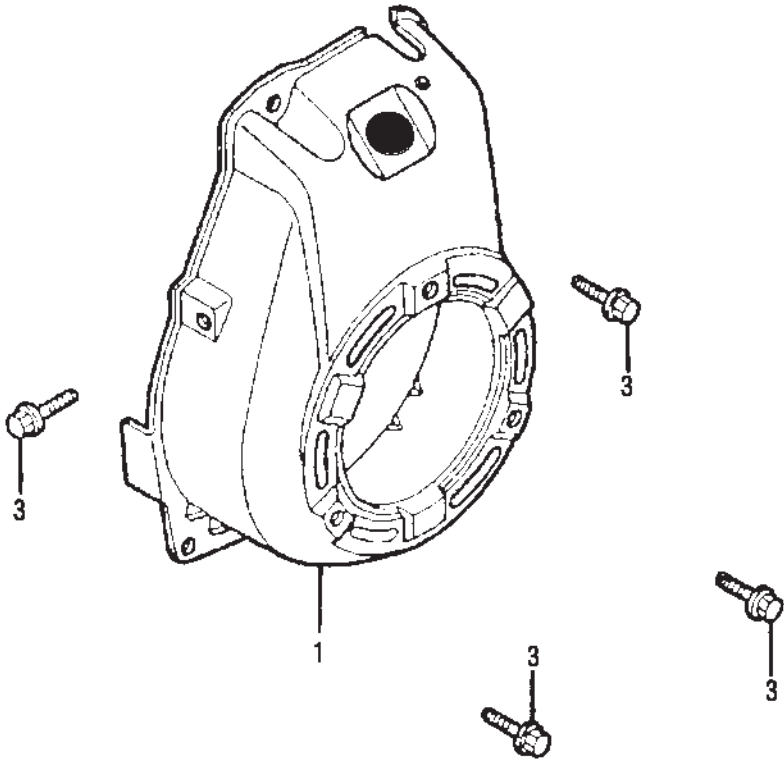

## HONDA GX100UKRB5 ENGINE — FAN COVER ASSY.

---

<u>NO.</u>	<u>PART NO.</u>	<u>PART NAME</u>	<u>QTY.</u>	<u>REMARKS</u>
1	19610Z4ES30ZA	FAN COVER CP.	1	
3	90014952000	BOLT, FLANGE 6X14 (CT200)	4	

# HONDA GX100UKRB5 ENGINE — CARBURETOR ASSY.

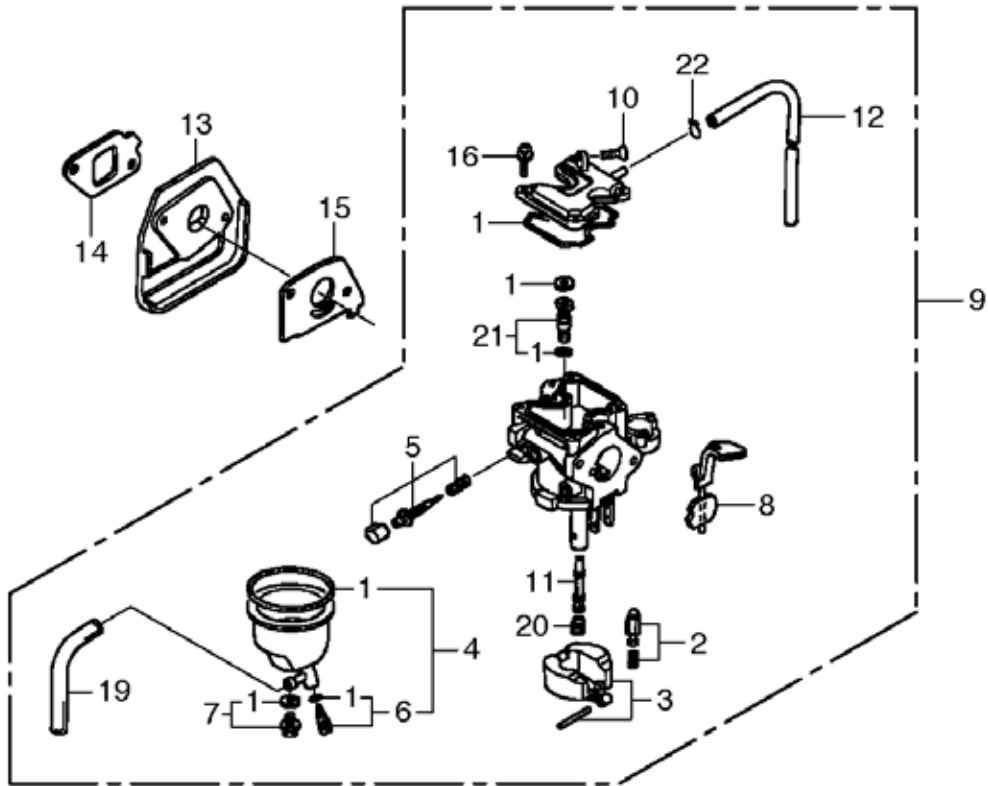

## HONDA GX100UKRB5 ENGINE — CARBURETOR ASSY.

<u>NO.</u>	<u>PART NO.</u>	<u>PART NAME</u>	<u>QTY.</u>	<u>REMARKS</u>
1#	16010Z0DV21	GASKET SET	1	
2#	16011ZE0005	FLOAT VALVE SET	1	
3#	16013ZG0811	FLOAT SET	1	
4#	16015Z0DV21	FLOAT CHAMBER SET	1	
5#	16016Z0DV21	SCREW SET	1	
6#	16024ZB9005	DRAIN SCREW SET	1	
7#	16028ZW6611	SCREW SET	1	
8#	16044Z0DS01	LEVER SET, CHOKE	1	
9#	16100Z4EW51	CARBURETOR ASSY .....	1	INCLUDES ITEMS W/ #
10#	16124ZE0005	SCREW, THROTTLE STOP	1	
11#	16166Z0D003	MAIN NOZZLE	1	
12#	16199Z0DV21	TUBE, VENT	1	
13	16211Z0D000	INSULATOR, CARBURETOR	1	
14	16212Z0DV20	PACKING, INSULATOR	1	
15	16221ZG0801	PACKING, CARBURETOR	1	
16#	938920401218	SCREW 4X12	1	
19#	950030502131	TUBE, VINYL 3.5X6.5X100	1	
20#	99101ZG00580	MAIN JET #58	1	
21#	99204ZE00350	PILOT JET SET #35	1	
22#	90602921000	CLIP, TUBE	1	

# HONDA GX100UKRB5 ENGINE — AIR CLEANER ASSY.

---

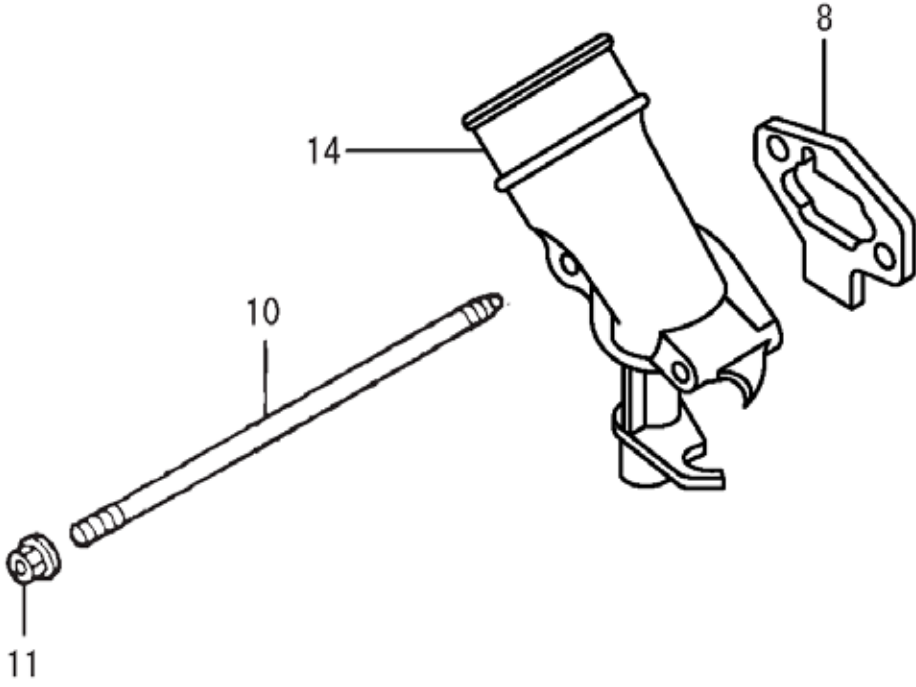

## HONDA GX100UKRB5 ENGINE — AIR CLEANER ASSY.

---

<u>NO.</u>	<u>PART NO.</u>	<u>PART NAME</u>	<u>QTY.</u>	<u>REMARKS</u>
8	17228Z0DV21	PACKING, AIR CLEANER	1	
10	90042Z4ES30	STUD BOLT 5X95	2	
11	9405005000	FLANGE NUT 5MM	2	
14	17410Z0DS00	ELBOW, AIR CLEANER	1	

# HONDA GX100UKRB5 ENGINE — MUFFLER ASSY.

---

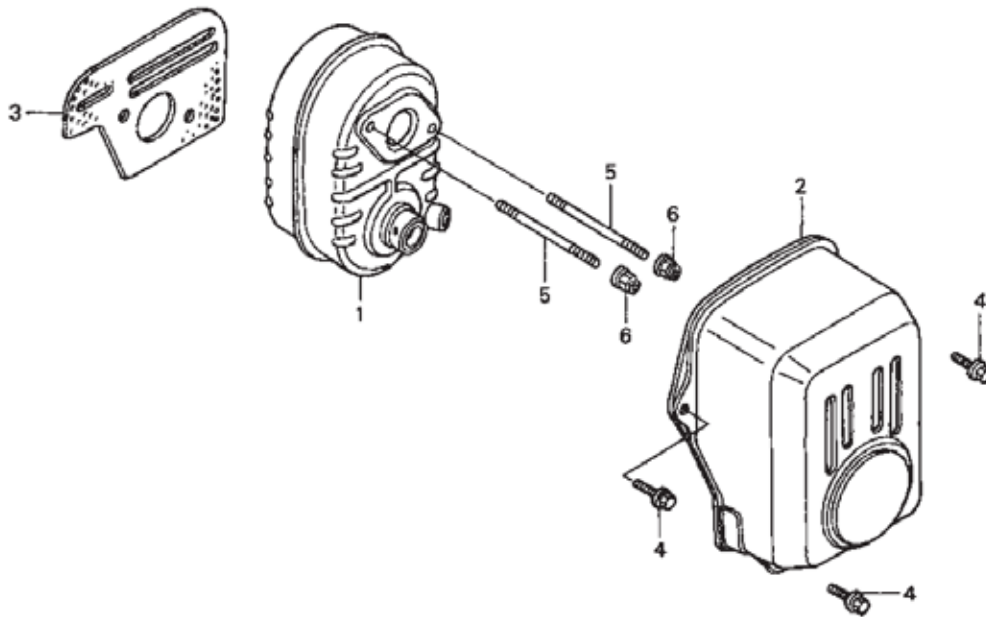



## HONDA GX100UKRB5 ENGINE — MUFFLER ASSY.

---

<u>NO.</u>	<u>PART NO.</u>	<u>PART NAME</u>	<u>QTY.</u>	<u>REMARKS</u>
1	18310Z0DV20	MUFFLER COMP.	1	
2	18321Z0DV22	MUFFLER PROTECTOR	1	
3	18381Z0D000	GASKET, MUFFLER	1	
4	90014952000	VOLT, FLANGE 6X14 (CT200)	3	
5	90048Z0DV00	STUD BOLT 6X78	2	
6	90343ZE6000	NUT, SELF-LOCK 6MM	2	

# HONDA GX100UKRB5 ENGINE — FLYWHEEL IGNITION ASSY.

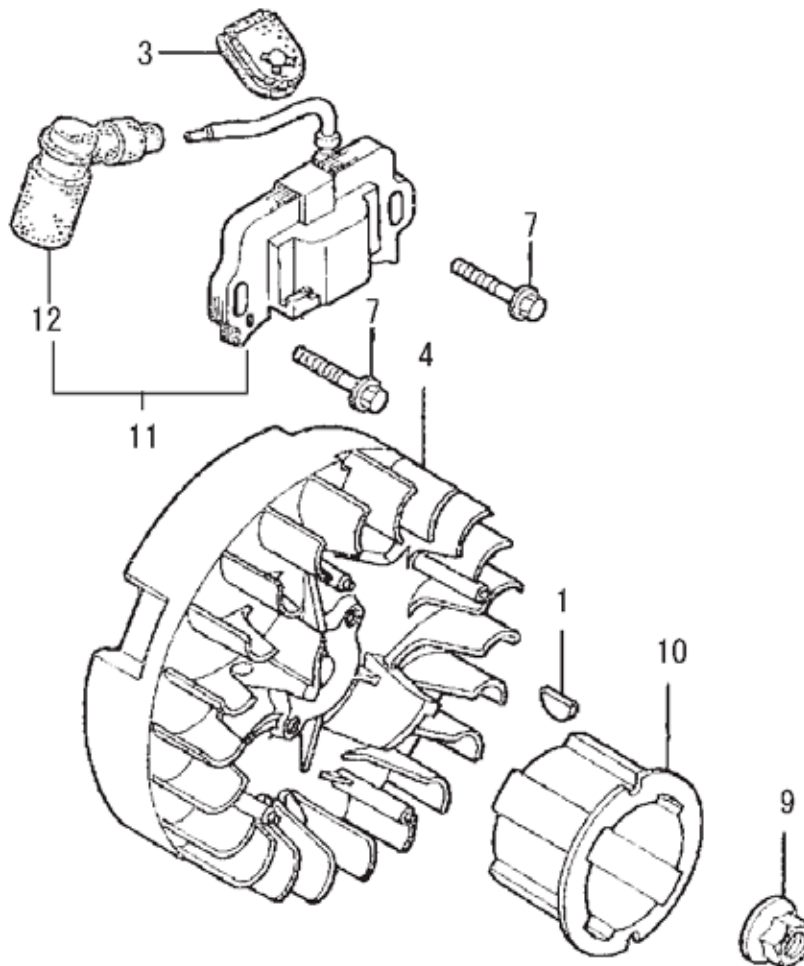

## **HONDA GX100UKRB5 ENGINE — FLYWHEEL IGNITION ASSY.**

---

<u>NO.</u>	<u>PART NO.</u>	<u>PART NAME</u>	<u>QTY.</u>	<u>REMARKS</u>
1	13331ZM7000	WOODRUFF KEY 25X18	1	
3	30564ZA5000	GROMMET, CORD	1	
4	31110Z0D003	FLYWHEEL COMP.	1	
7	90022888010	FLANGE BOLT 6X20	2	
9	9405012000	FLANGE NUT M12	1	
10	28451Z0DV03	STARTER PULLEY	1	
11	30500Z0DV02	IGNITION COIL ASSY	1	INCLUDES ITEMS W/ #
12#	30700Z0DV01	TERMINAL ASSY.	1	

# HONDA GX100UKRB5 ENGINE — CONTROL ASSY.

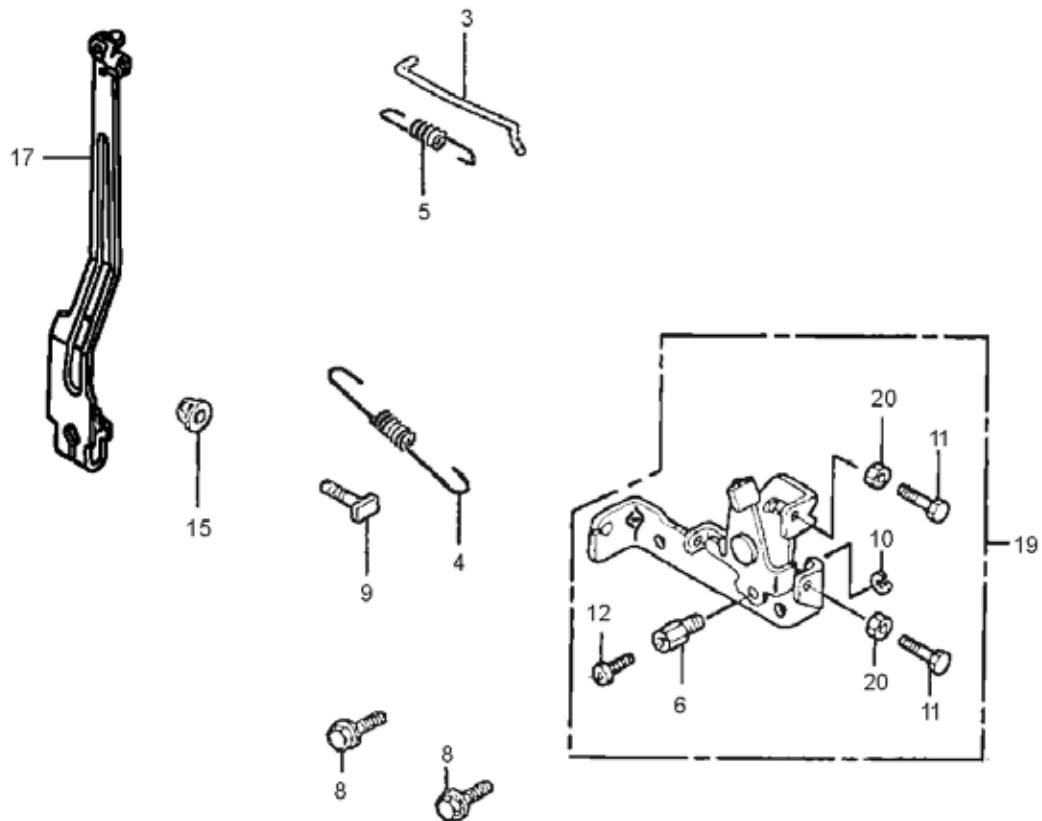

## HONDA GX100UKRB5 ENGINE — CONTROL ASSY.

<u>NO.</u>	<u>PART NO.</u>	<u>PART NAME</u>	<u>QTY.</u>	<u>REMARKS</u>
3	16555Z0DV20	GOVERNOR ROD	1	
4	16561Z0DV20	GOVERNOR SPRING	1	
5	16562Z0DV20	SPRING, THROTTLE RETURN	1	
6#	16594883010	HOLDER, WIRE	1	
8	90014952000	BOLT, FLANGE 6X14 (CT200)	2	
9	90015ZE5010	BOLT, GOVERNOR ARM	1	
10#	90605230000	CIR CLIP	1	
11#	92301050200A	BOLT 5X20	1	
12#	93500040060H	SCREW 4X6	1	
15	9405006000	FLANGE NUT 6MM	1	
17	16550Z0DV21	GOVERNOR ARM	1	
19	16500Z4ES30	CONTROL ASSY .....	1.....	INCLUDES ITEMS W/ #
20#	9400105000	NUT M5	2	

# HONDA GX100UKRB5 ENGINE — LABELS ASSY.

---

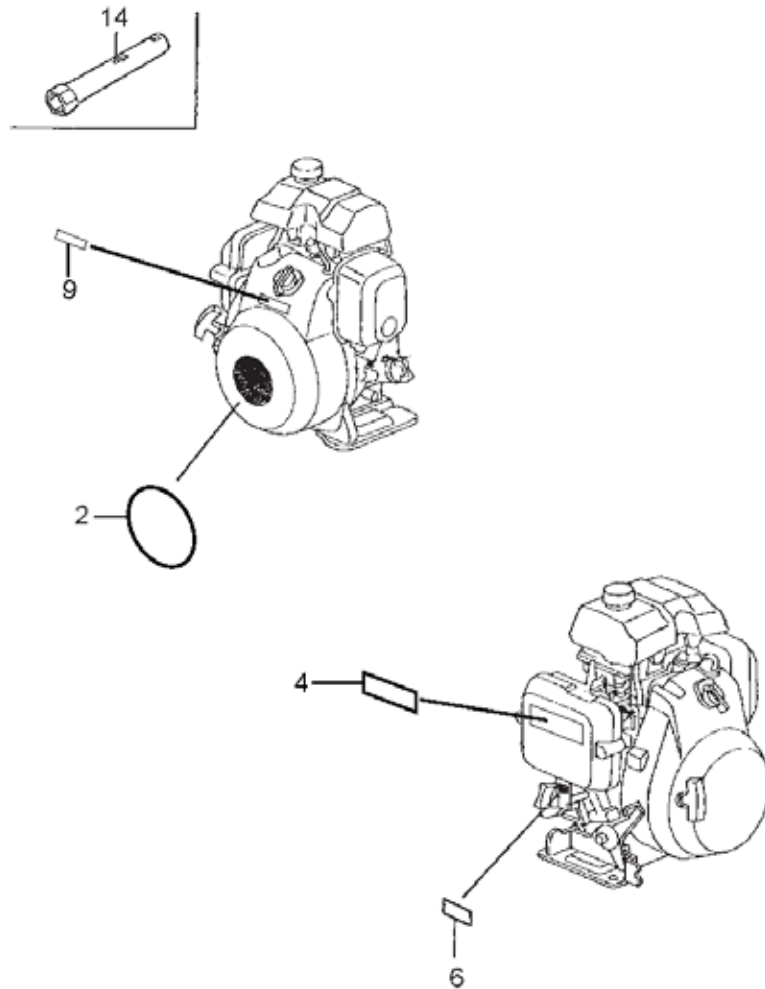

## HONDA GX100UKRB5 ENGINE — LABELS ASSY.

---

<u>NO.</u>	<u>PART NO.</u>	<u>PART NAME</u>	<u>QTY.</u>	<u>REMARKS</u>
2	87521Z0DV02	LABEL, TRADE MARK	1	
4	87516Z0J000	MARK, OPERATOR CAUTION	1	
6	87601Z4EW50	MARK, TYPE (KRBF)	1	
9	87539Z0J000	MARK, EX. CAUTION	1	
14	89216130690	WRENCH, SPARK PLUG	1	

# TERMS AND CONDITIONS OF SALE — PARTS

## PAYMENT TERMS

Terms of payment for parts are net 30 days.

## FREIGHT POLICY

All parts orders will be shipped collect or prepaid with the charges added to the invoice. All shipments are F.O.B. point of origin. Multiquip's responsibility ceases when a signed manifest has been obtained from the carrier, and any claim for shortage or damage must be settled between the consignee and the carrier.

## MINIMUM ORDER

The minimum charge for orders from Multiquip is \$15.00 net. Customers will be asked for instructions regarding handling of orders not meeting this requirement.

## RETURNED GOODS POLICY

Return shipments will be accepted and credit will be allowed, subject to the following provisions:

1. A Returned Material Authorization must be approved by Multiquip prior to shipment.
2. To obtain a Return Material Authorization, a list must be provided to Multiquip Parts Sales that defines item numbers, quantities, and descriptions of the items to be returned.
  - a. The parts numbers and descriptions must match the current parts price list.
  - b. The list must be typed or computer generated.
  - c. The list must state the reason(s) for the return.
  - d. The list must reference the sales order(s) or invoice(s) under which the items were originally purchased.
  - e. The list must include the name and phone number of the person requesting the RMA.
3. A copy of the Return Material Authorization must accompany the return shipment.
4. Freight is at the sender's expense. All parts must be returned freight prepaid to Multiquip's designated receiving point.

5. Parts must be in new and resalable condition, in the original Multiquip package (if any), and with Multiquip part numbers clearly marked.
6. The following items are not returnable:
  - a. Obsolete parts. (If an item is in the price book and shows as being replaced by another item, it is obsolete.)
  - b. Any parts with a limited shelf life (such as gaskets, seals, "O" rings, and other rubber parts) that were purchased more than six months prior to the return date.
  - c. Any line item with an extended dealer net price of less than \$5.00.
  - d. Special order items.
  - e. Electrical components.
  - f. Paint, chemicals, and lubricants.
  - g. Decals and paper products.
  - h. Items purchased in kits.
7. The sender will be notified of any material received that is not acceptable.
8. Such material will be held for five working days from notification, pending instructions. If a reply is not received within five days, the material will be returned to the sender at his expense.
9. Credit on returned parts will be issued at dealer net price at time of the original purchase, less a 15% restocking charge.
10. In cases where an item is accepted, for which the original purchase document can not be determined, the price will be based on the list price that was effective twelve months prior to the RMA date.
11. Credit issued will be applied to future purchases only.

## PRICING AND REBATES

Prices are subject to change without prior notice. Price changes are effective on a specific date and all orders received on or after that date will be billed at the revised price. Rebates for price declines and added charges for price increases will not be made for stock on hand at the time of any price change.

Multiquip reserves the right to quote and sell direct to Government agencies, and to Original Equipment Manufacturer accounts who use our products as integral parts of their own products.

## SPECIAL EXPEDITING SERVICE

A \$35.00 surcharge will be added to the invoice for special handling including bus shipments, insured parcel post or in cases where Multiquip must personally deliver the parts to the carrier.

## LIMITATIONS OF SELLER'S LIABILITY

Multiquip shall not be liable hereunder for damages in excess of the purchase price of the item with respect to which damages are claimed, and in no event shall Multiquip be liable for loss of profit or good will or for any other special, consequential or incidental damages.

## LIMITATION OF WARRANTIES

No warranties, express or implied, are made in connection with the sale of parts or trade accessories nor as to any engine not manufactured by Multiquip. Such warranties made in connection with the sale of new, complete units are made exclusively by a statement of warranty packaged with such units, and Multiquip neither assumes nor authorizes any person to assume for it any other obligation or liability whatever in connection with the sale of its products. Apart from such written statement of warranty, there are no warranties, express, implied or statutory, which extend beyond the description of the products on the face hereof.

Effective: February 22, 2006





# OPERATION AND PARTS MANUAL

## HERE'S HOW TO GET HELP

PLEASE HAVE THE MODEL AND SERIAL  
NUMBER ON-HAND WHEN CALLING

### UNITED STATES

#### ***Multiquip Corporate Office***

18910 Wilmington Ave.  
Carson, CA 90746  
Contact: mq@multiquip.com

Tel. (800) 421-1244  
Fax (800) 537-3927

#### ***MQ Parts Department***

800-427-1244  
310-537-3700

Fax: 800-672-7877  
Fax: 310-637-3284

#### ***Service Department***

800-421-1244  
310-537-3700

Fax: 310-537-4259

#### ***Warranty Department***

800-421-1244  
310-537-3700

Fax: 310-943-2249

#### ***Technical Assistance***

800-478-1244

Fax: 310-943-2238

### MEXICO

#### ***MQ Cipsa***

Carr. Fed. Mexico-Puebla KM 126.5  
Momoxpan, Cholula, Puebla 72760 Mexico  
Contact: pmastretta@cipsa.com.mx

Tel: (52) 222-225-9900  
Fax: (52) 222-285-0420

### UNITED KINGDOM

#### ***Multiquip (UK) Limited Head Office***

Unit 2, Northpoint Industrial Estate,  
Globe Lane,  
Dukinfield, Cheshire SK16 4UJ  
Contact: sales@multiquip.co.uk

Tel: 0161 339 2223  
Fax: 0161 339 3226

### CANADA

#### ***Multiquip***

4110 Industriel Boul.  
Laval, Quebec, Canada H7L 6V3  
Contact: jmartin@multiquip.com

Tel: (450) 625-2244  
Tel: (877) 963-4411  
Fax: (450) 625-8664

© COPYRIGHT 2012, MULTIQUIP INC.

Multiquip Inc, the MQ logo and the Mikasa logo are registered trademarks of Multiquip Inc. and may not be used, reproduced, or altered without written permission. All other trademarks are the property of their respective owners and used with permission.

This manual MUST accompany the equipment at all times. This manual is considered a permanent part of the equipment and should remain with the unit if resold.

The information and specifications included in this publication were in effect at the time of approval for printing. Illustrations, descriptions, references and technical data contained in this manual are for guidance only and may not be considered as binding. Multiquip Inc. reserves the right to discontinue or change specifications, design or the information published in this publication at any time without notice and without incurring any obligations.

Your Local Dealer is:



## Free Manuals Download Website

<http://myh66.com>

<http://usermanuals.us>

<http://www.somanuals.com>

<http://www.4manuals.cc>

<http://www.manual-lib.com>

<http://www.404manual.com>

<http://www.luxmanual.com>

<http://aubethermostatmanual.com>

Golf course search by state

<http://golfingnear.com>

Email search by domain

<http://emailbydomain.com>

Auto manuals search

<http://auto.somanuals.com>

TV manuals search

<http://tv.somanuals.com>