

# OPERATION AND PARTS MANUAL



## **MODEL QP4TZ TRASH PUMP (Hatz 1B40U-2203A DIESEL ENGINE)**

Revision #1 (10/10/08)

To find the latest revision of this  
publication, visit our website at:  
[www.multiquip.com](http://www.multiquip.com)



**THIS MANUAL MUST ACCOMPANY THE EQUIPMENT AT ALL TIMES.**



**WARNING**



**CALIFORNIA — Proposition 65 Warning**

Diesel engine exhaust and some of its constituents are known to the State of California to cause cancer, birth defects and other reproductive harm.



**MQ QP4TZ Trash Pump**

Proposition 65 Warning ..... 2  
 Table of Contents ..... 4  
 Parts Ordering Procedures ..... 5  
 Safety Information ..... 6-10  
 Pump Specifications/Dimensions ..... 12  
 Engine Specifications ..... 13  
 General Information ..... 14  
 Pump Components ..... 15  
 Refueling ..... 16  
 Basic Engine ..... 17  
 Inspection (Engine) ..... 18  
 Setup (Pump) ..... 19  
 Operation ..... 20-21  
 Maintenance (Pump) ..... 22-23  
 Maintenance (Engine) ..... 24-25  
 Preparation for Long-Term Storage ..... 26  
 Troubleshooting (Engine) ..... 27  
 Troubleshooting (Pump) ..... 28  
 Explanation Of Code In Remarks Column ..... 30  
 Suggested Spare Parts ..... 31  
 Pump Assy. .... 32-35

**Hatz 1B40U-2203A  
 Diesel Engine**

Spare Parts Kit Assembly ..... 36-37  
 Crankcase Assembly ..... 38-39  
 Compensation of Masses ..... 40-41  
 Crankshaft Assembly ..... 42-43  
 Camshaft Assembly ..... 44-45  
 Piston, Conrod, Cylinder Assembly ..... 46-47  
 Cylinder Head Assembly ..... 48-49  
 Oil Pump/Governor Assembly ..... 50-53  
 Timing Cover Assembly ..... 54-57  
 Blower and Flywheel Assembly ..... 58-59  
 Injection Equipment Assembly ..... 60-63  
 Recoil Starter Assembly ..... 64-65  
 Air Duct Assembly (A) ..... 66-67  
 Air Duct Assembly (B) ..... 68-69  
 Crankcase Breathing Assembly ..... 70-71  
 Fuel Tank Assembly ..... 72-75  
 Air Filter Assembly ..... 76-77  
 Exhaust Silencer Assembly ..... 78-79  
 Starter, Alternator Assembly ..... 80-81  
 Electric Equipment, Wiring Assembly ..... 82-83  
 Speed Control Assembly ..... 84-85  
 Engine Stop Device Assembly ..... 86-87  
 Engine Special EPA Equipment ..... 88-89

Terms and Condition Of Sale — Parts ..... 90

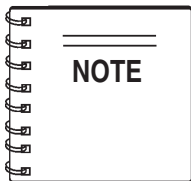

*Specification and part number  
 are subject to change without  
 notice.*

# PARTS ORDERING PROCEDURES

## Ordering parts has never been easier! Choose from three easy options:

Effective:  
January 1<sup>st</sup>, 2006

www.multiquip.com



### Order via Internet (Dealers Only):

Order parts on-line using Multiquip's SmartEquip website!

- View Parts Diagrams
- Order Parts
- Print Specification Information



If you have an MQ Account, to obtain a Username and Password, E-mail us at: [parts@multiquip.com](mailto:parts@multiquip.com).

To obtain an MQ Account, contact your District Sales Manager for more information.

Goto [www.multiquip.com](http://www.multiquip.com) and click on **Order Parts** to log in and save!

Use the **internet** and qualify for a **5% Discount** on *Standard orders* for all orders which include complete part numbers.\*

Note: Discounts Are Subject To Change



### Order via Fax (Dealers Only):

All customers are welcome to order parts via Fax.

**Domestic (US) Customers dial:**  
1-800-6-PARTS-7 (800-672-7877)

**Fax** your order in and qualify for a **2% Discount** on *Standard orders* for all orders which include complete part numbers.\*

Note: Discounts Are Subject To Change



**Order via Phone: Domestic (US) Dealers Call:**  
1-800-427-1244

### Non-Dealer Customers:

Contact your local Multiquip Dealer for parts or call 800-427-1244 for help in locating a dealer near you.



**International Customers** should contact their local Multiquip Representatives for Parts Ordering information.

## When ordering parts, please supply:

- |   |  |
|---|--|
| <input type="checkbox"/> Dealer Account Number                                | <input type="checkbox"/> Specify Preferred Method of Shipment: |
| <input type="checkbox"/> Dealer Name and Address                              | ✓ UPS/Fed Ex                      ✓ DHL                        |
| <input type="checkbox"/> Shipping Address (if different than billing address) | ■ Priority One                      ✓ Truck                    |
| <input type="checkbox"/> Return Fax Number                                    | ■ Ground   |
| <input type="checkbox"/> Applicable Model Number                              | ■ Next Day   |
| <input type="checkbox"/> Quantity, Part Number and Description of Each Part   | ■ Second/Third Day   |

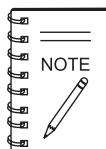

All orders are treated as *Standard Orders* and will ship the same day if received prior to 3PM PST.

WE ACCEPT ALL MAJOR CREDIT CARDS!



# SAFETY INFORMATION

Do not operate or service the equipment before reading the entire manual. Safety precautions should be followed at all times when operating this equipment. Failure to read and understand the safety messages and operating instructions could result in injury to yourself and others.



## SAFETY MESSAGES

The four safety messages shown below will inform you about potential hazards that could injure you or others. The safety messages specifically address the level of exposure to the operator and are preceded by one of four words: **DANGER**, **WARNING**, **CAUTION** or **NOTICE**.

## SAFETY SYMBOLS

**! DANGER**

Indicates a hazardous situation which, if not avoided, **WILL** result in **DEATH** or **SERIOUS INJURY**.

**! WARNING**

Indicates a hazardous situation which, if not avoided, **COULD** result in **DEATH** or **SERIOUS INJURY**.







**! CAUTION**

Indicates a hazardous situation which, if not avoided, **COULD** result in **MINOR** or **MODERATE INJURY**.

**NOTICE**

Addresses practices not related to personal injury.

Potential hazards associated with the operation of this equipment will be referenced with hazard symbols which may appear throughout this manual in conjunction with safety messages.

Symbol	Safety Hazard
	Lethal exhaust gas hazards
	Explosion hazards
	Burn hazards
	Pressurized fluid hazards
	Battery acid hazards
	Eye safety hazards

## GENERAL SAFETY

### CAUTION

- **NEVER** operate this equipment without proper protective clothing, shatterproof glasses, respiratory protection, hearing protection, steel-toed boots and other protective devices required by the job or city and state regulations.



- **NEVER** operate this equipment when not feeling well due to fatigue, illness or when under medication.



- **NEVER** operate this equipment under the influence of drugs or alcohol.



### NOTICE

- This equipment should only be operated by trained and qualified personnel 18 years of age and older.
- Whenever necessary, replace nameplate, operation and safety decals when they become difficult read.
- Manufacturer does not assume responsibility for any accident due to equipment modifications. Unauthorized equipment modification will void all warranties.
- **NEVER** use accessories or attachments that are not recommended by Multiquip for this equipment. Damage to the equipment and/or injury to user may result.
- **ALWAYS** know the location of the nearest fire extinguisher.
- **ALWAYS** know the location of the nearest first aid kit.
- **ALWAYS** know the location of the nearest phone or **keep a phone on the job site**. Also, know the phone numbers of the nearest **ambulance, doctor** and **fire department**. This information will be invaluable in the case of an emergency.



## PUMP SAFETY

### DANGER

- **NEVER** pump volatile, explosive, flammable or low flash point fluids. These fluids could ignite or explode.
- The engine fuel exhaust gases contain poisonous carbon monoxide. This gas is colorless and odorless, and can cause death if inhaled.
- The engine of this equipment requires an adequate free flow of cooling air. **NEVER** operate this equipment in any enclosed or narrow area where free flow of the air is restricted. If the air flow is restricted it will cause injury to people and property and serious damage to the equipment or engine.



- **NEVER** operate the equipment in an explosive atmosphere or near combustible materials. An explosion or fire could result causing severe **bodily harm or even death**.



### WARNING

- **NEVER** pump corrosive chemicals or water containing toxic substances. These fluids could create serious health and environmental hazards. Contact local authorities for assistance.
- **NEVER** open the priming plug when pump is hot. Hot water inside could be pressurized much like the radiator of an automobile. Allow pump to cool to the touch before loosening plug. The possibility exists of scalding, resulting in severe bodily harm.
- **NEVER** disconnect any **emergency or safety devices**. These devices are intended for operator safety. Disconnection of these devices can cause severe injury, bodily harm or even death. Disconnection of any of these devices will void all warranties.



## CAUTION

- **NEVER** lubricate components or attempt service on a running machine.
- **NEVER** block or restrict flow from discharge hose. Remove kinks from discharge line before starting pump. Operation with a blocked discharge line can cause water inside pump to overheat.

## NOTICE

- **ALWAYS** fill the pump casing with water before starting the engine. Failure to maintain water inside the pump housing will cause severe damage to the pump and mechanical seal.
- In winter drain water from pump housing to prevent freezing.
- **NEVER** start the pump with the clean-out cover removed. The rotating impeller inside the pump can cut or sever objects caught in it. Before starting the pump, check that the clean-out cover is securely fastened.
- **ALWAYS** keep the machine in proper running condition.
- **ALWAYS** ensure pump is on level ground before use.
- Fix damage to machine and replace any broken parts immediately.
- **ALWAYS** store equipment properly when it is not being used. Equipment should be stored in a clean, dry location out of the reach of children and unauthorized personnel.

## ENGINE SAFETY

### WARNING

- **NEVER** operate the engine with heat shields or guards removed.
- **DO NOT** remove the engine oil drain plug while the engine is hot. Hot oil will gush out of the oil tank and severely scald any persons in the general area of the pump.



### CAUTION

- **NEVER** touch the hot exhaust manifold, muffler or cylinder. Allow these parts to cool before servicing equipment.



### NOTICE

- **NEVER** run engine without an air filter or with a dirty air filter. Severe engine damage may occur. Service air filter frequently to prevent engine malfunction.
- **NEVER** tamper with the factory settings of the engine or engine governor. Damage to the engine or equipment can result if operating in speed ranges above the maximum allowable.







## FUEL SAFETY

### DANGER

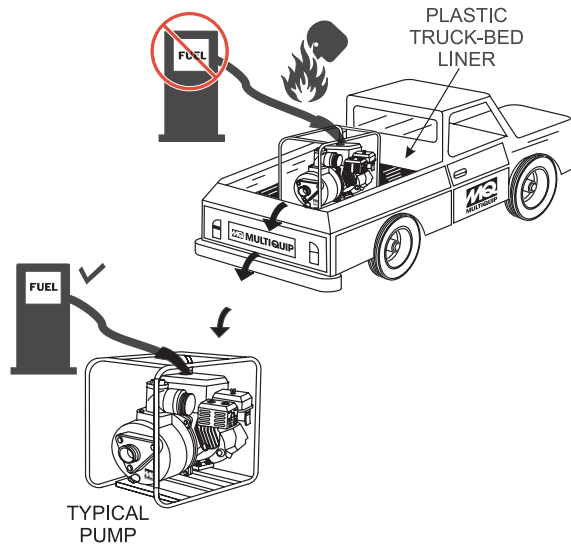
- **DO NOT** add fuel to equipment if it is placed inside truck bed with plastic liner. Possibility exists of explosion or fire due to static electricity.





- **DO NOT** start the engine near spilled fuel or combustible fluids. Fuel is extremely flammable and its vapors can cause an explosion if ignited.
- **ALWAYS** refuel in a well-ventilated area, away from sparks and open flames.
- **ALWAYS** use extreme caution when working with **flammable** liquids.
- **DO NOT** fill the fuel tank while the engine is running or hot.
- **DO NOT** overfill tank, since spilled fuel could ignite if it comes into contact with hot engine parts or sparks from the ignition system.
- Store fuel in appropriate containers, in well-ventilated areas and away from sparks and flames.
- **NEVER** use fuel as a cleaning agent.
- **DO NOT** smoke around or near the equipment. Fire or explosion could result from fuel vapors or if fuel is spilled on a hot engine. 

## BATTERY SAFETY (ELECTRIC START ONLY)

### DANGER

- **DO NOT** drop the battery. There is a possibility that the battery will explode.
- **DO NOT** expose the battery to open flames, sparks, cigarettes, etc. The battery contains combustible gases and liquids. If these gases and liquids come into contact with a flame or spark, an explosion could occur. 

### WARNING

- **ALWAYS** wear safety glasses when handling the battery to avoid eye irritation. The battery contains acids that can cause injury to the eyes and skin. 
- Use well-insulated gloves when picking up the battery.
- **ALWAYS** keep the battery charged. If the battery is not charged, combustible gas will build up.
- **DO NOT** charge battery if frozen. Battery can explode. When frozen, warm the battery to at least 61°F (16°C).
- **ALWAYS** recharge the battery in a well-ventilated environment to avoid the risk of a dangerous concentration of combustible gases.
- If the battery liquid (dilute sulfuric acid) comes into contact with **clothing or skin**, rinse skin or clothing immediately with plenty of water. 
- If the battery liquid (dilute sulfuric acid) comes into contact with **eyes**, rinse eyes immediately with plenty of water and contact the nearest doctor or hospital to seek medical attention.

### CAUTION

- **ALWAYS** disconnect the **NEGATIVE** battery terminal before performing service on the equipment.
- **ALWAYS** keep battery cables in good working condition. Repair or replace all worn cables.

## TRANSPORTING SAFETY

### ⚠ CAUTION

- **NEVER** allow any person or animal to stand underneath the equipment while lifting.

### NOTICE

- Before lifting, make sure that the equipment parts (hook and vibration insulator) are not damaged and screws are not loose or missing.
- Always make sure crane or lifting device has been properly secured to the lifting bail (hook) of the equipment.
- **ALWAYS** shutdown engine before transporting.
- **NEVER** lift the equipment while the engine is running.
- Tighten fuel tank cap securely and close fuel cock to prevent fuel from spilling.
- Use adequate lifting cable (wire or rope) of sufficient strength.
- Use one point suspension hook and lift straight upwards.

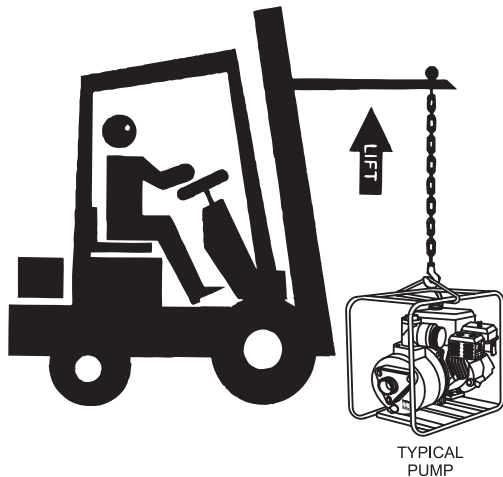

- **DO NOT** lift machine to unnecessary heights.
- **ALWAYS** tie down equipment during transport by securing the equipment with rope.

## ENVIRONMENTAL SAFETY

### NOTICE

- Dispose of hazardous waste properly. Examples of potentially hazardous waste are used motor oil, fuel and fuel filters. 
- **DO NOT** use food or plastic containers to dispose of hazardous waste.
- **DO NOT** pour waste, oil or fuel directly onto the ground, down a drain or into any water source.



# SPECIFICATIONS/DIMENSIONS (PUMP)

**Table 1. Specifications (Pump)**

<b>Pump</b>	<b>Model</b>	<b>QP- 4TZ</b>
	Type	Trash Pump
	Suction X Discharge Size	4 x 4 in. (100 x 100 mm.)
	Maximum Pumping Capacity	526 gallons/minute (2000 liters/minute)
	Max. Solids Diameter	1.50 in. (38 mm.)
	Max. Lift	25 ft. (7.62 meters)
	Max. Head	85 ft. (26 meters)
<b>Dimension (L x W x H)</b>	30.1 x 27.3 X 30.7 in. (765 X 695 X 780 mm.)	
<b>Dry Net Weight</b>	265 lbs. (120 Kg.)	

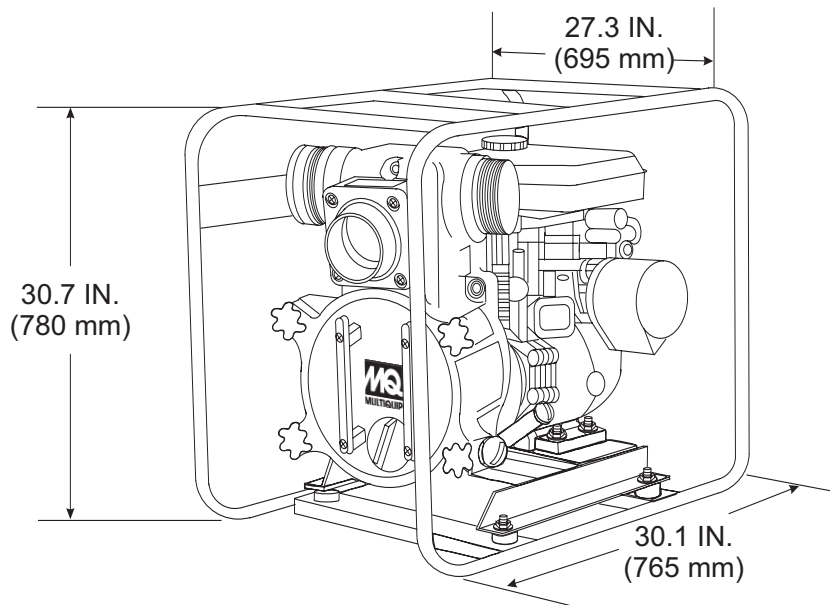
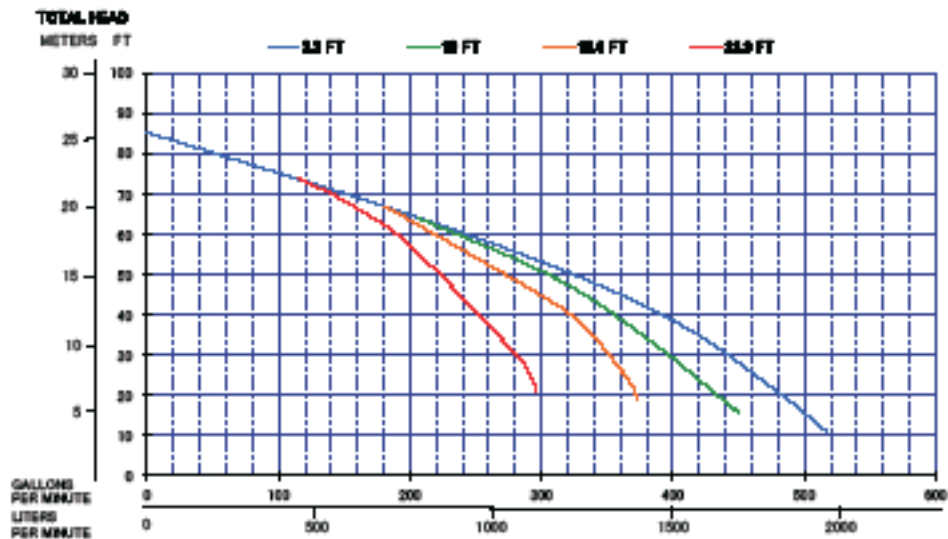

**Figure 1. QP4TZ Dimensions**

# SPECIFICATIONS (ENGINE)

**Table 2. Engine Specifications**

Engine Make	HATZ 1B40U-2203A
Engine Type	Air-Cooled, 4-Stroke, Single Cylinder, Diesel Engine
Cylinder Bore X Stroke	3.5 x 3 in (88 x 76 mm)
Displacement	29 cu in (462 cm <sup>3</sup> )
Maximum Output	9.9 HP @3,600 RPM (7.4 kw @3600 RPM)
Fuel Tank Capacity	5.2 quarts (6.5 liters)
Oil Capacity	1.6 quartz (1.5 liters)
Starting Method	Electric/Recoil Start
Dry Net Weight	121.25 lbs. (55 kg)



**QP4TZ Performance Curves**

## APPLICATION

The **QP4TZ Trash Pump** is designed to be used for dewatering applications. Both the suction and discharge ports on the QP4TZ trash pump use a 4-inch diameter opening, which allows the pump to pump at a rate of approximately 526 gallons/minute (gpm) or 2,000 liters/minute (lpm).

Trash or self-priming pumps are designed to purge air from the suction line and create a partial vacuum in the pump body. The reduced atmospheric pressure inside the pump allows water to flow through the suction line and into the pump body. The centrifugal force created by the rotating impeller pressurizes the water and expels it from the pump.

## Engine

This trash pump is powered by a 9.9 horsepower, air-cooled, **HATZ 1B40** diesel engine.

## Trash Pump

Trash pumps derive their name from their ability to handle a greater amount of debris and solids than standard centrifugal pumps. This pump generally handle solids up to 1/2 the size of the discharge opening making them less likely to clog. Also trash pumps are capable of handling water with 25% solids by weight.

The advantage of using a trash pump is that it can be quickly and easily disassembled in the field "**without tools**" and easily cleaned when clogged.

## Suction Lift

This pump is intended to be used for dewatering applications and is capable of suction lifts up to 25 feet at sea level. For optimal suction lift performance, keep the suction hose or line as short as possible. In general, always place the pump as close to the water as possible.

## Pump Support

The pump should always be placed on **solid stationary ground** in a level position.

**NEVER** place the pump on **soft soil**. The suction hose or pipe connection should always be checked for tightness and leaks. A small suction leak in the hose or fittings could prevent the pump from priming.

## Elevation

Higher elevations will effect the performance of the pump. Due to less atmospheric pressure at higher altitudes, pumps **DO NOT** have the priming ability that they have at sea level. This is due to the "thinner air" or lack of oxygen at higher altitudes.

A general rule of thumb is that for every 1,000 feet of elevation above sea level a pump will lose one foot of priming ability.

For example, in Flagstaff, Arizona where the elevation is approximately 7,000 feet, the pump would have a suction lift of 25 feet rather than the 18 feet at sea level. Table 3 shows suction lift at various elevations.

**Table 3. Suction Lift at Various Elevations**

Altitude Feet (Meters)	Suction Lift in Feet (Meters)			
	Sea Level	10.0 (3.048)	15.0 (4.572)	20.0 (6.096)
2,000 (610)	8.80 (2.680)	13.2 (4.023)	17.6 (5.364)	22.0 (6.705)
4,000 (1,219)	7.80 (2.377)	11.7 (3.566)	15.6 (4.754)	19.5 (5.943)
6,000 (1,829)	6.90 (2.103)	10.4 (3.169)	13.8 (4.206)	17.3 (5.273)
8,000 (2,438)	6.20 (1.889)	9.30 (2.834)	12.4 (3.779)	15.5 (4.724)
10,000 (3,048)	5.70 (1.737)	8.60 (2.621)	11.4 (3.474)	14.3 (4.358)

Table 4 shows percentage drops in performance as elevation increases.

**Table 4. Performance Loss at Various Elevations**

Altitude Feet (Meters)	Discharge Flow	Discharge Head
Sea Level	100%	100%
2,000 (610)	97%	95%
4,000 (1,219)	95%	91%
6,000 (1,829)	93%	87%
8,000 (2,438)	91%	83%
10,000 (3,048)	88%	78%

Figure 2 shows a typical application using the QP4TZ Trash pump. Please note that this pump is intended for the removal of clean water and water containing some debris and solids. Maximum size of solids should not exceed 1.5 inch (30 mm) in diameter. **DO NOT** set strainer on bottom of water bed. Placing the strainer above the water bed will prevent the pump from drawing in excessive amounts of sand and foreign debris.

**Figure 2. QP- 4TZ Pump Application**

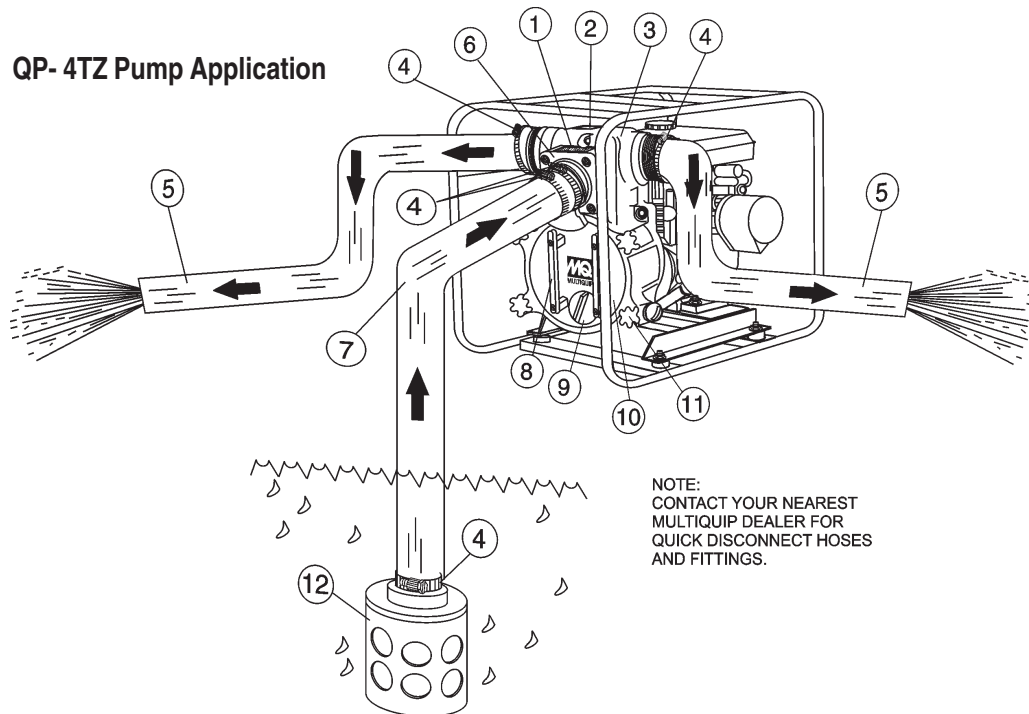

NOTE:  
CONTACT YOUR NEAREST  
MULTIQUIP DEALER FOR  
QUICK DISCONNECT HOSES  
AND FITTINGS.

1. **Pump** – The model QP4TZ is a 4-inch trash pump used in general dewatering applications. Typical dewatering applications consist of manholes, septic tanks, fast and slow seepage ditch water, silt water, mud water and muck water.
2. **Fill Cap** – Prior to operation, the pump casing should be filled with water. Remove this cap to add water to the pump. After the initial prime, a sufficient amount of water will be retained in the casing so that the operator will not need to re-prime later.  
If the casing is dry or has insufficient water, the pump will have difficulty in priming which could lead to premature mechanical seal wear thus causing damage to the pump.
3. **Discharge Port** – Connect a 4-inch discharge hose to either port (one of two ports).
4. **Worm Clamp** – Used to secure the hose to the inlet and outlet ports on the pump. Use two clamps to secure the hose on the inlet side of the pump.
5. **Discharge Hose** – Connect this flexible rubber hose to the discharge port on the pump. Make sure that the hose lays flat and is not kinked. Use only recommended type discharge hose. Contact Multiquip Parts Department for ordering information.
6. **Suction Port** – Connect a 4-inch inlet hose to this port. Use two worm clamps to secure the hose.
7. **Suction Hose** – Connect this flexible rubber hose to the suction portion the pump. Make sure that the hose lays flat and is not kinked. Use only recommended type suction hose. Contact Multiquip Parts Department for ordering information.
8. **Clean-out Cover Handles** – To gain access to the pump's clean-out area, grip both handles, then pull to remove cover. Make sure both locking knobs have been released before attempting to remove clean-out cover.
9. **Drain Plug** – Remove this plug to drain water from the pump.
10. **Clean-out Cover** – Remove cover to gain access to the clean-out area.
11. **Locking Knobs** – Turn both knobs clockwise to secure clean-out cover, turn counterclockwise to release cover.
12. **Strainer** – Always attach a strainer to the bottom side of the suction hose to prevent large objects and debris from entering the pump. Strainer should be positioned so that it will remain completely under water. Running the pump with the strainer above water for long periods can damage pump.



**DANGER**

Adding fuel to the tank should be done only when the engine is stopped and has had an opportunity to cool down. In the event of a fuel spill, **DO NOT** attempt to start the engine until the fuel residue has been completely wiped up, and the area surrounding the engine is dry. If pump is placed in a truck bed with a plastic liner, **REMOVE** pump from truck bed and place on ground (Figure 3) to refuel. The possibility of **fire** or **explosion** exists, due to static electricity.

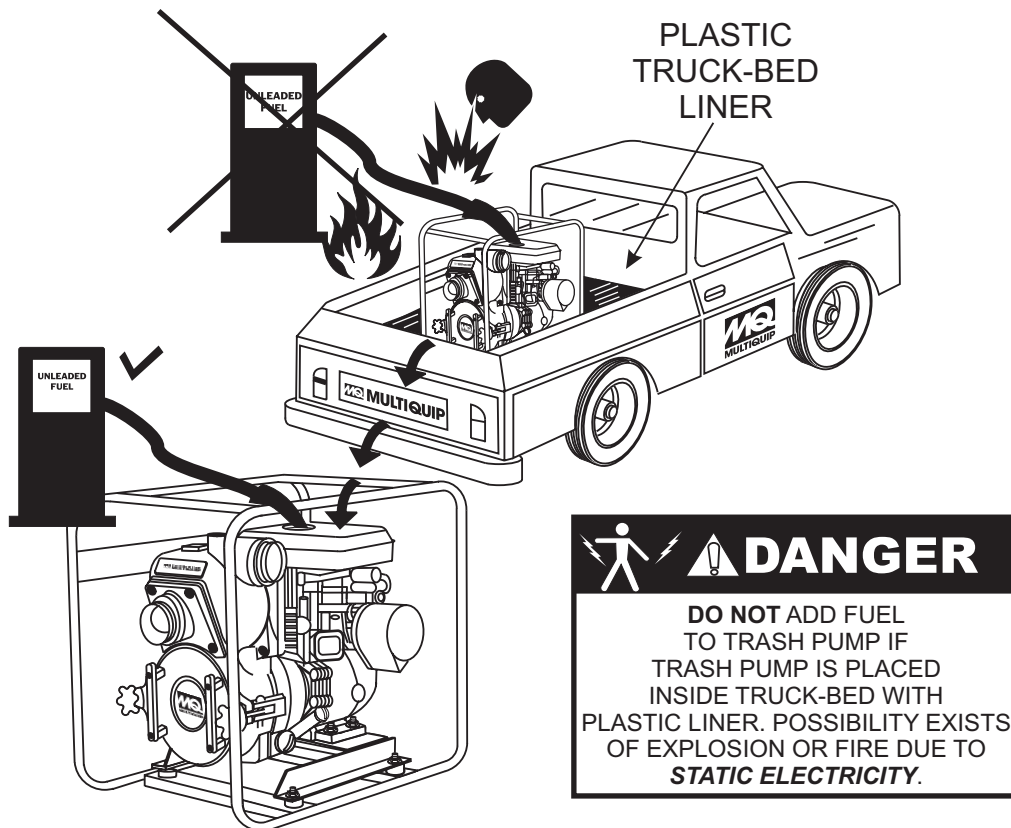
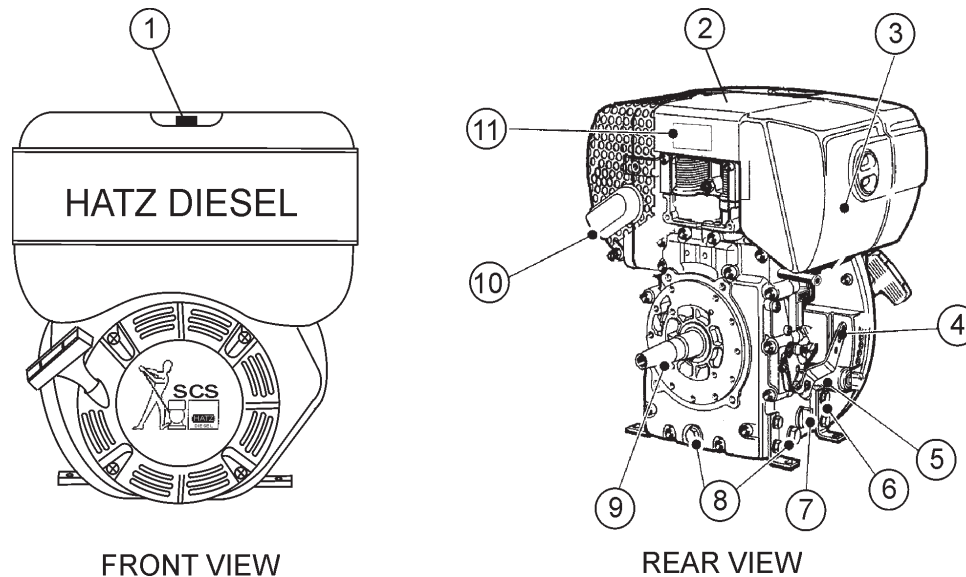

Figure 3. Pump Refueling





**Figure 4. Engine Controls and Components**

## INITIAL SERVICING

The engine (Figure 4) must be checked for proper lubrication and filled with fuel prior to operation. Refer to the manufacturer's engine manual for instructions and details of operation and servicing.

1. **Fuel Filler Cap/Fuel Tank** – Pull this latch to add **diesel** fuel to the tank. After refueling, always make sure the fuel cap is latched properly. **DO NOT** over fill. For additional information refer to engine owner's manual.



### **WARNING**

Adding fuel to the tank should be accomplished only when the engine is stopped and has had an opportunity to cool down. In the event of a fuel spill, **DO NOT** attempt to start the engine until the fuel residue has been completely wiped up, and the area surrounding the engine is dry.

2. **Engine Lifting Straps/Cover** – Remove the air cleaner cover, then lift this cover (the one with decals on it) to gain access to the engine lifting straps.
3. **Air Cleaner/Cover** – Prevents dirt and other debris from entering the fuel system. Remove wing-nut on side of air filter cover to gain access to filter element.
4. **Speed Control Lever** – This lever is connected to the throttle control which is located on the side of the engine compartment cover. Use this lever to control engine speed.
5. **Dip Stick** – Remove dipstick to determine if the engine oil level is low. If low, add oil as specified.

6. **Engine Motor Mounts** – Attach these engine mounts to the pump frame. Tighten securely.
7. **Oil Filter** – Remove this bolt to gain access (internal) to the engine oil filter. Service the oil filter as recommended in the maintenance section of this manual.
8. **Oil Drain Plugs** – There are two oil drain plugs, one is underneath the flywheel, the other on the side of the engine. Remove these plugs to drain engine oil from the engine crankcase.
9. **Crankshaft** – Connect this shaft to the input of the transmission.
10. **Muffler** – Used to reduce noise and emissions.
11. **Nameplate** – Contains information about the engine.



### **WARNING**

Engine components can generate extreme heat. To prevent burns, **DO NOT** touch these areas while the engine is running or immediately after operating. **NEVER** operate the engine with the muffler removed.

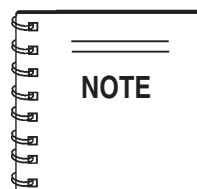

Operating the engine without an air filter, with a damaged air filter, or a filter in need of replacement will allow dirt to enter the engine, causing rapid engine wear.

## CAUTION



**NEVER** operate the pump in a confined area or enclosed area structure that does not provide ample **free flow of air**.

**ALWAYS** wear approved eye and hearing protection before operating the pump.

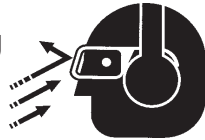

### Before Starting

1. Read safety instructions at the beginning of manual.
2. Clean the pump, removing dirt and dust, particularly the engine cooling air inlet, carburetor and air cleaner.
3. Check the air filter for dirt and dust. If air filter is dirty, replace air filter with a new one as required.
4. Check carburetor for external dirt and dust. Clean with dry compressed air.
5. Check fastening nuts and bolts for tightness.



### Engine Oil Check

1. To check the engine oil level, place the pump on secure level ground with the engine stopped.
2. Remove the filler dipstick from the engine oil filler hole (Figure 5) and wipe clean.

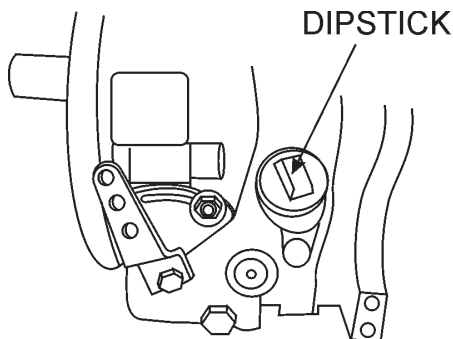

Figure 5. Engine Oil Dipstick (Removal)

3. Insert and remove the dipstick without screwing it into the filler neck. Check the oil level shown on the dipstick.
4. If the oil level is low (Figure 6), fill to the edge of the oil filler hole with the recommended oil type (Table 5). Maximum oil capacity is 1.6 quarts (1.5 liters).

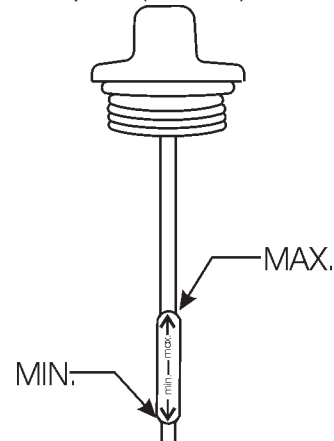

Figure 6. Engine Oil Dipstick (Oil Level)

Table 5. Oil Type

Season	Temperature	Oil Type
Summer	25°C or Higher	SAE 10W-30
Spring/Fall	25°C~10°C	SAE 10W-30/20
Winter	0°C or Lower	SAE 10W-10

## Explosive Fuel



## DANGER

Motor fuels are highly flammable and can be dangerous if mishandled. **DO NOT** smoke while refueling. **DO NOT** attempt to refuel the pump if the engine is **hot!** or **running**.

### Fuel Check

1. Remove the fuel cap located on top of fuel tank.
2. Visually inspect to see if the fuel level is low. If fuel is low, replenish with diesel fuel.
3. When refueling, be sure to use a strainer for filtration. **DO NOT** top-off fuel. Wipe up any spilled fuel **immediately!**

## Before Starting

1. Read safety instructions at the beginning of manual.
2. Place pump as near to water as possible on a firm and flat level surface.
3. To prime pump, remove fill cap (Figure 2) and fill pump casing with water. If the pump casing is not filled with water before starting, it will not begin pumping.

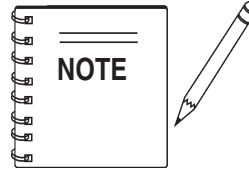

Suction and discharge hoses are available from Multiquip. Contact your nearest dealer for more information.

### CAUTION

Pump casing **must** be filled with water before using pump. Otherwise pump will not be able to begin pumping.

### WARNING

**DO NOT** open **fill cap** if pump is **hot!** Water inside may be under pressure.

4. Check for **leaks** between pump and engine. If water is leaking between the pump and engine housing, the seal inside the pump may be worn or damaged. Continued operation of the pump is not recommended. Further usage of the pump under these conditions may cause severe water damage to engine.

## Hoses and Clamps

1. Check that all hoses are **securely** attached to the pump. Make certain suction hose (Figure 2) does not have any air leakage. Tighten hose clamps and couplings as required.
2. It is recommended that 2 clamps be used when securing the suction hose to the inlet side (suction) of the pump.
3. Remember suction hoses must be **rigid** enough not to collapse when the pump is in operation.
4. Check that the **discharge** hose (Figure 2) is not restricted. Place hose so that it lays as straight as it is possible on the ground. Remove any twists or sharp bends from hose which may block the flow of water.

5. The discharge hose is usually a **collapsible** (thin-walled) hose, however if a thin-walled discharge hose is not available, a rigid suction hose can be substituted in its place.
6. Make sure the **suction strainer** (Figure 2) is clean and securely attached to the water end of the suction hose. The strainer is designed to protect the pump by preventing large objects from being pulled into the pump.

### CAUTION

The strainer should be positioned so it will remain completely **under water**. Running the pump with the strainer above water for long periods can damage the pump.

### CAUTION

**DO NOT** pump flammable fluids, corrosive chemicals or fluids containing toxic substances. These fluids can create potentially dangerous health and environmental hazards. Contact local authorities for assistance.

### CAUTION

This pump uses a water-cooled **mechanical seal** to prevent water from seeping into the engine. The passage of water through the pump casing lubricates the seal and prevents it from overheating. **NEVER!** operate the pump without water in the casing as this will cause damage to the mechanical seal.

## CAUTION



**DO NOT** attempt to operate the pump until the Safety, General Information and Inspection sections of this manual have been *read and thoroughly understood*.

This section is intended to assist the operator with the *initial start-up* of the trash pump. It is extremely important that this section be read carefully before attempting to use the pump in the field.

### Starting the Engine - Recoil Start

1. Move the speed lever control to the **START** position (Figure 8).

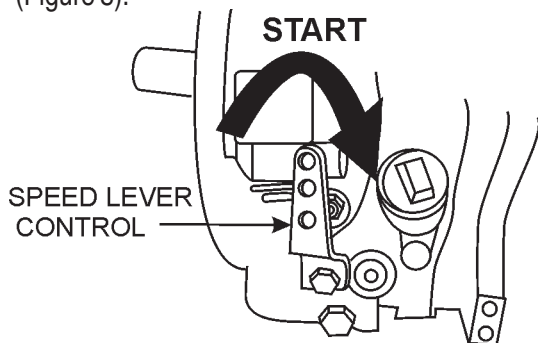

**Figure 8. Engine Speed Lever Control (START position)**

2. Grasp the starter grip (Figure 9) and slowly pull it out until you feel the strongest resistance then return the starter grip to the initial position.

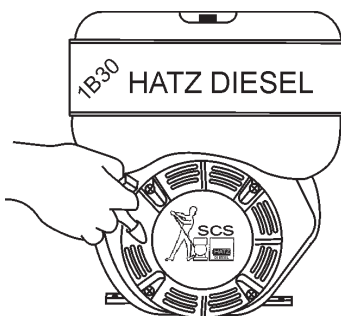

**Figure 9. Starter Grip**

## CAUTION

Do not allow the starter grip to snap back against the engine. Return it gently to prevent damage to the starter.

3. Pull the starter grip again, hard and fast, pulling it all the way out to start engine.
4. If the engine does not start, repeat steps 2 and 3.

## CAUTION

**ALWAYS** run engine at *full speed* while pumping.

### Engine Indicators

**Engine Running (Happy Face)** - indicates that the engine and associated components are functioning correctly.

**Battery Charge** - indicates that the battery charging system is not working correctly. If this LED remains on, stop the engine and correct the problem.

**Oil Pressure** - indicates that the oil pressure is low. If this LED remains on, stop the engine and correct the problem.

**Water Temperature** - indicates that the water temperature is too high. If this LED remains on, stop the engine and correct the problem.

**Air Filter** - indicates that the filter is dirty and is not functioning correctly. If this LED remains on, stop the engine and correct the problem.

### Starting the Engine - Electric Start

1. Move the speed lever control to the **START** position (Figure 10).
2. Turn the key in the ignition switch to position **I** and verify that the BATTERY CHARGE indicator comes on (Figure 10).
3. Continue turning the ignition key to position **II**. Verify that the BATTERY CHARGE indicator and the OIL PRESSURE indicator goes off and the ENGINE RUNNING indicator comes on immediately as soon as the engine starts.
3. Release the key as soon as the engine runs. The key should spring back to position **I** and remain there during operation.
4. If the engine does not start, return the key to position **I** before starting the engine again.

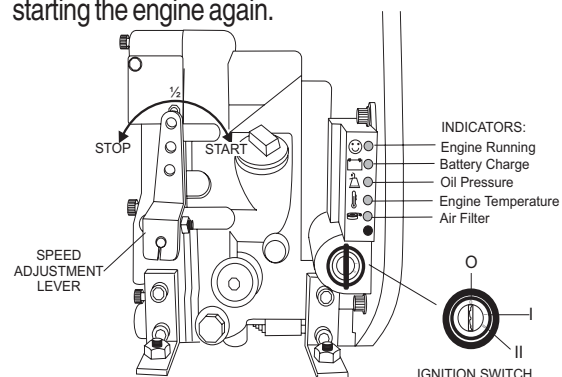
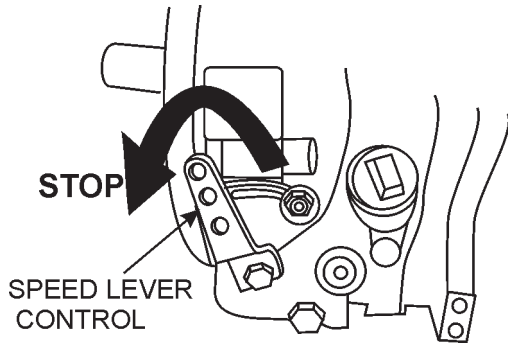

**Figure 10. Engine Electric Start**

## Stopping The Engine

### ***Normal Shutdown***

1. Move the engine speed lever to the low speed and run the engine for about three minutes with no load.
2. After the engine cools, move the engine speed lever to the **STOP** position (Figure 11).



**Figure 11. Engine Speed Lever (STOP Position)**

3. Slowly pull the starter grip (Figure 9) until strong resistance is felt and leave it in this position. This prevents rust from forming while the engine is not in use.

### **CAUTION**

When stopping the engine, reduce the load slowly. Do not stop engine suddenly since it may cause the temperature to rise abnormally.

### ***Emergency Shutdown***

1. To stop engine immediately, quickly place the engine speed lever to the STOP position.

## Pump Vacuum Test

### CAUTION

**DO NOT** attempt to start the engine unless the pump has previously been **primed** with water. Severe pump damage will occur if pump has not been primed.

To perform the pump vacuum test do the following:

1. Remove the pump fill cap (Figure 2), and fill the pump with water.
2. Start the engine as outlined in the initial start-up section, and wait for the pump to begin pumping.
3. As shown in Figure 13, place a water hose inside the discharge opening of the pump, and turn on the water. This flow of water into the discharge opening will **prevent** the pump from running dry.
- \*4. Place the **Pump Vacuum Tester** (P/N 7000030) over the pump suction (inlet) opening (Figure 13) with the vacuum gauge facing upwards. It may be necessary to apply a small amount of water around the rubber seal of the vacuum tester to make a good suction fit.
5. Check and make sure that there are no air leaks between the vacuum tester and the inlet port on the pump. If air leaks are present reset vacuum tester.
6. Run the pump for a few minutes while monitoring the vacuum gauge. If the gauge indicates a reading between -25 and -20 in. Hg. (inches of mercury), then it can be assumed that the pump is working correctly.

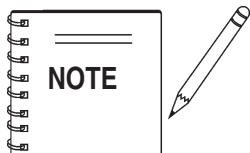

25 in. Hg. (inches of mercury) translates into 25 feet of lift at **sea level**.

7. If the vacuum tester gauge indicates a reading **below** -20 in. Hg, it can then be assumed that the pump is not functioning correctly, and corrective action needs to be taken.
6. To test the **flapper valve**, shut down the engine. The vacuum tester should remain attached to the pump suction inlet port by vacuum. This indicates the pump's flapper valve is seating properly to hold water in the suction hose when the engine is stopped. This prevents backflow and allows for faster priming when the engine is restarted.

## Adjusting Impeller Clearance

1. If it is necessary to replace impeller or volute, be sure clearance between impeller and volute is adjusted correctly.
2. The impeller should be as close to the volute as possible without rubbing against it. Clearance is adjusted by adding or removing **shims** from behind the impeller.
3. Check clearance between impeller and insert by slowly pulling starter rope to turn impeller. Remove spark plug to make it easier to turn impeller.

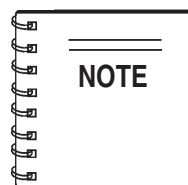

It is important not to remove too many shims or the clearance between the impeller and volute will become **too wide** and pump performance will be reduced. Remember as the impeller wears

down, additional shims may be required to maintain the clearance between the impeller and insert.

4. Check the impeller **every six months** for wear, and for clearance between the impeller face and the volute. Also check the shaft seal for wear, as well as the shaft sleeve.

## Pump Cleaning

After pumping water containing large amounts of dirt and debris, perform the following:

1. Remove the drain plug from the pump housing (Figure 2) and drain any water left in the pump.
2. Loosen the two locking hand knobs (turn counterclockwise) and remove **clean-out cover**.
3. Clean and remove dirt, debris from pump casing. Inspect impeller and volute for wear. Replace any damaged or worn parts.

### CAUTION

The impeller may develop **sharp edges**. Use extreme care when cleaning around the impeller to prevent being cut.

## CAUTION

DO NOT RUN PUMP WITHOUT WATER.

PLACE VACUUM TESTER OVER PUMP SUCTION PORT

DISCHARGE PORT

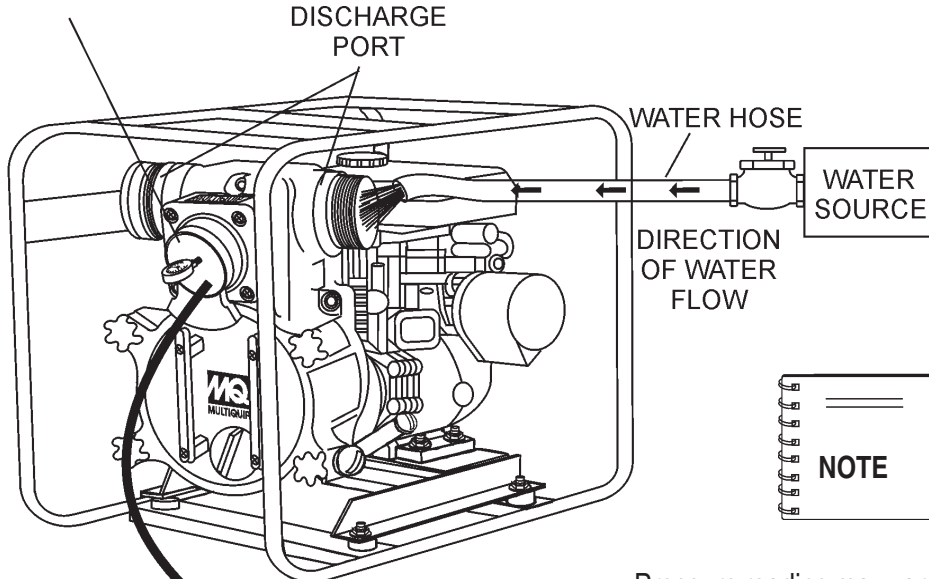

Pressure reading may vary depending on altitude. See Tables 3 and 4 on page 12.

ACCEPTABLE READING SHOULD BE BETWEEN -25 AND -20 IN. HG.

25 IN. HG. TRANSLATES INTO 25 FEET OF LIFT AT SEA LEVEL.

PUMP VACUUM TESTER

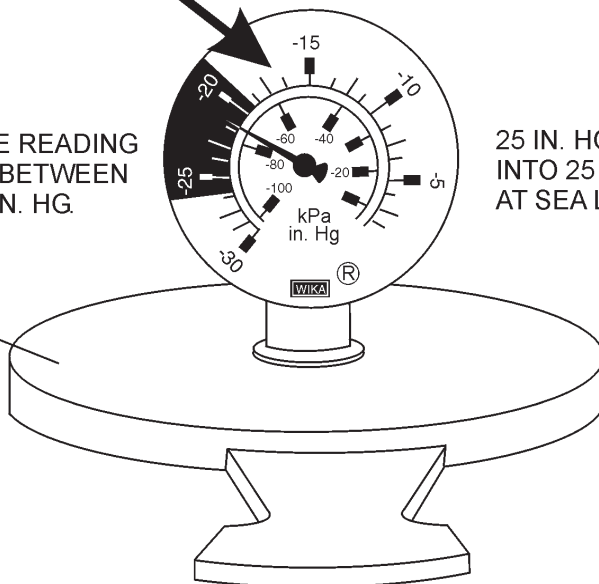

Figure 13. Pump Vacuum Tester

# MAINTENANCE (ENGINE)

## Engine Maintenance

Perform engine maintenance procedures as referenced by Table 6 below:

**Table 6. Engine Maintenance Schedule**

DESCRIPTION (3)	OPERATION	BEFORE	FIRST MONTH OR 10 HRS.	EVERY 3 MONTHS OR 25 HRS.	EVERY 6 MONTHS OR 50 HRS.	EVERY YEAR OR 100 HRS.	EVERY 2 YEARS OR 200 HRS.
Engine Oil	CHECK	X					
	CHANGE		X				
Air Cleaner	CHECK	X					
	CHANGE			X (1)			
All Nuts & Bolts	Re-tighten If Necessary	X					
Cooling Fins	CHECK				X		
Spark Arrester	CLEAN					X	
Fuel Tank	CLEAN					X	
Fuel Filter	CHECK					X	
Idle Speed	CHECK-ADJUST					X (2)	
Valve Clearance	CHECK-ADJUST						X (2)
Fuel lines	CHECK	Every 2 years (replace if necessary) (2)					

(1) Service more frequently when used in **DUSTY** areas.

(2) These items should be serviced by your service dealer, unless you have the proper tools and are mechanically proficient. Refer to the HATZ shop manual for service procedures.

(3) For commercial use, log hours of operation to determine proper maintenance intervals.

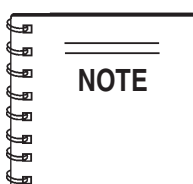

Reference manufacturer engine manual for specific servicing instructions.



## Maintenance

Perform the engine maintenance procedures as indicated below:

### DAILY

- Thoroughly remove dirt and oil from the engine and control area. Clean or replace the air cleaner elements as necessary. Check and retighten all fasteners as necessary. Check the spring box and bellows for oil leaks. Repair or replace as needed.

### WEEKLY

- Remove the fuel filter cap and clean the inside of the fuel tank.
- Remove or clean the filter at the bottom of the tank.

### ENGINE OIL

1. Drain the engine oil when the oil is **warm** as shown in Figure 14.
2. Remove the oil drain bolt and sealing washer and allow the oil to drain into a suitable container.
3. Replace engine oil with recommended type oil as listed in Table 5. Engine oil capacity is 1.6 quarts (1.5 liters). **DO NOT** overfill.
4. Install drain bolt with sealing washer and tighten securely.

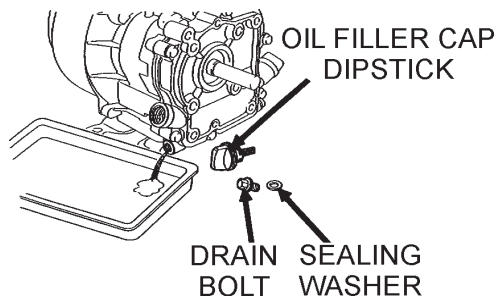

Figure 14. Engine Oil (Draining)

## DANGER

**DO NOT** use gasoline as a cleaning solvent, because that would create a risk of fire or explosion.

### ENGINE AIR CLEANER

1. Loosen the wing nut and detach the cover of the air cleaner shown in Figure 15.
2. Tap the element (Figure 15) several times on a hard surface to remove dirt, or blow compressed air, not exceeding 30 psi (207 kPa, 2.1 kgf/cm<sup>2</sup>), through the element side. **NEVER** wash the element with detergent because the element is oil-soaked type. Replace the element when the output decreases or bad exhaust color is noticed.

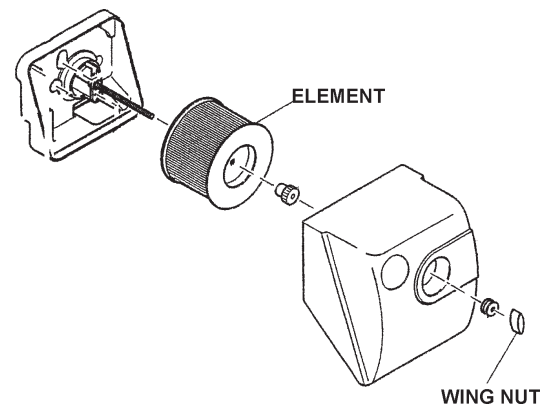

Figure 15. Engine Air Cleaner

## PREPARATION FOR LONG -TERM STORAGE

### Pump Storage

For storage of the pump for over 30 days, the following is required:

- Drain the fuel tank completely.
- Run the engine for about 3 minutes and then stop.
- Stop the engine. Drain the engine crankcase oil while the engine is still warm. Fill engine crankcase with fresh oil.
- Pull the recoil starter grip (Figure 17) 2 or 3 times. **DO NOT** start the engine.

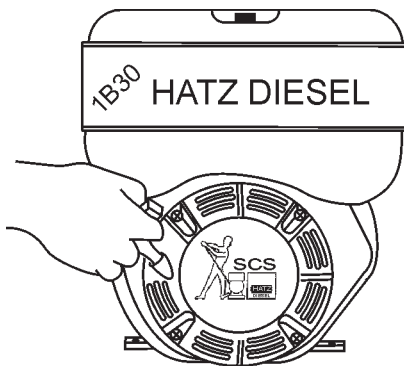

Figure 17. Recoil Starter Grip

- Pull the recoil starter grip slowly. **STOP** when it feels tight. This closes the intake and exhaust valves (compression position), and helps prevent rust from forming.
- Wipe any oil or dirt that may have accumulated on the engine.
- Remove the drain plug from the pump and drain out any water left in the housing.
- Remove the pump cover and clean the inside of pump housing. Coat the inside of pump housing with a light film of oil to reduce corrosion. A spray can of oil works well for this application.
- Cover suction and discharge ports with duct tape to prevent any foreign matter from falling into pump.
- Cover pump and engine with plastic covering or equivalent and store in a clean, dry place.
- To protect the water-cooled seals, place one-half pint of lubricating oil (new or used) through the discharge opening on the pump and crank the engine several times. This will prevent excessive corrosion and also keep the mechanical seal lubricated.

# TROUBLESHOOTING (ENGINE)

**TABLE 7. ENGINE TROUBLESHOOTING**

SYMPTOM	POSSIBLE PROBLEM	SOLUTION
Engine will not start or start is delayed, although engine can be turned over.	Speed control lever is in "STOP" position?	Set speed control lever to "START" position.
	No fuel reaching injection pump?	Add fuel. Check entire fuel system.
	Defective fuel pump?	Replace fuel pump.
	Fuel filter clogged?	Replace fuel filter and clean tank.
	Faulty fuel supply line?	Replace or repair fuel line.
	Compression too low?	Check piston, cylinder and valves. Adjust or repair per engine repair manual.
	Fuel injector not working correctly?	Repair or replace injector in accordance with engine repair manual.
	Oil pressure too low?	Check engine oil pressure.
	Low starting temperature limit exceeded	Comply with cold starting instructions and proper oil viscosity.
At low temperatures engine will not start.	Fuel separates has inadequate resistance to low temperatures?	Check whether clear (not turbid) fuel emerges from the fuel line (detach from injection pump). If the fuel is turbid or separated, warm up the engine or drain the complete fuel supply system. Refuel with winter grade diesel fuel.
	Engine oil too thick?	Refill engine crankcase with correct type of oil for winter environment.
Engine fires but stops soon as starter is switched off.	Fuel filter blocked?	Replace fuel filter.
	Fuel supply blocked?	Check the entire fuel system.
Engine stops by itself during normal operation.	Fuel tank empty?	Add fuel.
	Fuel filter blocked?	Replace fuel filter.
Low engine power, output and speed.	Fuel tank empty?	Fill with No.2 diesel fuel.
	Fuel filter clogged?	Replace fuel filter.
	Fuel tank venting is inadequate?	Ensure that tank is adequately vented.
	Speed control lever does not remain in selected position?	See engine manual for corrective action.
	Engine oil level too full?	Correct engine oil level?
Low engine power output and low speed, black exhaust smoke.	Air filter blocked?	Clean or replace air filter.
	Incorrect valve clearances?	Adjust valves per engine specification.
	Malfunction at injector?	See engine manual.

# TROUBLESHOOTING (PUMP)

**TABLE 8. PUMP TROUBLESHOOTING**

SYMPTOM	POSSIBLE PROBLEM	SOLUTION
Pump does not take on water.	Not enough priming water in the housing?	Add water.
	Engine speed too low?	Increase throttle.
	Strainer plugged?	Clean strainer.
	Suction hose damaged?	Replace or repair hose, and clamps
	Air leak at suction port?	Check that fittings are tight and properly sealed.
	Pump is located too high above water line?	Move pump closer to water.
	Debris collecting in pump housing?	Clean pump housing.
	Too much distance between impeller and volute.	Adjust clearance by adding shims or replace impeller. Min. .006" - Max. .020"
	Water leaking out weep hole between pump and engine?	Check condition of mechanical seal and gaskets, between pump end and engine housing.
Pump takes in water, little or no discharge.	Engine speed too low?	Increase throttle speed.
	Suction strainer partially plugged?	Clean strainer.
	Impeller/Volute worn?	Adjust clearance by adding shims or replace impeller/volute
Suction hose leaks at inlet.	Fittings/clamps are not sealed properly?	Tighten, replace or add clamp. (Keep extra seals on pump)
	Hose diameter is too large?	Use smaller diameter hose or replace hose.
Discharge does not stay on coupling.	Pressure too high?	Check pressure, add additional clamp.
	Hose kinked or end blocked?	Check hose.
Impeller does not turn: pump is hard to start.	Impeller jammed or blocked?	Open pump cover and clean dirt and debris from inside housing.
	Impeller and volute binding?	Adjust clearance by removing shim from behind impeller.
	Defective engine?	See Engine Owner's Manual.



# EXPLANATION OF CODE IN REMARKS COLUMN

The following section explains the different symbols and remarks used in the Parts section of this manual. Use the help numbers found on the back page of the manual if there are any questions.

The contents and part numbers listed in the parts section are subject to change **without notice**. Multiquip does not guarantee the availability of the parts listed.

Sample Parts List:

NO.	PART NO.	PART NAME	QTY.	REMARKS
1	12345	BOLT .....	1	INCLUDES ITEMS W/*
2*		WASHER, 1/4 IN. ....		NOT SOLD SEPARATELY
2*	12347	WASHER, 3/8 IN. ...	1	MQ-45T ONLY
3	12348	HOSE .....	A/R	MAKE LOCALLY
4	12349	BEARING .....	1	S/N 2345B AND ABOVE

## NO. Column

**Unique Symbols** - All items with same unique symbol (\*, #, +, %, or >) in the number column belong to the same assembly or kit, which is indicated by a note in the "Remarks" column.

**Duplicate Item Numbers** - Duplicate numbers indicate multiple part numbers are in effect for the same general item, such as different size saw blade guards in use or a part that has been updated on newer versions of the same machine.



When ordering a part that has more than one item number listed, check the remarks column for help in determining the proper part to order.

## PART NO. Column

**Numbers Used** - Part numbers can be indicated by a number, a blank entry, or TBD.

TBD (To Be Determined) is generally used to show a part that has not been assigned a formal part number at time of publication.

A blank entry generally indicates that the item is not sold separately or is not sold by Multiquip. Other entries will be clarified in the "Remarks" Column.

## QTY. Column

**Numbers Used** - Item quantity can be indicated by a number, a blank entry, or A/R.

A/R (As Required) is generally used for hoses or other parts that are sold in bulk and cut to length.

A blank entry generally indicates that the item is not sold separately. Other entries will be clarified in the "Remarks" Column.

## REMARKS Column

Some of the most common notes found in the "Remarks" Column are listed below. Other additional notes needed to describe the item can also be shown.

**Assembly/Kit** - All items on the parts list with the same unique symbol will be included when this item is purchased.

Indicated by:

"INCLUDES ITEMS W/(unique symbol)"

**Serial Number Break** - Used to list an effective serial number range where a particular part is used.

Indicated by:

"S/N XXXXX AND BELOW"

"S/N XXXX AND ABOVE"

"S/N XXXX TO S/N XXX"

**Specific Model Number Use** - Indicates that the part is used only with the specific model number or model number variant listed. It can also be used to show a part is NOT used on a specific model or model number variant.

Indicated by:

"XXXXX ONLY"

"NOT USED ON XXXX"

**"Make/Obtain Locally"** - Indicates that the part can be purchased at any hardware shop or made out of available items. Examples include battery cables, shims, and certain washers and nuts.

**"Not Sold Separately"** - Indicates that an item cannot be purchased as a separate item and is either part of an assembly/kit that can be purchased, or is not available for sale through Multiquip.

## QP4TZ TRASH PUMP 1 TO 3 UNITS W/ 1B40U-2203A

Qty.	P/N	Description
2	KIT4TH	KIT, MECHANICAL SEAL, O-RINGS
1	1471040030	IMPELLER
4	0631211159	FLOODING CAP
3	50484100	ELEMENT, AIR CLEANER
1	05088901	ROPE STARTER
1	01535302	CAP, FUEL TANK
3	01635210	FUEL FILTER ASSY
3	50404900	KEY, STARTER SWITCH
3	01542702	OIL SUCTION FILTER ASSY

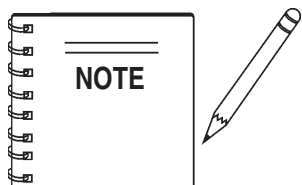

Part number on this Suggested Spare Parts List may supersede/replace the P/N shown in the text pages of this manual.

# PUMP ASSY.

## PUMP ASSY.

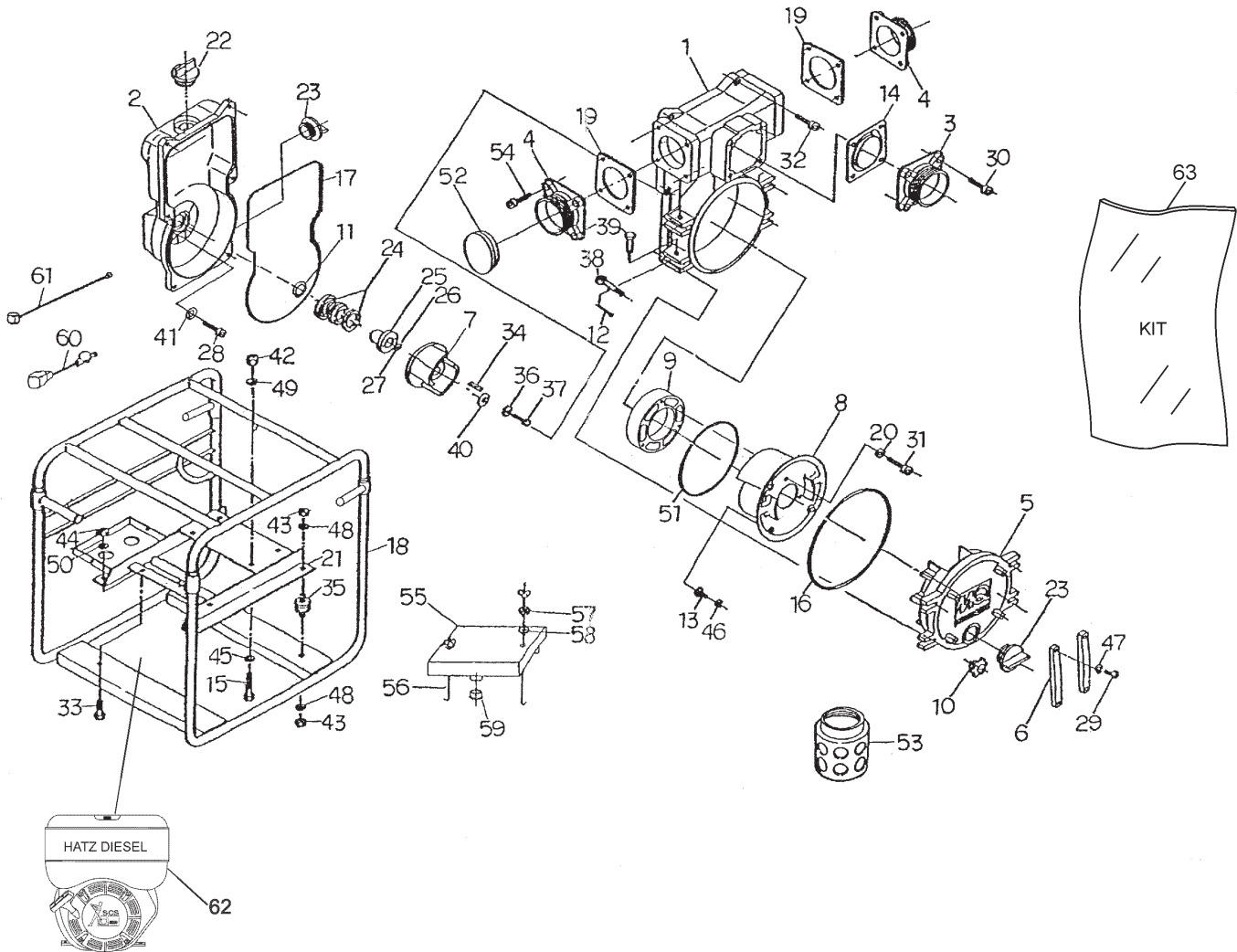



PUMP ASSY.

<u>NO.</u>	<u>PART NO.</u>	<u>PART NAME</u>	<u>QTY.</u>	<u>REMARKS</u>
1	14660600100002	CASING	1	
2	14460600200002	CASING COVER .....	1	OCTOBER 2007 AND BELOW
2	14460600210002	CASING COVER .....	1	NOVEMBER 2007 AND ABOVE
3	14660000900002	SUCTION COVER	1	
4	14660000900002	DELIVERY COVER	2	
5	14660601700002	DRAIN COVER	1	
6	12470002500002	DRAIN COVER KNOB	2	
7	1471040030	IMPELLER	1	
8	1466000130	VOLUTE CASING	1	
9	1466040700	SUCTION PLATE	1	
10	14660002200002	DRAIN COVER SET HANDLE	4	
11#	0482200240	O'RING (MECHANICAL SEAL SLEEVE)	1	
12	0641400430	SPLIT PIN	4	
13	0131190820	CAP SCREW (VOLUTE CASING)	3	
14	1401350350	CHECK VALVE	1	
15	0105051030	BOLT (ENGINE), M10 X 30	4	
16#	0483602750	O'RING (DRAIN COVER)	1	
17	1466330460	O'RING (CASING)	1	
18	1471214010P002	BASE, SS400	1	
19	1401330360	DELIVERY COVER PACKING	2	
20	0451290080	SPRING WASHER M8	3	
21	14712140200014	ENGINE BASE, SS400	1	
22	0631211159	FLOODING CAP, PF 1 1/2"	1	
23	0631211159	DRAIN CAP, PF1 1/2"	2	
24#	0803442930	MECHANICAL SEAL	1	
25#	0811885433	MECHANICAL SEAL SLEEVE	1	
26#	0852834525	ADJUST LINER, 45 x 25.4 MM T0.3	1	
27#	0852854525	ADJUST LINER, 45 x25.4 MM T0.5	1	
28	0131091065	CAP SCREW (CASING), M10 X 65	4	
29	0141050825	SCREW (DRAIN COVER SET HANDLE), M8 X 25	4	
30	0131151225	CAP SCREW (SUCTION COVER), M12 X 25	4	
31	0131190820	CAP SCREW (WEAR PLATE), M8 X 20	3	
32	0131151230	CAP SCREW (CASING), M12 X 30	6	
33	0105051040	BOLT (PUMP), M10 X 40	2	

# PUMP ASSY.

## PUMP ASSY.

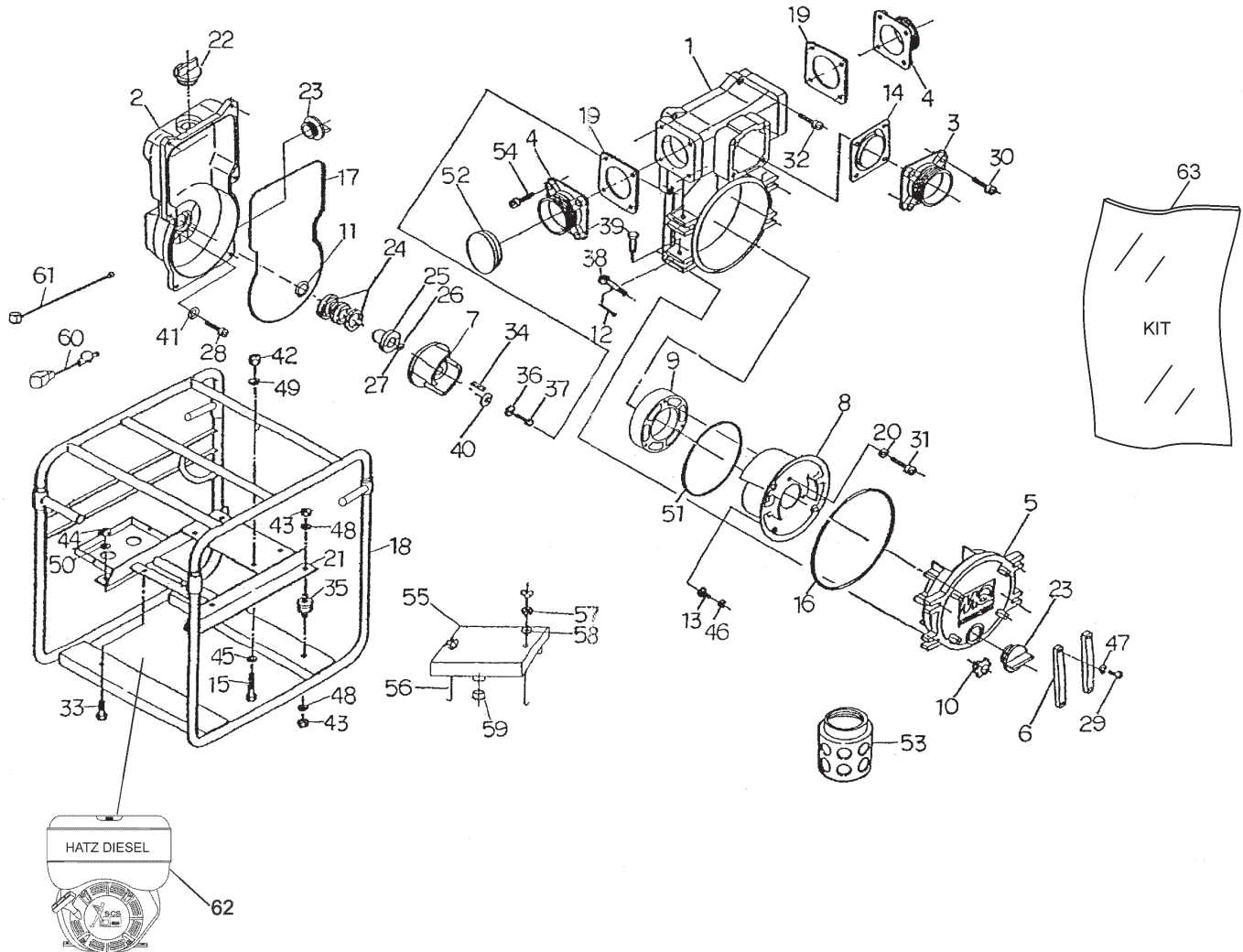

# PUMP ASSY. (CONTINUED)

PUMP ASSY. (CONTINUED)

<u>NO.</u>	<u>PART NO.</u>	<u>PART NAME</u>	<u>QTY.</u>	<u>REMARKS</u>
34	0520040451	KEY	1	
35	0723302546	CUSHION RUBBER	4	
36	0451290070	SPRING WASHER, IMPELLER	1	
37	0107090645	BOLT, IMPELLER	1	
38	1466200270	HINGE BOLT M10 X 65	4	
39	1446220280	HINGE PIN	4	
40	1466251240	IMPELLER WASHER	1	
41	0458220100	SEAL WASHER (CASING COVER), M10	4	
42	0205450100	NUT (ENGINE), M10	4	
43	0205450100	NUT (CUSHION RUBBER), M10	8	
44	0205450100	NUT (PUMP), M10	2	
45	0401450100	WASHER (ENGINE), M10	4	
46	0451290080	SPRING WASHER (VOLUTE CASING), M8	3	
47	0451250080	SPRING WASHER (DRAIN COVER HANDLE), M8	4	
48	0451250100	SPRING WASHER (CUSHION RUBBER), M10	8	
49	0451250100	SPRING WASHER (ENGINE), M10	4	
50	0451250100	SPRING WASHER (PUMP), M10	2	
51#	0481572500	O-RING (VOLUTE CASING)	1	
52	1466068050	CAP	1	
53	0742214100	STRAINER	1	
54	0131151220	CAP SCREW (DELIVERY COVER)	8	
55	09592250000014	BATTERY COVER	1	
56	0950241265AP002	BATTERY BOLT WITH NUT	2	
57	0451250080	SPRING WASHER	2	
58	0401450080	WASHER (BATTERY)	2	
59	1412317030	CAP	3	
60	0975209300	SHORT CORD WITH TERMINALS	1	
61	0976209450	LONG CORD WITH TERMINALS	1	
62	1B40U-2203A	ENGINE, HATZ	1	
63	KIT4TH	KIT, MECHANICAL SEAL, SLEEVE, O-RINGS .....	1	INCLUDES ITEMS W/ #

# HATZ 1B40U-2203A — SPARE PARTS KITS ASSY.

SPARE PARTS KITS ASSY.

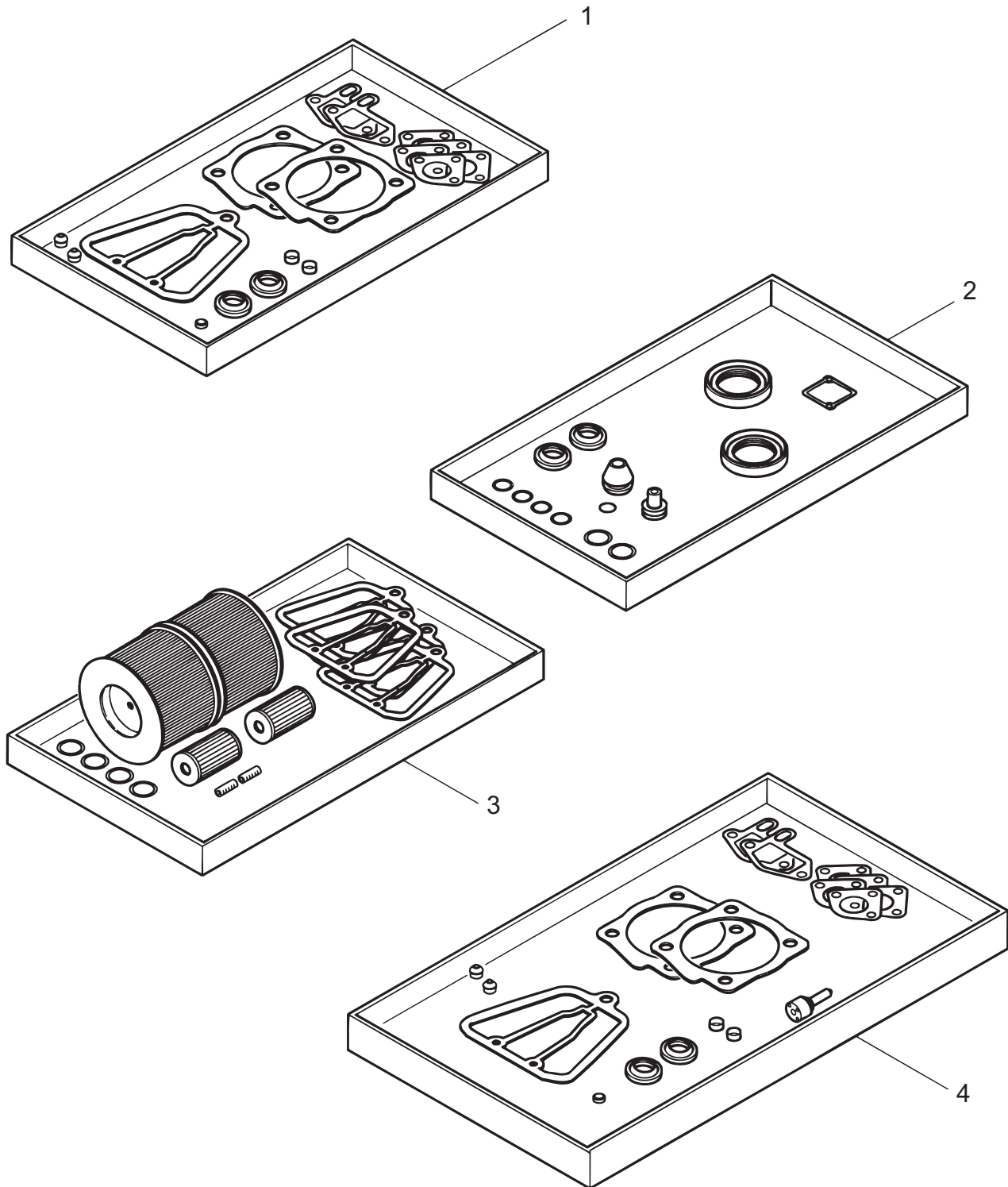

# HATZ 1B40U-2203A — SPARE PARTS KITS ASSY.

SPARE PARTS KITS ASSY.

<u>NO.</u>	<u>PART NO.</u>	<u>PART NAME</u>	<u>QTY.</u>	<u>REMARKS</u>
1	01679202	GASKET SET CYL.HEAD	1	
2	01679302	GASKET SET CRK.CASE	1	
3	01679400	1000H MAINTK.KIT	1	
4	01679510	EMERGENCY KIT	1	

# HATZ 1B40U-2203A — CRANKCASE ASSY.

## CRANKCASE ASSY.

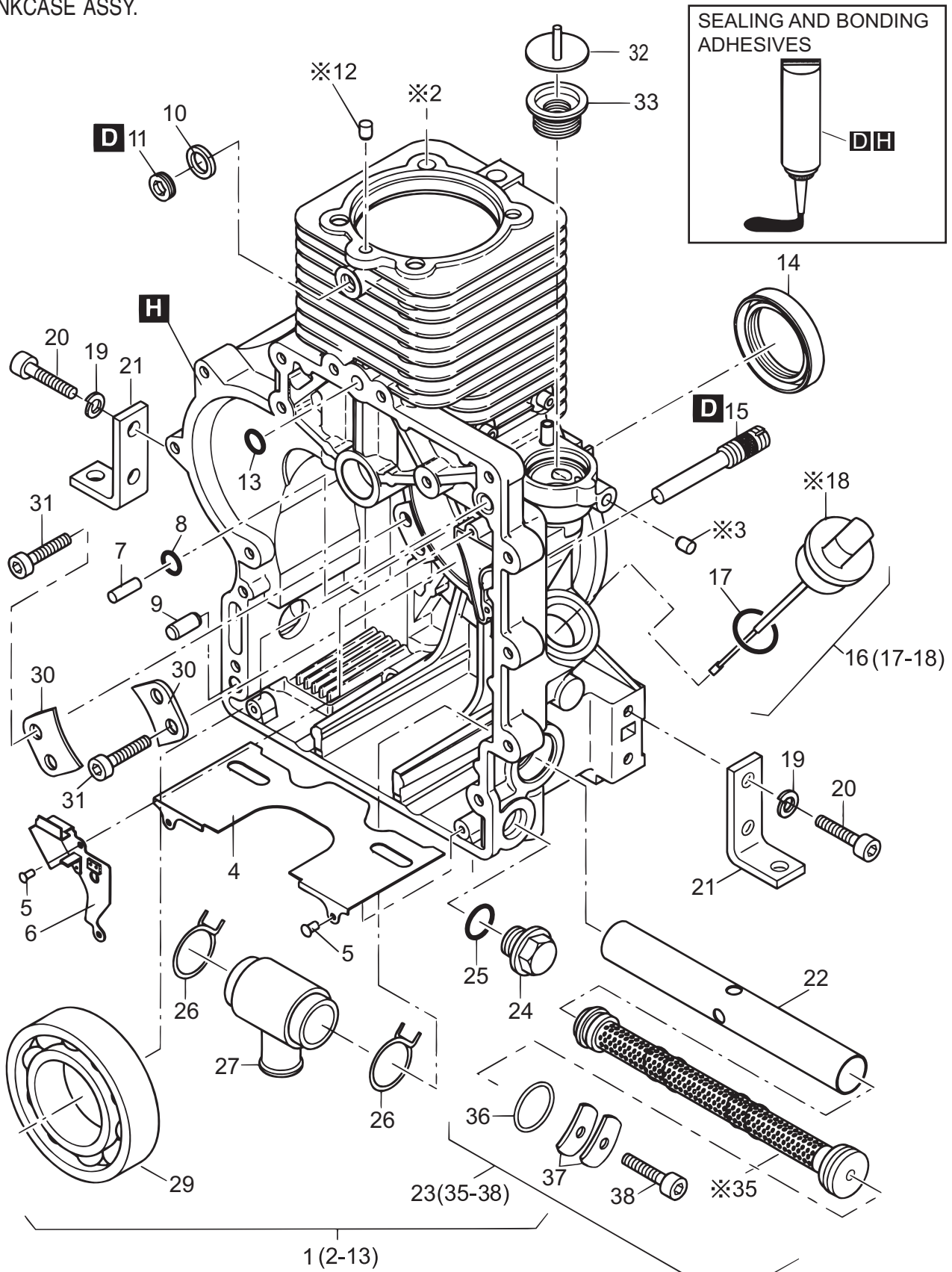

※ Parts not available separately

# HATZ 1B40U-2203A — CRANKCASE ASSY.

## CRANKCASE ASSY.

<u>NO.</u>	<u>PART NO.</u>	<u>PART NAME</u>	<u>QTY.</u>	<u>REMARKS</u>
D	50223300	LOCTITE221 50ML	1	
H	50282501	SILICON 30ML	1	
1	01679100	CRANKCASE ASSY .....	1	INCLUDES ITEMS W/ #
2#		CRANKCASE .....	1	NOT SOLD SEPARATELY
3#		PLUG .....	1	NOT SOLD SEPARATELY
4#	04141600	COVER SHEET	1	
5#	40002600	BLIND RIVET3.2	1	
6#	01336400	COVER SHEET (SIDE)	4	
7#	50502801	CYL.PIN M6X24	1	
8#	50440300	O-RING 8X1.5	1	
9#	50249102	CYL.PIN M6X24	1	
10#	50062400	JOINT A10X13.5	1	
11#	50062300	CLOS.SCREW M10X1	1	
12#		PLUG .....	1	NOT SOLD SEPARATELY
13#	40022300	O-RING 8X2	1	
14	50479000	OIL SEAL 45X60X8	1	
15	04144401	GRUB SCREW	1	
16	01342800	DIPSTICK ASSY .....	1	INCLUDES ITEMS W/ \$
17\$	04125000	SEALING RING	1	
18\$		DIPSTICK .....	1	NOT SOLD SEPARATELY
19	50208500	SPRING WASHER 8	8	
20	04219500	ALLEN SCREW M8X40	8	
21	04144701	ENGINE BRACKET	4	
22	04141500	TUBE F.OIL FILTER	1	
23	01542702	OIL SUCTION FILTER ASSY .....	1	INCLUDES ITEMS W/ %
24	50373100	DRAIN PLG.MAGNT.M22	1	
25	50001600	JOINT A22X27	1	
26	05036900	HOSE CLIP	2	
27	04163000	T-PIECE	1	
29	50478900	GROOV.BALLBEAR.6310	1	
30	04133800	PLATE	3	
31	50564200	ALLEN SCREW M6X18	6	
32	01555800	COVER	1	
33	03568701	OIL SUPPLEMENT PLUG	1	
35%		FILTER, OIL SUCTION .....	1	NOT SOLD SEPARATELY
36%	50475901	O-RING 20X4	1	
37%	05148200	PLATE SPRING	2	
38%	50170700	ALLEN SCREW M6X16	1	

# HATZ 1B40U-2203A — COMPENSATION OF MASSES ASSY.

COMPENSATION OF MASSES ASSY.

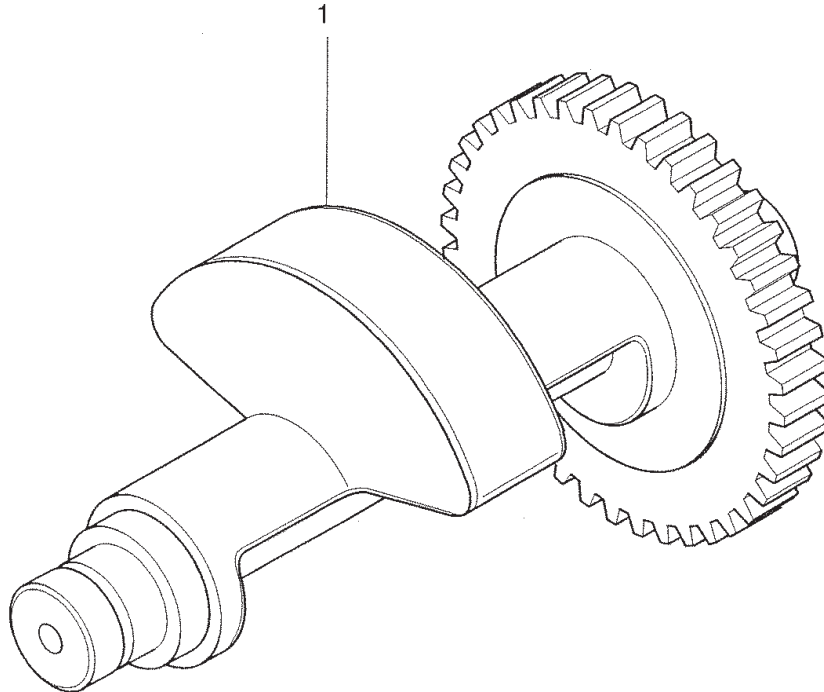



# HATZ 1B40U-2203A — COMPENSATION OF MASSES ASSY.

COMPENSATION OF MASSES ASSY.

<u>NO.</u>	<u>PART NO.</u>	<u>PART NAME</u>	<u>QTY.</u>	<u>REMARKS</u>
1	01349201	COMPENSATING SHAFT	1	

# HATZ 1B40U-2203A — CRANKSHAFT ASSY.

CRANKSHAFT ASSY.

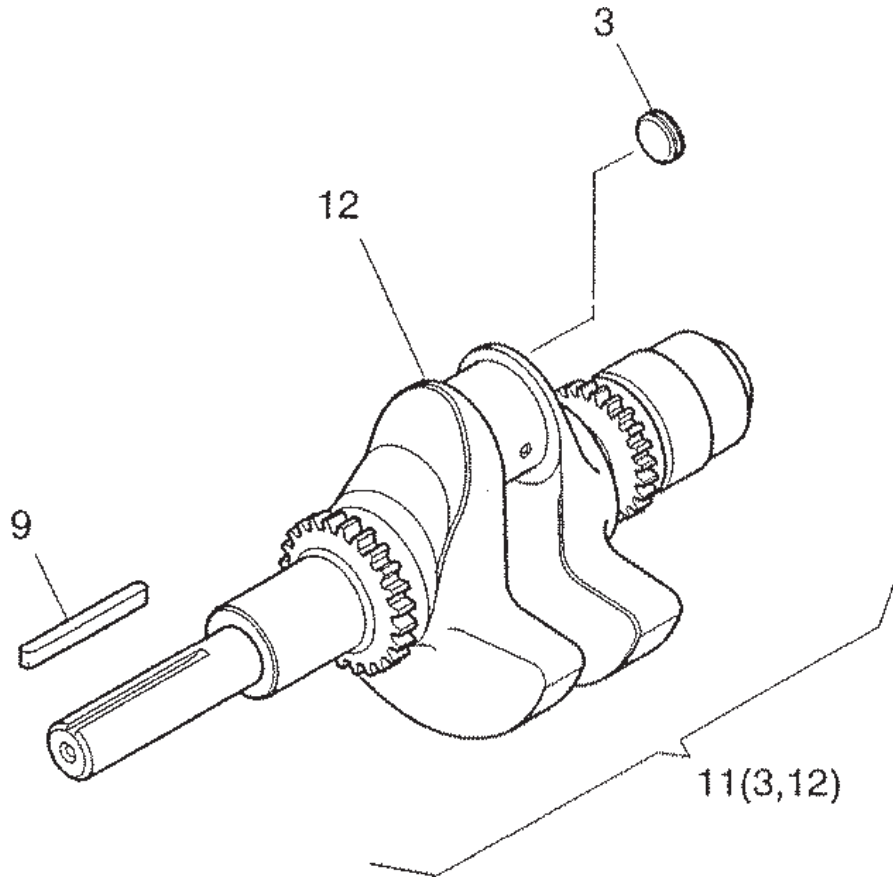

# HATZ 1B40U-2203A — CRANKSHAFT ASSY.

CRANKSHAFT ASSY.

<u>NO.</u>	<u>PART NO.</u>	<u>PART NAME</u>	<u>QTY.</u>	<u>REMARKS</u>
3#	50529700	COVER 14	1	
9	05141600	KEY 6,35X61	1	
11	01359201	CRANKSHAFT ASSY .....	1 .....	INCLUDES ITEMS W/ #
12#		CRANKSHAFT .....	1 .....	NOT SOLD SEPARATELY

# HATZ 1B40U-2203A — CAMSHAFT ASSY.

CAMSHAFT ASSY.

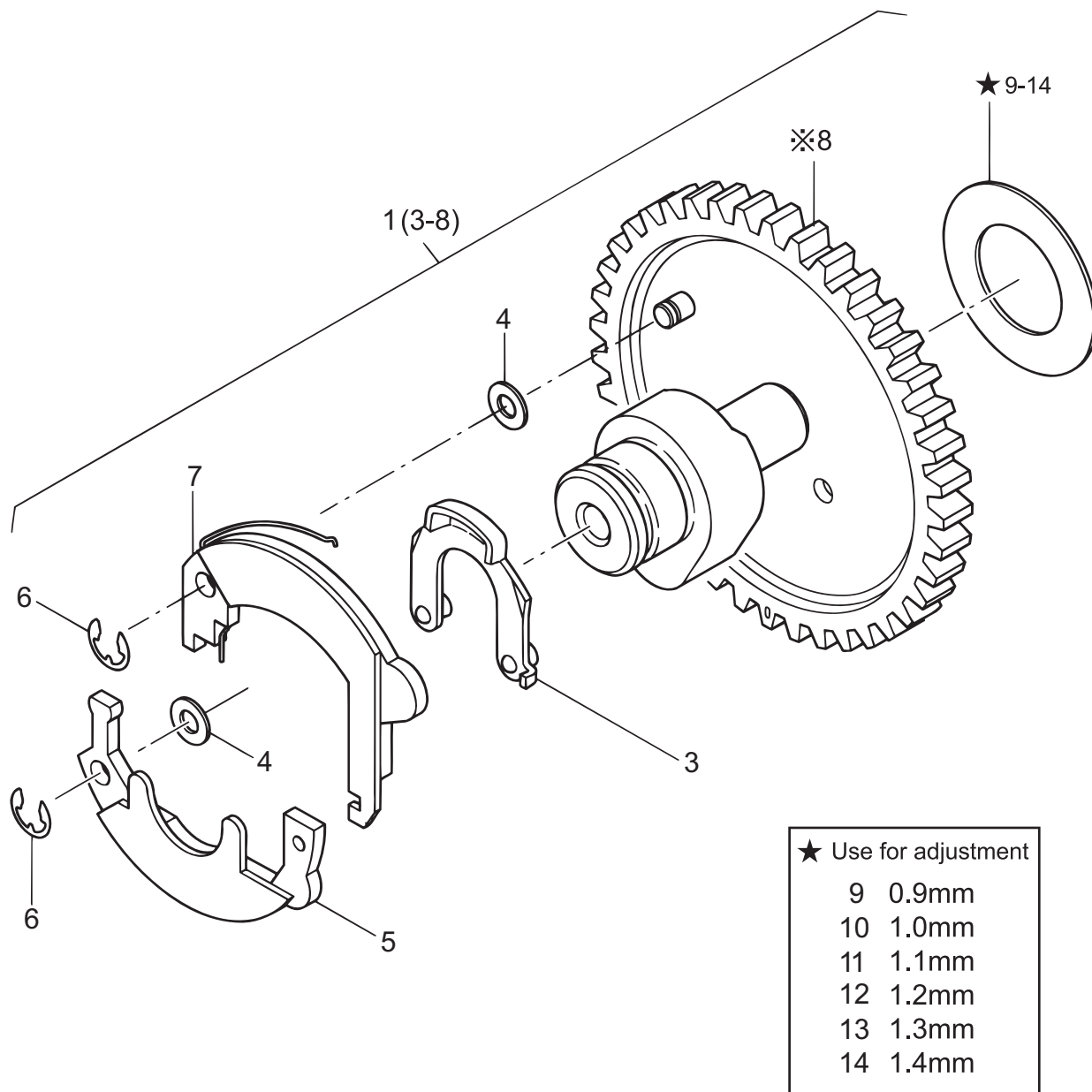

※ Parts not available separately

# HATZ 1B40U-2203A — CAMSHAFT ASSY.

## CAMSHAFT ASSY.

<u>NO.</u>	<u>PART NO.</u>	<u>PART NAME</u>	<u>QTY.</u>	<u>REMARKS</u>
1	01345003	CAMSHAFT ASSY. ....	1	INCLUDES ITEMS W/ #
3#	01326401	CAMLEVER	1	
4#	50123200	SHIM 5X10X0.5	2	
5#	01326600	FLYWEIGHT	1	
6#	50255300	LOCKING WASHER 3.2	2	
7#	01326501	F.WEIGHT HAND-ST.	1	
8#		CAMSHAFT .....	1	NOT SOLD SEPARATELY
9	04121700	SHIM 23X38X0.9	1	
10	04112100	SHIM 23X38X1.0	1	
11	04112200	SHIM 23X38X1.1	1	
12	04112300	SHIM 23X38X1.2	1	
13	04125100	SHIM 23X38X1.3	1	
14	04125200	SHIM 23X38X1.4	1	

# HATZ 1B40U-2203A — PISTON, CONROD, CYLINDER ASSY.

PISTON, CONROD, CYLINDER ASSY.

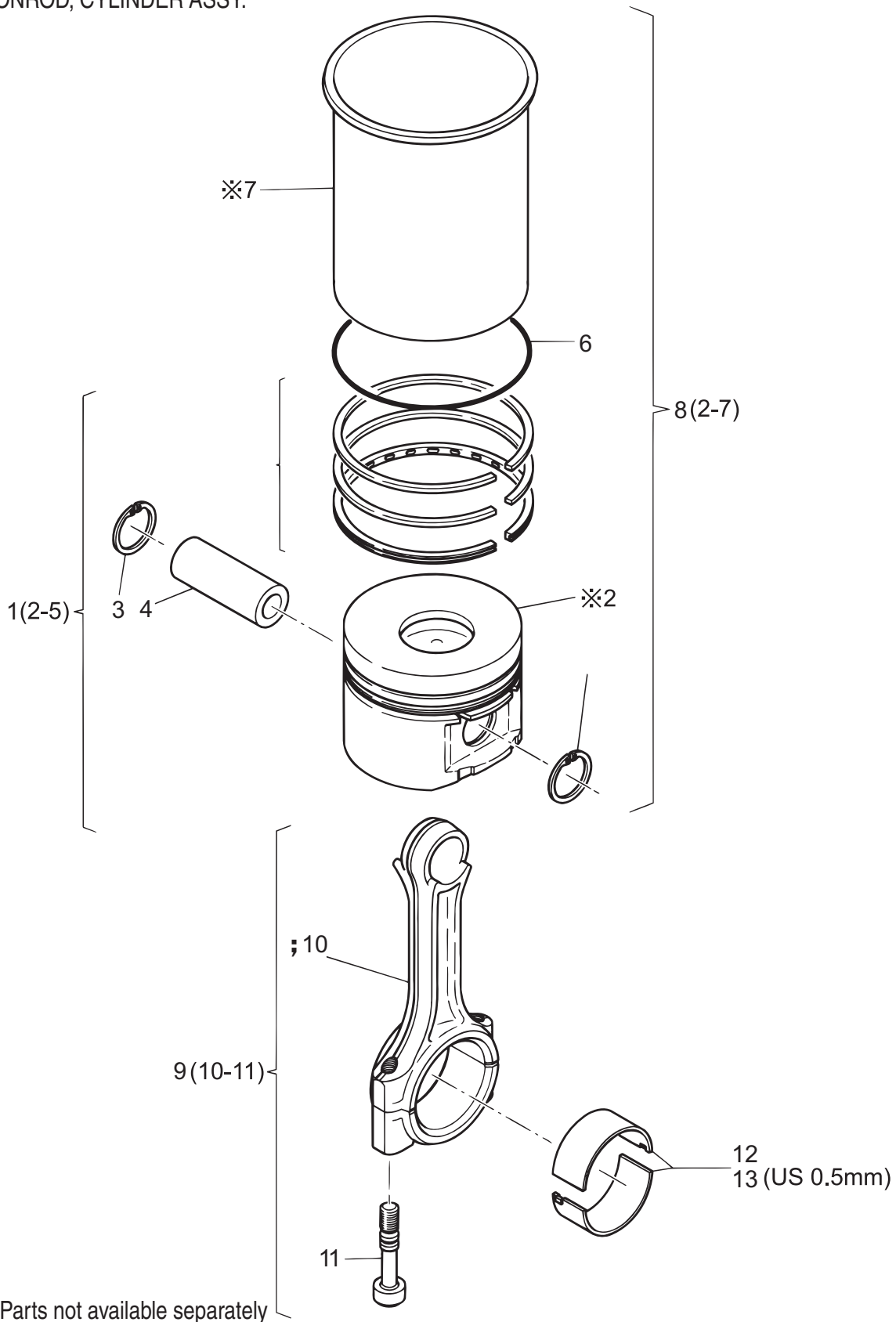

# HATZ 1B40U-2203A — PISTON, CONROD, CYLINDER ASSY.

PISTON, CONROD, CYLINDER ASSY.

<u>NO.</u>	<u>PART NO.</u>	<u>PART NAME</u>	<u>QTY.</u>	<u>REMARKS</u>
1	01374810	PISTON ASSY 88 EPA2 .....	1 .....	INCLUDES ITEMS W/ %
2#%		PISTON .....	1 .....	NOT SOLD SEPARATELY
3#%	50482300	CIRCLIP 22X1	2	
4#%	50527100	GUDGEON PIN	1	
5#%	01374701	PISTON RING SET 88	1	
6#	50479301	O-RING 93 X 1.5	1	
7#		CYLINDER .....	1 .....	NOT SOLD SEPARATELY
8	01679610	CYLINDER W/ PISTON ASSY .....	1 .....	INCLUDES ITEMS W/ #
9	01343500	CONROD ASSY .....	1 .....	INCLUDES ITEMS W/ \$
10\$		CONROD .....	1 .....	NOT SOLD SEPARATELY
11\$	04100500	CONROD SCREW	2	
12	01679800	BIG END BEARING	1	
13	01692700	BIG END BEAR.US0.5	1	

# HATZ 1B40U-2203A — CYLINDER HEAD ASSY.

## CYLINDER HEAD ASSY.

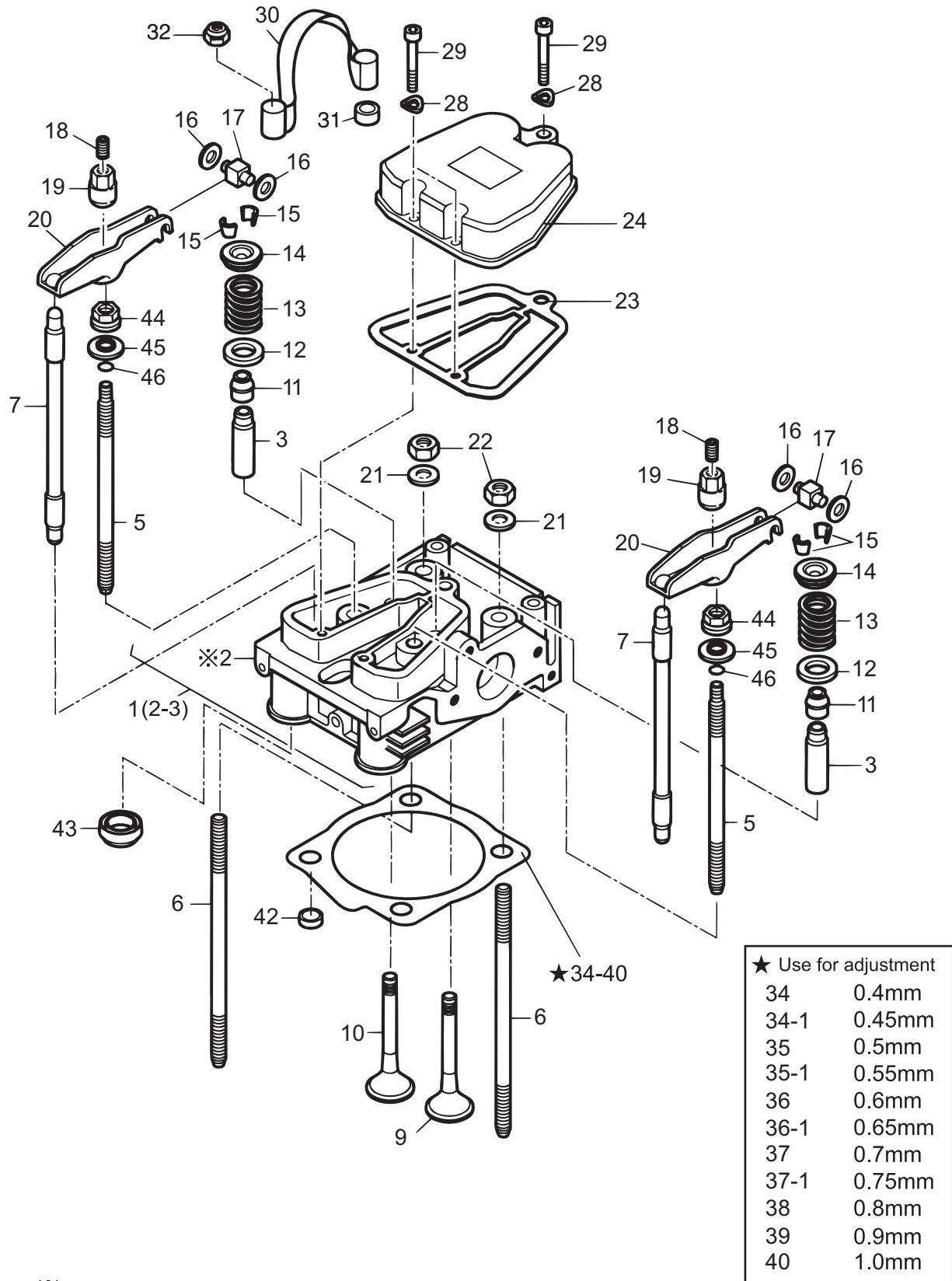

※ Parts not available separately



# HATZ 1B40U-2203A — CYLINDER HEAD ASSY.

## CYLINDER HEAD ASSY.

<u>NO.</u>	<u>PART NO.</u>	<u>PART NAME</u>	<u>QTY.</u>	<u>REMARKS</u>
1	01850900	CYLINDER HEAD ASSY EPA2 .....	1 .....	INCLUDES ITEMS W/ #
2#		CYLINDER HEAD .....	1 .....	NOT SOLD SEPARATELY
3#	05209700	VALVE GUIDE	2	
5	05159600	STUD CYL. HEAD	2	
6	05159700	STUD CYL. HEAD	2	
7	01374000	PUSHROD	2	
9	05145100	VALVE INLET	1	
10	05145200	VALVE EXHAUST	1	
11	50425800	STEM SEAL CAP	2	
12	04147100	WASHER	2	
13	04146900	VALVE SPRING	2	
14	04147000	SPRING PLATE	2	
15	50425700	COLLET	2	
16	05240700	SUPP.DISCD 6X12X1.35	4	
17	05091101	SLIDER	2	
18	50513100	GRUB SCREW M8X10	2	
19	05054700	NUT F. ROCKERARM	2	
20	05146701	ROCKER	2	
21	05099300	WASHER 10.1X24X3	2	
22	50396600	HEXAGON NUT M 10	2	
23	05156401	GASKET CYL. HEAD	1	
24	05146501	COVER F. CYL. HEAD	1	
28	50081200	SPRING WASHER A 6	3	
29	50374900	ALLEN SCREW M 6X35	3	
30	04117701	LIFTING STRAP	1	
31	04126100	PROTECTION HOSE	2	
32	40028600	HEX.NUT M10	2	
34	05158903	GASKET F.CYL.HEAD 0.4	1	
34-1	04248400	GASKET F.CYL.H. 0.45	1	
35	04248500	GASKET F.CYL.H. 0.55	1	
35-1	05159003	GASKET F.CYL.H. 0.5	1	
36	05159103	GASKET F.CYL.HEAD 0.6	1	
36-1	04248600	GASKET F.CYL.H. 0.65	1	
37	05159203	GASKET F.CYL.HEAD 0.7	1	
37-1	04248700	GASKET F.CYL.H. 0.75	1	
38	05159303	GASKET F.CYL.HEAD 0.8	1	
39	05159403	GASKET F.CYL.HEAD 0.9	1	
40	05159503	GASKET F.CYL.HEAD 1.0	1	
42	04174500	CENTR.BUSH	2	
43	04106500	SEALING RING TIM.COV.	2	
44	03171800	COLLAR NUT	2	
45	04243700	DISC 8.1X12X2.0	2	
46	50563900	O-RING 10X2.5	2	

# HATZ 1B40U-2203A — OIL PUMP AND GOVERNOR ASSY.

## OIL PUMP AND GOVERNOR ASSY.

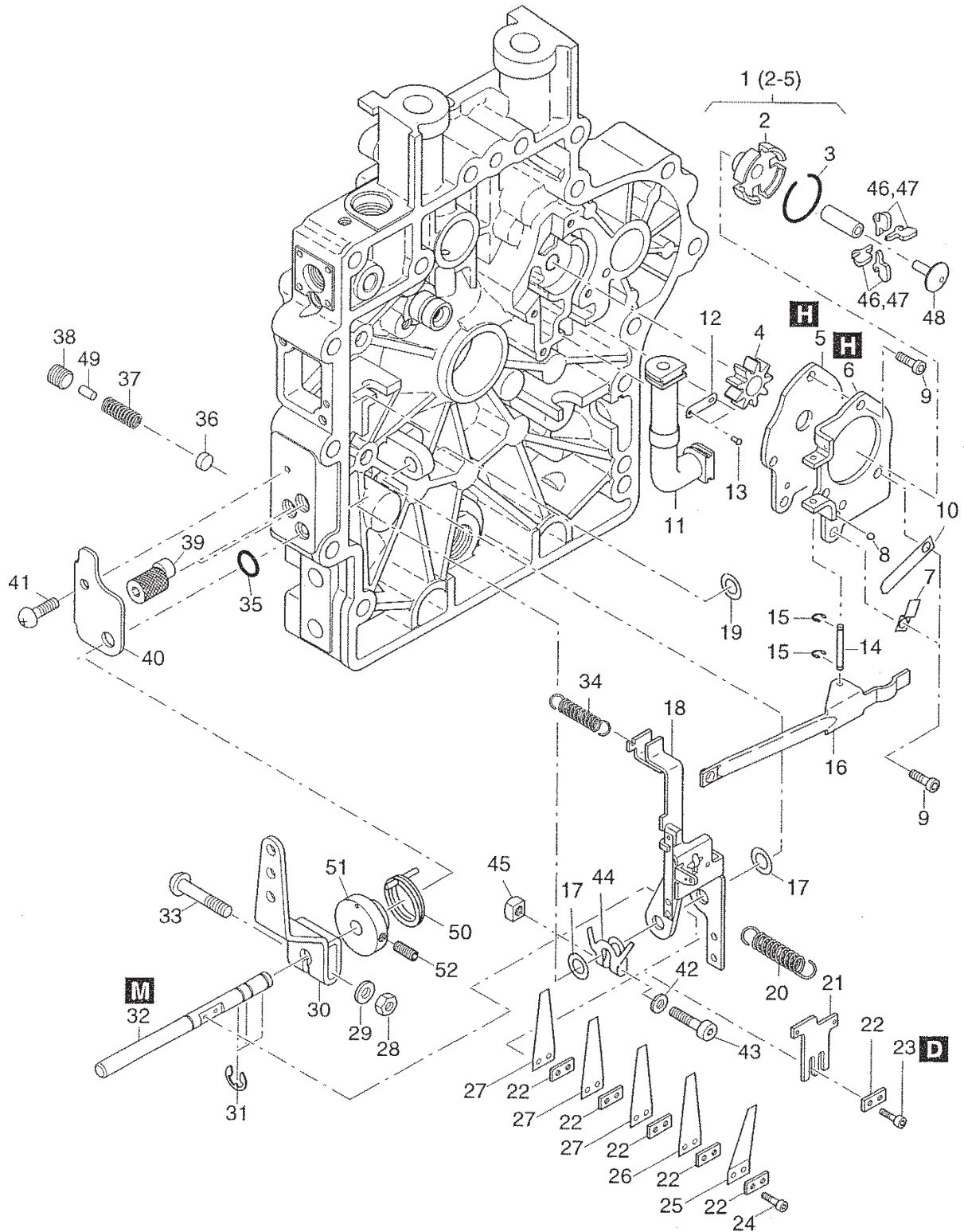

# HATZ 1B40U-2203A — OIL PUMP AND GOVERNOR ASSY.

## OIL PUMP AND GOVERNOR ASSY.

<u>NO.</u>	<u>PART NO.</u>	<u>PART NAME</u>	<u>QTY.</u>	<u>REMARKS</u>
D	50223300	LOCTITE221 50ML	1	
H	50282501	SILICON 30ML	1	
M	50485100	SCHLEIF PASTE 80G	1	
1	01344510	OILPUMP CP. ASSY .....	1	INCLUDES ITEMS W/ #
2#		OIL PUMP .....	1	NOT SOLD SEPARATELY
3#	04210910	CIRCLIP	1	
4#		GEAR, OIL PUMP .....	1	NOT SOLD SEPARATELY
5#		HOUSING, OIL PUMP .....	1	NOT SOLD SEPARATELY
6	05078110	COVER, OIL PUMP	1	
7	05097100	RETAINING STRAP	1	
8	50447900	BALL 3.5 MM G100	1	
9	50429400	ALLEN SCREW M5X12	4	
10	05097300	FLAT SPRING 0.4	1	
11	01346000	TUBE OIL SUCTION	1	
12	04153400	FISHPLATE	1	
13	40002600	BLINDRIVET3.2	2	
14	05078600	SHAFT	1	
15	50434800	CIRCLIP 1.9	2	
16	01345901	LEVER	1	
17	50422400	SHIM 8X14X1	2	
18	01365200	GOVERNOR LEVER	1	
19	50125800	DISC 8X14X0.5	1	
20	05130910	GOVERNOR SPRING	1	
21	05130800	STOP	1	
22	05079800	INTERMEDIATE PLATE	1	
23	50465300	ALLEN SCREW M3X8	2	
24	50435000	ALLEN SCREW M3X12	2	
25	05148600	STOP SPRING	1	

# HATZ 1B40U-2203A — OIL PUMP AND GOVERNOR ASSY.

OIL PUMP AND GOVERNOR ASSY.

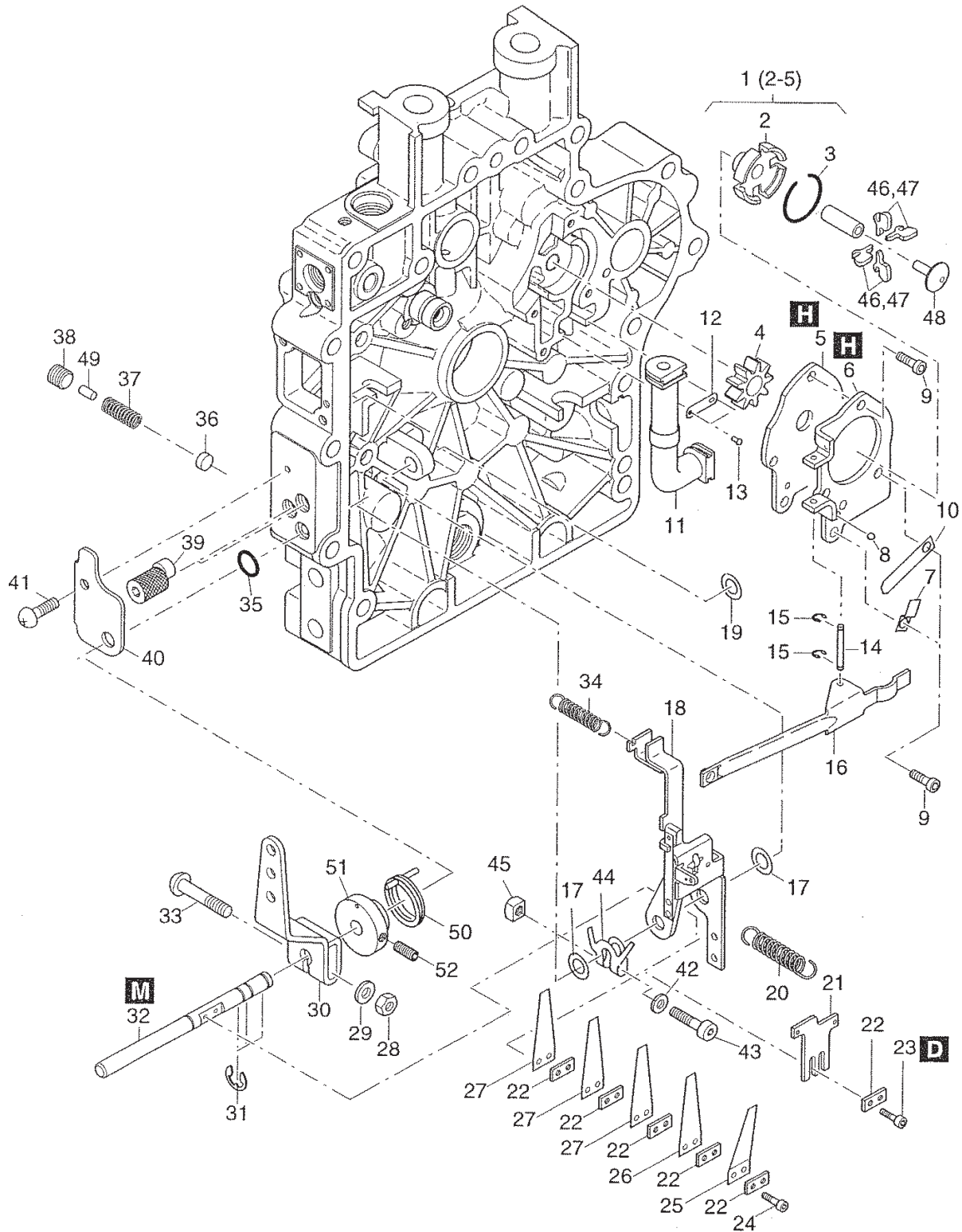

# HATZ 1B40U-2203A — OIL PUMP AND GOVERNOR ASSY. (CONTINUED)

## OIL PUMP AND GOVERNOR ASSY.

<u>NO.</u>	<u>PART NO.</u>	<u>PART NAME</u>	<u>QTY.</u>	<u>REMARKS</u>
26	05078900	GOV. SPRING 0.3	1	
27	05131600	GOV. SPRING 0.2	1	
28	50346500	HEXAGON NUT, M6	1	
29	50144500	FLAT WASHER	1	
30	04095600	LEVER	1	
31	50092700	CIRCLIP 7	1	
32	05079301	SHAFT	1	
33	03927300	SCREW M6 X 32	1	
34	50563400	TENSION SPRING	1	
35	40022401	O-RING 8X2 GRAY	1	
36	05151700	PLUG	1	
37	50488700	PRESSURE SPRING	1	
38	50475700	GRUB SCREW M10X10	4	
39	05178810	ECCENTRIC SCREW	1	
40	05178400	PLATE	1	
41	50492300	FILL.HEAD SCREW M5X12	1	
42	50216300	WASHER 5.3	2	
43	50492200	ALL.SCR. M5X25	1	
44	05178500	STOP	2	
45	50422700	SQUARE NUT M5	1	
46	05079611	CENTRIFUGAL WEIGHT	2	
47	05160211	CENTRIFUGAL WEIGHT	1	
48	05078502	GOVERNOR SLEEVE	1	
49	50057900	CYL.PIN 4 M6X8	1	
50	05179100	SPRING	1	
51	05179000	BUSHING	1	
52	50400600	GRUB SCREW M5 X 10	1	

# HATZ 1B40U-2203A — TIMING COVER ASSY.

TIMING COVER ASSY.

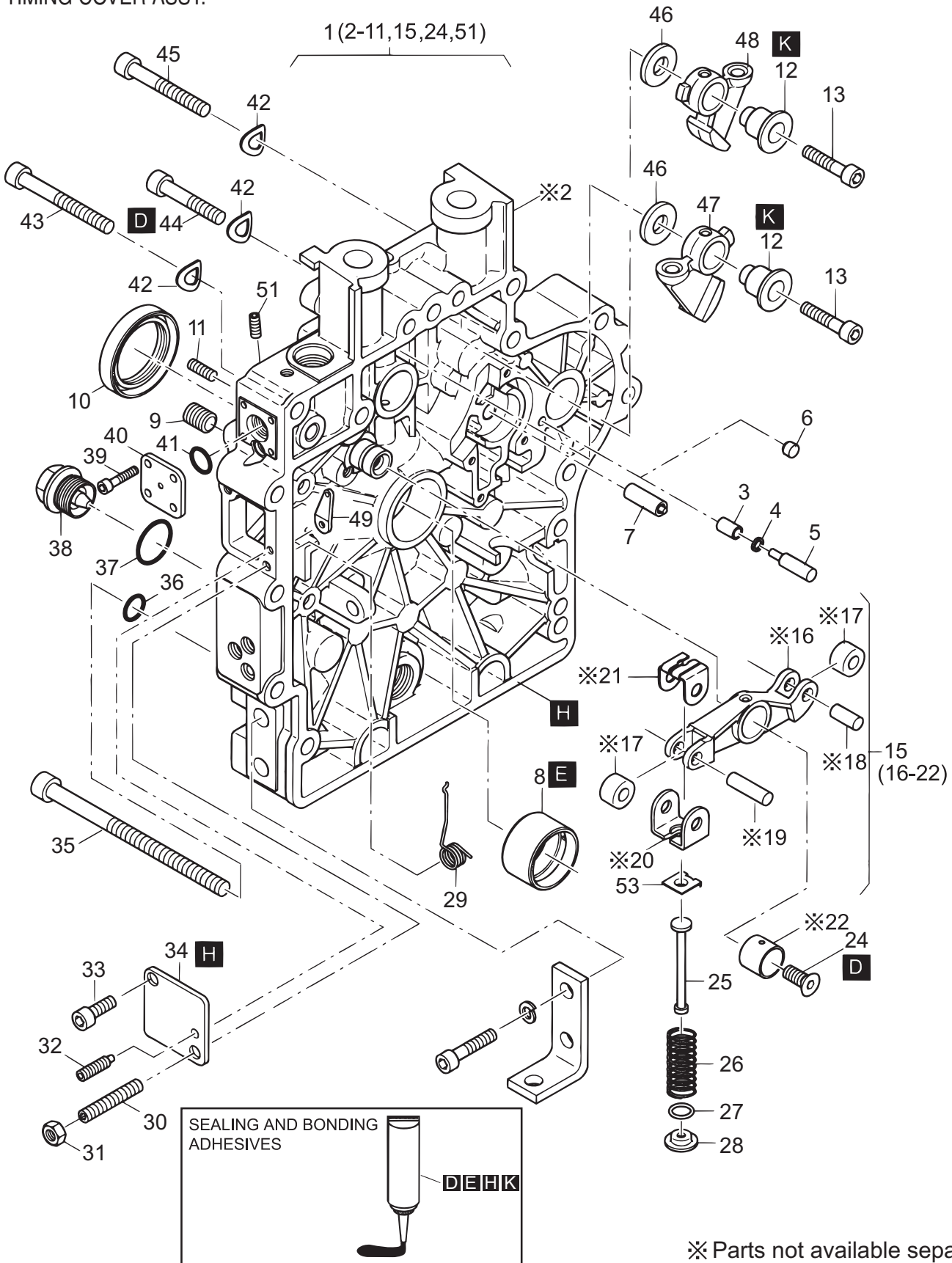

# HATZ 1B40U-2203A — TIMING COVER ASSY.

## TIMING COVER ASSY.

<u>NO.</u>	<u>PART NO.</u>	<u>PART NAME</u>	<u>QTY.</u>	<u>REMARKS</u>
D	50223300	LOCTITE221 50ML	1	
E	50223400	LOCTITE648 10ML	1	
H	50282501	SILICON 30ML	1	
K	50342601	HOCHTEMP.FETT 400G	1	
1	01894200	TIMING COVER CP. ASSY .....	1	INCLUDES ITEMS W/ #
2#		TIMING COVER .....	1	NOT SOLD SEPARATELY
3#	04185800	CLOSING PLUG	1	
4#	50464100	O-RING 2X1	1	
5#	04185700	CLOSING PLUG 4X15	1	
6#	04168600	PLUG 4.3	1	
7#	01344600	BOLT F.GOV.HOUSING	1	
8#	04148800	MAIN BEARING	1	
9#	50530600	GRUB SCREW M8X10	4	
10#	50479500	OIL SEAL 35X47X7	1	
11#	50400600	GRUB SCREW M 5X10	2	
12	03794201	CAM FOLLOW SP.	2	
13	50469900	ALLEN SCREW M6X30	2	
15#	01346710	ROCKER LEVER ASSY .....	1	INCLUDES ITEMS W/ \$
16\$		ROCKER LEVER .....	1	NOT SOLD SEPARATELY
17\$		BUSHING, ROCKER LEVER .....	1	NOT SOLD SEPARATELY
18\$		PIN, ROCKER LEVER .....	1	NOT SOLD SEPARATELY
19\$		PIN, ROCKER LEVER .....	1	NOT SOLD SEPARATELY
20\$		CLAMP, ROCKER LEVER .....	1	NOT SOLD SEPARATELY
21\$		CLAMP, ROCKER LEVER .....	1	NOT SOLD SEPARATELY
22\$		SPINDLE .....	1	NOT SOLD SEPARATELY
24#	50561800	CTR.SUNK SCREW M6X40	1	
25	04094700	DRAW ROD	1	
26	04095700	PRESSURE SPRING	1	

# HATZ 1B40U-2203A — TIMING COVER ASSY.

TIMING COVER ASSY.

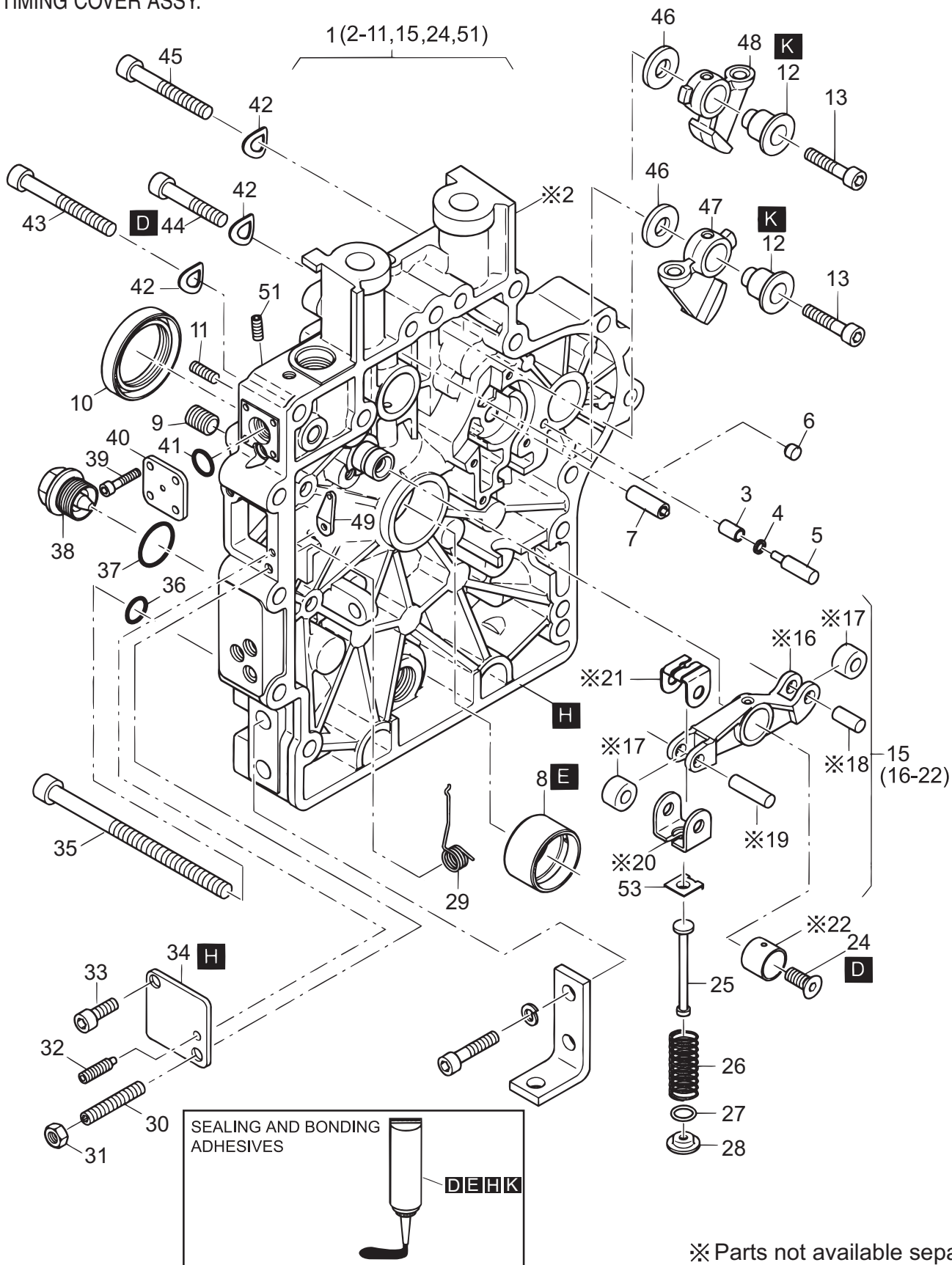

※ Parts not available separately



## HATZ 1B40U-2203A — TIMING COVER ASSY. (CONTINUED)

### TIMING COVER ASSY. (CONTINUED)

<u>NO.</u>	<u>PART NO.</u>	<u>PART NAME</u>	<u>QTY.</u>	<u>REMARKS</u>
27	04133900	DISC 10.7X19X0.5	1	
28	04094802	CUP	1	
29	05095210	SPRING F.GOVERNOR	1	
30	50499300	GRUB SCREW M6X35	1	
31	50144400	HEXAGON NUT M6	1	
32	50499400	GRUB SCREW M4X25	1	
33	50384200	ALLEN SCREW M6X12	1	
34	04095210	COVER	1	
35	50463000	ALLEN SCREW M8X130	2	
36	50162900	JOINT A8X14	2	
37	50459100	JOINT A22X27	1	
38	50373100	DRAIN PLG.MAGNT.M22	1	
39	50397100	ALLEN SCREW M4X10	4	
40	01351700	COVER	1	
41	50329000	O-RING 9.5X2.5	1	
42	50095100	SPRING WASHER A8	15	
43	50288800	ALLEN SCREW M8X55	11	
44	50177500	ALLEN SCREW M8X40	2	
45	50392900	ALLEN SCREW M8X50	2	
46	03794100	WASHER	2	
47	04146600	CAM FOLLOWER	1	
48	04146000	CAM FOLLOWER	1	
49	05127100	LEVER	1	
51#	50262400	THREADED PIN M6X10	1	
53	04189500	CUP	1	

# HATZ 1B40U-2203A — BLOWER AND FLYWHEEL ASSY.

BLOWER, FLYWHEEL ASSY.

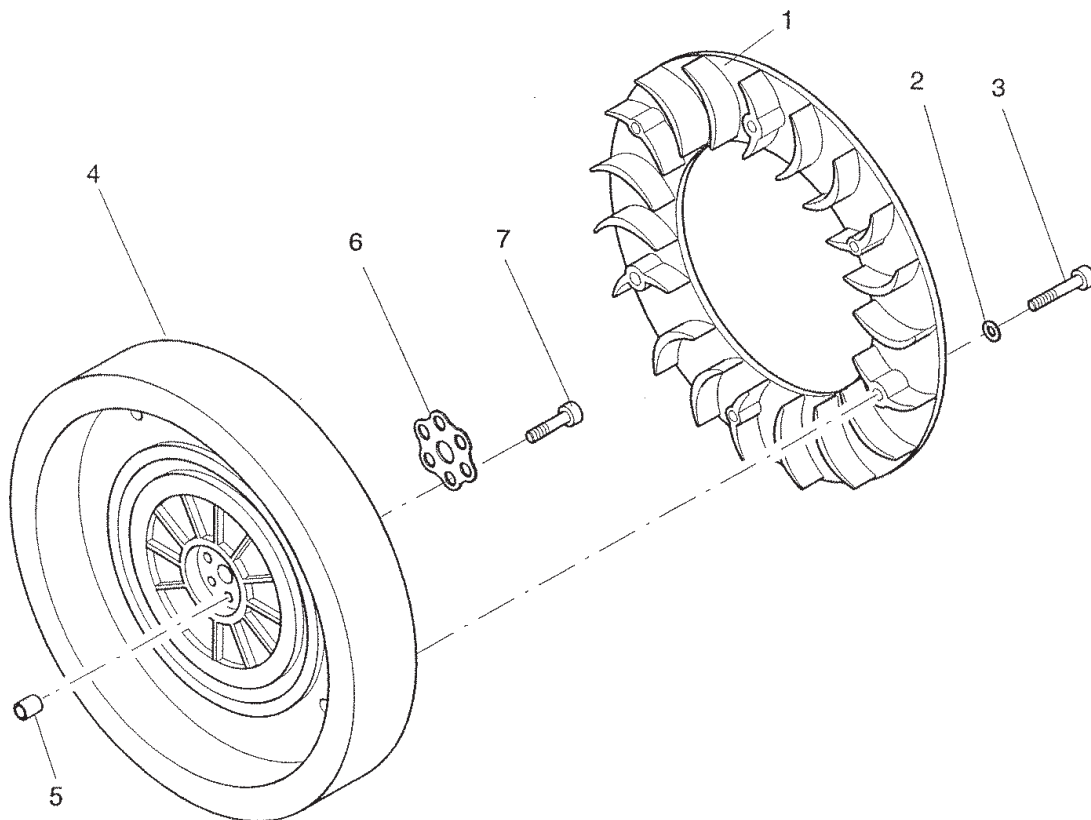

# HATZ 1B40U-2203A — BLOWER AND FLYWHEEL ASSY.

BLOWER, FLYWHEEL ASSY.

<u>NO.</u>	<u>PART NO.</u>	<u>PART NAME</u>	<u>QTY.</u>	<u>REMARKS</u>
1	04205800	BLOWER RING	1	
2	50003400	SPRING WASHER A4	6	
3	50327300	ALLEN SCREW M4X20	6	
4	04153901	FLYWHEEL	1	
5	50205600	ROLL PIN 10 X 12	1	
6	04155101	PLATE	1	
7	50502501	ALLEN SCREW M8X35	6	

# HATZ 1B40U-2203A — INJECTION EQUIPMENT ASSY.

## INJECTION EQUIPMENT ASSY.

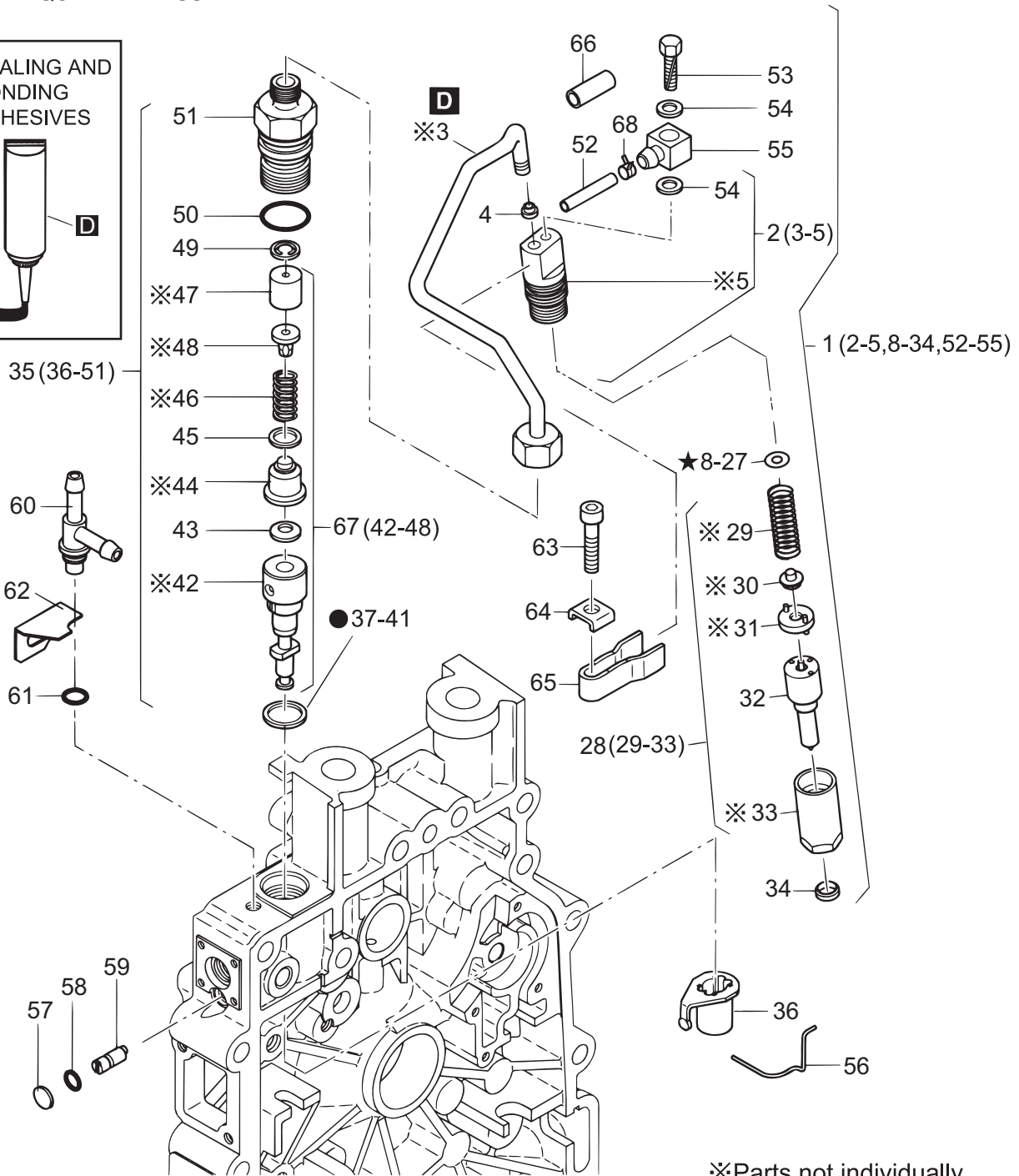
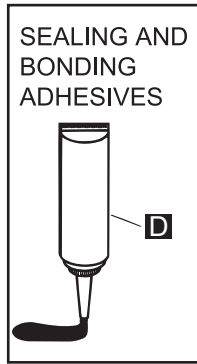

● Use for adjustment	
37	0.2mm
38	0.3mm
39	0.4mm
40	0.5mm
41	0.6mm

★ Use for adjustment					
8	1.00mm	13	1.24mm	18	1.50mm
9	1.04mm	14	1.30mm	19	1.54mm
10	1.10mm	15	1.34mm	20	1.60mm
11	1.14mm	16	1.40mm	21	1.64mm
12	1.20mm	17	1.44mm	22	1.70mm
				23	1.74mm
				24	1.80mm
				25	1.84mm
				26	1.90mm
				27	1.94mm

# HATZ 1B40U-2203A — INJECTION EQUIPMENT ASSY.

## INJECTION EQUIPMENT ASSY.

<u>NO.</u>	<u>PART NO.</u>	<u>PART NAME</u>	<u>QTY.</u>	<u>REMARKS</u>
D	50223300	LOCTITE221 50ML	1	
1	01389700	INJECTOR CPL. ....	1	INCLUDES ITEMS W/ %
2%	01680600	NOZZLE HOLD.+PIPE .....	1	INCLUDES ITEM W/ &
3%&		PIPE .....	1	NOT SOLD SEPARATELY
4%&	05070601	SEALING CONE	1	
5%&		NIPPLE BODY .....	1	NOT SOLD SEPARATELY
8%	50436400	SHIM 1.0	1	
9%	50436500	SHIM 1.04	1	
10%	50436600	SHIM 1.10	1	
11%	50436700	SHIM 1.14	1	
12%	50436800	SHIM 1.20	1	
13%	50436900	SHIM 1.24	1	
14%	50437000	SHIM 1.30	1	
15%	50437100	SHIM 1.34	1	
16%	50437200	SHIM 1.40	1	
17%	50437300	SHIM 1.44	1	
18%	50437400	SHIM 1.50	1	
19%	50437500	SHIM 1.54	1	
20%	50437600	SHIM 1.60	1	
21%	50437700	SHIM 1.64	1	
22%	50437800	SHIM 1.70	1	
23%	50437900	SHIM 1.74	1	
24%	50438000	SHIM 1.80	1	
25%	50438100	SHIM 1.84	1	
26%	50438200	SHIM 1.90	1	
27%	50438300	SHIM 1.94	1	
28%	01389900	PARTS SET NOZZLE ASSY EPA .....	1	INCLUDES ITEMS W/ \$
29\$%		SPRING .....	1	NOT SOLD SEPARATELY
30\$%		SPRING WASHER .....	1	NOT SOLD SEPARATELY
31\$%		PLATE .....	1	NOT SOLD SEPARATELY
32\$%	50566600	NOZZLE	1	
33\$%		BODY .....	1	NOT SOLD SEPARATELY

# HATZ 1B40U-2203A — INJECTION EQUIPMENT ASSY.

## INJECTION EQUIPMENT ASSY.

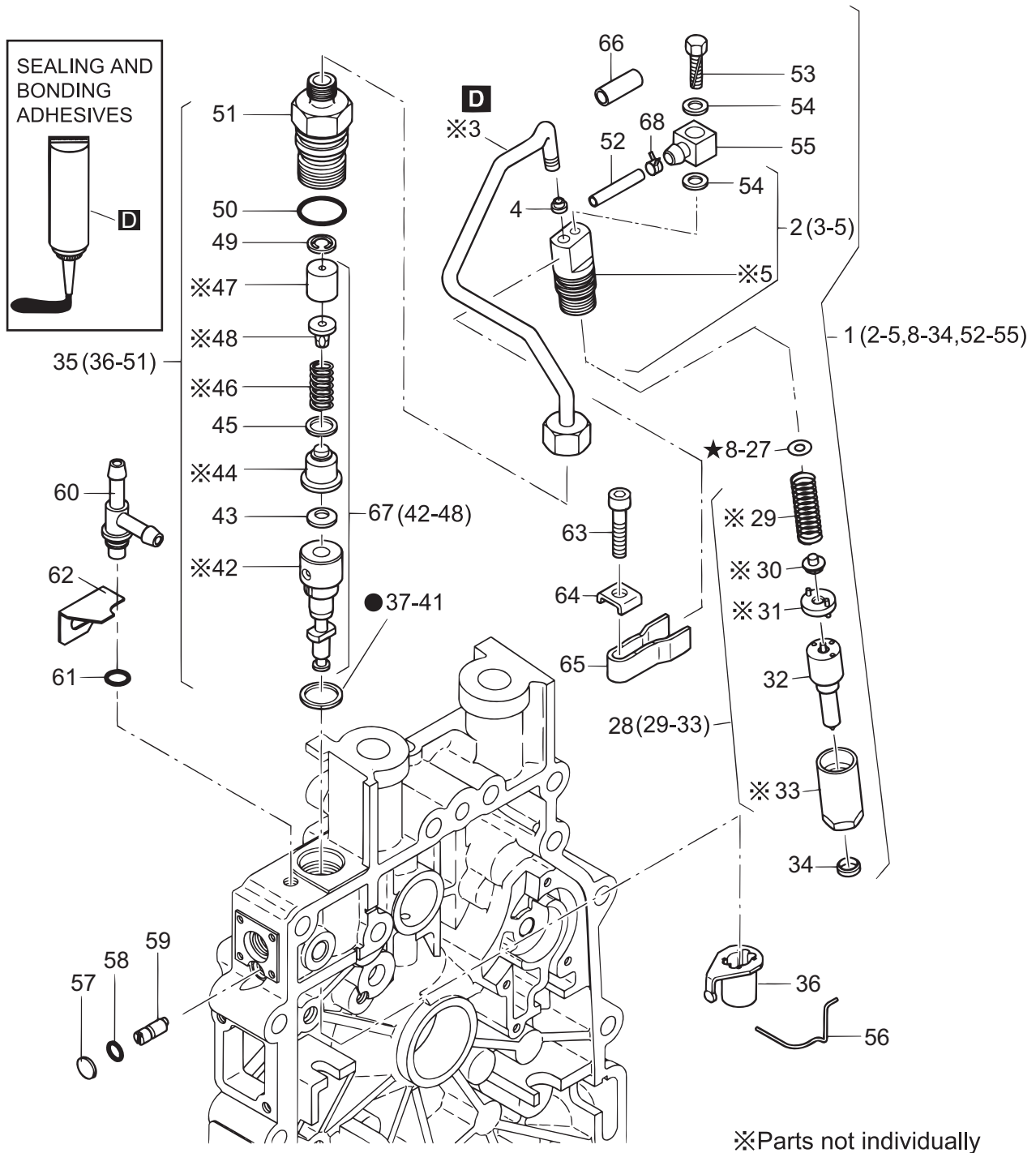

● Use for adjustment

37	0.2mm
38	0.3mm
39	0.4mm
40	0.5mm
41	0.6mm

★ Use for adjustment

8	1.00mm	13	1.24mm	18	1.50mm	23	1.74mm
9	1.04mm	14	1.30mm	19	1.54mm	24	1.80mm
10	1.10mm	15	1.34mm	20	1.60mm	25	1.84mm
11	1.14mm	16	1.40mm	21	1.64mm	26	1.90mm
12	1.20mm	17	1.44mm	22	1.70mm	27	1.94mm

# HATZ 1B40U-2203A — INJECTION EQUIPMENT ASSY.

## INJECTION EQUIPMENT ASSY. (CONTINUED)

<u>NO.</u>	<u>PART NO.</u>	<u>PART NAME</u>	<u>QTY.</u>	<u>REMARKS</u>
34%	05070500	JOINT WASH.F.INJECT	1	
35	01680810	FUEL INJECTOR PUMP CP .....	1	INCLUDES ITEMS W/ @
36@	01330801	CONTROL SLEEVE	1	
37@	04096300	SHIM 14X18X0.2	1	
38@	04096400	SHIM 14X18X0.3	1	
39@	04096500	SHIM 14X18X0.4	1	
40@	04096600	SHIM 14X18X0.5	1	
41@	04096700	SHIM 14X18X0.6	1	
42#@		VALVE, FUEL INJECTOR PUMP .....	1	NOT SOLD SEPARATELY
43#@	04165200	CON.SPR.WASHER 8	1	
44#@		BODY, FUEL INJECTOR PUMP .....	1	NOT SOLD SEPARATELY
45#@	50476900	JOINT WASHER	1	
46#@		SPRING, FUEL INJECTOR PUMP .....	1	NOT SOLD SEPARATELY
47#@		VALVE, FUEL INJECTOR PUMP .....	1	NOT SOLD SEPARATELY
48#@		BODY, FUEL .....	1	NOT SOLD SEPARATELY
49@	05180800	VALVE PLATE	1	
50@	50489200	O-RING 17X2	1	
51@	05181100	DELIV.VALVE HOLDER	1	
52%	05215000	HOSE 2.5X195	1	
53%	50464500	HEXSCREW A M4X16	1	
54%	50110800	JOINT A4X8	2	
55%	05129000	CONNECTING NIPPLE	1	
56	04161800	HOLDING SPRING	1	
57	50476000	DISC 8	1	
58	50330100	O-RING 4X1.2	1	
59	04097710	ECCENTRIC PIN	1	
60	01756800	NIPPLE	1	
61	50154300	O-RING 7.5X10.5X1.5	1	
62	05183100	SUPPORT	1	
63	50323900	ALL.SCR. M6X30	1	
64	05089300	RETAINING YOKE	1	
65	05056700	FORK F. INJECTOR	1	
66	05267900	INSUL.HOSE 120MM	1	
67	01828510	F. INJ.PUMP BODY .....	1	INCLUDES ITEMS W/ #
68	50577900	CLAMP 0.5X6.0XA6.0	1	

# HATZ 1B40U-2203A — RECOIL STARTER ASSY.

## RECOIL STARTER ASSY.

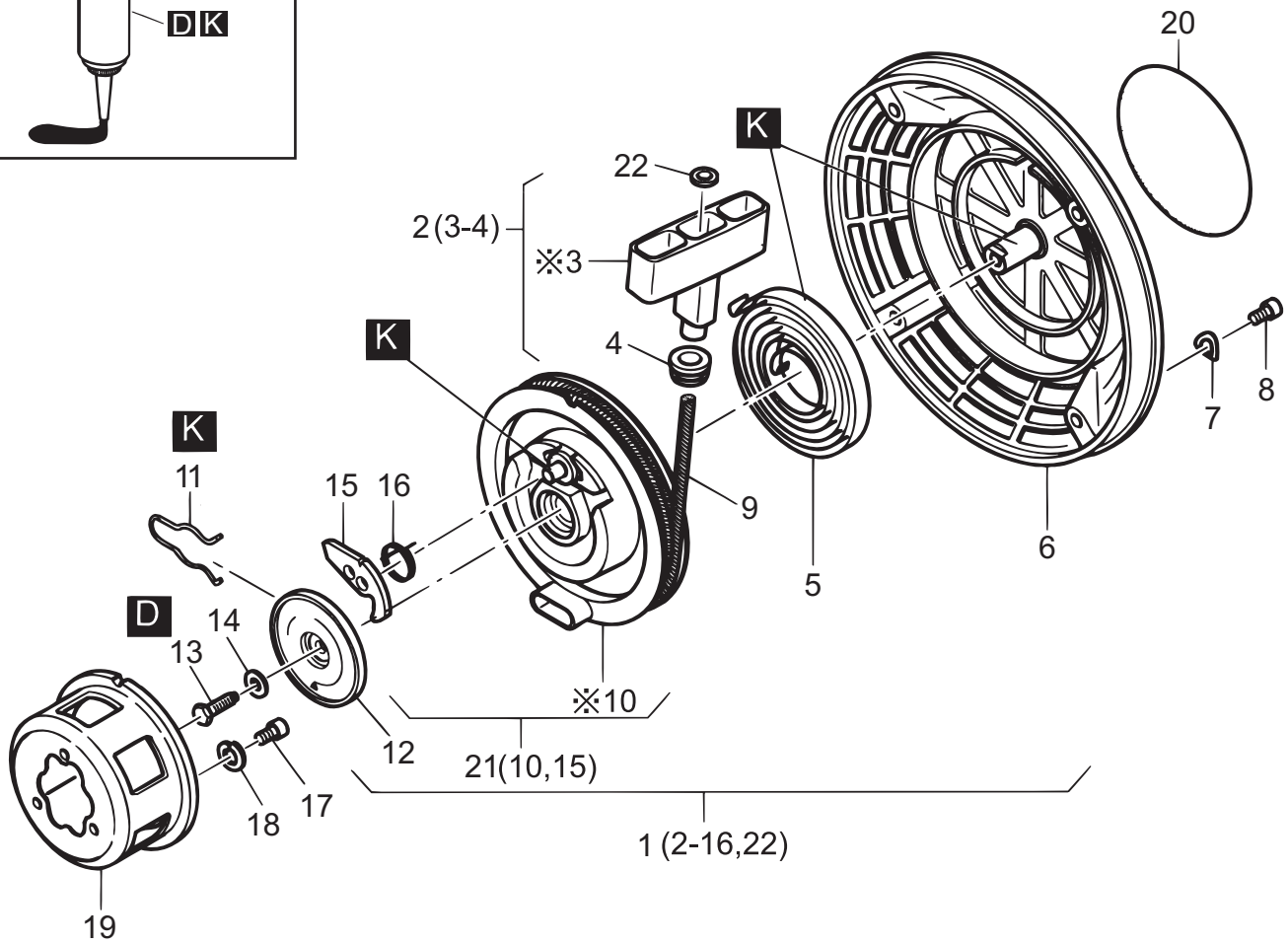

※ Not available separately



# HATZ 1B40U-2203A — RECOIL STARTER ASSY.

## RECOIL STARTER ASSY.

<u>NO.</u>	<u>PART NO.</u>	<u>PART NAME</u>	<u>QTY.</u>	<u>REMARKS</u>
D	50223300	LOCTITE221 50ML	1	
K	50342601	HOCHTEMP.FETT 400G	1	
1	01851900	RECOIL-STARTER .....	1	INCLUDES ITEMS W/ %
2%	01497800	HANDLE ASSY. ....	1	INCLUDES ITEMS W/ #
3%#		HANDLE .....	1	NOT SOLD SEPARATELY
4%#	03665200	RUBBER SLEEVE	1	
5%	05045201	RETURN SPRING	1	
6%	01569300	HOUSING F.R.START	1	
7%	50081200	SPRING WASHER A6	4	
8%	50062700	ALLEN SCREW M6X10	4	
9%	05088901	ROPE F.R.START	1	
10%\$		ROPE PULLEY .....	1	NOT SOLD SEPARATELY
11%	05044901	BRAKE SPRING	1	
12%	05045001	BRAKE DISC	1	
13%	50146300	HEX SCREW M6X18	1	
14%	50390701	CON.SPR.WASHER 6	1	
15%\$	05044800	RATCHET	1	
16%	05061300	RETURN SPRING	1	
17	50062700	ALLEN SCREW M6X10	3	
18	50170900	SPRING WASHER 6	3	
19	04155000	DRIVING SLEEVE	1	
20	05298100	STICKER LABEL	1	
21	01548800	ROPE PULLEY .....	1	INCLUDES ITEM W/ \$
22%	50514600	WASHER 5.3	1	

# HATZ 1B40U-2203A — AIR DUCTING ASSY. (A)

AIR DUCTING ASSY. (A)

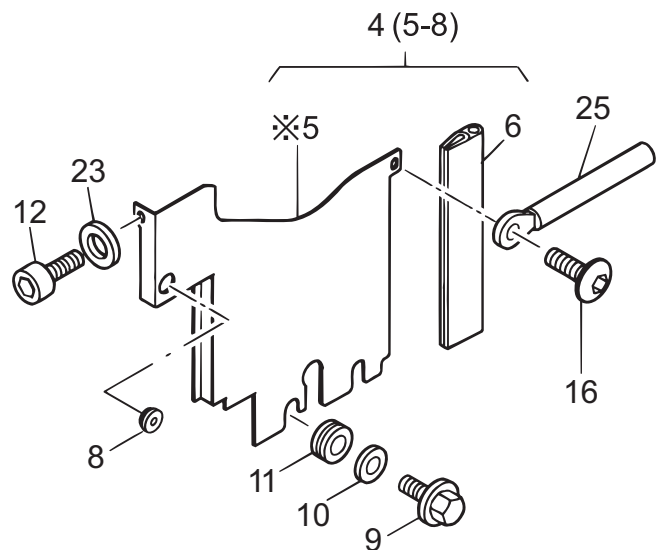
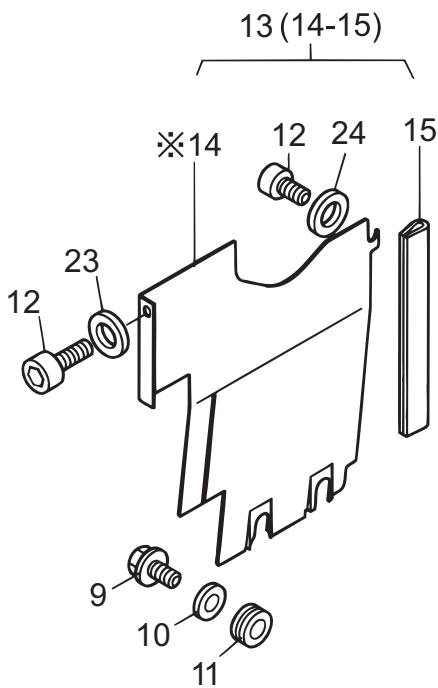
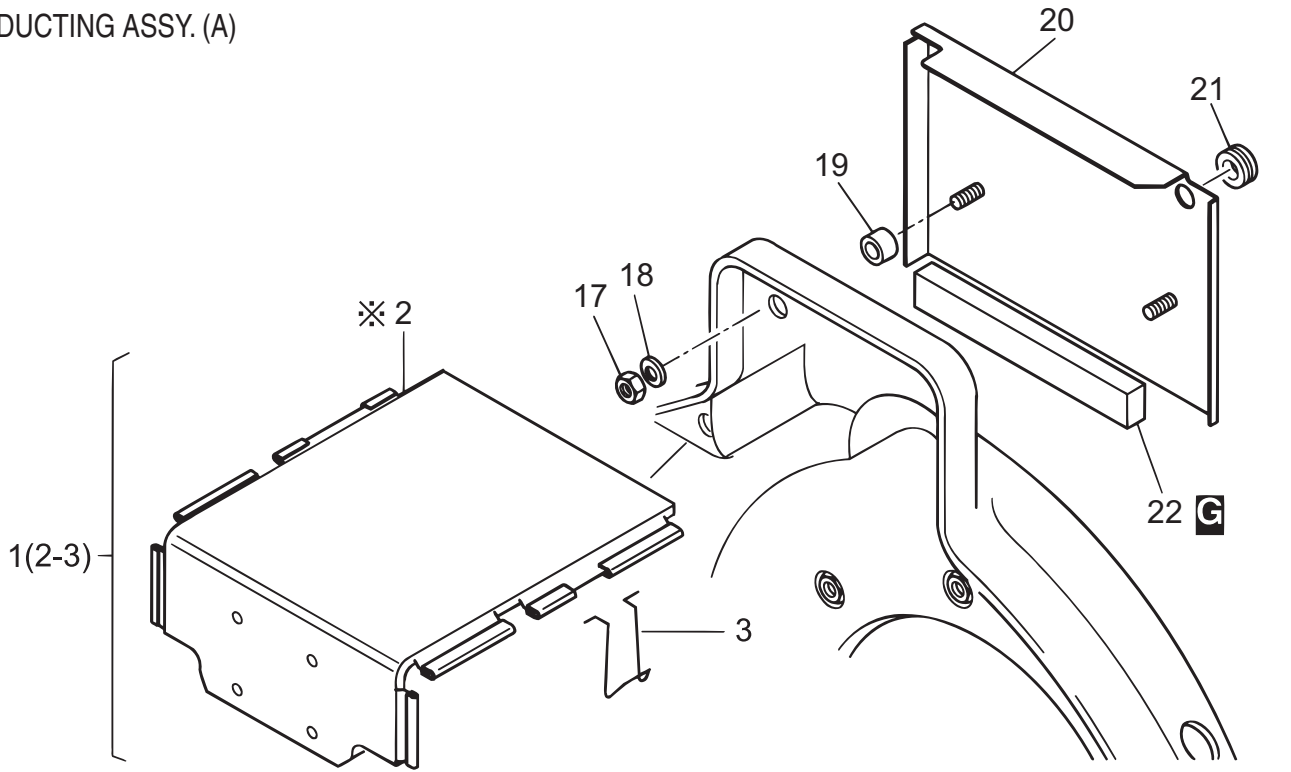

※ Parts not available separately

# HATZ 1B40U-2203A — AIR DUCTING ASSY. (A)

## AIR DUCTING ASSY. (A)

<u>NO.</u>	<u>PART NO.</u>	<u>PART NAME</u>	<u>QTY.</u>	<u>REMARKS</u>
G	50256501	LOCTITE IS407 20G	1	
1	01853100	HOOD ASSY .....	1	INCLUDES ITEM W/ #
2#		HOOD .....	1	NOT SOLD SEPARATELY
3#	05152100	SPRING CLIP	1	
4	01345400	COOLING AIR DUCT ASSY .....	1	INCLUDES ITEM W/ \$
5\$		AIR DUCT .....	1	NOT SOLD SEPARATELY
6\$	04144200	SEALING STRIP 119MM	1	
8\$	50334800	RUBBER SLEEVE	1	
9	50445401	FILL.HEAD SCREW M4X10	4	
10	50441600	WASHER 4.3	4	
11	50163801	RUBBER SLEEVE	4	
12	50528100	ALLEN SCREW M6X16	3	
13	01345300	COOLING AIR DUCT ASSY .....	1	INCLUDES ITEMS W/ %
14%		AIR DUCT .....	1	NOT SOLD SEPARATELY
15%	04144200	SEALING STRIP 119MM	1	
16	50495000	SCREW M6X12	1	
17	50144400	HEXAGON NUT M6	2	
18	50170900	SPRING WASHER 6	2	
19	03354600	SPACER BUSH	2	
20	01698200	COVER	1	
21	50334800	RUBBER SLEEVE	1	
22	03577200	SEALING STRIP	1	
23	50144500	FLAT WASHER 6.4	2	
24	04060600	WASHER 6.4X16X1.5	1	
25	05001200	CLIP	1	

# HATZ 1B40U-2203A — AIR DUCTING ASSY. (B)

AIR DUCTING ASSY. (B)

1 (2,4-7,39)

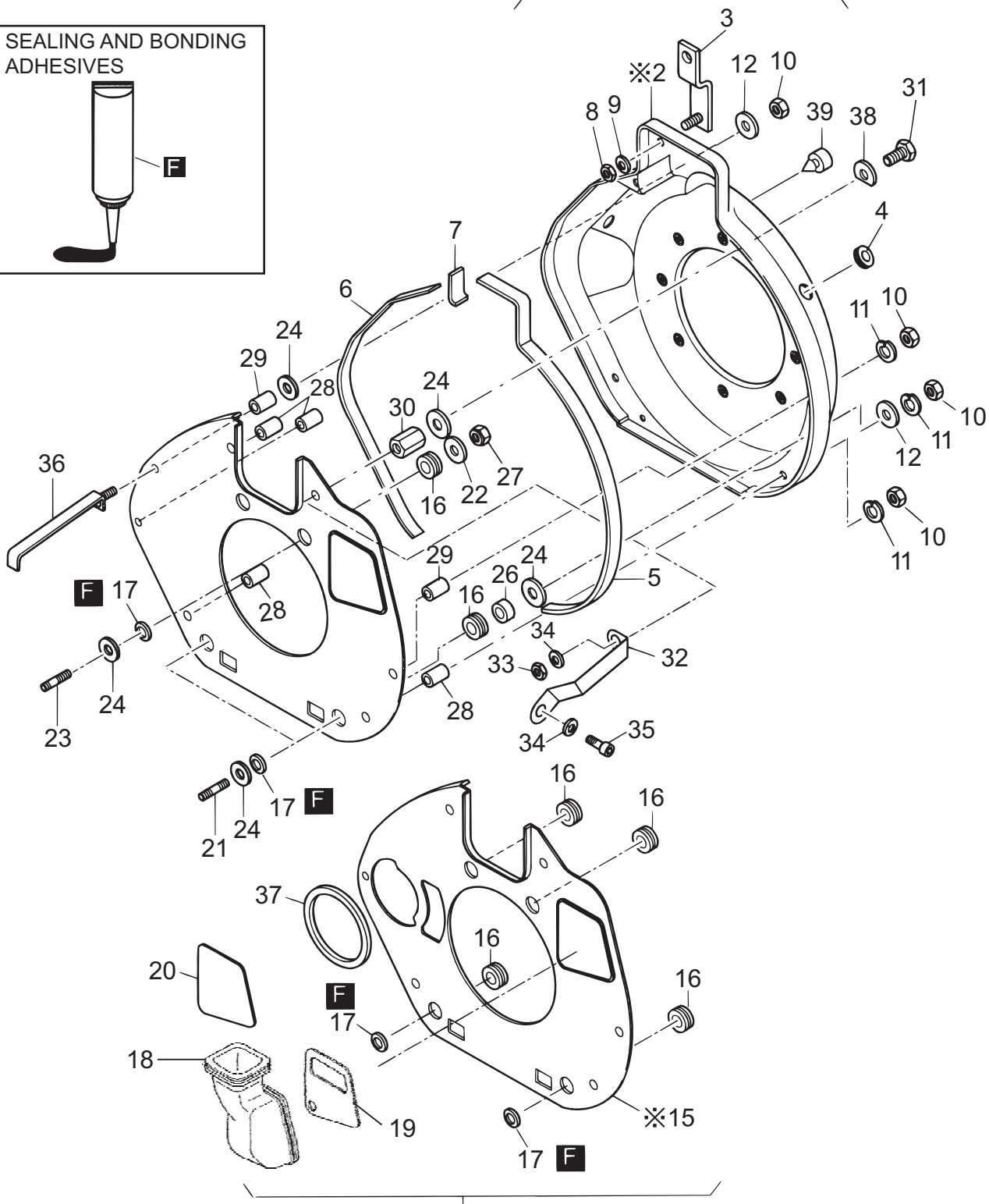
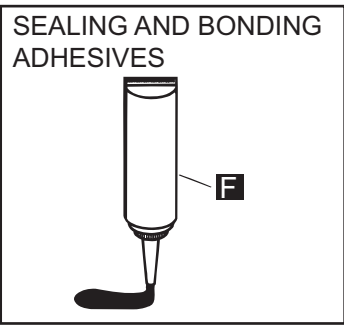

13 (15-17,20)  
14 (15-17,20,37)

※ Parts not available separately

# HATZ 1B40U-2203A — AIR DUCTING ASSY. (B)

## AIR DUCTING ASSY. (B)

<u>NO.</u>	<u>PART NO.</u>	<u>PART NAME</u>	<u>QTY.</u>	<u>REMARKS</u>
F	50223800	TECHNICOLL8058 0.75KG	1	
1	01831300	BLOWER DUCTING ASSY .....	1	INCLUDES ITEMS W/ #
2#		BLOWER DUCTING .....	1	NOT SOLD SEPARATELY
3	01331300	SUPPORT	2	
4#	50453300	RUBBER SLEEVE	1	
5#	05189400	SEALING STRIP 655MM	1	
6#	05189300	SEALING STRIP	1	
7#	05227000	SEALING STRIP 54MM	1	
8	50144400	HEXAGON NUT M6	2	
9	50170900	SPRING WASHER 6	2	
10	50144400	HEXAGON NUT M6	7	
11	50170900	SPRING WASHER 6	8	
12	50120000	DISC A6.4	3	
13	01661900	PARTING SHEET ASSY .....	1	INCLUDES ITEMS W/ \$
14	01347600	PARTING SHEET ASSY E-ST.NO FT .....	1	INCLUDES ITEMS W/ %
15\$%		PARTING SHEET .....	1	NOT SOLD SEPARATELY
16\$%	01378300	SPACER BUSH	4	
17\$%	03575500	RUBBER SEAL RING	4	
18	04146800	RUBBER INSERT	1	
19	04150800	COVER, RUBBER INSERT	1	
20\$%	04215200	CLOSING COVER	1	
21	50458100	STUD M6 X45	2	
22	50114300	DISC 6.4	2	
23	50464401	STUD M6FO X35	2	
24	04042000	WASHER 6.5X22.5X1	7	
26	05188600	SPACER BUSH 7X12X7	2	
27	50328300	HEXAGON NUT VM6	2	
28	04139000	SPAC.TUBE 6.5X12X18	4	
29	04098400	SPAC.TUBE 7X12X16.3	2	
30	05184000	HEXAGON NUT M6X17	1	
31	50026400	HEXSCREW M6X35	1	
32	01669400	SUPPORT	1	
33	50144400	HEXAGON NUT M6	1	
34	50170900	SPRING WASHER 6	2	
35	50170700	ALLEN SCREW M6X16	1	
36	01683300	SUPPORT	1	
37%	04099500	SEALING RING	1	
38	05140900	WASHER	1	
39#	50392610	RUBBER BUSH	1	

# HATZ 1B40U-2203A — CRANKCASE BREATHING SYSTEM ASSY.

CRANKCASE BREATHING SYSTEM ASSY.

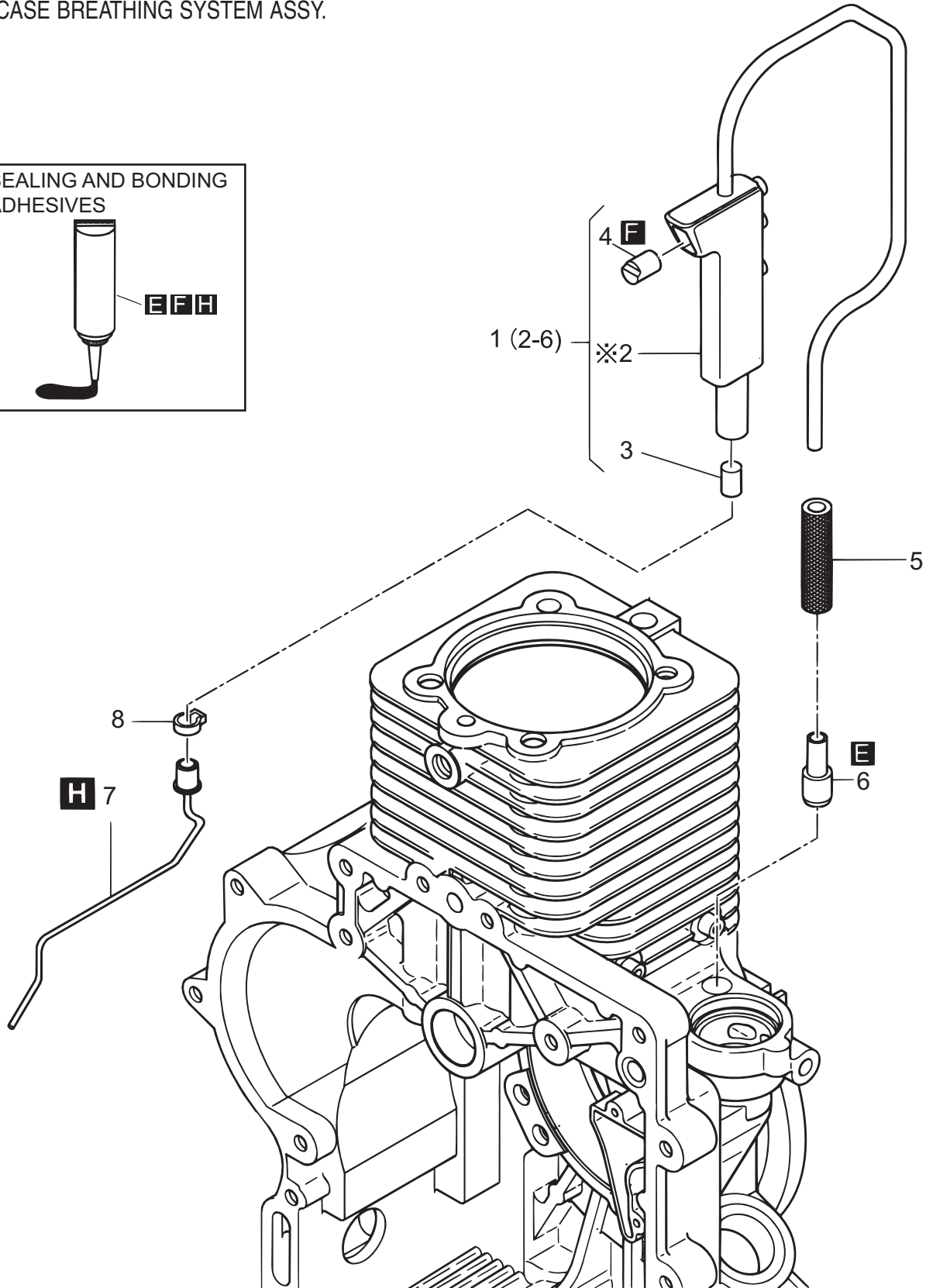

※ Parts not available separately

# HATZ 1B40U-2203A — CRANKCASE BREATHING SYSTEM ASSY.

## CRANKCASE BREATHING SYSTEM ASSY.

<u>NO.</u>	<u>PART NO.</u>	<u>PART NAME</u>	<u>QTY.</u>	<u>REMARKS</u>
E	50223400	LOCTITE648 10ML	1	
F	50223800	TECHNICOLL8058 0.75KG	1	
H	50282501	SILICON 30ML	1	
1	01885800	CRANKCASE BREATHER CP .....	1	INCLUDES ITEMS W/ #
2#		OIL SEPARATOR .....	1	NOT SOLD SEPARATELY
3#	05102900	FILTER BREATHING SYSTEM	1	
4#	05098100	PLUG	1	
5#	05197200	FUEL PIPE LW 7X35	1	
6#	05196000	NIPPLE	1	
7	01626900	SUCTION PIPE	1	
8	50456800	CLAMP	1	

# HATZ 1B40U-2203A — FUEL TANK ASSY.

## FUEL TANK ASSY.

SEALING AND BONDING ADHESIVES

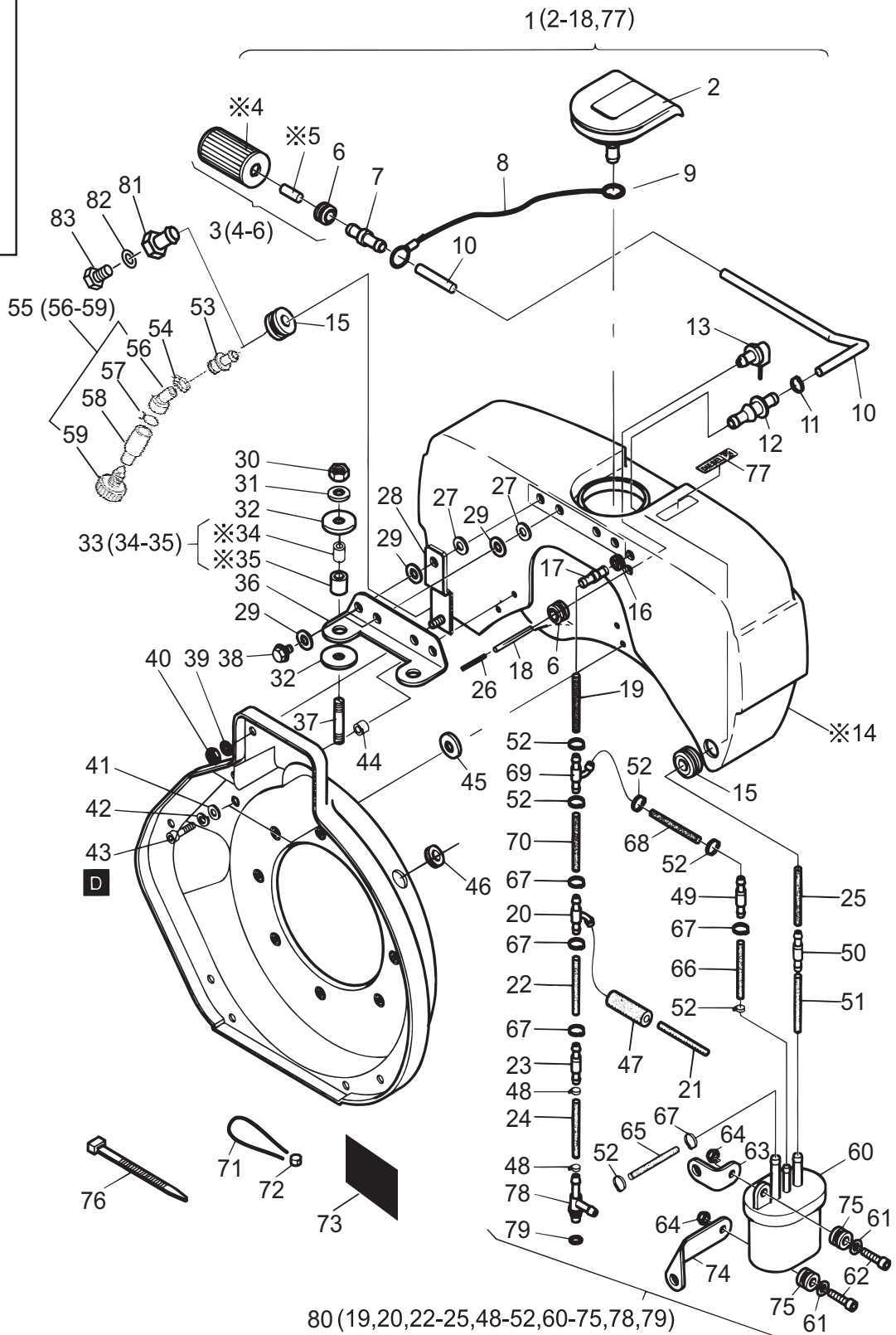
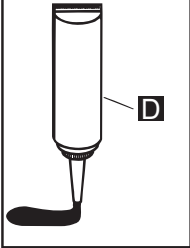

※ Parts not available separately



# HATZ 1B40U-2203A — FUEL TANK ASSY.

## FUEL TANK ASSY.

<u>NO.</u>	<u>PART NO.</u>	<u>PART NAME</u>	<u>QTY.</u>	<u>REMARKS</u>
D	50223300	LOCTITE221 50ML	1	
1	01853200	FUEL TANK ASSY 5L F.SEP. ....	1	INCLUDES ITEMS W/ #
2#	01535302	CAP F. FUEL TANK	1	
3#	01635210	FUEL FILTER ASSY. ....	1	INCLUDES ITEMS W/ \$
4#		FUEL FILTER .....	1	NOT SOLD SEPARATELY
5#		SPACER .....	1	NOT SOLD SEPARATELY
6#	50440901	RUBBER SLEEVE	2	
7#	05189001	CONNECTING NIPPLE	1	
8#	01628900	ROPE	1	
9#	50500800	CIRCLIP 8	1	
10#	05160700	FUEL HOSE 3.5X340	1	
11#	50399801	CLAMP 11.3	1	
12#	05084010	CONNECTING NIPPLE	1	
13#	01534900	FUEL VENT. VALVE	1	
14#		FUEL TANK .....	1	NOT SOLD SEPARATELY
15#	50440800	RUBBER SLEEVE	2	
16#	05130400	RUBBER SLEEVE	1	
17#	05184400	CONNECTING NIPPLE	1	
18#	05189700	BREATHER HOSE	1	
19%	05289300	FUEL HOSE 5.0X50	1	
20%	05175601	HOSE NIPPLE T	1	
21	05215000	HOSE 2.5X195	1	
22%	03664210	HOSE 5X130	1	
23%	01534601	FUEL VENTG. VALVE	1	
24%	05214800	FUEL HOSE 4.5X40	1	
25%	05284010	FUEL HOSE 3.5X160	1	
26	05190900	TUBE	1	
27	50120000	DISC A 6.4	4	
28	01331300	SUPPORT	2	
29	05110010	DISC 7.1X17.9X2	10	
30	40028400	HEX NUT M 8	2	
31	50148100	FLAT WASHER 8.4	2	
32	05109810	DISC 8.2X22X2	4	
33	01655800	INSULATING TUBE .....	2	INCLUDES ITEMS W/ &
34&		INSULATING SLEEVE .....	1	NOT SOLD SEPARATELY
35&		RUBBER SHELL .....	1	NOT SOLD SEPARATELY
36	05170110	SUPPORT	1	
37	50231900	STUD M8X25	2	
38	01557000	HEXSCREW M6X16	4	
39	50170900	SPRING WASHER 6	2	
40	50144000	HEXSCREW M8X40	2	
41	50120000	DISC A6.4	4	
42	50170900	SPRING WASHER 6	4	
43	50170700	ALLEN SCREW M6X16	4	
44	04118800	DISC 6.5X13X4.8	2	
45	04042000	WASHER 6.5X22.5X1	2	

# HATZ 1B40U-2203A — FUEL TANK ASSY.

## FUEL TANK ASSY.

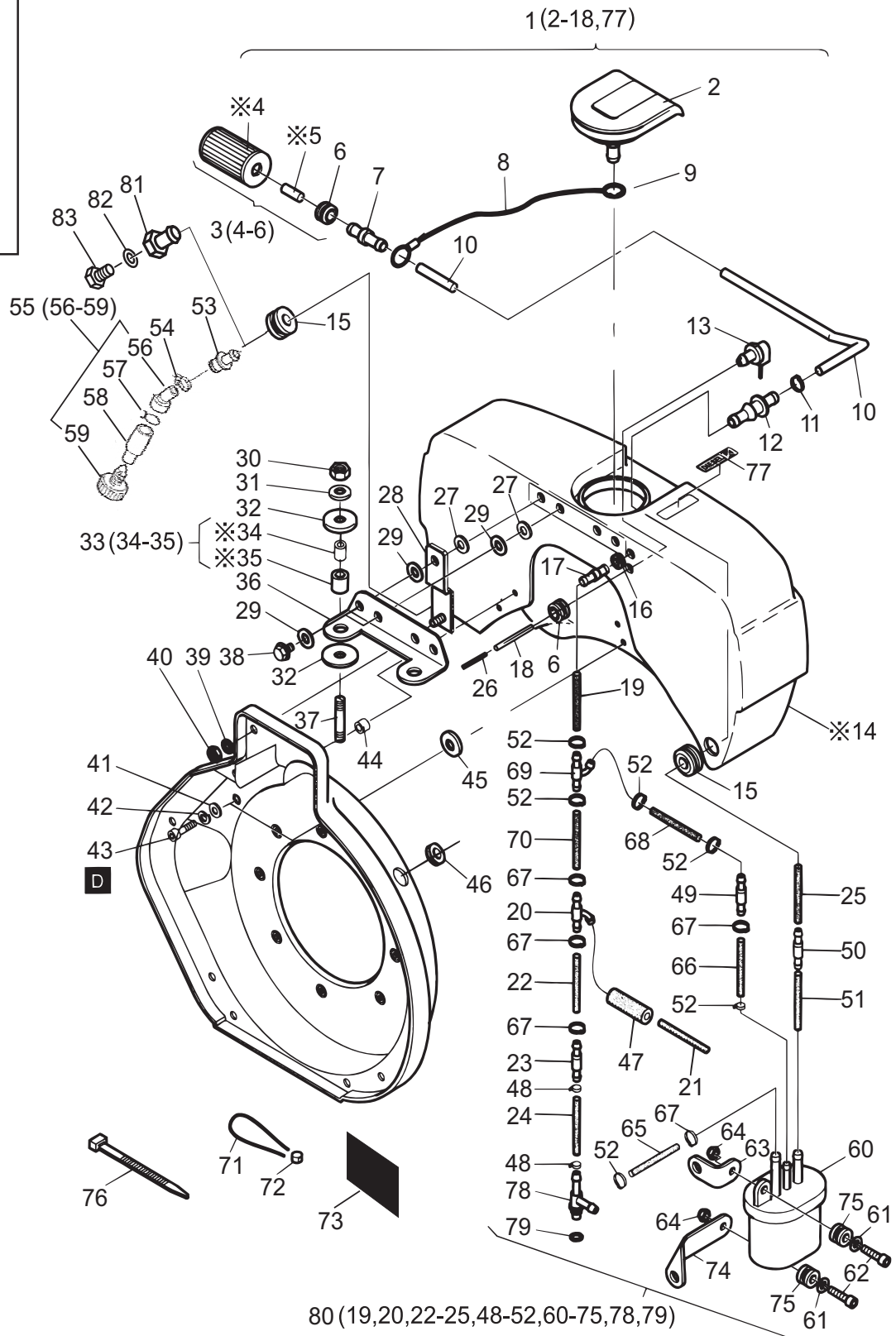
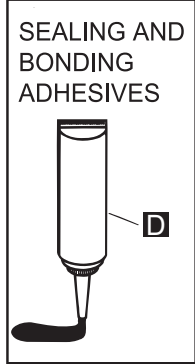

※ Parts not available separately

# HATZ 1B40U-2203A — FUEL TANK ASSY.

## FUEL TANK ASSY. (CONTINUED)

<u>NO.</u>	<u>PART NO.</u>	<u>PART NAME</u>	<u>QTY.</u>	<u>REMARKS</u>
46	50453300	RUBBER SLEEVE	1	
47	05213010	FUEL HOSE 7X25	1	
48%	50441100	HOSE CLIP	2	
49%	00805502	VENT VALVE	1	
50%	05301200	NIPPLE	1	
51%	03663710	FUEL HOSE 5.0/50	1	
52%	50399801	CLAMP 11.3	6	
53	05172300	CONNECTING NIPPLE	1	
54	50448000	CLAMP	1	
55	01519402	WATER SEPARATOR	1	
56	05044001	HOSE 20/12 MM	1	
57	05036900	HOSE CLIP	1	
58	05043901	WATER SEPARATOR	1	
59	50414800	CLOS. SCREW M10	1	
60%	50539200	FUEL FILT. EXT. MOUNT	1	
61%	50441600	WASHER 4.3	2	
62%	50446900	ALLEN SCREW M4X16	2	
63%	05279500	SUPPORT	1	
64%	50501600	HEX NUT M 4	2	
65%	03663610	FUEL HOSE 5X330	1	
66%	03663610	FUEL HOSE 5X330	1	
67%	50570900	CLAMP 12.8	5	
68%	05289300	FUEL HOSE 5.0X50	1	
69%	05122701	HOSE NIPPLE		

# HATZ 1B40U-2203A — AIR FILTER ASSY.

AIR FILTER ASSY.

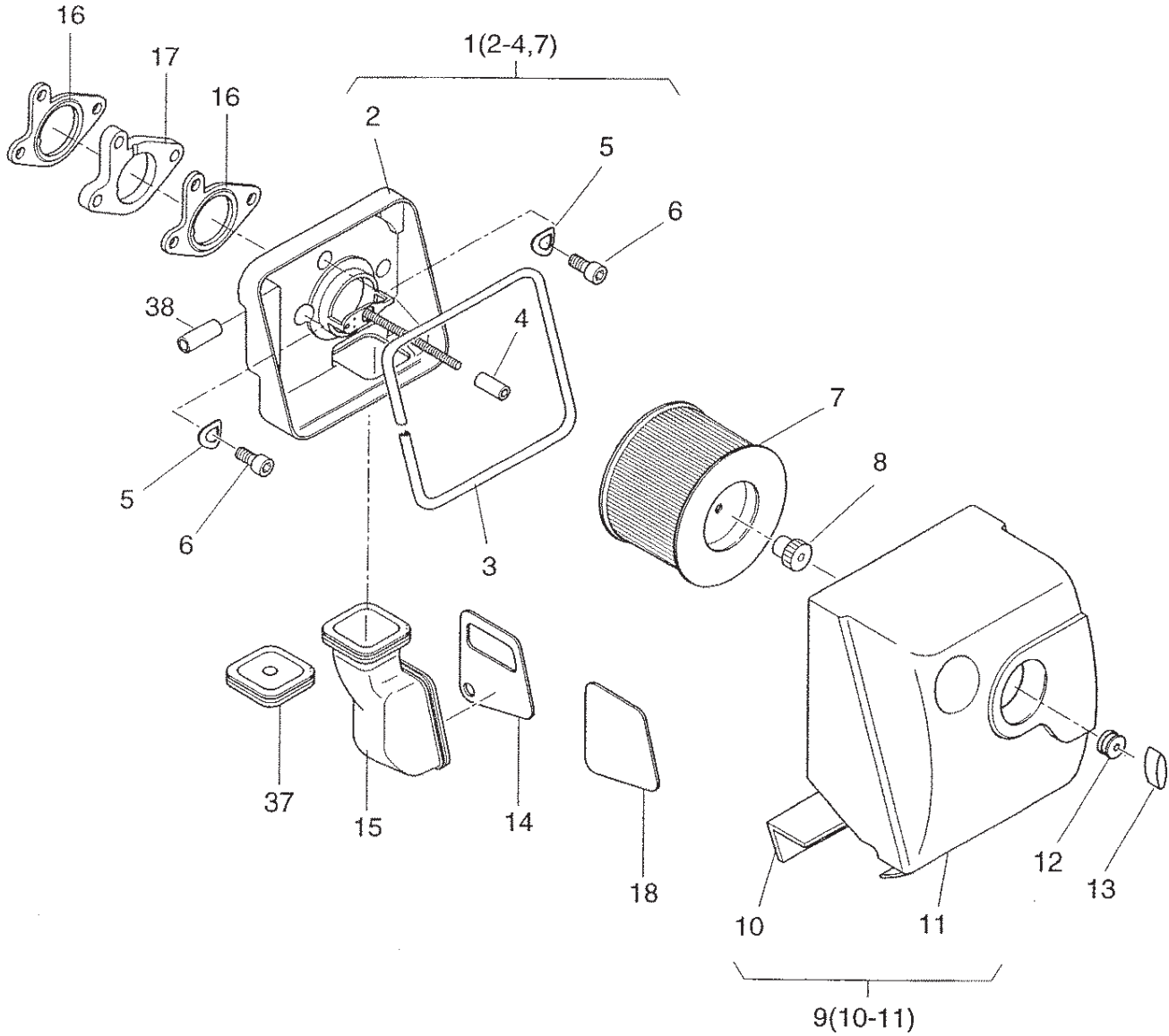

# HATZ 1B40U-2203A — AIR FILTER ASSY.

## AIR FILTER ASSY.

<u>NO.</u>	<u>PART NO.</u>	<u>PART NAME</u>	<u>QTY.</u>	<u>REMARKS</u>
1	01637410	AIR FILTER HOUSING ASSY .....	1 .....	INCLUDES ITEMS W/ #
2#		AIR FILTER HOUSING .....	1 .....	NOT AVAILABLE SEPARATELY
3#	05167700	SEALING STRIP 665MM	1	
4#	05166200	RUBBER SHELL 32MM	1	
5	50095100	SPRING WASHER A8	3	
6	50171500	ALLEN SCREW M 8X 25	3	
7#	50484100	AIR FILTER ELEMENT	1	
8	50454300	KNURLED NUT M6	1	
9	01822000	COVER ASSY, AIR FILTER .....	1 .....	INCLUDES ITEMS W/ \$
10\$	05158000	SEALING STRIP	1	
11\$		COVER, AIR FILTER .....	1 .....	NOT AVAILABLE SEPARATELY
12	50435800	RUBBER SLEEVE	1	
13	50452200	WING NUT M6	1	
14	04150800	COVER, RUBBER INSERT	1	
15	04146800	RUBBER INSERT	1	
16	05149900	GASKET AIR FILTER	2	
17	05149800	INSULATING FLANGE	1	
18	04215200	CLOSING COVER	1	
37	04215300	CLOSING COVER	1	
38	05309300	BREATHER TUBE	1	

# HATZ 1B40U-2203A — EXHAUST SILENCER ASSY.

EXHAUST SILENCER ASSY.

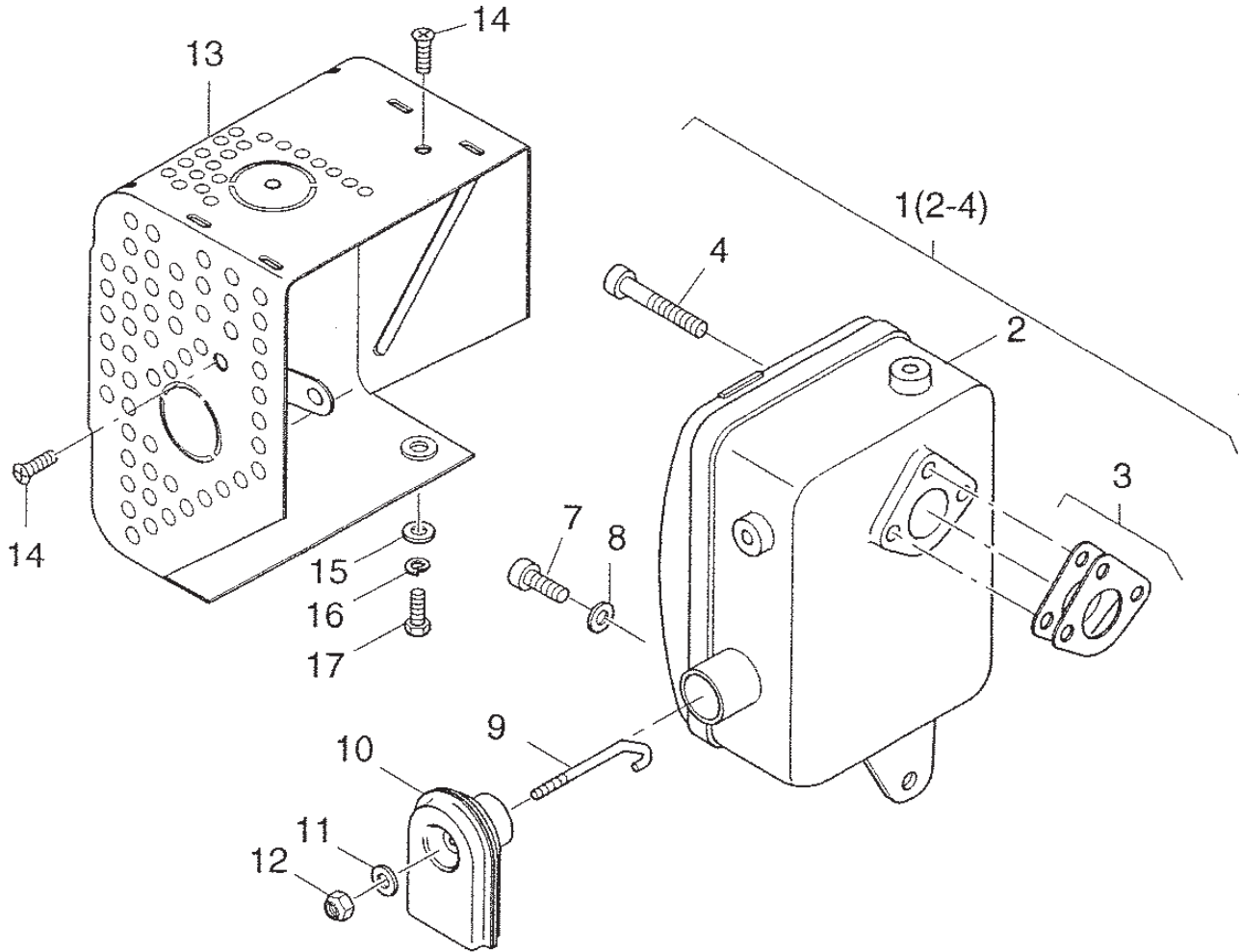

# HATZ 1B40U-2203A — EXHAUST SILENCER ASSY.

## EXHAUST SILENCER ASSY.

<u>NO.</u>	<u>PART NO.</u>	<u>PART NAME</u>	<u>QTY.</u>	<u>REMARKS</u>
1	01682501	EXHAUST SILENCER ASSY .....	1 .....	INCLUDES ITEMS W/ #
2#		EXHAUST SILENCER .....	1 .....	NOT SOLD SEPARATELY
3#	01732701	GASKET MUFFLER	1	
4#	50403900	ALLEN SCREW M8X25	3	
7	50474200	ALLEN SCREW M6X16	1	
8	50114300	DISC 6.4	1	
9	05177900	THREADED BOLT M6	1	
10	01655601	EXHAUST END PIPE	1	
11	50144500	FLAT WASHER	1	
12	40028300	HEX NUT M6	1	
13	01629000	PROTECT. GUARD EXHAUST	1	
14	50422500	CTR. SUNK SCREW M6X12	2	
15	50114300	DISC 6.4	1	
16	50170900	SPRING WASHER 6	1	
17	50177100	HEX SCREW M6X16	1	

# HATZ 1B40U-2203A — STARTER, ALTERNATOR ASSY.

STARTER, ALTERNATOR ASSY.

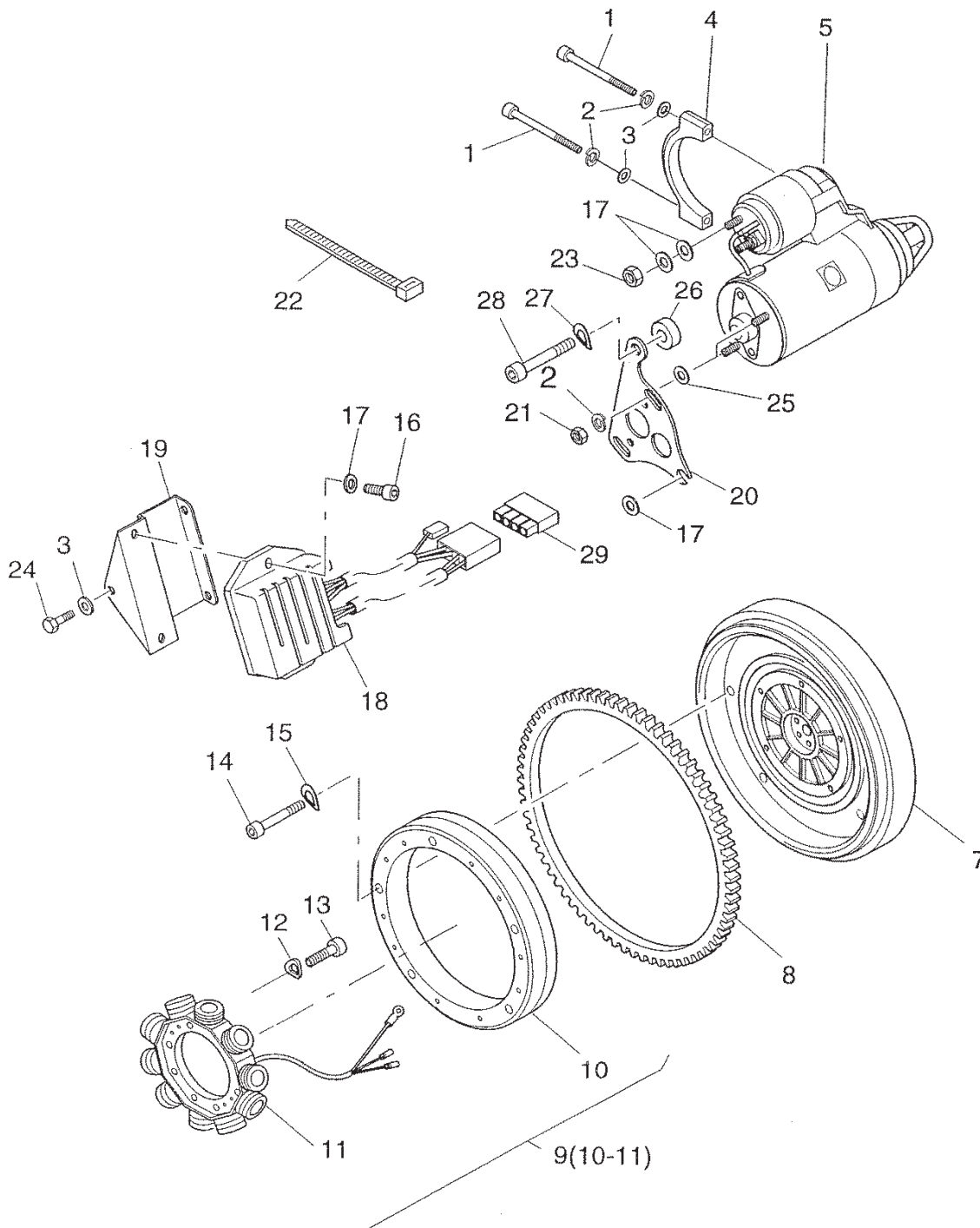



# HATZ 1B40U-2203A — STARTER, ALTERNATOR ASSY.

STARTER, ALTERNATOR ASSY.

<u>NO.</u>	<u>PART NO.</u>	<u>PART NAME</u>	<u>QTY.</u>	<u>REMARKS</u>
1	50402300	ALLEN SCREW M6X70	2	
2	50170900	SPRING WASHER 6	4	
3	50144500	FLAT WASHER 6.4	3	
4	04099100	RETAINING BRACKET	1	
5	50483500	EL. STARTER 12V 1.0KW	1	
7	04161502	FLYWHEEL	1	
8	04151100	GEAR RING	1	
9	50495100	ALTERNATOR ASSY 12V 200W .....	1	INCLUDES ITEMS W/ #
10#		FLYWHEEL COVER .....	1	NOT SOLD SEPARATELY
11#		ALTERNATOR .....	1	NOT SOLD SEPARATELY
12	50081900	SPRING WASHER A5	4	
13	50547000	ALLEN SCREW M5X25	4	
14	50236600	ALLEN SCREW M6X25	5	
15	50081200	SPRING WASHER A6	5	
16	50165400	ALLEN SCREW M8X16	2	
17	50148100	FLAT WASHER 8.4	6	
18	05100701	TENS. REGULATOR 12V	1	
19	01663000	SUPPORT	1	
20	05182912	SUPPORT	1	
21	50144400	HEXAGON NUT M6	2	
22	50439500	STRAP 2.6X200	3	
23	50344700	HEXAGON NUT M8	1	
24	50025400	HEXSCREW M6X10	1	
25	50120000	DISC A6.4	2	
26	03714100	SPACER BUSH	1	
27	50095100	SPRING WASHER A8	1	
28	50392900	ALLEN SCREW M8X50	1	
29	50402100	PLUG SLEEVE HOUSING	1	

# HATZ 1B40U-2203A — ELECTRIC EQUIPMENT, WIRING ASSY.

ELECTRIC EQUIPMENT, WIRING ASSY.

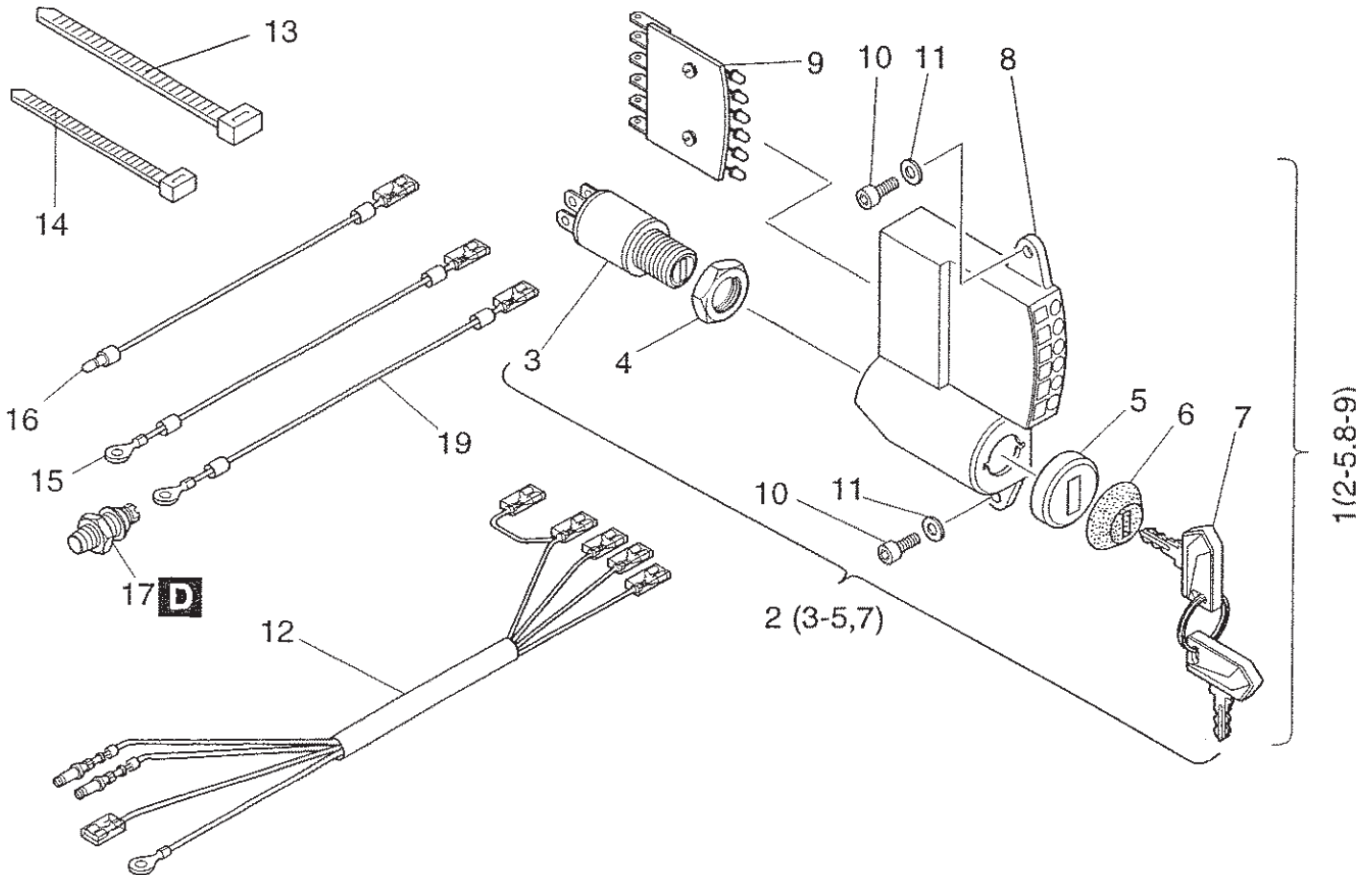

# HATZ 1B40U-2203A — ELECTRIC EQUIPMENT, WIRING ASSY.

## ELECTRIC EQUIPMENT, WIRING ASSY.

<u>NO.</u>	<u>PART NO.</u>	<u>PART NAME</u>	<u>QTY.</u>	<u>REMARKS</u>
1	01560802	INSTRUMENT BOX .....	1 .....	INCLUDES ITEMS W/ #
1	01796500	INSTRUMENT BOX, AUTOMATIC	1	
2#	50384401	STARTING SWITCH .....	1 .....	INCLUDES ITEMS W/ \$
3#\$		STARTING SWITCH BODY .....	1 .....	NOT SOLD SEPARATELY
4#\$		NUT, STARTING SWITCH .....	1 .....	NOT SOLD SEPARATELY
5#\$		FACE PLATE, STARTING SWITCH .....	1 .....	NOT SOLD SEPARATELY
6	05126402	PROTECTION CAP	1	
7#\$	50404900	KEY, SWITCH BOX	1	
8#		HOUSING, INSTRUMENT BOX .....	1 .....	NOT SOLD SEPARATELY
9#		LED DISPLAY .....	1 .....	NOT SOLD SEPARATELY
10	50149100	ALLEN SCREW M6 X 12	2	
11	50144500	FLAT WASHER	2	
12	01785900	WIRING HARNESS	1	
13	50167400	STRAP	1	
14	50439500	STRAP 2.6X200	4	
15	01546800	ELECTRIC WIRE	1	
16	01778000	ELECTRIC WIRE	1	
17	50469100	OIL PRESSURE SWITCH	1	
19	01546500	ELECTRIC WIRE	1	

# HATZ 1B40U-2203A — SPEED CONTROL ASSY.

SPEED CONTROL ASSY.

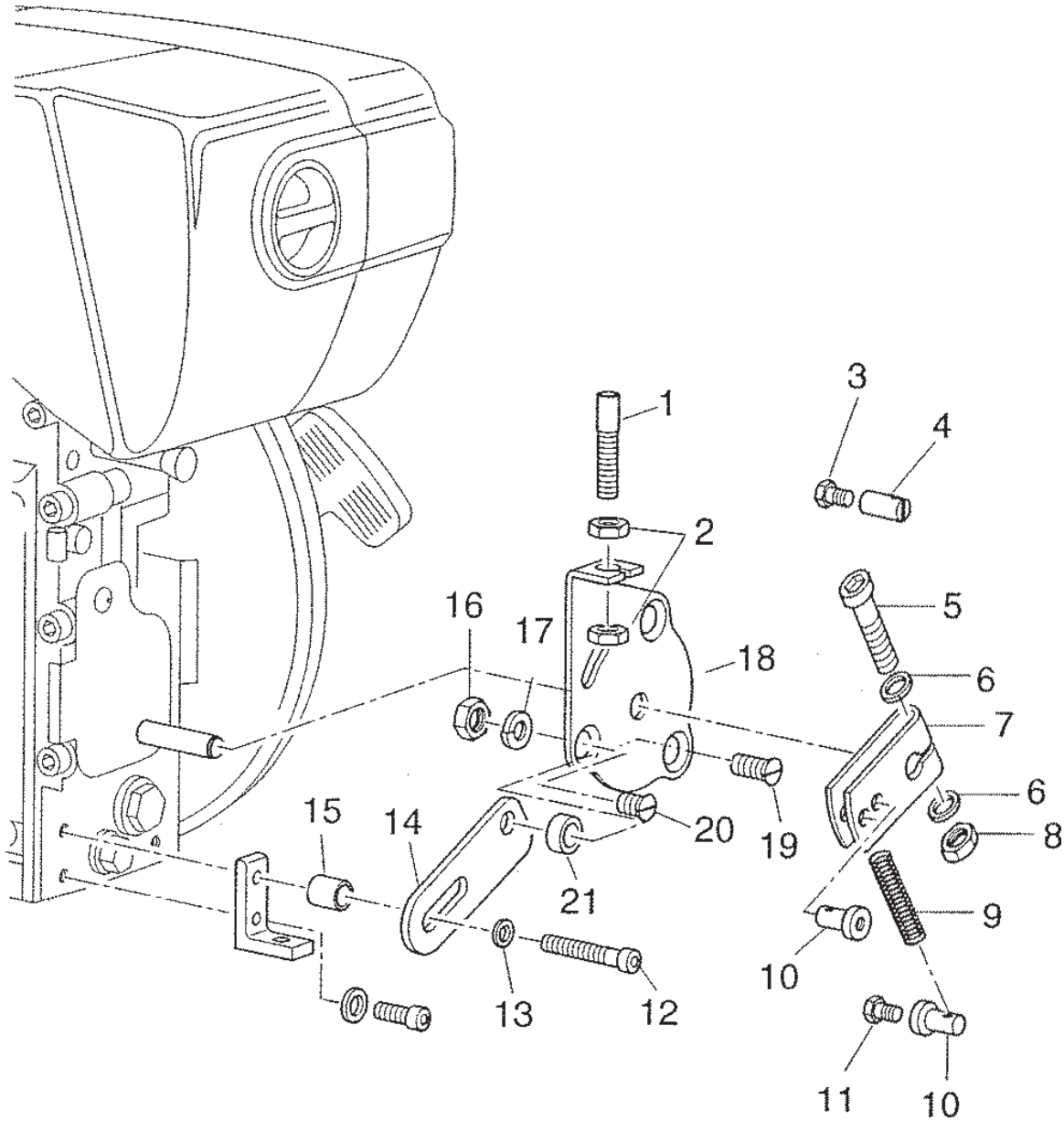

# HATZ 1B40U-2203A — SPEED CONTROL ASSY.

## SPEED CONTROL ASSY.

<u>NO.</u>	<u>PART NO.</u>	<u>PART NAME</u>	<u>QTY.</u>	<u>REMARKS</u>
1	05141200	ADJUSTING SCREW	1	
2	50144400	HEXAGON NUT M6	2	
3	50025000	HEX SCREW M 4X10	1	
4	50483000	CABLE CLAMP	1	
5	50511900	ALLEN SCREW M 5X30	1	
6	50216300	WASHER 5.3	2	
7	05117700	LEVER	1	
8	50094300	HEXAGON NUT M5	1	
9	50484600	PRESSURE SPRING	1	
10	50483100	CABLE CLAMP 2.2MM	2	
11	50025000	HEX SCREW M 4X10	1	
12	50342400	ALLEN SCREW M 8X50	1	
13	50148100	FLAT WASHER 8.4	1	
14	05189600	PLATE	1	
15	03599600	SPACER BUSH	1	
16	50328300	HEXAGON NUT VM6	1	
17	50208500	SPRING WASHER 8	1	
18	05117610	CONSOLE	1	
19	50423900	CTR.SUNK SCREW M6X20	1	
20	50380800	CTR.SUNK SCREW M6X10	1	
21	03292900	SPACER TUBE	1	

# HATZ 1B40U-2203A — ENGINE STOP DEVICE ASSY.

ENGINE STOP DEVICE ASSY.

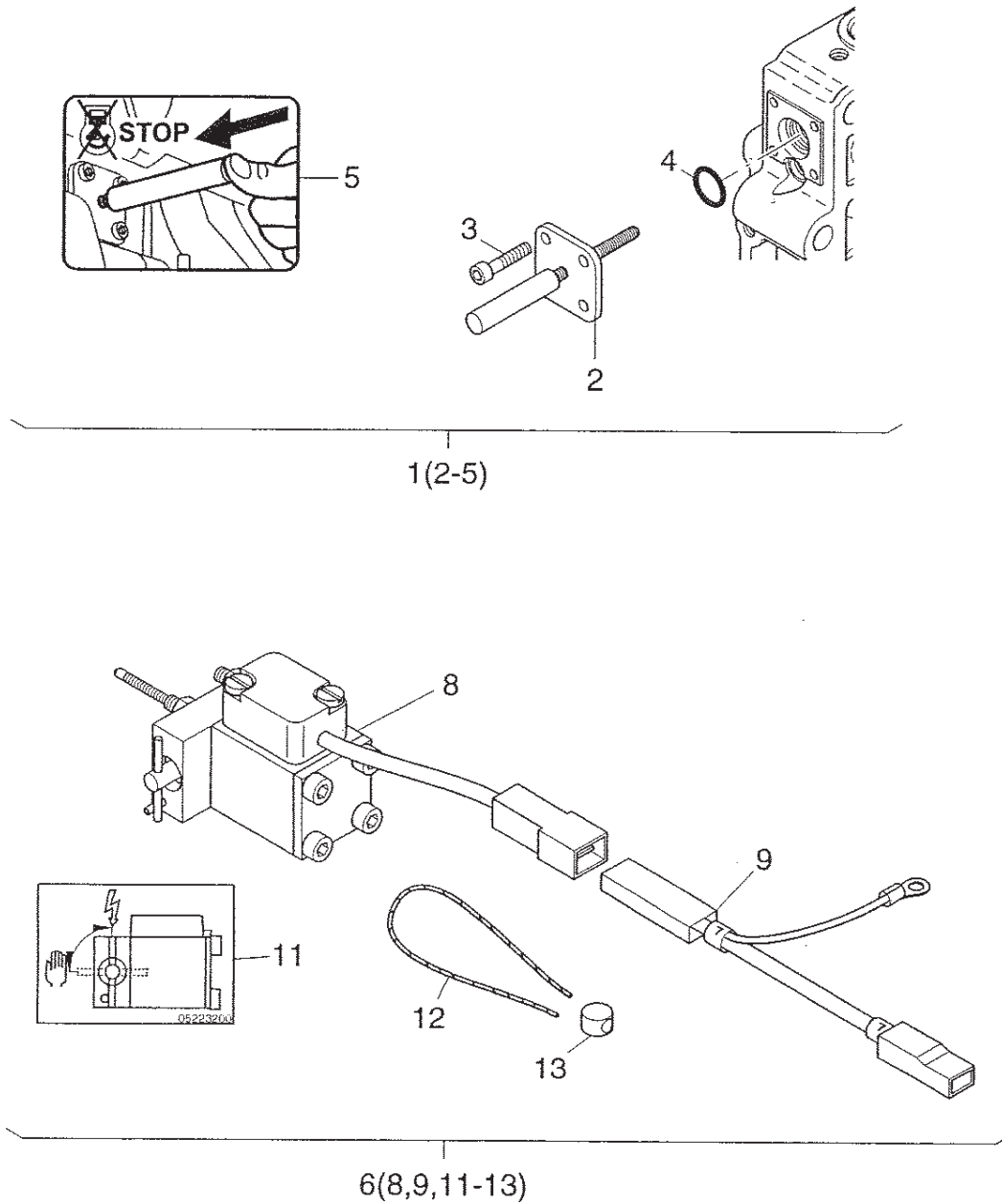

# HATZ 1B40U-2203A — ENGINE STOP DEVICE ASSY.

## ENGINE STOP DEVICE ASSY.

<u>NO.</u>	<u>PART NO.</u>	<u>PART NAME</u>	<u>QTY.</u>	<u>REMARKS</u>
1	01786400	STOP DEVICE ASSY .....	1 .....	INCLUDES ITEMS W/ #
2#		STOP DEVICE .....	1 .....	NOT AVAILABLE SEPARATELY
3#	50446900	ALLEN SCREW, M4 X 16	4	
4#	50329000	O-RING	1	
5#	05221301	STICKER LABEL	1	
6	01786000	LIFT, MGT. EG. STOP ASSY .....	1 .....	INCLUDES ITEMS W/ \$
8\$		LIFT, MGT. EG. STOP .....	1 .....	NOT AVAILABLE SEPARATELY
9\$	01547101	ELECTRICAL WIRE	1	
11\$	05223200	STICKER LABEL	1	
12\$	40021500	SEAL WIRE	1	
13\$	40021400	LEAD SEAL, 8 MM	1	

# HATZ 1B40U-2203A — ENGINE SPECIAL EPA EQUIPMENT

ENGINE SPECIAL EPA EQUIPMENT ASSY.

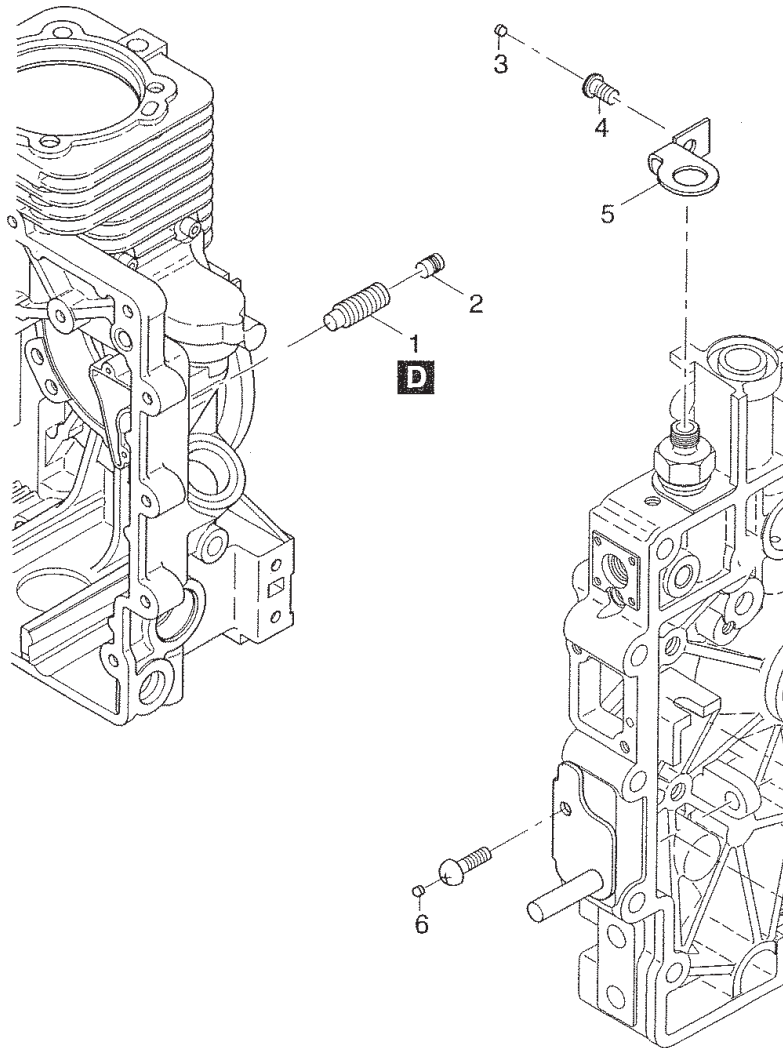



## HATZ 1B40U-2203A — ENGINE SPECIAL EPA EQUIPMENT

ENGINE SPECIAL EPA EQUIPMENT ASSY.

<u>NO.</u>	<u>PART NO.</u>	<u>PART NAME</u>	<u>QTY.</u>	<u>REMARKS</u>
1	04198800	GRUB SCREW	1	
2	04202600	PLUG	1	
3	04170600	PLUG	1	
4	50495000	SCREW M6 X 12	1	
5	04195700	GUARD	1	
6	05201500	CLOSING PLUG	1	

# TERMS AND CONDITIONS OF SALE — PARTS

## PAYMENT TERMS

Terms of payment for parts are net 30 days.

## FREIGHT POLICY

All parts orders will be shipped collect or prepaid with the charges added to the invoice. All shipments are F.O.B. point of origin. Multiquip's responsibility ceases when a signed manifest has been obtained from the carrier, and any claim for shortage or damage must be settled between the consignee and the carrier.

## MINIMUM ORDER

The minimum charge for orders from Multiquip is \$15.00 net. Customers will be asked for instructions regarding handling of orders not meeting this requirement.

## RETURNED GOODS POLICY

Return shipments will be accepted and credit will be allowed, subject to the following provisions:

1. A Returned Material Authorization must be approved by Multiquip prior to shipment.
2. To obtain a Return Material Authorization, a list must be provided to Multiquip Parts Sales that defines item numbers, quantities, and descriptions of the items to be returned.
  - a. The parts numbers and descriptions must match the current parts price list.
  - b. The list must be typed or computer generated.
  - c. The list must state the reason(s) for the return.
  - d. The list must reference the sales order(s) or invoice(s) under which the items were originally purchased.
  - e. The list must include the name and phone number of the person requesting the RMA.
3. A copy of the Return Material Authorization must accompany the return shipment.
4. Freight is at the sender's expense. All parts must be returned freight prepaid to Multiquip's designated receiving point.

5. Parts must be in new and resalable condition, in the original Multiquip package (if any), and with Multiquip part numbers clearly marked.
6. The following items are not returnable:
  - a. Obsolete parts. (If an item is in the price book and shows as being replaced by another item, it is obsolete.)
  - b. Any parts with a limited shelf life (such as gaskets, seals, "O" rings, and other rubber parts) that were purchased more than six months prior to the return date.
  - c. Any line item with an extended dealer net price of less than \$5.00.
  - d. Special order items.
  - e. Electrical components.
  - f. Paint, chemicals, and lubricants.
  - g. Decals and paper products.
  - h. Items purchased in kits.
7. The sender will be notified of any material received that is not acceptable.
8. Such material will be held for five working days from notification, pending instructions. If a reply is not received within five days, the material will be returned to the sender at his expense.
9. Credit on returned parts will be issued at dealer net price at time of the original purchase, less a 15% restocking charge.
10. In cases where an item is accepted, for which the original purchase document can not be determined, the price will be based on the list price that was effective twelve months prior to the RMA date.
11. Credit issued will be applied to future purchases only.

## PRICING AND REBATES

Prices are subject to change without prior notice. Price changes are effective on a specific date and all orders received on or after that date will be billed at the revised price. Rebates for price declines and added charges for price increases will not be made for stock on hand at the time of any price change.

Multiquip reserves the right to quote and sell direct to Government agencies, and to Original Equipment Manufacturer accounts who use our products as integral parts of their own products.

## SPECIAL EXPEDITING SERVICE

A \$35.00 surcharge will be added to the invoice for special handling including bus shipments, insured parcel post or in cases where Multiquip must personally deliver the parts to the carrier.

## LIMITATIONS OF SELLER'S LIABILITY

Multiquip shall not be liable hereunder for damages in excess of the purchase price of the item with respect to which damages are claimed, and in no event shall Multiquip be liable for loss of profit or good will or for any other special, consequential or incidental damages.

## LIMITATION OF WARRANTIES

No warranties, express or implied, are made in connection with the sale of parts or trade accessories nor as to any engine not manufactured by Multiquip. Such warranties made in connection with the sale of new, complete units are made exclusively by a statement of warranty packaged with such units, and Multiquip neither assumes nor authorizes any person to assume for it any other obligation or liability whatever in connection with the sale of its products. Apart from such written statement of warranty, there are no warranties, express, implied or statutory, which extend beyond the description of the products on the face hereof.

Effective: February 22, 2006



# OPERATION AND PARTS MANUAL

## HERE'S HOW TO GET HELP

PLEASE HAVE THE MODEL AND SERIAL  
NUMBER *ON-HAND* WHEN CALLING

### UNITED STATES

#### ***Multiquip Corporate Office***

18910 Wilmington Ave. Tel. (800) 421-1244  
Carson, CA 90746 Fax (800) 537-3927  
Contact: mq@multiquip.com

#### ***Mayco Parts***

800-306-2926 Fax: 800-672-7877  
310-537-3700 Fax: 310-637-3284

#### ***Service Department***

800-421-1244 Fax: 310-537-4259  
310-537-3700

#### ***MQ Parts Department***

800-427-1244 Fax: 800-672-7877  
310-537-3700 Fax: 310-637-3284

#### ***Warranty Department***

800-421-1244, Ext. 279 Fax: 310-537-1173  
310-537-3700, Ext. 279

#### ***Technical Assistance***

800-478-1244 Fax: 310-631-5032

### MEXICO

#### ***MQ Cipsa***

Carr. Fed. Mexico-Puebla KM 126.5 Tel: (52) 222-225-9900  
Momoxpan, Cholula, Puebla 72760 Mexico Fax: (52) 222-285-0420  
Contact: pmastretta@cipsa.com.mx

### CANADA

#### ***Multiquip***

4110 Industriel Boul. Tel: (450) 625-2244  
Laval, Quebec, Canada H7L 6V3 Fax: (450) 625-8664  
Contact: jmartin@multiquip.com

### UNITED KINGDOM

#### ***Multiquip (UK) Limited Head Office***

Hanover Mill, Fitzroy Street, Tel: 0161 339 2223  
Ashton-under-Lyne, Fax: 0161 339 3226  
Lancashire OL7 0TL  
Contact: sales@multiquip.co.uk

### BRAZIL

#### ***Multiquip***

Av. Evandro Lins e Silva, 840 - grupo 505 Tel: 011-55-21-3433-9055  
Barra de Tijuca - Rio de Janeiro Fax: 011-55-21-3433-9055  
Contact: cnavarro@multiquip.com.br, srentes@multiquip.com.br

© COPYRIGHT 2008, MULTIQIP INC.

Multiquip Inc., Mikasa, and the MQ logo are registered trademarks of Multiquip Inc. and may not be used, reproduced, or altered without written permission. All other trademarks are the property of their respective owners and used with permission.

This manual **MUST** accompany the equipment at all times. This manual is considered a permanent part of the equipment and should remain with the unit if resold.

The information and specifications included in this publication were in effect at the time of approval for printing. Illustrations, descriptions, references and technical data contained in this manual are for guidance only and may not be considered as binding. Multiquip Inc. reserves the right to discontinue or change specifications, design or the information published in this publication at any time without notice and without incurring any obligations.

Your Local Dealer is:



## Free Manuals Download Website

<http://myh66.com>

<http://usermanuals.us>

<http://www.somanuals.com>

<http://www.4manuals.cc>

<http://www.manual-lib.com>

<http://www.404manual.com>

<http://www.luxmanual.com>

<http://aubethermostatmanual.com>

Golf course search by state

<http://golfingnear.com>

Email search by domain

<http://emailbydomain.com>

Auto manuals search

<http://auto.somanuals.com>

TV manuals search

<http://tv.somanuals.com>