

# OPERATION AND PARTS MANUAL



*Mikasa* SERIES  
**MODEL MVC98D2**  
**ONE-WAY PLATE COMPACTOR**  
**(YANMAR L48V6 DIESEL ENGINE)**

Revision #1 (01/12/11)

To find the latest revision of this  
publication, visit our website at:  
[www.multiquip.com](http://www.multiquip.com)



**THIS MANUAL MUST ACCOMPANY THE EQUIPMENT AT ALL TIMES.**



### **CALIFORNIA — Proposition 65 Warning**

Engine exhaust and some of its constituents are known to the State of California to cause cancer, birth defects and other reproductive harm.



# TABLE OF CONTENTS

## MQ MIKASA SERIES MVC98D2 PLATE COMPACTOR

Proposition 65 Warning .....	2
Table Of Contents .....	4
Parts Ordering Procedures .....	5
Safety Information .....	6-10
Dimensions .....	11
Specifications .....	12
General Information .....	13
Plate Compactor Components .....	14
Engine Components .....	15
Setup .....	16
Inspection .....	17-18
Operation .....	19-20
Preparation For Long term Storage .....	20
Maintenance .....	21-23
Troubleshooting .....	24-25
Explanation Of Code In Remarks Column .....	26
Suggested Spare Parts .....	27

## COMPONENT DRAWINGS

Decal Placement .....	28-29
Body Assembly .....	30-33
Vibration Assembly .....	34-35
Water Tank Assembly .....	36-37
Transport Wheel Assembly .....	38-39

## YANMAR L48V6F3R4AAW4 ENGINE

Cylinder Block Assembly .....	40-41
Cylinder Head Assembly .....	42-43
Air Cleaner Assembly .....	44-45
Muffler Assembly .....	46-47
Crankshaft and Camshaft Assembly .....	48-49
Piston Assembly .....	50-51
Lub. Oil Pump and Governor Assembly .....	52-53
Cooling and Starting Device Assembly .....	54-55
Fuel Injection Pump Assembly .....	56-57
Fuel Tank and Fuel Line Assembly .....	58-59
Tools, Labels and Gasket Set Assembly .....	60-61

Terms and Conditions Of Sale — Parts .....	62
--	----

### NOTICE

*Specification and part number are subject to change without notice.*

# PARTS ORDERING PROCEDURES

## Ordering parts has never been easier! Choose from three easy options:

Effective:  
January 1<sup>st</sup>, 2006



### Order via Internet (Dealers Only):

Order parts on-line using Multiquip's SmartEquip website!

- View Parts Diagrams
- Order Parts
- Print Specification Information



If you have an MQ Account, to obtain a Username and Password, E-mail us at: **parts@multiquip.com**.

To obtain an MQ Account, contact your District Sales Manager for more information.

Goto [www.multiquip.com](http://www.multiquip.com) and click on **Order Parts** to log in and save!

Use the **internet** and qualify for a **5% Discount** on **Standard orders** for all orders which include complete part numbers.\*

Note: Discounts Are Subject To Change

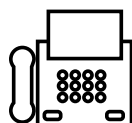

### Order via Fax (Dealers Only):

All customers are welcome to order parts via Fax.

**Domestic (US) Customers dial:**  
1-800-6-PARTS-7 (800-672-7877)

**Fax** your order in and qualify for a **2% Discount** on **Standard orders** for all orders which include complete part numbers.\*

Note: Discounts Are Subject To Change



**Order via Phone: Domestic (US) Dealers Call:**  
1-800-427-1244

### Non-Dealer Customers:

Contact your local Multiquip Dealer for parts or call 800-427-1244 for help in locating a dealer near you.



**International Customers** should contact their local Multiquip Representatives for Parts Ordering information.

## When ordering parts, please supply:

- |   |  |
|---|--|
| <input type="checkbox"/> Dealer Account Number                                | <input type="checkbox"/> Specify Preferred Method of Shipment:                         |
| <input type="checkbox"/> Dealer Name and Address                              | <input checked="" type="checkbox"/> UPS/Fed Ex <input checked="" type="checkbox"/> DHL |
| <input type="checkbox"/> Shipping Address (if different than billing address) | <input type="checkbox"/> Priority One <input checked="" type="checkbox"/> Truck        |
| <input type="checkbox"/> Return Fax Number                                    | <input type="checkbox"/> Ground  |
| <input type="checkbox"/> Applicable Model Number                              | <input type="checkbox"/> Next Day  |
| <input type="checkbox"/> Quantity, Part Number and Description of Each Part   | <input type="checkbox"/> Second/Third Day  |

### NOTICE

All orders are treated as *Standard Orders* and will ship the same day if received prior to 3PM PST.

WE ACCEPT ALL MAJOR CREDIT CARDS!



www.multiquip.com



# SAFETY INFORMATION

Do not operate or service the equipment before reading the entire manual. Safety precautions should be followed at all times when operating this equipment. Failure to read and understand the safety messages and operating instructions could result in injury to yourself and others.



## SAFETY MESSAGES

The four safety messages shown below will inform you about potential hazards that could injure you or others. The safety messages specifically address the level of exposure to the operator and are preceded by one of four words: **DANGER**, **WARNING**, **CAUTION** or **NOTICE**.

## SAFETY SYMBOLS

**DANGER**

Indicates a hazardous situation which, if not avoided, **WILL** result in **DEATH** or **SERIOUS INJURY**.

**WARNING**

Indicates a hazardous situation which, if not avoided, **COULD** result in **DEATH** or **SERIOUS INJURY**.







**CAUTION**

Indicates a hazardous situation which, if not avoided, **COULD** result in **MINOR** or **MODERATE INJURY**.

**NOTICE**

Addresses practices not related to personal injury.

Potential hazards associated with the operation of this equipment will be referenced with hazard symbols which may appear throughout this manual in conjunction with safety messages.

Symbol	Safety Hazard
	Lethal exhaust gas hazards
	Explosive fuel hazards
	Burn hazards
	Respiratory hazards
	Accidental starting hazards
	Eye and hearing hazards
	Rotating parts hazards

# SAFETY INFORMATION

## GENERAL SAFETY

### ⚠ CAUTION

- **NEVER** operate this equipment without proper protective clothing, shatterproof glasses, respiratory protection, hearing protection, steel-toed boots and other protective devices required by the job or city and state regulations.



- **NEVER** operate this equipment when not feeling well due to fatigue, illness or when under medication.



- **NEVER** operate this equipment under the influence of drugs or alcohol.



- **ALWAYS** check the equipment for loosened threads or bolts before starting.
- **DO NOT** use the equipment for any purpose other than its intended purposes or applications.
- **ALWAYS** clear the work area of any debris, tools, etc. that would constitute a hazard while the equipment is in operation.

### NOTICE

- This equipment should only be operated by trained and qualified personnel 18 years of age and older.
- Whenever necessary, replace nameplate, operation and safety decals when they become difficult read.
- Manufacturer does not assume responsibility for any accident due to equipment modifications. Unauthorized equipment modification will void all warranties.
- **NEVER** use accessories or attachments that are not recommended by Multiquip for this equipment. Damage to the equipment and/or injury to user may result.
- **ALWAYS** know the location of the nearest **fire extinguisher**.
- **ALWAYS** know the location of the nearest **first aid kit**.
- **ALWAYS** know the location of the nearest phone or **keep a phone on the job site**. Also, know the phone numbers of the nearest **ambulance, doctor and fire department**. This information will be invaluable in the case of an emergency.

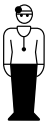

# SAFETY INFORMATION

## COMPACTOR SAFETY

### DANGER

- **NEVER** operate the equipment in an explosive atmosphere or near combustible materials. An explosion or fire could result causing severe bodily harm or even death.



### WARNING

- **NEVER** disconnect any **emergency or safety devices**. These devices are intended for operator safety. Disconnection of these devices can cause severe injury, bodily harm or even death. Disconnection of any of these devices will void all warranties.

### CAUTION

- **NEVER** lubricate components or attempt service on a running machine.

### NOTICE

- **ALWAYS** keep the machine in proper running condition.
- Fix damage to machine and replace any broken parts immediately.
- **ALWAYS** store equipment properly when it is not being used. Equipment should be stored in a clean, dry location out of the reach of children and unauthorized personnel.

## ENGINE SAFETY

### DANGER

- The engine fuel exhaust gases contain poisonous carbon monoxide. This gas is colorless and odorless, and can cause death if inhaled.
- The engine of this equipment requires an adequate free flow of cooling air. **NEVER** operate this equipment in any enclosed or narrow area where free flow of the air is restricted. If the air flow is restricted it will cause injury to people and property and serious damage to the equipment or engine.



### WARNING

- **DO NOT** place hands or fingers inside engine compartment when engine is running.
- **NEVER** operate the engine with heat shields or guards removed.
- Keep fingers, hands hair and clothing away from all moving parts to prevent injury.
- **DO NOT** remove the radiator cap while the engine is hot. High pressure boiling water will gush out of the radiator and severely scald any persons in the general area of the compactor.
- **DO NOT** remove the coolant drain plug while the engine is hot. Hot coolant will gush out of the coolant tank and severely scald any persons in the general area of the compactor.
- **DO NOT** remove the engine oil drain plug while the engine is hot. Hot oil will gush out of the oil tank and severely scald any persons in the general area of the compactor.



### CAUTION

- **NEVER** touch the hot exhaust manifold, muffler or cylinder. Allow these parts to cool before servicing equipment.



### NOTICE

- **NEVER** run engine without an air filter or with a dirty air filter. Severe engine damage may occur. Service air filter frequently to prevent engine malfunction.
- **NEVER** tamper with the factory settings of the engine or engine governor. Damage to the engine or equipment can result if operating in speed ranges above the maximum allowable.
- **NEVER** tip the engine to extreme angles during lifting as it may cause oil to gravitate into the cylinder head, making the engine start difficult.







# SAFETY INFORMATION

## FUEL SAFETY

### DANGER

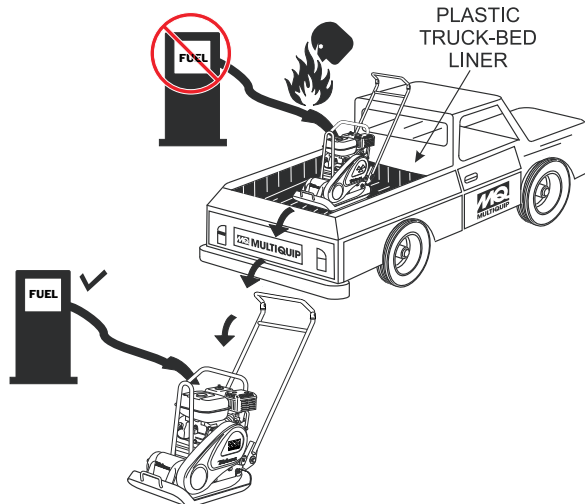
- **DO NOT** add fuel to equipment if it is placed inside truck bed with plastic liner. Possibility exists of explosion or fire due to static electricity.





- **DO NOT** start the engine near spilled fuel or combustible fluids. Diesel fuel is extremely flammable and its vapors can cause an explosion if ignited.
- **ALWAYS** refuel in a well-ventilated area, away from sparks and open flames.
- **ALWAYS** use extreme caution when working with **flammable** liquids.
- **DO NOT** fill the fuel tank while the engine is running or hot.
- **DO NOT** overfill tank, since spilled fuel could ignite if it comes into contact with hot engine parts or sparks from the ignition system.
- Store fuel in appropriate containers, in well-ventilated areas and away from sparks and flames.
- **NEVER** use fuel as a cleaning agent.
- **DO NOT** smoke around or near the equipment. Fire or explosion could result from fuel vapors or if fuel is spilled on a hot engine. 

## BATTERY SAFETY (ELECTRIC START ONLY)

### DANGER

- **DO NOT** drop the battery. There is a possibility that the battery will explode.
- **DO NOT** expose the battery to open flames, sparks, cigarettes, etc. The battery contains combustible gases and liquids. If these gases and liquids come into contact with a flame or spark, an explosion could occur. 

### WARNING

- **ALWAYS** wear safety glasses when handling the battery to avoid eye irritation. The battery contains acids that can cause injury to the eyes and skin. 
- Use well-insulated gloves when picking up the battery.
- **ALWAYS** keep the battery charged. If the battery is not charged, combustible gas will build up.
- **DO NOT** charge battery if frozen. Battery can explode. When frozen, warm the battery to at least 61°F (16°C).
- **ALWAYS** recharge the battery in a well-ventilated environment to avoid the risk of a dangerous concentration of combustible gases.
- If the battery liquid (dilute sulfuric acid) comes into contact with **clothing or skin**, rinse skin or clothing immediately with plenty of water. 
- If the battery liquid (dilute sulfuric acid) comes into contact with **eyes**, rinse eyes immediately with plenty of water and contact the nearest doctor or hospital to seek medical attention.

### CAUTION

- **ALWAYS** disconnect the **NEGATIVE** battery terminal before performing service on the equipment.
- **ALWAYS** keep battery cables in good working condition. Repair or replace all worn cables.

## TRANSPORTING SAFETY

### CAUTION

- NEVER allow any person or animal to stand underneath the equipment while lifting.

### NOTICE

- Before lifting, make sure that the equipment parts (hook and vibration insulator) are not damaged and screws are not loose or missing.
- Always make sure crane or lifting device has been properly secured to the lifting bail (hook) of the equipment.
- **ALWAYS** shutdown engine before transporting.
- **NEVER** lift the equipment while the engine is running.
- Tighten fuel tank cap securely and close fuel cock to prevent fuel from spilling.
- Use adequate lifting cable (wire or rope) of sufficient strength.
- Use one point suspension hook and lift straight upwards.
- **DO NOT** lift machine to unnecessary heights.
- **ALWAYS** tie down equipment during transport by securing the equipment with rope.

## ENVIRONMENTAL SAFETY

### NOTICE

- Dispose of hazardous waste properly. Examples of potentially hazardous waste are used motor oil, fuel and fuel filters. 
- **DO NOT** use food or plastic containers to dispose of hazardous waste.
- **DO NOT** pour waste, oil or fuel directly onto the ground, down a drain or into any water source.

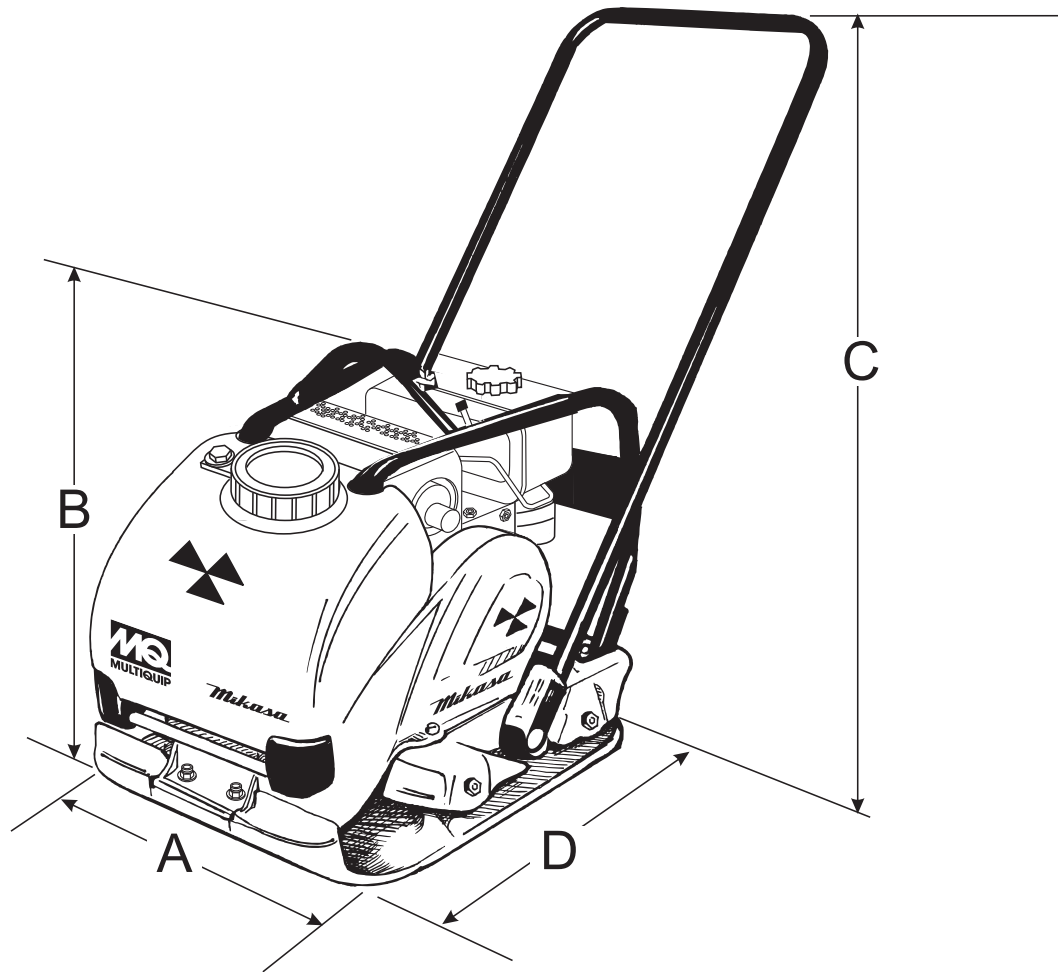

Figure 1. MVC98D2 Reversible Plate Compactor Dimensions

TABLE 1. DIMENSIONS	
REFERENCE LETTER	DIMENSIONS IN. (MM)
A	19.75 in. (502 mm.)
B	26 in. (660 mm.)
C	40 in. (1,016 mm.)
D	22.75 in. (578 mm.)

<b>TABLE 2. Specifications (Compactor)</b>	
Models	MVC-98D2
Centrifugal Force	3,350 lbs. (1,520 kg)
Number of Vibrations	6,000 vibrations/min
Traveling Speed	72 ft./min (22 meters/min)
Plate Size (LxW)	19.6 x 22.0 in. (498 x 559 mm)
Operating Weight	218 lbs. (99 kg)
Water Tank Capacity	13.7 qt. (13.0 liters)
Max. Area Of Compaction	7092 sq. ft./hr.

<b>Table 3. Specifications (Engine)</b>		
<b>Engine</b>	<b>Model</b>	<b>YANMAR L48V6F3R4AAW4</b>
	Type	Air-cooled 4 stroke, Vertical Single Cylinder, Diesel Engine
	Bore X Stroke	2.7 in. x 1.8 in. (70 mm x 57 mm)
	Displacement	219 cc (13.4 cu-in)
	Max Output	4.2 H.P./3600 R.P.M.
	Fuel Tank Capacity	Approx. 0.63 U.S. gallons (2.4 liters)
	Fuel	Diesel Fuel
	Lube Oil Capacity	0.84 qts. (.80 liters)
	Starting Method	Recoil Start
<b>Dimension (L x W x H)</b>		13.1 x 15.1 x 16.5 in. (332.5 x 384.5 x 417.8 mm)
<b>Dry Net Weight</b>		58.4 lbs (26.5 Kg.)

## Plate Compactor

The Mikasa MVC98D2 is a walk-behind plate compactor designed for the compaction of sand, clay and asphalt. This plate compactor is a powerful compacting tool capable of applying a tremendous force in consecutive high frequency vibrations to a soil surface. Its applications include soil compacting for road, embankments and reservoirs as well as backfilling for gas pipelines, water pipelines and cable installation work.

## Compactor Components

This plate compactor is comprised of an anti-vibration handle, vibrating case (eccentric), water tank, guard hook, rubber shock absorbers and a Yanmar diesel engine.

## Vibratory Plates

The vibratory plates of the MVC98D2 produce low amplitude high frequency vibrations, designed to compact granular soils and asphalt.

The resulting vibrations cause forward motion. The engine and handle are vibration isolated from the vibrating plate. The heavier the plate, the more compaction force it generates.

## Power Transfer

The Mikasa MVC98D2 Plate Compactor is equipped with an air-cooled, vertical single-cylinder, 4-stroke Yanmar L48V6 diesel engine. A centrifugal clutch is attached to the output shaft of the engine and will engage when the engine speed reaches approximately 2,300 ~ 2,600 rpm's.

Engine shaft speed is transferred via engine pulley and V-belt to vibrator pulley. The vibrator pulley rotates an eccentric rotor shaft that is contained within the vibrator case.

The generated vibration created from the eccentric rotor is transmitted to the compacting plate. This vibration causes the compactor to move in a forward direction.

## Frequency/Speed

The compactor's vibrating plate maximum frequency is 6,000 vpm (vibrations per minute). The forward and reverse travel speed of the compactor is approximately 72 ft./minute (22 meters/minute).

## Water Sprinkler System

The water sprinkler system will provide about 20 minutes of sprinkling with the water cock in the full open position and the compactor operating at full speed. It is suggested to mix a small amount of detergent or diesel fuel with water. This will allow the water to flow much easier.

## Controls

Before starting the MVC98D2 Plate Compactor, identify and understand the function of the controls and components as indicated in Figure 2.

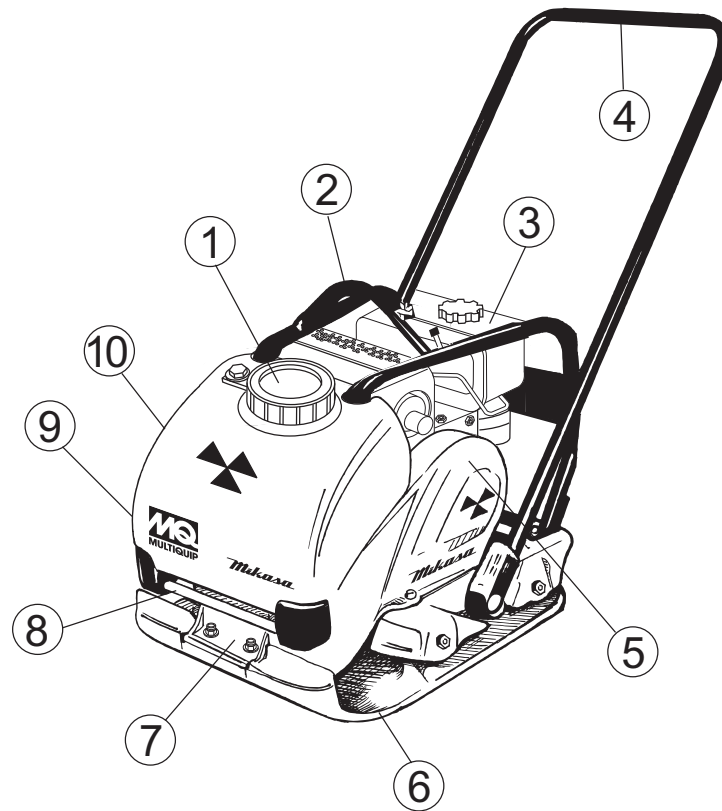
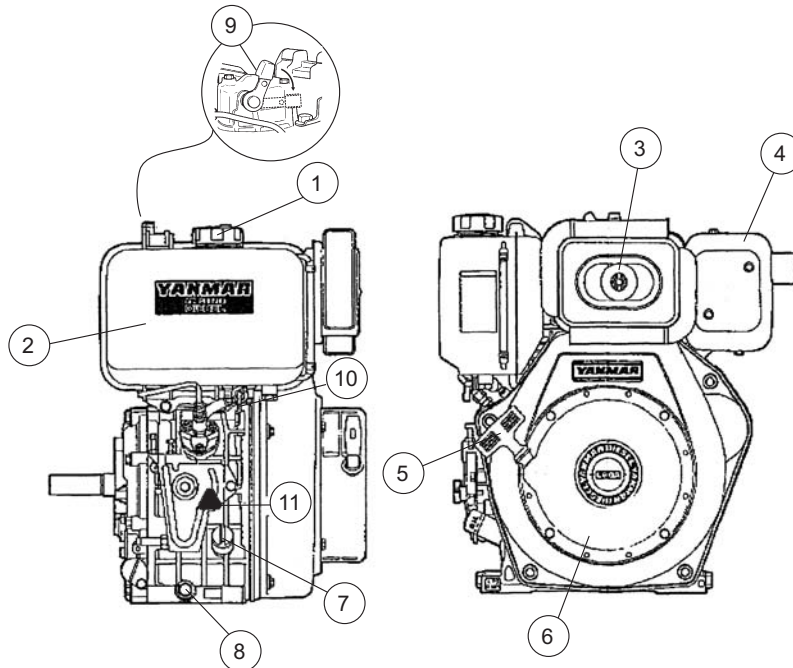

Figure 2. MVC98D2 Components

Figure 2 illustrates the location of the major components for the MVC98D2 Plate Compactor. The function of each component is described below:

1. **Water Tank Cap** – Remove this cap to add water to the water tank.
2. **Lifting Hook** – When lifting of the compactor is required either by forklift, crane etc., tie rope or chain around this lifting point.
3. **Diesel Engine** – This plate compactor uses a YANMAR L48V6 engine. Refer to the YANMAR owners manual for engine information and related topics.
4. **Handle Bar** – When operating the compactor use this handle bar to maneuver the compactor.
5. **Belt Cover** – Remove this cover to gain access to the V-belt. **NEVER** run the compactor without the V-belt cover. If the V-belt cover is not installed, the possibility exist that your hand may get caught between the V-belt and clutch, thus causing serious injury and bodily harm.
6. **Vibrating Plate** – A flat, open plate made of durable cast iron construction used in the compacting of soil.
7. **Vibration Case** – Encloses the eccentric, gears and counter weights.
8. **Water Tube (Sprinkler)** – Supplies water to the soil via a splash plate.
9. **Water Shut-Off Valve** – Turn this valve downward to let water flow from the water tank to the water tube.
10. **Water Tank** – Holds 13.7 quarts of water, removable no tools required.



**Figure 3. Engine Controls and Components**

The engine shown above is a **YANMAR L48V6** engine (Figure 3). The engine must be checked for proper lubrication and filled with fuel prior to operation. Refer to the manufacturer's engine manual for instructions and details of operation and servicing. Each component is described below:

1. **Fuel Filler Cap** – Remove this cap to add unleaded gasoline to the fuel tank. Make sure cap is tightened securely. **DO NOT** over fill.
2. **Fuel Tank** – Capacity is 2.5 quarts (2.4 liters) of diesel fuel.
3. **Air Cleaner** – Prevents dirt and other debris from entering the fuel system. Remove wing-nut on top of air filter canister to gain access to filter element.
4. **Muffler** – Used to reduce noise and emissions.
5. **Recoil Starting Handle (pull rope)** – Type of engine starting method.

7. **Oil Filler Cap / Dipstick** – Remove this cap to add oil to the engine crankcase. Read dipstick to determine if oil level is low. **DO NOT** over fill.

### NOTICE

Operating the engine without an air filter, with a damaged air filter, or a filter in need of replacement will allow dirt to enter the engine, causing rapid engine wear.

8. **Oil Drain Plug** – Unscrew plug to drain oil from engine crankcase. Dispose of oil in a safe manner.
9. **Decompression Lever**– Press down before starting engine. To prevent damage to engine, **DO NOT** use for any other purpose.

### WARNING



Add fuel to the tank only when the engine is stopped and has cooled down. In the event of a fuel spill, **DO NOT** attempt to start the engine until the fuel residue has been completely wiped up and the area surrounding the engine is dry.

### WARNING



Engine components can generate extreme heat. To prevent burns, **DO NOT** touch these areas while the engine is running or immediately after operating. **NEVER** operate the engine with the muffler removed.

6. **Recoil Starter**– Manual-starting method. Pull the starter grip until resistance is felt, then pull briskly and smoothly.

10. **Fuel Cock**– Controls the flow of diesel fuel to the carburetor. Must be in the ON position when starting and running the engine.
11. **Speed Control Lever**– Regulates engine speed.

## Compactor Instructions

The purpose of this section is to assist the user in the setting up of a **NEW** compactor. If your compactor is already assembled (vibration handle), then this section can be skipped.

Before packaging and shipping this MQ Mikasa Walk-Behind Plate compactor was run and tested at the factory. If there are problems, please let us know.

### NOTICE

The new plate compactor cannot be put into service until the setup installation instructions are completed. These setup instructions only need to be performed at the time of unpacking a **NEW** compactor.

## Steering Handle Assembly

The steering handle is not attached to the compactor's lower base at the time of shipment. To attach the steering handle to the lower base assembly perform the following:

1. Remove the bolts and washers (handle mounting hardware) from both sides of the plate compactor (Figure 4).
2. Position the anti-vibration handle over the compactor.
3. Align the holes at the bottom of the handle to the holes on the compactor (lower base) where the bolts and washers were removed. Install and tighten the bolts and washers.

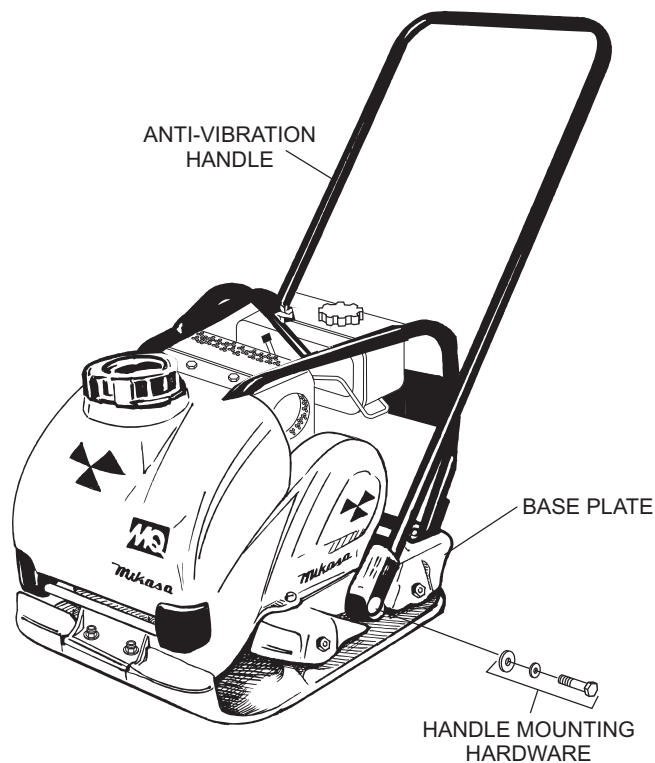



Figure 4. Installing the Steering Handle



**CAUTION**



**NEVER** operate the unit in a confined area or enclosed area structure that does not provide ample **free flow of air**.

**CAUTION**



**ALWAYS** wear approved eye and hearing protection before operating the unit.

### Before Starting:

1. Read safety instructions at the beginning of manual.
2. Remove dirt and dust, particularly in the engine cooling air inlet, carburetor and air cleaner.
3. Check the air filter for dirt and dust. If air filter is dirty, replace air filter with a new one as required.
4. Check carburetor for external dirt and dust. Clean with dry compressed air.
5. Check fastening nuts and bolts for tightness.



### Engine Oil Check:

1. To check the engine oil level, place the compactor on secure level ground with the engine stopped.
2. Remove the filler dipstick from the engine oil filler hole (Figure 5) and wipe clean.

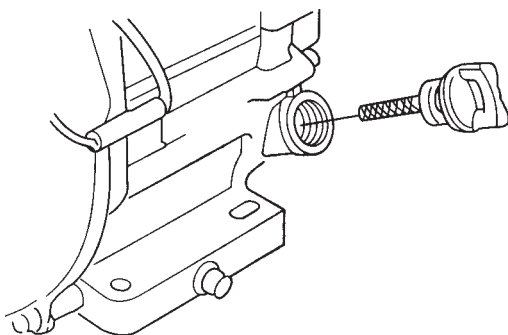

Figure 5. Engine Oil Dipstick (Removal)

3. Insert and remove the dipstick without screwing it into the filler neck. Check the oil level shown on the dipstick.
4. If the oil level is low (Figure 6), fill to the edge of the oil filler hole with the recommended oil type (Table 4). Maximum oil capacity is 0.84 quarts (0.80 liters).

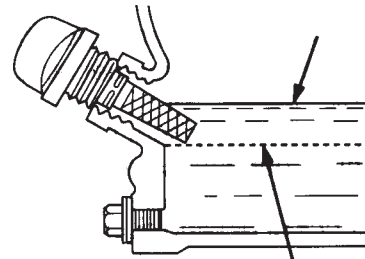
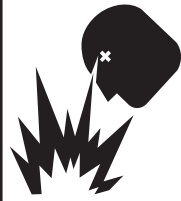

Figure 6. Engine Oil Dipstick (Oil Level)

Table 4. Oil Type

Season	Temperature	Oil Type
Summer	25°C or Higher	SAE 10W-30
Spring/Fall	25°C~10°C	SAE 10W-30/20
Winter	0°C or Lower	SAE 10W-10

**DANGER**



**EXPLOSIVE FUEL!**  
Motor fuels are highly flammable and can be dangerous if mishandled. **DO NOT** smoke while refueling. **DO NOT** attempt to refuel if the engine is **hot** or **running**.

### Fuel Check:

1. Remove the fuel cap located on top of fuel tank.
2. Visually inspect to see if the fuel level is low. If fuel is low, replenish with clean diesel fuel.
3. When refueling, be sure to use a strainer for filtration. **DO NOT** top-off fuel. Wipe up any spilled fuel **immediately!**

## V-Belt Check

### CAUTION

**NEVER** attempt to check the V-belt with the engine running. Severe injury can occur if your hand (Figure 7) gets caught between the V-belt and the clutch. Always use safety gloves.

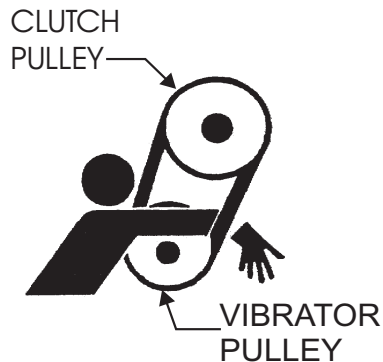

**Figure 7. V-Belt Hazard**

1. To check the V-belt tension, remove the three bolts that secure the belt cover to the frame as shown in Figure 8.

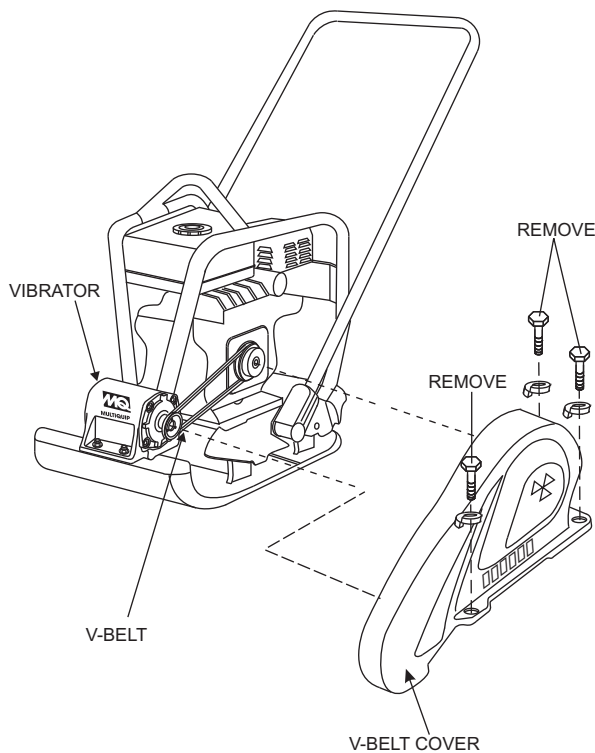

**Figure 8. V-Belt Cover Removal**

2. The V-belt tension is proper if the V-belt bends 10 to 15 mm (Figure 9) when depressed with finger at midway between the clutch and vibration pulley shafts.

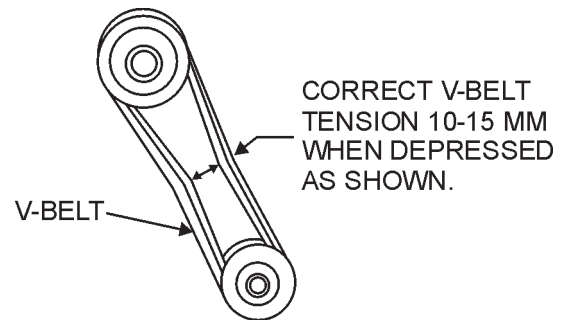
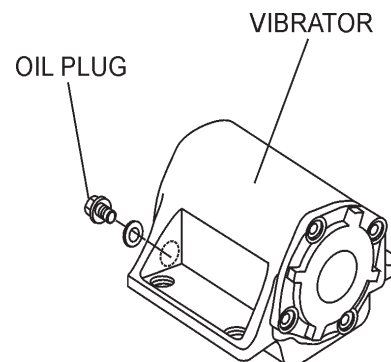

**Figure 9. V-Belt Tension**

3. A loose V-belt will decrease the power transmission output, causing reduced compaction and premature wear of the belt.
4. If the V-belt becomes worn or loose, replace it. See maintenance section.

## Vibrator Oil Check

1. Place the MVC98D2 plate compactor horizontally on a flat surface. Make sure the compactor is level when checking the oil in the vibrator assembly.
2. Check vibrator oil level by removing the plug (vibrator oil gauge) as shown in Figure 10. The oil level should be up to the oil plug. The vibrator holds 140 cc (approximately 4 oz.). **IMPORTANT**, if oil is required, replace using only SAE10W-30 motor oil.



**Figure 10. Vibrator Oil Plug**

This section is intended to assist the operator with the **initial start-up** of the compactor. It is extremely important that this section be read carefully before attempting to use the compactor in the field.

## Starting the Engine

1. Open the fuel cock (Figure 11).

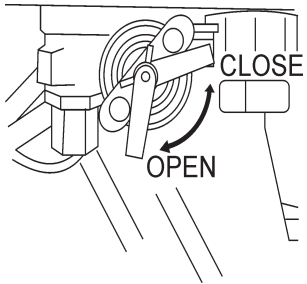

Figure 11. Fuel Cock

2. Move the engine speed control lever (Figure 12) to the **IDLE** position.

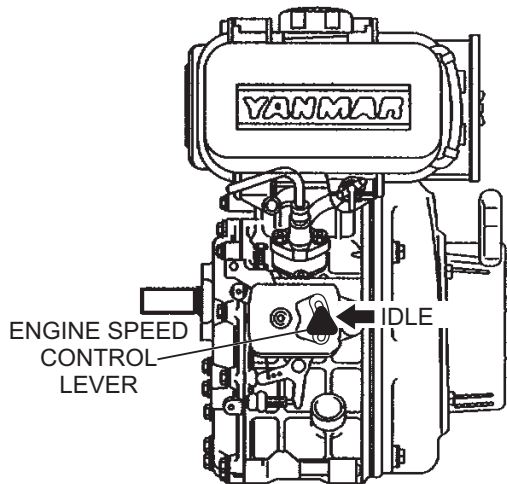

Figure 12. Engine Speed Control Lever (Idle Position)

3. Push down the decompression lever (Figure 13) and release.

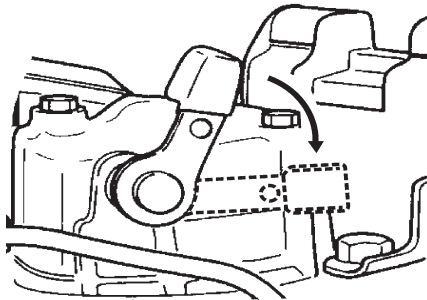

Figure 13. Decompression Lever

4. Grasp the starter grip (Figure 14) and slowly pull it out. The resistance becomes the hardest at a certain position, corresponding to the compression point. Pull the starter grip briskly and smoothly for starting.

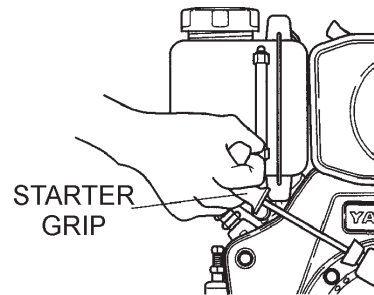

Figure 14. Starter Grip

5. If the engine does not start, repeat steps 1 thru 4.

## Operation

1. Once the engine has started, move the engine speed lever quickly to the **FAST** (Figure 15) position.
2. With the engine speed control lever placed in the **FAST** position, the engine speed should be between 2,300 ~2,600 RPM's, therefore engaging the centrifugal clutch.

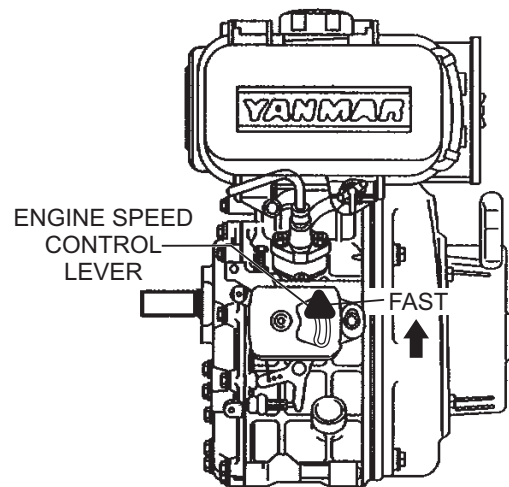

Figure 15. Speed Control Lever (Fast Position)

### NOTICE

**ALWAYS** move the throttle lever quickly without hesitation, because increasing the engine speed slowly causes the clutch to slip.

# OPERATION/PREPARATION FOR LONG-TERM STORAGE

## CAUTION

Make sure to follow all safety rules referenced in the safety information section of this manual before operating compactor. Keep work area clear of debris and other objects that could cause damage to the compactor or bodily injury.

3. Firmly grasp the compactor's handle bar with both hands, the compactor will begin moving forward.
4. Slowly walk behind the compactor and be on the lookout for any large objects or foreign matter that might cause damage to the compactor or bodily injury.
5. Compactor traveling speed may drop on soils which contain clay, however there may be cases where traveling speed drops because the compaction plate does not leave the ground surface easily due to the composition of the soil. To rectify this problem do the following:
  - Check the bottom plate to see if clay or equivalent material has been lodged in the plate mechanism. If so, wash with water and remove.
  - Remember the compactor does not work as efficiently on clay or soils that have a high moisture content level.
  - If the soil has a high moisture level, dry soil to appropriate moisture content level or carry out compaction twice.

## NOTICE

Whenever the compactor's vibration becomes weak or lost during normal operation, regardless of operation hours, check the V-belt and clutch immediately.

## Normal Shut-Down Procedure:

1. Place the speed control lever in the **IDLE** position. Allow the engine to cool down for 2 to 3 minutes.
2. Next, place the speed control lever in the **STOP** position (Figure 16) to stop the engine.
3. Close the fuel cock (Figure 11).

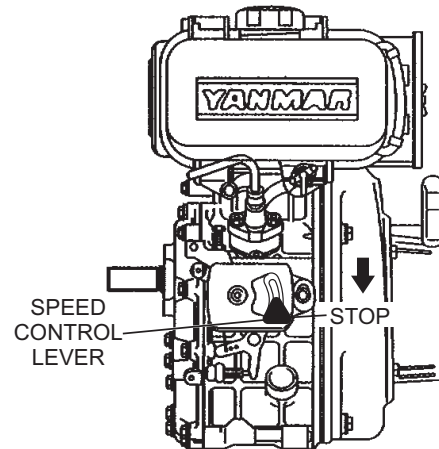

Figure 16. Speed Control Lever (Stop Position)

## Emergency Shutdown Procedure:

1. Move the speed control lever quickly to the **STOP** position (Figure 16).
2. Close the fuel cock.

## Compactor Storage

For storage of the compactor for over 30 days, the following is required:

- Drain the fuel tank completely, or add STA-BIL to the fuel.
- Run the engine until the fuel in the injection system is completely consumed.
- Completely drain the oil from the crankcase and refill with fresh oil.
- Pour 2 or 3 cc of SAE 30 oil into the cylinder and crank slowly to distribute the oil.
- Pull out the starter rope slowly and stop at the compression point.
- Clean all external parts of the compactor with a cloth.
- Cover the compactor and store in a clean, dry place.

## CAUTION

Inspection and other services should **always** be carried out on hard and level ground with the engine shutdown.

### Inspection and Maintenance Service Tables.

To make sure your plate compactor is always in good working condition before using, carry out the maintenance inspection in accordance with Tables 5 through 7.

**TABLE 5. MVC-98D2 MACHINE INSPECTION**

ITEM	HOURS OF OPERATION
Loose or Missing Screws	Every 8 hours (every day)
Damaged Parts	Every 8 hours (every day)
V-Belt Check/Replacement	Every 200 hours
Clutch Check	Every 200 hours
Vibrator Oil Check	Every 100 hours
Vibrator Oil Replacement	Every 300 hours
Clutch Check	Every 200 hours

## NOTICE

These inspection intervals are for operation under normal conditions. Adjust your inspection intervals based on the number hours plate compactor is in use, and particular working conditions. Fuel piping and connections should be replaced every 2 years.

**TABLE 6. MVC-98D2 ENGINE CHECK**

ITEM	HOURS OF OPERATION
Oil or Fuel Leak	Every 8 hours (every day)
Tightness of Fastening Threads	Every 8 hours (every day)
Engine Oil Check and Replenishment	Every 8 hours (every day) (Replenish to specified maximum level)
Engine Oil Replacement	After first 25 hours then every 50 to 100 hours
Air Filter Cleaning	Every 100 hours
See separate engine manual for details on engine maintenance.	

### Daily Service

- Check for leakage of fuel or oil.
- Check for loose screws including tightness. See Table 7 below (tightening torque), for retightening:

**TABLE 7. TIGHTENING TORQUE (in. kg/cm) Diameter**

Material	6mm	8mm	10mm	12mm	14mm	16mm	18mm	20mm
4T	70	150	300	500	750	1,100	1,400	2,000
6-8T	100	250	500	800	1,300	2,000	2,700	3,800
11T	150	400	800	1,200	2,000	2,900	4,200	5,600
*	100	300~350	650~700					

\* (In case counter-part is of aluminum)  
(Threads in use with this machine are all right handed)  
Material and quality of material is marked on each bolt, and screw.

- Remove soil and clean the bottom of compaction plate.
- Check vibrating case for any oil leakage.
- Check engine oil.

## Engine Oil Replacement

1. Replace engine oil, first in 25 hours of operation and every 50 to 100 hours afterwards.
2. Drain the engine oil when the oil is **warm** as shown in Figure 17.

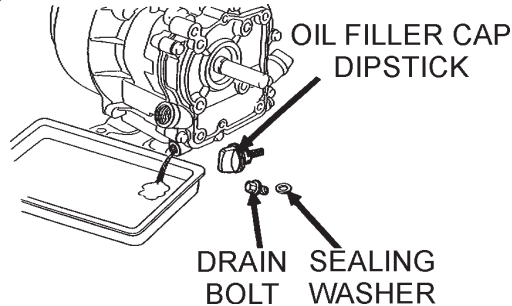

**Figure 17. Engine Oil (Draining)**

3. Remove the oil drain bolt and sealing washer and allow the oil to drain into a suitable container.
4. Replace engine oil in the oil tank with recommended type oil as listed in Table 4. Engine oil capacity is 1.16 quarts (1.1 liter). **DO NOT** overfill.
5. Install drain bolt with sealing washer and tighten securely.

## Air Filter Cleaning

1. Remove the air cleaner cover and foam filter element as shown in Figure 18.
2. Tap the paperfilter element (Figure 18) several times on a hard surface to remove dirt, or blow compressed air [not exceeding 30psi (207 kPa, 2.1 kgf/cm<sup>2</sup>)] through the filter element from the air cleaner case side.

### **CAUTION**

**NEVER** brush off dirt. Brushing will force dirt into the fibers and cause poor performance in your air filter. Replace the paper filter element if it is excessively dirty.

3. Clean foam element in warm, soapy water or nonflammable solvent. Rinse and dry thoroughly. Dip the element in clean engine oil and completely squeeze out the excess oil from the element before installing.

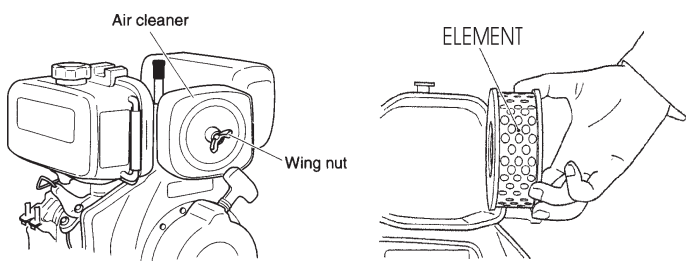
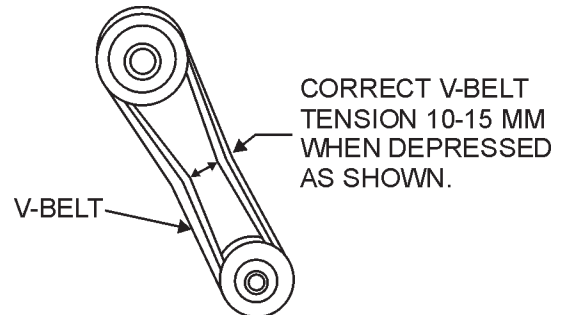

**Figure 18. Engine Air Filter**

## Checking and the V-Belt

After 200 hours of operation, remove the belt cover to check the V-belt tension (Figure 19).

1. Remove the belt cover.
2. Tension is proper if the belt bends about 10 mm when depressed strongly with finger between shafts. Loose or worn V-belts reduces power transmission efficiency, causing weak compaction and reduces the life of the belt itself.



**Figure 19. Checking V-belt Tension**

### **CAUTION**



**NEVER** attempt to check the V-belt with the engine running. Severe injury can occur if your hand gets caught between the V-belt and the clutch. Always use safety gloves.

## Replacing the V-belt

1. Remove the V-belt cover (Figure 20).
2. Using cutters, simply cut the worn or defective V-belt and discard.
3. Place one end of the new V-belt onto the upper pulley (clutch side).
4. Place a 19 mm offset wrench or the like onto the lower vibrator pulley fastening bolt.
5. Place the other end of the V-belt onto lower vibrator pulley. Rotate offset wrench clockwise so that the V-belt moves onto the lower vibrator pulley.

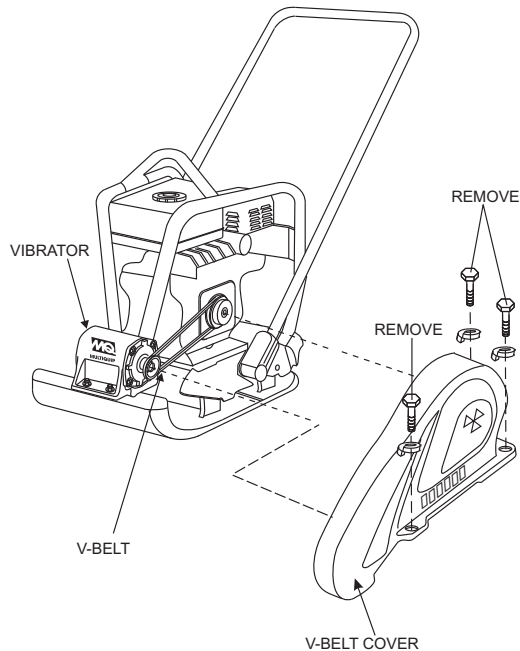

**Figure 20. V-Belt Check**

## Vibrating Case Oil Replacement (300 Hours)

### **CAUTION**

Always clean the area around the vibrator oil plug (oil level check) hole before removing plug. This will prevent dirt and debris from entering the system.

1. Place the plate compactor horizontally on a flat surface.
2. Remove oil drain plug (Figure 21) from vibrator and drain oil from the vibrating case.
3. Using a funnel, fill vibrating case with SAE10W-30 motor oil. The oil level should be up to the oil plug. The vibrator holds 140 cc (approximately 1 pint).
4. Re-install oil drain plug into vibrator.

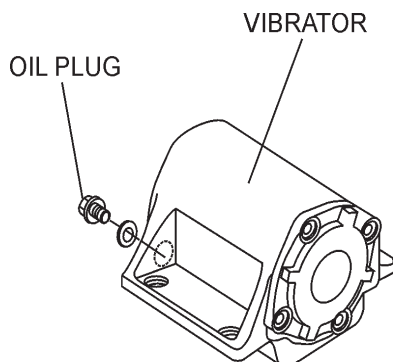

**Figure 21. Oil Level Check Plug**

## Checking and Replacing the Clutch

### Checking the Clutch

1. With belt cover removed, visually check outer drum of the clutch for seizure and "V" groove for wear or damage.
2. Clean the "V" groove as necessary.
3. Check the clutch lining and shoe for signs of wear. If the shoe is worn, replace the clutch to prevent deficient power transmission and slippage.

### Replacing the Clutch

1. Place a 19 mm offset wrench or the like onto the lower vibrator pulley fastening bolt.
2. While pulling back hard on the V-belt near the lower vibrating pulley, rotate offset wrench clockwise so that the V-belt slips off the lower vibrator pulley. Set V-belt aside.
3. Remove bolt at engine power output by giving a shock to an engaged wrench (e.g. tapping with hammer) and rotate the bolt counterclockwise.
4. Remove clutch with a pulley extractor.
5. To install a new clutch, reverse steps 1-4.

**TABLE 8. ENGINE TROUBLESHOOTING**

SYMPTOM	POSSIBLE PROBLEM	SOLUTION
Engine will not start or start is delayed, although engine can be turned over.	Speed control lever is in "STOP" position?	Set speed control lever to "START" position.
	No fuel reaching injection pump?	Add fuel. Check entire fuel system.
	Defective fuel pump?	Replace fuel pump.
	Fuel filter clogged?	Replace fuel filter and clean tank.
	Faulty fuel supply line?	Replace or repair fuel line.
	Compression too low?	Check piston, cylinder and valves. Adjust or repair per engine repair manual.
	Fuel injector not working correctly?	Repair or replace injector in accordance with engine repair manual.
	Oil pressure too low?	Check engine oil pressure.
	Low starting temperature limit exceeded	Comply with cold starting instructions and proper oil viscosity.
At low temperatures engine will not start.	Fuel separates has inadequate resistance to low temperatures?	Check whether clear (not turbid) fuel emerges from the fuel line (detach from injection pump). If the fuel is turbid or separated, warm up the engine or drain the complete fuel supply system. Refuel with winter grade diesel fuel.
	Engine oil too thick?	Refill engine crankcase with correct type of oil for winter environment.
Engine fires but stops soon as starter is switched off.	Throttle lever in STOP position?	Reposition throttle lever to RUN position.
	Fuel filter blocked?	Replace fuel filter.
	Fuel supply blocked?	Check the entire fuel system.
Engine stops by itself during normal operation.	Fuel tank empty?	Add fuel.
	Fuel filter blocked?	Replace fuel filter.
Low engine power, output and speed.	Fuel tank empty?	Fill with No.2 diesel fuel.
	Fuel filter clogged?	Replace fuel filter.
	Fuel tank venting is inadequate?	Ensure that tank is adequately vented.
	Speed control lever does not remain in selected position?	See engine manual for corrective action.
	Engine oil level too full?	Correct engine oil level?
Low engine power output and low speed, black exhaust smoke.	Air filter blocked?	Clean or replace air filter.
	Incorrect valve clearances?	Adjust valves per engine specification.
	Malfunction at injector?	See engine manual.



**TABLE 9. PLATE COMPACTOR TROUBLESHOOTING**

SYMPTOM	POSSIBLE CAUSE	SOLUTION
Travel speed too low, and vibration is weak.	Engine speed too low?	Set engine speed to correct RPM.
	Clutch slips?	Check or replace clutch.
	V-belt slips?	Adjust or replace V-belt.
	Excessive oil in vibrator?	Drain excess oil and fill to proper level.
	Malfunction in vibrator housing?	Check eccentric, gears and counter weights.
Does not travel forward.	V-belt slips?	Replace V-belt.
	Clutch slips?	Check clutch springs and shoes.
	Vibrator locked?	Check vibrator housing (eccentric, gears and counterweights)

# EXPLANATION OF CODE IN REMARKS COLUMN

The following section explains the different symbols and remarks used in the Parts section of this manual. Use the help numbers found on the back page of the manual if there are any questions.

## NOTICE

The contents and part numbers listed in the parts section are subject to change **without notice**. Multiquip does not guarantee the availability of the parts listed.

## SAMPLE PARTS LIST

NO.	PART NO.	PART NAME	QTY.	REMARKS
1	12345	BOLT.....	1	INCLUDES ITEMS W/%
2%		WASHER, 1/4 IN.....		NOT SOLD SEPARATELY
2%	12347	WASHER, 3/8 IN....	1	MQ-45T ONLY
3	12348	HOSE .....	A/R	MAKE LOCALLY
4	12349	BEARING .....	1	S/N 2345B AND ABOVE

## NO. Column

**Unique Symbols** — All items with same unique symbol

(@, #, +, %, or >) in the number column belong to the same assembly or kit, which is indicated by a note in the “Remarks” column.

**Duplicate Item Numbers** — Duplicate numbers indicate multiple part numbers, which are in effect for the same general item, such as different size saw blade guards in use or a part that has been updated on newer versions of the same machine.

## NOTICE

When ordering a part that has more than one item number listed, check the remarks column for help in determining the proper part to order.

## PART NO. Column

**Numbers Used** — Part numbers can be indicated by a number, a blank entry, or TBD.

TBD (To Be Determined) is generally used to show a part that has not been assigned a formal part number at the time of publication.

A blank entry generally indicates that the item is not sold separately or is not sold by Multiquip. Other entries will be clarified in the “Remarks” Column.

## QTY. Column

**Numbers Used** — Item quantity can be indicated by a number, a blank entry, or A/R.

A/R (As Required) is generally used for hoses or other parts that are sold in bulk and cut to length.

A blank entry generally indicates that the item is not sold separately. Other entries will be clarified in the “Remarks” Column.

## REMARKS Column

Some of the most common notes found in the “Remarks” Column are listed below. Other additional notes needed to describe the item can also be shown.

**Assembly/Kit** — All items on the parts list with the same unique symbol will be included when this item is purchased.

Indicated by:

“INCLUDES ITEMS W/(unique symbol)”

**Serial Number Break** — Used to list an effective serial number range where a particular part is used.

Indicated by:

“S/N XXXXX AND BELOW”

“S/N XXXX AND ABOVE”

“S/N XXXX TO S/N XXX”

**Specific Model Number Use** — Indicates that the part is used only with the specific model number or model number variant listed. It can also be used to show a part is NOT used on a specific model or model number variant.

Indicated by:

“XXXXX ONLY”

“NOT USED ON XXXX”

**“Make/Obtain Locally”** — Indicates that the part can be purchased at any hardware shop or made out of available items. Examples include battery cables, shims, and certain washers and nuts.

**“Not Sold Separately”** — Indicates that an item cannot be purchased as a separate item and is either part of an assembly/kit that can be purchased, or is not available for sale through Multiquip.

## SUGGESTED SPARE PARTS

---

### MQ MIKASA MVC98D2 PLATE COMPACTOR W/YANMAR L48V6 DIESEL ENGINE

#### 1 to 3 Units

<u>Qty.</u>	<u>P/N</u>	<u>Description</u>
3 .....	070100382 .....	V-BELT A38 (BLUE)
2 .....	956100050 .....	THROTTLE WIRE
3 .....	11465012590 ...	ELEMENT, A/C W/PRE-FILTER
1 .....	11429955040 ...	CAP, FUEL TANK
1 .....	11429976630 ...	ROPE, RECOIL STARTER
2 .....	11429935110 ...	LUB. OIL FILTER COMPLETE
2 .....	11425055121 ...	FILTER, FUEL STAINER
1 .....	11429955100 ...	FILTER, FUEL OIL
4 .....	939010230 .....	SOCK ABSORBER

# NAMEPLATE AND DECALS ASSY.

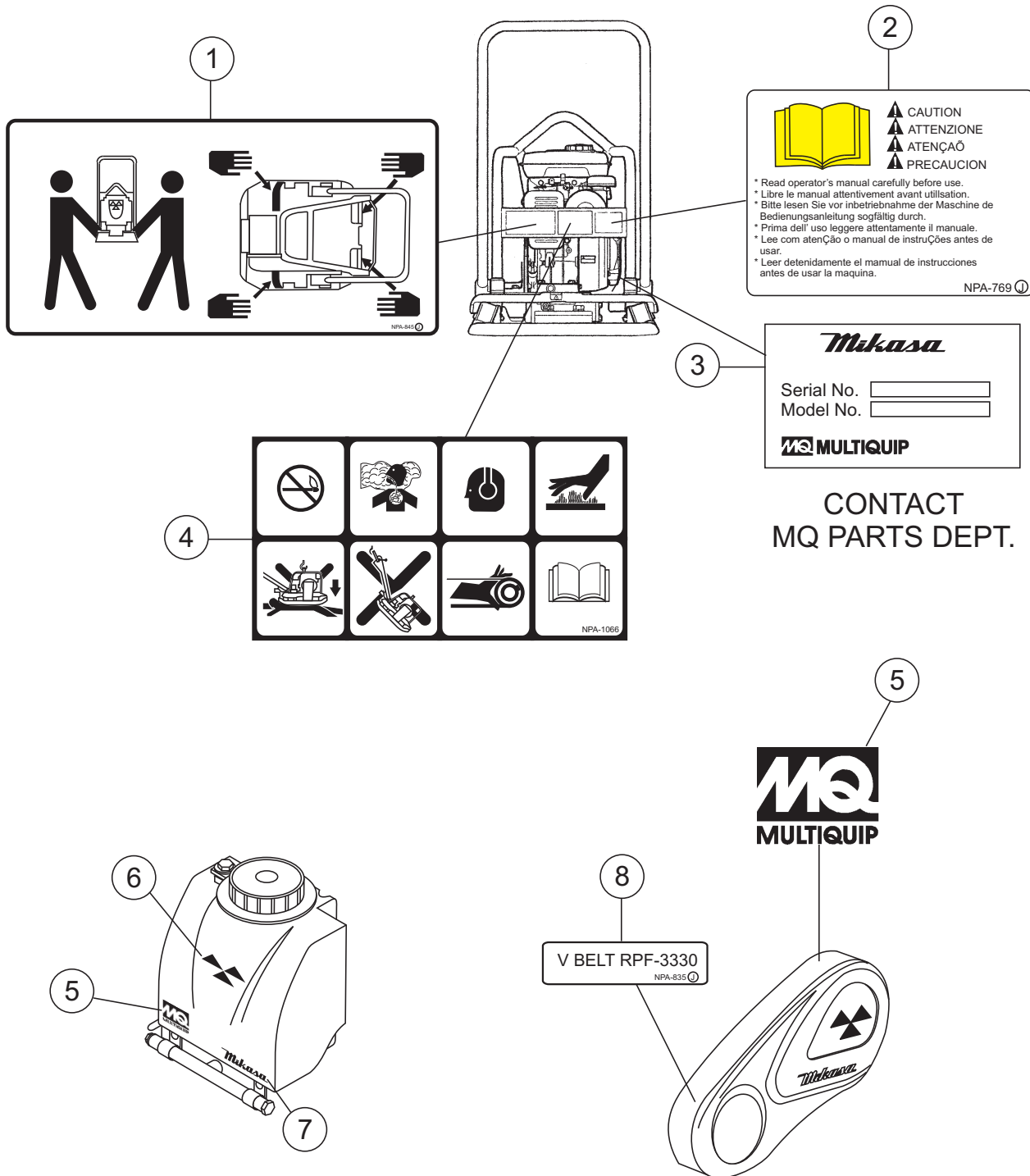

## NAMEPLATE AND DECALS ASSY.

---

<u>NO.</u>	<u>PART NO.</u>	<u>PART NAME</u>	<u>QTY.</u>	<u>REMARKS</u>
1	920208450	DECAL, LIFTING POSITION	1	NPA-845
2	920207690	DECAL, CAUTION (MANUAL)	1	NPA-769
3		PLATE, SERIAL NO .....	1 .....	CONTACT MQ PARTS DEPT.
4	920210660	DECAL, DANGER-CAUTION	1	NPA-106
5	920201580	DECAL, MQ LOGO	2	NPA-158
6	920101410	DECAL, MIKASA LOGO (TRIANGLE)	1	NPA-141
7	920105070	DECAL, MIKASA LOGO (NAME)	1	NPA-507
8	920208350	DECAL, V BELT RPF3330	1	NPA-835

# BODY ASSY.

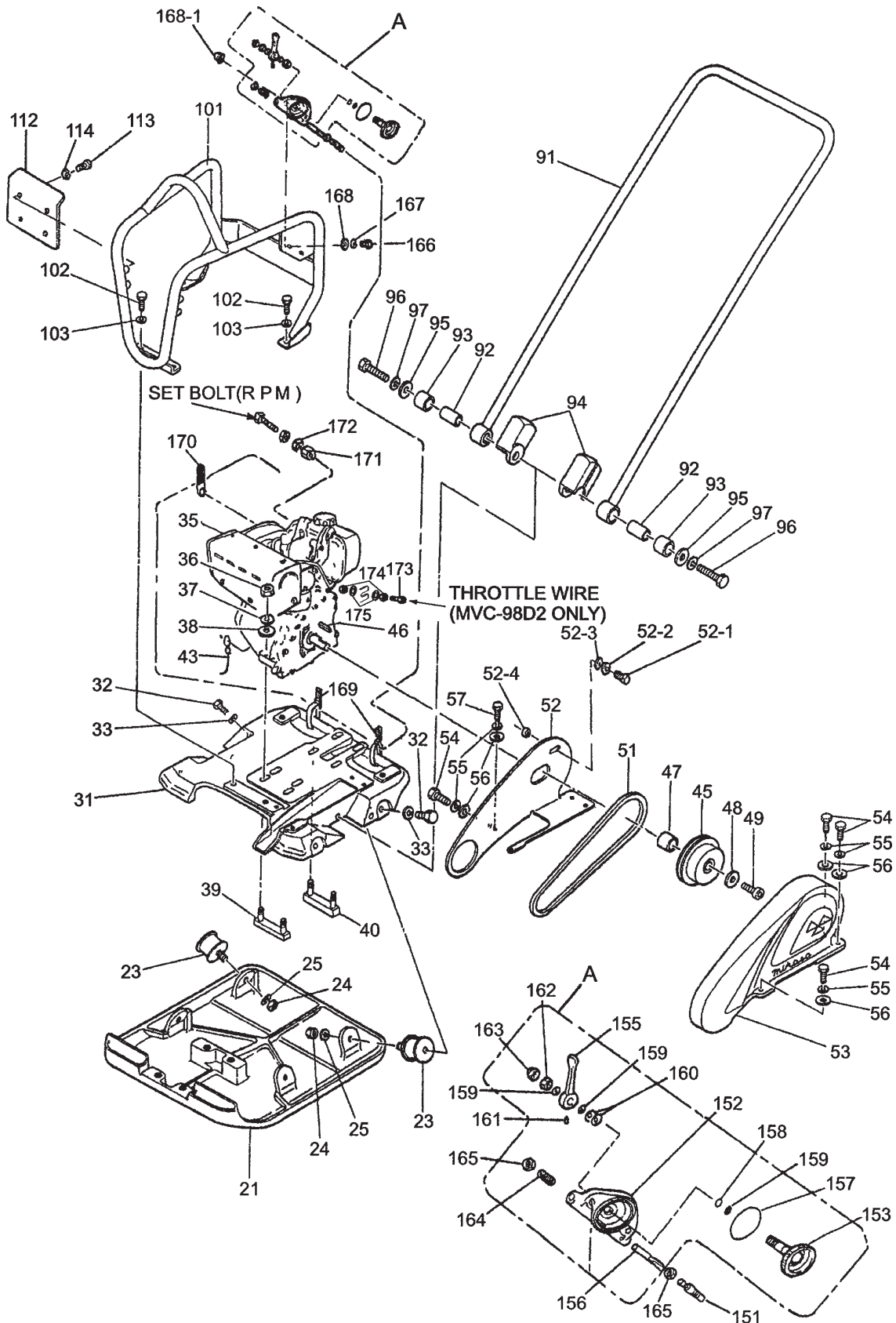

# BODY ASSY.

<u>NO.</u>	<u>PART NO.</u>	<u>PART NAME</u>	<u>QTY.</u>	<u>REMARKS</u>
21	416115973	VIBRATING PLATE	1	
23	939010230	SHOCK ABSORBER 50D- 45H	4	
24	020310080	NUT M10	4	
25	030210250	WASHER, LOCK M10	4	
31	416115980	BASE	1	
32	001221025	BOLT 10 X 25 T	4	
33	030210250	WASHER, LOCK M10	4	
35	914410024	ENGINE ASSY. L48V6F3R4AAW4	1	
36	020310080	NUT M10	4	
37	030210250	WASHER, LOCK M10	4	
38	031110160	WASHER, FLAT M10	4	
39	416456700	ENGINE PLATE /FR (W BOLT)	1	
40	416456710	ENGINE PLATE /RE (W BOLT)	1	
43	959404350	EARTH WIRE	1	
45	458337770	CLUTCH ASSY. A1- 124- 20	1	
46	0320050150	KEY	1	
47	416452760	COLLAR 20- 25- 15.6	1	
48	458451380	CLUTCH /WASHER	1	
49	001520825	SOCKET HEAD BOLT 8 X 25 T	1	
51	070100382	V- BELT A- 38 (BLUE)	1	
52	416216390	BELT COVER (INSIDE)	1	
52-1	001220825	BOLT 8 X 25 T	1	
52-2	030208200	WASHER, LOCK M8	1	
52-3	031108160	WASHER, FLAT M8	1	
52-4	952407100	WASHER 9 X 25 6	1	
53	416117760	BELT COVER	1	
54	001220825	BOLT 8 X 25 T	4	
55	030208200	WASHER, LOCK M8	5	
56	031108160	WASHER, FLAT M8	5	
57	001220820	BOLT 8 X 20 T	1	
91	416115930	HANDLE	1	
92	416452730	COLLAR 13- 20- 44	2	
93	404433430	RUBBER 20 X 32 X 28.5	2	
94	416452360	HANDLE STOPPER	2	
95	952405600	WASHER 12.5 X 35 X 4.5	2	
96	001221253	BOLT 12X65 T	2	
97	030212300	WASHER, LOCK M12	2	
101	416117520	GUARD HOOK	1	
102	001221025	BOLT 10 X 25 T	4	
103	030210250	WASHER, LOCK M10	4	
112	416342980	MUFFLER GUARD	1	
113	001220820	BOLT 8 X 20 T	4	
114	030208200	WASHER, LOCK M8	4	

# BODY ASSY.

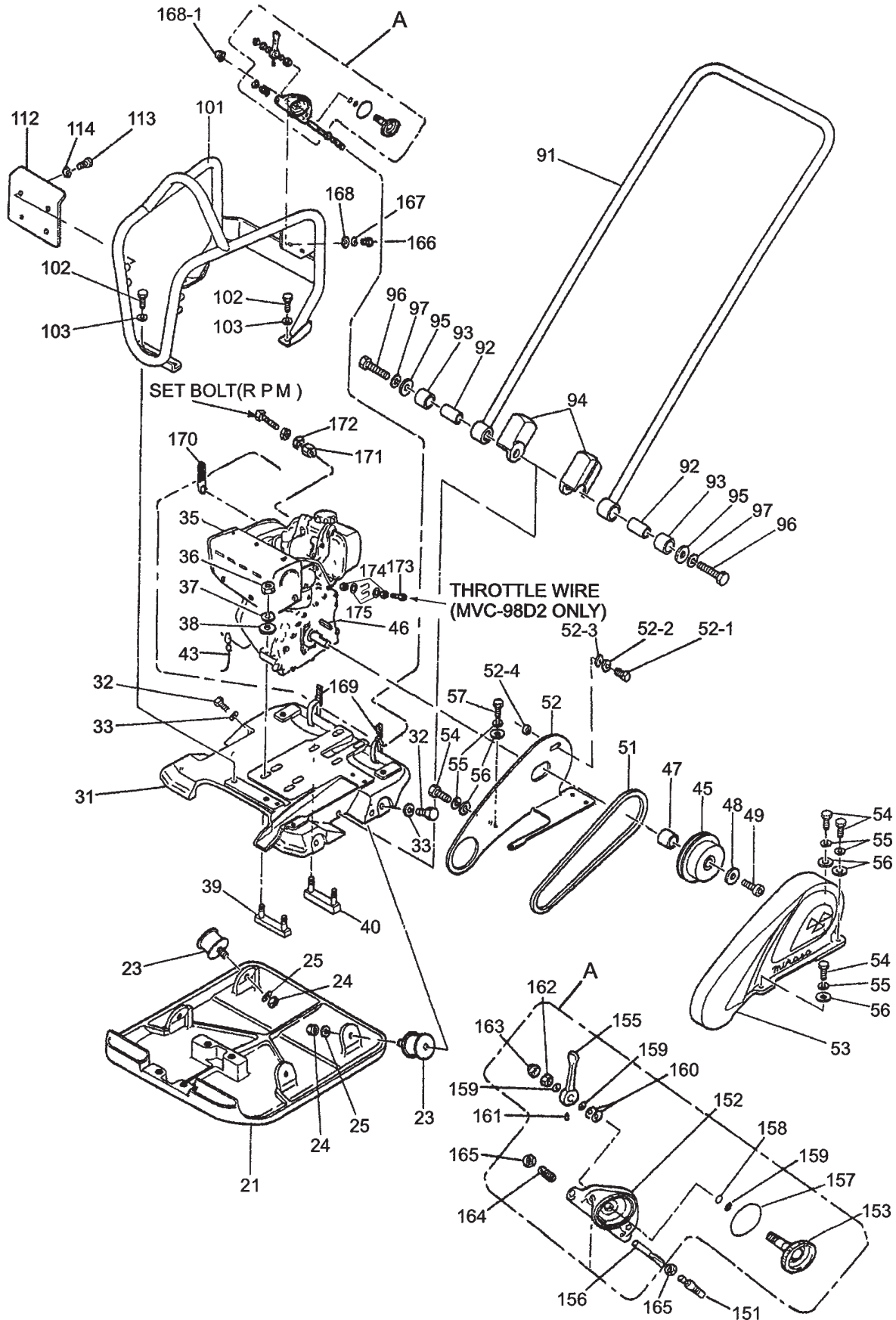



# BODY ASSY.

## CONTINUED

<u>NO.</u>	<u>PART NO.</u>	<u>PART NAME</u>	<u>QTY.</u>	<u>REMARKS</u>
A	362910060	THROTTLE LEVER ASSY. ....	1	INCLUDES ITEMS W/*
151	956100050	THROTTLE WIRE 845- 1010	1	
152*	362341550	THROTTLE BODY	1	
153*	362910090	THROTTLE GEAR CP, W/BOLT	1	
155*	362455630	THROTTLE LEVER	1	
156	362455620	SLIDER	1	
157*	050100450	O- RING G- 45	1	
158*	050200100	O- RING P- 10	1	
159*	031110160	WASHER, FLAT M10	3	
160*	032110180	CONICAL SPRING WASHER M10	2	
161*	096206006	SOCKET HEAD SCREW 6X6	1	
162*	020410060	NUT M10, H=6	1	
163*	022131008	CAP NUT M10	1	
164*	*096208020	SOCKET HEAD SCREW 8X20	1	
165*	020408050	NUT M8, H=5	1	
166	001220620	BOLT 6X20 T	2	
167	030206150	WASHER, LOCK M6	2	
168	031106100	WASHER, FLAT M6	2	
168-1	022130605	CAP NUT M6	2	
169	511010040	CLAMP TC- 300	3	
170	954406820	CLAMP CORD	1	
171	959406800	NUT M6, SPECIAL- L10	1	
172	020306050	NUT M6	1	
173	10210067080	ADJUSTING BOLT	1	
174	020306050	NUT M6	2	
175	952401690	WASHER 7173	2	

**VIBRATION ASSY.**

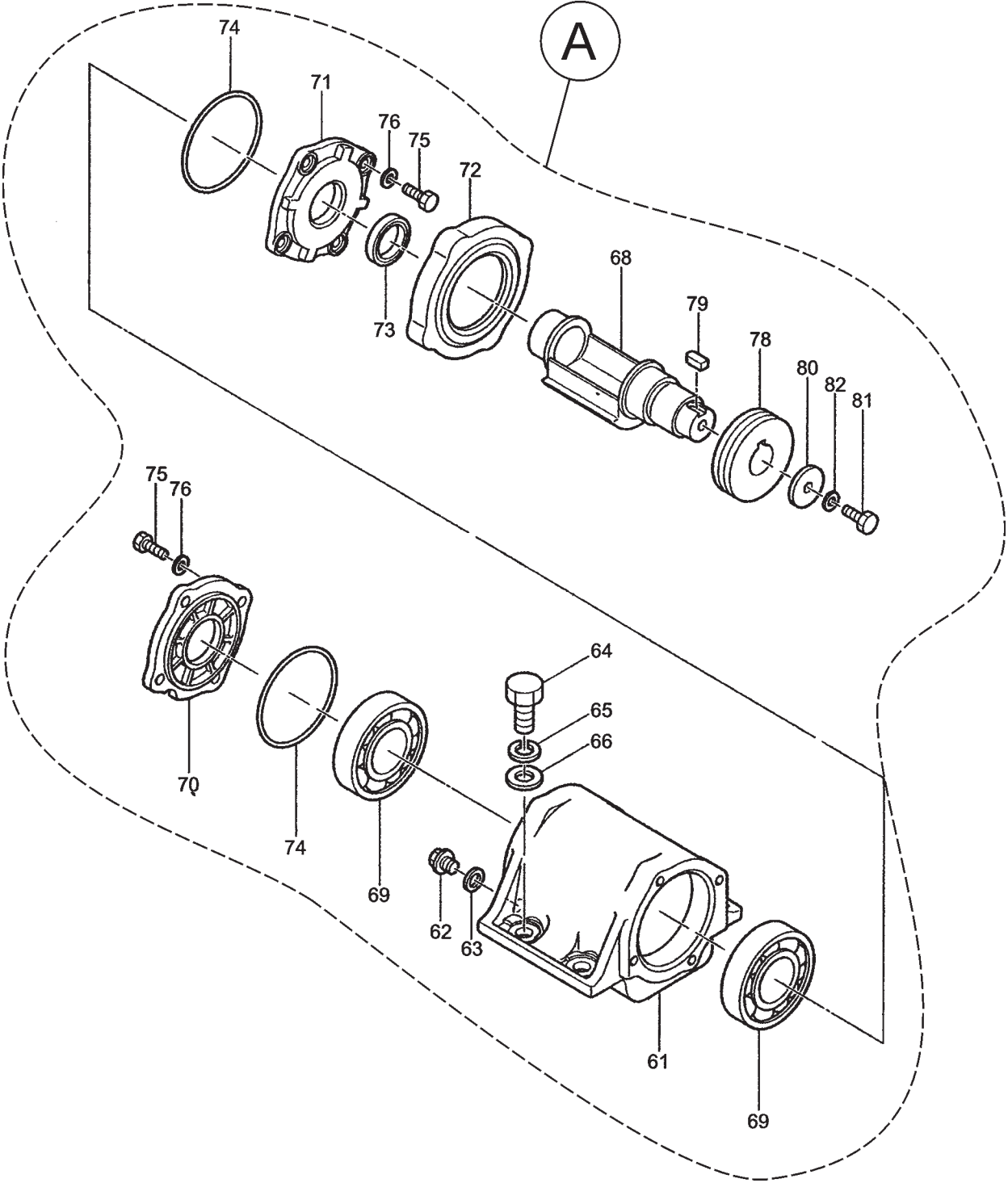

## VIBRATION ASSY.

---

<u>NO.</u>	<u>PART NO.</u>	<u>PART NAME</u>	<u>QTY.</u>	<u>REMARKS</u>
A	416910030	VIBRATOR ASSY. ....	1	INCLUDES ITEMS W/*
61*	416115991	VIBRATING CASE	1	
62*	953400170	PLUG 1/4" X 14 10L	1	
63*	953405260	PACKING 1/4 (CU)	1	
64*	001221640	BOLT 16 X 40 T	4	
65*	939216499	WASHER, LOCK M16	4	
66*	031116260	WASHER, FLAT M16	4	
68*	416215530	ECCENTRIC ROTATOR	1	
69*	040406211	BEARING 6211C4	2	
70*	416338900	CASE COVER (R)	1	
71*	416338910	CASE COVER (L)	1	
72*	416338920	BELT COVER GUARD	1	
73*	060803060	OIL SEAL TC- 35488	1	
74*	050101000	O- RING G-100	2	
75*	001220825	BOLT 8X25 T	8	
76*	030208200	WASHER, LOCK M8	8	
78*	416454430	PULLEY A1- 28- 81- 20	1	
79*	951405240	KEY 7X7X19 R	1	
80*	952404250	WASHER 11 X 40X 4	1	
81*	001221025	BOLT 10X25 T	1	
82*	030210250	WASHER, LOCK M10	1	

# WATER TANK ASSY.

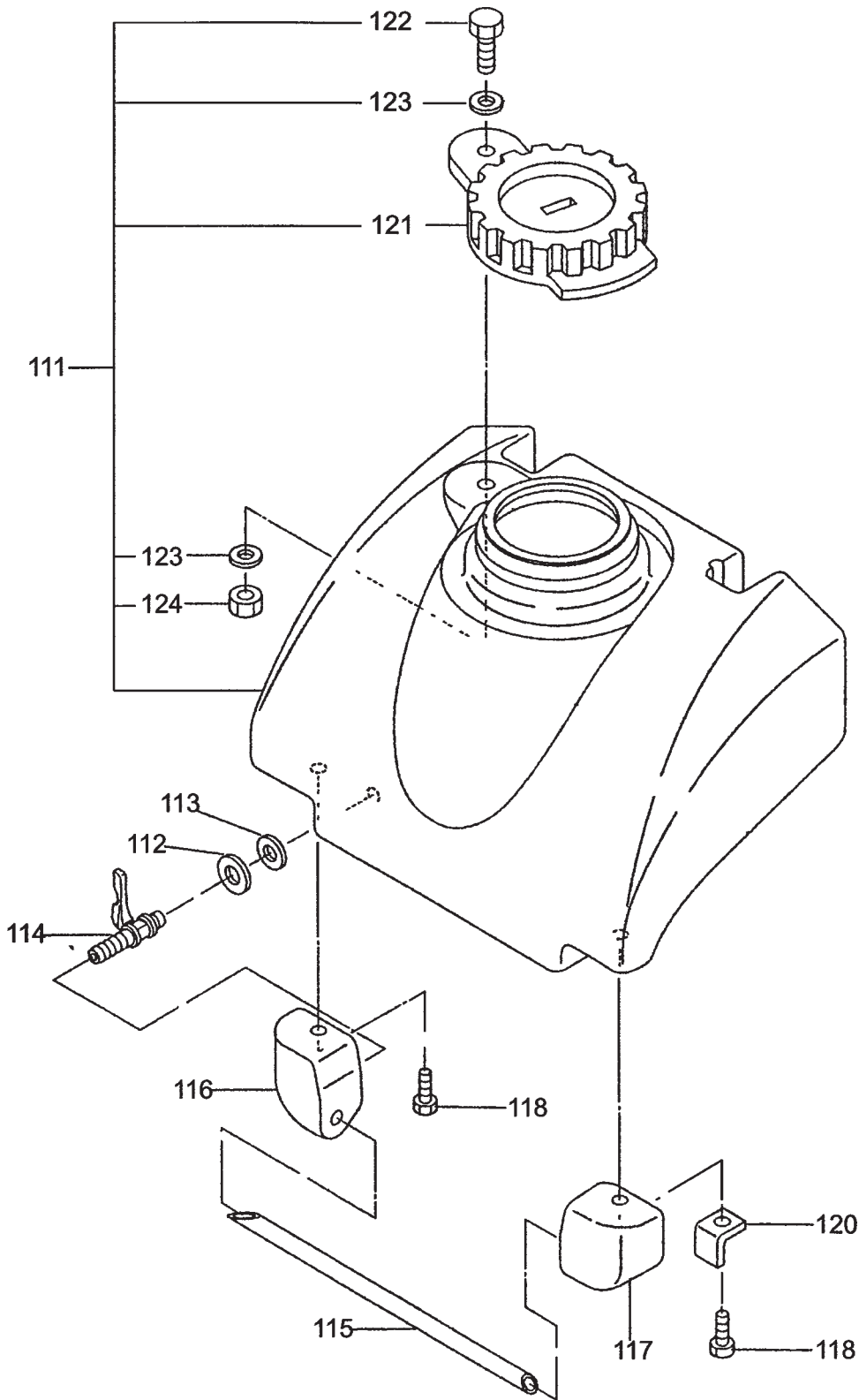

## WATER TANK ASSY.

---

<u>NO.</u>	<u>PART NO.</u>	<u>PART NAME</u>	<u>QTY.</u>	<u>REMARKS</u>
111	416910010	WATER TANK ASSY. (ORANGE) .....	1 .....	INCLUDES ITEMS W/*
112	033910050	WASHER 14.5 X 30 X 1.6	1	
113	953406390	PACKING 13 X 28 X 2		
114	954403241	COCK PT1/4", BH-1211 (AL)	1	
115	416338930	SPRINKLING PIPE	1	
116	416338940	PIPE HOLDER (L)	1	
117	416452750	PIPE HOLDER (R)	1	
118	001740825	FLANGE BOLT 8X25 (SUS)	2	
120	416452790	PIPE HOLDER STAY	1	
121*	954300342	WATER TANK CAP (NBR)	1	
122*	001241030	BOLT 10X30 U	1	
123*	033910010	WASHER 10.5 X 21 X 2 (SUS)	2	
124*	022910180	NYLON NUT M10 (SUS)	1	

# TRANSPORT WHEEL ASSY.

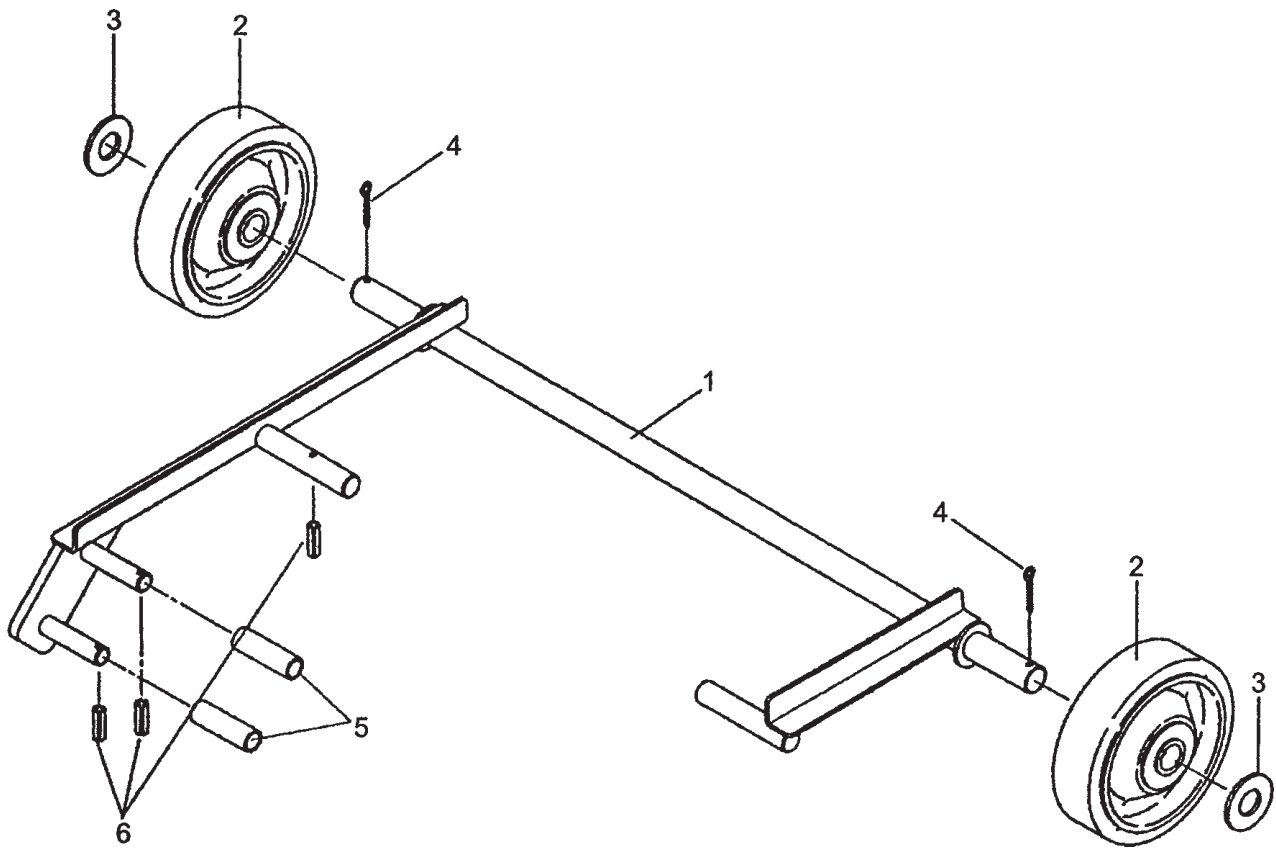

## TRANSPORT WHEEL ASSY.

---

<u>NO.</u>	<u>PART NO.</u>	<u>PART NAME</u>	<u>QTY.</u>	<u>REMARKS</u>
1	416116160	WHEEL SHAFT	1	
2	959404310	WHEEL 150X42	2	
3	031120320	WASHER, FLAT M20	2	
4	025203030	SPLIT COTTER PIN 3X30	2	
5	416454150	ROLLER	2	
6	025403025	SPRING PIN 3X25	3	

# CYLINDER BLOCK ASSY.

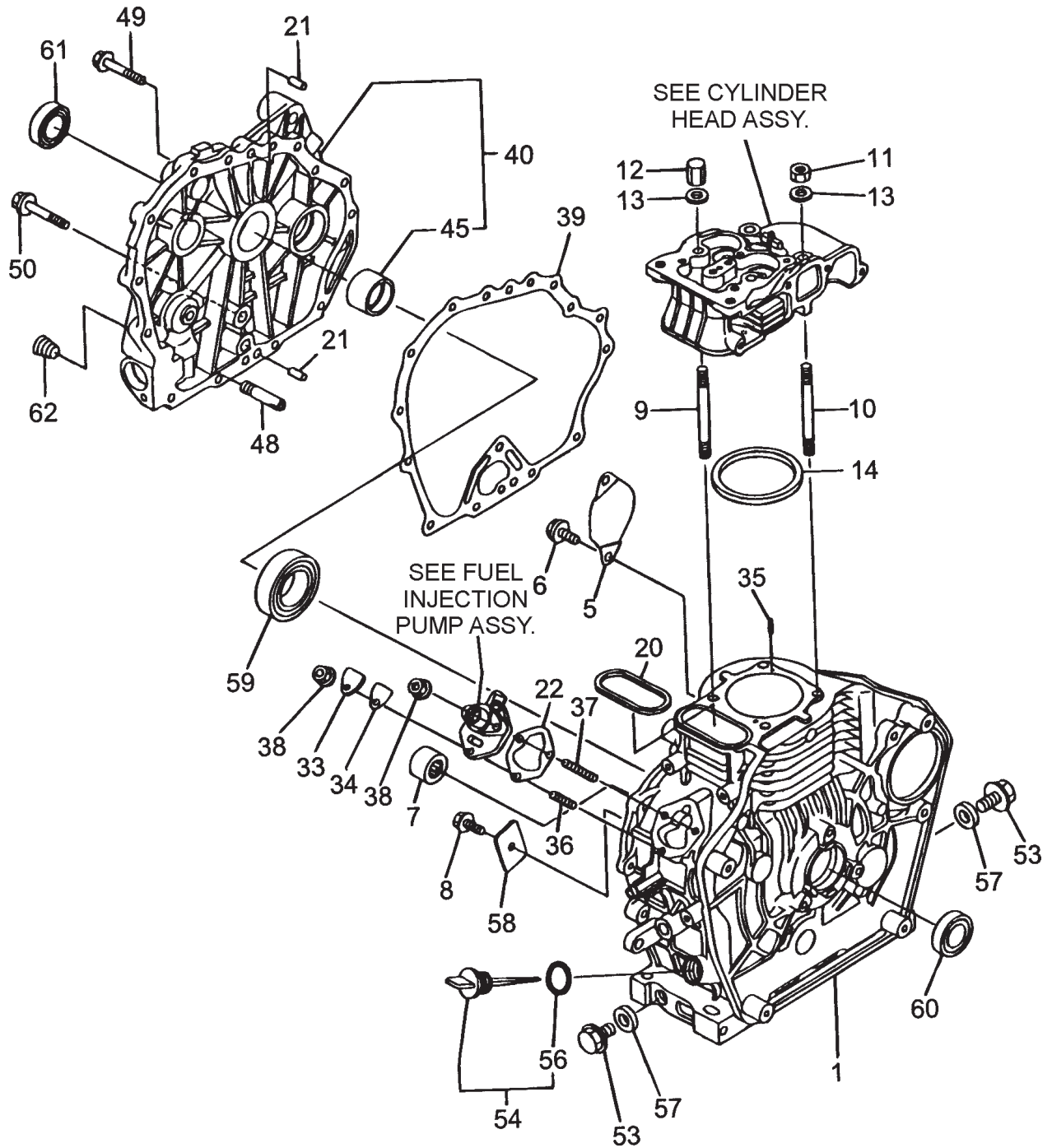



## CYLINDER BLOCK ASSY.

<u>NO.</u>	<u>PART NO.</u>	<u>PART NAME</u>	<u>QTY.</u>	<u>REMARKS</u>
1	11429501050	CYLINDER BLOCK ASSY.	1	
5	11439901700	STARTER COVER	1	
6	26106100122	BOLT M10X 12 PLATED	2	
7	24162152112	NEEDLE BEARING	1	
8	26106080122	BOLT M 8X 12 PLATED	1	
9	11429901200	CYLINDER HEAD BOLT A	2	
10	11429901210	CYLINDER HEAD BOLT B	2	
11	11429901220	CYLINDER HEAD NUT A	2	
12	11429901230	CYLINDER HEAD NUT B	2	
13	12495001250	WASHER	4	
14	11429501330	CYLINDER HEAD GASKET ASSY.	1	
20	11429901380	O- RING	1	
21	11429901600	PIN 8X12	2	
22	11429901800	SHIM SET	1	
33	11429901830	COVER, (FO PUMP)	1	
34	11425001841	GASKET	1	
35	22312040080	PIN 4X8 STRAIGHT	2	
36	26226060182	STUD M 6X 18 PLATED	1	
37	26226060222	STUD M 6X 22 PLATED	2	
38	26366060002	NUT M 6	3	
39	11429901410	CRANK CASE GASKET	1	
40	11428401452	CRANK CASE COVER .....	1	INCLUDES ITEMS W/*
45*	11425002100	MAIN BEARING US=STD.	1	
45	11425002200	BEARING US=0.25, MAIN	1	
45	11425002210	BEARING US=0.50, MAIN	1	
48	11429935150	L.O. INLET PIPE	1	
49	26106060252	BOLT M 6X 25 PLATED	14	
50	26106080352	BOLT M 8X 35 PLATED	1	
53	11429901690	PLUG M16	2	
54	11429901760	CAP, W/LUBE OIL GAUGE .....	1	INCLUDES ITEMS W/#
56#	11429901950	O- RING	1	
57	22190160002	SEAL WASHER 16S	2	
58	11429902030	RETAINER	1	
59	11425002113	BALL BEARING	1	
60	11429902220	OIL SEAL	1	
61	16021002220	OIL SEAL	1	
62	23876010000	PLUG PT 1/8, SCREW	1	

# CYLINDER HEAD ASSY.

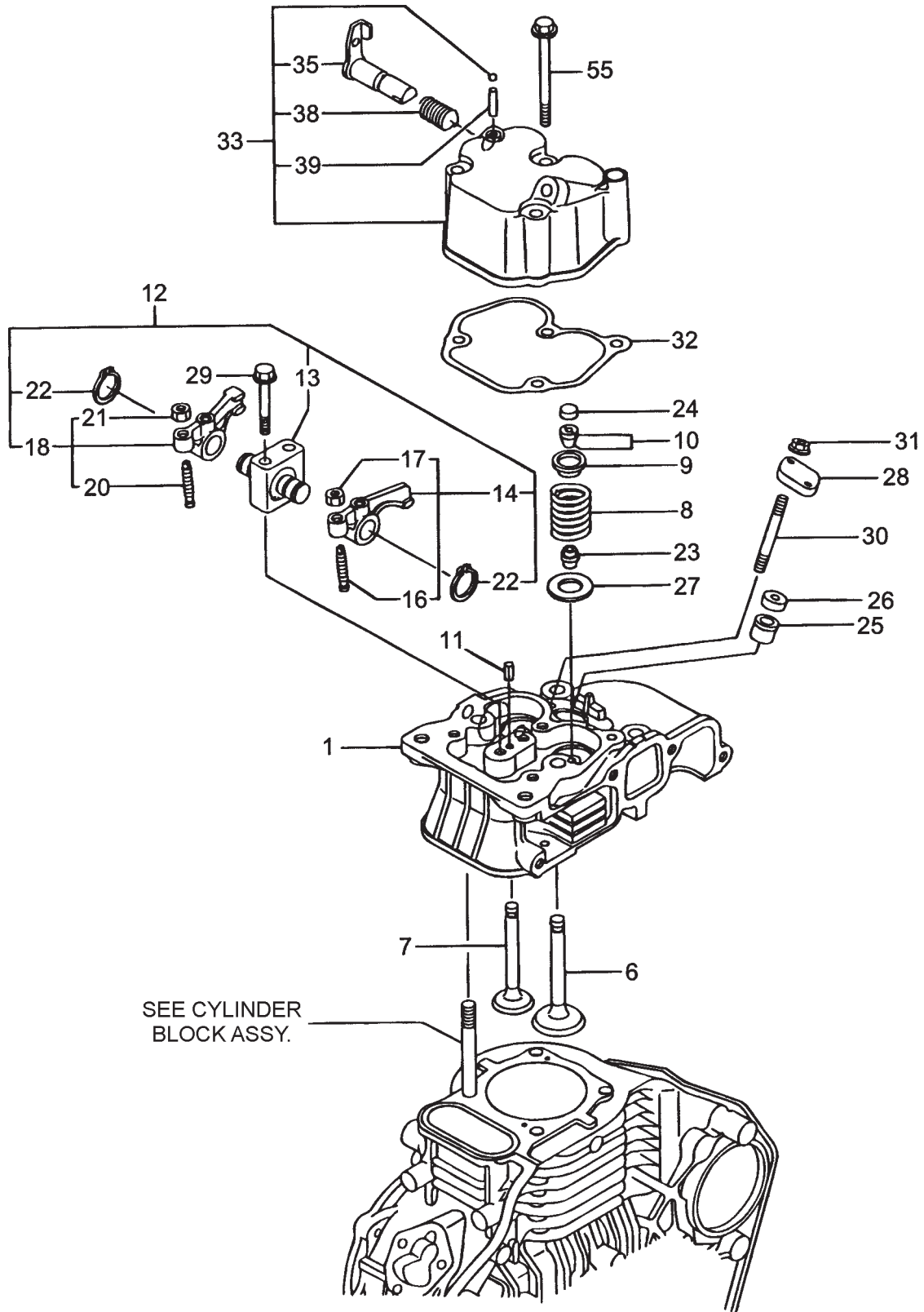

## CYLINDER HEAD ASSY.

<u>NO.</u>	<u>PART NO.</u>	<u>PART NAME</u>	<u>QTY.</u>	<u>REMARKS</u>
1	11477111020	CYLINDER HEAD	1	
6	11477111100	SUCTION VALVE	1	
7	11477111110	EXHAUST VALVE	1	
8	11429911120	VALVE SPRING	2	
9	1142511180	SPRING RETAINER	2	
10	27310055001	COTTER	2	
11	22351040008	SPRING PIN 4X8	1	
12	11477111250	ARM SUPPORT CAM .....	1	INCLUDES ITEMS W/*
13*	11477111260	ROCKER ARM SUPPORT	1	
14*	11477111650	INTAKE ARM ASSY. ....	1	INCLUDES ITEMS W/%
16%	11425011240	VALVE ADJUST. SCREW	1	
17%	26856060002	LOCK NUT 6	1	
18*	11477111660	EXHAUST ARM ASSY. ....	1	INCLUDES ITEMS W/\$
20\$	11425011240	VALVE ADJUST. SCREW	1	
21\$	26856060002	LOCK NUT 6	1	
22*	22242000120	CIR CLIP 12	2	
23	11425011340	VALVE STEM SEAR	2	
24	11926011370	VALVE CAP	2	
25	11477111461	NOZZLE GASKET	1	
26	11429511470	NOZZLE SPACER	1	
27	11429911600	VALVE SPRING WASHER	2	
28	11429911901	NOZZLE RETAINER	1	
29	26106060452	BOLT M 6X45 PLATED	2	
30	11471811910	STUD BOLT M6X65	2	
31	26366060002	NUT M 6	2	
32	11477111310	BONNET GASKET	1	
33	11429511951	BONNET COMPLETE .....	1	INCLUDES ITEMS W/#
35#	11425003591	SHAFT ASSY. DECOMP.	1	
38#	11429903640	SPRING, DECOMP.	1	
39#	22312030160	PARALLEL PIN 3X16	1	
55	26106060552	BOLT M 6X 55 PLATED	3	

# AIR CLEANER ASSY.

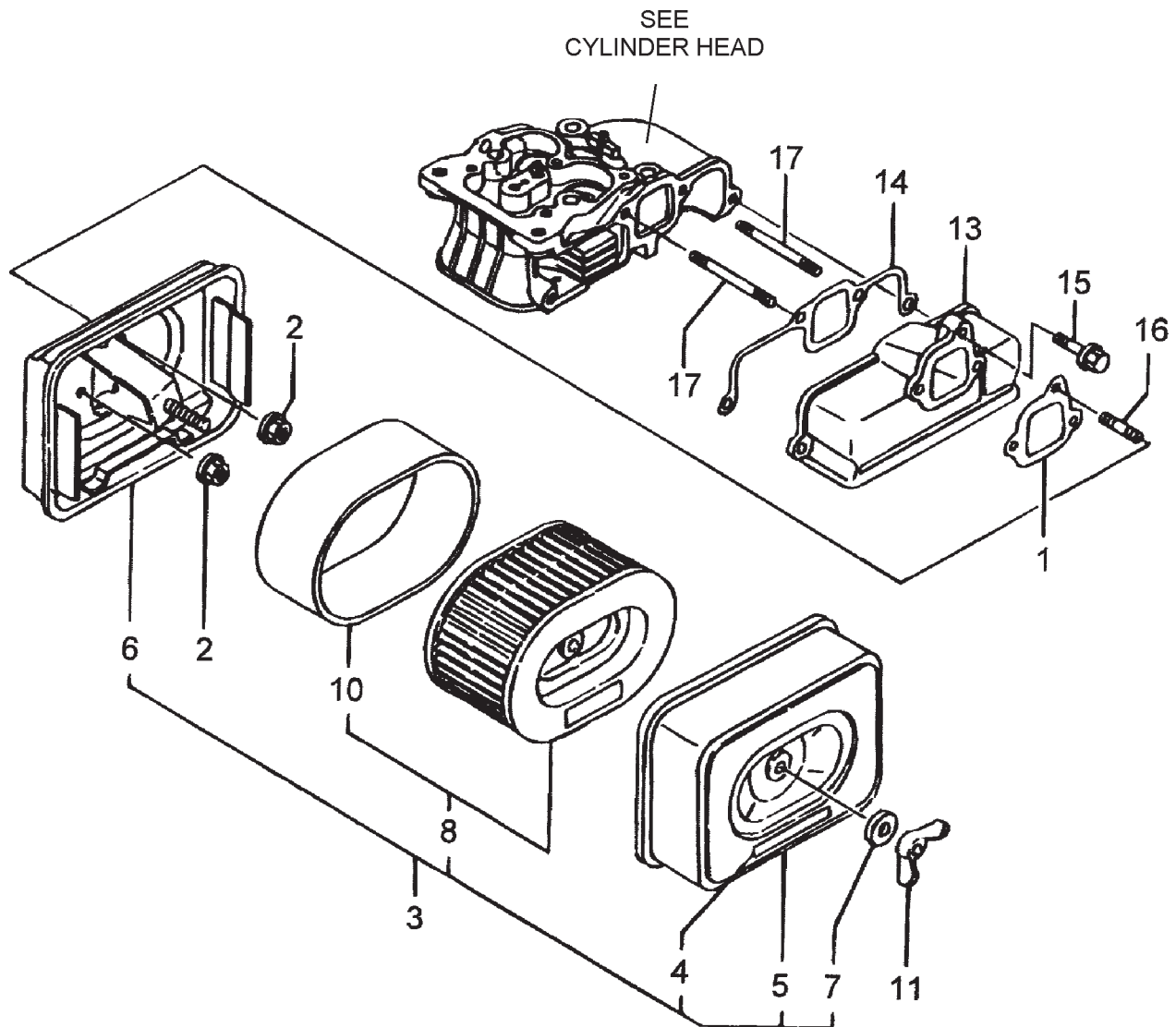

## AIR CLEANER ASSY.

---

<u>NO.</u>	<u>PART NO.</u>	<u>PART NAME</u>	<u>QTY.</u>	<u>REMARKS</u>
1	11429912210	GASKET, AIR CLEANER	1	
2	11429912300	U- NUT	3	
3	11428812511	CLEANER, AIR ASSY. ....	1	INCLUDES ITEMS W/*
4*	11465007450	LABEL, AIR CLEANER	1	
5*	11428812520	COVER COMPL.	1	
6*	11428812532	CASE, AIR CLEANER	1	
7*	11425212560	SEAL WASHER M8	1	
8*	11465012590	ELEMENT W/ PRE- FILTER.....	1	INCLUDES ITEMS W/\$
10*\$	11465012550	PRE- FILTER	1	
11	11425212550	WING NUT M8		
13	11477112010	INTAKE MANIFOLD	1	
14	11477112200	AIR INTAKE GASKET	1	
15	26106060252	BOLT M 6X 25 PLATED	2	
16	26226060142	STUD M 6X14 PLATED	1	
17	26226060552	STUD M 6X 55	2	

# MUFFLER ASSY.

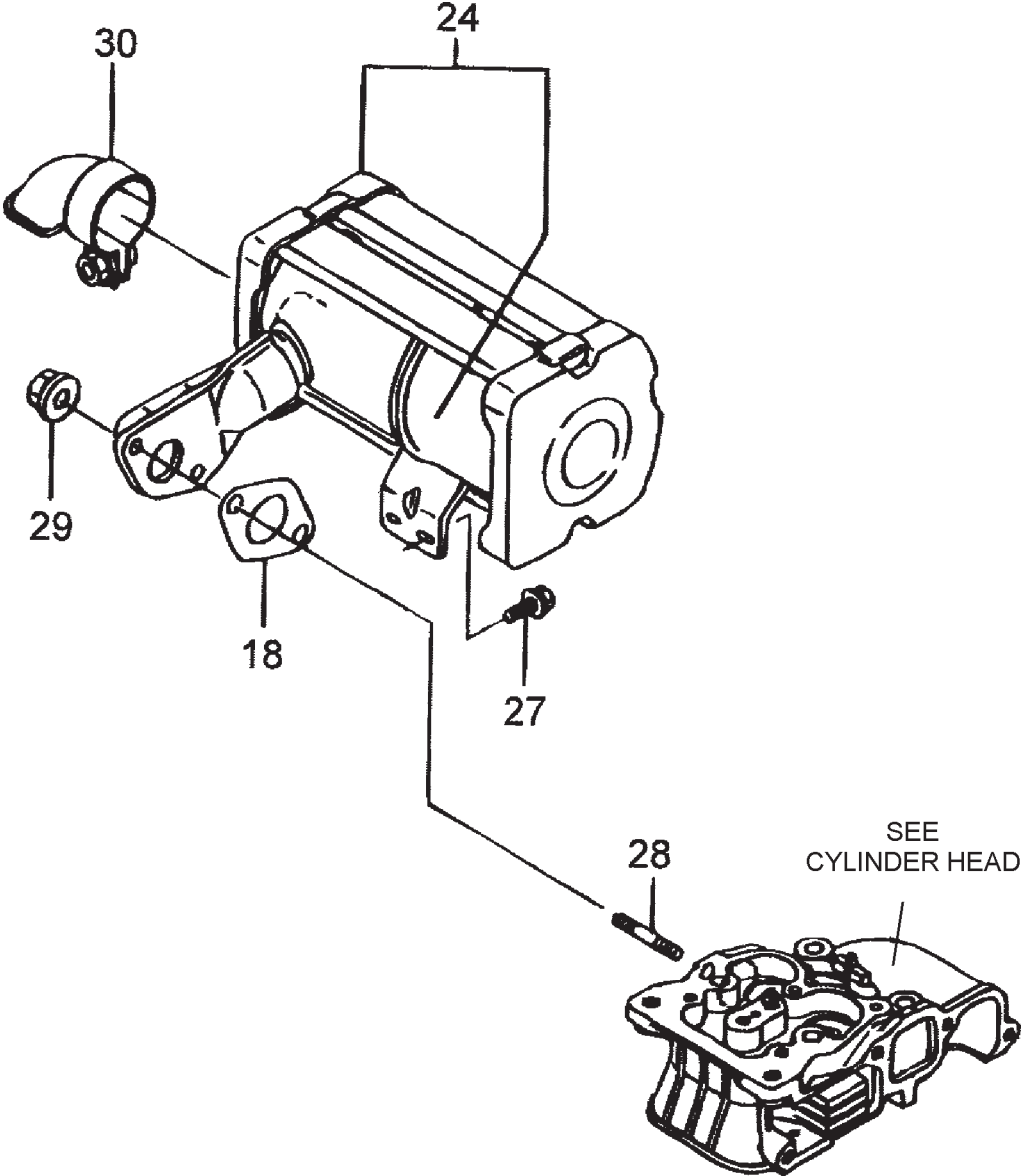

## MUFFLER ASSY.

---

<u>NO.</u>	<u>PART NO.</u>	<u>PART NAME</u>	<u>QTY.</u>	<u>REMARKS</u>
18	11429913200	MUFFLER GASKET	1	
24	11428813500	MUFFLER ASSY.	1	
27	26106060142	BOLT M6X14 PLATED	2	
28	26216080182	STUD M 8X 18 PLATED	2	
29	26366080002	NUT M 8	2	
30	11429913800	EXHAUST DEFLECTOR	1	

# CRANKSHAFT AND CAMSHAFT ASSY.

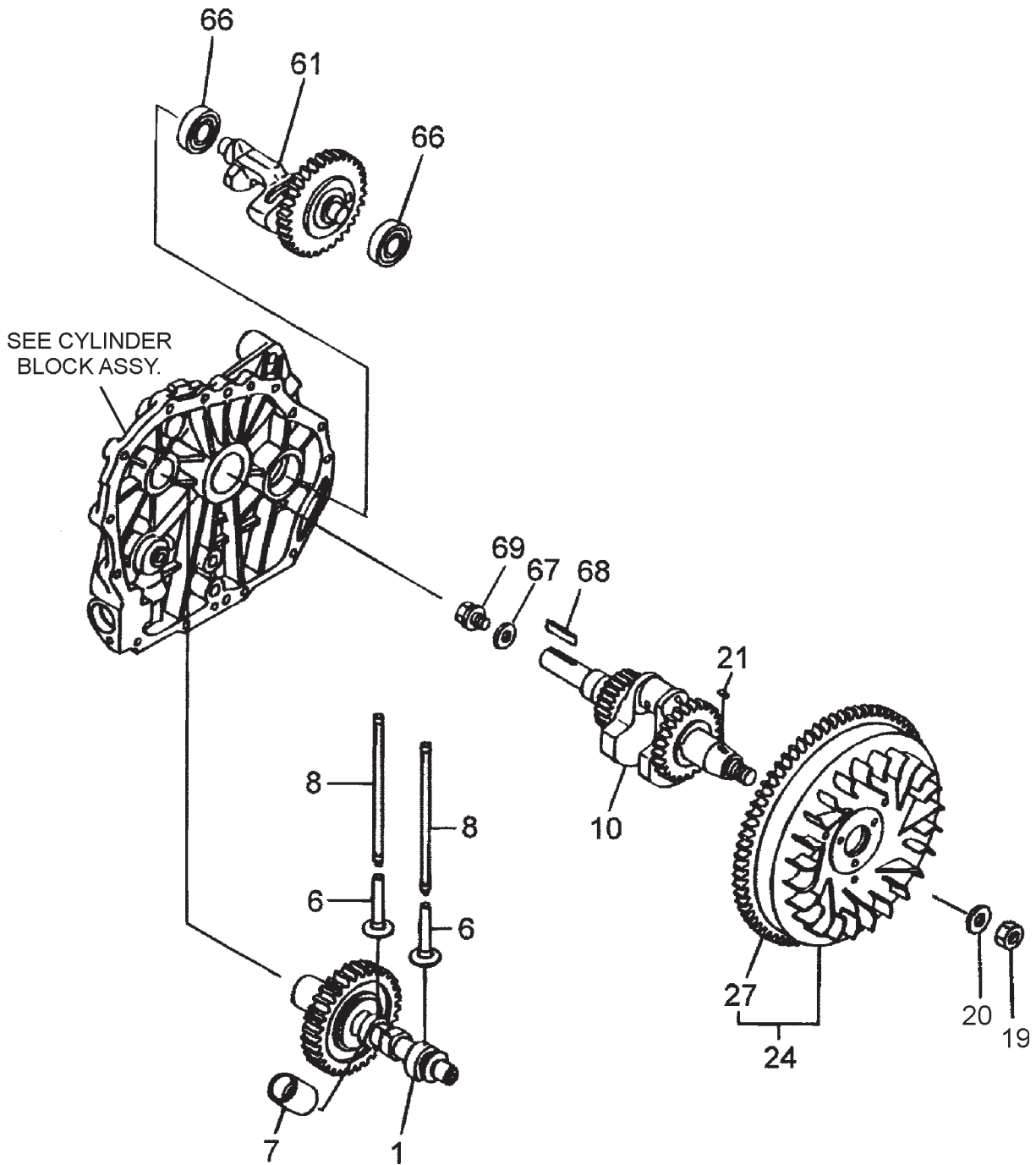



## CRANKSHAFT AND CAMSHAFT ASSY.

---

<u>NO.</u>	<u>PART NO.</u>	<u>PART NAME</u>	<u>QTY.</u>	<u>REMARKS</u>
1	71429514580	CAMSHAFT (D) ASSY.	1	
6	11429914200	TAPPET	2	
7	11477114260	TAPPET, F.O.	1	
8	11425014451	PUSH ROD	2	
10	71477221701	CRANKSHAFT ASSY.	1	
19	11429921220	NUT	1	
20	11429921550	FLYWHEEL WASHER	1	
21	22512040120	KEY 4X 12	1	
24	11429921590	FLYWHEEL ASSY. ....	1	INCLUDES ITEMS W/*
27*	11426221600	RING GEAR	1	
61	71477028531	SHAFT ASSY. BEARING	1	
66	24101062020	BEARING 6202	2	
67	16031014550	WASHER	1	
68	22512050300	KEY 5X30	1	
69	26106080202	BOLT M8 X20 PLATED	1	

# PISTON ASSY.

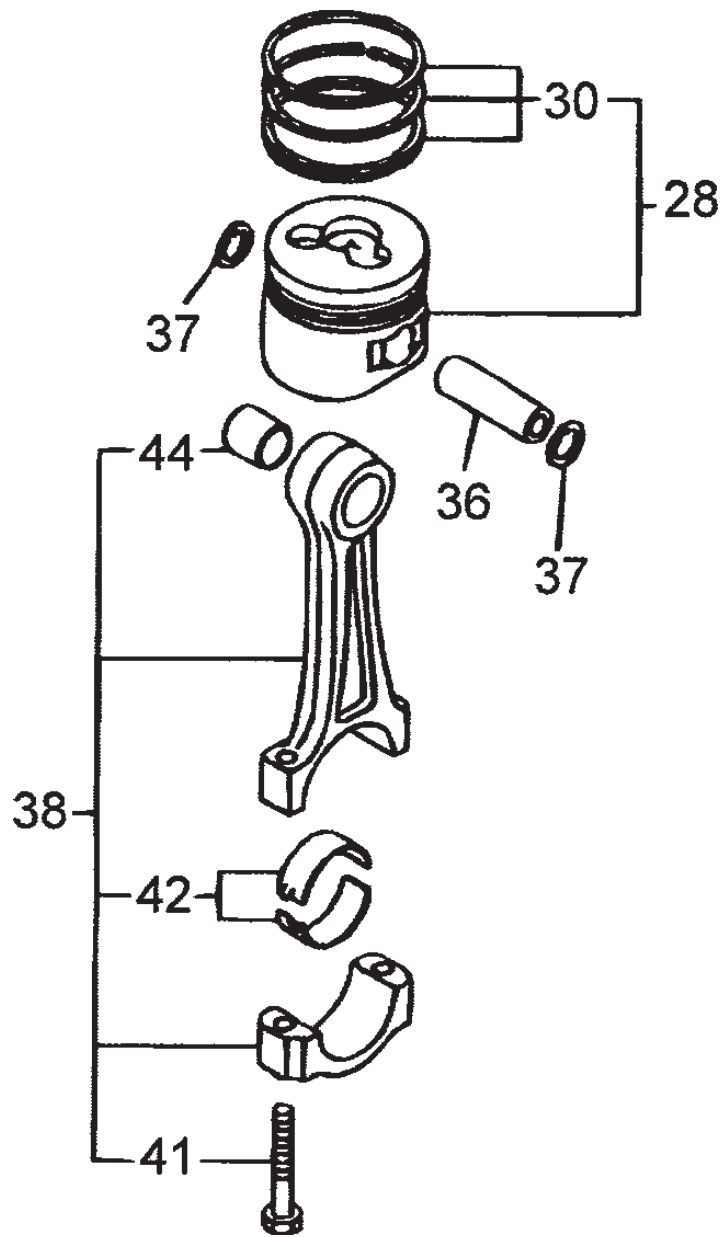

## PISTON ASSY.

---

<u>NO.</u>	<u>PART NO.</u>	<u>PART NAME</u>	<u>QTY.</u>	<u>REMARKS</u>
28	71429522720	PISTON W/RINGS (D) STD. ....	1 .....	INCLUDES ITEMS W/#
28	71429522620	PISTON W/RING OS=0.25 .....	1 .....	INCLUDES ITEMS W/#
28	71429522580	PISTON W/RING OS=0.50 .....	1 .....	INCLUDES ITEMS W/#
30#	71429522500	PISTON RING SET STD.	1	
30#	71429522540	PISTON RING SET OS=0.25	1	
30#	71429522550	PISTON RING SET OS=0.50	1	
36	11429922300	PISTON PIN	1	
37	22252000190	CIRCLIP 19	2	
38	71429923700	CONNECTING ROD ASSY. ....	1 .....	INCLUDES ITEMS W/*
41*	11926523200	ROD BOLT	2	
42*	71477023600	CRANKPIN BEARING U.S=STD.	1	
42	71477023610	CRANKPIN BEARING U.S=0.25	1	
42	71477023620	CRANKPIN BEARING U.S=0.50	1	
44*	11477023100	PISTON PIN BUSH	1	

# LUB. OIL PUMP AND GOVERNOR ASSY.

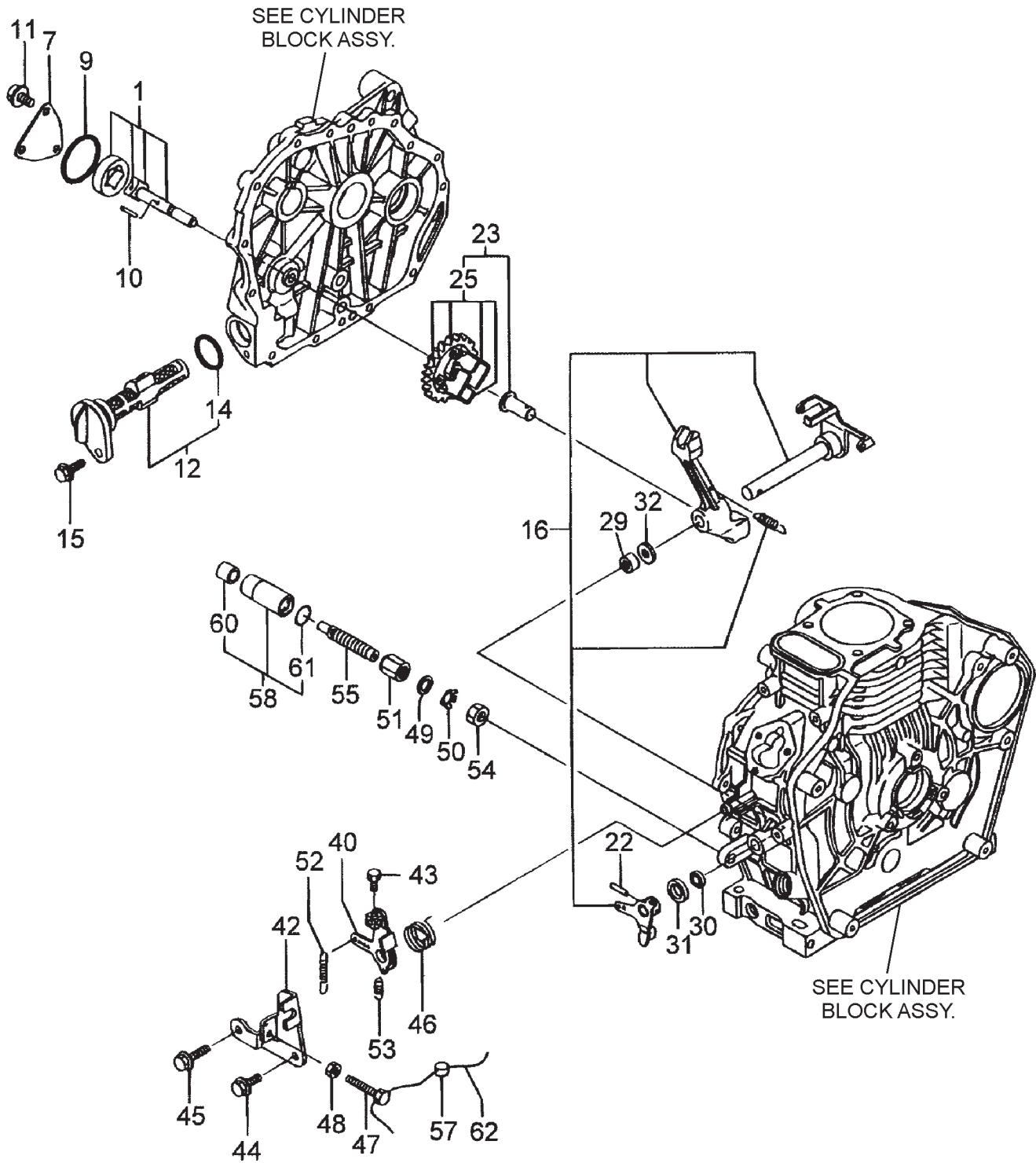

## LUB. OIL PUMP AND GOVERNOR ASSY.

<u>NO.</u>	<u>PART NO.</u>	<u>PART NAME</u>	<u>QTY.</u>	<u>REMARKS</u>
1	11425032010	LUB. OIL PUMP ASSY.	1	
7	11429932070	LUB. OIL PUMP COVER	1	
9	11429932570	O- RING COVER	1	
10	22312030160	PARALLEL PIN 3X16	1	
11	26106060122	BOLT M 6X 12 PLATED	3	
12	11429935110	LUB. OIL FILTER COMPLETE .....	1	INCLUDES ITEM W/#
14#	24341000224	O- RING 1A S- 22.4	1	
15	26106060162	BOLT M 6X 16 PLATED	1	
16	11429561190	GOVERNOR LEVER ASSY.	1	
22	22322030200	TAPER PIN 3X20	1	
23	71477061100	GOVERNOR ASSY. ....	1	INCLUDES ITEM W/*
25*	11477061220	GOVERNOR WEIGHT ASSY.	1	
29	11477061520	NEEDLE BEARING	2	
30	11429961600	OIL SEAL	1	
31	11477061610	THRUST WASHER	1	
32	11429961190	GOVERNOR WASHER	1	
40	11425266051	REGULATOR HANDLE	1	
42	18336060202	REGULATOR BRACKET	1	
43	10522566990	SCREW	1	
44	26106060142	BOLT M 6X 14 PLATED	1	
45	26106060202	BOLT M6X20 PLATED	1	
46	11429966440	RETURN SPRING	1	
47	11429966440	ADJUSTING BOLT	1	
48	26757060002	LOCK NUT M 6 PLATED	2	
49	11477161810	PLAIN WASHER 14	1	
50	11477161830	PLATE	1	
51	11429561940	NUT	1	
52	11429966010	REGULATOR SPRING	1	
53	11429966200	RETURN SPRING	1	
54	11477166690	NUT M14	1	
55	11481866600	FUEL LIMITER ASSY.	1	
57	13521061090	LEAD	1	
58	11477161890	PROTECTOR CMP .....	1	INCLUDES ITEMS W/+
60+	11477161960	SPACER	1	
61+	24311000180	O- RING 1A P-18.0	1	
62	22451060000	WIRE 0.6	1	

# COOLING AND STARTING DEVICE ASSY.

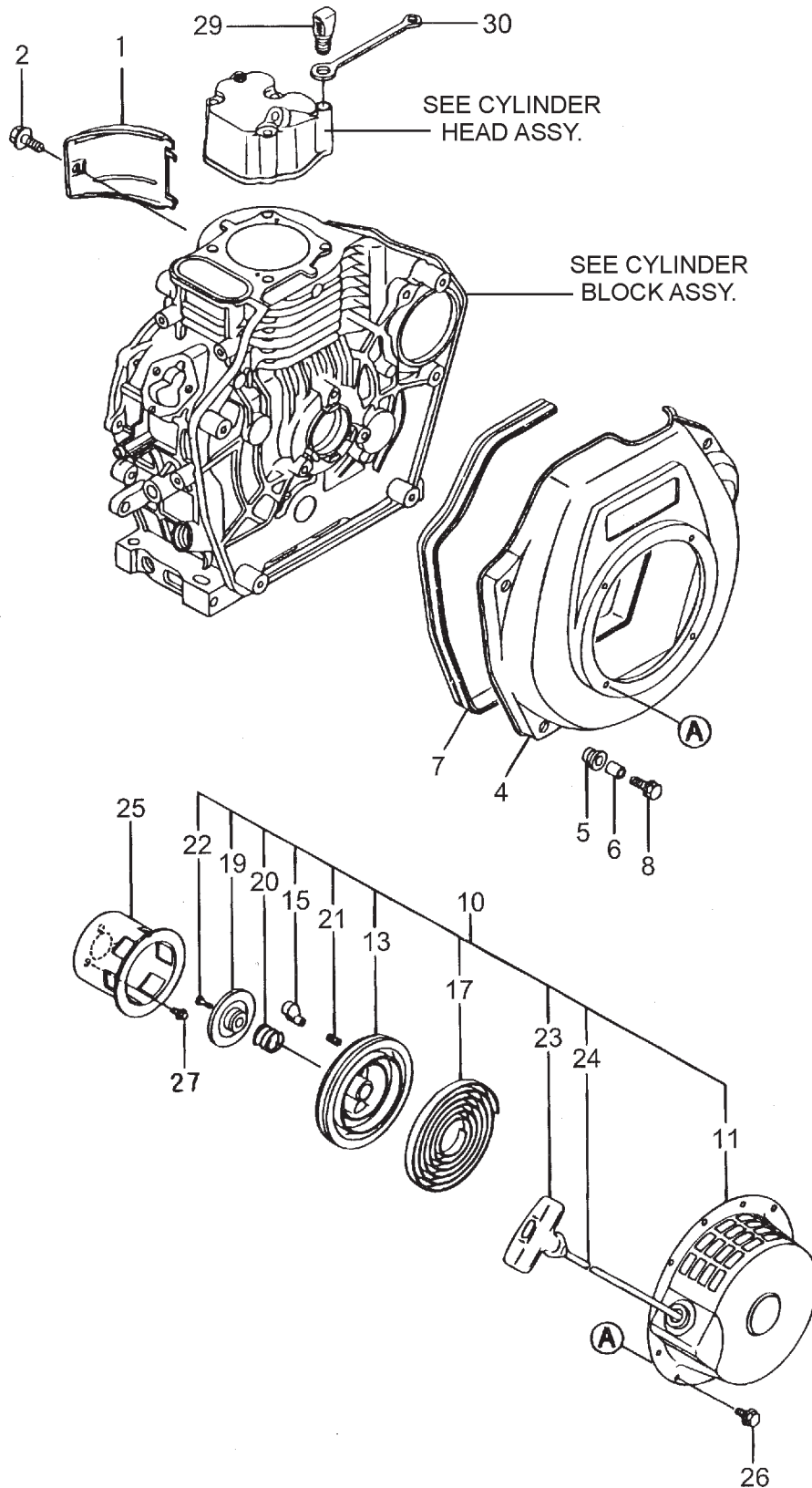

## COOLING AND STARTING DEVICE ASSY.

<u>NO.</u>	<u>PART NO.</u>	<u>PART NAME</u>	<u>QTY.</u>	<u>REMARKS</u>
1	11429945210	CYLINDER COVER	1	
2	26106060122	BOLT M 6X12 PLATED	1	
4	11429545100	COOLING FAN CASE	1	
5	11429945300	CUSHION RUBBER	4	
6	11429945310	FAN CASE COLLAR	4	
7	11429945330	FAN CASE SEAL	1	
8	11429945350	FAN CASE BOLT	4	
10	11429976250	RECOIL STARTER (D) ASSY. ....	1	INCLUDES ITEMS W/*
11*	11429976500	STARTER CASE	1	
13*	11429976520	REEL	1	
15*	11439976530	RATCHET	1	
17*	11439976540	SPIRAL SPRING	1	
19*	11439975550	RATCHET COVER	1	
20*	11439976560	SPRING	1	
21*	11439976570	RETURN SPRING	1	
22*	11439976580	SCREW	1	
23*	11439976620	STARTER KNOB	1	
24*	11429976630	STARTER ROPE	1	
25	11429976590	STARTER PULLEY	1	
26	26106060082	BOLT M 6X 8 PLATED	4	
27	26106060122	BOLT M6X 12 PLATED	3	
29	11429976600	PLUNGER	1	
30	11429976610	PLUNGER HOLDER	1	

# FUEL INJECTION PUMP ASSY.

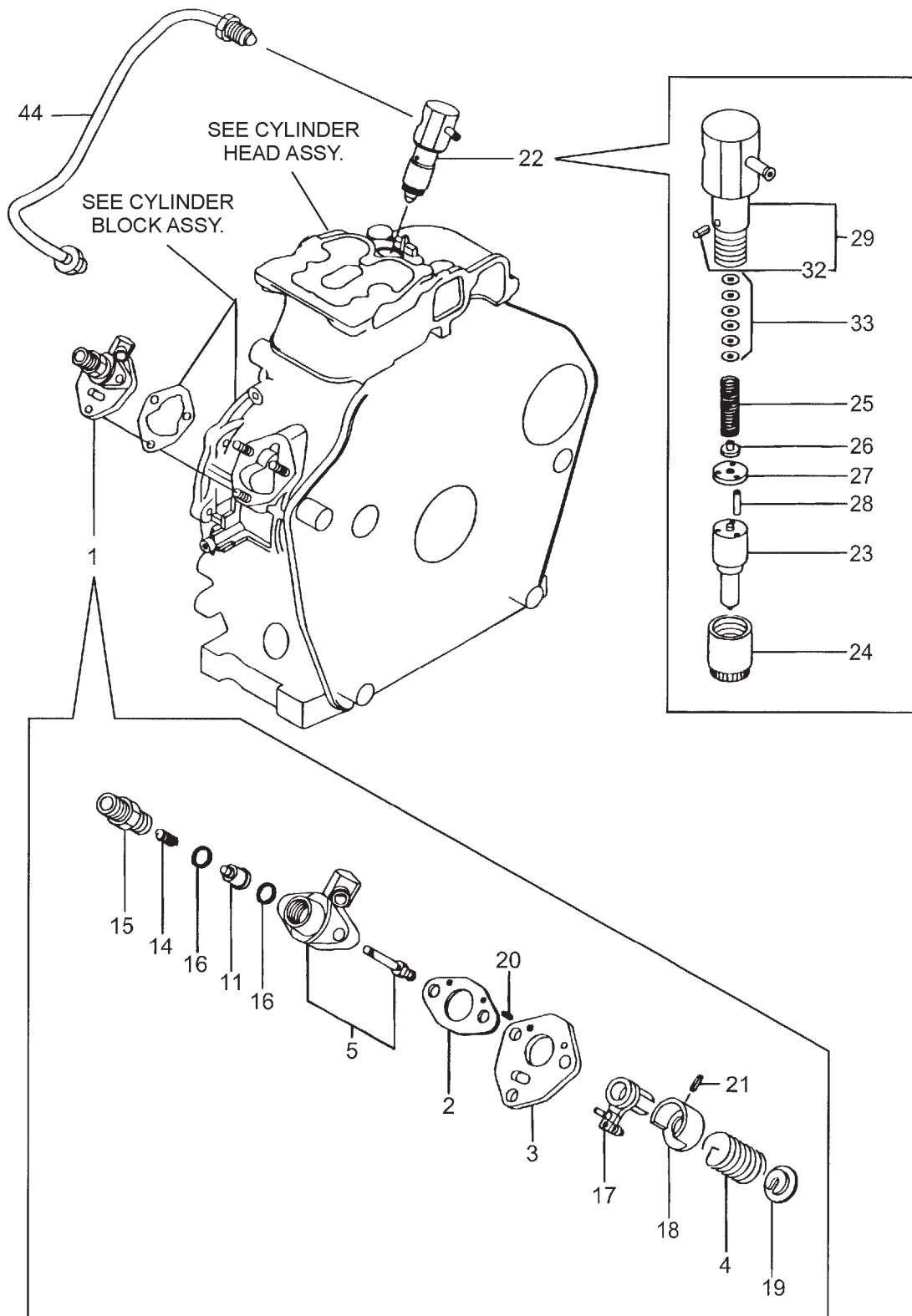



## FUEL INJECTION PUMP ASSY.

<u>NO.</u>	<u>PART NO.</u>	<u>PART NAME</u>	<u>QTY.</u>	<u>REMARKS</u>
1	71477551100	INJECTION PUMP ASSY., F .....	1 .....	INCLUDES ITEMS W/*
2*	10554651020	GASKET	1	
3*	11425051080	PLATE	1	
4*	11425051160	SPRING	1	
5*	11435051200	FUEL INJECTION PUMP BODY	1	
11*	11425051300	VALVE ASSY. DELIVERY	1	
14*	10554651330	DELIVERY VALVE SPRING	1	
15*	11425051340	F.I.P. DELIVERY HOLDER	1	
16*	12455051350	DELIVERY GASKET	2	
17*	11425051600	CONTROL LEVER ASSY.	1	
18*	11425051640	SPRING SEAT ( A)	1	
19*	11425051650	SPRING SEAT (B)	1	
20*	22351020006	SPRING PIN 2X 6	2	
21*	22351030008	SPRING PIN 3X 8	1	
22	71477553101	FUEL INJECTION VALVE ASSY. ....	1 .....	INCLUDES ITEMS W/ #
23 #	11477153001	FUEL INJECTION NOZZLE ASSY.	1	
24 #	11959353080	NOZZLE CASE NUT	1	
25 #	11425053120	NOZZLE SPRING	1	
26 #	11959353130	SPRING RETAINER	1	
27 #	11477553140	VALVE STOP SPACER	1	
28 #	11477553210	PIN	2	
29 #	11477553100	HOLDER ASSY. ....	1 .....	INCLUDES ITEMS W/ %
32 #%	11477553330	PIN	1	
33 #	11425053400	SHIM PACK	1	
44	11477159803	FUEL INJECTION PIPE	1	

# FUEL TANK AND FUEL LINE ASSY.

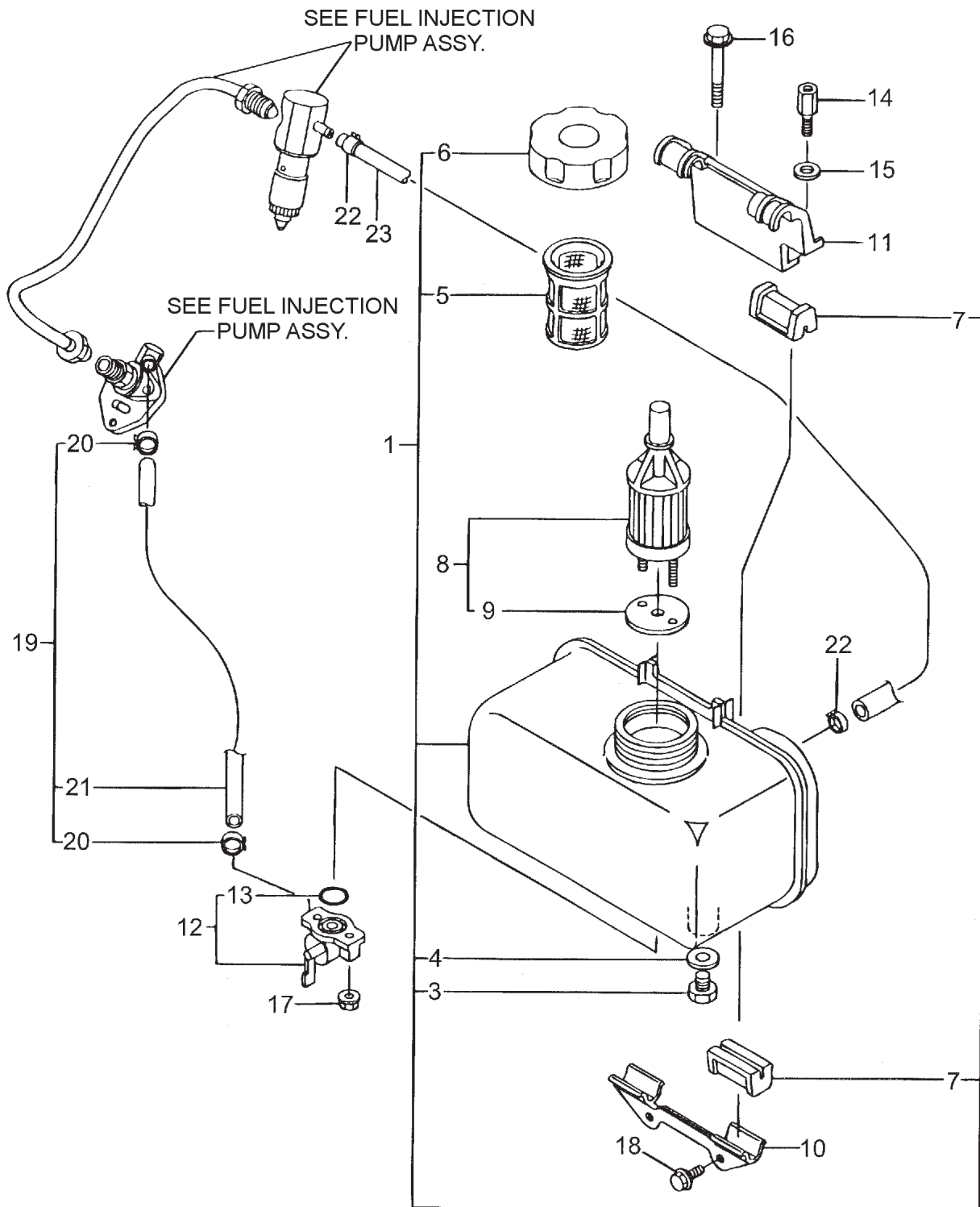

## FUEL TANK AND FUEL LINE ASSY.

<u>NO.</u>	<u>PART NO.</u>	<u>PART NAME</u>	<u>QTY.</u>	<u>REMARKS</u>
1	71429955720	FUEL TANK, BLACK .....	1 .....	INCLUDES ITEMS W/ #
3#	10530055080	DRAIN PLUG	1	
4#	23414080000	ROUND GASKET 8	1	
5#	11429955100	FILTER, FUEL OIL	1	
6#	11429955040	FUEL TANK CAP ASSY.	1	
7#	11429955201	FUEL TANK DAMPER	4	
8	11425055121	FILTER, FUEL STRAINER .....	1 .....	INCLUDES ITEM W/ %
9%	11425055130	GASKET	1	
10#	11429955210	STAY	1	
11	11429955230	STAY (B)	1	
12	11425055301	COCK .....	1 .....	INCLUDES ITEM W/+
13+	24341000150	O- RING 1A S- 15.0	1	
14	11429955810	LIFTING BOLT	1	
15	22117080000	WASHER 8	1	
16	26106080452	BOLT M 8X 45 PLATED	1	
17	26368060002	NUT M6	2	
18	26106060162	BOLT M6X 16 PLATED	2	
19	11477059030	FUEL OIL PIPE ASSY. ....	1 .....	INCLUDES ITEMS W/*
20*	11427059010	HOSE CLIP	2	
21*	11426859061	FUEL OIL PIPE	1	
22	12472259050	CLAMP 9	2	
23	11425059060	FUEL RETURN PIPE	1	

# TOOLS, LABELS AND GASKET SET ASSY.

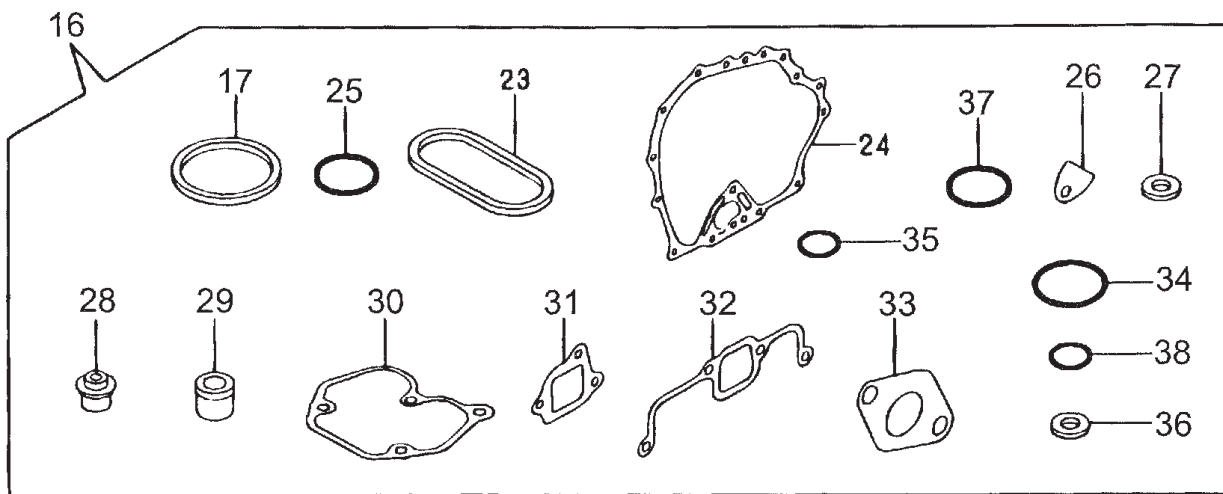
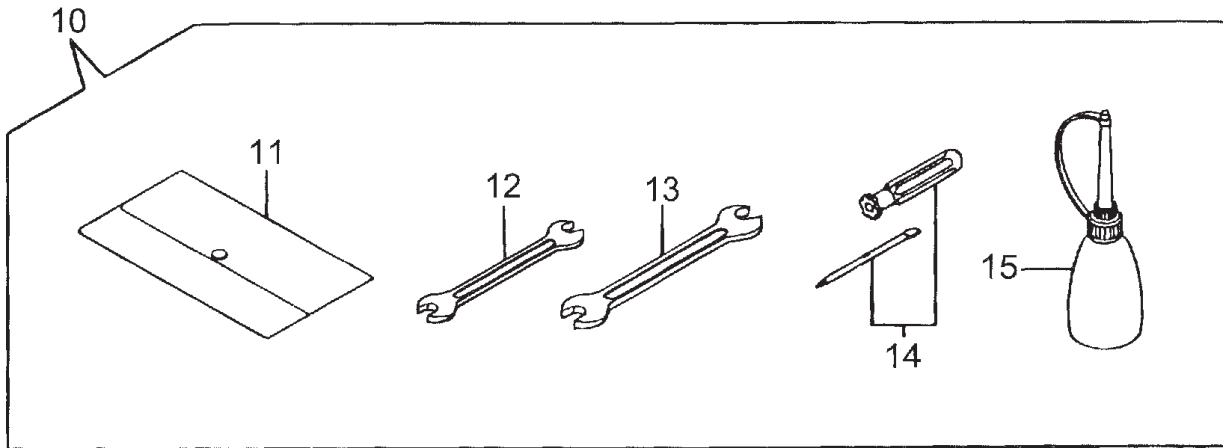
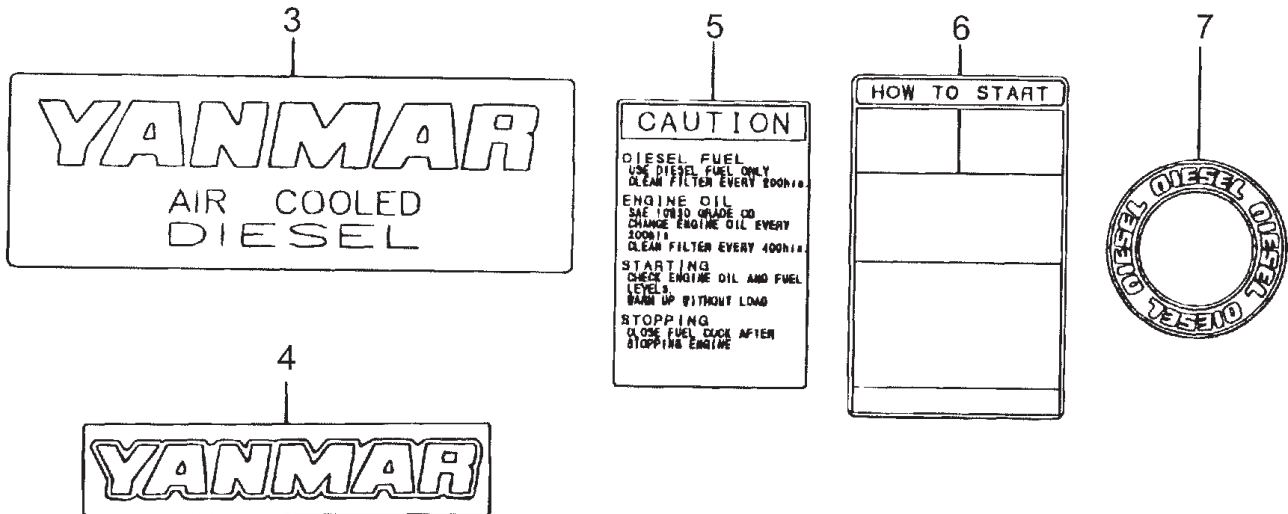

## TOOLS, LABELS AND GASKET SET ASSY.

<u>NO.</u>	<u>PART NO.</u>	<u>PART NAME</u>	<u>QTY.</u>	<u>REMARKS</u>
3	11429907100	AIR COOLED LABEL	1	
4	11429907110	YANMAR LABEL	1	
5	11421007120	CAUTION LABEL	1	
6	11421007130	HOW TO START -E LABEL	1	
7	11429907160	DIESEL LABEL	1	
10	11429992590	TOOL ASSY.....	1	INCLUDES ITEMS W/*
11*	11429992600	TOOL BAG	1	
12*	11429992710	SPANNA	1	
13*	11429992720	SPANNA	1	
14*	11429992730	DRIVER	1	
15*	11429992740	FUEL FITTING	1	
16	71411092600	GASKET SET .....	1	INCLUDES ITEMS W/#
17#	11429501330	CYLINDER HEAD GASKET ASSY.	1	
23#	11429901280	O- RING	1	
24#	11429901410	CRANK CASE GASKET	1	
25#	11429901950	O- RING	2	
26#	11425001841	GASKET	1	
27#	22190160002	WASHER SEAL 16S	2	
28#	11425011340	VALVE STEM SEAL	2	
29#	11477111461	NOZZLE GASKET	1	
30#	11477111310	BONNET GASKET	1	
31#	11429912210	AIR CLEANER GASKET	1	
32#	11477112200	AIR INTAKE GASKET	1	
33#	11429913200	MUFFLER GASKET	1	
34#	11429932570	O- RING, COVER	1	
35#	24341000100	O- RING 1A S-10.0	1	
36#	23414080000	PACKING 8	1	
37#	24341000224	O- RING 1A S- 22.4	1	
38#	24341000150	O- RING 1A S- 15.0	1	

# TERMS AND CONDITIONS OF SALE — PARTS

## PAYMENT TERMS

Terms of payment for parts are net 30 days.

## FREIGHT POLICY

All parts orders will be shipped collect or prepaid with the charges added to the invoice. All shipments are F.O.B. point of origin. Multiquip's responsibility ceases when a signed manifest has been obtained from the carrier, and any claim for shortage or damage must be settled between the consignee and the carrier.

## MINIMUM ORDER

The minimum charge for orders from Multiquip is \$15.00 net. Customers will be asked for instructions regarding handling of orders not meeting this requirement.

## RETURNED GOODS POLICY

Return shipments will be accepted and credit will be allowed, subject to the following provisions:

1. A Returned Material Authorization must be approved by Multiquip prior to shipment.
2. To obtain a Return Material Authorization, a list must be provided to Multiquip Parts Sales that defines item numbers, quantities, and descriptions of the items to be returned.
  - a. The parts numbers and descriptions must match the current parts price list.
  - b. The list must be typed or computer generated.
  - c. The list must state the reason(s) for the return.
  - d. The list must reference the sales order(s) or invoice(s) under which the items were originally purchased.
  - e. The list must include the name and phone number of the person requesting the RMA.
3. A copy of the Return Material Authorization must accompany the return shipment.
4. Freight is at the sender's expense. All parts must be returned freight prepaid to Multiquip's designated receiving point.

5. Parts must be in new and resalable condition, in the original Multiquip package (if any), and with Multiquip part numbers clearly marked.
6. The following items are not returnable:
  - a. Obsolete parts. (If an item is in the price book and shows as being replaced by another item, it is obsolete.)
  - b. Any parts with a limited shelf life (such as gaskets, seals, "O" rings, and other rubber parts) that were purchased more than six months prior to the return date.
  - c. Any line item with an extended dealer net price of less than \$5.00.
  - d. Special order items.
  - e. Electrical components.
  - f. Paint, chemicals, and lubricants.
  - g. Decals and paper products.
  - h. Items purchased in kits.
7. The sender will be notified of any material received that is not acceptable.
8. Such material will be held for five working days from notification, pending instructions. If a reply is not received within five days, the material will be returned to the sender at his expense.
9. Credit on returned parts will be issued at dealer net price at time of the original purchase, less a 15% restocking charge.
10. In cases where an item is accepted, for which the original purchase document can not be determined, the price will be based on the list price that was effective twelve months prior to the RMA date.
11. Credit issued will be applied to future purchases only.

## PRICING AND REBATES

Prices are subject to change without prior notice. Price changes are effective on a specific date and all orders received on or after that date will be billed at the revised price. Rebates for price declines and added charges for price increases will not be made for stock on hand at the time of any price change.

Multiquip reserves the right to quote and sell direct to Government agencies, and to Original Equipment Manufacturer accounts who use our products as integral parts of their own products.

## SPECIAL EXPEDITING SERVICE

A \$35.00 surcharge will be added to the invoice for special handling including bus shipments, insured parcel post or in cases where Multiquip must personally deliver the parts to the carrier.

## LIMITATIONS OF SELLER'S LIABILITY

Multiquip shall not be liable hereunder for damages in excess of the purchase price of the item with respect to which damages are claimed, and in no event shall Multiquip be liable for loss of profit or good will or for any other special, consequential or incidental damages.

## LIMITATION OF WARRANTIES

No warranties, express or implied, are made in connection with the sale of parts or trade accessories nor as to any engine not manufactured by Multiquip. Such warranties made in connection with the sale of new, complete units are made exclusively by a statement of warranty packaged with such units, and Multiquip neither assumes nor authorizes any person to assume for it any other obligation or liability whatever in connection with the sale of its products. Apart from such written statement of warranty, there are no warranties, express, implied or statutory, which extend beyond the description of the products on the face hereof.

Effective: February 22, 2006



# OPERATION AND PARTS MANUAL

## HERE'S HOW TO GET HELP

PLEASE HAVE THE MODEL AND SERIAL  
NUMBER ON-HAND WHEN CALLING

### UNITED STATES

#### ***Multiquip Corporate Office***

18910 Wilmington Ave. Tel. (800) 421-1244  
Carson, CA 90746 Fax (800) 537-3927  
Contact: mq@multiquip.com

#### ***Service Department***

800-421-1244 Fax: 310-537-4259  
310-537-3700

#### ***Technical Assistance***

800-478-1244 Fax: 310-943-2238

#### ***MQ Parts Department***

800-427-1244 Fax: 800-672-7877  
310-537-3700 Fax: 310-637-3284

#### ***Warranty Department***

800-421-1244 Fax: 310-537-1173  
310-537-3700

### MEXICO

#### ***MQ Cipsa***

Carr. Fed. Mexico-Puebla KM 126.5 Tel: (52) 222-225-9900  
Momoxpan, Cholula, Puebla 72760 Mexico Fax: (52) 222-285-0420  
Contact: pmastretta@cipsa.com.mx

### CANADA

#### ***Multiquip***

4110 Industriel Boul. Tel: (450) 625-2244  
Laval, Quebec, Canada H7L 6V3 Tel: (877) 963-4411  
Contact: jmartin@multiquip.com Fax: (450) 625-8664

### UNITED KINGDOM

#### ***Multiquip (UK) Limited Head Office***

Unit 2, Northpoint Industrial Estate, Tel: 0161 339 2223  
Globe Lane, Fax: 0161 339 3226  
Dukinfield, Cheshire SK16 4UJ  
Contact: sales@multiquip.co.uk

© COPYRIGHT 2011, MULTIQUIP INC.

Multiquip Inc, the MQ logo and the Mikasa logo are registered trademarks of Multiquip Inc. and may not be used, reproduced, or altered without written permission. All other trademarks are the property of their respective owners and used with permission.

This manual MUST accompany the equipment at all times. This manual is considered a permanent part of the equipment and should remain with the unit if resold.

The information and specifications included in this publication were in effect at the time of approval for printing. Illustrations, descriptions, references and technical data contained in this manual are for guidance only and may not be considered as binding. Multiquip Inc. reserves the right to discontinue or change specifications, design or the information published in this publication at any time without notice and without incurring any obligations.

Your Local Dealer is:





## Free Manuals Download Website

<http://myh66.com>

<http://usermanuals.us>

<http://www.somanuals.com>

<http://www.4manuals.cc>

<http://www.manual-lib.com>

<http://www.404manual.com>

<http://www.luxmanual.com>

<http://aubethermostatmanual.com>

Golf course search by state

<http://golfingnear.com>

Email search by domain

<http://emailbydomain.com>

Auto manuals search

<http://auto.somanuals.com>

TV manuals search

<http://tv.somanuals.com>