

# OPERATION AND PARTS MANUAL



*Mikasa* **SERIES**  
**MODEL MT-74FA**  
**TAMPING RAMMER**  
**(ROBIN GASOLINE ENGINE)**

Revision #3 (11/08/07)

To find the latest revision of this  
publication, visit our website at:  
[www.multiquip.com](http://www.multiquip.com)



**THIS MANUAL MUST ACCOMPANY THE EQUIPMENT AT ALL TIMES.**



**WARNING**



**CALIFORNIA — Proposition 65 Warning**

Engine exhaust and some of its constituents are known to the State of California to cause cancer, birth defects and other reproductive harm.



## Multiquip Tamping Rammer MT-74FA

Proposition 65 Warning .....	2
Table Of Contents .....	4
Parts Ordering Procedures .....	5
Safety Message Alert Symbols .....	6-7
Rules For Safe Operation .....	8-9
Operation and Safety Decals .....	10
General Information .....	11
Specifications .....	12
Controls and Components .....	13
Operation .....	14-16
Maintenance .....	17
Troubleshooting Guide .....	18-19
Explanation Of Codes In Remarks Column .....	20
Suggested Spare Parts .....	21
Name Plate and Decals .....	22-23
Crankcase and Engine Assembly .....	24-27
Guide Cylinder and Foot Assembly .....	28-29
Tank and Handle Assembly .....	30-33

## ROBIN EH-12-2D46420 ENGINE

Crankcase and Cylinder Assembly .....	34-35
Crankshaft and Piston Assembly .....	36-37
Muffler, Air Cleaner, Camshaft, & Carb. Assy. .	38-39
Governor Assembly .....	40-41
Recoil Starter and Blower Assembly .....	42-43
Magneto Assembly .....	44-45
Carburetor Assembly .....	46-47

Terms and Condition Of Sale — Parts .....	48
---	----

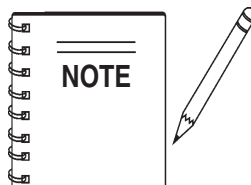

*Specification and part number are subject to change without notice.*



## Ordering parts has never been easier! Choose from three easy options:

Effective:  
January 1<sup>st</sup>, 2006



### Order via Internet (Dealers Only):

Order parts on-line using Multiquip's SmartEquip website!

- View Parts Diagrams
- Order Parts
- Print Specification Information



If you have an MQ Account, to obtain a Username and Password, E-mail us at: [parts@multiquip.com](mailto:parts@multiquip.com).

To obtain an MQ Account, contact your District Sales Manager for more information.

Goto [www.multiquip.com](http://www.multiquip.com) and click on **Order Parts** to log in and save!

Use the **internet** and qualify for a **5% Discount** on *Standard orders* for all orders which include complete part numbers.\*

Note: Discounts Are Subject To Change



### Order via Fax (Dealers Only):

All customers are welcome to order parts via Fax.

**Domestic (US) Customers dial:**  
1-800-6-PARTS-7 (800-672-7877)

**Fax** your order in and qualify for a **2% Discount** on *Standard orders* for all orders which include complete part numbers.\*

Note: Discounts Are Subject To Change



**Order via Phone: Domestic (US) Dealers Call:**  
1-800-427-1244

### Non-Dealer Customers:

Contact your local Multiquip Dealer for parts or call 800-427-1244 for help in locating a dealer near you.



**International Customers** should contact their local Multiquip Representatives for Parts Ordering information.

## When ordering parts, please supply:

- |  |  |
|--|--|
| <ul style="list-style-type: none"> <li><input type="checkbox"/> Dealer Account Number</li> <li><input type="checkbox"/> Dealer Name and Address</li> <li><input type="checkbox"/> Shipping Address (if different than billing address)</li> <li><input type="checkbox"/> Return Fax Number</li> <li><input type="checkbox"/> Applicable Model Number</li> <li><input type="checkbox"/> Quantity, Part Number and Description of Each Part</li> </ul> | <ul style="list-style-type: none"> <li><input type="checkbox"/> Specify Preferred Method of Shipment:                     <ul style="list-style-type: none"> <li><input checked="" type="checkbox"/> UPS/Fed Ex      <input checked="" type="checkbox"/> DHL</li> <li><input type="checkbox"/> Priority One      <input checked="" type="checkbox"/> Truck</li> <li><input type="checkbox"/> Ground</li> <li><input type="checkbox"/> Next Day</li> <li><input type="checkbox"/> Second/Third Day</li> </ul> </li> </ul> |
|--|--|

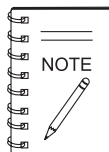

All orders are treated as *Standard Orders* and will ship the same day if received prior to 3PM PST.

WE ACCEPT ALL MAJOR CREDIT CARDS!



# MT-74FA — SAFETY MESSAGE ALERT SYMBOLS

## FOR YOUR SAFETY AND THE SAFETY OF OTHERS!

Safety precautions should be followed at all times when operating this equipment. Failure to read and understand the Safety Messages and Operating Instructions could result in injury to yourself and others.

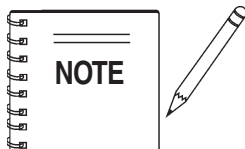

This Owner's Manual has been developed to provide complete instructions for the safe and efficient operation of the **MQ Mikasa Model MT-74FA Tamping Rammer**. Refer to the engine manufacturers instructions for data relative to its safe operation.

**Before using this rammer, ensure that the operating individual has read and understands all instructions in this manual.**

## SAFETY MESSAGE ALERT SYMBOLS

The three (3) Safety Messages shown below will inform you about potential hazards that could injure you or others. The Safety Messages specifically address the level of exposure to the operator, and are preceded by one of three words: **DANGER**,

### **DANGER**

You **WILL** be **KILLED** or **SERIOUSLY INJURED** if you **DO NOT** follow these directions.

### **WARNING**

You **CAN** be **KILLED** or **SERIOUSLY INJURED** if you **DO NOT** follow these directions.

### **CAUTION**

You **CAN** be **INJURED** if you **DO NOT** follow these directions.

## HAZARD SYMBOLS

Potential hazards associated with the operation of a **MT-74FA Tamping Rammer** will be referenced with Hazard Symbols which appear throughout this manual, and will be referenced in conjunction with Safety Message Alert Symbols.

### **WARNING** Lethal Exhaust Gas Hazards

Engine exhaust gases contain poisonous carbon monoxide. This gas is colorless and odorless, and can cause death if inhaled. **NEVER** operate this equipment in a confined area or enclosed structure that does not provide ample free flow air.



### **WARNING** Explosive Fuel Hazards

**Gasoline** is extremely flammable, and its vapors can cause an explosion if ignited. **DO NOT** start the engine near spilled fuel or combustible fluids.



**DO NOT** fill the fuel tank while the engine is running or hot. **DO NOT** overfill tank, since spilled fuel could ignite if it comes into contact with hot engine parts or sparks from the ignition system. Store fuel in approved containers, in well-ventilated areas and away from sparks and flames.

### **WARNING** Burn Hazards

Engine components can generate extreme heat. To prevent burns, **DO NOT** touch these areas while the engine is running or immediately after operations. Never operate the engine with heat shields or heat guards removed.



### **WARNING** Respiratory Hazards

**ALWAYS** wear approved **respiratory** protection when required.



# MT-74FA — SAFETY MESSAGE ALERT SYMBOLS

## CAUTION

### Rotating Parts Hazards

**NEVER** operate equipment with covers, or guards removed. Keep fingers, hands, hair and clothing away from all moving parts to prevent injury.



## CAUTION

### Equipment Damage Hazards

Other important messages are provided throughout this manual to help prevent damage to your light tower, other property, or the surrounding environment.

## CAUTION

### Accidental Starting Hazards

**ALWAYS** place the ON/OFF switch in the **OFF** position when the rammer is not in use.



## CAUTION

### Eye and Hearing Hazards



**ALWAYS** wear approved eye and hearing protection.

## DANGER

### Refueling Hazard

**NEVER** refuel rammer when placed in truck bed with plastic liner. The possibility exists of explosion due to static electricity. When adding fuel, remove rammer from truck bed and place on ground.

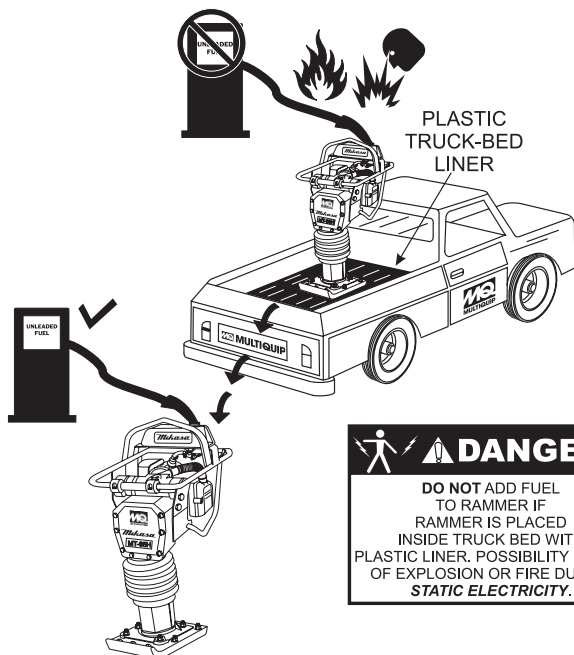

## DANGER

**DO NOT ADD FUEL TO RAMMER IF RAMMER IS PLACED INSIDE TRUCK BED WITH PLASTIC LINER. POSSIBILITY EXISTS OF EXPLOSION OR FIRE DUE TO STATIC ELECTRICITY.**

 **WARNING**



**To avoid injury, you MUST read and understand operator's manual before using this machine.**

**This machine to be operated by qualified personnel only. Ask for training as needed.**

# MT-74FA — RULES FOR SAFE OPERATION

## DANGER

Read this manual!

Failure to follow instructions in this manual may lead to serious injury or even death! This equipment is to be operated by trained and qualified personnel only! This equipment is for industrial use only.

The following safety guidelines should always be used when operating the MT-74FA Tamping Rammer:

### GENERAL SAFETY

■ **DO NOT** operate or service this equipment before reading this entire manual.



■ This equipment should not be operated by persons under 18 years of age.

■ **NEVER** operate this equipment without proper protective clothing, shatterproof glasses, steel-toed boots and other protective devices required by the job.



■ **NEVER** operate this equipment when not feeling well due to fatigue, illness or taking medicine.



■ **NEVER** operate this equipment under the influence of *drugs* or *alcohol*.



■ **ALWAYS** wear proper respiratory (mask), hearing and eye protection equipment when operating the rammer.



■ Whenever necessary, replace nameplate, operation and safety decals when they become difficult read.

■ Manufacturer does not assume responsibility for any accident due to equipment modifications.

■ **NEVER** use accessories or attachments, which are not recommended by Multiquip for this equipment. Damage to the equipment and/or injury to user may result.

■ **NEVER** touch the hot exhaust manifold, muffler or cylinder. Allow these parts to cool before servicing engine or rammer.



■ **High Temperatures** – Allow the engine to cool before adding fuel or performing service and maintenance functions. Contact with *hot!* components can cause serious burns.

■ The engine section of this rammer requires an adequate free flow of cooling air. **NEVER** operate the rammer in any enclosed or narrow area where free flow of the air is restricted. If the air flow is restricted it will cause serious damage to the rammer or engine and may cause injury to people. Remember the rammer's engine gives off **DEADLY** carbon monoxide gas.

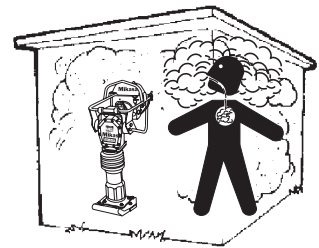

■ **ALWAYS** refuel in a well-ventilated area, away from sparks and open flames.

■ **ALWAYS** use extreme caution when working with **flammable** liquids. When refueling, **stop the engine** and allow it to cool. **DO NOT smoke** around or near the machine. Fire or explosion could result from fuel vapors, or if fuel is spilled on a hot engine.

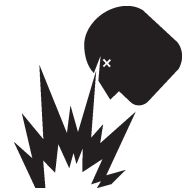

■ **NEVER** operate the rammer in an explosive atmosphere or near combustible materials. An explosion or fire could result causing severe **bodily harm or even death**.

■ **DO NOT smoke** around or near the machine. Fire or explosion could result from fuel vapors, or if fuel is spilled on a hot engine.



■ Topping-off to filler port is dangerous, as it tends to spill fuel.

■ Stop the engine when leaving the rammer unattended.

■ Maintain this equipment in a safe operating condition at all times.



# MT-74FA — RULES FOR SAFE OPERATION

- **ALWAYS** stop the engine before servicing, adding fuel and oil.
- **NEVER** run engine without air filter. Severe engine may occur.
- **ALWAYS** service air cleaner frequently to prevent carburetor malfunction.
- **ALWAYS** check the machine for loosened threads or bolts before starting.
- **ALWAYS** be sure the operator is familiar with proper safety precautions and operations techniques before using rammer.
- **ALWAYS** store equipment properly when it is not being used. Equipment should be stored in a clean, dry location out of the reach of children.
- **DO NOT** operate this equipment unless all guards and safety devices are attached and in place.
- **CAUTION** must be exercised while servicing this equipment. Rotating and moving parts can cause injury if contacted.
- Keep all ***inexperienced*** and ***unauthorized*** people away from the equipment at all times.
- Unauthorized equipment modifications will void all warranties.
- **NEVER** pour or spray water over the engine.
- Test the engine **ON/OFF** switch before operating. The purpose of this switch is to shut down the engine of the rammer.
- Refer to the ***ROBIN Engine Owner's Manual*** for engine technical questions or information recommended by Multiquip for this equipment.

## TRANSPORTING

- **ALWAYS** shutdown engine before transporting.
- Tighten fuel tank cap securely and close fuel cock to prevent fuel from spilling.
- Drain fuel when transporting rammer over long distances or bad roads.
- When placing the rammer inside a truck-bed for transport, always tie-down the rammer

## MAINTENANCE

- **NEVER** lubricate components or attempt service on a running rammer.
- **ALWAYS** allow the rammer a proper amount of time to cool before servicing.
- Keep the rammer in proper running condition.
- Fix damage to the rammer immediately and always replace broken parts.
- Dispose of hazardous waste properly. Examples of potentially hazardous waste are used motor oil, fuel and fuel filters.
- **DO NOT** use food or plastic containers to dispose of hazardous waste.

## EMERGENCIES

- **ALWAYS** know the location of the nearest ***fire extinguisher*** and ***first aid kit***.



- In emergencies ***always*** know the location of the nearest phone or ***keep a phone on the job site***. Also know the phone numbers of the nearest ***ambulance, doctor*** and ***fire department***. This information will be invaluable in the case of an emergency.



# MT-74FA — OPERATION AND SAFETY DECALS

## Machine Safety Decals

The MQ Mikasa tamping rammer is equipped with a number of safety decals. These decals are provided for operator safety and maintenance information. Figure 1 and 1A below and preceeding page illustrates these decals as they appear on the machine. Should any of these decals become unreadable, replacements can be obtained from your dealer.



P/N 0732004450



P/N 920108310



P/N 920210170

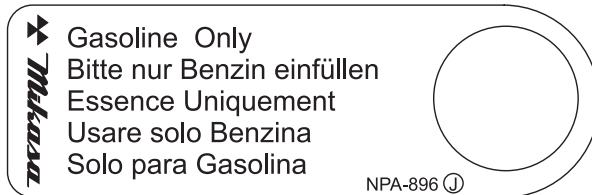

P/N 920208960



P/N 920210180

3400 ~ 3600 RPM

P/N 920206020

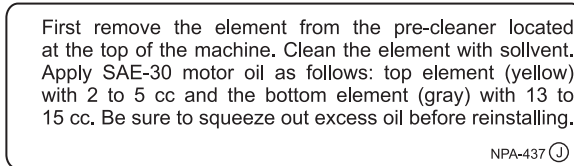

P/N 920204370

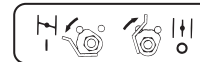

P/N 0732005020

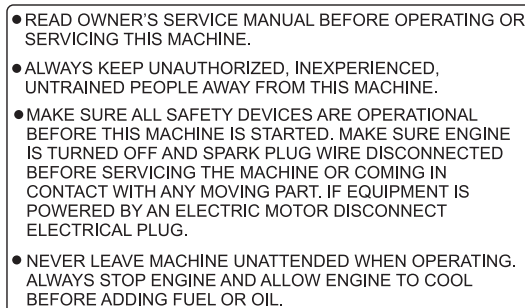

P/N 920203290



P/N 0732004520

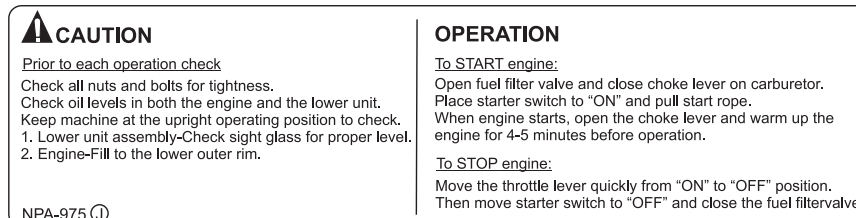

P/N 920209750

Figure 1. Rammer Operation and Safety Decals

# MT-74FA — OPERATION AND SAFETY DECALS

**SECONDARY AIRFILTER  
SERVICE MONTHLY**

NPA1016 ©

P/N 920210160

To start, switch must be  
in the "ON" position

NPA 293

P/N 920202930

When you stop  
the engine, be  
sure to close  
the fuel cock.

NPA-399 Ⓟ

P/N 920203990

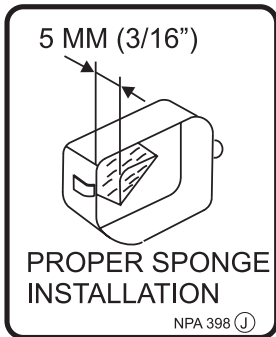

P/N 920203980



P/N 920100240



P/N 920203330

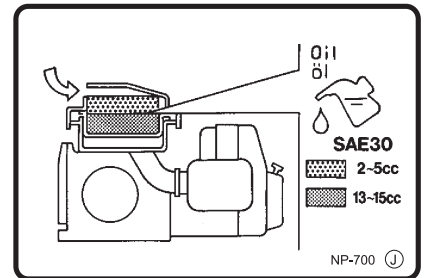

P/N 920107000



P/N 920209100

⚠ CAUTION  
⚠ ATTENZIONE  
⚠ ATENÇÃO  
⚠ PRECAUCION

\* Read operator's manual carefully before use.  
\* Libre le manual attentivement avant utilisation.  
\* Bitte lesen Sie vor inbetriebnahme der Maschine de  
Bedienungsanleitung sorgfältig durch.  
\* Prima dell' uso leggere attentamente il manuale.  
\* Lee com atenção o manual de instruções antes de  
usar.  
\* Leer detenidamente el manual de instrucciones  
antes de usar la maquina.

NPA-769 Ⓟ

P/N 920207690

**⚠ WARNING**

- ★ READ ENGINE STARTING AND OPERATING GUIDE CAREFULLY BEFORE STARTING ENGINE.
- SHUT OFF ENGINE BEFORE REFUELING. THOROUGHLY WIPE SPILLED FUEL BEFORE STARTING.
- CHECK FOR LEAKAGE FROM HOSES AND FITTINGS
- KEEP FLAMMABLES AWAY FROM ENGINE.
- SHUT OFF FUEL VALVE WHEN ENGINE IS NOT IN USE.
- OPERATE ENGINE IN A WELL VENTILATED AREA. DO NOT OPERATE IN A CLOSED ROOM.
- DO NOT TOUCH MUFFLER OR ANY AREA NEAR EXHAUST DURING OPERATION.

P/N 0732003900

**Mikasa**

Serial No.

Model No.

**MQ MULTQUIP**



P/N 920106460

**CONTACT  
MQ PARTS DEPT.**

Figure 1A. Rammer Operation and Safety Decals

## Definition of Tamping Rammer

The Mikasa MT-74FA tamping rammer is a powerful compacting tool capable of applying a tremendous force in consecutive impacts to a soil surface. Its applications include soil compacting for road, embankments and reservoirs as well as backfilling for gas pipelines, water pipelines and cable installation work.

The impact force of the MT-74FA levels and uniformly compacts voids between soil particles to increase dry density.

Circular motion is converted to create impact force. The MT-74FA tamping rammer develops a powerful compacting force at the foot of the rammer. To maintain optimum performance, proper operation and service are essential.

## Construction of Tamping Rammer

The Mikasa MT-74FA is equipped with an air-cooled, 4-cycle gasoline engine. Transmission of the power takes place by increasing the engine speed to engage the centrifugal clutch.

## Rammer Gearbox and Spring Cylinder

The Mikasa MT-74FA uses an oil bath lubrication system. Always check the oil level through the oil level sight glass at the rear of the tamper foot.

## Controls

Before starting the MT-74FA Tamping Rammer, identify and understand the function of the controls. See Figure 2.

## CAUTION

### Handle Operation



Before starting operation check the lifting handle to:

1. Make sure that there is no damage on the bolts.
2. Make sure that there is no crack or breakage on handle.
3. Make sure that there is no fissure on the surface. If there is any abnormality or damage, replace with new one.

For operation:

This handle is to be used to lift up the shoe part of the machine with the body laid down on the ground or truck bed.

1. Use proper lifting techniques to avoid back injury. This handle is for manual lifting only.
2. Do not use this handle as a rammer lift point. Use the lifting point on the top of the machine.
3. Do not move the rammer with the lifting handle and the front rollers more than (16 feet) 5 meters.

## Table 1. MT-74FA Rammer Specifications

MODEL	MT-74FA
Overall Height	41.5 in (1055 mm)
Overall Width	16.1 in (410 mm)
Over Length	28.9 in (735 mm)
Shoe Size (L x W)	13.4 x 11.2 in (340 x 285 mm)
Blows/minute	640-680
Impact Force	3,100 lb (1,400 kg)
Stroke	3.15 in. (80 mm)
Travel Speed	29.5 - 39.4 ft/min (9 - 12 m/min)
Operating Weight	179 lbs (81 kg)

## Table 2. EH12-2D46420 Engine Specifications

MODEL	ROBIN EH12-2D46420
Type	Air-Cooled 4 Stroke Gasoline Engine
Piston Displacement	7.38 cu.in. (121 cm <sup>3</sup> )
Max. Output	3.5 HP (2.6 kw)
Setting Speed	3,400 - 3,600 rpm
Cooling System	Air-Cooled
Lubrication System	Oil Bath - 10W30 Motor Oil
Oil Tank Capacity	0.8 pint (0.4 liter)
Fuel	Unleaded gasoline
Fuel Tank Capacity	2.1 quart (2 liters)
Starting System	Recoil Starter
Carburetor System	Diaphragm

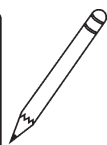
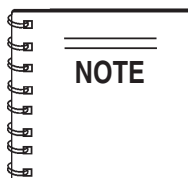

Specifications are general and are subject to change without notice. If exact measurements are required, equipment should be weighed and measured.

# MT-74FA — CONTROLS AND COMPONENTS

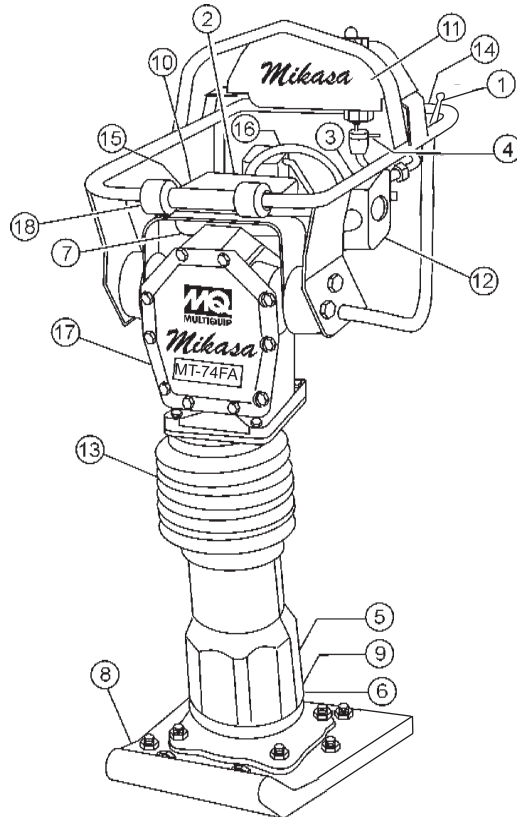

**Figure 2. MT-74FA Rammer**

Figure 2 shows the location of the controls and components for the MT-74FA Tamping Rammer. The functions of each control is described below:

1. **Throttle Lever** – Controls engine speed and the tamping action of the rammer.
2. **Engine Stop Switch** – Controls the starting and stopping of the engine. Switch must be in the "ON" position when starting the engine.
3. **Choke Lever** – Used when starting the engine. Normally used in cold weather conditions. In cold weather turn the choke lever to the fully closed position, in warm weather set choke lever half way or completely open.
4. **Fuel Shut-Off Valve** – Supplies fuel from the fuel tank to the engine. To begin fuel flow move the fuel shut-off valve downward.
5. **Oil Bath Fill Plug** – Open this plug to add oil to the oil bath reservoir.
6. **Drain Valve** – Open this valve to remove oil from the bellows.
7. **Pre-Cleaner** – Pre-cleans (first stage) dirt and other debris from entering the engine.
8. **Foot** – Laminated wood with tempered steel plate for superior shock absorption.
9. **Oil Level Sight Glass** – Indicates the level of oil in the oil bath reservoir.
10. **Recoil Starting Handle** – Used when starting the engine. Pull starter handle sharply and quickly, then return starter handle to starter case before releasing.
11. **Fuel Tank/Cap** – Poly fuel tank to avoid rust and corrosion, remove this cap to add gasoline.
12. **Engine Air Cleaner** – Prevents dirt (second stage) and other debris from entering the engine.
13. **Bellows** – Reservoir for oil bath.
14. **Handle** – To operate rammer, grip handle assembly firmly on both sides.
15. **Muffler** – Used to reduce noise and emissions.
16. **Spark Plug** – Provides spark to the ignition system, replace with engine manufactures recommended type spark plug.
17. **Nameplate** – Displays information regarding the rammer.

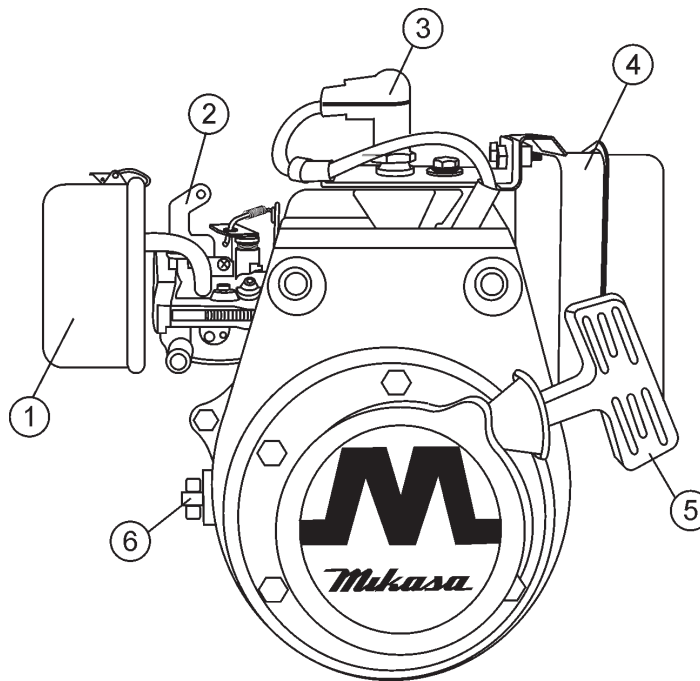

Figure 3. Robin EH-12-2D Engine Controls and Components

## INITIAL SERVICING

The engine (Figure 3) must be checked for proper lubrication and filled with fuel prior to operation. Refer to the manufacturer's Engine manual for instructions & details of operation and servicing.

1. **Secondary Air Cleaner** – Prevents dirt and other debris from entering the fuel system. Remove wing-nut on top of air filter cannister to gain access to filter element.
2. **Choke Lever** –Used when starting the engine. Normally used in cold weather conditions. In cold weather turn the choke lever to the fully closed position, in warm weather set choke lever half way or completely open.
3. **Spark Plug** – Provides spark to the ignition system. Set spark plug gap to 0.6 - 0.7 mm (0.024 - 0.028 inch). Clean spark plug once a week.
4. **Muffler** – Used to reduce noise and emissions.

5. **Recoil Starter (pull rope)** – Manual-starting method. Pull the starter grip until resistance is felt, then pull briskly and smoothly.
6. **Engine ON/OFF Switch** – Controls the starting and stopping of the engine. Switch must be in the "ON" position when starting the engine.

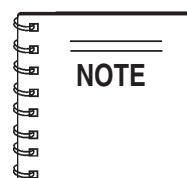

Operating the engine without an air filter, with a damaged air filter, or a filter in need of replacement will allow dirt to enter the engine, causing rapid engine wear.



### **WARNING**

Engine components can generate extreme heat. To prevent burns, **DO NOT** touch these areas while the engine is running or immediately after operating. **NEVER** operate the engine with the muffler removed.



This section is intended to assist the operator with the initial start-up of the MT-74FA Tamping Rammer. It is extremely important that this section be read carefully before attempting to operate the rammer.

**DO NOT** use your rammer until this section is thoroughly understood.



**CAUTION**

Read Manual



Failure to understand the operation of the MT-74FA Tamping Rammer could result in severe damage to the trowel or personal injury.

### Rammer Gearbox and Spring Cylinder Oil Bath

This unit uses an oil bath lubrication system. Perform the following:

1. Check the oil level through the oil level sight glass (Figure 4) at the rear of the tamper foot.

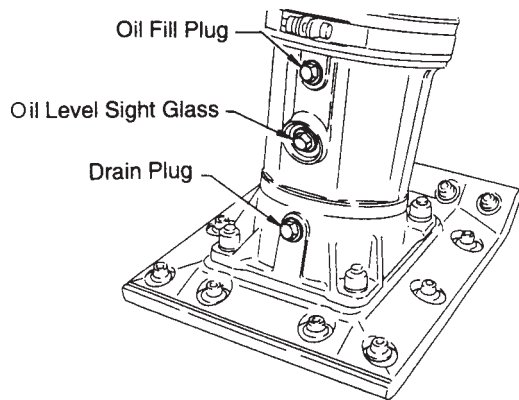

**Figure 4. Foot Housing Sight Glass**

2. If oil is not visible, add 10W-30 motor oil into the oil fill plug opening (Figure 4). The bath contains approximately 0.8 pints (0.4 liters)

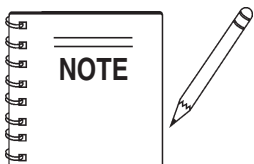

The oil level should be kept at the half way point of the sight glass.

### Engine

1. Fill the fuel tank (Figure 5) with unleaded gasoline. At the same time, check the engine oil and make it a habit to replenish it often.

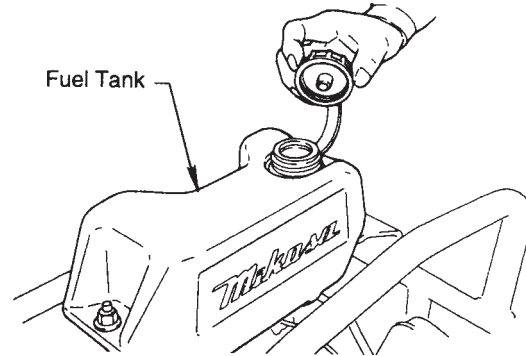

**Figure 5. Fuel Tank**

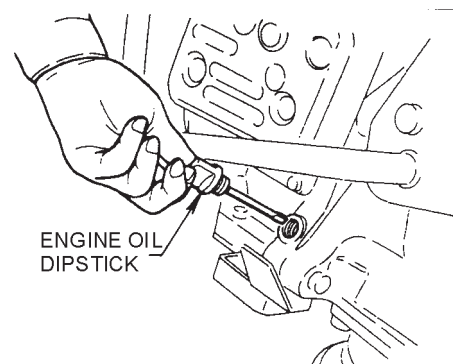

**Figure 6. Engine Oil Dipstick**

2. Low levels of oil may result in engine seizure due to high levels of consumption during operations.
3. Check the engine oil level and if the engine oil level is low, it should be refilled. Use the proper motor oil as suggested in the Table 3 below.

Season or Temperature	Grade of motor oil (higher than MS class)
Spring, Summer or Autumn +120° F to +15° F	SAE 30
Winter +40° F to +15° F	SAE 30
Below +15° F	SAE 10W-30



## Inspection

1. Check all nuts, bolts fasteners for tightness. Retighten as necessary.
2. Clean any dirt from the recoil starter and foot pedestal. Wipe the entire unit clean before operating.
3. Replace any missing or damaged Safety Operation decals.
4. Adjust height of handle. Adjust handle by loosening nuts and moving handle to suit operation. Retighten nuts.

## Initial Start-up

When starting the MT-74FA Tamping Rammer perform the following:

1. Open the fuel shut-off valve by moving the **fuel cock** lever to the **open** position (Figure 7) then set the engine start/stop switch (Figure 6) to the **"START"** position.

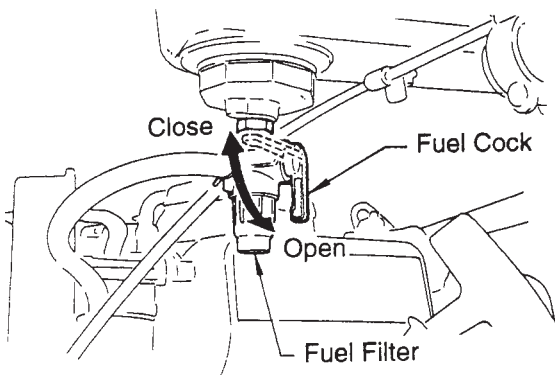

**Figure 7. Fuel Cock**

2. Set the engine ON/OFF switch (Figure 8) to the **"ON"** position (start).

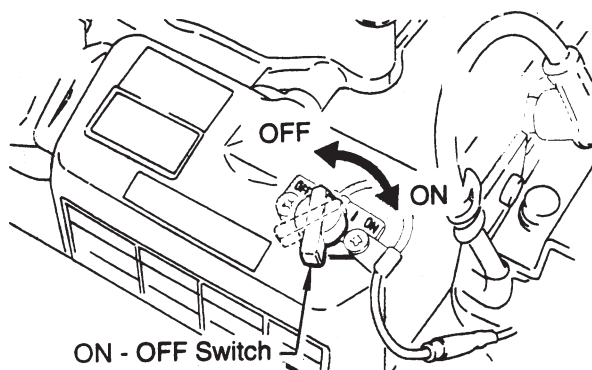

**Figure 8. On Off Switch**

3. Close the choke lever (Figure 9) and move the throttle lever to the **"Full Open"** position. Turning the choke lever 90 degrees clockwise closes the choke. In cold weather, start the unit with choke fully closed. In warm weather or when the engine is warm, the unit can be started with choke halfway or completely open.

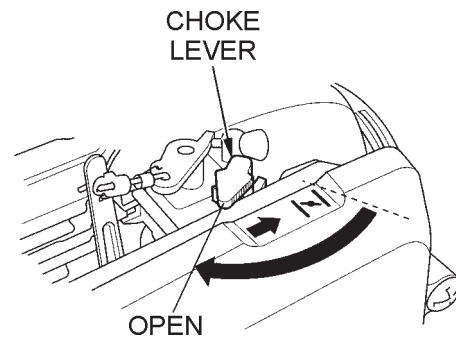

**Figure 9. Choke Lever**

4. Grip the recoil starter (Figure 10) handle and pull it until you feel a slight resistance. Then pull sharply and quickly. Return the recoil starter handle to the starter case before releasing.

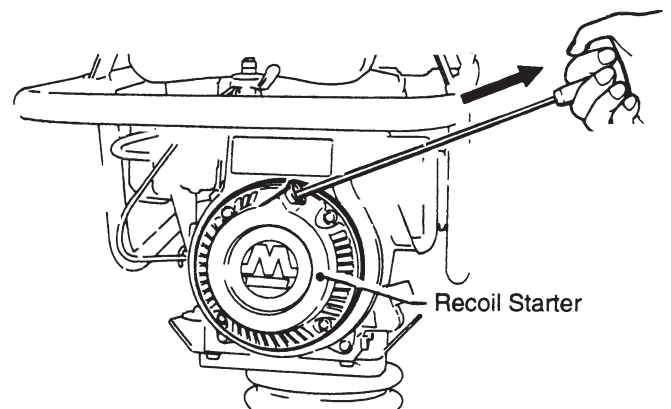

**Figure 10. Recoil Starter**

5. If engine fails to start, move the choke lever (Figure 9) to the half open position to avoid flooding.
6. Repeat steps 1 thru 4.
7. If the engine does not start after repeated attempts, check the spark plug for excess fuel. Clean and replace the spark plug as needed.

## Operation

1. To start the rammer tamping action, move the throttle lever (Figure 11) quickly from **IDLE** (close) to the **FULL OPEN** position. **DO NOT** move the throttle lever slowly as this may cause damage to the clutch or spring.

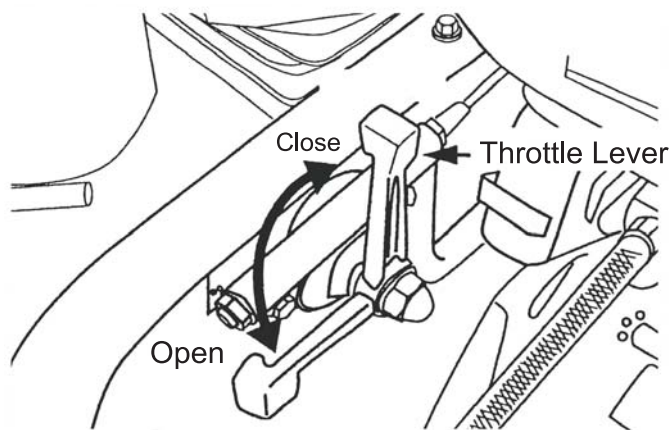

Figure 11. Throttle Lever (Full Open)

## CAUTION:



Make sure that the throttle lever is moved to the **FULL OPEN** position. Operating the rammer at less than full speeds can result in damage to the clutch springs or foot

2. The MT-74FA tamping rammer is designed to run at 4,000 rpm. At optimum rpm the foot hits at the rate of 680 impacts per minute. Increasing throttle speed past factory set rpm does not increase impacts and may damage unit. The MT-74FA is designed to advance while tamping. For faster advance, pull back slightly on the handle so that rear of foot contacts soil first.
3. To stop the tamping action, move throttle lever quickly from the **FULL OPEN** to **IDLE** position.

## Stopping The Engine

### Normal Shutdown

1. Move throttle lever quickly from the **FULL OPEN** to **IDLE** position (Figure 12) and run the engine for three minutes at low speed. After the engine **cools**, turn the engine start/stop switch to the "**STOP**" position (Figure 8) until engine comes to a complete stop.

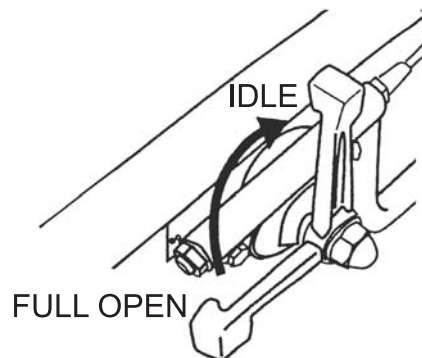

Figure 12. Throttle Lever (Idle)

2. Close the fuel shut-off valve by moving the fuel cock lever to the **CLOSED** position. See Figure 5.

### Emergency Showdown

1. Move the throttle lever quickly to the **IDLE** position, and turn the engine start/stop switch to the **STOP** position.

## Maintenance

Perform the scheduled maintenance procedures as indicated:

### DAILY

- Thoroughly remove dirt and oil from the engine and control area. Clean or replace the air cleaner elements as necessary. Check and retighten all fasteners as necessary. Check the spring box and bellows for oil leaks. Repair or replace as needed.

### WEEKLY

- Remove the fuel filter cap and clean the inside of the fuel tank.
- Remove or clean the filter at the bottom of the tank.
- Remove and clean the spark plug, then adjust the spark gap to 0.02~0.03 inch (0.6~0.7 mm). This unit has electronic ignition, which requires no adjustments.
- Clean air cleaner cover.

### 200 - 300 HOURS (Pre-Cleaner)

- Remove the element from the pre-cleaner (Figure 11) at the top of the crankcase (body side) and clean it with cleaning oil (kerosene).

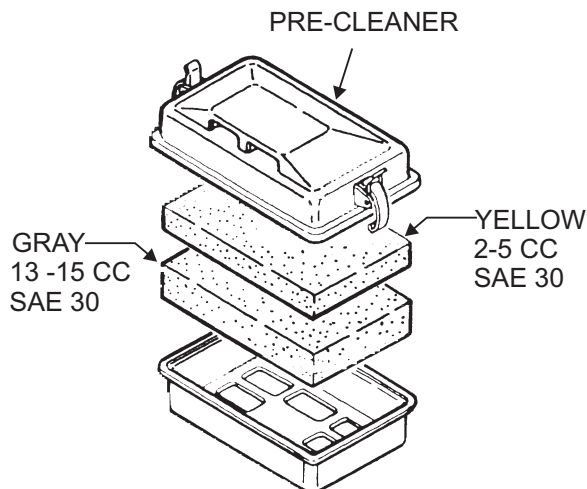

**Figure 11. Pre-Cleaner**

- Lubricate the top element (yellow) with 2~5 cc of engine oil SAE-30.
- Lubricate bottom element (gray) with 13 ~15 cc of engine oil SAE-30 and completely squeeze out the excess oil from the element before installing.

- The air cleaner (Figure 12 ) on the engine side will hardly be contaminated, if it is, however after cleaning the element with kerosene, dip it in mixed oil consisting of 3 parts of gasoline and 1 part of engine oil. Then tightly squeeze outer primary element (sponge) and shake off well the inner secondary element before installing them.

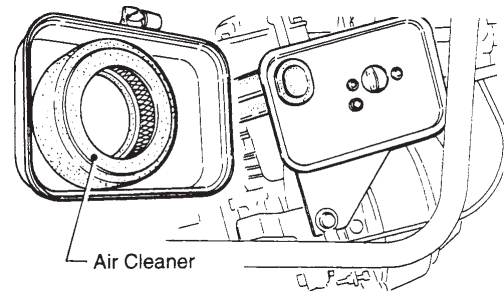

**Figure 12. Engine Air Cleaner**

### 200 - 300 HOURS (Oil Bath)

- Drain oil reservoir on foot housing (Figure 13). Refill with approximately 1.7 pt. (800cc) of 10W-30 motor oil. Oil should be midway in sight glass. Break in oil should be changed after first 50 hours.

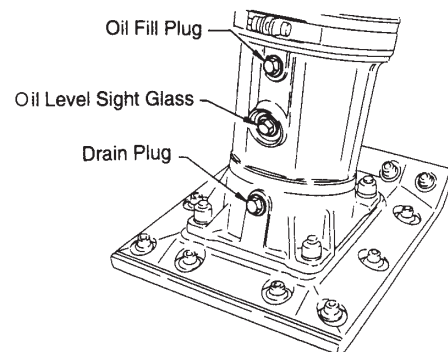

**Figure 13. Foot Housing Drain Plug**

### Yearly

- Check the fuel line and the oil line regularly for damage and to ensure that there are no leaks.
- Replace the oil and fuel lines every two years to maintain the performance and flexibility lines.

### Long Term Storage

- Drain fuel from fuel tank, fuel line and carburetor.
- Remove spark plug and pour a few drops of motor oil into cylinder. Crank engine 3 to 4 times so that oil reaches all internal parts.
- Clean exterior with a cloth soaked in clean oil.
- Store unit covered with plastic sheet in moisture free and dust free location out of direct sunlight

# MT-74FA — TROUBLESHOOTING GUIDE

**TABLE 4. ENGINE TROUBLESHOOTING**

SYMPTOM	POSSIBLE PROBLEM	SOLUTION
<b>Difficult to start</b>		
Fuel is available but spark plug will not ignite. (Power available at high tension cable).	Ignition plug being bridge?	Check ignition system.
	Carbon deposit at ignition?	Clean or replace ignition.
	Short circuit due to defective insulators?	Replace insulators.
	Improper spark gap?	Set spark plug gap to the correct gap.
Fuel is available but spark plug will not ignite. (Power <b>NOT</b> available at high tension cable).	Short circuit at stop switch?	Check stop switch circuit. Replace stop switch if defective.
	Ignition coil defective?	Replace ignition coil.
Fuel is available and spark plug ignites (compression <b>normal</b> ).	Muffler clogged with carbon deposits?	Clean or replace muffler.
	Fuel in use inadequate (water, dust)?	Flush fuel sytem and replace with fresh fuel.
	Air Cleaner clogged?	Clean or replace air cleaner.
Fuel is available and spark plug ignites (compression <b>low</b> ).	Defective cylinder head gasket?	Tighten cylinder head bolts or replace head gasket.
	Cylinder worn?	Replace cylinder.
	Spark plug loose?	Tighen spark plug.
<b>Operation not satisfactory</b>		
Not enough power available (compression normal, no misfiring).	Air cleaner clogged?	Clean or replace air cleaner.
	Air in fuel line?	Bleed (remove air) from fuel line.
	Carbon deposits in cylinder?	Clean or replace cylinder.
Not enough power available (compression normal, misfiring).	Ignition coil defective?	Flush fuel sytem and replace with fresh fuel.
	Ignition plug often shorts?	Replace ignition wires, clean ignition.
	Fuel in use inadequate (water, dust)?	Flush fuel sytem and replace with fresh fuel.
Engine overheats.	Mined fuel quality is inadequate?	Check fuel to oil mixture.
	Excessive carbon deposits in combustion chamber?	Clean or replace crankcase.
	Exhaust or muffler clogged with carbon?	Clean or replace muffler.
	Spark plug heat value incorrect?	Replace spark plug with correct type spark plug.

# MT-74FA — TROUBLESHOOTING GUIDE

**TABLE 4. ENGINE TROUBLESHOOTING (continued)**

SYMPTOM	POSSIBLE PROBLEM	SOLUTION
<b>Operation not satisfactory</b>		
Rotational speed fluctuates.	Governor adjustment improper?	Adjust governor to correct level.
	Governor spring defective?	Clean or replace ignition.
	Fuel flow erratic?	Check fuel line.
	Air taken in through suction line?	Check suction line.
Recoil starter not working properly.	Dust in rotating part?	Clean recoil starter assembly.
	Spiral spring failure?	Replace spiral spring.

**TABLE 5. RAMMER TROUBLESHOOTING**

SYMPTOM	POSSIBLE PROBLEM	SOLUTION
Engine runs but rammer jumps erratically or not at all.	Operating speed of throttle lever is incorrectly set?	Set throttle lever to correct position.
	Oil in excess?	Drain excess oil. Bring to correct level.
	Clutch slips?	Replace or adjust clutch.
	Spring Failure?	Replace spiral spring.
	Speed of engine improper?	Adjust engine speed to correct operating RPM setting.
	Soil over-compacted?	Shut down machine and test soil.

# EXPLANATION OF CODE IN REMARKS COLUMN

The following section explains the different symbols and remarks used in the Parts section of this manual. Use the help numbers found on the back page of the manual if there are any questions.

The contents and part numbers listed in the parts section are subject to change **without notice**. Multiquip does not guarantee the availability of the parts listed.

Sample Parts List:

NO.	PART NO.	PART NAME	QTY.	REMARKS
1	12345	BOLT .....	1	INCLUDES ITEMS W/*
2*		WASHER, 1/4 IN. ....		NOT SOLD SEPARATELY
2*	12347	WASHER, 3/8 IN. ... 1		MQ-45T ONLY
3	12348	HOSE .....	A/R	MAKE LOCALLY
4	12349	BEARING .....	1	S/N 2345B AND ABOVE

## NO. Column

**Unique Symbols** - All items with same unique symbol (\*, #, +, %, or >) in the number column belong to the same assembly or kit, which is indicated by a note in the "Remarks" column.

**Duplicate Item Numbers** - Duplicate numbers indicate multiple part numbers are in effect for the same general item, such as different size saw blade guards in use or a part that has been updated on newer versions of the same machine.



When ordering a part that has more than one item number listed, check the remarks column for help in determining the proper part to order.

## PART NO. Column

**Numbers Used** - Part numbers can be indicated by a number, a blank entry, or TBD.

TBD (To Be Determined) is generally used to show a part that has not been assigned a formal part number at time of publication.

A blank entry generally indicates that the item is not sold separately or is not sold by Multiquip. Other entries will be clarified in the "Remarks" Column.

## QTY. Column

**Numbers Used** - Item quantity can be indicated by a number, a blank entry, or A/R.

A/R (As Required) is generally used for hoses or other parts that are sold in bulk and cut to length.

A blank entry generally indicates that the item is not sold separately. Other entries will be clarified in the "Remarks" Column.

## REMARKS Column

Some of the most common notes found in the "Remarks" Column are listed below. Other additional notes needed to describe the item can also be shown.

**Assembly/Kit** - All items on the parts list with the same unique symbol will be included when this item is purchased.

Indicated by:

"INCLUDES ITEMS W/(unique symbol)"

**Serial Number Break** - Used to list an effective serial number range where a particular part is used.

Indicated by:

"S/N XXXXX AND BELOW"

"S/N XXXX AND ABOVE"

"S/N XXXX TO S/N XXX"

**Specific Model Number Use** - Indicates that the part is used only with the specific model number or model number variant listed. It can also be used to show a part is NOT used on a specific model or model number variant.

Indicated by:

"XXXXX ONLY"

"NOT USED ON XXXX"

**"Make/Obtain Locally"** - Indicates that the part can be purchased at any hardware shop or made out of available items. Examples include battery cables, shims, and certain washers and nuts.

**"Not Sold Separately"** - Indicates that an item cannot be purchased as a separate item and is either part of an assembly/kit that can be purchased, or is not available for sale through Multiquip.

# MT-74FA — SUGGESTED SPARE PARTS

## MT-74FA RAMMER 1 TO 3 UNITS

QTY	PART NO	DESCRIPTION	REMARKS
1	.. 362910060	..... THROTTLE LEVER ASSY	
1	.. 956100045	..... THROTTLE WIRE	
3	.. 354030030	..... ELEMENT, YELLOW	
3	.. 354030040	..... ELEMENT, GRAY	
1	.. 361910070	..... CAP, FUEL TANK	
1	.. 954300720	..... COCK, FUEL ASSY.	
1	.. 26365012A3	... FILTER, FUEL	
3	.. 2523260207	... ELEMENT, SET, ENGINE	
1	.. 0660000371	... STOP SWITCH ASSY	
3	.. 0650140580	... SPARK PLUG	
1	.. 954406010	..... STRAINER, FUEL TANK	
1	.. 2695011008	... STARTER ROPE	

## MT-74FA RAMMER 3 TO 5 UNITS

QTY	PART NO	DESCRIPTION	REMARKS
1	.. 362910060	..... THROTTLE LEVER ASSY	.. S/N L1292 AND ABOVE
1	.. 956100045	..... THROTTLE WIRE	
5	.. 354030030	..... ELEMENT, YELLOW	
5	.. 354030040	..... ELEMENT, GRAY	
2	.. 354336352	..... CLAMP, BELLOWS	
1	.. 354010010	..... BELLOWS	
1	.. 361910070	..... CAP, FUEL TANK	
1	.. 954300720	..... COCK, FUEL ASSY.	
5	.. 2523260207	... ELEMENT, SET, ENGINE	
1	.. 0660000371	... STOP SWITCH ASSY	
5	.. 0650140580	... SPARK PLUG	
1	.. 954406010	..... STRAINER, FUEL TANK	
1	.. 2695011008	... STARTER ROPE	

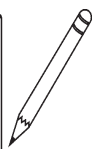
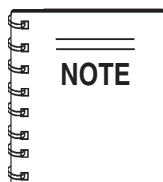

Part numbers on this Suggested Spare Parts List may supersede/replace the P/N shown in the text pages of this book.



# MT-74FA— NAMEPLATE AND DECAL

## NAME PLATE AND DECALS

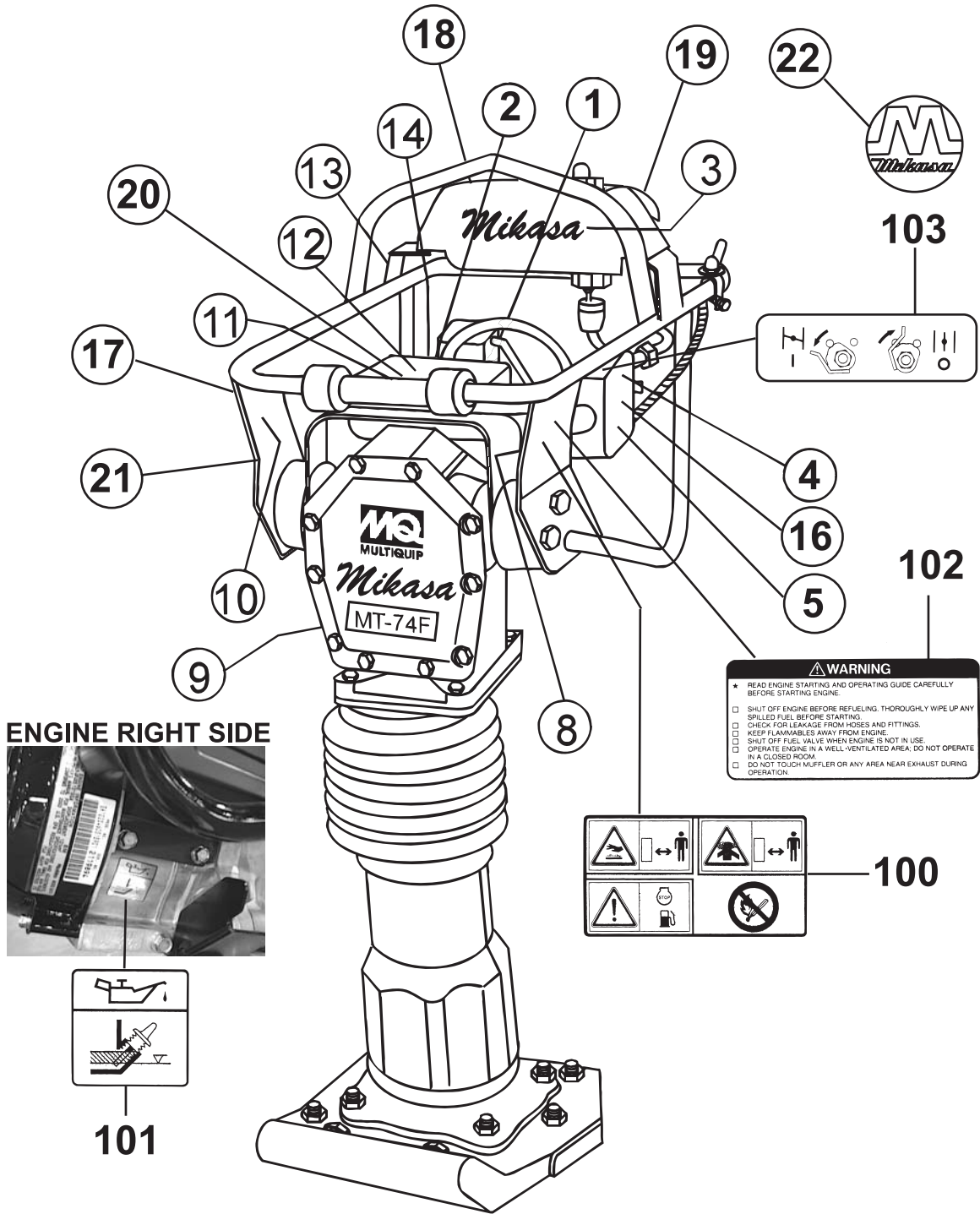



# MT-74FA— NAMEPLATE AND DECAL

## NAME PLATE AND DECALS

<u>NO</u>	<u>PART NO</u>	<u>PART NAME</u>	<u>QTY.</u>	<u>REMARKS</u>
1	920202930	DECAL: START SWITCH .....	1 .....	NPA293
2	920206020	DECAL: 3400 ~ 3600 RPM .....	1 .....	NPA602
3	920106460	DECAL: MIKASA .....	1	
4	920210160	DECAL: SERVICE MONTHLY .....	1 .....	NPA1016
5	920108310	DECAL: CLEANER ELEMENT .....	1 .....	NPA-831
8	920203290	DECAL: CAUTION .....	1 .....	NPA329
9		PLATE, SERIAL NO. ....	1 .....	CONTACT MQ SERVICE DEPT. W/ MODEL & S/N
10	920107000	DECAL: PRE-CLEANER .....	1 .....	NP700
11	920204370	DECAL: PRE-CLEANER .....	1 .....	NPA437
12	920209750	DECAL: CAUTION 4 CYCLE .....	1 .....	NPA975
13	920203330	DECAL: EAR PROTECTION .....	1 .....	NPA333
14	920203990	DECAL: CAUTION (FUEL COCK) ....	1 .....	NPA399
16	920203980	DECAL: ELEMENT SET .....	1 .....	NPA398
17	920207690	DECAL: CAUTION (MANUAL) .....	1 .....	NPA769
18	920210170	DECAL: GASOLINE ONLY .....	1 .....	NPA1017
19	920208960	TAG, GASOLINE .....	1 .....	NPA896
20	920210180	DECAL, CHECK DAILY (FILTER) .....	1 .....	NPA1018
21	920209100	DECAL, CAUTION (RAMMER) .....	1 .....	NPA910
22	920100240	DECAL (M-MARK) .....	1 .....	NP24
100	0732004450	LABEL, CAUTION .....	1	
101	0732004520	LABEL, OIL CAUTION .....	1	
102	0732003900	LABEL, WARNING .....	1	
103	0732005020	LABEL, CHOKE .....	1	

# MT-74FA — CRANKCASE AND ENGINE ASSY.

## CRANKCASE AND ENGINE ASSY.

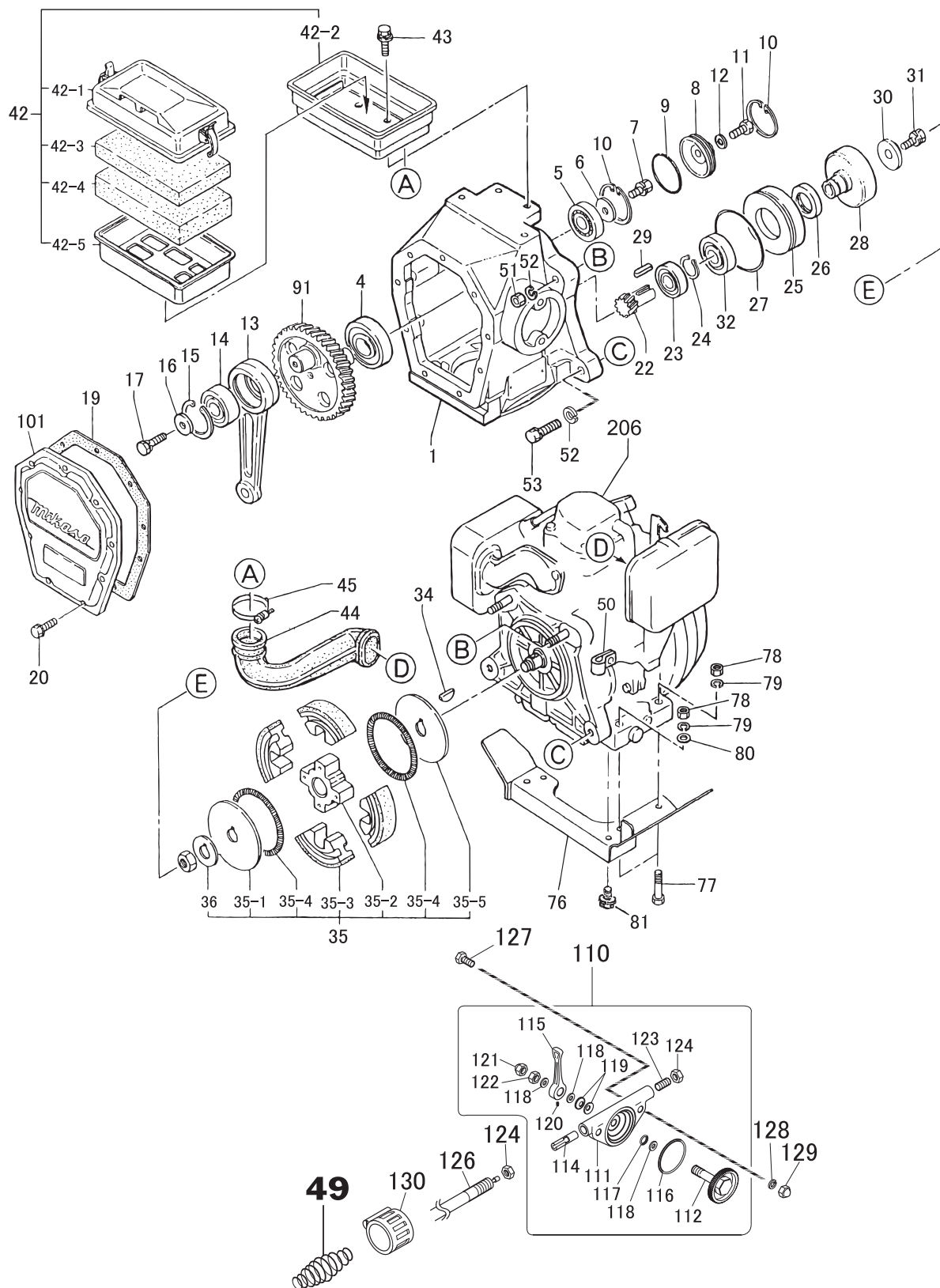

# MT-74FA — CRANKCASE AND ENGINE ASSY.

## CRANKCASE AND ENGINE ASSY.

NO.	PART NO.	PART NAME	QTY.	REMARKS
1	361118270	CRANK CASE	1	
4	040006207	BEARING 6207	1	
5	040006204	BEARING 6204	1	
6	952400130	WASHER 9304	1	
7	002210825	BOLT 8X25 H, SW	1	
8	371447650	BEARING COVER	1	
9	050300480	O-RING S-48	1	
10	080100480	STOP RING R-48	2	
11	001220610	BOLT 6X10 T	1	
12	031106100	WASHER M5	1	
13	371334730	CONNECTING ROD	1	
14	040006304	BEARING 6304	1	
15	080100520	STOP RING R-52	1	
16	952400130	WASHER 9304	1	
17	002210825	BOLT 8X25 H, SW	1	
19	352444450	PACKING, FRONT COVER	1	
20	002200620	BOLT 6X20 H, SW	9	
22	361449320	PINION	1	
23	040006204	BEARING 6204	1	
24	080200350	STOP RING S-35	1	
25	371449600	SPACER	1	
26	060404010	OIL SEAL TC-40528	1	
27	050101000	O-RING G-100	1	
28	361449330	CLUTCH DRUM	1	
29	951407340	KEY 5X5X20R	1	
30	952405490	LOCK WASHER	1	
31	002210820	BOLT 8X20 H, SW	1	
32	041006007	BEARING 6007Z	1	
34	0053204201	WOODRUFF KEY	1	
35	362454441	CLUTCH ASSY CE120P .....	1	INCLUDES ITEMS W/ *
35-1*	943060020	CLUTCH GUIDE/B	1	
35-2*	943050050	CLUTCH BOSS C812	1	
35-3*	943020020	CLUTCH SHOE C812	4	
35-4*	943030021	CLUTCH SPRING C812	2	
35-5*	943060100	CLUTCH GUIDE/A 1.6T	1	
36*	301010210	LOCK WASHER, CLUTCH	1	
42	361213800	AIR CLEANER ASSY .....	1	INCLUDES ITEMS W/ #
42-1#	354030011	BODY /W-CLEANER	1	
42-2#	361010020	BACK PLATE CP	1	
42-3#	354030030	ELEMENT, YELLOW	1	
42-4#	354030040	ELEMENT, GRAY	1	
42-5#	354030050	ELEMENT FRAME	1	



# MT-74FA — CRANKCASE AND ENGINE ASSY.

## CRANKCASE AND ENGINE ASSY. CONTINUED

<u>NO</u>	<u>PART NO</u>	<u>PART NAME</u>	<u>QTY.</u>	<u>REMARKS</u>
43	002200820	BOLT 8X20 H, SW	4	
44	361336010	INTAKE PIPE	1	
45	954010230	HOSE BAND (B)	1	
49	0830000010	COIL SPRING	1	
50	959006120	CLIP	1	
51	020310080	NUT M10	2	
52	030210250	SW M10	4	
53	001221050	BOLT 10X50 H, SW	2	
76	361214201	UNDER PROTECTOR	1	
77	001220840	BOLT 8X40 T	3	
78	020308060	NUT M8	3	
79	030208200	SW M8	3	
80	031108160	PW M8	3	
81	0011308180	BOLT AND WASHER ASSY	2	
91	361335870	CRANK GEAR	1	
101	361010030	FRONT COVER	1	
110	362910060	THROTTLE LEVER ASSY .....	1	INCLUDES ITEMS W/ %
111%	362341550	THROTTLE BODY	1	
112%	362910090	THROTTLE GEAR CP, W/ BOLT	1	
114%	362455620	SLIDER	1	
115%	362455630	THROTTLE LEVER	1	
116%	050100450	O-RING G-45	1	
117%	050200100	O-RING P-10	1	
118%	031110160	PW M10	3	
119%	033910070	CONICAL SPRING WASHER	2	
119	032110180	CONICAL SPRING WASHER M10	2	
120%	096206006	SOCKET HEAD SCREW 6 X 6	1	
121%	022131008	CAP NUT M10	1	
122%	020410060	NUT M10	1	
123%	096208020	SOCKET HEAD SCREW 8X20	1	
124	020408050	NUT M8	2	
126	956100045	THROTTLE WIRE	1	
127	001220620	BOLT 6X20 T	2	
128	030206150	SW M6	2	
129	022130605	CAP NUT M6	2	
130	303010450	BAND	1	
206	911211214	ENGINE, EH-12-2D	1	

# MT-74FA — GUIDE CYLINDER AND FOOT ASSY.

GUIDE CYLINDER AND FOOT ASSY.

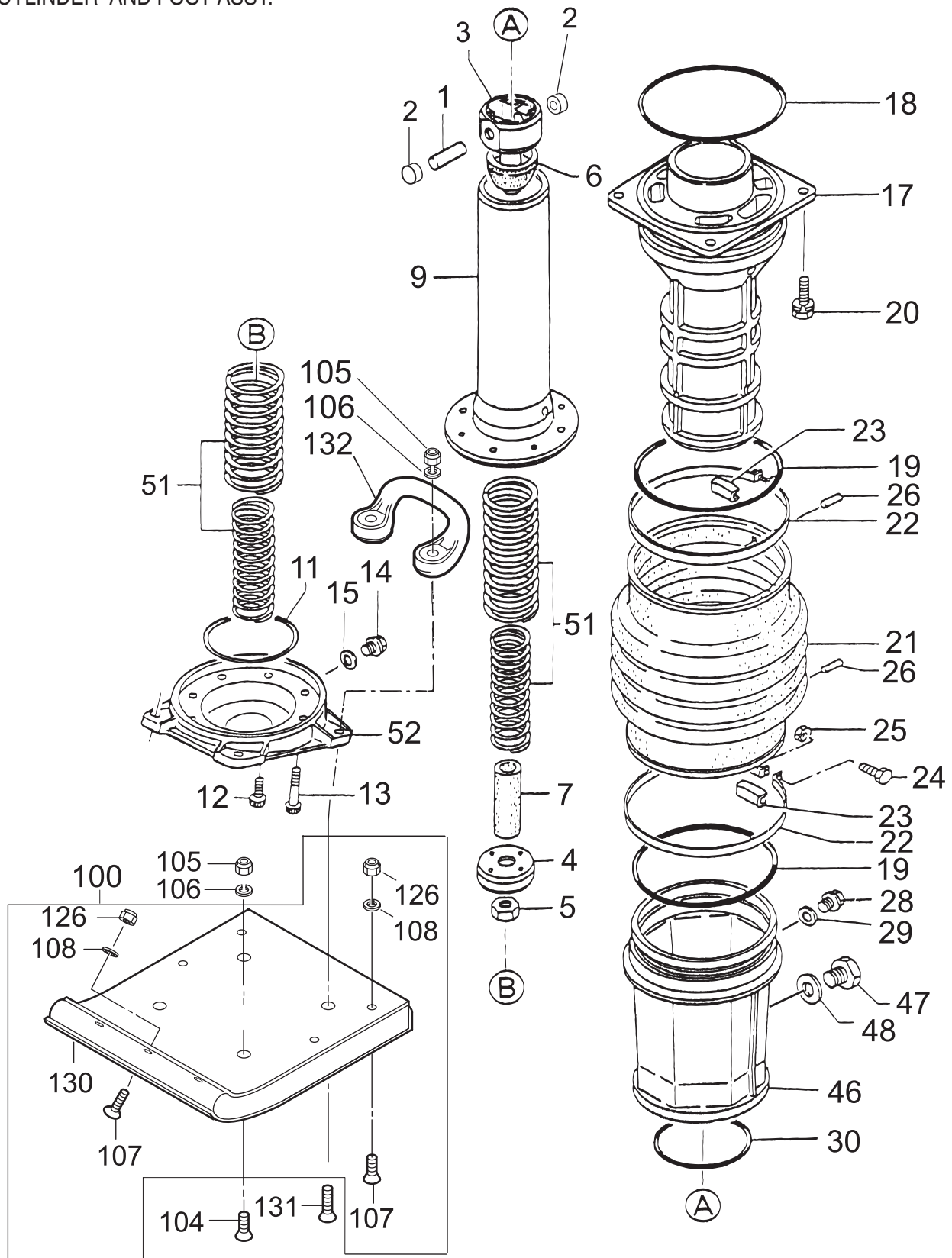

# MT-74FA — GUIDE CYLINDER AND FOOT ASSY.

## GUIDE CYLINDER AND FOOT ASSY.

NO.	PART NO.	PART NAME	QTY.	REMARKS
1	352423290	PISTON PIN	1	
2	363457870	PISTON PIN PLUG	2	
3	361344360	PISTON ROD	1	
4	355452340	PISTON END	1	
5	020118150	NUT M18, P1.5	1	
6	355447250	STOPPER UPPER	1	
7	355447260	STOPPER, LOWER	1	
8	355447270	MAIN SPRING	2	
9	355334310	SPRING CYLINDER	1	
11	050100900	O-RING G-90	1	
12	014210020	SOCKET HEAD BOLT 10X20 T .....	4	REPLACES 001521020
13	014210040	SOCKET HEAD BOLT 10X40 T .....	4	REPLACES 001521040
14	953405270	PLUG 1/4X14 13L	1	
15	953405260	PACKING 1/4 (CU)	1	
17	355213010	GUIDE CYLINDER	1	
18	050201500	O-RING P-150	1	
19	050931500	O-RING JASO3150	2	
20	012710035	BOLT 10X35 H, SW .....	4	REPLACES 002211035
21	354010010	BELLOWS(L) ORANGE	1	
22	354336352	BELLOWS CLAMP .....	2	REPLACES 354329380
23	354442340	BAND GUIDE, BELLOWS	2	
24	011008040	BOLT 8X40 H .....	2	REPLACES 001220840
25	020108060	NUT M8 .....	2	REPLACES 020308060
26	354446170	PIN 6D-8.5L	2	
28	953405270	PLUG 1/4X14 13L	2	
29	953405260	PACKING 1/4 (CU)	2	
30	050100950	O-RING G-95 .....	1	S/N R5624 AND BELOW
30	050200950	O-RING P-95 .....	1	S/N R5625 AND ABOVE
46	355113960	PROTECTION SLEEVE .....	1	S/N R5624 AND BELOW
46	355119030	PROTECTION SLEEVE .....	1	S/N R5625 AND ABOVE
47	959010150	LEVEL GAUGE, PLUG TYPE	1	
48	953404670	COPPER PACKING 17X25.5X1	1	
51	355447270	MAIN SPRING	2	
52	355213000	FOOT PLATE 16	1	
100	362910130	FOOT ASSY .....	1	INCLUDES ITEMS W/ *
104	001611253	SUNK HEAD BOLT 12 X65 H	2	
105	021112140	NYLON NUT M12 .....	4	REPLACES 022711214
106	030212300	WASHER SW M12	4	
107*	015110055	SUNK HEAD BOLT 10X55 H .....	7	REPLACES 001611051
108*	030210250	WASHER SW M10	7	
126*	021110120	NYLON NUT M10 .....	7	REPLACES 022711012
130*	362910130	FOOT ASSY 285W-SF-EXP	1	
131	001611259	SUNK HEAD BOLT 12X95 H	2	
132	363343390	HANDLE	1	



# MT-74FA — TANK AND HANDLE ASSY.

## TANK AND HANDLE ASSY.

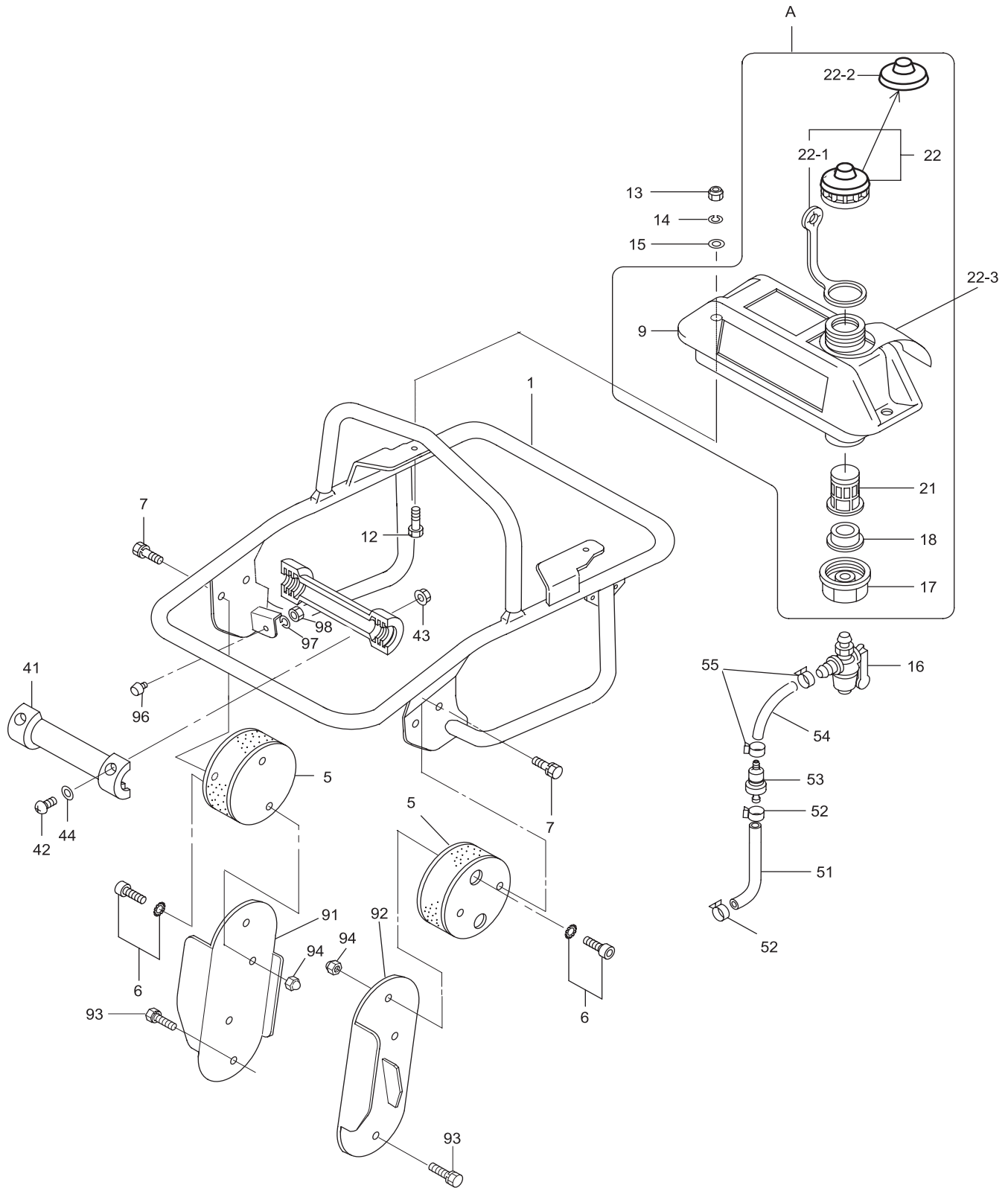



# MT-74FA — TANK AND HANDLE ASSY.

## TANK AND HANDLE ASSY.

<u>NO</u>	<u>PART NO</u>	<u>PART NAME</u>	<u>QTY.</u>	<u>REMARKS</u>
A	305910032	FUEL TANK ASSY .....	1	INCLUDES ITEMS W/ #
1	361118300	HANDLE	1	
5	351337070	SHOCK ABSORBER	2	
6	009110007	GT CAP SA, 10X20	4	
7	012210020	BOLT 10X20 H, SW .....	4	REPLACES 002211020
9#	362116890	FUEL TANK, GRAY	1	
12	011208030	BOLT 8X30 T .....	2	REPLACES 001220830
13	022710809	NYLON NUT M8	2	
14	030208200	WASHER, SW M8	2	
15	952401450	WASHER 8.5X22X3	2	
16	954300720	FUEL COCK ASSY	1	
17#	351437785	HOLDER, FUEL COCK	1	
18#	954406020	PACKING, COCK FUEL	1	
21#	954406010	STRAINER	1	
22#	361910070	CAP ASSY, TANK .....	1	INCLUDES ITEM W/ %
22-1#%	353449010	STRAP, FUEL TANK CAP	1	
22-2#%	361455740	SUB CAP (B)	1	
22-3#	920208960	TAG, GASOLINE	1	
41	955200053	ROLLER, W/ PIN	2	
42	091005025	SCREW 5 X 25	4	
43	022610505	FLANGE NUT M5 H	4	
44	031105080	PW M5	4	
51	959021721	FUEL HOSE/D4.5 X D9 X150L	1	
51	950014500150M	FUEL HOSE (1M)	1	
52	950024085008	CLAMP, TUBE	2	
53	26365012A3	FILTER, FUEL	1	
54	959026121	FUEL HOSE/D5.5 X D11.5 X 170L	1	
54	959026199	FUEL HOSE/1M	1	
55	954406420	HOSE BAND 10.5	2	
91	361458840	STAY, SHOCK ABSORBER/R	1	
92	361458850	STAY, SHOCK ABSORBER/L	1	
93	002211025	BOLT 10 X 25 H, SW	4	
94	022131008	CAP NUT M10	4	
96	939010270	STOPPER RUBBER (70)	1	
97	030208200	SW M8	1	
98	020308060	NUT M8	1	

# ROBIN EH-12-2D46420 ENGINE — CRANKCASE AND CYLINDER ASSY.

CRANKCASE AND CYLINDER ASSY.

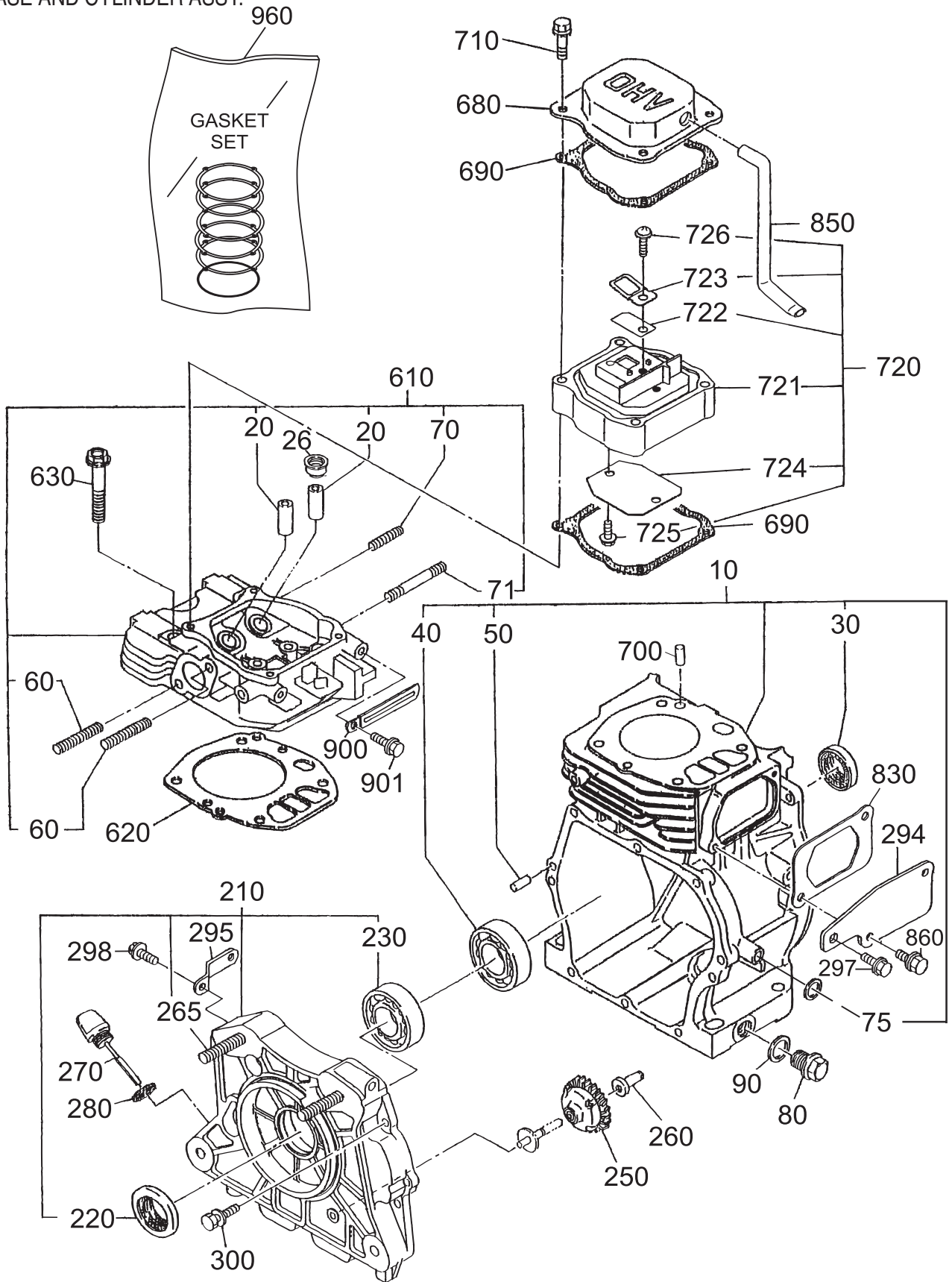

# ROBIN EH-12-2D46420 ENGINE — CRANKCASE AND CYLINDER ASSY.

## CRANKCASE AND CYLINDER ASSY.

<u>NO.</u>	<u>PART NO.</u>	<u>PART NAME</u>	<u>QTY.</u>	<u>REMARKS</u>
10	2521030131	CRANK CASE .....	1	INCLUDES ITEMS W/ %
20#	2371420203	VALVE GUIDE, OVERSIZE	2	
26#	2771601001	STEM SEAL	1	
30%	0440250150	OIL SEAL	1	
40%	0600250100	BALL BEARING	1	
50%	0310060020	DOWEL PIN	2	
60#	0105080480	STUD	2	
70#	0105060131	STUD	1	
71#	0013906600	STUD	1	
75%	0440080010	OIL SEAL VC 8X14X4	1	
80	0401140030	PLUG	2	
90	0211140020	GASKET	2	
210	2521110121	MAIN BEARING COVER CP .....	1	INCLUDES ITEMS W/ \$
220\$	0440250160	OIL SEAL	1	
230\$	0600250010	BALL BEARINGS 6205C3	1	
250	2274500301	GOVERNOR GEAR COMPL	1	
260	2054190103	GOVERNOR SLEEVE	1	
265\$	0108100020	STUD	2	
270	2686360301	OIL GAUGE CP	1	
280	0213160020	GASKET	1	
294	2521700201	BRACKET CP (M.B.C.)	1	
295	2521700101	SUPPORT (M.B.C)	1	
297	0011308160	BOLT & WASHER ASSY	1	
298	0011308160	BOLT & WASHER ASSY	2	
300	0130060200	BOLT & WASHER ASSY	8	
610	2681310121	CYLINDER HEAD CP .....	1	INCLUDES ITEMS W/ #
620	2531500123	GASKET, HEAD	1	
630	0110080100	FLANGE BOLT	4	
680	2521550203	ROCKER COVER	1	
690	2691600403	GASKET, ROCKER COVER	2	
700	0310060020	DOWEL PIN	2	
710	0110060170	FLANGE BOLT EY45V	4	
720	2521560120	SPACER ASSY, BREATHER .....	1	INCLUDES ITEMS W/ *
721*	2521560113	SPACER, BREATHER	1	
722*	2521600103	LEAF VALVE	1	
723*	2521610103	RETAINER PLATE	1	
724*	2521440123	PLATE	1	
725*	0110060150	FLANGE BOLT EH11	2	
726*	0043506120	SCREW & WASHER	1	
830	2681620103	GASKET, BREATHER COVER	1	
850	2521800203	RUBBER PIPE	1	
860	0011306160	BOLT AND WASHER ASSY	2	
900	0566000250	CLAMP	1	
901	0110060020	FLANGE BOLT	1	
960	2539900117	GASKET SET	1	

# ROBIN EH-12-2D46420 ENGINE — CRANKSHAFT AND PISTON ASSY.

CRANKSHAFT AND PISTON ASSY.

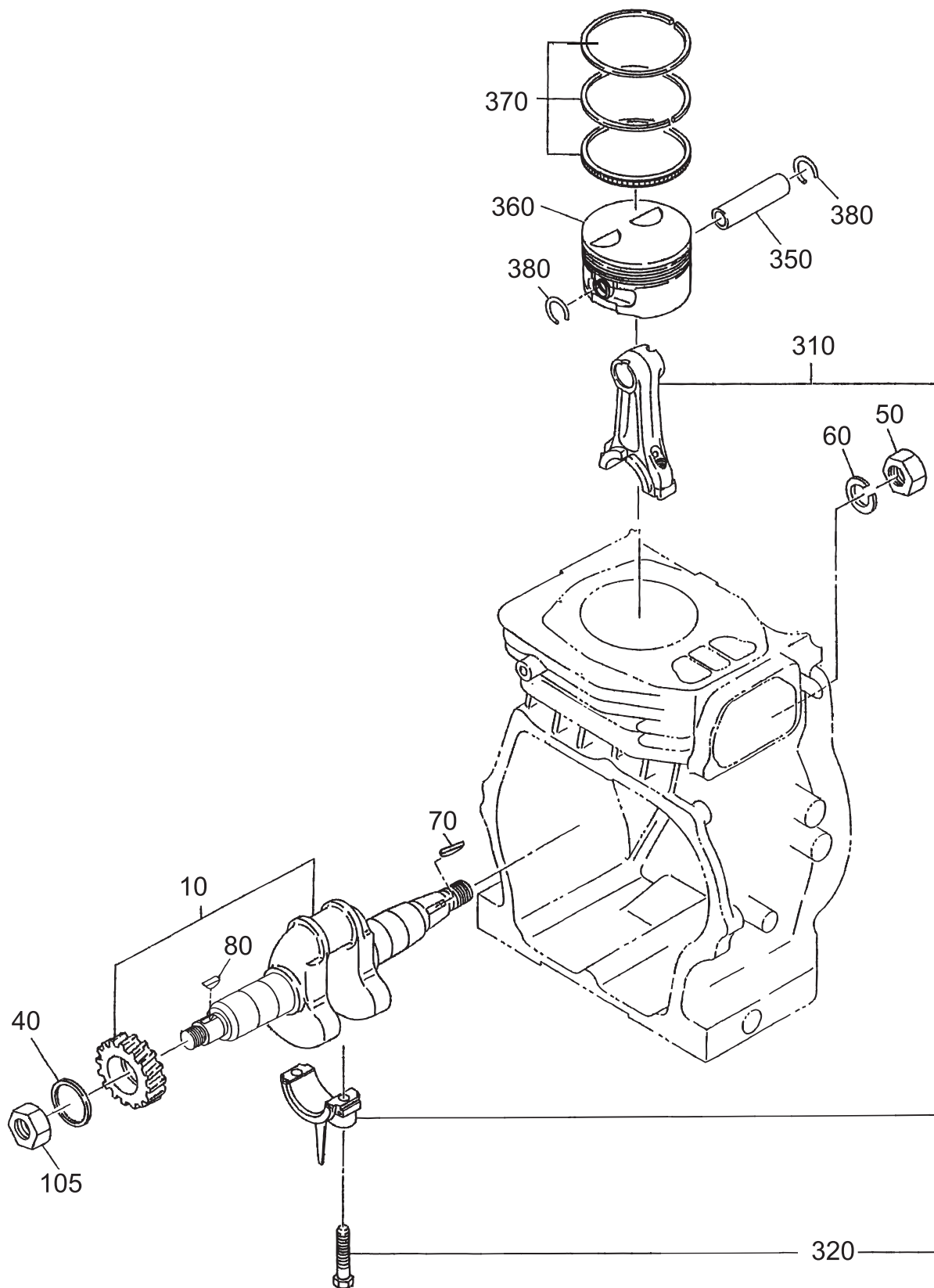

# ROBIN EH-12-2D46420 ENGINE — CRANKSHAFT AND PISTON ASSY.

## CRANKSHAFT AND PISTON ASSY.

<u>NO.</u>	<u>PART NO.</u>	<u>PART NAME</u>	<u>QTY.</u>	<u>REMARKS</u>
10	6821901111	CRANKSHAFT CP	1	
40	0230250110	SPACER T=0.6 .....	1	SELECT
40	0230250120	SPACER T=0.8 .....	1	SELECT
40	0230250130	SPACER T=1.0 .....	1	SELECT
50	0021814000	NUT	1	
60	0032014000	SPRING WASHER	1	
70	0323030010	WOODRUFF KEY	1	
80	0053204201	WOODRUFF KEY	1	
105	0173120010	LOCK NUT	1	
310	2522250110	CONNECTING ROD ASSY .....	1	INCLUDES ITEM W/ *
320*	2362300103	CONNECTING ROD BOLT	2	
350	2682330103	PISTON PIN	1	
360	2682340103	PISTON STD.	1	
360	2682340203	PISTON O.S. 0.25MM	1	
360	2682340303	PISTON O.S. 0.50MM	1	
370	2522350117	PISTON RING SET STD	1	
370	2522350217	PISTON RING SET 0.25 O.S.	1	
370	2522350307	PISTON RING SET 0.50 O.S.	1	
380	2152500403	CLIP	2	

# ROBIN EH-12-2D46420 ENGINE—MUFFLER, AIR CLEANER, CAM& CARB. ASSY.

MUFFLER, AIR CLEANER, CAMSHAFT & CARBURETOR ASSY.

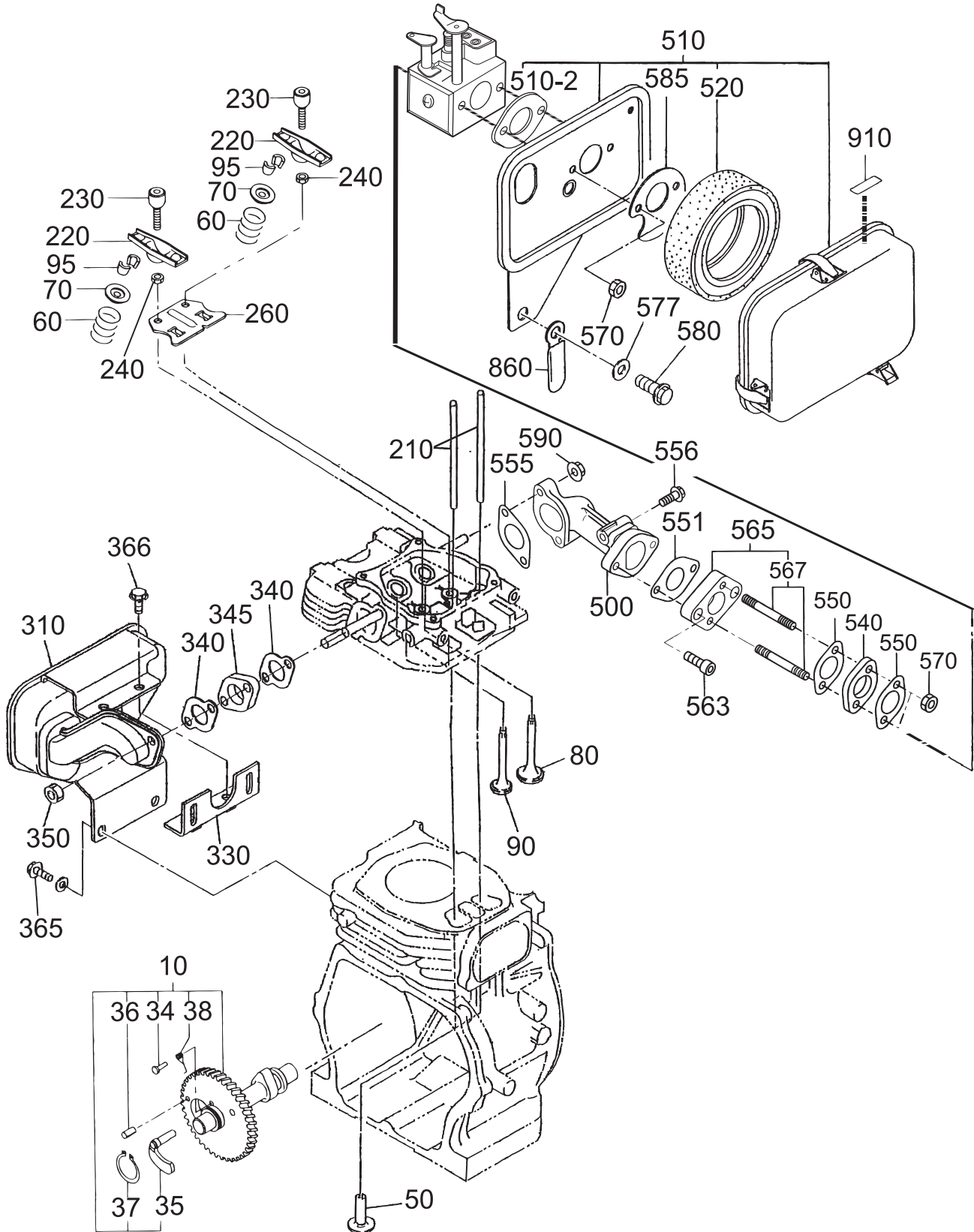

# ROBIN EH-12-2D46420 ENGINE—MUFFLER, AIR CLEANER, CAM& CARB. ASSY.

MUFFLER, AIR CLEANER, CAMSHAFT & CARBURETOR ASSY.

<u>NO.</u>	<u>PART NO.</u>	<u>PART NAME</u>	<u>QTY.</u>	<u>REMARKS</u>
10	2533170111	CAMSHAFT CP .....	1 .....	INCLUDES ITEMS W/ *
34*	2273860123	PIN (SPRING)	1	
35*	2273640113	RELEASE LEVER	1	
36*	0051904100	SPRING PIN	1	
37*	0031522000	SNAP RING	1	
38*	2273870103	RETURN SPRING	1	
50	2393330113	TAPPET	2	
60	2533360103	VALVE SPRING	2	
70	2693370103	SPRING RETAINER	2	
80	2683340103	INTAKE VALVE	1	
90	2683350103	EXHAUST VALVE	1	
95	13210KA031	COLLECT VALVE	4	
210	2683530103	PUSH ROD	2	
220	2693600103	ROCKER ARM	2	
230	2693580103	BOLT, PIVOT	2	
240	0170060090	NUT	2	
260	2693650103	GUIDE PLATE	1	
310	2523040111	MUFFLER CP	1	
330	2523700111	BRACKET CP	1	
340	2533520103	GASKET, MUFFLER	2	
345	2523650103	SPACER, EXHAUST	1	
350	0176080020	SELF-LOCK NUT	2	
365	0011308160	BOLT & WASHER ASSY	2	
366	0011408160	BOLT & WASHER 8 X 16	2	
500	2683300413	INTAKE PIPE CP	1	
505	0105060230	STUD	2	
510	2683271500	AIR CLEANER ASSY .....	1 .....	INCLUDES ITEMS W/ \$
510-2\$	1063272308	PACKING	1	
520\$	2523260207	ELEMENT, SET	1	
540	2523290103	INSULATOR	1	
550	2373590303	GASKET (CARBURETOR)	2	
551	1066500203	GASKET 2 (INSULATOR)	1	
555	2823590103	GASKET (INSULATOR)	1	
556	0011406400	BOLT AND WASHER ASSY	1	
563	0119060020	BOLT (SOCKET HEAD)	2	
565	2523310221	INTAKE FLANGE .....	1 .....	INCLUDES ITEM W/ #
567#	0105050060	STUD	2	
570	0176050010	SELF LOCK NUT	2	
577	0200080080	WASHER	1	
580	0011308180	BOLT & WASHER ASSY	1	
585	2683650303	PLATE, AIR CLEANER	2	
590	0023806000	FLANGE NUT	2	
860	0566000250	CLAMP	1	
910	0732005020	LABEL CHOKE	1	



# ROBIN EH-12-2D46420 ENGINE — GOVERNOR ASSY.

GOVERNOR ASSY.

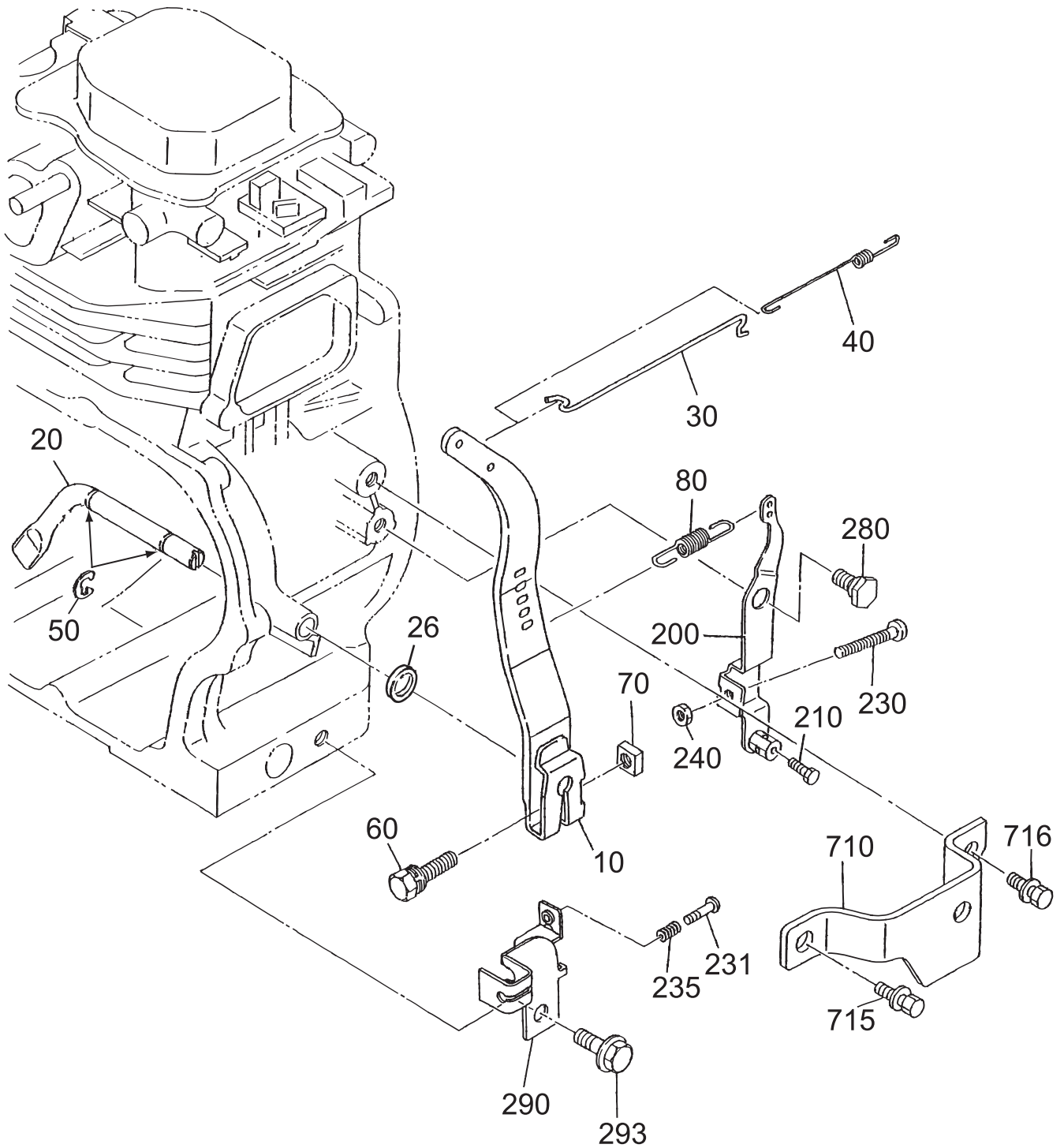

# ROBIN EH-12-2D46420 ENGINE — GOVERNOR ASSY.

GOVERNOR ASSY.

<u>NO.</u>	<u>PART NO.</u>	<u>PART NAME</u>	<u>QTY.</u>	<u>REMARKS</u>
10	2524230303	GOVERNOR LEVER CP	1	
20	2264230207	GOVERNOR SHAFT .....	1	REPLACES 2274220103
26	0031108000	WASHER	1	
30	2544270101	GOVERNOR ROD CP	1	
40	2544280103	ROD SPRING	1	
50	0031306000	CLIP	2	
60	0011406300	BOLT & WASHER ASSY	1	
70	0186060020	NUT	1	
80	2524250323	GOVERNOR SPRING	1	
200	2524340230	SPEED CONTROL ASSY	1	
210	0116040030	BOLT	1	
230	0043105250	SCREW, PANHEAD	1	
231	0043104250	SCREW	1	
235	2684500113	CONTROL SPRING	1	
240	0021705000	NUT	1	
280	2264310101	LINK PIVOT	1	
290	2524420213	WIRE BRACKET	1	
293	0110060030	FLANGE BOLT	1	
710	2524280111	PROTECTOR CP, GOVERNOR	1	
715	0011308160	BOLT & WASHER ASSY	1	
716	0110060030	FLANGE BOLT	1	

# ROBIN EH-12-2D46420 ENGINE —RECOIL STARTER AND BLOWER ASSY.

RECOIL STARTER AND BLOWER ASSY.

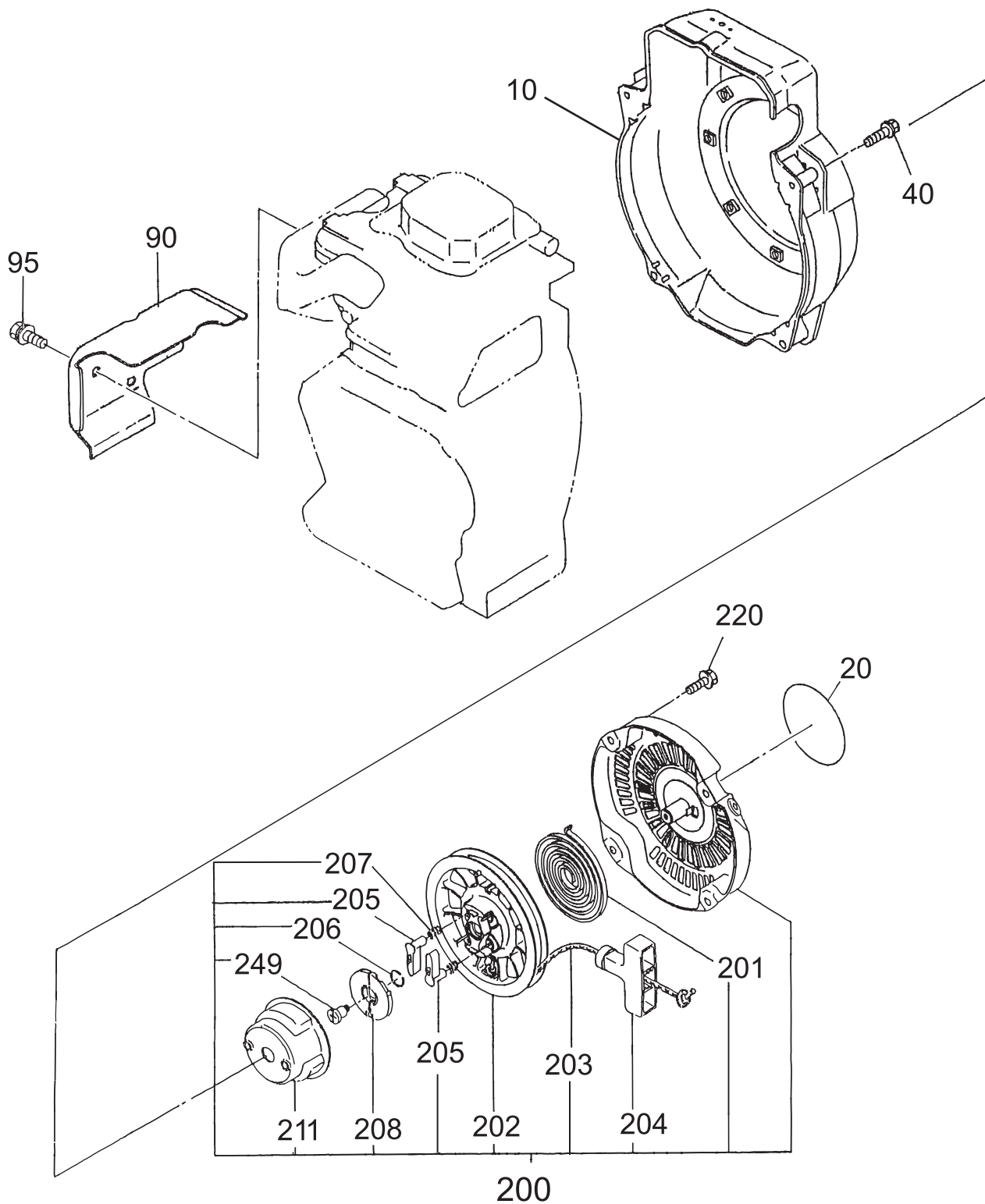

# ROBIN EH-12-2D46420 ENGINE —RECOIL STARTER AND BLOWER ASSY.

## RECOIL STARTER AND BLOWER ASSY.

<u>NO.</u>	<u>PART NO.</u>	<u>PART NAME</u>	<u>QTY.</u>	<u>REMARKS</u>
10	2525165221	BLOWER HOUSING CP 2	1	
20	920100240	DECAL, M-MARK	1	
40	0011406550	BOLT & WASHER ASSY	4	
90	2685270303	HEAD COVER	1	
95	0110060140	FLANGE BOLT	2	
200	2685020130	RECOIL STARTER ASSY .....	1	INCLUDES ITEMS W/*
201*	2705011508	SPIRAL SPRING	1	
202*	2695012008	REEL	1	
203*	2695011008	STARTER ROPE	1	
204*	2615010008	STARTER KNOB	1	
205*	2705012508	RATCHET	2	
206*	2275013108	FRICTION SPRING	1	
207*	2275013508	RETURN SPRING	2	
208*	2705026108	RATCHET GUIDE	1	
211*	2685014508	STARTER PULLEY	1	
220	0110060010	FLANGE BOLT	4	
249*	2275015208	SET SCREW	1	

# ROBIN EH-12-2D46420 ENGINE — MAGNETO ASSY.

MAGNETO ASSY.

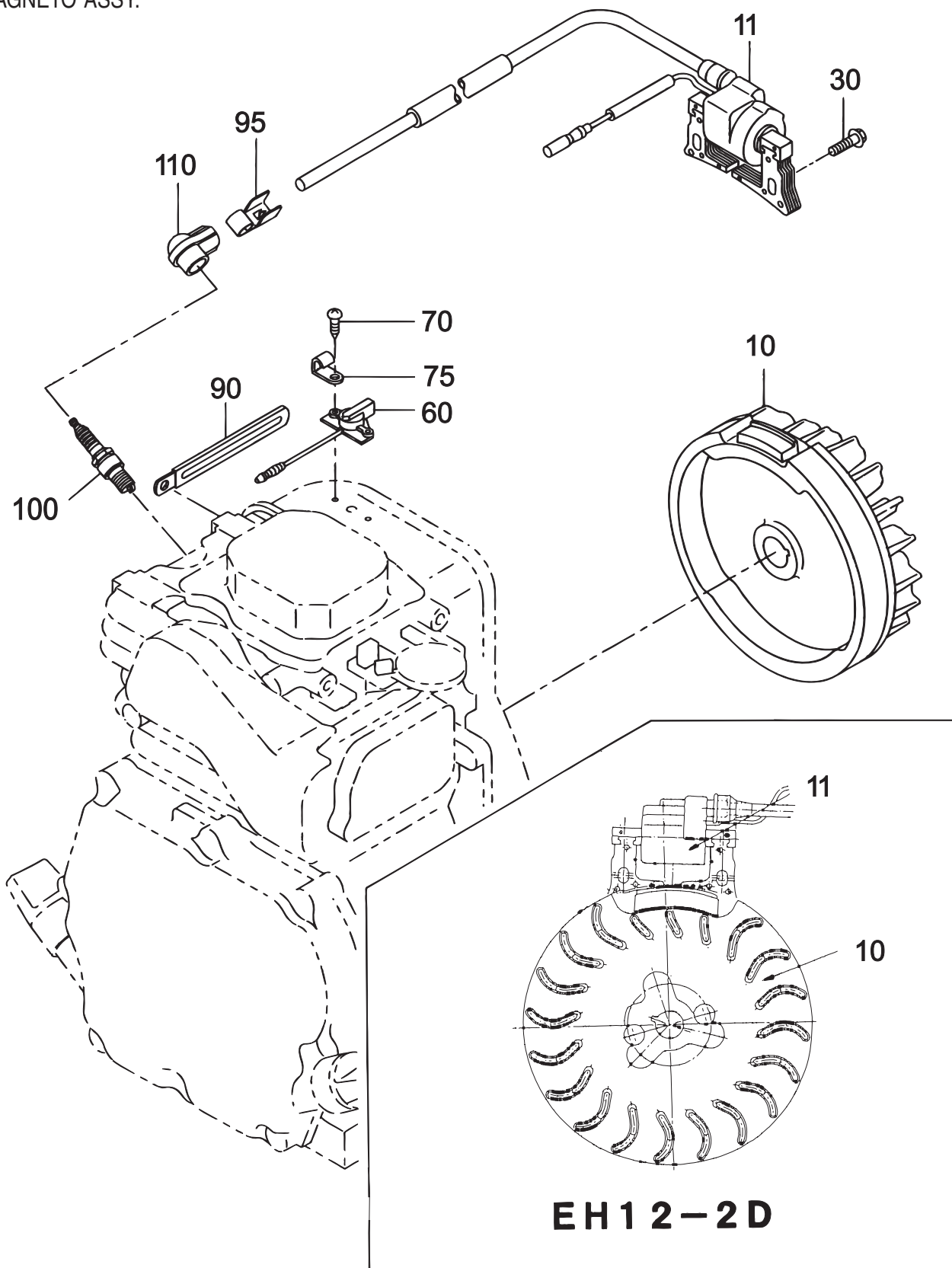

## ROBIN EH-12-2D46420 ENGINE — MAGNETO ASSY.

### MAGNETO ASSY.

<u>NO</u>	<u>PART NO</u>	<u>PART NAME</u>	<u>QTY.</u>	<u>REMARKS</u>
10	2687933201	FLYWHEEL CP	1	
11	2697943011	IGNITION COIL CP	1	
30	0011406250	BOLT & WASHER ASSY	2	
60	0660000371	STOP SWITCH ASSY (ON-OFF)	1	
70	0150040090	TAPPING SCREW	2	
75	0566030010	CLAMP	1	
90	0566000250	CLAMP	1	
95	0659000010	SPARK PLUG CLIP	1	
100	0650140580	SPARK PLUG, BR6ES	1	
110	2307510113	SPARK PLUG CAP	1	

# ROBIN EH-12-2D46420 ENGINE — CARBURETOR ASSY.

CARBURETOR ASSY.

210 252-62570-00

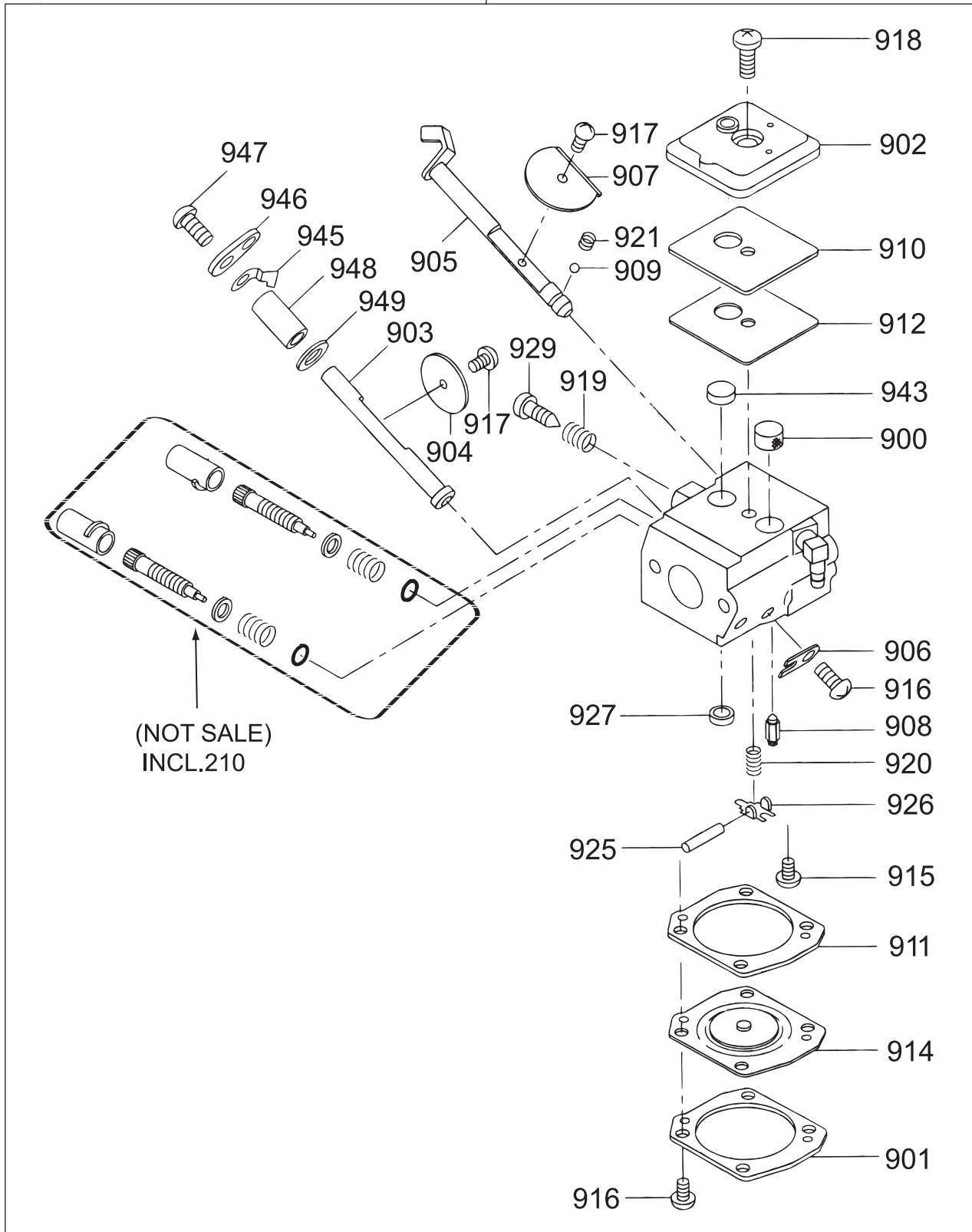



# ROBIN EH-12-2D46420 ENGINE — CARBURETOR ASSY.

## CARBURETOR ASSY.

<u>NO</u>	<u>PART NO</u>	<u>PART NAME</u>	<u>QTY.</u>	<u>REMARKS</u>
210	2526257000	CARBURETOR ASSY. ....	1	INCLUDES ITEMS W/ *
900*	5016004010	SCREEN INLET	1	
901*	2526260508	COVER, METALLING DIAPHRAGM	1	
902*	2526260408	COVER PUMP	1	
903*	2526261208	THROTTLE SHAFT	1	
904*	1616233508	VALVE THROTTLE	1	
905*	2846260308	SHAFT ASSY CHOKE	1	
906*	5106045040	CLIP	1	
907*	2846260408	VALVE, CHOKE	1	
908*	1616255208	VALVE, INLET NEEDLE	1	
909*	1476258408	BALL	1	
910*	1616238008	GASKET PLUG	1	
911*	1616238108	GASKET, METALLING DIAPHRAGM	1	
912*	2526261008	DIAPHRAGM PUMP	1	
914*	1616238308	DIAPHRAGM ASSY, METALLING	1	
915*	1066257508	SCREW	1	
916*	1066257608	SCREW ASSY	5	
917*	1476257308	SCREW	2	
918*	2846260008	SCREW	1	
919*	1616245408	SPRING, IDLE ADJUST	1	
920*	1616245108	SPRING, METALLING LEVER	1	
921*	1476258308	SPRING, CHOKE	1	
925*	1616236808	PIN, METALLING LEVER	1	
926*	1616236908	LEVER, METALLING	1	
927*	1476257508	PLUG	1	
929*	1616238508	SCREW, IDLE ADJUST	1	
943*	2526261108	SPRING PUMP	1	
945*	1616255108	STOPPER, THROTTLE	1	
946*	2526260308	LEVER, THROTTLE	1	
947*	1616255308	SCREW VALVE	2	
948*	2526260208	SPACER, THROTTLE LEVER	1	
949*	2526260108	WASHER	1	

# TERMS AND CONDITIONS OF SALE — PARTS

## PAYMENT TERMS

Terms of payment for parts are net 30 days.

## FREIGHT POLICY

All parts orders will be shipped collect or prepaid with the charges added to the invoice. All shipments are F.O.B. point of origin. Multiquip's responsibility ceases when a signed manifest has been obtained from the carrier, and any claim for shortage or damage must be settled between the consignee and the carrier.

## MINIMUM ORDER

The minimum charge for orders from Multiquip is \$15.00 net. Customers will be asked for instructions regarding handling of orders not meeting this requirement.

## RETURNED GOODS POLICY

Return shipments will be accepted and credit will be allowed, subject to the following provisions:

1. A Returned Material Authorization must be approved by Multiquip prior to shipment.
2. To obtain a Return Material Authorization, a list must be provided to Multiquip Parts Sales that defines item numbers, quantities, and descriptions of the items to be returned.
  - a. The parts numbers and descriptions must match the current parts price list.
  - b. The list must be typed or computer generated.
  - c. The list must state the reason(s) for the return.
  - d. The list must reference the sales order(s) or invoice(s) under which the items were originally purchased.
  - e. The list must include the name and phone number of the person requesting the RMA.
3. A copy of the Return Material Authorization must accompany the return shipment.
4. Freight is at the sender's expense. All parts must be returned freight prepaid to Multiquip's designated receiving point.

5. Parts must be in new and resalable condition, in the original Multiquip package (if any), and with Multiquip part numbers clearly marked.
6. The following items are not returnable:
  - a. Obsolete parts. (If an item is in the price book and shows as being replaced by another item, it is obsolete.)
  - b. Any parts with a limited shelf life (such as gaskets, seals, "O" rings, and other rubber parts) that were purchased more than six months prior to the return date.
  - c. Any line item with an extended dealer net price of less than \$5.00.
  - d. Special order items.
  - e. Electrical components.
  - f. Paint, chemicals, and lubricants.
  - g. Decals and paper products.
  - h. Items purchased in kits.
7. The sender will be notified of any material received that is not acceptable.
8. Such material will be held for five working days from notification, pending instructions. If a reply is not received within five days, the material will be returned to the sender at his expense.
9. Credit on returned parts will be issued at dealer net price at time of the original purchase, less a 15% restocking charge.
10. In cases where an item is accepted, for which the original purchase document can not be determined, the price will be based on the list price that was effective twelve months prior to the RMA date.
11. Credit issued will be applied to future purchases only.

## PRICING AND REBATES

Prices are subject to change without prior notice. Price changes are effective on a specific date and all orders received on or after that date will be billed at the revised price. Rebates for price declines and added charges for price increases will not be made for stock on hand at the time of any price change.

Multiquip reserves the right to quote and sell direct to Government agencies, and to Original Equipment Manufacturer accounts who use our products as integral parts of their own products.

## SPECIAL EXPEDITING SERVICE

A \$35.00 surcharge will be added to the invoice for special handling including bus shipments, insured parcel post or in cases where Multiquip must personally deliver the parts to the carrier.

## LIMITATIONS OF SELLER'S LIABILITY

Multiquip shall not be liable hereunder for damages in excess of the purchase price of the item with respect to which damages are claimed, and in no event shall Multiquip be liable for loss of profit or good will or for any other special, consequential or incidental damages.

## LIMITATION OF WARRANTIES

No warranties, express or implied, are made in connection with the sale of parts or trade accessories nor as to any engine not manufactured by Multiquip. Such warranties made in connection with the sale of new, complete units are made exclusively by a statement of warranty packaged with such units, and Multiquip neither assumes nor authorizes any person to assume for it any other obligation or liability whatever in connection with the sale of its products. Apart from such written statement of warranty, there are no warranties, express, implied or statutory, which extend beyond the description of the products on the face hereof.

Effective: February 22, 2006



# OPERATION & PARTS MANUAL

## HERE'S HOW TO GET HELP

PLEASE HAVE THE MODEL AND SERIAL  
NUMBER *ON-HAND* WHEN CALLING

### UNITED STATES

#### ***Multiquip Corporate Office***

18910 Wilmington Ave. Tel. (800) 421-1244  
Carson, CA 90746 Fax (800) 537-3927  
Contact: mq@multiquip.com

#### ***Mayco Parts***

800-306-2926 Fax: 800-672-7877  
310-537-3700 Fax: 310-637-3284

#### ***Service Department***

800-421-1244 Fax: 310-537-4259  
310-537-3700

#### ***MQ Parts Department***

800-427-1244 Fax: 800-672-7877  
310-537-3700 Fax: 310-637-3284

#### ***Warranty Department***

800-421-1244, Ext. 279 Fax: 310-537-1173  
310-537-3700, Ext. 279

#### ***Technical Assistance***

800-478-1244 Fax: 310-631-5032

### MEXICO

#### ***MQ Cipsa***

Carr. Fed. Mexico-Puebla KM 126.5 Tel: (52) 222-225-9900  
Momoxpan, Cholula, Puebla 72760 Mexico Fax: (52) 222-285-0420  
Contact: pmastretta@cipsa.com.mx

### CANADA

#### ***Multiquip***

4110 Industriel Boul. Tel: (450) 625-2244  
Laval, Quebec, Canada H7L 6V3 Fax: (450) 625-8664  
Contact: jmartin@multiquip.com

### UNITED KINGDOM

#### ***Multiquip (UK) Limited Head Office***

Hanover Mill, Fitzroy Street, Tel: 0161 339 2223  
Ashton-under-Lyne, Fax: 0161 339 3226  
Lancashire OL7 0TL  
Contact: sales@multiquip.co.uk

### BRAZIL

#### ***Multiquip***

Av. Evandro Lins e Silva, 840 - grupo 505 Tel: 011-55-21-3433-9055  
Barra de Tijuca - Rio de Janeiro Fax: 011-55-21-3433-9055  
Contact: cnavarro@multiquip.com.br, srentes@multiquip.com.br

© COPYRIGHT 2007, MULTIQUIP INC.

Multiquip Inc, the MQ logo and the Mikasa logo are registered trademarks of Multiquip Inc. and may not be used, reproduced, or altered without written permission. All other trademarks are the property of their respective owners and used with permission.

This manual **MUST** accompany the equipment at all times. This manual is considered a permanent part of the equipment and should remain with the unit if resold.

The information and specifications included in this publication were in effect at the time of approval for printing. Illustrations, descriptions, references and technical data contained in this manual are for guidance only and may not be considered as binding. Multiquip Inc. reserves the right to discontinue or change specifications, design or the information published in this publication at any time without notice and without incurring any obligations.

Your Local Dealer is:



## Free Manuals Download Website

<http://myh66.com>

<http://usermanuals.us>

<http://www.somanuals.com>

<http://www.4manuals.cc>

<http://www.manual-lib.com>

<http://www.404manual.com>

<http://www.luxmanual.com>

<http://aubethermostatmanual.com>

Golf course search by state

<http://golfingnear.com>

Email search by domain

<http://emailbydomain.com>

Auto manuals search

<http://auto.somanuals.com>

TV manuals search

<http://tv.somanuals.com>