

# OPERATION AND PARTS MANUAL



*Mikasa* SERIES  
**MODEL MVC-70E/EW**  
**ONE-WAY PLATE COMPACTOR**  
**(ROBIN GASOLINE ENGINE)**

Revision #0 (01/25/06)

To find the latest revision of this  
publication, visit our website at:  
[www.multiquip.com](http://www.multiquip.com)



**THIS MANUAL MUST ACCOMPANY THE EQUIPMENT AT ALL TIMES.**



# WARNING



## **CALIFORNIA — Proposition 65 Warning**

Engine exhaust and some of its constituents are known to the State of California to cause cancer, birth defects and other reproductive harm.



**Multiquip MVC-70E/EW  
Plate Compactor**

Proposition 65 Warning ..... 2  
 Table Of Contents ..... 4  
 Parts Ordering Procedures ..... 5  
 Specifications ..... 6  
 Dimensions ..... 7  
 Safety Message Alert Symbols ..... 8-9  
 Rules For Safe Operation.....10-11  
 Operation and Safety Decals ..... 12  
 General Information ..... 13  
 Components (Plate Compactor) ..... 14  
 Components (Engine) ..... 15  
 Inspection ..... 16-17  
 Initial Start-Up ..... 18-19  
 Operation ..... 20  
 Maintenance ..... 21-22  
 Preparation For Long Term Storage ..... 23  
 Troubleshooting (Engine) ..... 24-25  
 Troubleshooting (Plate Compactor) ..... 26  
 Explanation Of Codes In Remarks Column ..... 28  
 Suggested Spare Parts ..... 29

**Component Drawings**

Name Plate and Decals ..... 30-31  
 Main Body Assembly ..... 32-33  
 Vibrator Assembly ..... 34-35  
 Water Tank ..... 36-37

**ROBIN EX170D40050  
Engine**

Air Cleaner Assembly ..... 38-39  
 Camshaft Assembly ..... 40-41  
 Carburetor Assembly ..... 42-43  
 Crankcase Assembly ..... 44-45  
 Crankshaft and Piston Assembly ..... 46-47  
 Cylinder Head Assembly ..... 48-49  
 Fuel Tank Assembly ..... 50-51  
 Governor Assembly ..... 52-53  
 Ignition and Flywheel Assembly ..... 54-55  
 Muffler Assembly ..... 56-57  
 Recoil Starter ..... 58-59

Terms and Conditions Of Sale — Parts ..... 60

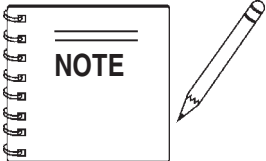

*Specification and part number are subject to change without notice.*

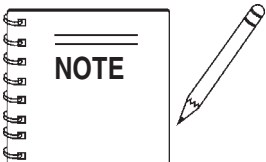

*As a continuing effort to update our parts book, contact the MULTIQIP literature department for the latest revision of your "Operation and Parts Manual"*

www.multiquip.com

**Ordering parts has never been easier!  
Choose from three easy options:**



**Order via Internet (Dealers Only):**

Order parts on-line using Multiquip's SmartEquip website!

- View Parts Diagrams
- Order Parts
- Print Specification Information



If you have an MQ Account, to obtain a Username and Password, E-mail us at: **parts@multiquip.com**.

To obtain an MQ Account, contact your District Sales Manager for more information.

Goto [www.multiquip.com](http://www.multiquip.com) and click on **Order Parts** to log in and save!

Use the **internet** and qualify for a **5% Discount** on *Standard orders* for all orders which include complete part numbers.\*

Note: Discounts Are Subject To Change



**Order via Fax (Dealers Only):**

All customers are welcome to order parts via Fax.

**Domestic (US) Customers dial:**  
1-800-6-PARTS-7 (800-672-7877)

**Fax** your order in and qualify for a **3% Discount** on *Standard orders* for all orders which include complete part numbers.\*

Note: Discounts Are Subject To Change



**Order via Phone: Domestic (US) Dealers Call:**  
1-800-427-1244

**Non-Dealer Customers:**

Contact your local Multiquip Dealer for parts or call 800-427-1244 for help in locating a dealer near you.



**International Customers** should contact their local Multiquip Representatives for Parts Ordering information.

**When ordering parts, please supply:**

- |  |  |
|--|--|
| <ul style="list-style-type: none"> <li><input type="checkbox"/> Dealer Account Number</li> <li><input type="checkbox"/> Dealer Name and Address</li> <li><input type="checkbox"/> Shipping Address (if different than billing address)</li> <li><input type="checkbox"/> Return Fax Number</li> <li><input type="checkbox"/> Applicable Model Number</li> <li><input type="checkbox"/> Quantity, Part Number and Description of Each Part</li> </ul> | <ul style="list-style-type: none"> <li><input type="checkbox"/> Specify Preferred Method of Shipment:                     <ul style="list-style-type: none"> <li><input checked="" type="checkbox"/> Fed Ex/UPS <input checked="" type="checkbox"/> DHL</li> <li><input type="checkbox"/> Priority One <input checked="" type="checkbox"/> Truck</li> <li><input type="checkbox"/> Ground</li> <li><input type="checkbox"/> Next Day</li> <li><input type="checkbox"/> Second/Third Day</li> </ul> </li> </ul> |
|--|--|

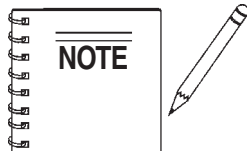

Unless otherwise indicated by customer, all orders are treated as *Standard Orders* and will ship within 24 hours. We will make every effort to ship *Air Shipments* the same day the order is received, if received prior to 2PM PST. *Stock Orders* must be noted on fax or web order form.

**WE ACCEPT ALL MAJOR CREDIT CARDS!**



# MVC-70E/EW— SPECIFICATIONS

## TABLE 1. COMPACTOR SPECIFICATIONS

Model	MVC-70E/W
Centrifugal Force	1,220 kg (2,700 lbs.)
Vibration Frequency	5,600 vpm (93 Hz)
Maximum Forward Speed	25 m/min (82 ft/min)
Plate Size (L x W)	541 x 350 mm (21.3 x 13.8 in )
Overall Dimensions (L x W x H)	879 x 350 x 886 mm (4.6 x 13.8 x 34.9 in )
Operating Weight (with water tank)	86 kg (190 lbs.)
Operating Weight (without water tank)	76 kg (168 lbs.)
Maximum Area of Compaction	543 sq. m/hr (5,865 sq. ft/hr)
Water Tank Capacity (Option)	10 liters (2.64 gallons)

## Table 2. ENGINE SPECIFICATIONS

<b>Engine</b>	<b>Model</b>	<b>ROBIN EX170D40050</b>
	Type	Air-cooled 4 stroke, Single Cylinder, Overhead Camshaft Gasoline Engine
	Displacement	169 cc.
	Max Output	5.7 H.P./4,000 R.P.M.
	Continuous Output	4.0 H.P./3,600 R.P.M.
	Fuel Tank Capacity	Approx. .95 U.S. gallons (3.6 liters)
	Fuel	Unleaded Automobile Gasoline
	Lube Oil Capacity	.634 qts. (0.6 liters)
	Spark Plug	NGK BR-6HS (Champion RL86C)
<b>Dimension (L x W x H)</b>	11.97 x 13.94 x 13.19 in. (304 x 354 x 335 mm)	
<b>Dry Net Weight</b>	33 lbs. (15 Kg.)	

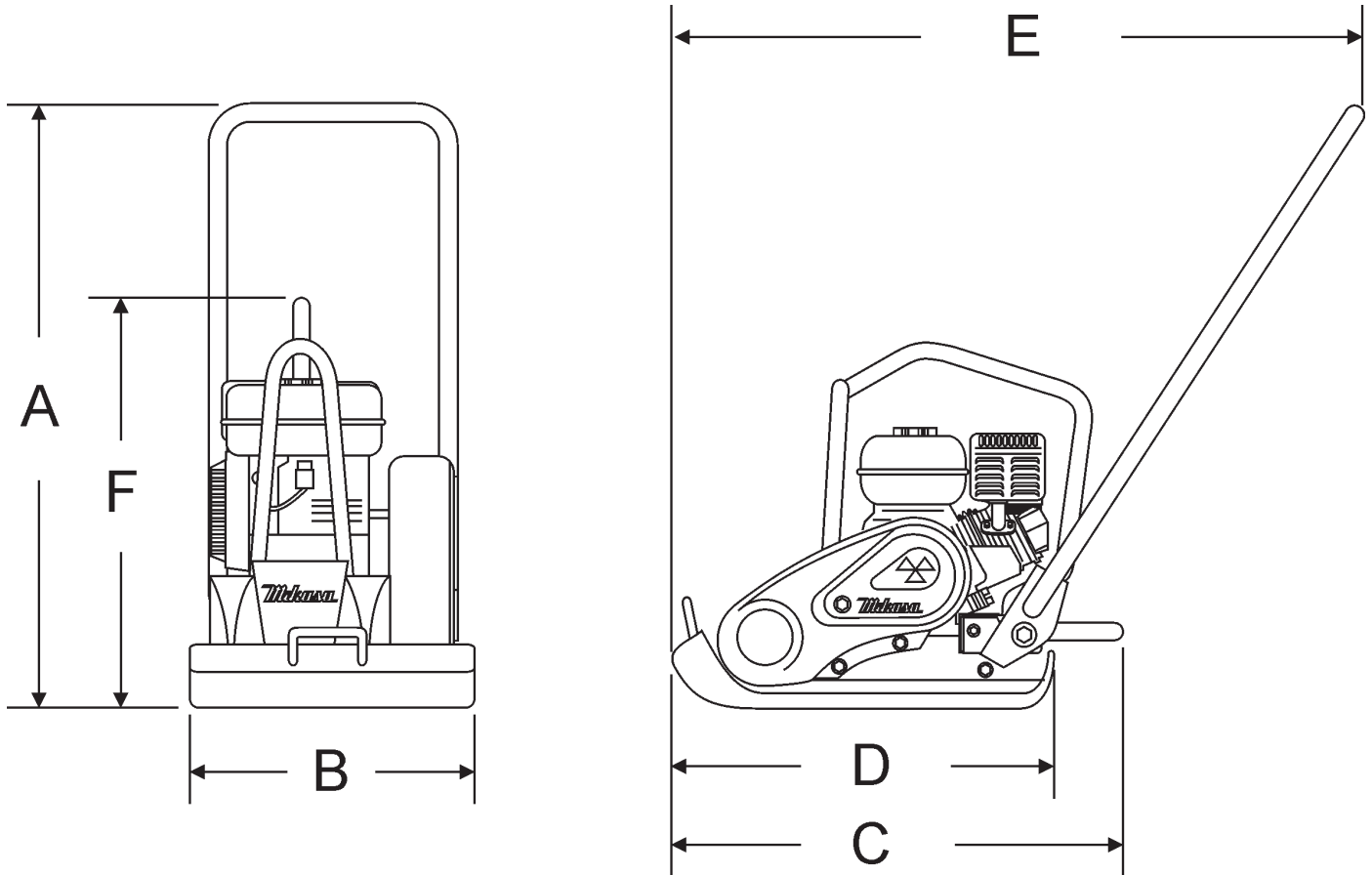

TABLE 3. DIMENSIONS		
REFERENCE LETTER	DESCRIPTION	DIMENSION in. (mm)
A	Height (Handle Upright)	914 mm (36 in.)
B	Width	420 mm (16.5 in.)
C	Length (Handle Upright)	635 mm (25 in.)
D	Plate Length	510 mm (20 in.)
E	Length (Handle Lowered)	914 mm (36 in.)
F	Height (Compactor Only)	635 mm (25 in.)
	Shipping Dimensions	686 x 381 x 711 mm ( 27 x 15 x 28 in.)

Figure 1. MVC-70E/EW Plate Compactor Dimensions

# MVC-70E/EW— SAFETY MESSAGE ALERT SYMBOLS

## FOR YOUR SAFETY AND THE SAFETY OF OTHERS!

Safety precautions should be followed at all times when operating this equipment. Failure to read and understand the Safety Messages and Operating Instructions could result in injury to yourself and others.

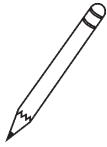
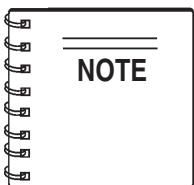

This Owner's Manual has been developed to provide complete instructions for the safe and efficient operation of the Multiquip Plate Compactor MVC-70E/EW. Refer to the

engine manufacturer's instructions for data relative to its safe operation.

**Before using this plate compactor, ensure that the operating individual has read and understands all instructions in this manual.**

## SAFETY MESSAGE ALERT SYMBOLS

The three (3) Safety Messages shown below will inform you about potential hazards that could injure you or others. The Safety Messages specifically address the level of exposure to the operator, and are preceded by one of three words: **DANGER**, **WARNING**, or **CAUTION**.

### DANGER

You **WILL** be **KILLED** or **SERIOUSLY** injured if you **DO NOT** follow directions.

### WARNING

You **CAN** be **KILLED** or **SERIOUSLY** injured if you **DO NOT** follow directions.

### CAUTION

You **CAN** be **INJURED** if you **DO NOT** follow directions.

Potential hazards associated with the operation of an **MVC-70E/EW Plate Compactor** will be referenced with Hazard Symbols which appear throughout this manual, and will be referenced in conjunction with Safety Message Alert Symbols.

## HAZARD SYMBOLS

### WARNING - Lethal Exhaust Gasses

Engine exhaust gases contain poisonous carbon monoxide. This gas is colorless and odorless, and can cause death if inhaled. **NEVER** operate this equipment in a confined area or enclosed structure that does not provide ample free flow air.



### WARNING - Explosive Fuel

**Gasoline** is extremely flammable, and its vapors can cause an explosion if ignited. **DO NOT** start the engine near spilled fuel or combustible fluids.



**DO NOT** fill the fuel tank while the engine is running or hot. **DO NOT** overfill tank, since spilled fuel could ignite if it comes into contact with hot engine parts or sparks from the ignition system. Store fuel in approved containers, in well-ventilated areas and away from sparks and flames.

### WARNING - Burn Hazards

Engine components can generate extreme heat. To prevent burns, **DO NOT** touch these areas while the engine is running or immediately after operations. Never operate the engine with heat shields or heat guards removed.



### CAUTION - Respiratory Hazard

**ALWAYS** wear approved **respiratory** protection when required.





# MVC-70E/EW— SAFETY MESSAGE ALERT SYMBOLS

## ! CAUTION - Rotating Parts

**NEVER** operate equipment with covers, or guards removed. Keep fingers, hands, hair and clothing away from all moving parts to prevent injury.



## ! CAUTION - Equipment Damage Messages

Other important messages are provided throughout this manual to help prevent damage to your plate compactor, other property, or the surrounding environment.

## ! CAUTION - Accidental Starting

**ALWAYS** place the power source, circuit breakers or **ON/OFF** switch in the **OFF** position, when the generator is not in use, unless connected to transfer switch.

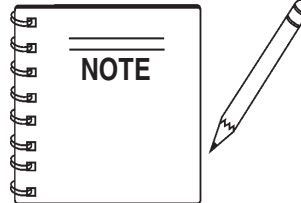

This plate compactor, other property, or the surrounding environment could be damaged if you do not follow instructions.

## ! CAUTION - Sight and Hearing Hazards

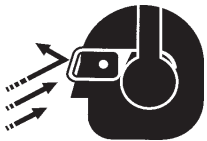

**ALWAYS** wear approved eye and hearing protection.

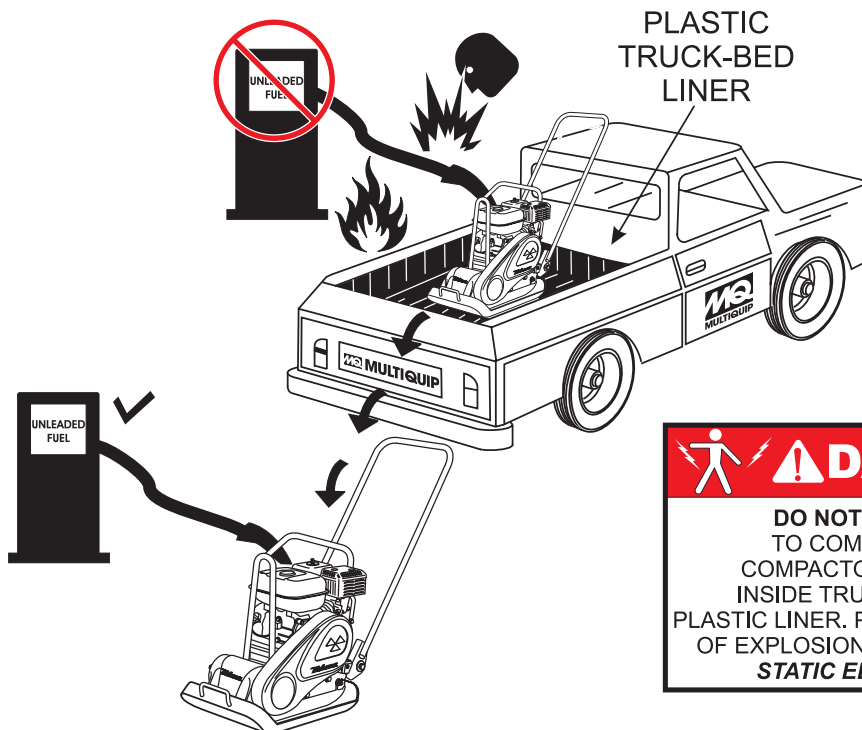

**! DANGER**  
**DO NOT ADD FUEL TO COMPACTOR IF COMPACTOR IS PLACED INSIDE TRUCK-BED WITH PLASTIC LINER. POSSIBILITY EXISTS OF EXPLOSION OR FIRE DUE TO STATIC ELECTRICITY.**

# MVC-70E/EW — RULES FOR SAFE OPERATION

## CAUTION - Read Manual!

Failure to follow instructions in this manual may lead to serious injury or even death! This equipment is to be operated by trained and qualified personnel only! This equipment is for industrial use only.



The following safety guidelines should always be used when operating the **MQ Mikasa Model MVC-70E/EW Plate Compactor**.

### GENERAL SAFETY

- **DO NOT** operate or service this equipment before reading this entire manual.
- This equipment should not be operated by persons under 18 years of age.
- **NEVER** operate this equipment without proper protective clothing, shatterproof glasses, steel-toed boots and other protective devices required by the job.



- **NEVER** operate this equipment when not feeling well due to fatigue, illness or taking medicine.



- **NEVER** operate this equipment under the influence of **drugs** or **alcohol**.



- **NEVER** touch the hot exhaust manifold, muffler or cylinder. Allow these parts to cool before servicing engine or mixer.

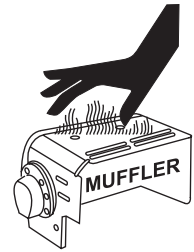

- **High Temperatures** – Allow the engine to cool before adding fuel or performing service and maintenance functions. Contact with **hot!** components can cause serious burns.

- The engine section of this mixer requires an adequate free flow of cooling air. **NEVER** operate the compactor in any enclosed or narrow area where free flow of the air is restricted. If the air flow is restricted it will cause serious damage to the compactor or engine and may cause injury to people. Remember the plate compactor's engine gives off **DEADLY** carbon monoxide gas.

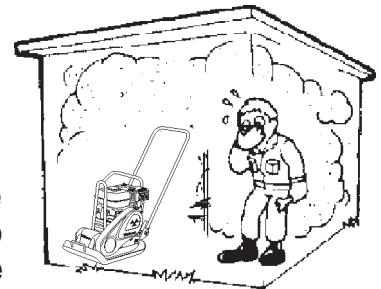

- **ALWAYS** refuel in a well-ventilated area, away from sparks and open flames.

- **ALWAYS** use extreme caution when working with **flammable** liquids. When refueling, **stop the engine** and allow it to cool. **DO NOT smoke** around or near the machine. Fire or explosion could result from fuel vapors, or if fuel is spilled on a hot engine.



- **NEVER** operate the plate compactor in an explosive atmosphere or near combustible materials. An explosion or fire could result causing severe **bodily harm or even death**.



- Topping-off to filler port is dangerous, as it tends to spill fuel.
- Maintain this equipment in a safe operating condition at all times.
- **ALWAYS** store equipment properly when it is not being used. Equipment should be stored in a clean, dry location out of the reach of children.

# MVC-70E/EW— RULES FOR SAFE OPERATION

- **NEVER** run engine without air filter. Severe engine damage may occur.
- **ALWAYS** service air cleaner frequently to prevent carburetor malfunction.
- **ALWAYS** be sure the operator is familiar with proper safety precautions and operations techniques before using compactor.
- **ALWAYS** read, understand, and follow procedures in Operator's Manual before attempting to operate equipment.
- Refer to the *Robin Engine Owner's Manual* for engine technical questions or information.

## Loading and Unloading (Crane)

- Before lifting, make sure that machine parts (lifting bale and vibration insulator) are not damaged and screws are not loosened or lost.
- **ALWAYS** make sure crane or lifting device has been properly secured to the lifting bale on the compactor.



- **NEVER** lift the compactor while the engine is running.
- Use adequate lifting cable (wire or rope) of sufficient strength.
- Use one point suspension hook and lift straight upwards.
- **NEVER** allow any person or animal to stand underneath the machine while lifting.
- Try not to lift compactor to unnecessary heights.

## TRANSPORTING

- **ALWAYS** shutdown engine before transporting.
- Tighten fuel tank cap securely and close fuel cock to prevent fuel from spilling.
- Drain fuel when transporting compactor over long distances or bad roads.

## MAINTENANCE

- **NEVER** lubricate components or attempt service on a running compactor.
- **ALWAYS** allow the plate compactor a proper amount of time to cool before servicing.
- Keep the compactor in proper running condition.
- Fix damage to the plate compactor immediately and always replace broken parts.
- Dispose of hazardous waste properly. Examples of potentially hazardous waste are used motor oil, fuel and fuel filters.
- **DO NOT** use food or plastic containers to dispose of hazardous waste.

## EMERGENCIES

- **ALWAYS** know the location of the nearest *fire extinguisher* and *first aid kit*.



- In emergencies *always* know the location of the nearest phone or *keep a phone on the job site*. Also know the phone numbers of the nearest *ambulance*, *doctor* and *fire department*. This information will be invaluable in the case of an emergency.



# MVC-70E/EW— OPERATION AND SAFETY DECALS

## Machine Safety Decals

The MVC-70E/WPlate Compactor is equipped with a number of safety decals (Figure 2). These decals are provided for operator safety and maintenance information. The illustration below shows these decals as they appear on the machine. Should any of these decals become unreadable, replacements can be obtained from your dealer.

**CAUTION !**

- READ OWNER'S SERVICE MANUAL BEFORE OPERATING OR SERVICING THIS MACHINE.
- ALWAYS KEEP UNAUTHORIZED, INEXPERIENCED, UNTRAINED PEOPLE AWAY FROM THIS MACHINE.
- MAKE SURE ALL SAFETY DEVICES ARE OPERATIONAL BEFORE THIS MACHINE IS STARTED. BE SURE ENGINE IS TURNED OFF AND SPARK PLUGS ARE DISCONNECTED BEFORE SERVICING THE MACHINE OR COMING IN CONTACT WITH ANY MOVING PART. IF EQUIPMENT IS POWERED BY AN ELECTRIC MOTOR, DISCONNECT ELECTRICAL PLUG.
- NEVER LEAVE MACHINE UNATTENDED WHEN OPERATING. ALWAYS STOP ENGINE AND ALLOW ENGINE TO COOL BEFORE ADDING FUEL OR OIL.

NPA-329 ①

P/N: 920203290

***Mikasa***

Serial No.

Model No.

**MQ MULTQUIP**

**CONTACT  
PARTS DEPT.**

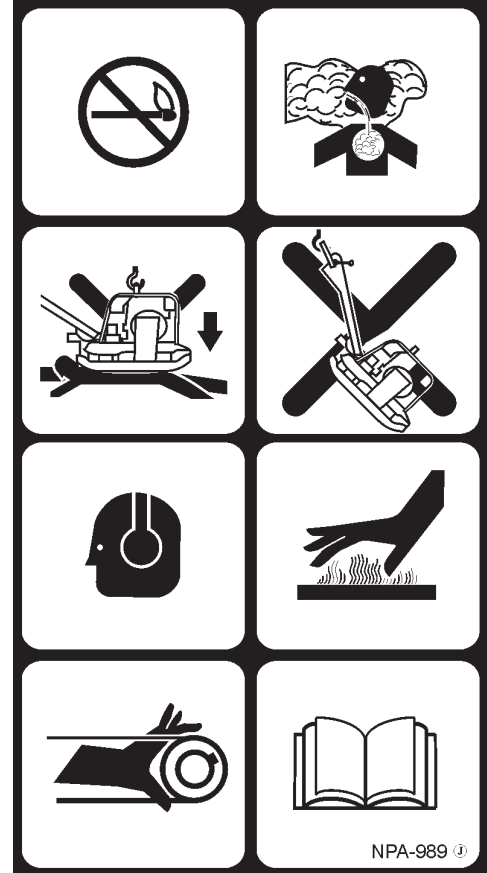

P/N 9202039890

Figure 2. Operation and Safety Decals

# MVC-70E/EW — GENERAL INFORMATION

## Definition of Plate Compactor

The Mikasa MVC-70E/EW is a walk behind, plate compactor designed for the compaction of sand, mixed soils and asphalt. This plate compactor is a powerful compacting tool capable of applying a tremendous force in consecutive high frequency vibrations to a soil surface. Its applications include compacting for road, embankments and reservoirs as well as backfilling for gas pipelines, water pipelines and cable installation work.

The MVC-70E/EW is small and lightweight. It can be easily handled by one person in confined areas. It has an accessible front-mounted vibrator assembly. The sealed belt cover keeps dirt and rocks away from the belt.

## Vibratory Plate

The vibratory plate of the compactor produces low amplitude high frequency vibrations, designed to compact granular soils and asphalt.

The resulting vibrations cause forward motion. The engine and handle are vibration isolated from the vibrating plate.

## Frequency/Speed

The compactor's vibrating plate has a frequency of 5,600 vpm (vibrations per minute). The travel speed of the compactor is approximately 82 ft./minute (25 meters/minute).

## Engine

The Mikasa MVC-70E/EW Plate Compactor is equipped with a ROBIN EX170D40050 gasoline engine.

## Controls

Before starting the MVC-70E/EW Plate Compactor identify and understand the function of the controls and components as indicated Figure 3.

	<b>WARNING</b>
To avoid injuries and damage to the equipment, <b>ALWAYS</b> read and understand contents of operation manual before operating equipment.	

	<b>WARNING</b>
	To avoid injury, you <b>MUST</b> read and understand operator's manual before using this machine.
	This machine to be operated by qualified personnel only. Ask for training as needed.

## MVC-70E/EW — COMPONENTS (PLATE COMPACTOR)

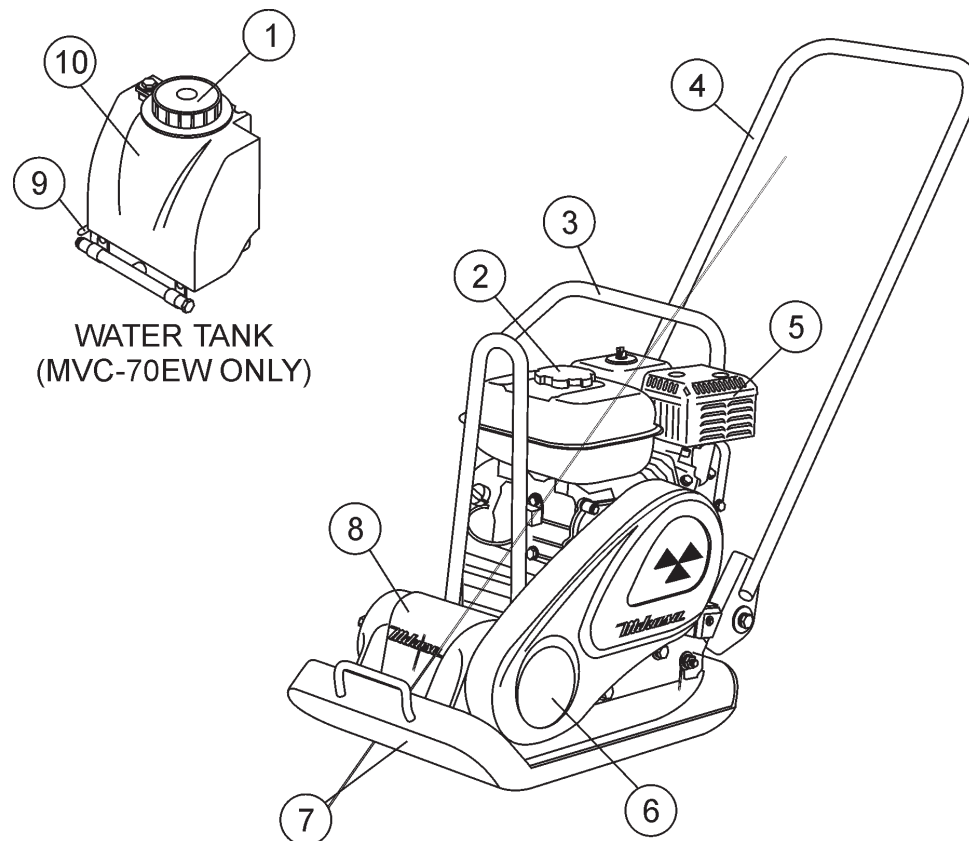

WATER TANK  
(MVC-70EW ONLY)

Figure 3. MVC-70E/EW Plate Compactor Components

Figure 3 shows the location of the components and general maintenance parts. The function of each component is described below:

1. **Water Tank Cap (for MVC-70EW only)** – Remove this cap to add water to the water tank.
2. **Fuel Tank Cap** – Remove this cap to add fuel.
3. **Lifting Bail** – When lifting of the compactor is required either by forklift, crane etc., tie rope or chain around this lifting point.
4. **Handle Bar** – When operating the compactor use this handle bar to maneuver the compactor.
5. **Gasoline Engine** – This plate compactor uses a ROBIN EX170D40050 engine. Refer to the ROBIN owner's manual for engine information.
6. **Belt Cover** – Remove this cover to gain access to the V-belts. **NEVER** run the compactor without the V-belt cover. If the V-belt cover is not installed, the possibility exist that your hand may get caught between the V-belt and clutch, thus causing serious injury and bodily harm.
7. **Vibrating Plate** – A flat, open plate made of durable cast iron construction used in the compacting of soil.
8. **Vibration Case** – Encloses the eccentric, gears and counter weights.
9. **Water Shut-Off Valve (for MVC-70EW only)** – Turn this valve downward to let water flow from the water tank to the water tube.
10. **Water Tank (for MVC-70EW only)** – Holds 10.6 quarts (10 liters) of water, removable no tools required.

# MVC-70E/EW— COMPONENTS (ROBIN EX170D40050 ENGINE)

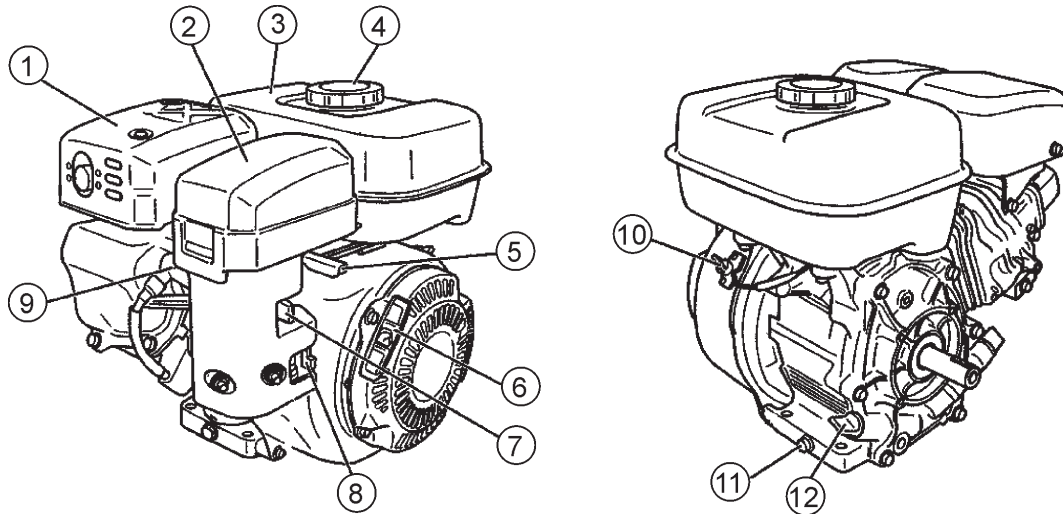

Figure 4. Engine Controls and Components

## INITIAL SERVICING

The engine (Figure 4) must be checked for proper lubrication and filled with fuel prior to operation. Refer to the **ROBIN** engine service manual for instructions and details for proper operation and servicing.

1. **Muffler** – Used to reduce noise and emissions.



### **WARNING**

Engine components can generate extreme heat. To prevent burns, **DO NOT** touch these areas while the engine is running or immediately after operating. **NEVER** operate the engine with the muffler removed.

2. **Air Cleaner** – Prevents dirt and other debris from entering the fuel system. Remove wing-nut on top of air filter canister to gain access to filter element.
3. **Fuel Tank** – Holds unleaded gasoline. For additional information refer to ROBIN engine owner's manual.
4. **Fuel Filler Cap** – Remove this cap to add unleaded gasoline to the fuel tank. Make sure cap is tightened securely. **DO NOT** over fill.



### **DANGER**

Adding fuel to the tank should be done only when the engine is stopped and has had an opportunity to cool down. In the event of a fuel spill, **DO NOT** attempt to start the engine until the fuel residue has been completely wiped up, and the area surrounding the engine is dry.

5. **Throttle Lever** – Used to adjust engine RPM speed (lever advanced forward **SLOW**, lever back toward operator **FAST**).
6. **Recoil Starter (pull rope)** – Manual-starting method. Pull the starter grip until resistance is felt, then pull briskly and smoothly.
7. **Choke Lever** – Used in the starting of a cold engine, or in cold weather conditions. The choke enriches the fuel mixture.
8. **Fuel Valve Lever** – **OPEN** to let fuel flow, **CLOSE** to stop the flow of fuel.
9. **Spark Plug** – Provides spark to the ignition system. Set spark plug gap to 0.6 - 0.7 mm (0.028 - 0.031 inch) Clean spark plug once a week.
10. **Engine ON/OFF Switch** – ON position permits engine starting, OFF position stops engine operations.
11. **Oil Drain Plug** – Remove this plug to drain engine oil from the crankcase.
12. **Oil Dipstick/ Filler Cap** – Remove the filler cap dipstick when checking the engine oil level. Add engine oil through this filler port. See Table 5 for recommended type engine oil.

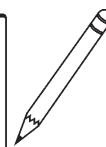
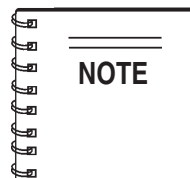

Operating the engine without an air filter, with a damaged air filter, or a filter in need of replacement will allow dirt to enter the engine, causing rapid engine wear.

## Before Starting

1. Read safety instructions at the beginning of manual.
2. Clean the compactor, removing dirt and dust. Particularly, the bottom of the plate, engine cooling air inlet, carburetor and air cleaner.
3. Check the air filter for dirt and dust. If the air filter is dirty, blow through the air filter cartridge from the inside, moving a jet of dry compressed air up and down until all dust is removed. Otherwise replace air filter with a new one.
4. Check carburetor for external dirt and dust. Clean with dry compressed air.
5. Check fastening nuts and bolts for tightness. Loosened screws or bolts due to vibration, could lead to unexpected accident.

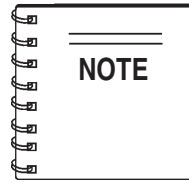

The Oil Alert system will automatically stop the engine before the engine falls below safe limits. Always be sure to check the engine oil level prior to starting the engine.

## Engine Oil Check

1. To check the engine oil level, place the plate compactor on secure level ground with the engine stopped.
2. Remove the filler cap/dipstick from the engine oil filler hole (Figure 5) and wipe it clean.

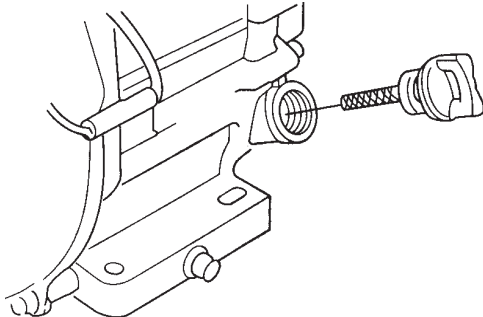

Figure 5. Engine Oil Dipstick

3. Insert and remove the dipstick without screwing it into the filler neck. Check the oil level shown on the dipstick.
4. If the oil level is low (Figure 6), fill to the edge of the oil filler hole with the recommended oil type (Table 4).

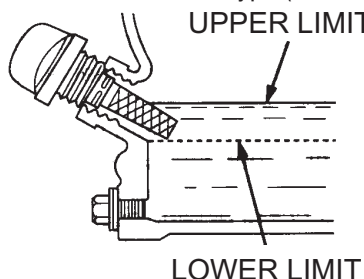

Figure 6. Engine Oil Dipstick

Table 4. Oil Type

Season	Temperature	Oil Type
Summer	25°C or Higher	SAE 10W-30
Spring/Fall	25°C~10°C	SAE 10W-30/20
Winter	0°C or Lower	SAE 10W-10

## Gasoline Check

1. Remove the gasoline cap located on top of fuel tank.
2. Visually inspect to see if fuel level is low. If fuel is low, replenish with unleaded fuel.
3. When refueling, be sure to use a strainer for filtration. **DO NOT** top-off fuel. Wipe up any spilled fuel.

## Vibrator Oil Check

1. Place the MVC-70E/EW plate compactor horizontally on a flat surface. Make sure the compactor is level when checking the oil in the vibrator assembly.
2. Check vibrator oil level by removing the plug (vibrator oil gauge) as shown in Figure 7. The oil level should be up to the oil plug. If oil is required, replace using only SAE 10W-30 motor oil.

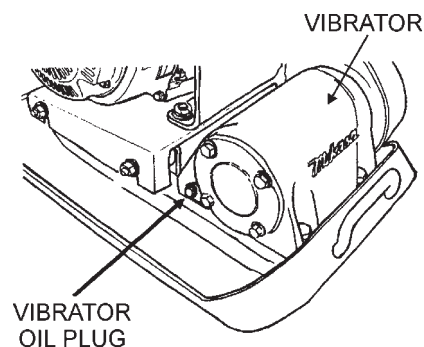

Figure 7. Vibrator Oil Plug



## V-Belt Check

### Caution - V-Belt check

**NEVER** attempt to check the V-belt with the engine running. Severe injury can occur if your hand (Figure 8) gets caught between the V-belt and the clutch. Always use safety gloves.

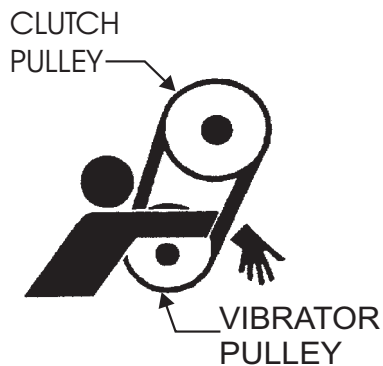

**Figure 8. V-Belt Hazard**

2. The V-belt tension is proper if the V-belt bends 10 to 15 mm (Figure 10) when depressed with finger at midway between the clutch and vibration pulley shafts.

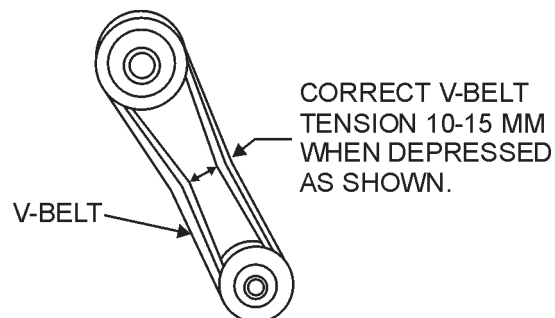

**Figure 10. V-Belt Tension**

3. A loose V-belt will decrease the power transmission output, causing reduced compaction and premature wear of the belt.
4. If the V-belt becomes worn or loose, replace it .

1. To check the V-belt tension, remove the bolts that secure the belt cover to the frame as shown in Figure 9.

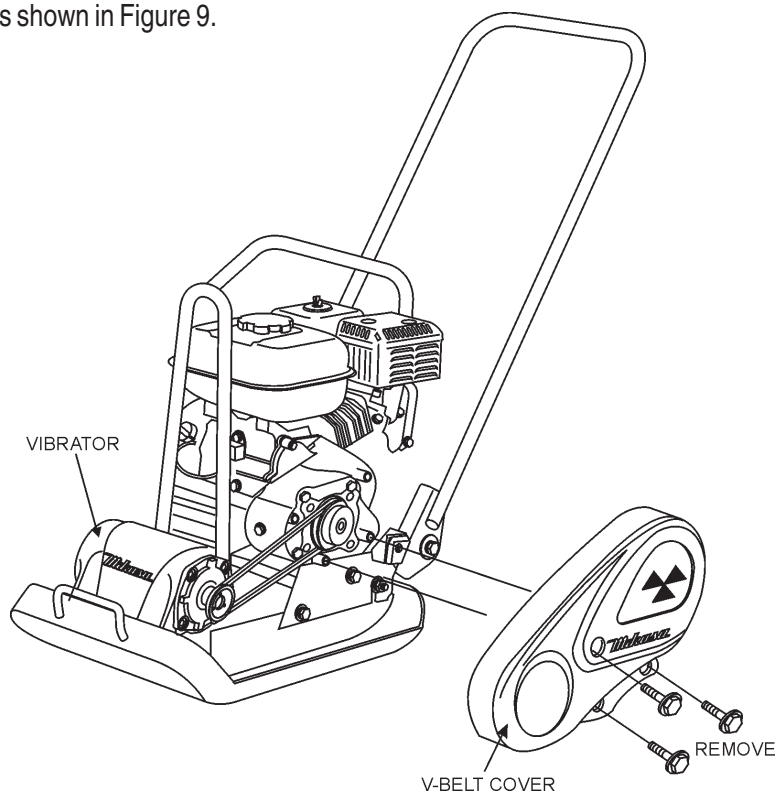

**Figure 9. V-Belt Cover Removal**

## CAUTION - Read Instructions

**DO NOT** attempt to operate the pump until the Safety, General Information and Inspection sections of this manual have been **read and thoroughly understood**.



This section is intended to assist the operator with the **initial start-up** of the trash pump. It is extremely important that this section be read carefully before attempting to use the pump in the field.

### Starting the Engine

1. Place the engine **fuel valve lever** (Figure 11) to the "ON" position.

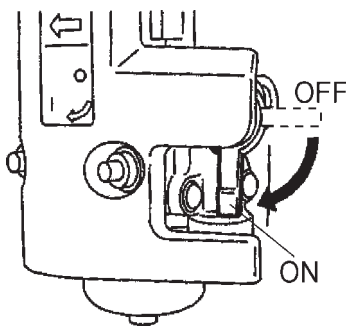

Figure 11. Engine Fuel Valve Lever (ON Position)

2. Move the **throttle lever** (Figure 12) away from the slow position, about 1/3 of the way toward the fast position.

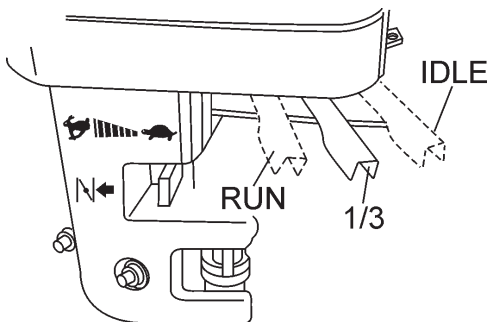

Figure 12. Throttle Lever (1/3 Start Position)

3. Place the **choke lever** (Figure 13) in the "CLOSED" position if starting a **cold** engine.

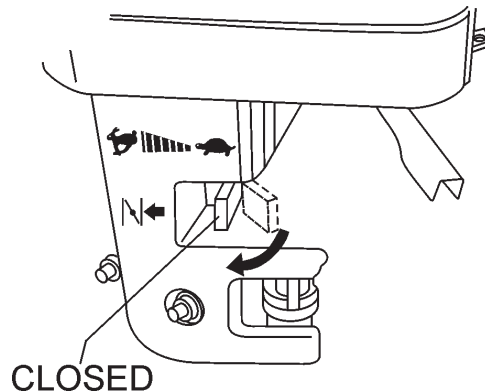

Figure 13. Engine Choke Lever (Closed)

4. Place the **choke lever** (Figure 14) in the "OPEN" position if starting a **warm engine** or the **temperature is warm**.

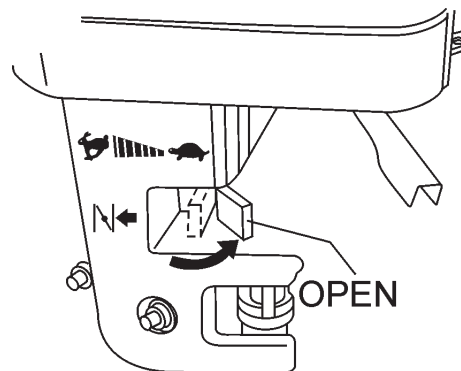

Figure 14. Engine Choke Lever (Open)

5. Place the **engine ON/OFF switch** (Figure 15) in the "ON" position.

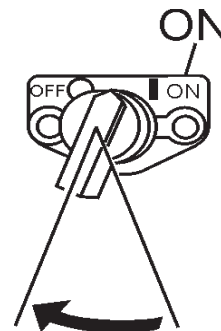

Figure 15. Engine ON/OFF Switch (ON Position)

- Grasp the starter grip (Figure 16) and slowly pull it out. The resistance becomes the hardest at a certain position, corresponding to the compression point. Pull the starter grip briskly and smoothly for starting.

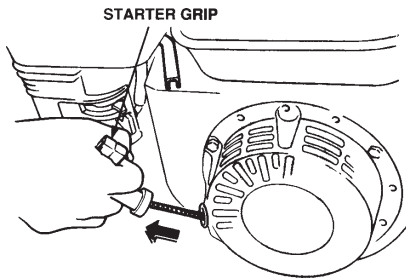

Figure 16. Starter Grip

- If the engine has started, slowly return the choke lever (Figure 17) to the "OPEN" position. If the engine has not started repeat steps 1 through 6.

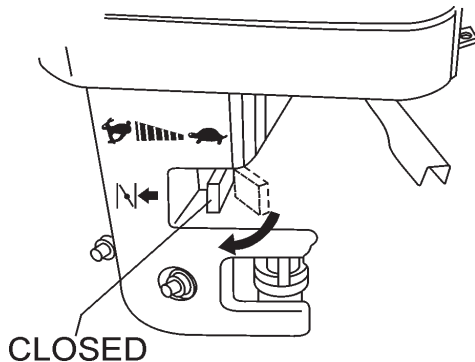

Figure 17. Choke Lever (Open)

- Before the pump is placed into operation, run the engine for several minutes. Check for fuel leaks, and noises that would associate with a loose component.
- To begin pumping, place the throttle lever (Figure 18) in the "RUN" position.

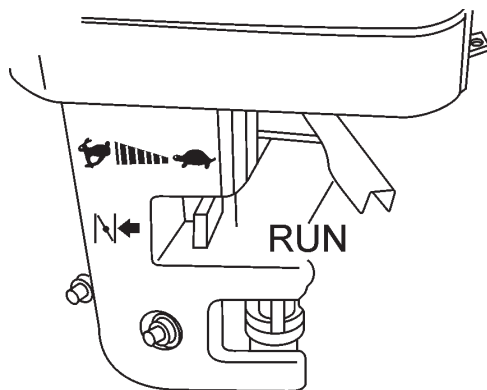

Figure 18. Throttle Lever (Run)

## Stopping The Engine

### Normal Shutdown

- Move the throttle lever to the **IDLE** position (Figure 19) and run the engine for three minutes at low speed.

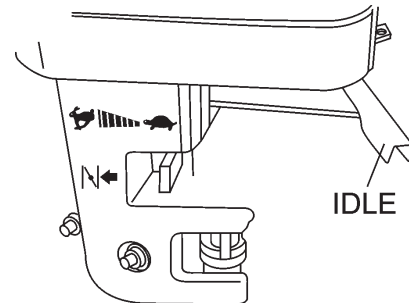

Figure 19. Throttle Lever (Idle)

- After the engine **cools**, turn the engine ON/OFF switch to the "OFF" position (Figure 20).



Figure 20. Engine ON/OFF Switch (OFF)

- Place the **fuel shut-off lever** (Figure 21) in the **OFF** position.

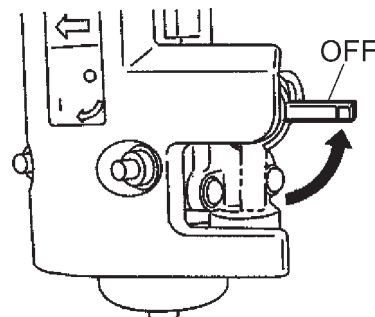

Figure 21. Fuel Valve Lever (OFF)

### Emergency Shutdown

- Move the throttle lever quickly to the **IDLE** position, and place the engine ON/OFF switch in the **OFF** position.

## Operation

### CAUTION - General Operation Safety

Make sure to follow all safety rules referenced in the safety section of this manual before operating compactor. Keep work area clear of debris and other objects that could cause damage to the compactor or bodily injury.

1. Once the engine has started, move the engine throttle lever quickly to the **fast** position.
2. With the throttle lever in the fast position, the engine speed should be around 2,300 RPM, therefore engaging the centrifugal clutch.

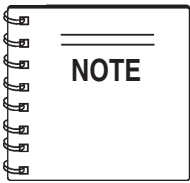

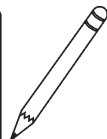
 Always move the throttle lever quickly without hesitation, because increasing the engine speed slowly causes the clutch to slip.

3. Firmly grasp the compactor's handle bar with both hands. The compactor will begin moving forward.
4. Slowly walk behind the compactor and be on the lookout for any large objects or foreign matter that might cause damage to the compactor or bodily injury.

5. Compactor traveling speed may drop on soils which contain clay, however there may be cases where traveling speed drops because the compaction plate does not leave the ground surface easily due to the composition of the soil. To rectify this problem, do the following:

- Check the bottom plate to see if clay or equivalent material has been lodged in the plate mechanism. If so, wash with water and remove.
- Remember the compactor does not work as efficiently on clay or soils that have a high moisture content level.
- If the soil has a high moisture level, dry soil to appropriate moisture content level or carry out compaction twice.

# MVC-70E/EW — MAINTENANCE

## ⚠ CAUTION - General Maintenance Safety

Inspection and other services should **always** be carried out on hard and level ground with the engine shutdown.

## ⚠ CAUTION - Inspection Intervals

These inspection intervals are for operation under normal conditions. Adjust your inspection intervals based on the number hours plate compactor is in use, and particular working conditions.

### Inspection and Maintenance Service Tables.

- To make sure your plate compactor is always in good working condition before using, carry out the maintenance inspection in accordance with Tables 5 and 6.

**TABLE 5. MVH-70E/EW MACHINE INSPECTION**

ITEM	HOURS OF OPERATION	REMARKS
Damaged Parts	Every 8 hours (every day)	
Loose or Lost Screws	Every 8 hours (every day)	
Function of Controlling System Part	Every 8 hours (every day)	
Vibrator Oil Check	Every 100 hours	See page 16
Vibrator Oil Replacement	Every 300 hours	See page 22
V-belt (clutch) Check	Every 200 hours	See page 17

## ⚠ CAUTION - Fuel Piping and Connections

Fuel piping and connections should be replaced every 2 years.

### Daily Service

- Check for leakage of fuel or oil.
- Remove soil and clean the bottom of compaction plate.
- Check engine oil, see page 16.
- Check for loose screws including tightness. See Table 7 below (tightening torque), for retightening:

**TABLE 7.**

### TIGHTENING TORQUE (in. kg/cm) Diameter

Material	6mm	8mm	10mm	12mm	14mm	16mm	18mm	20mm
4T	70	150	300	500	750	1,100	1,400	2,000
6-8T	100	250	500	800	1,300	2,000	2,700	3,800
11T	150	400	800	1,200	2,000	2,900	4,200	5,600
*	100 (6mm) 300 ~ 350 (8mm) 650 ~ 700 (10mm)							
* (In case counter-part is of aluminum)								
(Threads in use with this machine are all right handed)								
Material and quality of material is marked on each bolt, and screw.								

**Table 6. ENGINE MAINTENANCE**

DESCRIPTION (3)	OPERATION	BEFORE	FIRST MONTH OR 10 HRS.	EVERY 3 MONTHS OR 25 HRS.	EVERY 6 MONTHS OR 50 HRS.	EVERY YEAR OR 100 HRS.	EVERY 2 YEARS OR 200 HRS.
Engine Oil	CHECK	X					
	CHANGE		X				
Air Cleaner	CHECK	X					
	CHANGE			X (1)			
All Nuts & Bolts	Re-tighten If Necessary	X					
Spark Plug	CHECK-CLEAN				X		
	REPLACE						X
Cooling Fins	CHECK			X			
Spark Arrester	CLEAN					X	
Fuel Tank	CLEAN					X	
Fuel Filter	CHECK					X	
Idle Speed	CHECK-ADJUST					X (2)	
Valve Clearance	CHECK-ADJUST						X (2)
Fuel lines	CHECK						Every 2 years (replace if necessary) (2)

(1) Service more frequently when used in DUSTY areas.

(2) These items should be serviced by your servic dealer, unless you have the proper tools and are mechanically proficient. Refer to the ROBIN Manual for service procedures

(3) For commercial use, log hours of operation to determine proper maintenance intervals.

### ENGINE OIL

- Drain the engine oil when the oil is **warm** as shown in Figure 22.
- Remove the oil drain bolt and sealing washer and allow the oil to drain into a suitable container.
- Replace engine oil with recommended type oil as listed in Table 4. Engine oil capacity is .634 quarts (.6liters). **DO NOT** overfill.
- Install drain bolt with sealing washer and tighten securely.

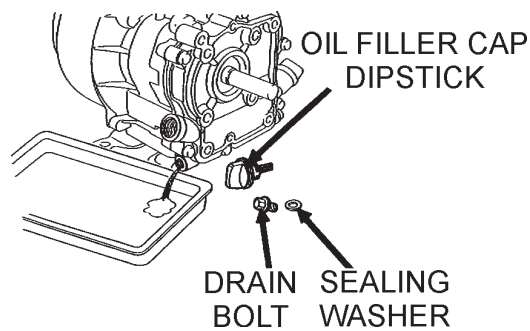

Figure 22. Engine Oil (Draining)

## Spark Plug

1. Remove and clean the spark plug (Figure 23).
2. Adjust the spark gap to 0.028 ~0.031 inch (0.6~0.7 mm). This unit has electronic ignition, which requires no adjustments.

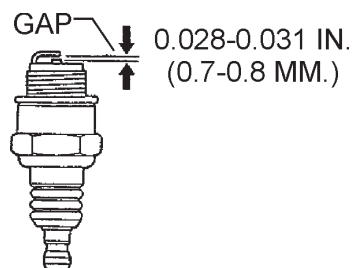

Figure 23. Spark Plug Gap

## Engine Air Cleaner

1. Remove the air cleaner cover and foam filter element as shown in Figure 24.
2. Wash the foam filter element in kerosene or diesel fuel. Then saturate it in a mixture of 3 parts kerosene or diesel fuel and 1 part engine oil. Completely squeeze the element to remove the mixture and re-install it back into the air cleaner.

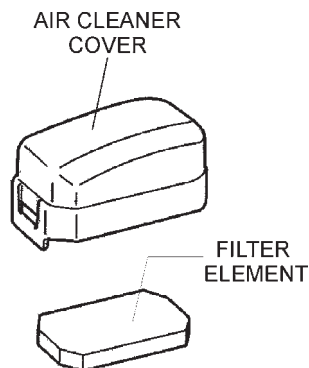

Figure 24. Air Cleaner

## Changing Vibrator Oil

1. When changing the vibrator oil, remove the drain plug (Figure 7), and simply tip the compactor to drain the oil. Note that the oil will drain more easily while it is hot. Remember to use only 10W-30 motor oil when replacing vibrator oil.

## Checking and Replacing the V-Belt and Clutch

1. After 200 hours of operation, remove the upper belt cover to check the V-belt tension. Tension is proper if the belt bends about 10 mm when depressed strongly with finger between shafts. Loose or worn V-belts reduces power transmission efficiency, causing weak compaction and reduces the life of the belt itself.

### ! CAUTION - Checking and Replacing the V-Belt

**NEVER** attempt to check the V-belt with the engine running. Severe injury can occur if your hand gets caught between the V-belt and the clutch. Always use safety gloves.

### ! CAUTION - Checking the V-Belt

Whenever the compactor's vibration becomes weak or lost during normal operation regardless of operation hours, check the V-belt and clutch immediately.

### ● Replacing the V-belt

Remove the upper and lower belt covers. Engage an offset wrench (13 mm) or the like to vibrator pulley (lower) fastening bolt. Engage waste cloth or the like at midway of V-belt on the left side and while pulling it back strongly, rotate the offset wrench clockwise so that the V-belt will come off.

### ● Reinstalling the V-belt

Engage V-belt to lower vibrator pulley and push the V-belt to left side of upper clutch and, in the same manner as in removal, rotate offset wrench clockwise so that the V-belt goes back on.

### ● Checking Clutch

Check the clutch simultaneously with V-belt checking. With belt removed, check outer drum of the clutch for seizure and "V" groove for wear or damage with your eyes. Clean the "V" groove as necessary. Wear of lining or shoe should be checked with running check. If the shoe is worn, power transmission becomes deficient and slipping will result.

# MVC-70E/EW— PREPARATION FOR LONG -TERM STORAGE

## Compactor Storage

For storage of the compactor for over 30 days, the following is required:

- Drain the fuel tank completely.
- Run the engine until the fuel in the injection system is completely consumed.
- Completely drain the oil from the engine crankcase and follow procedures described in the **ROBIN** engine Owner's Manual for engine storage.
- Completely drain the compactor's oil from the vibrating case.
- Clean entire plate compactor, especially the bottom plate, removing all dirt and foreign matter.
- Cover plate compactor and engine with plastic covering or equivalent and store in a clean, dry place.

# MVC-70E/EW — TROUBLESHOOTING (ENGINE)

**TABLE 8. ENGINE TROUBLESHOOTING**

SYMPTOM	POSSIBLE CAUSE	SOLUTION
Difficult to start, "fuel is available, but no SPARK at spark plug".	Spark plug bridging?	Check gap, insulation or replace spark plug.
	Carbon deposit on spark plug?	Clean or replace spark plug.
	Short circuit due to deficient spark plug insulation?	Check spark plug insulation, replace if worn.
	Improper spark plug gap?	Set to proper gap.
Difficult to start, "fuel is available, and SPARK is present at the spark plug".	ON/OFF switch is shorted?	Check switch wiring, replace switch.
	Ignition coil defective?	Replace ignition coil.
	Improper spark gap, points dirty?	Set correct spark gap and clean points.
	Condenser insulation worn or short circuiting?	Replace condenser.
	Spark plug wire broken or short circuiting?	Replace defective spark plug wiring.
Difficult to start, "fuel is available, spark is present and compression is normal"	Wrong fuel type?	Flush fuel system, and replace with correct type of fuel.
	Water or dust in fuel system?	Flush fuel system.
	Air cleaner dirty?	Clean or replace air cleaner.
Difficult to start, "fuel is available, spark is present and compression is low"	Suction/exhaust valve stuck or protruded?	Re-seat valves.
	Piston ring and/or cylinder worn?	Replace piston rings and or piston.
	Cylinder head and/or spark plug not tightened properly?	Torque cylinder head bolts and spark plug.
	Head gasket and/or spark plug gasket damaged?	Replace head and spark plug gaskets.
No fuel present at carburetor.	Fuel not available in fuel tank?	Fill with correct type of fuel.
	Fuel cock does not open properly?	Apply lubricant to loosen fuel cock lever, replace if necessary.
	Fuel filter clogged?	Replace fuel filter.
	Fuel tank cap breather hole clogged?	Clean or replace fuel tank cap.
	Air in fuel line?	Bleed fuel line.



# MVC-70E/EW — TROUBLESHOOTING (ENGINE)

**TABLE 8. ENGINE TROUBLESHOOTING (CONTINUED)**

SYMPTOM	POSSIBLE CAUSE	SOLUTION
"Weak in power" compression is proper and does not misfire.	Air cleaner not clean?	Clean or replace air cleaner
	Improper level in carburetor?	Check float adjustment, re-build carburetor.
	Defective Spark plug?	Clean or replace spark plug.
	Defective Spark plug?	
"Weak in power" compression is proper but misfires.	Water in fuel system?	Flush fuel system, and replace with correct type of fuel.
	Dirty spark plug?	Clean or replace spark plug.
	Ignition coil defective?	Replace ignition coil.
Engine overheats.	Spark plug heat value improper?	Replace with correct type of spark plug.
	Correct type of fuel?	Replace with correct type of fuel
	Cooling fins dirty?	Clean cooling fins.
Rotational speed fluctuates.	Governor adjusted correctly?	Adjust governor.
	Governor spring defective?	Replace governor spring.
	Fuel flow restricted?	Check entire fuel system for leaks or clogs.
Recoil starter malfunction.	Recoil mechanism clogged with dust and dirt?	Clean recoil assembly with soap and water.
	Spiral spring loose?	Replace spiral spring.

# MVC-70E/EW — TROUBLESHOOTING (PLATE COMPACTOR)

**TABLE 9. PLATE COMPACTOR TROUBLESHOOTING**

SYMPTOM	POSSIBLE CAUSE	SOLUTION
Travel speed too low, and vibration is weak.	Engine speed too low?	Set engine speed to correct RPM.
	Clutch slips?	Check or replace clutch.
	V-belt slips?	Adjust or replace V-belt.
	Excessive oil in vibrator?	Drain excess oil and fill to proper level.
	Malfunction in vibrator housing?	Check eccentric, gears and counter weights.
Does not travel forward.	V-belt slips?	Replace V-belt.
	Clutch slips?	Check clutch springs and shoes.
	Vibrator locked?	Check vibrator housing (eccentric, gears and counterweights)



# MVC-70E/EW— EXPLANATION OF CODES IN REMARKS COLUMN

The following section explains the different symbols and remarks used in the Parts section of this manual. Use the help numbers found on the back page of the manual if there are any questions.

The contents and part numbers listed in the parts section are subject to change **without notice**. Multiquip does not guarantee the availability of the parts listed.

Sample Parts List:

NO.	PART NO.	PART NAME	QTY.	REMARKS
1	12345	BOLT .....	1 ....	INCLUDES ITEMS W/*
2*		WASHER, 1/4 IN. ....		NOT SOLD SEPARATELY
2*	12347	WASHER, 3/8 IN. ....	1 ....	MQ-45T ONLY
3	12348	HOSE .....	A/R ..	MAKE LOCALLY
4	12349	BEARING .....	1 ....	S/N 2345B AND ABOVE

## NO. Column

**Unique Symbols** - All items with same unique symbol (\*, #, +, %, or >) in the number column belong to the same assembly or kit, which is indicated by a note in the "Remarks" column.

**Duplicate Item Numbers** - Duplicate numbers indicate multiple part numbers are in effect for the same general item, such as different size saw blade guards in use or a part that has been updated on newer versions of the same machine.

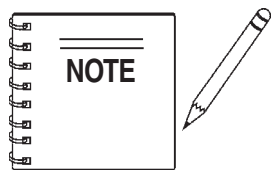

When ordering a part that has more than one item number listed, check the remarks column for help in determining the proper part to order.

## PART NO. Column

**Numbers Used** - Part numbers can be indicated by a number, a blank entry, or TBD.

TBD (To Be Determined) is generally used to show a part that has not been assigned a formal part number at time of publication.

A blank entry generally indicates that the item is not sold separately or is not sold by Multiquip. Other entries will be clarified in the "Remarks" Column.

## QTY. Column

**Numbers Used** - Item quantity can be indicated by a number, a blank entry, or A/R.

A/R (As Required) is generally used for hoses or other parts that are sold in bulk and cut to length.

A blank entry generally indicates that the item is not sold separately. Other entries will be clarified in the "Remarks" Column.

## REMARKS Column

Some of the most common notes found in the "Remarks" Column are listed below. Other additional notes needed to describe the item can also be shown.

**Assembly/Kit** - All items on the parts list with the same unique symbol will be included when this item is purchased.

Indicated by:  
"INCLUDES ITEMS W/(unique symbol)"

**Serial Number Break** - Used to list an effective serial number range where a particular part is used.

Indicated by:  
"S/N XXXXX AND BELOW"  
"S/N XXXX AND ABOVE"  
"S/N XXXX TO S/N XXX"

**Specific Model Number Use** - Indicates that the part is used only with the specific model number or model number variant listed. It can also be used to show a part is NOT used on a specific model or model number variant.

Indicated by:  
"XXXXX ONLY"  
"NOT USED ON XXXX"

**"Make/Obtain Locally"** - Indicates that the part can be purchased at any hardware shop or made out of available items. Examples include battery cables, shims, and certain washers and nuts.

**"Not Sold Separately"** - Indicates that an item cannot be purchased as a separate item and is either part of an assembly/kit that can be purchased, or is not available for sale through Multiquip.

## MVC-70E/EW— SUGGESTED SPARE PARTS

### MVC-70E/EW 1 TO 3 UNITS WITH ROBIN EX170D40050 GASOLINE ENGINE

Qty.	P/N	Description
3 .....	2773261107 .....	ELEMENT, AIR
3 .....	0650140150 .....	SPARK PLUG
1 .....	0430440050 .....	FUEL TANK CAP
1 .....	2825011118 .....	STARTER ROPE
1 .....	0641360010 .....	FUEL FILTER
3 .....	070100312 .....	V-BELT
4 .....	939010254 .....	SHOCK ABSORBER

# MVC-70E/EW— NAME PLATE AND DECALS

## NAME PLATE AND DECALS

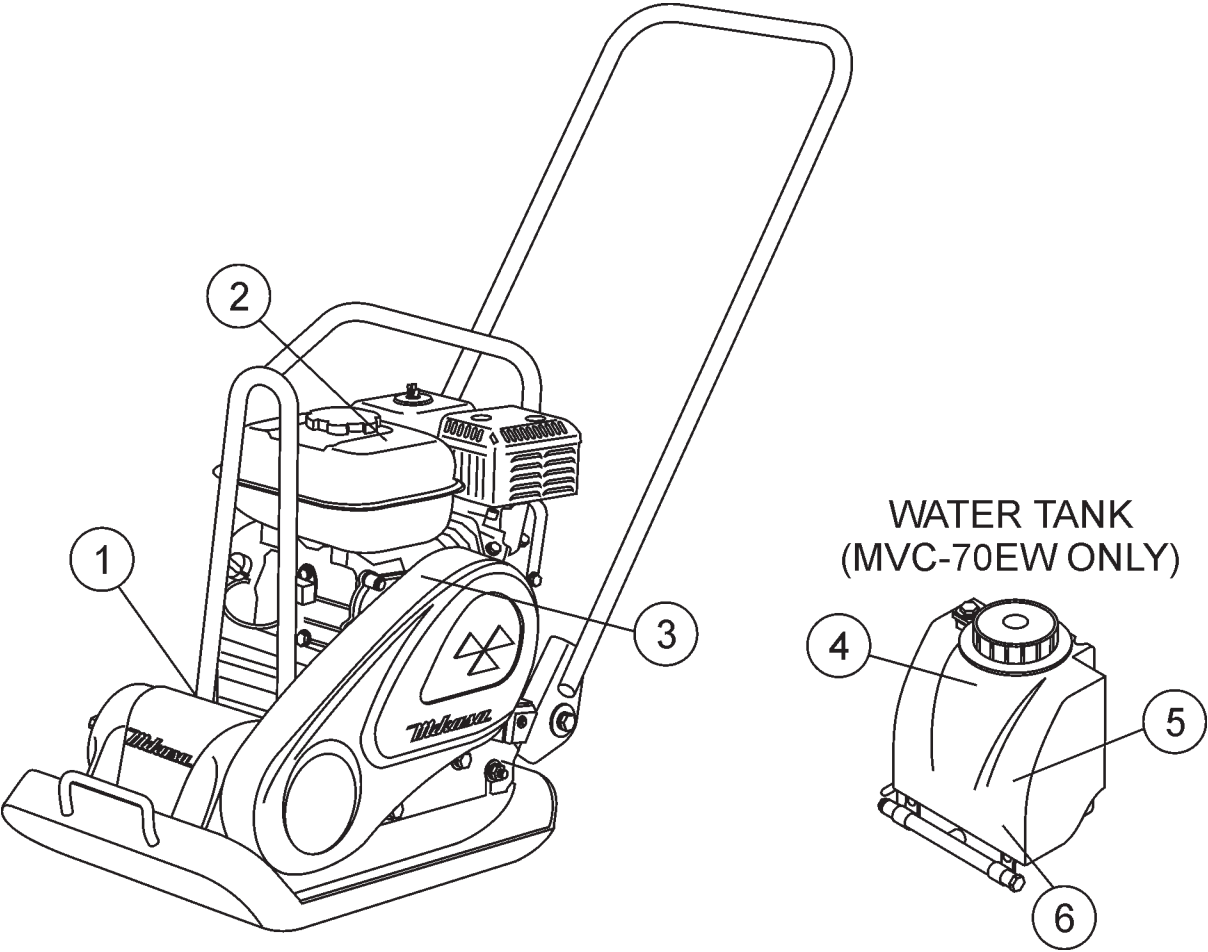

## MVC-70E/EW— NAME PLATE AND DECALS

### NAMEPLATE AND DECALS

<u>NO.</u>	<u>PART NO.</u>	<u>PART NAME</u>	<u>QTY.</u>	<u>REMARKS</u>
1		PLATE, MODEL/SERIAL NUMBER .....	1 .....	CONTACT PARTS DEPT.
2	920203290	DECAL, READ OWNERS MANUAL .....	1 .....	NPA-329
3	920203989	DECAL, BELT GUARD WARNING .....	1 .....	NPA-989
4	920101410	DECAL: MIKASA MARK 120X60 .....	1 .....	WATER TANK
5	920201580	DECAL: MQ MARK 71X55 .....	1 .....	MQ/WATER TANK
6	920105070	DECAL: MIKASA MARK 125MM .....	1 .....	WATER TANK

# MVC-70E/EW — MAIN BODY ASSY.

MAIN BODY ASSY.

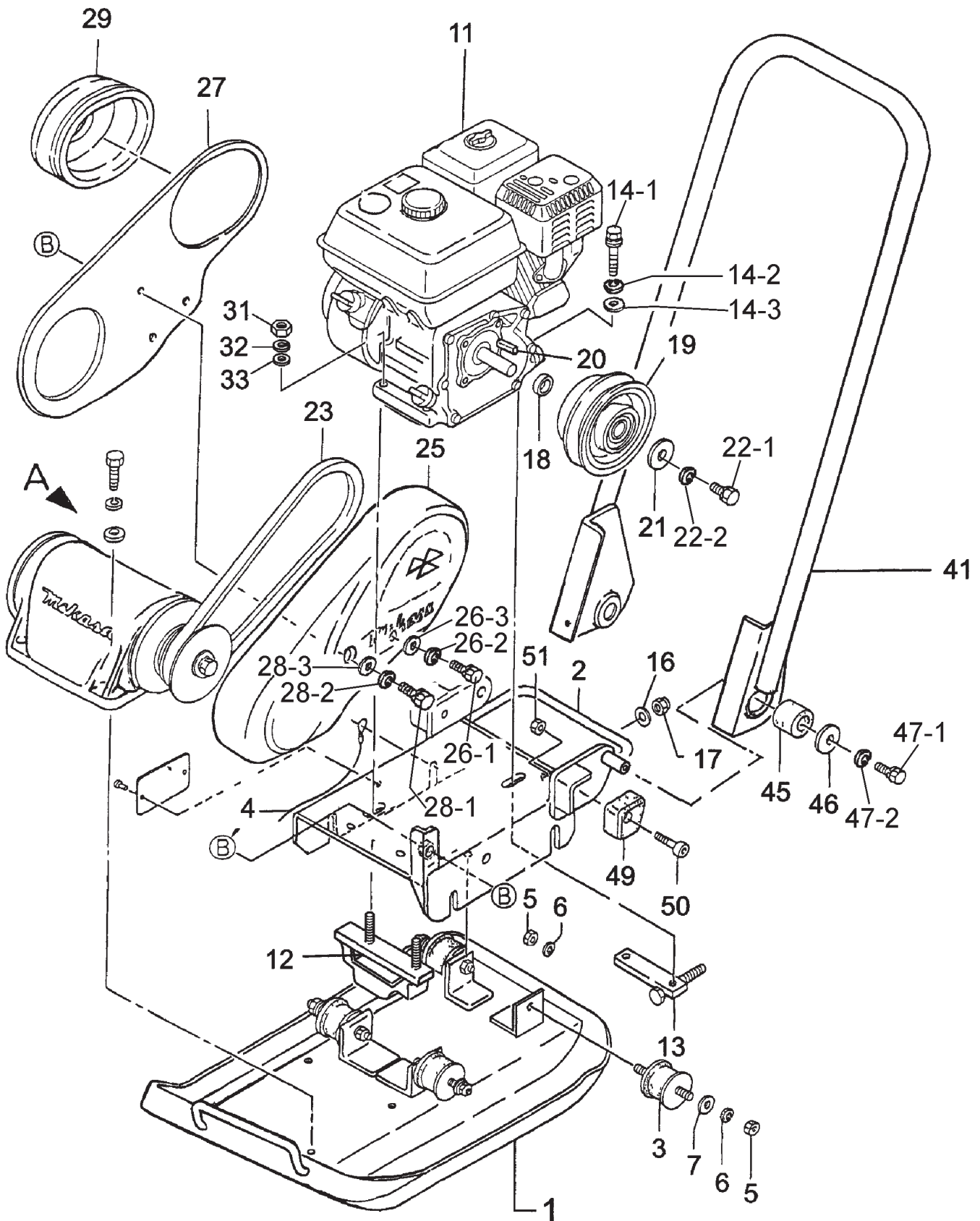



# MVC-70E/EW — MAIN BODY ASSY.

## MAIN BODY ASSY.

<u>NO</u>	<u>PART NO</u>	<u>PART NAME</u>	<u>QTY.</u>	<u>REMARKS</u>
1	418117721	VIBRATORY PLATE	1	
2	418216501	BASE	1	
3	939010254	SHOCK ABSORBER D45-H41	4	
4	959404350	EARTH WIRE	1	
5	020310080	NUT M10	8	
6	030210250	WASHER, LOCK M10	8	
7	031110160	WASHER, FLAT M10	4	
11	911221703	ENGINE, ROBIN EX170D40050	1	
12	418457750	BOLT, ENGINE	1	
13	413436870	ENGINE NUT, REAR	1	
14-1	002410840	BOLT 8X40 H, SW, PW	2	
14-2	030208200	WASHER, LOCK M8	2	
14-3	031108160	WASHER, FLAT M8	2	
16	031108160	WASHER, FLAT M8	1	
17	022710809	NYLON NUT M8	1	
18	408421270	SPACER 20.2X25X9.4, CLUTCH	1	
19	413332920	CLUTCH ASSY.	1	
20	0053005201	KEY	1	
21	952400130	WASHER 9304	1	
22-1	001220820	BOLT 8X20 H, SW	1	
22-2	030208200	WASHER, LOCK	1	
23	070100312	V-BELT RPF-3310	1	
25	418216470	BELT COVER	1	
26-2	030210250	WASHER, LOCK	1	
26-3	031110160	WASHER, FLAT	1	
27	418216480	BELT COVER, IN.	1	
28-1	001221053	BOLT 10X65 SW, PW	1	
28-2	030210250	WASHER, LOCK	1	
28-3	031110160	WASHER, FLAT	1	
29	418343420	COVER SEAL, E/G	1	
31	020308060	NUT M8	2	
32	030208200	WASHER, LOCK	2	
33	031108160	WASHER, FLAT	2	
41	413216250	HANDLE LONG	1	
45	404433430	RUBBER 20X32X28.5/52H	2	
46	952403450	WASHER 11X35X4.5	2	
47-1	001221020	BOLT 10X20 H,SW	2	
47-2	030210250	WASHER, LOCK M10	2	
49	413436720	RUBBER, HANDLE	2	
50	001520845	SOCKET HEAD BOLT 8X45 T	2	
51	020308060	NUT M8	2	

# MVC-70E/EW—VIBRATOR ASSY.

VIBRATOR ASSY.

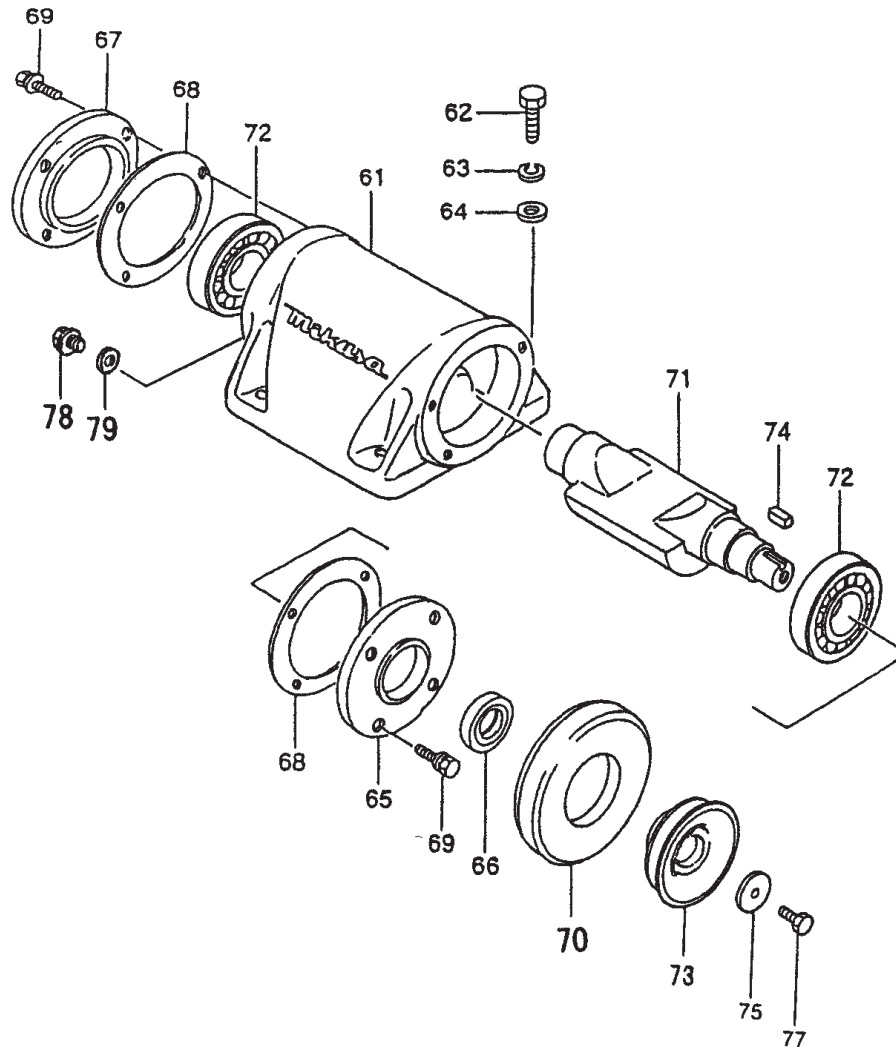

## MVC-70E/EW—VIBRATOR ASSY.

### VIBRATOR ASSY.

<b><u>NO</u></b>	<b><u>PART NO</u></b>	<b><u>PART NAME</u></b>	<b><u>QTY.</u></b>	<b><u>REMARKS</u></b>
61	418117730	VIBRATING CASE	1	
62	001221445	BOLT 14X45 T	4	
63	030214350	WASHER, LOCK M14	4	
64	031114260	WASHER, FLAT M14	4	
65	418456950	CASE COVER/PULLEY	1	
66	060403020	OIL SEAL TC-30458	1	
67	418456960	CASE COVER/SHUT-OFF	1	
68	418456970	PACKING	2	
69	002400820	BOLT 8X20 SW, PW	8	
70	418456990	COVER SEAL, VIB.	1	
71	418343400	ECC. ROTOR SHAFT	1	
72	040306307	BEARING 6307C3	2	
72	040406307	BEARING 6307C4	2	
73	418456980	PULLEY, VIB.	1	
74	951401920	KEY 7X7X30	1	
75	952403450	WASHER 11X35X4.5	1	
77	002211030	BOLT 10X30 H, SW	1	
78	953400270	PLUG 1/4X14 10L	1	
79	953405260	PACKING	1	

# MVC-70E/EW—WATERTANK ASSY.

WATER TANK ASSY.

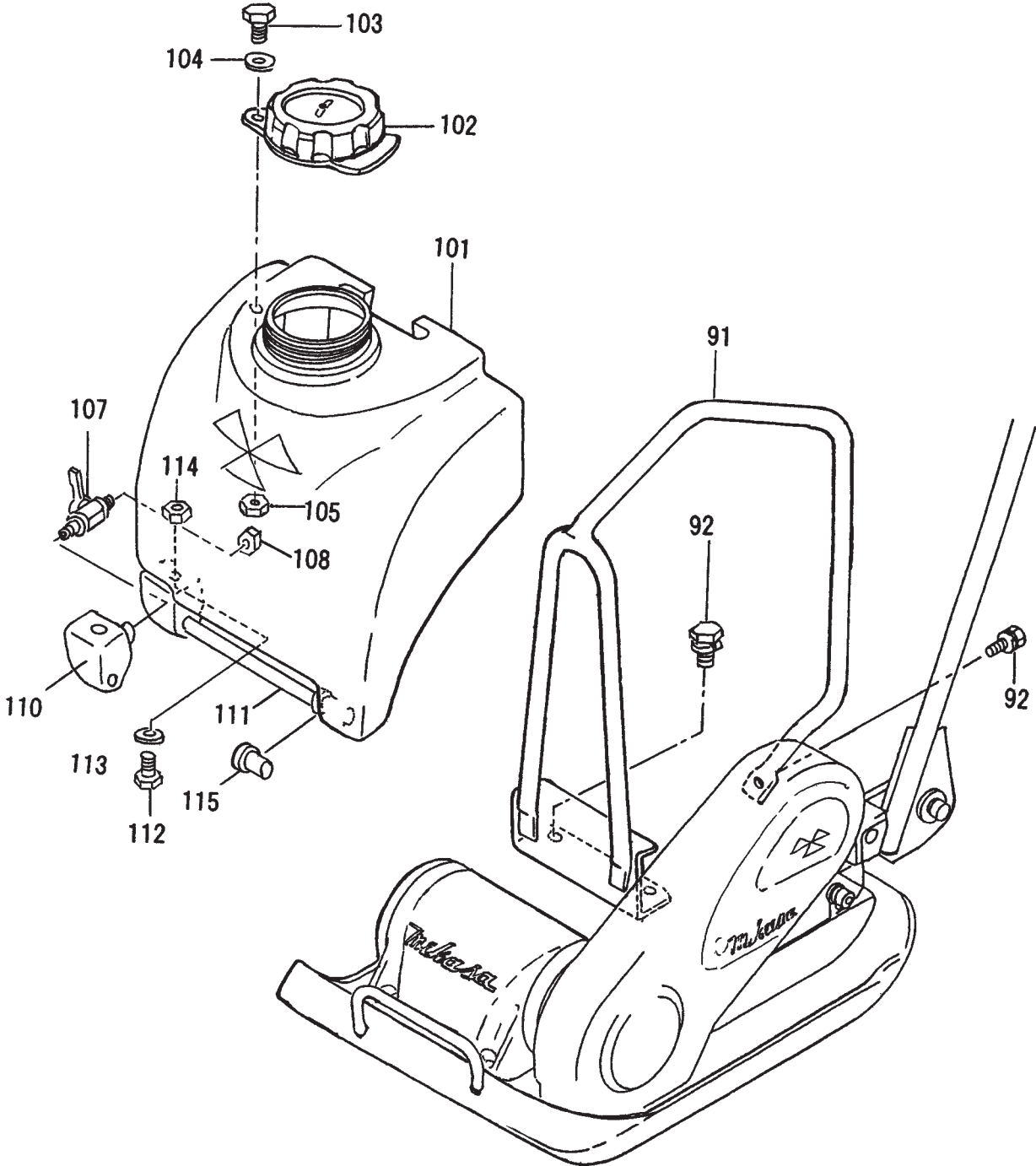

# MVC-70E/EW—WATER TANK ASSY.

## WATER TANK ASSY.

<u>NO</u>	<u>PART NO</u>	<u>PART NAME</u>	<u>QTY.</u>	<u>REMARKS</u>
91	418216510	HOOK	1	
92	002211025	BOLT 10X25 H, SW	3	
101	418910010	WATER TANK, GREEN .....	1 .....	INCLUDES ITEM W/*
101	418910020	WATER TANK, ORANGE .....	1 .....	INCLUDES ITEM W/*
102*	954300342	CAP, WATER TANK	1	
103*	001241030	BOLT 10X30 U	1	
104*	033910010	WASHER 10.5X21X2 SUS.	2	
105*	022910180	NYLON NUT M10 SUS.	1	
107	954403241	COCK PT1/4, BH-1211 AL.	1	
108	959403790	NUT PS-1/4	1	
110	416338940	PIPE HOLDER, L	1	
111	418343430	SPRINKLING PIPE	1	
112	001220825	BOLT 8X25 T	1	
113	031108160	WASHER, LOCK M8	2	
114	020308060	NUT M8	1	
115	418457010	RUBBER CAP	1	

# EX-170D40050 — AIR CLEANER ASSY.

AIR CLEANER ASSY.

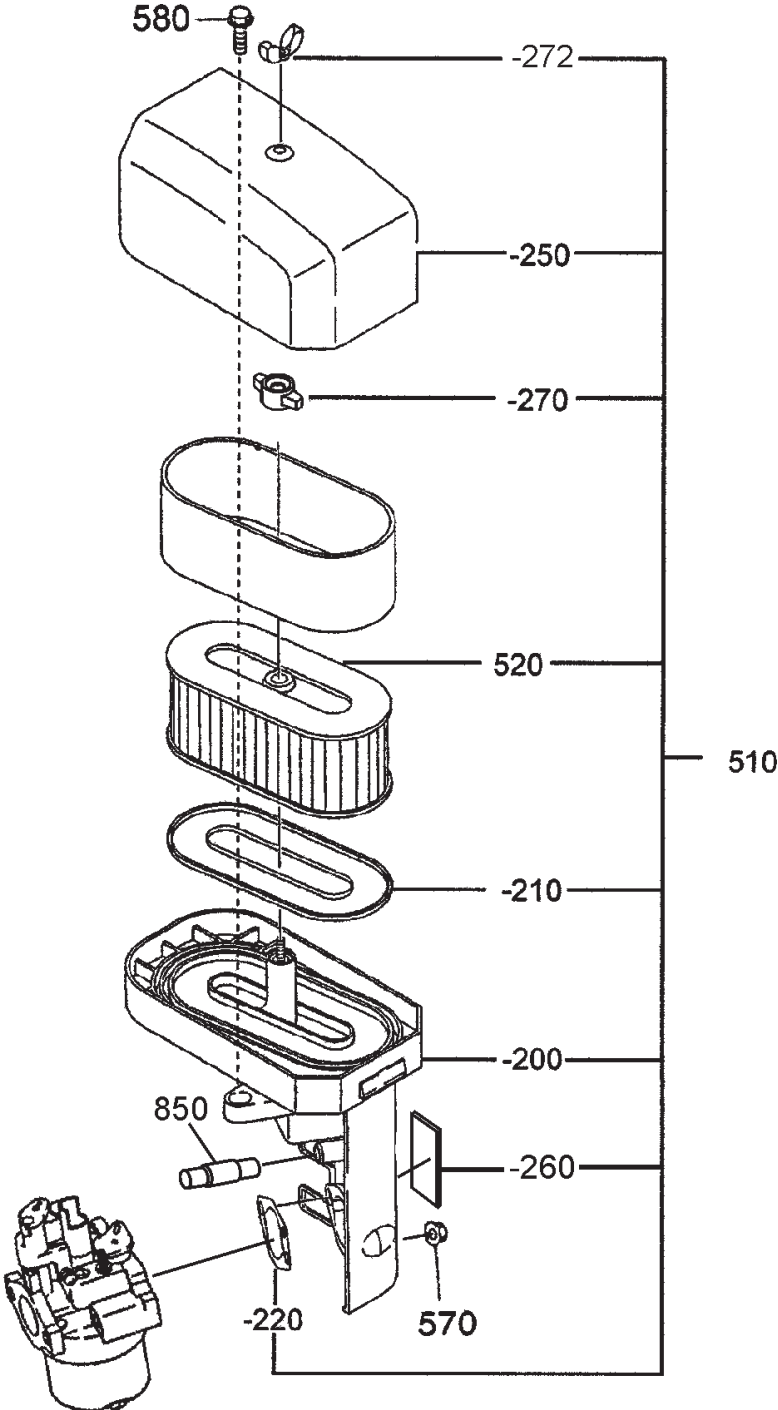

CARBURETOR  
REFERENCE  
ONLY

# EX-170D40050 — AIR CLEANER ASSY.

## AIR CLEANER ASSY.

<u>NO</u>	<u>PART NO</u>	<u>PART NAME</u>	<u>QTY.</u>	<u>REMARKS</u>
510	2773261500	AIR CLEANER ASSY. ....	1	INCLUDES ITEMS W/ *
200*	2773263008	BASE, CLEANER	1	
210*	2773261008	PACKING, CLEANER	1	
220*	2773260408	GASKET, CLEANER	1	
250*	2773264008	COVER, CLEANER	1	
260*	2773260908	LABEL, THROTTLE	1	
270*	2773274108	WING, NUT	1	
272*	2773274008	WING, NUT	1	
520*	2773261107	CLEANER, ELEMENT	1	
570	0023806000	FLANGE NUT	2	
580	0110060050	FLANGE BOLT	1	
850	0851080000	RUBBER PIPE	1	

CAMSHAFT ASSY.

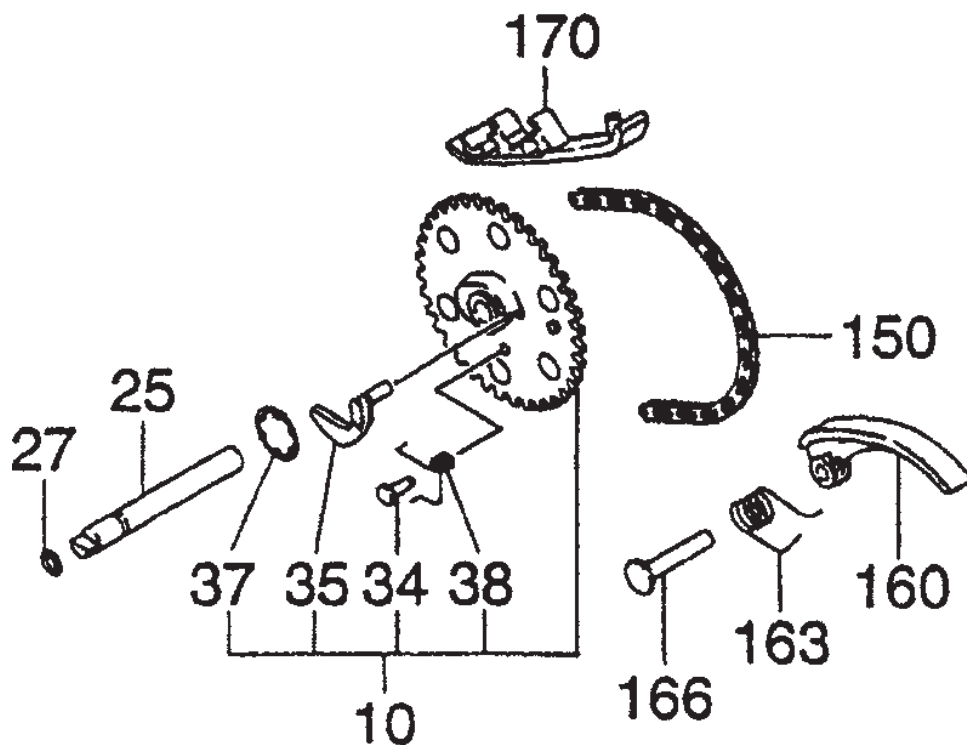



# EX-170D40050 — CAMSHAFT ASSY.

## CAMSHAFT ASSY.

<u>NO</u>	<u>PART NO</u>	<u>PART NAME</u>	<u>QTY.</u>	<u>REMARKS</u>
10	2773160101	CAMSHAFT .....	1 .....	INCLUDES ITEMS W/%
25	2773510103	PIN, CAMSHAFT	1	
27	0240060010	O-RING	1	
34%	2773860103	PIN, SPRING	1	
35%	2773640103	RELEASE LEVER	1	
37%	2773650103	CLIP	1	
38%	2773870103	RETURN SPRING	1	
150	2773560101	CHAIN, TIMING	1	
160	2773691103	TENSIONER	1	
163	2773710103	SPRING, TENSIONER	1	
166	2773690203	PIN, TENSIONER	1	
170	2773691313	CHAIN, GUIDE	1	

# EX-170D40050 — CARBURETOR ASSY.

CARBURETOR ASSY.

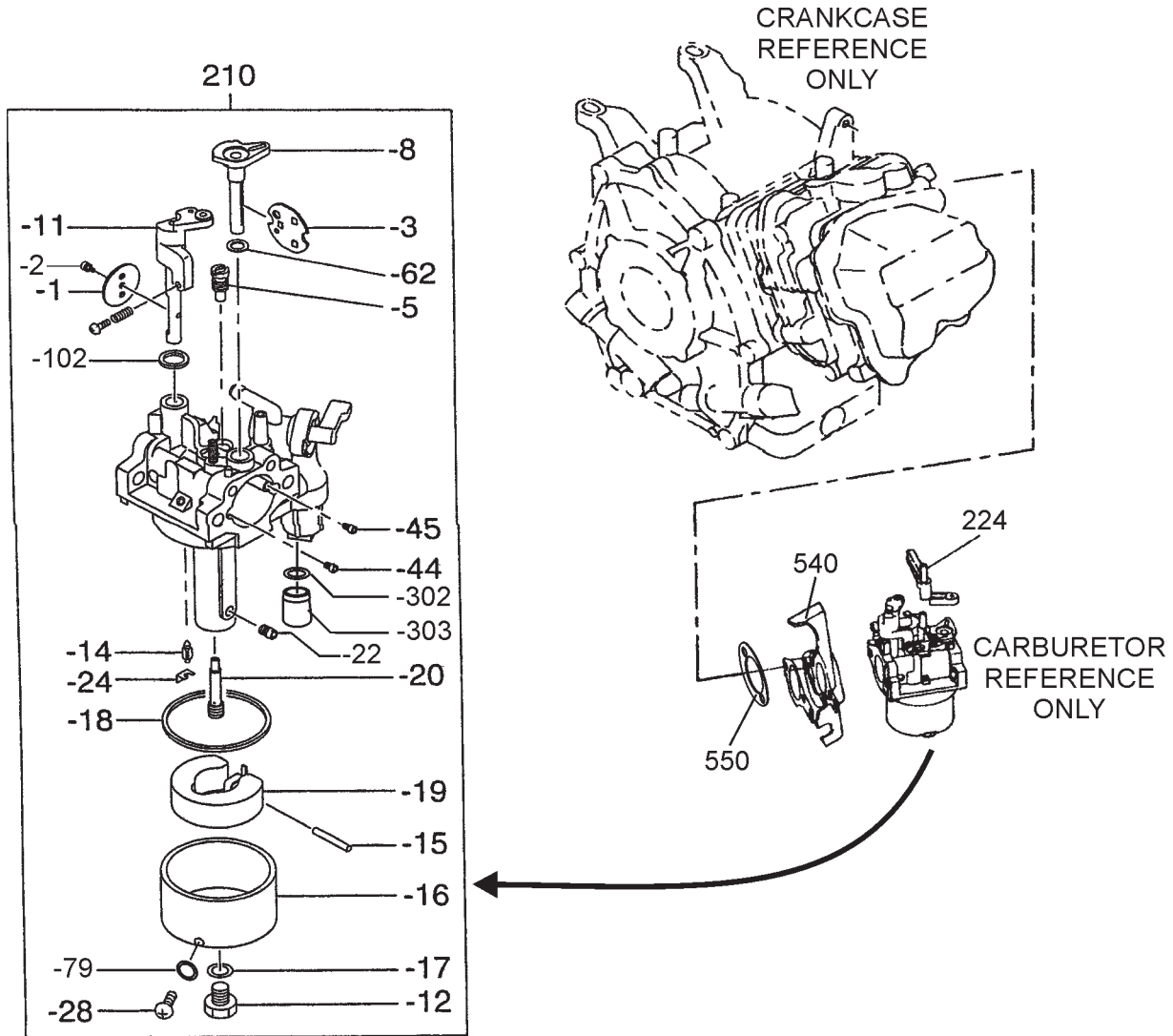

# EX-170D40050 — CARBURETOR ASSY.

## CARBURETOR ASSY.

<u>NO</u>	<u>PART NO</u>	<u>PART NAME</u>	<u>QTY.</u>	<u>REMARKS</u>
210	2776230210	CARBURETOR ASSY. ....	1.....	INCLUDES ITEMS W/ *
210-1*	2776253508	THROTTLE VALVE	1	
210-2*	2096235108	SCREW	1	
210-3*	2776252508	CHOKE VALVE	1	
210-5*	2466242008	PILOT JET	1	
210-8*	2776252008	CHOKE LEVER	1	
210-11*	2776253108	THROTTLE SHAFT	1	
210-12*	2276245108	BOLT	1	
210-14*	2776250008	NEEDLE	1	
210-15*	2776251508	FLOAT PIN	1	
210-16*	2776250608	FLOAT BODY	1	
210-17*	2146245008	PACKING	1	
210-18*	2146254008	FLOAT CHAMBER PACKING	1	
210-19*	2266250608	FLOAT ASSY.	1	
210-20*	2776244008	MAIN NOZZLE	1	
210-22*	2266241208	MAIN JET	1	
210-24*	2266270118	CLIP	1	
210-28*	2776236008	BOLT	1	
210-44*	2486241008	AIR JET	1	
210-45*	1066241008	AIR JET (PILOT)	1	
210-62*	2366268008	SEAL	1	
210-79*	2366254108	PACKING	1	
210-102*	2466239008	SEAL	1	
210-302*	0642006410	RUBBER PACKING	1	
210-303*	0642007810	CUP	1	
224	2774380101	CHOKE LEVER	1	
540	2773290113	INSULATOR	1	
550	2773590113	GASKET, INSULATOR	1	

# EX-170D40050 — CRANKCASE ASSY.

CRANKCASE ASSY.

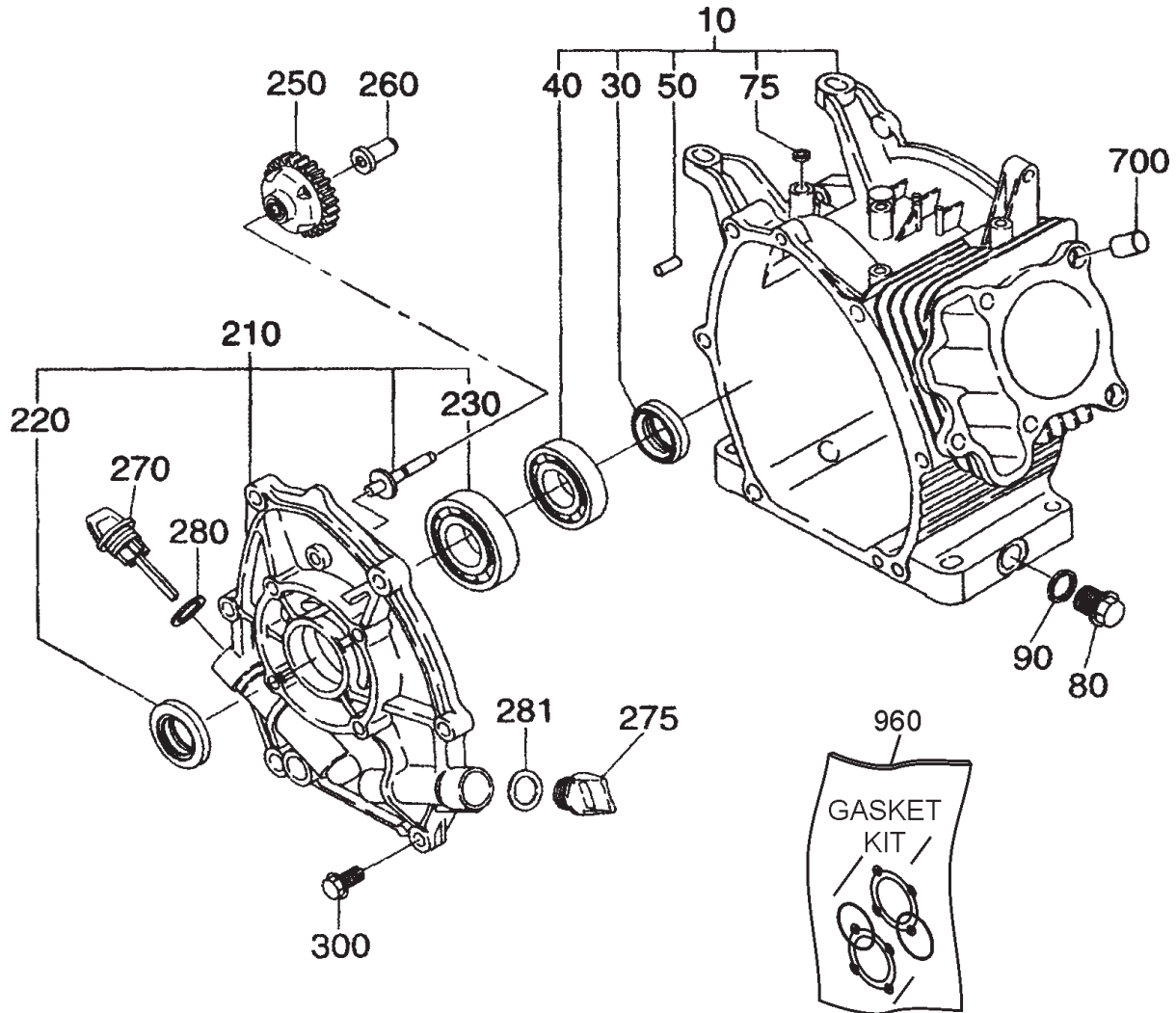

## EX-170D40050 — CRANKCASE ASSY.

### CRANKCASE ASSY.

<b>NO</b>	<b>PART NO</b>	<b>PART NAME</b>	<b>QTY.</b>	<b>REMARKS</b>
10	2771010141	CRANKCASE CP, W/OIL SENSOR .....	1 .....	INCLUDES ITEMS W/*
30*	0440250200	OIL SEAL	1	
40*	0600280021	BALL BEARING	1	
50*	2771501103	PIPE KNOCK	2	
75*	0440060020	OIL SEAL	1	
80	0401140030	PLUG	2	
90\$	0211140020	GASKET	2	
210	2771100131	MAIN BEARING COVER CP .....	1 .....	INCLUDES ITEMS W/%
220%	0440250210	OIL SEAL	1	
230%	0600250140	BALL BEARING	1	
250	2774500421	GOVERNOR GEAR	1	
260	2634190103	GOVERNOR SLEEVE	1	
270	2776360113	OIL GAUGE	1	
275	2776500103	FILLER, PLUG	1	
280\$	0213160020	GASKET	1	
281	0213160020	GASKET	1	
300	0010408350	FLANGE BOLT	6	
700	2771501103	PIPE KNOCK	2	
960	2779900107	GASKET SET	1	INCLUDES ITEMS W/ \$, ITEMS 620 AND 690 IN CYLINDER HEAD ASSY, AND ITEM 340 IN MUFFLER ASSY

# EX-170D40050 — CRANKSHAFT/PISTON ASSY.

CRANKSHAFT/PISTON ASSY.

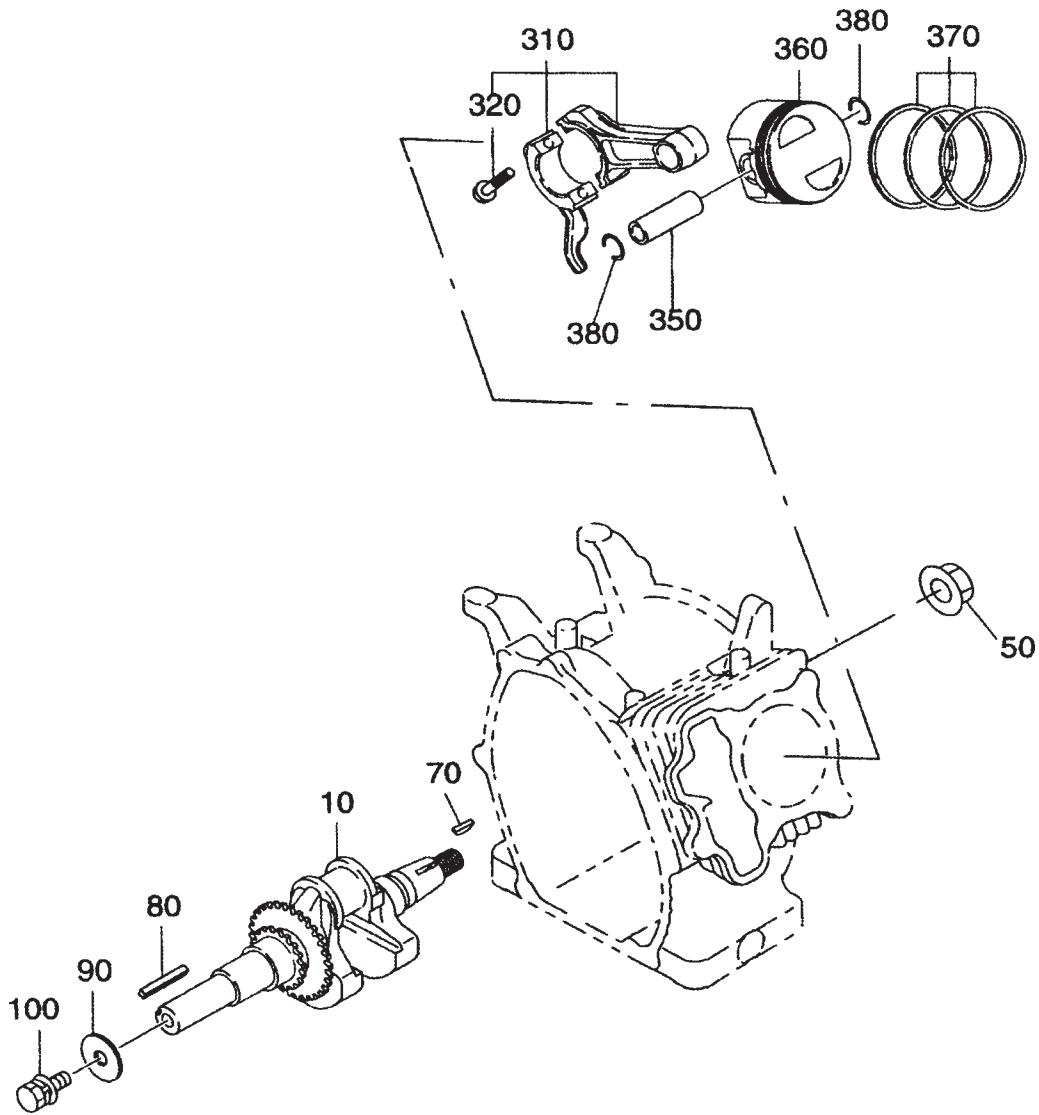

## EX-170D40050 — CRANKSHAFT/PISTON ASSY.

### CRANKSHAFT/PISTON ASSY.

<u>NO</u>	<u>PART NO</u>	<u>PART NAME</u>	<u>QTY.</u>	<u>REMARKS</u>
10	2772020111	CRANKSHAFT	1	
50	0180140020	FLANGE NUT	1	
70	0323030010	WOODRUFF KEY	1	
80	0053005301	KEY	1	
90	0200080050	WASHER	1	
100	0011308200	BOLT & WASHER ASSY.	1	
310	2772250110	CONNECTING ROD ASSY. ....	1	INCLUDES ITEMS W/*
320*	2772300103	CONNECTING ROD BOLT	2	
350	2772330103	PISTON PIN	1	
360	2772340103	PISTON STD.	1	
360	2772340303	PISTON, 0.25 O.S.	1	
360	2772340403	PISTON, 050 O.S.	1	
370	2772351127	PISTON RING SET STD.	1	
370	2772351207	PISTON RING SET, 0.25 O.S.	1	
370	2772351307	PISTON RING SET, 0.5 O.S.	1	
380	0565160010	CLIP	2	

# EX-170D40050 — CYLINDER HEAD ASSY.

CYLINDER ASSY.

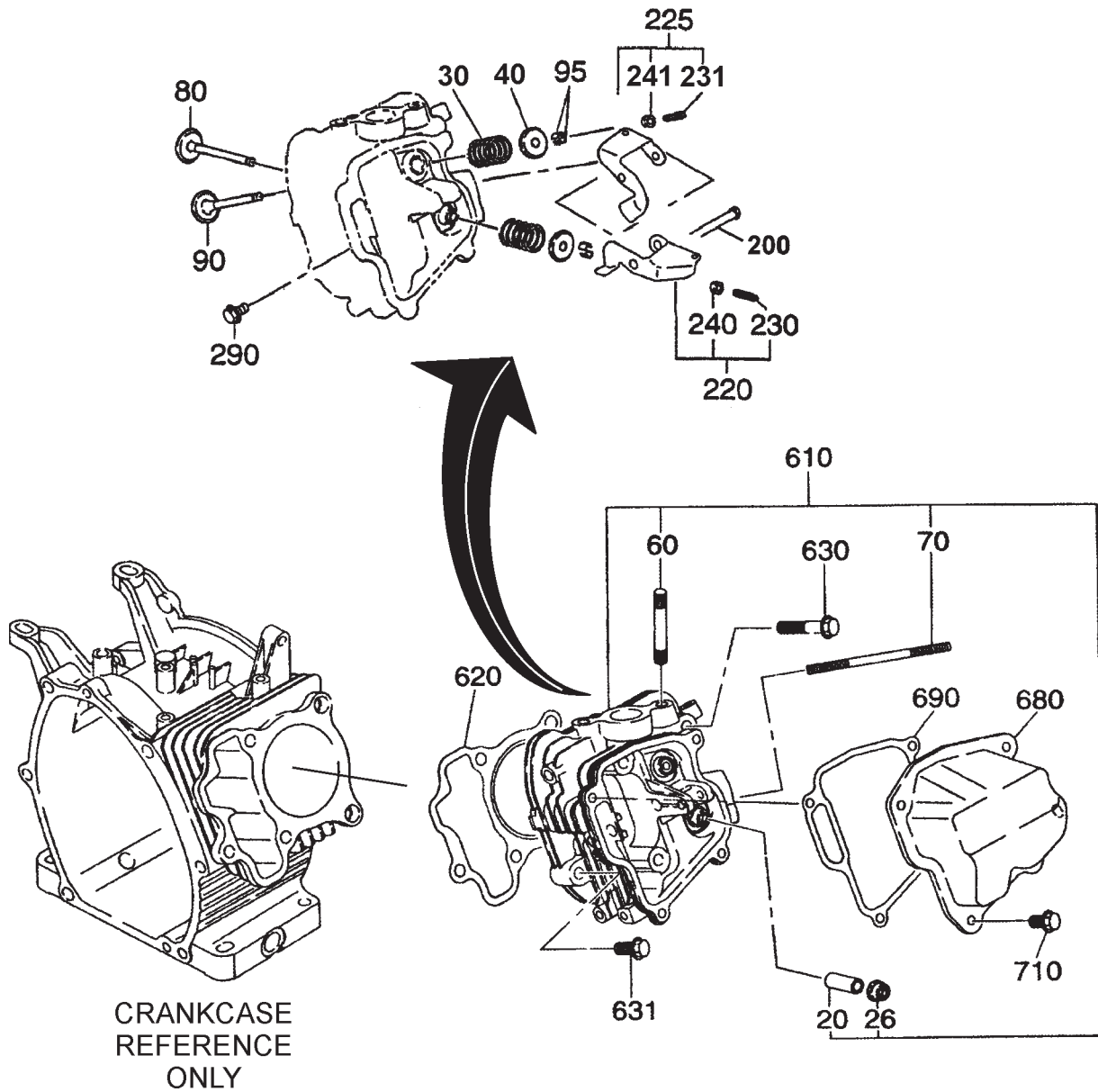



# EX-170D40050 — CYLINDER HEAD ASSY.

## CYLINDER ASSY.

<u>NO</u>	<u>PART NO</u>	<u>PART NAME</u>	<u>QTY.</u>	<u>REMARKS</u>
20#	2371420203	VALVE GUIDE	2	
26#	2771601001	STEM SEAL	1	
30	2793360103	VALVE, SPRING	2	
40	2693370103	SPRING RETAINER	2	
60#	0105080250	STUD	2	
70#	0105060351	STUD	2	
80	2773340113	INTAKE VALVE	1	
90	2773350113	EXHAUST VALVE	1	
95	13210KA031	COLLET VALVE	4	
200	2773500123	PIN, ROCKER	1	
220	2773610100	ROCKER, ARM ASSY. IN .....	1	INCLUDES ITEMS W/ +
225	2773610200	ROCKER, ARM EX .....	1	INCLUDES ITEMS W/ \$
230+	0149050010	ADJUSTING SCREW	1	
231\$	0149050010	ADJUSTING SCREW	1	
240+	0170050020	NUT	1	
241\$	0170050020	NUT	1	
290	0110060020	FLANGE BOLT	1	
610	2771300101	CYLINDER HEAD .....	1	INCLUDES ITEMS W/#
620	2771500113	GASKET HEAD	1	
630	0110080240	FLANGE BOLT	4	
631	0010408350	FLANGE BOLT	1	
680	2771550101	ROCKER, COVER	1	
690	2771600103	GASKET, LOCKER COVER	1	
710	0110060020	FLANGE BOLT	4	

# EX-170D40050 — FUEL TANK ASSY.

FUEL TANK ASSY.

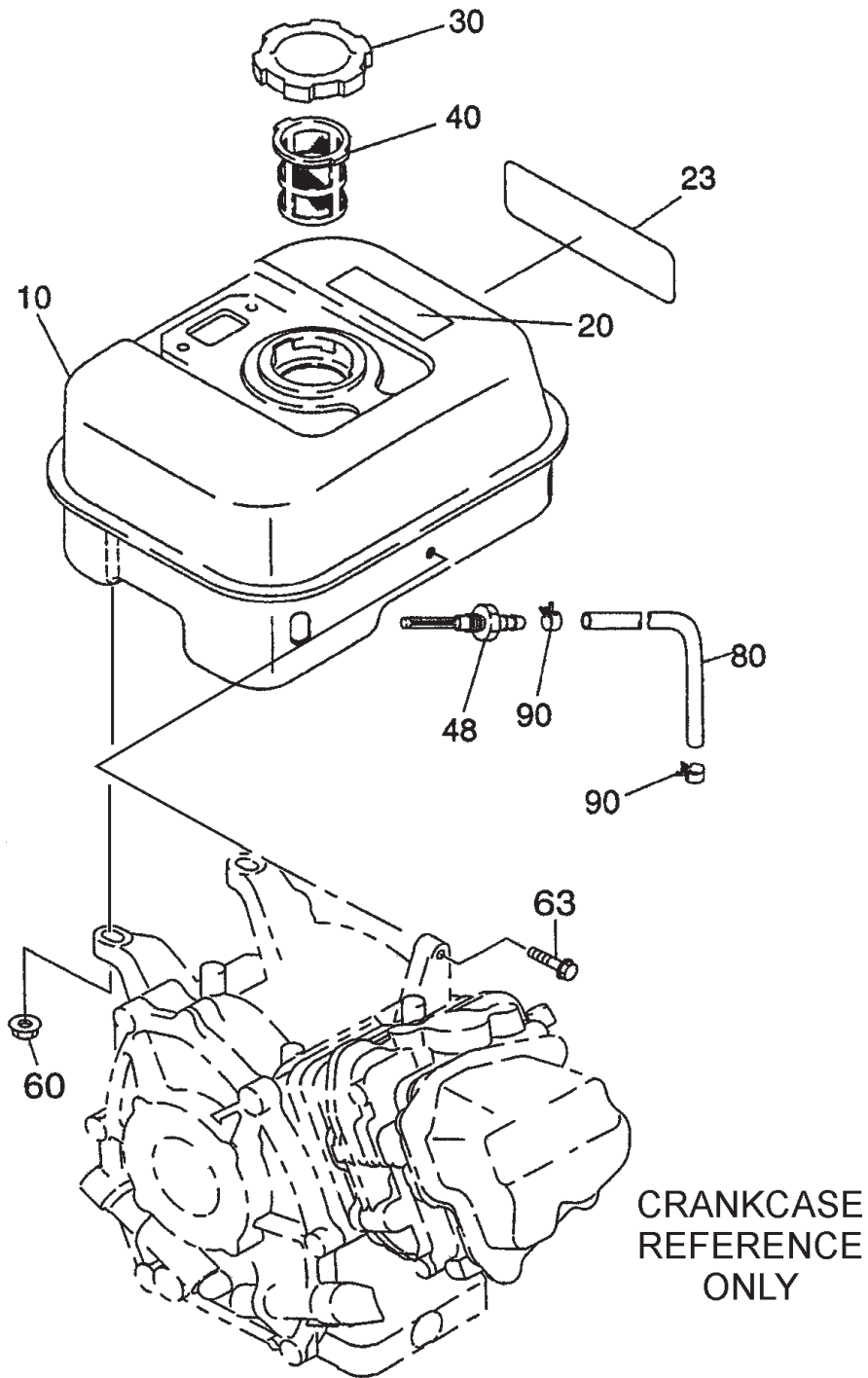

## FUEL TANK ASSY.

<b><u>NO</u></b>	<b><u>PART NO</u></b>	<b><u>PART NAME</u></b>	<b><u>QTY.</u></b>	<b><u>REMARKS</u></b>
10	2776010201	FUEL TANK	1	
20	0732005180	LABEL, WARNING	1	
23	2779510103	LABEL, MODEL	1	
30	0430440050	FUEL TANK, CAP	1	
40	0641360010	FUEL FILTER	1	
48	0505120020	UNION	1	
60	0023806000	FLANGE, NUT	2	
63	0110060130	FLANGE, BOLT	1	
80	0851960000	RUBBER PIPE, 6DX11D	1	
90	0561100030	HOSE CLAMP, 10DX8BX1T	2	

# EX-170D40050 — GOVERNOR ASSY.

GOVERNOR ASSY.

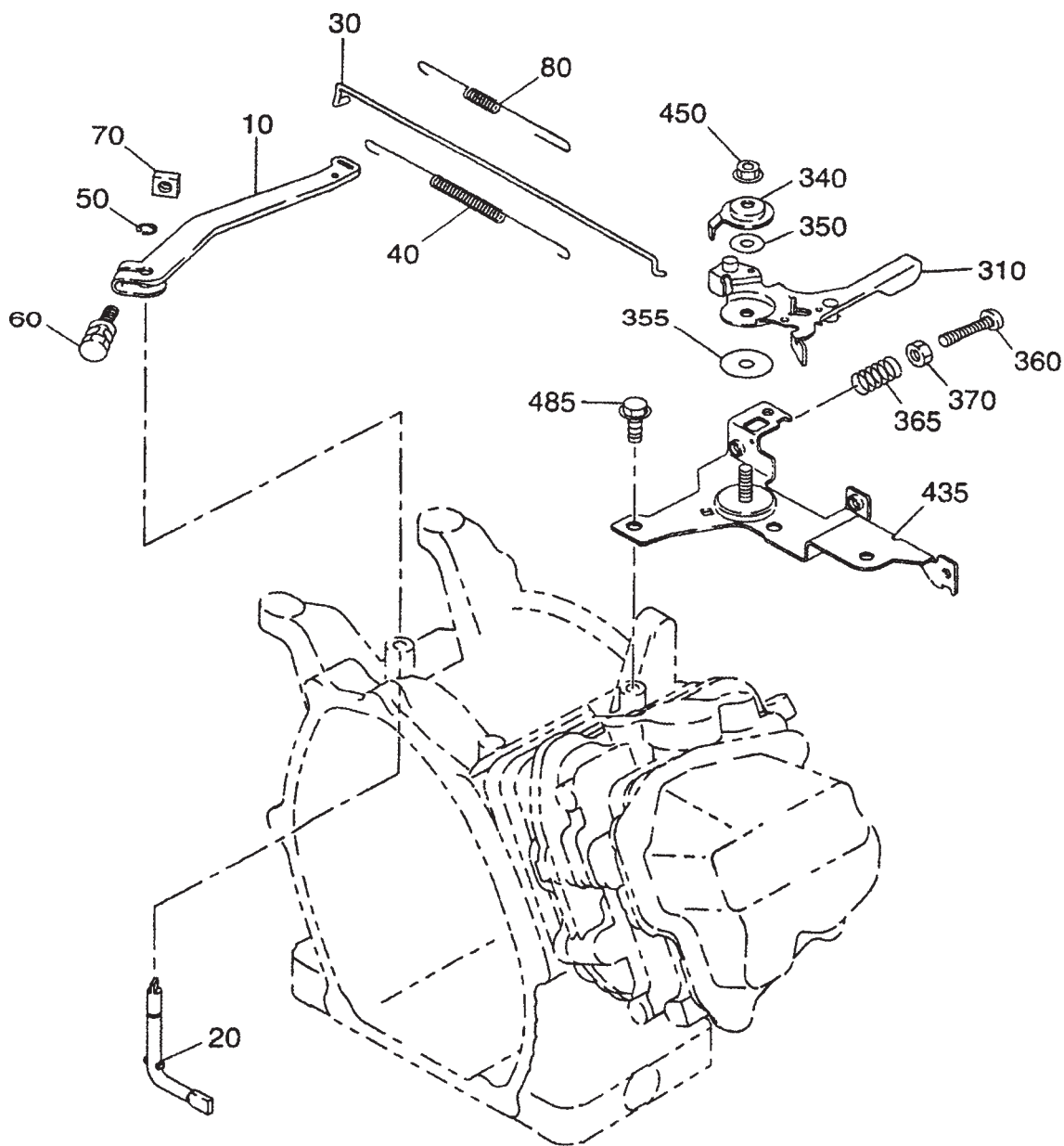

## GOVERNOR ASSY.

<b><u>NO</u></b>	<b><u>PART NO</u></b>	<b><u>PART NAME</u></b>	<b><u>QTY.</u></b>	<b><u>REMARKS</u></b>
10	2774230113	GOVERNOR, LEVER	1	
20	2774220133	GOVERNOR, SHAFT	1	
30	2774270101	GOVERNOR, ROD	1	
40	2774280113	ROD, SPRING	1	
50	0031305000	CLIP	1	
60	0130060240	BOLT & WASHER ASSY	1	
70	0186060020	NUT	1	
80	2794250223	GOVERNOR, SPRING	1	
310	2774330113	SPEED CONTROL, LEVER	1	
340	2774350103	STOP, PLATE	1	
350	0200060170	WASHER	1	
355	0217060070	FRICTION, WASHER	1	
360	0140060180	SCREW	1	
365	2374500423	SPRING, ADJUST	1	
370	0021706000	NUT	1	
435	2774600101	SPEED, CONT. BRACKET	1	
450	0023506000	LOCK NUT	1	
485	0110060020	FLANGE, BOLT	2	

# EX-170D40050 — IGNITION COIL/FLYWHEEL ASSY.

ELECTRIC DEVICE ASSY.

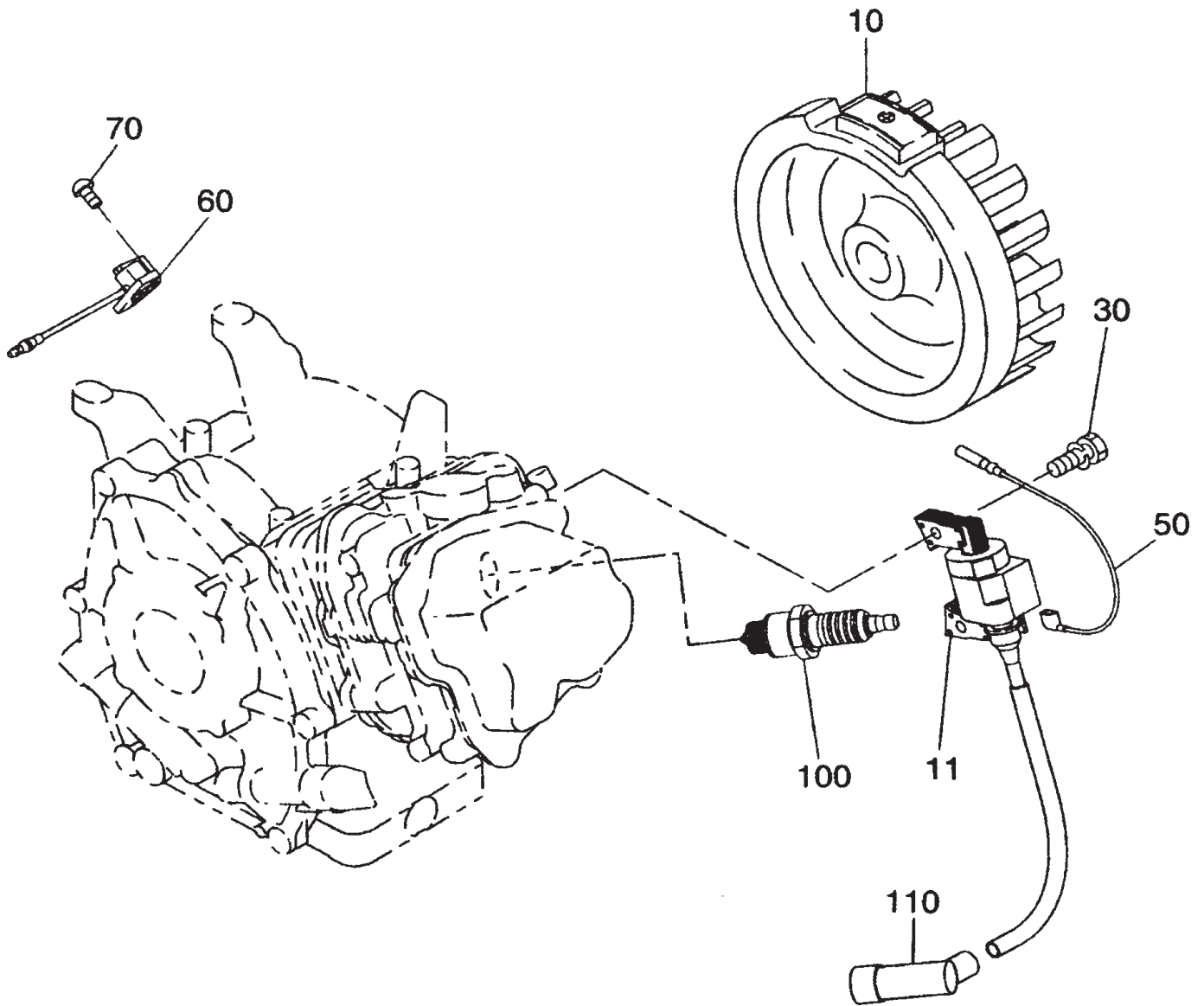

## EX-170D40050 — IGNITION COIL/FLYWHEEL ASSY.

ELECTRIC DEVICE ASSY.

<u>NO</u>	<u>PART NO</u>	<u>PART NAME</u>	<u>QTY.</u>	<u>REMARKS</u>
10	2777923001	FLYWHEEL	1	
11	2777943011	IGNITION COIL	1	
30	0011406250	BOLT & WASHER	2	
50	2777310101	WIRE 1	1	
60	X660000361	STOP SWITCH ASSY., ON-OFF	1	
70	0150040090	TAPPING SCREW	2	
100	0650140150	SPARK PLUG	1	
110	0655000270	SPARK PLUG CAP	1	

# EX-170D40050 — MUFFLER ASSY.

MUFFLER ASSY.

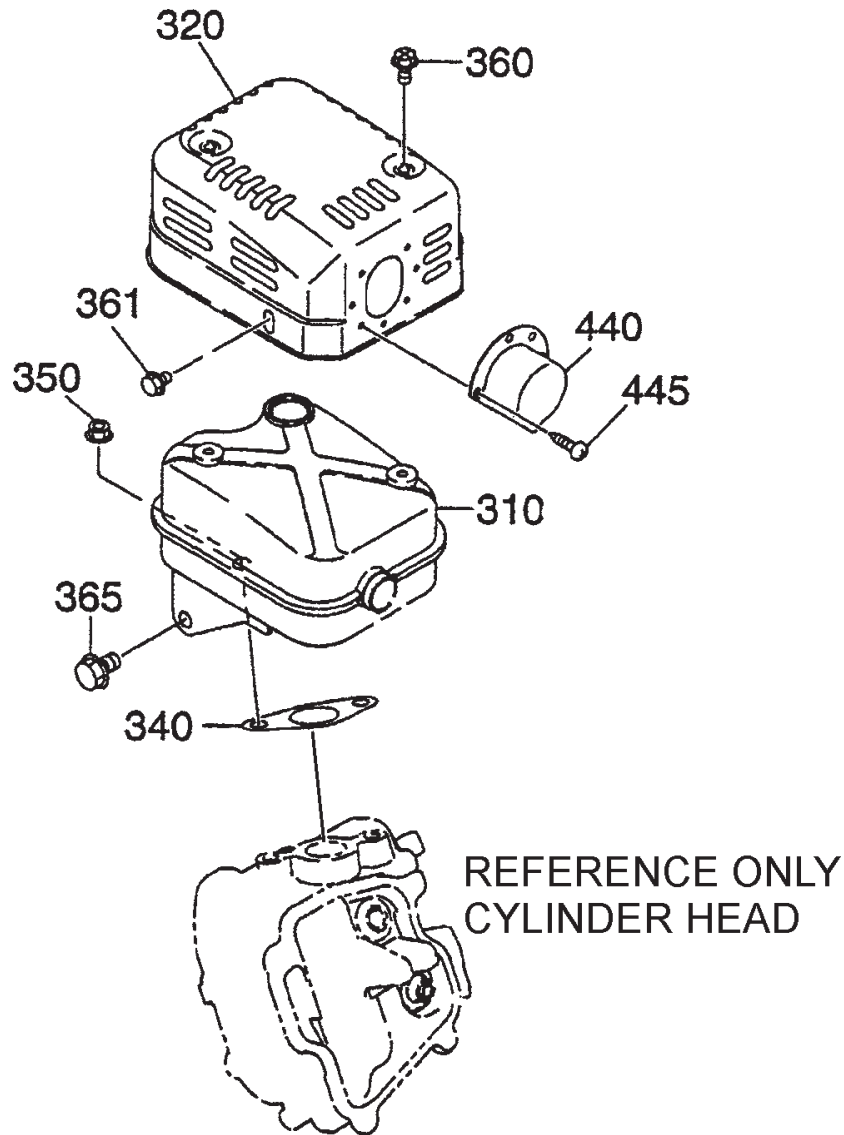



## EX-170D40050 — MUFFLER ASSY.

MUFFLER ASSY.

<u>NO</u>	<u>PART NO</u>	<u>PART NAME</u>	<u>QTY.</u>	<u>REMARKS</u>
310	2773010111	MUFFLER	1	
320	2773420111	MUFFLER COVER	1	
340	2773520103	GASKET, MUFFLER	1	
350	9802008280	FLANGE, NUT	2	
360	0152060090	TAPPING BOLT	2	
361	0110060010	FLANGE BOLT	1	
365	0110080150	FLANGE BOLT	1	
440	2773700101	DEFLECTOR	1	
445	0150040060	TAPPING SCREW	2	

# EX-170D40050 — RECOIL STARTER ASSY.

COOLING AND STARTING ASSY.

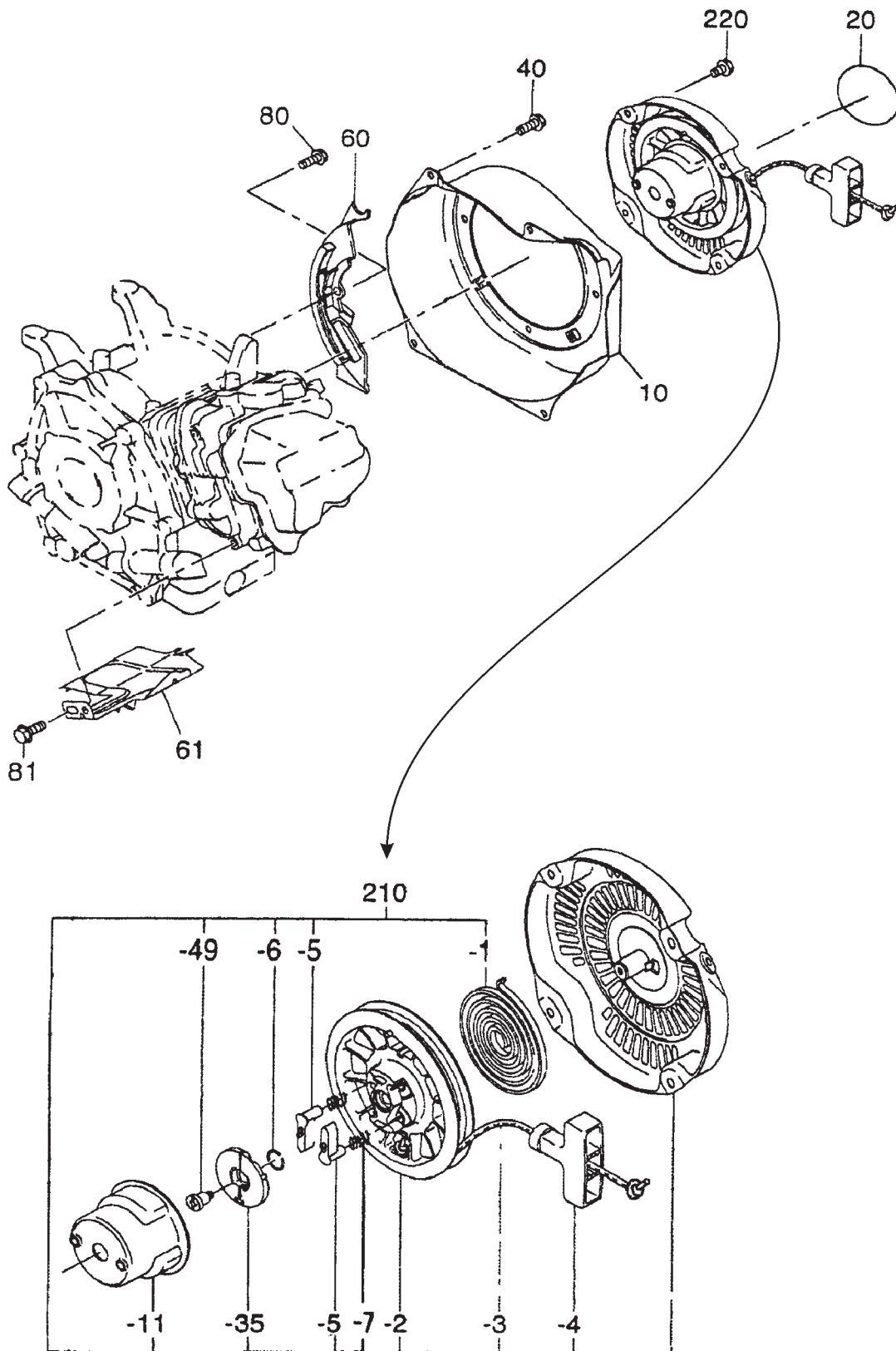

# EX-170D40050 — RECOIL STARTER ASSY.

## COOLING AND STARTING ASSY.

<u>NO</u>	<u>PART NO</u>	<u>PART NAME</u>	<u>QTY.</u>	<u>REMARKS</u>
10	2775120201	BLOWER, HOUSING CP	1	
20	0732005140	LABEL, TRADEMARK	1	
40	0110060030	FLANGE, BOLT	4	
60	2775271111	BAFFLE, CASE 1	1	
61	2775270203	BAFFLE, HEAD 2	1	
80	0010406160	FLANGE, BOLT	1	
81	0110060020	FLANGE, BOLT	1	
210	2695020130	RECOIL STARTER ASSY. ....	1	INCLUDES ITEMS W/*
210-1*	2705011508	SPIRAL, SPRING	1	
210-2*	2695012008	REEL	1	
210-3*	2825011118	STARTER ROPE	1	
210-4*	2615010008	STARTER KNOB	1	
210-5*	2705012508	RACHET	2	
210-6*	2275013108	FRICTION SPRING	1	
210-7*	2275013508	RETURN SPRING	2	
210-11*	2695014518	STARTER PULLEY	1	
210-35*	2705026108	RACHET GUIDE	1	
210-49*	2275015208	SET SCREW	1	
220	0110060010	FLANGE, BOLT	1	

**PAYMENT TERMS**

Terms of payment for parts are net 10 days.

**FREIGHT POLICY**

All parts orders will be shipped collect or prepaid with the charges added to the invoice. All shipments are F.O.B. point of origin. Multiquip's responsibility ceases when a signed manifest has been obtained from the carrier, and any claim for shortage or damage must be settled between the consignee and the carrier.

**MINIMUM ORDER**

The minimum charge for orders from Multiquip is \$15.00 net. Customers will be asked for instructions regarding handling of orders not meeting this requirement.

**RETURNED GOODS POLICY**

Return shipments will be accepted and credit will be allowed, subject to the following provisions:

1. A Returned Material Authorization must be approved by Multiquip prior to shipment.
2. To obtain a Return Material Authorization, a list must be provided to Multiquip Parts Sales that defines item numbers, quantities, and descriptions of the items to be returned.
  - a. The parts numbers and descriptions must match the current parts price list.
  - b. The list must be typed or computer generated.
  - c. The list must state the reason(s) for the return.
  - d. The list must reference the sales order(s) or invoice(s) under which the items were originally purchased.
  - e. The list must include the name and phone number of the person requesting the RMA.
3. A copy of the Return Material Authorization must accompany the return shipment.
4. Freight is at the sender's expense. All parts must be returned freight prepaid to Multiquip's designated receiving point.

5. Parts must be in new and resalable condition, in the original Multiquip package (if any), and with Multiquip part numbers clearly marked.

6. The following items are not returnable:

- a. Obsolete parts. (If an item is in the price book and shows as being replaced by another item, it is obsolete.)
- b. Any parts with a limited shelf life (such as gaskets, seals, "O" rings, and other rubber parts) that were purchased more than six months prior to the return date.
- c. Any line item with an extended dealer net price of less than \$5.00.
- d. Special order items.
- e. Electrical components.
- f. Paint, chemicals, and lubricants.
- g. Decals and paper products.
- h. Items purchased in kits.

7. The sender will be notified of any material received that is not acceptable.

8. Such material will be held for five working days from notification, pending instructions. If a reply is not received within five days, the material will be returned to the sender at his expense.

9. Credit on returned parts will be issued at dealer net price at time of the original purchase, less a 15% restocking charge.

10. In cases where an item is accepted, for which the original purchase document can not be determined, the price will be based on the list price that was effective twelve months prior to the RMA date.

11. Credit issued will be applied to future purchases only.

**PRICING AND REBATES**

Prices are subject to change without prior notice. Price changes are effective on a specific date and all orders received on or after that date will be billed at the revised price. Rebates for price declines and added charges for price increases will not be made for stock on hand at the time of any price change.

Multiquip reserves the right to quote and sell direct to Government agencies, and to Original Equipment Manufacturer accounts who use our products as integral parts of their own products.

**SPECIAL EXPEDITING SERVICE**

A \$35.00 surcharge will be added to the invoice for special handling including bus shipments, insured parcel post or in cases where Multiquip must personally deliver the parts to the carrier.

**LIMITATIONS OF SELLER'S LIABILITY**

Multiquip shall not be liable here under for damages in excess of the purchase price of the item with respect to which damages are claimed, and in no event shall Multiquip be liable for loss of profit or good will or for any other special, consequential or incidental damages.

**LIMITATION OF WARRANTIES**

No warranties, express or implied, are made in connection with the sale of parts or trade accessories nor as to any engine not manufactured by Multiquip. Such warranties made in connection with the sale of new, complete units are made exclusively by a statement of warranty packaged with such units, and Multiquip neither assumes nor authorizes any person to assume for it any other obligation or liability whatever in connection with the sale of its products. Apart from such written statement of warranty, there are no warranties, express, implied or statutory, which extend beyond the description of the products on the face hereof.



# OPERATION & PARTS MANUAL

## HERE'S HOW TO GET HELP

PLEASE HAVE THE MODEL AND SERIAL  
NUMBER *ON-HAND* WHEN CALLING

### UNITED STATES

#### **Multiquip Corporate Office**

18910 Wilmington Ave. Tel. (800) 421-1244  
Carson, CA 90746 Fax (800) 537-3927  
Contact: mq@multiquip.com

#### **Mayco Parts**

800-306-2926 Fax: 800-672-7877  
310-537-3700 Fax: 310-637-3284

#### **Service Department**

800-421-1244 Fax: 310-537-4259  
310-537-3700

#### **MQ Parts Department**

800-427-1244 Fax: 800-672-7877  
310-537-3700 Fax: 310-637-3284

#### **Warranty Department**

800-421-1244, Ext. 279 Fax: 310-537-1173  
310-537-3700, Ext. 279

#### **Technical Assistance**

800-478-1244 Fax: 310-631-5032

### MEXICO

#### **MQ Cipsa**

Carr. Fed. Mexico-Puebla KM 126.5 Tel: (52) 222-225-9900  
Momoxpan, Cholula, Puebla 72760 Mexico Fax: (52) 222-285-0420  
Contact: pmastretta@cipsa.com.mx

### CANADA

#### **Multiquip**

4110 Industriel Boul. Tel: (450) 625-2244  
Laval, Quebec, Canada H7L 6V3 Fax: (450) 625-8664  
Contact: jmartin@multiquip.com

### UNITED KINGDOM

#### **Multiquip (UK) Limited Head Office**

Hanover Mill, Fitzroy Street, Tel: 0161 339 2223  
Ashton-under-Lyne, Fax: 0161 339 3226  
Lancashire OL7 0TL  
Contact: sales@multiquip.co.uk

### BRAZIL

#### **Multiquip**

Av. Evandro Lins e Silva, 840 - grupo 505 Tel: 011-55-21-3433-9055  
Barra de Tijuca - Rio de Janeiro Fax: 011-55-21-3433-9055  
Contact: cnavarro@multiquip.com.br, srentes@multiquip.com.br

© COPYRIGHT 2005, MULTIQUIP INC.

Multiquip Inc., Mikasa, and the MQ logo are registered trademarks of Multiquip Inc. and may not be used, reproduced, or altered without written permission. All other trademarks are the property of their respective owners and used with permission.

This manual MUST accompany the equipment at all times. This manual is considered a permanent part of the equipment and should remain with the unit if resold.

The information and specifications included in this publication were in effect at the time of approval for printing. Illustrations are based on the *MVC-70E/EW Plate Compactor*. Illustrations, descriptions, references and technical data contained in this manual are for guidance only and may not be considered as binding. Multiquip Inc. reserves the right to discontinue or change specifications, design or the information published in this publication at any time without notice and without incurring any obligations.

Your Local Dealer is:



## Free Manuals Download Website

<http://myh66.com>

<http://usermanuals.us>

<http://www.somanuals.com>

<http://www.4manuals.cc>

<http://www.manual-lib.com>

<http://www.404manual.com>

<http://www.luxmanual.com>

<http://aubethermostatmanual.com>

Golf course search by state

<http://golfingnear.com>

Email search by domain

<http://emailbydomain.com>

Auto manuals search

<http://auto.somanuals.com>

TV manuals search

<http://tv.somanuals.com>