

# PARTS AND OPERATION MANUAL



## GAS POWERED TRASH PUMP MODEL QP40TH (HONDA)

© COPYRIGHT 2002, MULTIQUIP INC.

Revision #1 (10/01/02)



**MULTIQUIP INC.**

18910 WILMINGTON AVE.  
CARSON, CALIFORNIA 90746  
310-537-3700  
800-421-1244  
FAX: 310-537-3927

**E-mail:** [mq@multiquip.com](mailto:mq@multiquip.com) • **www:** [www.multiquip.com](http://www.multiquip.com)

Atlanta • Boise • Dallas • Houston • Newark  
Montreal, Canada • Manchester, UK  
Rio De Janeiro, Brazil • Guadalajara, Mexico

**PARTS DEPARTMENT:**

800-427-1244  
FAX: 800-672-7877

**SERVICE DEPARTMENT/TECHNICAL ASSISTANCE:**

800-478-1244  
FAX: 310-631-5032



# WARNING

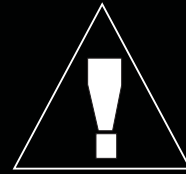

## **CALIFORNIA — Proposition 65 Warning**

Engine exhaust and some of its constituents are known to the State of California to cause cancer, birth defects and other reproductive harm.

## **HERE'S HOW TO GET HELP**

*PLEASE HAVE THE MODEL AND SERIAL NUMBER  
ON-HAND WHEN CALLING*

### ***PARTS DEPARTMENT***

*800-427-1244 or 310-537-3700*

*FAX: 800-672-7877 or 310-637-3284*

### ***SERVICE DEPARTMENT/TECHNICAL ASSISTANCE***

*800-478-1244 or 310-537-3700*

*FAX: 310- 537-4259*

### ***WARRANTY DEPARTMENT***

*888-661-4279, or 310-661-4279*

*FAX: 310- 537-1173*

### ***MAIN***

*800-421-1244 or 310-537-3700*

*FAX: 310-537-3927*

# TABLE OF CONTENTS

Here's How To Get Help ..... 3  
 Table Of Contents ..... 4  
 Parts Ordering Procedures ..... 5

## Multiquip QP40TH Trash Pump

Safety Message Alert Symbols ..... 6-7  
 Rules For Safe Operation ..... 8-9  
 Pump Specifications/Dimensions ..... 10  
 Engine Specifications ..... 11  
 General Information ..... 12  
 Pump Components ..... 13  
 Basic Engine ..... 14  
 Pre-Inspection (Engine) ..... 15  
 Pre-Set-up (Pump) ..... 16  
 Initial Start-up (Engine) ..... 17-18  
 Maintenance (Pump) ..... 20-21  
 Maintenance (Engine) ..... 22-23  
 Preparation for Long-Term Storage ..... 24  
 Troubleshooting (Pump) ..... 26  
 Troubleshooting (Pump/Engine) ..... 27  
 Explanation Of Code In Remarks Column ..... 28  
 Suggested Spare Parts ..... 29  
 Pump Assy. .... 30-33

## Honda GX340K1QA2 Engine

Air Cleaner Assy. .... 34-35  
 Camshaft Assy. .... 36-37  
 Piston Assy. .... 38-39  
 Crankcase Cover Assy. .... 40-41  
 Crankshaft Assy. .... 42-43  
 Cylinder Barrel Assy. .... 44-45  
 Cylinder Head ..... 46-47  
 Fan Cover Assy. .... 48-49  
 Flywheel Assy. .... 50-51  
 Fuel Tank Assy. .... 52-53  
 Ignition Coil Assy. .... 54-55  
 Carburetor Assy. .... 56-59  
 Muffler Assy. .... 60-61  
 Recoil Starter Assy. .... 62-63  
 Control Assy. .... 64-65  
 Labels Assy. .... 66-67  
  
 Terms and Conditions of Sale ..... 68

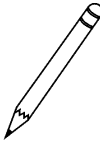
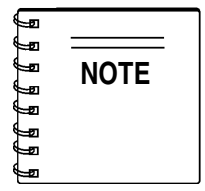

**Specification and part number are subject to change without notice.**

- Dealer account number
- Dealer name and address
- Shipping address (if different than billing address)
- Return fax number
- Applicable model number
- Quantity, part number and description of each part
- Specify preferred method of shipment:
  - UPS Ground
  - UPS Second Day or Third Day\*
  - UPS Next Day\*
  - Federal Express Priority One (please provide us with your Federal Express account number)\*
  - Airborne Express\*
  - Truck or parcel post

*\*Normally shipped the same day the order is received, if prior to 2PM west coast time.*

## Earn Extra Discounts when you order by FAX!

All parts orders which include complete part numbers and are received by fax qualify for the following extra discounts:

<u>Number of line items ordered</u>	<u>Additional Discount</u>
1-9 items	3%
10+ items**	5%

### Get special freight allowances when you order 10 or more line items via FAX! \*\*

- UPS Ground Service at no charge for freight
- UPS Third Day Service at one-half of actual freight cost

No other allowances on freight shipped by any other carrier.

\*\*Common nuts, bolts and washers (all items under \$1.00 list price) do not count towards the 10+ line items.

\*DISCOUNTS ARE SUBJECT TO CHANGE\*

Fax order discount and UPS special programs revised June 1, 1995

**Extra Fax Discount  
for Domestic USA  
Dealers Only**

**Up to 5%  
extra savings!**

**UPS  
Special**  
For faxed orders only

**Now! Direct TOLL-FREE access  
to our Parts Department!**

Toll-free nationwide:

**800-421-1244**

Toll-free FAX:

**800/6-PARTS-7 • 800-672-7877**

# QP40TH — SAFETY MESSAGE ALERT SYMBOLS

## FOR YOUR SAFETY AND THE SAFETY OF OTHERS!

Safety precautions should be followed at all times when operating this equipment. Failure to read and understand the Safety Messages and Operating Instructions could result in injury to yourself and others.

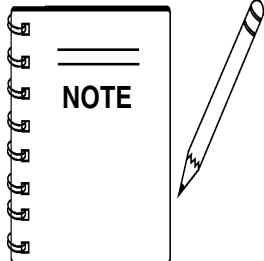

This Owner's Manual has been developed to provide complete instructions for the safe and efficient operation of the Multiqui pModel **QP40TH Centrifugal Trash Pump**. Refer to the engine manufacturers instructions for data relative to its safe operation.

**Before using these pumps, ensure that the operating individual has read and understands all instructions in this manual.**

## SAFETY MESSAGE ALERT SYMBOLS

The three (3) Safety Messages shown below will inform you about potential hazards that could injure you or others. The Safety Messages specifically address the level of exposure to the operator, and are preceded by one of three words: **DANGER**, **WARNING**, or **CAUTION**.



**DANGER:** You **WILL** be **KILLED** or **SERIOUSLY** injured if you do not follow directions.



**WARNING:** You **CAN** be **KILLED** or **SERIOUSLY** injured if you do not follow directions.

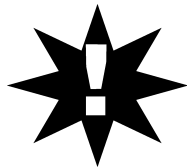

**CAUTION:** You **CAN** be injured if you do not follow directions.

Potential hazards associated with the QP-40TH Centrifugal Trash Pump operation will be referenced with Hazard Symbols which appear throughout this manual, and will be referenced in conjunction with Safety Message Alert Symbols.

## HAZARD SYMBOLS



### Lethal Exhaust Gases



Engine exhaust gases contain poisonous carbon monoxide. This gas is colorless and odorless, and can cause death if inhaled. **NEVER** operate this equipment in a confined area or enclosed structure that does not provide ample free flow air.



### Explosive Fuel

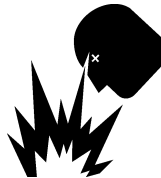

**GASOLINE** is extremely flammable, and its vapors can cause an explosion if ignited. **DO NOT** start the engine near spilled fuel or combustible fluids. **DO NOT** fill the fuel tank while the engine is running or hot. **DO NOT** overfill tank, since spilled fuel could ignite if it comes into contact with hot engine parts or sparks from the ignition system. Store fuel in approved containers, in well-ventilated areas and away from sparks and flames. **NEVER** use fuel as a cleaning agent.



### Burn Hazards



Engine components can generate extreme heat. To prevent burns, **DO NOT** touch these areas while the engine is running or immediately after operations. Never operate the engine with heat shields or heat guards removed.



### Rotating Parts



**NEVER** operate equipment with covers, or guards removed. Keep fingers, hands, hair and clothing away from all moving parts to prevent injury.

# QP40TH — SAFETY MESSAGE ALERT SYMBOLS



## Accidental Starting



OFF

**ALWAYS** place the engine ON/OFF switch in the **OFF** position when the pump is not in use.



## Respiratory Hazard



**ALWAYS** wear approved respiratory protection.



## Sight and Hearing hazard

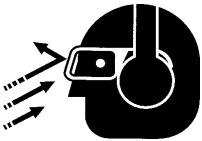

**ALWAYS** wear approved eye and hearing protection.



## Equipment Damage Messages

Other important messages are provided throughout this manual to help prevent damage to your pump, other property, or the surrounding environment.

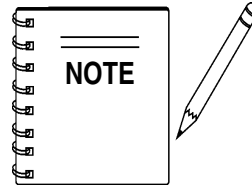

This pump, other property, or the surrounding environment could be damaged if you do not follow instructions.

# RULES FOR SAFE OPERATION

## DANGER:



Failure to follow instructions in this manual may lead to serious injury or even death! This equipment is to be operated by trained and qualified personnel only! This equipment is for industrial use only.

The following safety guidelines should always be used when operating the **trash pump**:

### GENERAL SAFETY

- **DO NOT** operate or service this equipment before reading this entire manual.



- This equipment should not be operated by persons under 18 years of age.

- **NEVER** operate this equipment without proper protective clothing, shatterproof glasses, steel-toed boots and other protective devices required by the job.



- **NEVER** operate this equipment when not feeling well due to fatigue, illness or taking medicine.



- **NEVER** operate this equipment under the influence of drugs or alcohol.



- Whenever necessary, replace nameplate, operation and safety decals when they become difficult read.

- **ALWAYS** check the machine for loosened threads or bolts before starting.

- **ALWAYS** wear proper respiratory (mask) hearing and eye protection equipment when operating the pump.



- **NEVER** touch the hot exhaust manifold, muffler or cylinder. Allow these parts to cool before servicing engine or pump.



- **High Temperatures** – Allow the engine to cool before adding fuel or performing service and maintenance functions. Contact with *hot* components can cause serious burns.

- The engine of this pump requires an adequate free flow of cooling air. **NEVER!** operate the roller in any enclosed or narrow area where free flow of the air is restricted. If the air

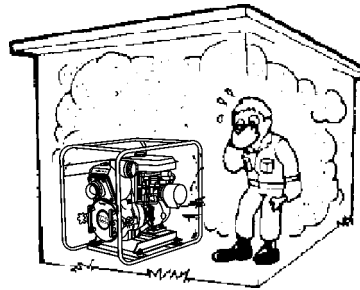

flow is restricted it will cause serious damage to the pump or engine and may cause injury to people and property. Remember the pump's engine (gasoline models only) gives off **DEADLY** gases.

- **ALWAYS** refuel in a well-ventilated area, away from sparks and open flames.

- **ALWAYS** use extreme caution when working with **flammable** liquids. When refueling, **stop the engine** and allow it to cool. **DO NOT** smoke around or near the machine. Fire or explosion could result from fuel vapors, or if fuel is spilled on a hot engine.

- **NEVER** operate the pump in an **explosive atmosphere** or near combustible materials. An explosion or fire could result causing severe **bodily harm or even death**.

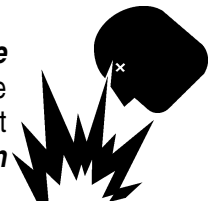

- Topping-off to filler port is dangerous, as it tends to spill fuel.

- Refer to the **Engine Owner's Manual** for engine technical questions or information.

- **NEVER** use accessories or attachments, which are not recommended by Multiquip for this equipment. Damage to the equipment and/or injury to user may result.

- Manufacturer does not assume responsibility for any accident due to equipment modifications.



# RULES FOR SAFE OPERATION

- **NEVER** Run engine without air cleaner. Severe engine damage may occur.
- **ALWAYS** read, understand, and follow procedures in Operator's Manual before attempting to operate equipment.
- **ALWAYS** be sure the operator is familiar with proper safety precautions and operation techniques before using pump.
- **ALWAYS** store equipment properly when it is not being used. Equipment should be stored in a clean, dry location out of the reach of children.
- **NEVER** leave the pump unattended, turn off engine when unattended.
- Unauthorized equipment modifications will void all warranties.
- **NEVER** pump volatile, explosive, flammable or low flash point fluids. These fluids could ignite or explode.
- **NEVER** operate the pump in an **explosive** atmosphere.
- Before starting the pump, check that the clean-out cover is securely fasten.
- **ALWAYS** ensure pump is on level ground before use.
- Become familiar with the components of the pump before operating.
- **ALWAYS** replace any worn or damaged warning decals.
- **NEVER** pump corrosive chemicals or water containing toxic substances. These fluids could create serious health and environmental hazards. Contact local authorities for assistance.
- **NEVER** open the priming plug when pump is hot. Hot water inside could be pressurized much like the radiator of an automobile. Allow pump to cool to the touch before loosening plug.
- **NEVER** open the pump housing during operation or start the pump with the clean-out cover removed. The rotating impeller inside the pump can cut or sever objects caught in it.
- **NEVER** block or restrict flow from discharge hose. Remove kinks from discharge line before starting pump. Operation with a blocked discharge line can cause water inside pump to overheat.
- **ALWAYS** fill the pump casing with water before starting the engine. Failure to maintain water inside the pump housing will cause severe damage to the pump.
- In winter drain water from pump housing to prevent freezing.

■ **High Temperatures** – Always stop engine and allow the engine to cool before adding fuel, oil or performing service and maintenance functions. Contact with *hot* components can cause serious burns.

■ **NEVER** disconnect any "**emergency or safety devices**". These devices are intended for operator safety. Disconnection of these devices can cause severe injury, bodily harm or even death! Disconnection of any of these devices will void all warranties.

## Maintenance Safety

- **NEVER** lubricate components or attempt service on a running machine.
- **ALWAYS** allow the machine a proper amount of time to cool before servicing.
- Keep the machinery in proper running condition.
- Fix damage to the machine immediately and always replace broken parts, or missing decals.
- Dispose of hazardous waste properly. Examples of potentially hazardous waste are used motor oil, fuel and fuel filters.
- **DO NOT** use food or plastic containers to dispose of hazardous waste.
- **DO NOT** pour waste, oil or fuel directly onto the ground, down a drain or into any water source.

## Emergencies

■ **ALWAYS** know the location of the nearest **fire extinguisher**.



■ **ALWAYS** know the location of the nearest **first aid kit**.



■ In emergencies **always** know the location of the nearest phone or **keep a phone on the job site**. Also know the phone numbers of the nearest **ambulance**, **doctor** and **fire department**. This information will be invaluable in the case of an emergency.

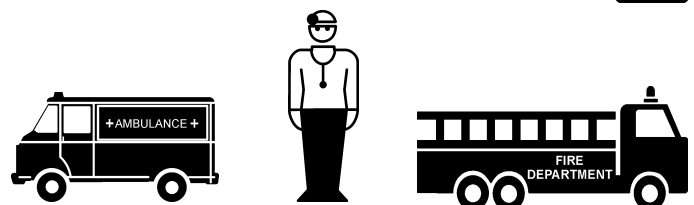

# QP40TH — SPECIFICATIONS/DIMENSIONS (PUMP)

**Table 1. Specifications (Pump)**

Pump	Model	QP-40TH
	Type	Centrifugal Trash Pump
	Suction & Discharge Size	4.00 in. (102 mm.)
	Maximum Pumping Capacity	611 gallons/minute (2,313 liters/minute)
	Max. Solids Diameter	2.00 in. (51 mm.)
	Max. Lift	25 ft. (7.62 meters)
	Max. Head	90 ft. (27.43 meters)
Dimension (L x W x H)		27.0 x 25.0 X 28.5 in. (68 X 63 X 72 cm.)
Dry Net Weight		220 lbs. (99 Kg.)

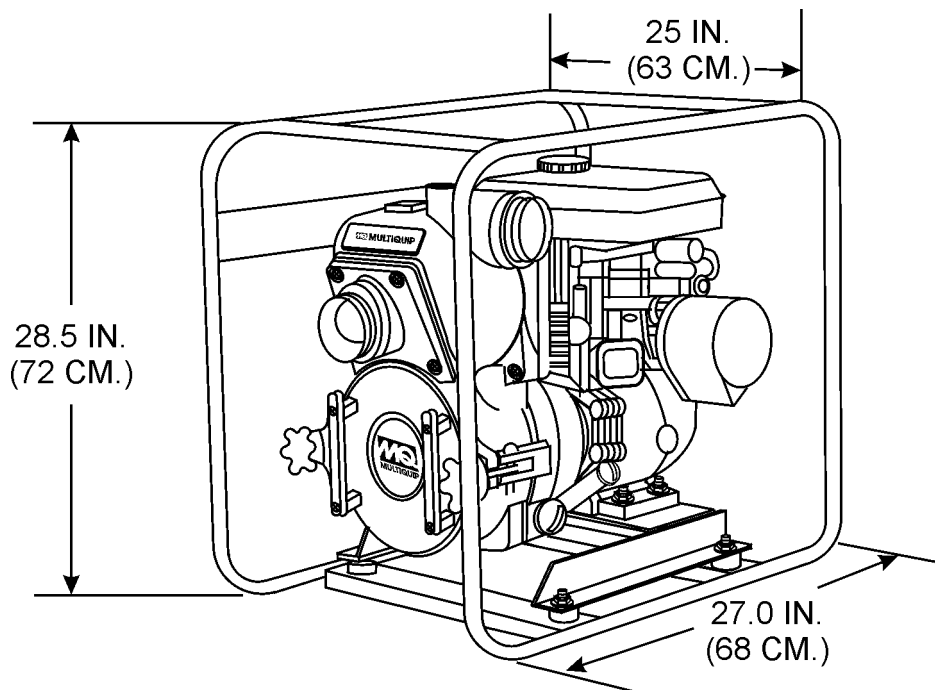

**Figure 1. QP-40TH Pump Dimensions**

## Table 2. Specifications (Engine)

Table 2. Specifications (Engine)		
Engine	Model	HONDA GX340K1QA2
	Type	Air-cooled 4 stroke, Single Cylinder, OHV, Horizontal Shaft Gasoline Engine
	Bore X Stroke	2.90 in. X 2.30 in. (73 mm x 58 mm.)
	Displacement	23.70 cu-in (389 cm <sup>3</sup> )
	Max Output	11.0 H.P./3600 R.P.M.
	Fuel Tank Capacity	1.72 gallons (6.5 liters)
	Fuel	Unleaded Automobile Gasoline
	Lube Oil Capacity	1.16 quarts (1.1 liters)
	Oil Alert System	Yes
	Speed Control Method	Centrifugal Fly-weight Type
	Starting Method	Recoil Start
Dimension (L x W x H)	15.0 x 17.7 X 17.4 in. (380 X 450 X 443 mm.)	
Dry Net Weight	68.4 lbs (31 Kg.)	

## APPLICATION

The **QP40TH Centrifugal Trash Pump** is designed to be used for de-watering applications. Both the suction and discharge ports on the QP40TH pump use a 4-inch diameter opening, which allows the pump to pump at a rate of approximately 611 gallons/minute (gpm) or 2,313 liters/minute (lpm).

Centrifugal or self priming pumps are designed to purge air from the suction line and create a partial vacuum in the pump body. The reduced atmospheric pressure inside the pump allows water to flow through the suction line and into the pump body. The centrifugal force created by the rotating impeller pressurizes the water and expels it from the pump.

## Power Plant

This trash pump is powered by an 11 horsepower air cooled 4-stroke, single cylinder **HONDA GX-340** gasoline engine that incorporates a low "**Oil Alert Feature**"

## Oil Alert Feature

In the event of **low oil** or **no oil**, the HONDA GX-340 engine has a built-in oil alarm engine shut-down feature. In the event the oil level is low the engine will automatically shut-down.

## Trash Pump

Trash pumps derive their name from their ability to handle a greater amount of debris and solids than standard centrifugal pumps. These pumps generally handle solids up to 1/2 the size of the discharge opening making them less likely to clog. Also trash pumps are capable of handling water with 25% solids by weight.

The advantage of using a trash pump is that it can be quickly and easily disassembled in the field "**without tools**" and easily cleaned when clogged.

## Suction Lift

This pump is intended to be used for dewatering applications and is capable of suction lifts up to 25 feet at sea level. For optimal suction lift performance keep the suction hose or line as short as possible. In general always put the pump as close to the water as possible.

## Pump Support

The pump should always be placed on **solid stationary ground** in a level position.

**NEVER** place the pump on **soft soil**. The suction hose or pipe connection should always be checked for tightness and leaks. A small suction leak in the hose or fittings could prevent the pump from priming.

## Elevation

Elevations over 3,000 feet will effect the performance of the pump. Due to less atmospheric pressure at higher altitudes, pumps **DO NOT** have the priming ability that they have at sea level.

A general rule of thumb is that for every 1,000 feet of elevation above sea level a pump will lose one foot of priming ability.

For example, in Flagstaff, Arizona where the elevation is approximately 7,000 feet, the pump would have a suction lift of only 18 feet rather than the 25 feet at sea level.

## QP40TH — PUMP COMPONENTS

Figure 2 shows a typical application using the QP40TH Centrifugal Trash pump. Please note that this pump is intended for the removal of clean water and water containing some debris and solids. Maximum size of solids should not exceed 2 inches (50 mm) in diameter. **DO NOT** set strainer on bottom of water bed. Placing the strainer above the water bed will prevent the pump from drawing in excessive amounts of sand and foreign debris.

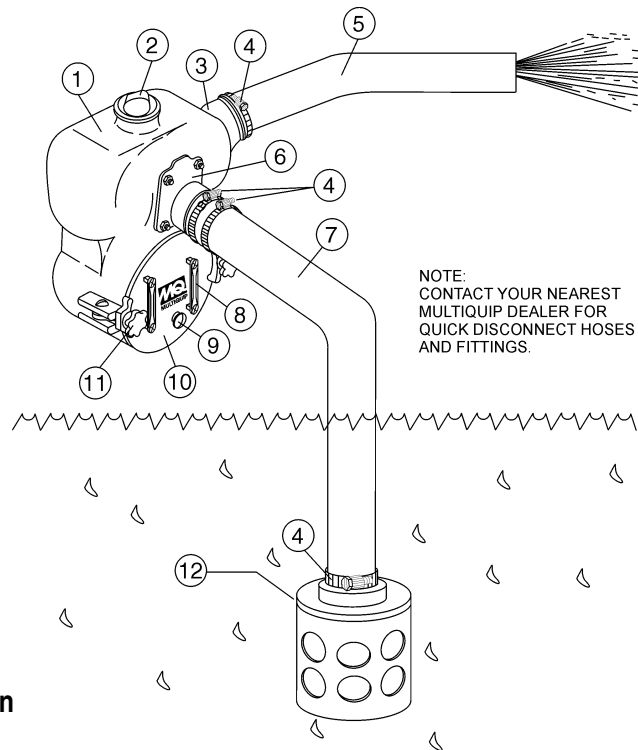
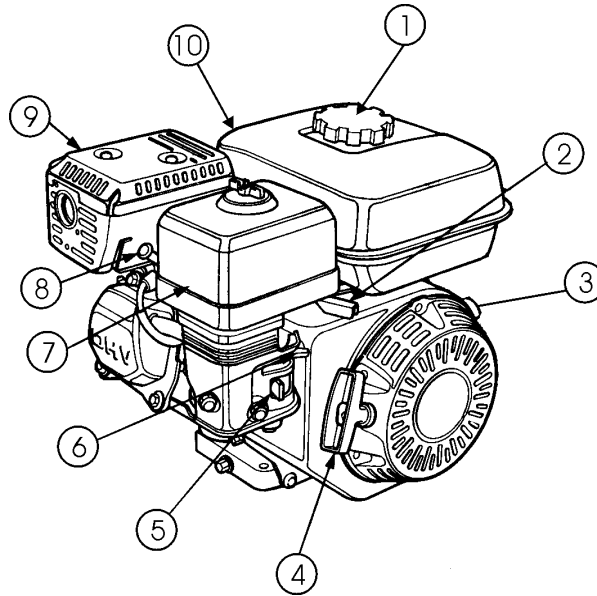

Figure 2. QP-40TH Pump Application

- 1. Pump** – The model MQ40TDH is 4-inch trash pump used in general de-watering applications. Typical dewatering applications consist of manholes, septic tanks, fast and slow seepage ditch water, silt water, mud water and muck water.
- 2. Fill Cap** – Prior to operation, the pump casing should be filled with water. Remove this cap to add water to the pump. After the initial prime, a sufficient amount of water will be retained in the casing so that the operator will not need to re-prime later.  
  
If the casing is dry or has insufficient water, the pump will have difficulty in priming which could lead to premature mechanical seal wear thus causing damage to the pump.
- 3. Discharge Port** – Connect a 4-inch discharge hose to this port.
- 4. Worm Clamp** – Used to secure the hose to the inlet and outlet ports on the pump. Use two clamps to secure the hose on the inlet side of the pump.
- 5. Discharge Hose** – Connect this flexible rubber hose to the discharge port on the pump. Make sure that the hose lays flat and is not kinked. Use only recommended type discharge hose. Contact Multiquip parts department for ordering information.
- 6. Suction Port** – Connect a 4-inch inlet hose to this port. Use two worm clamps to secure the hose.
- 7. Suction Hose** – Connect this flexible rubber hose to the suction port on the pump. Make sure that the hose lays flat and is not kinked. Use only recommended type suction hose. Contact Multiquip parts department for ordering information.
- 8. Clean-out Cover Handles** – To gain access to the pump's clean-out area, grip both handles, then pull to remove cover. Make sure both locking knobs have been released before attempting to remove clean-out cover.
- 9. Drain Plug** – Remove this plug to drain water from the pump.
- 10. Clean-out Cover** – Remove cover to gain access to the clean-out area.
- 11. Locking Knobs** – Turn both knobs clockwise to secure clean-out cover, turn counter-clockwise to release cover.
- 12. Strainer** – Always attach a strainer to bottom side of the suction hose to prevent large objects and debris from entering the pump. Strainer should be positioned so that it will remain completely under water. Running the pump with the strainer above water for long periods can damage pump.



**Figure 3. Engine Controls and Components**

## INITIAL SERVICING

The engine (Figure 3) must be checked for proper lubrication and filled with fuel prior to operation. Refer to the manufacturer's engine manual for instructions & details of operation and servicing. The engine shown above is a **HONDA** engine, operation for other types of engines may vary somewhat.

1. **Fuel Filler Cap** – Remove this cap to add unleaded gasoline to the fuel tank. Make sure cap is tightened securely. **DO NOT** over fill.



**DANGER**

Adding fuel to the tank should be done only when the engine is stopped and has had an opportunity to cool down. In the event of a fuel spill, **DO NOT** attempt to start the engine until the fuel residue has been completely wiped up, and the area surrounding the engine is dry.

2. **Throttle Lever** – Used to adjust engine RPM speed (lever advanced forward **SLOW**, lever back toward operator **FAST**).
3. **Engine ON/OFF Switch** – ON position permits engine starting, OFF position stops engine operations.
4. **Recoil Starter (pull rope)** – Manual-starting method. Pull the starter grip until resistance is felt, then pull briskly and smoothly.
5. **Fuel Valve Lever** – **OPEN** to let fuel flow, **CLOSE** to stop the flow of fuel.

6. **Choke Lever** – Used in the starting of a cold engine, or in cold weather conditions. The choke enriches the fuel mixture.
7. **Air Cleaner** – Prevents dirt and other debris from entering the fuel system. Remove wing-nut on top of air filter canister to gain access to filter element.

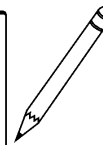
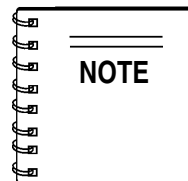

Operating the engine without an air filter, with a damaged air filter, or a filter in need of replacement will allow dirt to enter the engine, causing rapid engine wear.

8. **Spark Plug** – Provides spark to the ignition system. Set spark plug gap to 0.6 - 0.7 mm (0.028 - 0.031 inch) Clean spark plug once a week.
9. **Muffler** – Used to reduce noise and emissions.



**WARNING**

Engine components can generate extreme heat. To prevent burns, **DO NOT** touch these areas while the engine is running or immediately after operating. **NEVER** operate the engine with the muffler removed.

10. **Fuel Tank** – Holds unleaded gasoline. For additional information refer to engine owner's manual.

## CAUTION

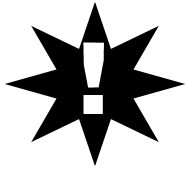

**NEVER** operate the pump in a confined area or enclosed area structure that does not provide ample **free flow of air**.



**ALWAYS** wear approved eye and hearing protection before operating the pump.

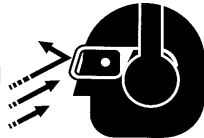

## Before Starting

1. Read safety instructions at the beginning of manual.
2. Clean the pump, removing dirt and dust, particularly the engine cooling air inlet, carburetor and air cleaner.
3. Check the air filter for dirt and dust. If air filter is dirty, replace air filter with a new one as required.
4. Check carburetor for external dirt and dust. Clean with dry compressed air.
5. Check fastening nuts and bolts for tightness.



## Engine Oil Check

1. To check the engine oil level, place the pump on secure level ground with the engine stopped.
2. Remove the filler dipstick from the engine oil filler hole (Figure 4) and wipe clean.

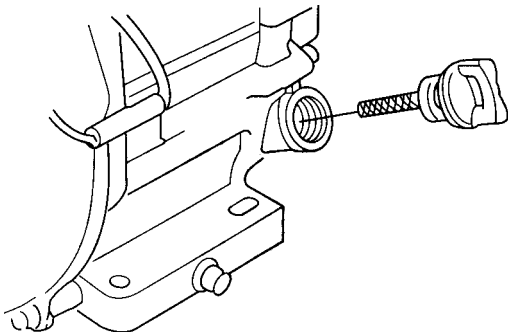

Figure 4. Engine Oil Dipstick (Removal)

3. Insert and remove the dipstick without screwing it into the filler neck. Check the oil level shown on the dipstick.
4. If the oil level is low (Figure 5), fill to the edge of the oil filler hole with the recommended oil type (Table 3). Maximum oil capacity is 1.16 quarts (1.1 liters)

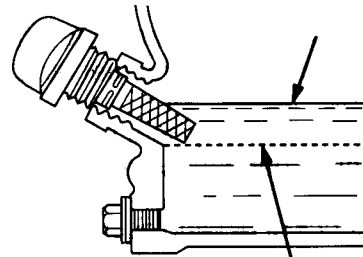

Figure 5. Engine Oil Dipstick (Oil Level)

Table 3. Oil Type

Season	Temperature	Oil Type
Summer	25°C or Higher	SAE 10W-30
Spring/Fall	25°C~10°C	SAE 10W-30/20
Winter	0°C or Lower	SAE 10W-10

**Explosive Fuel**

**DANGER**



Motor fuels are highly flammable and can be dangerous if mishandled. **DO NOT** smoke while refueling. **DO NOT** attempt to refuel the pump if the engine is **hot!** or **running**.

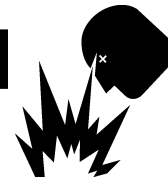

## Fuel Check

1. Remove the gasoline cap located on top of fuel tank.
2. Visually inspect to see if the fuel level is low. If fuel is low, replenish with unleaded fuel.
3. When refueling, be sure to use a strainer for filtration. **DO NOT** top-off fuel. Wipe up any spilled fuel **immediately!**

## Before Starting

1. Read safety instructions at the beginning of manual.
2. Place pump as near to water as possible, on a firm flat, level surface.
3. To prime pump, remove fill cap (Figure 2) and fill pump casing with water. If the pump casing is not filled with water before starting, it will not begin pumping.

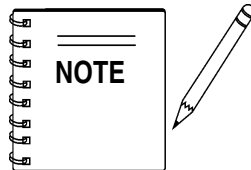

Suction and discharge hoses are available from Multiquip. Contact your nearest dealer for more information.

5. The discharge hose is usually a **collapsible** (thin-walled) hose, however if a thin-walled discharge hose is not available, a rigid suction hose can be substituted in its place.
6. Make sure the **suction strainer** (Figure 2) is clean and securely attached to the water end of the suction hose. The strainer is designed to protect the pump by preventing large objects from being pulled into the pump.

## CAUTION :

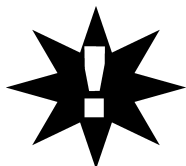

Pump casing **must** be filled with water before using pump. Otherwise pump will not be able to begin pumping.

## WARNING :



**DO NOT** open **fill cap** if pump is **hot!** Water inside may be under pressure.

4. Check for **leaks** between pump and engine. If water is leaking between the pump and engine housing, the seal inside the pump may be worn or damaged. Continued operation of the pump is not recommended. Further usage of the pump under these conditions may cause severe water damage to engine.

## CAUTION :

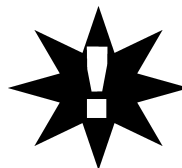

The strainer should be positioned so it will remain completely **under water**. Running the pump with the strainer above water for long periods can damage the pump.

## CAUTION :

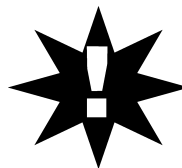

**DO NOT** pump flammable fluids, corrosive chemicals or fluids containing toxic substances. These fluids can create potentially dangerous health and environmental hazards. Contact local authorities for assistance.

## Hoses and Clamps

1. Check that all hoses are **securely** attached to the pump. Make certain suction hose (Figure 2) does not have any air leakage. Tighten hose clamps and couplings as required.
2. It is recommended that 2 clamps be used when securing the suction hose to the inlet side (suction) of the pump.
3. Remember suction hoses must be **rigid** enough not to collapse when the pump is in operation.
4. Check that the **discharge** hose (Figure 2) is not restricted. Place hose so that it lays as straight as it is possible on the ground. Remove any twists or sharp bends from hose which may block the flow of water.

## CAUTION :

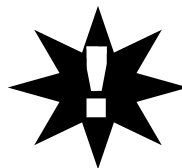

This pump uses a water-cooled **mechanical seal** to prevent water from seeping into the engine. The passage of water through the pump casing lubricates the seal and prevents it from overheating. **NEVER!** operate the pump without water in the casing as this will cause damage to the mechanical seal.



## CAUTION :

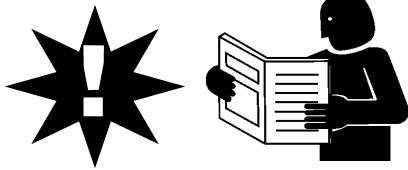

**DO NOT** attempt to operate the pump until the Safety, General Information and Inspection sections of this manual have been **read and thoroughly understood**.

This section is intended to assist the operator with the **initial start-up** of the trash pump. It is extremely important that this section be read carefully before attempting to use the pump in the field.

### Starting the Engine (*HONDA* engine)

1. Place the engine **fuel valve lever** (Figure 6) to the "ON" position.

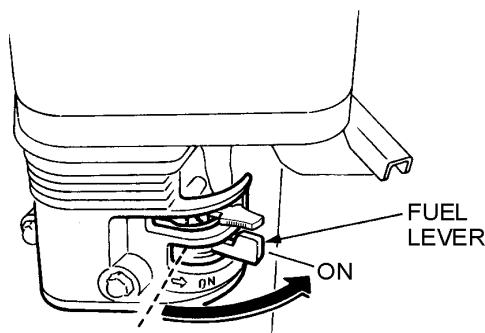

Figure 6. Engine Fuel Valve Lever (ON Position)

2. Move the **throttle lever** (Figure 7) away from the slow position, about 1/3 of the way toward the fast position.

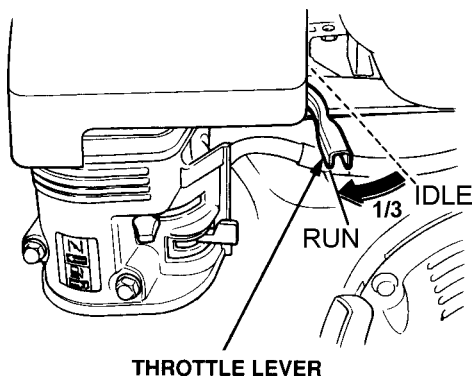

Figure 7. Throttle Lever (1/3 Start Position)

3. Place the **choke lever** (Figure 8) in the "OPEN" position if starting a **cold** engine.

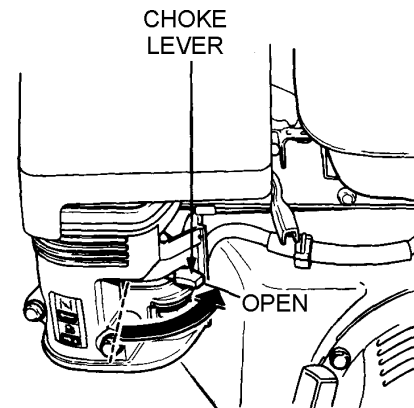

Figure 8. Engine Choke Lever (Open)

4. Place the **choke lever** (Figure 9) in the "CLOSED" position if starting a **warm engine** or the **temperature is warm**.

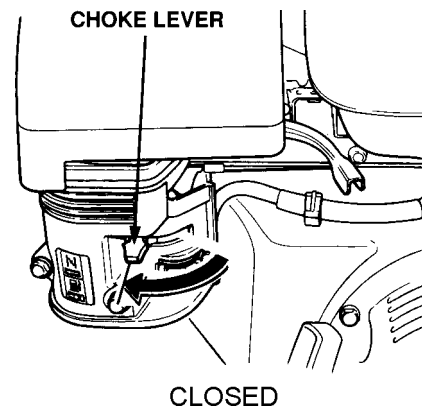

Figure 9. Engine Choke Lever (Closed)

5. Place the **engine ON/OFF switch** (Figure 10) in the "ON" position.

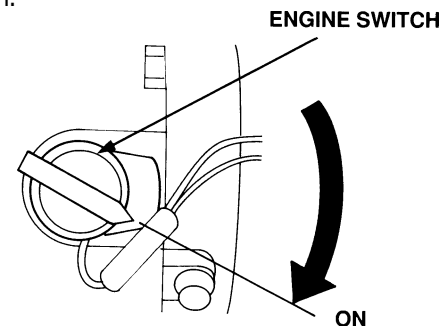

Figure 10. Engine ON/OFF Switch (ON Position)

## QP40TH — INITIAL START-UP (ENGINE)

6. Grasp the starter grip (Figure 11) and slowly pull it out. The resistance becomes the hardest at a certain position, corresponding to the compression point. Pull the starter grip briskly and smoothly for starting.

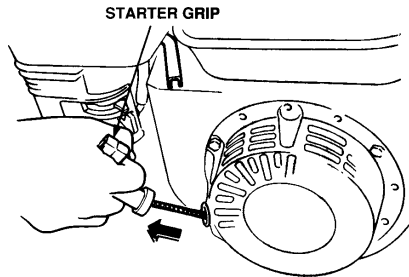

Figure 11. Starter Grip

7. If the engine has started, slowly return the choke lever (Figure 12) to the **CLOSED** position. If the engine has not started repeat steps 1 through 6.

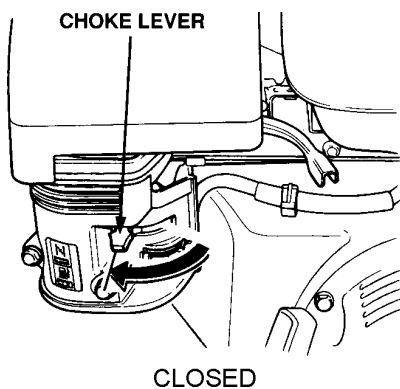

Figure 12. Choke Lever (Closed)

8. Before the pump is placed into operation, run the engine for several minutes. Check for fuel leaks, and noises that would associate with a loose component.
9. To begin pumping, place the throttle lever (Figure 13) in the "RUN" position.

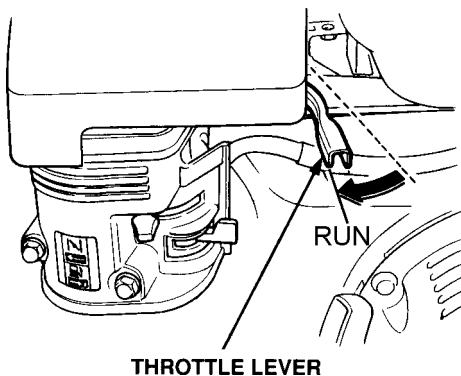
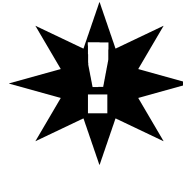

Figure 23. Throttle Lever (Run)

### CAUTION :



**ALWAYS** run engine at **full speed** while pumping.

### Stopping The Engine

#### Normal Shutdown

1. Move the throttle lever to the **IDLE** position (Figure 27) and run the engine for three minutes at low speed.

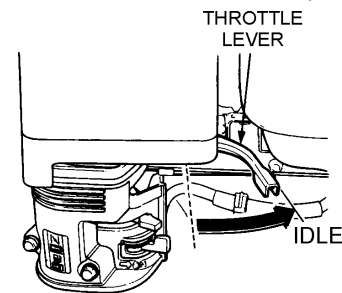

Figure 14. Throttle Lever (Idle)

2. After the engine **cools**, turn the engine ON/OFF switch to the "OFF" position (Figure 15).

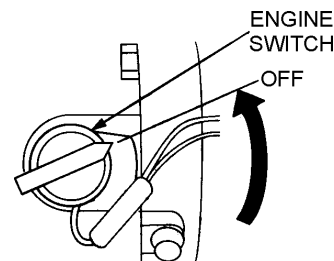

Figure 15. Engine ON/OFF Switch (OFF)

3. Place the **fuel shut-off lever** (Figure 16) in the **OFF** position.

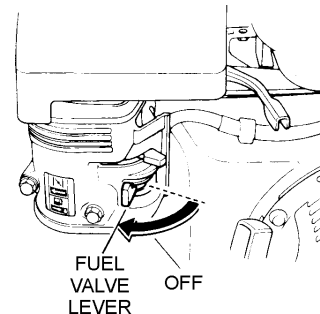

Figure 16. Fuel Valve Lever (OFF)

#### Emergency Showdown

1. Move the throttle lever quickly to the **IDLE** position, and place the engine ON/OFF switch in the **OFF** position.



## Pump Vacuum Test

### CAUTION :

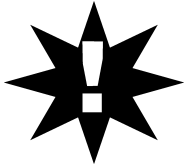

**DO NOT** attempt to start the engine unless the pump has previously been **primed** with water. Severe pump damage will occur if pump has not been primed.

To perform the pump vacuum test do the following:

1. Remove the pump fill cap, and fill the pump with water.
2. Start the engine as outlined in the initial start-up section, and wait for the pump to begin pumping.
3. As shown in Figure 17 (next page), place a water hose inside the discharge opening of the pump, and turn on the water. This flow of water into the discharge opening will **prevent** the pump from running dry.
4. Place the **Pump Vacuum Tester** (P/N 7000030) over the pump suction (inlet) opening (Figure 17) with the vacuum gauge facing upwards. It may be necessary to apply a small amount of water around the rubber seal of the vacuum tester to make a good suction fit.
5. Check and make sure that there are no air leaks between the vacuum tester and the inlet port on the pump. If air leaks are present reseal vacuum tester.
6. Run the pump for a few minutes while monitoring the vacuum gauge. If the gauge indicates a reading between -25 and -20 in. Hg. (inches of mercury) then it can be assumed that the pump is working correctly.

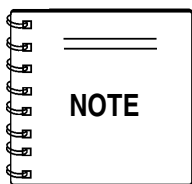

25 in. Hg (inches of mercury) translates into 25 feet of lift at **sea level**.

7. If the vacuum tester gauge indicates a reading **below** -20 in. Hg, it can then be assumed that the pump is not functioning correctly, and corrective action needs to be taken.
6. To test the **flapper valve**, shut down the engine. The vacuum tester should remain attached to the pump suction inlet port by vacuum. This indicates the pump's flapper valve is seating properly to hold water in the suction hose when the engine is stopped. This prevents backflow and allows for faster priming when the engine is restarted.

## Adjusting Impeller Clearance

1. If it is necessary to replace impeller or volute, be sure clearance between impeller and volute is adjusted correctly.
2. The impeller should be as close to the volute as possible without rubbing against it. Clearance is adjusted by adding or removing **shims** from behind the impeller.
3. Check clearance between impeller and insert by slowly pulling starter rope to turn impeller. Remove spark plug to make it easier to turn impeller.

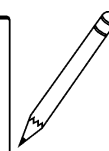
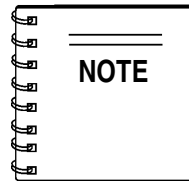

It is important not to remove too many shims or the clearance between the impeller and volute will become **too wide** and pump performance will be reduced. Remember as the impeller wear

down, additional shims may be required to maintain the clearance between the impeller and insert.

4. Check the impeller **every six months** for wear, and for clearance between the impeller face and the volute. Also check the shaft seal for wear, as well as the shaft sleeve.

## Pump Cleaning

After pumping water containing large amounts of dirt and debris, perform the following:

1. Remove the drain plug from the pump housing (Figure 1) and drain any water left in the pump.
2. Loosen the two locking hand knobs (turn counter-clockwise) and remove **clean-out cover**.
3. Clean and remove dirt, debris from pump casing. Inspect impeller and volute for wear. Replace any damaged or worn parts.

### CAUTION :

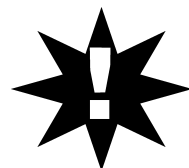

The impeller may develop **sharp edges**. Use extreme care when cleaning around the impeller to prevent being cut.

**CAUTION**

DO NOT RUN PUMP  
WITHOUT WATER.

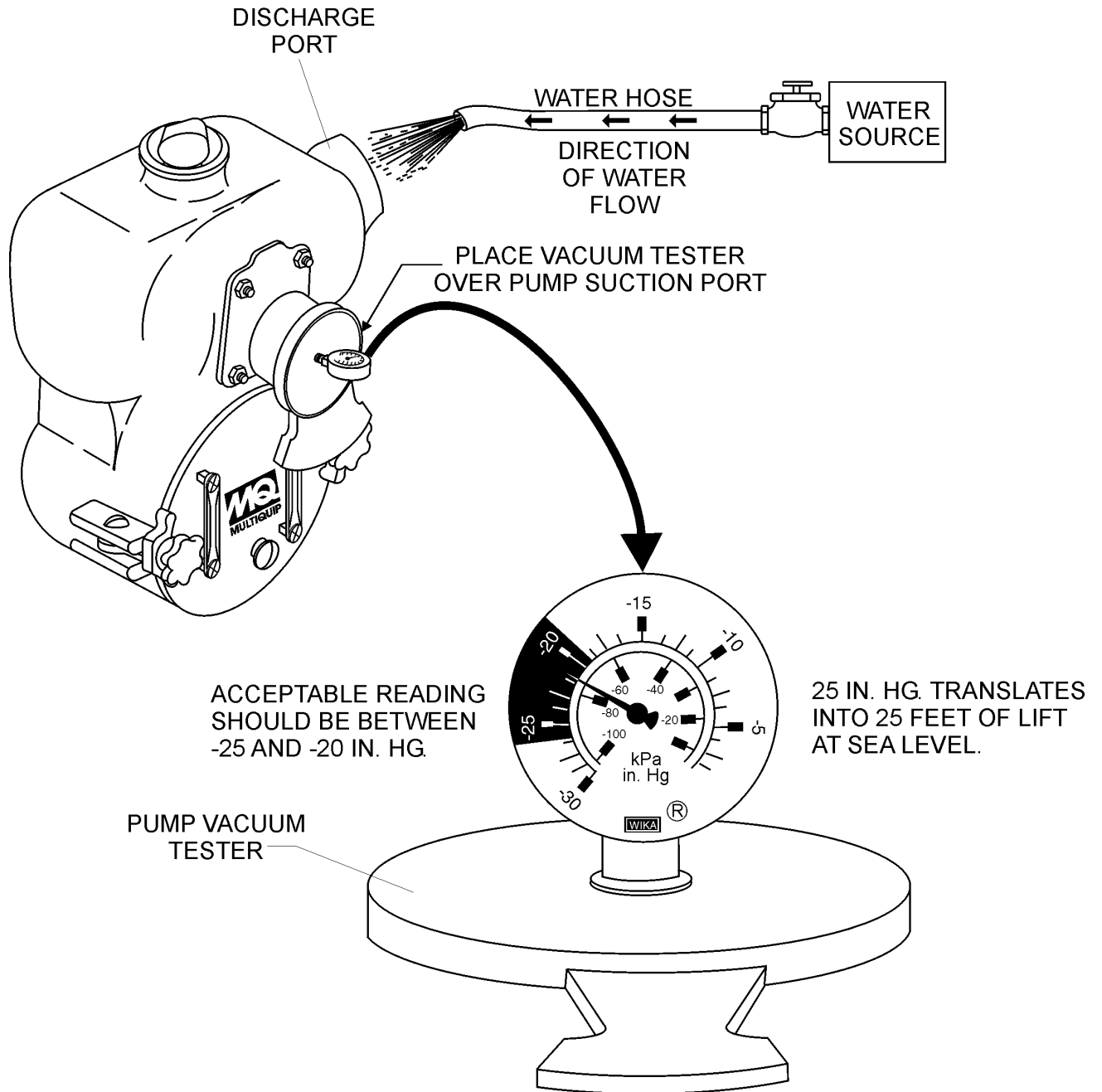

Figure 17. Pump Vacuum Tester

# QP40TH — MAINTENANCE (ENGINE)

## Engine Maintenance

Perform engine maintenance procedures as referenced by Table 4 below:

Table 4. Engine Maintenance Schedule							
DESCRIPTION (3)	OPERATION	BEFORE	FIRST MONTH OR 10 HRS.	EVERY 3 MONTHS OR 25 HRS.	EVERY 6 MONTHS OR 50 HRS.	EVERY YEAR OR 100 HRS.	EVERY 2 YEARS OR 200 HRS.
Engine Oil	CHECK	X					
	CHANGE		X				
Air Cleaner	CHECK	X					
	CHANGE			X (1)			
All Nuts & Bolts	Re-tighten If Necessary	X					
Spark Plug	CHECK-CLEAN				X		
	REPLACE						X
Cooling Fins	CHECK				X		
Spark Arrester	CLEAN					X	
Fuel Tank	CLEAN					X	
Fuel Filter	CHECK					X	
Idle Speed	CHECK-ADJUST					X (2)	
Valve Clearance	CHECK-ADJUST						X (2)
Fuel lines	CHECK	Every 2 years (replace if necessary) (2)					

(1) Service more frequently when used in **DUSTY** areas.

(2) These items should be serviced by your servic dealer, unless you have the proper tools and are mechanically proficient. Refer to the HONDA shop Manual for service procedures

(3) For commercial use, log hours of operation to determine proper maintenance intervals.

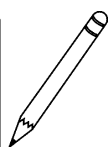
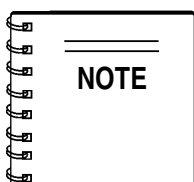

Reference manufacturer engine manual for specific servicing instructions.

## Maintenance

Perform the engine maintenance procedures as indicated below:

### DAILY

- Thoroughly remove dirt and oil from the engine and control area. Clean or replace the air cleaner elements as necessary. Check and retighten all fasteners as necessary. Check the spring box and bellows for oil leaks. Repair or replace as needed.

### WEEKLY

- Remove the fuel filter cap and clean the inside of the fuel tank.
- Remove or clean the filter at the bottom of the tank.
- Remove and clean the spark plug (Figure 18), then adjust the spark gap to 0.028 ~0.031 inch (0.6~0.7 mm). This unit has electronic ignition, which requires no adjustments.

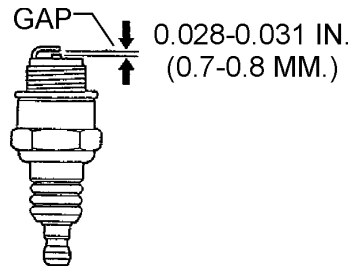

Figure 18. Spark Plug Gap

## ENGINE OIL

- Drain the engine oil when the oil is **warm** as shown in Figure 19.
- Remove the oil drain bolt and sealing washer and allow the oil to drain into a suitable container.
- Replace engine oil with recommended type oil as listed in Table 3. Engine oil capacity is 1.16 quarts (1.1 liters). **DO NOT** overfill.
- Install drain bolt with sealing washer and tighten securely.

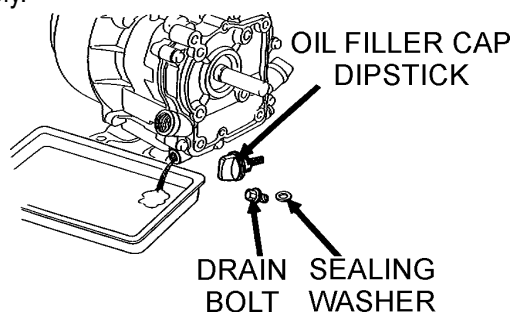
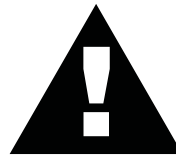

Figure 33. Engine Oil (Draining)

## DANGER :



**DO NOT** use gasoline as a cleaning solvent, because that would create a risk of fire or explosion.

## ENGINE AIR CLEANER

- Remove the air cleaner cover and foam filter element as shown in Figure 20.
- Tap the paper filter element (Figure 20) several times on a hard surface to remove dirt, or blow compressed air [not exceeding 30 psi (207 kPa, 2.1 kgf/cm<sup>2</sup>)] through the filter element from the air cleaner case side. **NEVER** brush off dirt. Brushing will force dirt into the fibers. Replace the paper filter element if it is excessively dirty.
- Clean foam element in warm, soapy water or nonflammable solvent. Rinse and dry thoroughly. Dip the element in clean engine oil and completely squeeze out the excess oil from the element before installing.

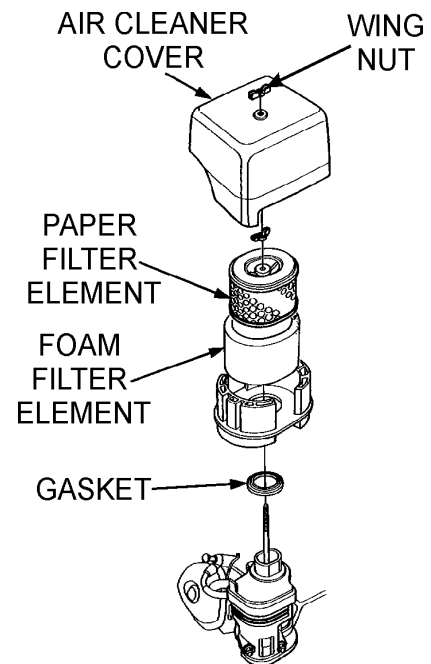

Figure 20. Engine Air Cleaner

## Pump Storage

For storage of the pump for over 30 days, the following is required:

- Drain the fuel tank completely.
- Run the engine until the fuel in the injection system is completely consumed.
- Completely drain used oil from the engine crankcase and fill with fresh clean oil, then follow the procedures described in the engine manual for engine storage.
- Remove the drain plug from the pump and drain out any water from left in the housing.
- Remove the pump cover and clean inside of pump housing. Coat inside of pump housing with a light film of oil to reduce corrosion. A spray can of oil works well for this application.
- Cover suction and discharge ports with duct tape to prevent any foreign matter from falling into pump.
- Cover pump and engine with plastic covering or equivalent and store in a clean, dry place.
- To protect the water cooled-seals, place one-half pint of lubricating oil (new or used) through the discharge opening on the pump and crank the engine several times. This will prevent excessive corrosion and also keep the mechanical seal lubricated.



# QP40TH — TROUBLESHOOTING (ENGINE)

## TABLE 5. ENGINE TROUBLESHOOTING

SYMPTOM	POSSIBLE PROBLEM	SOLUTION
<b>Difficult to start</b>		
Fuel is available but spark plug will not ignite. (Power available at high tension cable).	Ignition plug being bridge?	Check ignition system.
	Carbon deposit at ignition?	Clean or replace ignition.
	Short circuit due to defective insulators?	Replace insulators.
	Improper spark gap?	Set spark plug gap to the correct gap.
Fuel is available but spark plug will not ignite. (Power <b>NOT</b> available at high tension cable).	Short circuit at stop switch?	Check stop switch circuit. Replace stop switch if defective.
	Ignition coil defective?	Replace ignition coil.
Fuel is available and spark plug ignites (compression <b>normal</b> ).	Muffler clogged with carbon deposits?	Clean or replace muffler.
	Mixed fuel quality is inadequate?	Check fuel to oil mixture.
	Fuel in use inadequate (water, dust)?	Flush fuel sytem and replace with fresh fuel.
	Air Cleaner clogged?	Clean or replace air cleaner.
Fuel is available and spark plug ignites (compression <b>low</b> ).	Defective cylinder head gasket?	Tighten cylinder head bolts or replace head gasket.
	Cylinder worn?	Replace cylinder.
	Spark plug loose?	Tighen spark plug.
<b>Operation not satisfactory</b>		
Not enough power available (compression normal, no miss-firing).	Air cleaner clogged?	
	Air in fuel line?	Bleed (remove air) from fuel line.
	Fuel level in carbureator float chamber improper?	Adjust carbureator float
	Carbon deposits in cylinder?	Clean or replace cylinder
Not enough power available (compression normal, miss-firing).	Ignition coil defective?	Flush fuel sytem and replace with fresh fuel.
	Ignition plug often shorts?	Replace ignition wires, clean ignition.
	Fuel in use inadequate (water, dust)?	Flush fuel sytem and replace with fresh fuel.
Engine overheats.	Excessive carbon depostion in combustion chamber?	Clean or replace crankcase.
	Exhaust or muffler clogged with carbon.	Clean or replace muffler.
	Spark plug heat value incorrect?	Replace spark plug with correct type spark plug.

# QP40TH — TROUBLESHOOTING (ENGINE/PUMP)

## TABLE 5. ENGINE TROUBLESHOOTING (Continued)

SYMPTOM	POSSIBLE PROBLEM	SOLUTION
<b>Operation not satisfactory</b>		
Rotational speed fluctuates.	Governor adjustment improper?	Adjust governor to correct lever.
	Governor spring defective?	Clean or replace ignition.
	Fuel flow erratic?	Check fuel line.
	Air taken in through suction line?	Check suction line.
Recoil starter not working properly.	Dust in rotating part?	Clean recoil starter assembly.
	Spring spring failure?	Replace sprial spring.

## TABLE 6 PUMP TROUBLESHOOTING

SYMPTOM	POSSIBLE PROBLEM	SOLUTION
Pump does not take on water.	Not enough priming water in the housing?	Add water.
	Engine speed too low?	Increase throttle.
	Strainer plugged?	Clean strainer.
	Suction hose damaged?	Replace or repair hose, and clamps
	Air leak at suction port?	Check that fittings are tight and properly sealed.
	Pump is located too high above water line?	Move pump closer to water.
	Debris collecting in pump housing?	Clean pump housing.
	Too much distance between impeller and volute.	Adjust clearance by adding shims or replace impeller. Min. .006" - Max. .020"
Pump takes in water, little or no discharge.	Engine speed too low?	Increase throttle speed.
	Suction strainer partially plugged?	Clean strainer.
	Impeller/Volute worn?	Adjust clearance by adding shims or replace impeller/volute
Suction hose leaks at inlet.	Fittings/clamps are not sealed properly?	Tighten, replace or add clamp. (Keep extra seals on pump)
	Hose diameter is too large?	Use smaller diameter hose or replace hose.
Discharge does not stay on coupling.	Pressure too high?	Check pressure, add additional clamp.
	Hose kinked or end blocked?	Check hose.
Impeller does not turn: pump is hard to start.	Impeller jammed or blocked?	Open pump cover and clean dirt and debris from inside housing.
	Impeller and volute binding?	Adjust clearance by removing shim from behind impeller.
	Defective engine?	See Hatz Diesel Engine Owner's Manual.

# EXPLANATION OF CODE IN REMARKS COLUMN

How to read the marks and remarks used in this parts book.

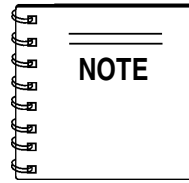

*The contents of this parts catalog are subject to change without notice.*

## Items Found In the “Remarks” Column

Serial Numbers-Where indicated, this indicates a serial number range (inclusive) where a particular part is used.

Model Number-Where indicated, this shows that the corresponding part is utilized only with this specific model number or model number variant.

## Items Found In the “Items Number” Column

All parts with same symbol in the number column, \*, #, +, %, or ■, belong to the same assembly or kit.

Note: If more than one of the same reference number is listed, the last one listed indicates newest (or latest) part available.

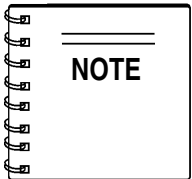

If more than one of the same reference number is listed, the last one listed indicates newest (or latest) part available.

**QP40TH 1 TO 5 UNITS WITH HONDA  
GX340K1QA2 ENGINE*****1 to 5 Units***

<b>Qty.</b>	<b>P/N</b>	<b>Description</b>
1	0482200240	O-RING (MECHANICAL SEAL SLEEVE)
2	0801123530	MECHANICAL SEAL
1	0811883034	MECHANICAL SEAL SLEEVE
3	0852834525	ADJUST LINER
3	0852854525	ADJUST LINER
1	1418040030	IMPELLER
2	0489312300	O-RING (CASING, VOLUTE)
1	0489352400	O-RING (DRAIN COVER)
1	1412000130	VOLUTE CASING
1	1401350350	CHECK VALVE
4	0631211100	DRAIN CAP
3	0480350300	O-RING, DRAIN CAP
4	1247000190	DRAIN COVER SET KNOB
1	0742214100	STEEL STRAINER
5	17210ZE3505	ELEMENT AIR CLEANER
5	17218ZE3505	FILTER OUTER
5	9807956846	SPARK PLUG (HONDA)
1	17620ZH7023	CAP, FUEL TANK (HONDA)
2	17672ZE2W01	FUEL, FILTER

# QP40TH — PUMP ASSY.

PUMP ASSY.

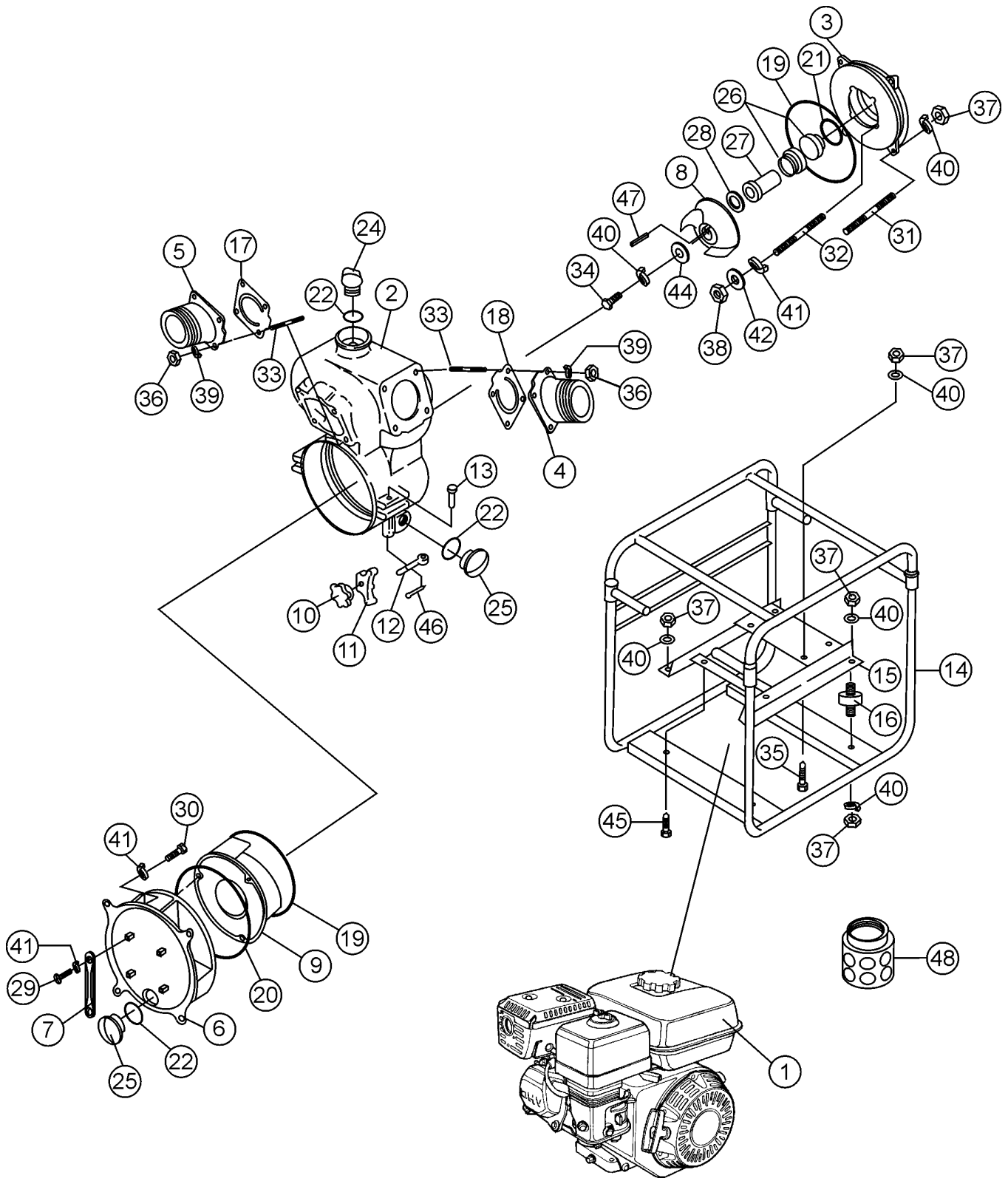

PUMP ASSY.

<u>NO.</u>	<u>PART NO.</u>	<u>PART NAME</u>	<u>QTY.</u>	<u>REMARKS</u>
1	GX340K1QA2	ENGINE, HONDA GX340K1QA2	1	
2	1412060010	CASING	1	
3	1418060021	CASING COVER	1	
4	1414000090	DELIVERY COVER NPT4"	1	
5	1414000090	SUCTION COVER NPT4"	1	
6	1268100170	DRAIN COVER	1	
7	1247100250	DRAIN COVER HANDLE	2	
8	1418040030	IMPELLER	1	
9	1412000130	VOLUTE CASING	1	
10	1247000190	DRAIN COVER SET HANDLE	2	
11	1247000200	DRAIN COVER PUSH PLATE	2	
12	1247200270	HINGE BOLT M12 x 90	2	
13	1247220280	HINGE PIN DIA 12 x 65	2	
14	1414214010	BASE	1	
15	1437214020	ENGINE BASE	1	
16	0723302546	CUSHION RUBBER	4	
17	1401350350	CHECK VALVE	1	
18	1401330360	DELIVERY COVER PACKING	1	
19	0489312300	O-RING (VOLUTE CASING) DIA 3.1 x 228	2	
20	0489352400	O-RING (DRAIN COVER) DIA 3.5 x 240	1	
21	0482200240	O-RING (MECHANICAL SEAL SLEEVE) S24	1	
22	0480350300	O-RING (FLOODING-DRAIN CAP) P30	3	
24	0631211100	FLOODING CAP PF1"	1	
25	0631211100	DRAIN CAP PF1"	2	
26	0801123530	MECHANICAL SEAL DIA 30	1	
27	0811883034	MECHANICAL SEAL SLEEVE	1	
28	0852834525	ADJUST LINER DIA 45 x 25.4 10.3	1	
28	0852854525	ADJUST LINER DIA 45 x 25.4 10.5	1	
29	0141050825	SCREW (DRAIN COVER HANDLE) M8 x 25	4	
30	0141090825	SCREW (VOLUTE CASING) M8 x 25	2	

# QP40TH — PUMP ASSY.

PUMP ASSY.

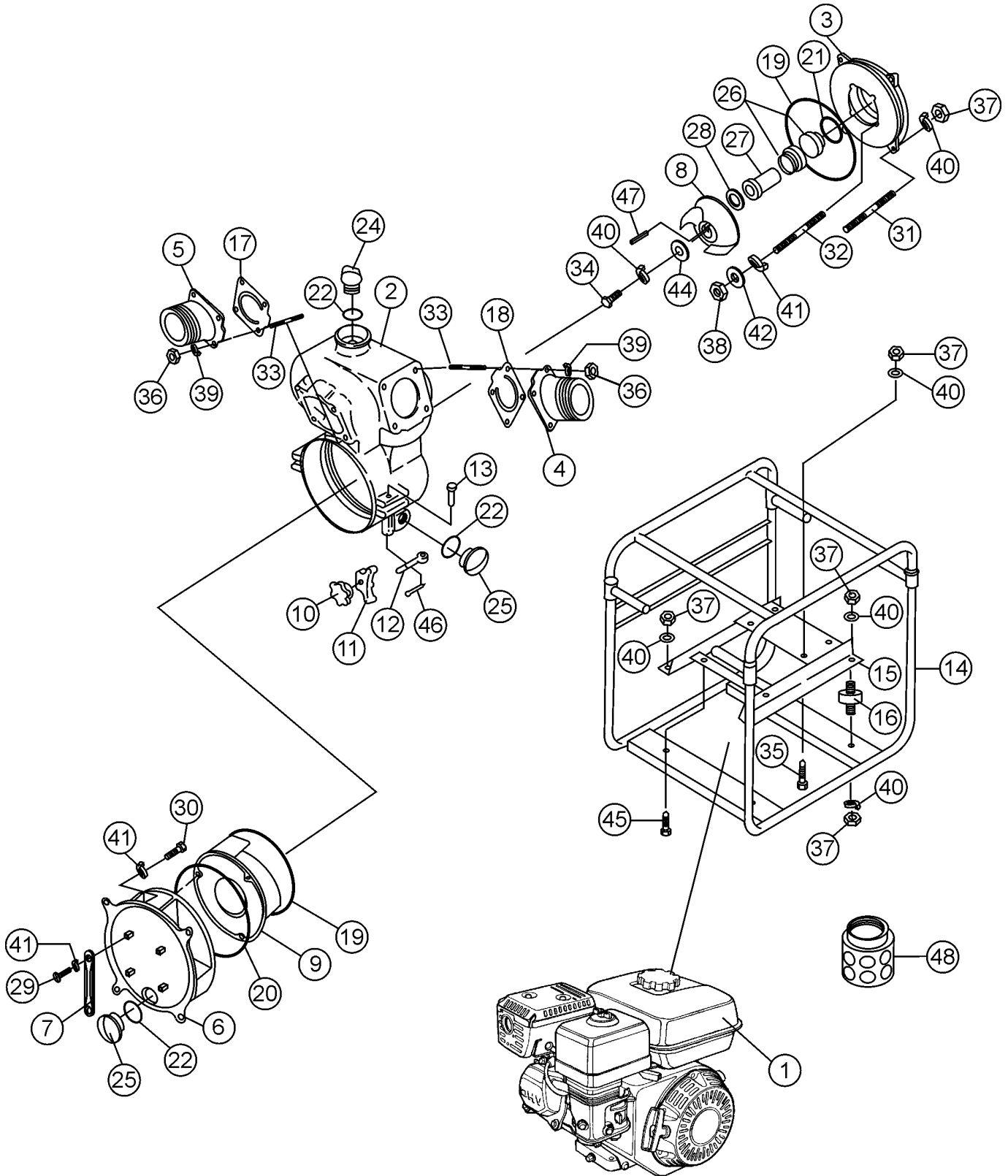



## PUMP ASSY.

<u>NO.</u>	<u>PART NO.</u>	<u>PART NAME</u>	<u>QTY.</u>	<u>REMARKS</u>
31	0151151025	STUD BOLT (CASING) M10 x 35 x 10 x 15	4	
32	0151140536	STUD BOLT (CASING CVR) 5/16" x 52 x 15 x 15	4	
33	0151151230	STUD BOLT (DELIVERY/SUCTION COVER) M12 x 45 x 15 x 20	8	
34	0191150625	BOLT (IMPELLER) 3/8-24 UNF x25	1	
35	0105051045	BOLT (ENGINE) M10 x 25	4	
36	0205450120	NUT (DELIVERY/SUCTION COVER) M12	8	
37	0205450100	NUT (CUSHION RUBBER, CASING, ENGINE, PUMP M10	18	
38	0205450055	NUT, 5/16"	4	
39	0451250120	SPRING WASHER M12	8	
40	0451250100	SPRING WASHER M10	19	
41	0458220080	SPRING WASHER M8	10	
42	0401450080	WASHER M8	4	
43	0401450100	WASHER M10	4	
44	1412201240	IMPELLER WASHER DIA 38 x 11 x 6T	1	
45	0105051035	BOLT (PUMP) M10 x 35	2	
46	0641400430	SPLIT PIN DIA 4 x 30	2	
47	0520040425	KEY 6.32 x 25.4	1	
48	0742214100	STRAINER NPT4"	1	

# HONDA GX340K1QA2 — AIR CLEANER ASSY.

AIR CLEANER ASSY.

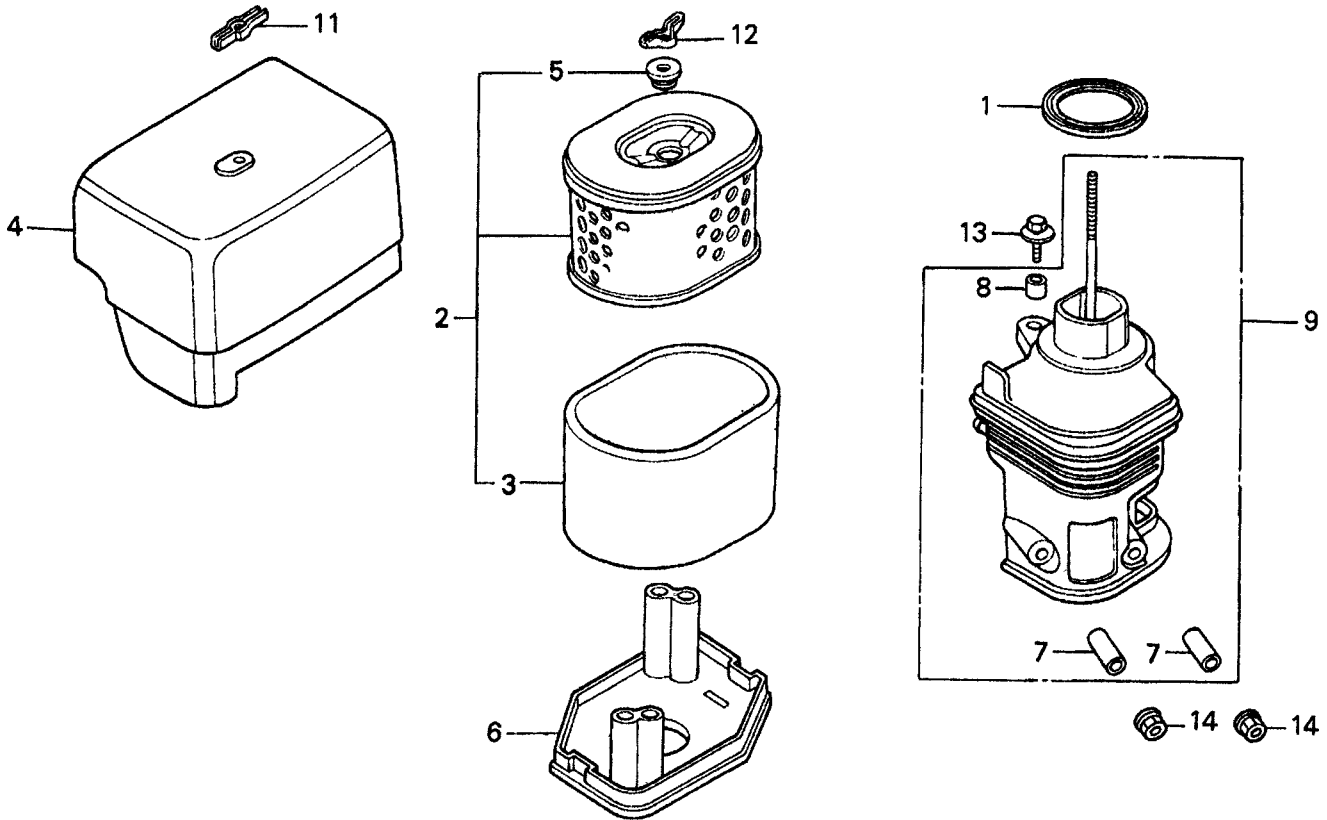

# HONDA GX340K1QA2 — AIR CLEANER ASSY.

AIR CLEANER ASSY.

<u>NO.</u>	<u>PART NO.</u>	<u>PART NAME</u>	<u>QTY.</u>	<u>REMARKS</u>
1	16271ZE2000	GASKET, ELBOW	1	
2	17210ZE3505	ELEMENT, AIR CLEANER	1	
3	17218ZE3505	FILTER, OUTER	1	
4	17231ZE3W00	COVER, AIR CLEANER	1	
5	17232891000	GROMMET, AIR CLEANER	1	
6	17235ZH9N00	NOSE, MUFFLER	1	
7 *	17238ZE2310	COLLAR, AIR CLEANER	2	
8 *	17239ZE1000	COLLAR B, AIR CLEANER	1	
9	17410ZH9N00	ELBOW, AIR CLEANER .....	1	INCLUDES ITEMS W/*
11	90203ZA0800	WINGNUT, 6MM	1	
12	90325044000	WINGNUT, TOOL BOX SETTING	1	
13	934040602008	BOLT- WASHER, 6X20	1	
14	9405006000	NUT, FLANGE (6MM)	2	

# HONDA GX340K1QA2 — CAMSHAFT ASSY.

CAMSHAFT ASSY.

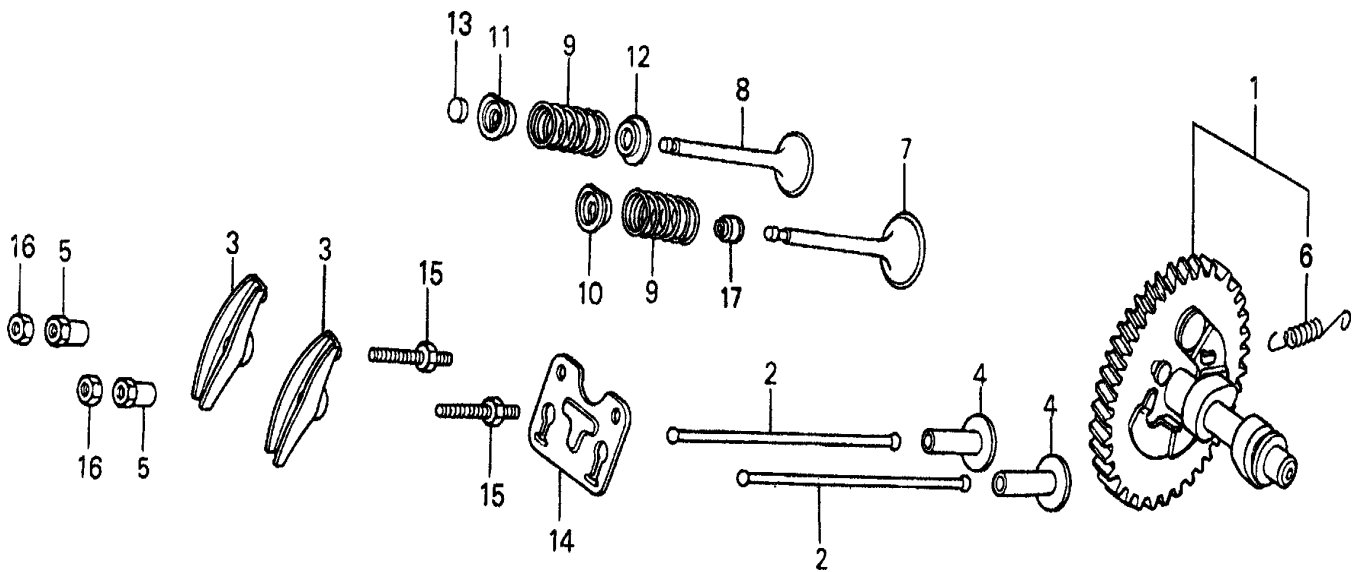

# HONDA GX340K1QA2 — CAMSHAFT ASSY.

## CAMSHAFT ASSY.

<u>NO.</u>	<u>PART NO.</u>	<u>PART NAME</u>	<u>QTY.</u>	<u>REMARKS</u>
1	14100ZE3305	CAMSHAFT ASSEMBLY .....	1 .....	INCLUDES ITEMS W/*
2	14410ZE3013	ROD, PUSH	2	
3	14431ZE2010	ARM, VALVE ROCKER	2	
4	14441ZE2000	LIFTER, VALVE	2	
5	14451ZE1013	PIVOT, ROCKER ARM	2	
6*	14568ZE1000	SPRING, WEIGHT RETURN	1	
7	14711ZE3000	VALVE, IN.	1	
8	14721ZE3000	VALVE, EX.	1	
9	14751ZE2003	SPRING, VALVE	2	
10	14771ZE2000	RETAINER, IN. VALVE SPRING	1	
11	14773ZE2000	RETAINER, EX. VALVE SPRING	1	
12	14775ZE2010	SEAT, VALVE SPRING	1	
13	14781ZE2000	ROTATOR, VALVE	1	
14	14791ZE2010	PLATE, PUSH ROD GUIDE	1	
15	90012ZE0010	BOLT, PIVOT (8MM)	2	
16	90206ZE1000	NUT, PIVOT ADJ.	2	
17	12209ZE8003	SEAL, VALVE STEM .....	1 .....	USE FROM ENGINE SN 3334264

# HONDA GX340K1QA2 — PISTON ASSY.

PISTON ASSY.

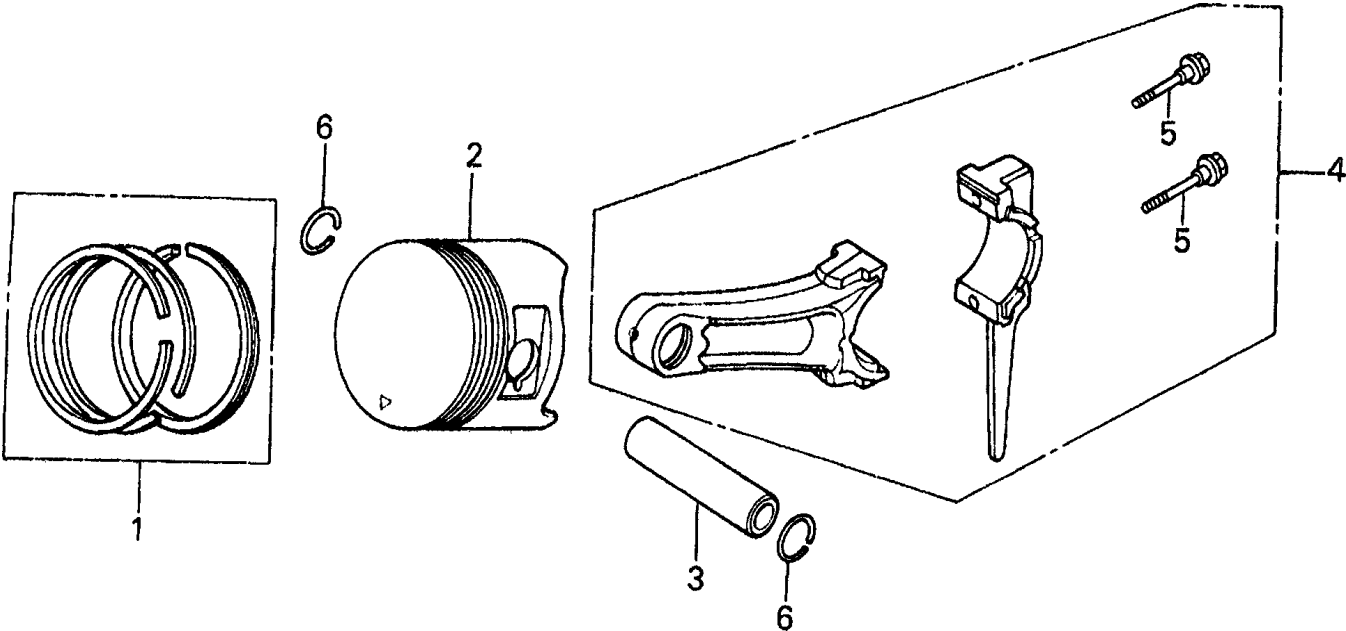

# HONDA GX340K1QA2 — PISTON ASSY.

## PISTON ASSY.

<u>NO.</u>	<u>PART NO.</u>	<u>PART NAME</u>	<u>QTY.</u>	<u>REMARKS</u>
1	13010ZE3003	RING SET, PISTON- STANDARD	1	
1	13011ZE3003	RING SET, PISTON- OS 0.25	1	
1	13012ZE3003	RING SET, PISTON- OS 0.50	1	
1	13013ZE3003	RING SET, PPISTON- 0.75	1	
2	13101ZE3W00	PISTON- STANDARD	1	
2	13102ZE3W00	PISTON- OS 0.25	1	
2	13103ZE3W00	PISTON- OS 0.50	1	
2	13104ZE3W00	PISTON- 0.75	1	
3	13111ZF6000	PIN, PISTON	1	
4	13200ZE3010	ROD ASSEMBLY, CONNECTING (STD.) .....	1	INCLUDES ITEMS W/*
4	13200ZE3315	ROD ASSEMBLY, CONNECTING- US 0.25 .....	1	INCLUDES ITEMS W/*
5*	90001ZE8000	BOLT, CONNECTING ROD	2	
6	90601ZE3000	CLIP, PISTON PIN 20MM	2	

# HONDA GX340K1QA2 — CRANKCASE COVER ASSY.

CRANKCASE COVER ASSY.

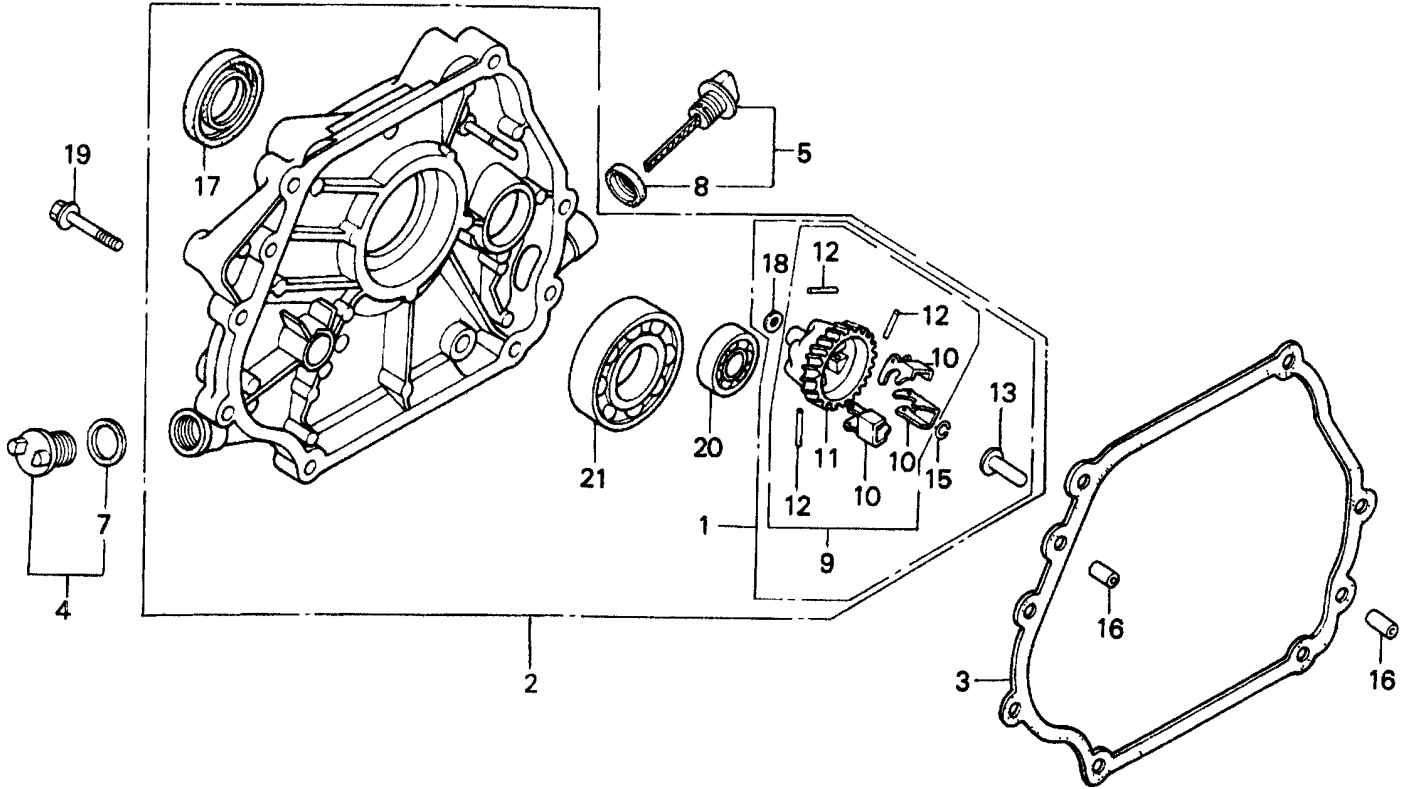



# HONDA GX340K1QA2 — CRANKCASE COVER ASSY.

## CRANKCASE COVER ASSY.

<u>NO.</u>	<u>PART NO.</u>	<u>PART NAME</u>	<u>QTY.</u>	<u>REMARKS</u>
1+	06165ZE3000	GOVERNOR KIT, .....	1 .....	INCLUDES ITEMS W/*
2	11300ZE3602	COVER ASSEMBLY, CRANKCASE Q- TYPE ...	1 .....	INCLUDES ITEMS W/+
3	11381ZE3801	GASKET, CASE COVER	1	
4	15600ZG4003	CAP ASSEMBLY, OIL FILLER .....	1 .....	INCLUDES ITEMS W/\$
5	15600735003	CAP ASSEMBLY, OIL FILLER .....	1 .....	INCLUDES ITEMS W/■
7\$	15625ZE1003	GASKET, OIL FILLER CAP	1	
8■	15625ZE1003	GASKET, OIL FILLER CAP	1	
9+	16510ZE3000	GOVERNOR ASSEMBLY .....	1 .....	INCLUDES ITEMS W/%
10*+%	16511ZE8000	WEIGHT, GOVERNOR	3	
11*+%	16512ZE3000	HOLDER, GOVERNOR WEIGHT	1	
12*+%	16513ZE2000	PIN, GOVERNOR WEIGHT	3	
13*+	16531ZE2000	SLIDER, GOVERNOR	1	
15*+	90602ZE1000	CLIP, GOVERNOR HOLDER	1	
16	90701HC4000	PIN, DOWEL 8X12	2	
17+	91201ZE3004	OIL SEAL 35X52X8	1	
18*+	9410106800	WASHER, PLAIN 6MM	1	
19	957010804000	BOLT, FLANGE 8X40	7	
20+	961006202000	BEARING, RADIAL BALL 6202	1	
21+	961006207000	BEARING, RADIAL BALL 6207	1	

# HONDA GX340K1QA2 — CRANKSHAFT ASSY.

CRANKSHAFT ASSY.

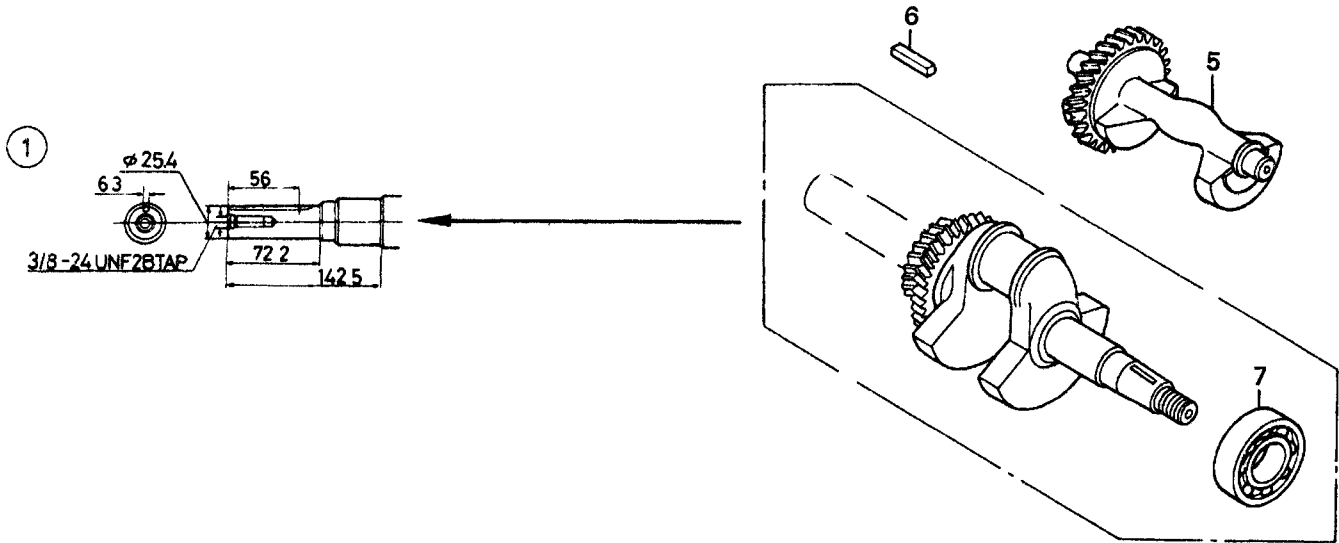

# HONDA GX340K1QA2 — CRANKSHAFT ASSY.

CRANKSHAFT ASSY.

<u>NO.</u>	<u>PART NO.</u>	<u>PART NAME</u>	<u>QTY.</u>	<u>REMARKS</u>
1	13310ZE3601	CRANKSHAFT Q- TYPE .....	1 .....	INCLUDES ITEMS W/*
5	13351ZE3010	WEIGHT, BALANCER	1	
6	90756ZE2600	KEY 6.3X6.3X43	1	
7	961006207000	BEARING, RADIAL BALL 6207	1	

# HONDA GX340K1QA2 — CYLINDER BARREL ASSY.

CYLINDER BARREL ASSY.

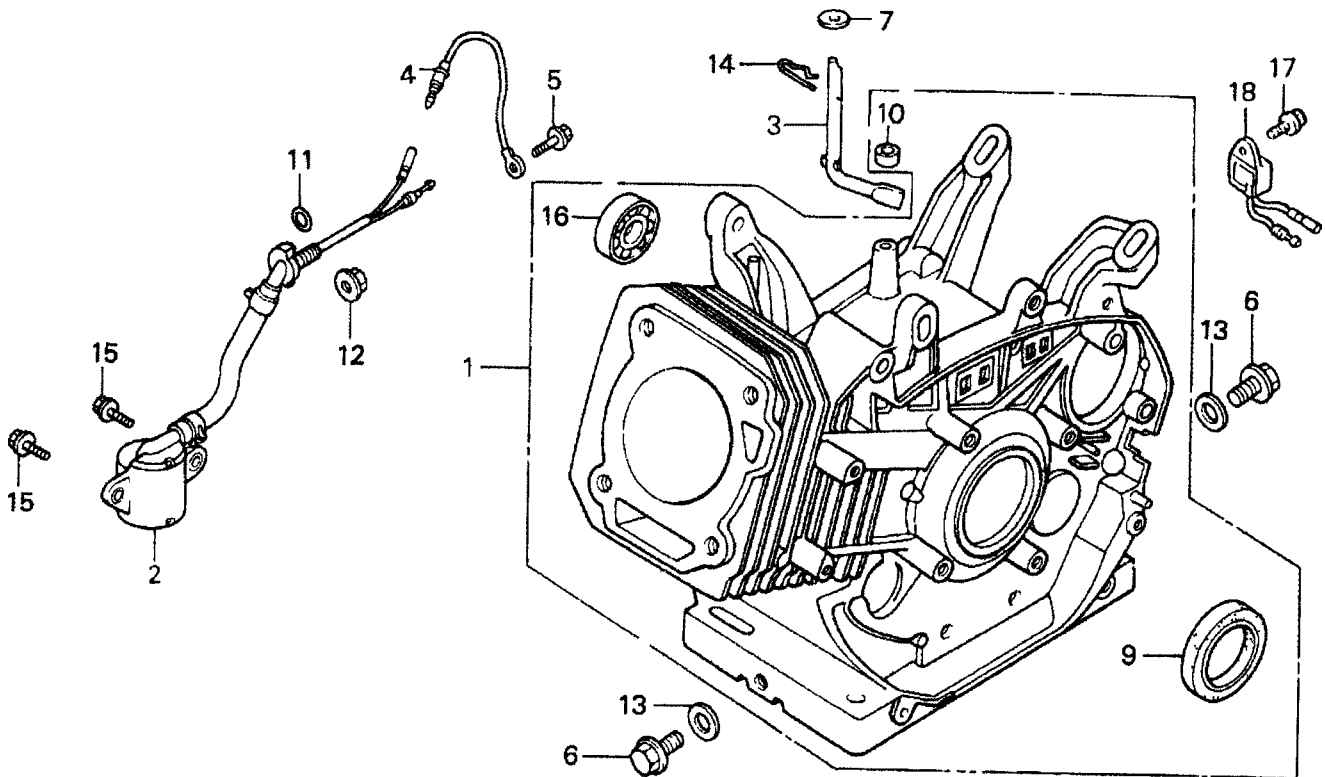

# HONDA GX340K1QA2 — CYLINDER BARREL ASSY.

## CYLINDER BARREL ASSY.

<u>NO.</u>	<u>PART NO.</u>	<u>PART NAME</u>	<u>QTY.</u>	<u>REMARKS</u>
1	12000ZE3816	CYLINDER ASSEMBLY .....	1 .....	INCLUDES ITEMS W/*
2	15510ZE2043	SWITCH ASSEMBLY, OIL LEVEL .....	1 .....	USE FROM ENGINE SN 2639738 TO 2786139
3	16541ZE3010	SHAFT, GOVERNOR ARM	1	
4	32197ZE2003	SUB- HARNESS .....	1 .....	USE UP TO ENGINE SN 2639737
5	90013883000	BOLT, FLANGE 6X12 (CT200) .....	1 .....	USE UP TO ENGINE SN 2639737
6	90131896650	BOLT, DRAIN PLUG	2	
7	90446KE1000	WASHER 8.2X17X0.8	1	
9*	91201ZE3004	OIL SEAL 35X52X8	1	
10*	91201ZE9003	OIL SEAL 8X14X5	1	
11	91353671003	O- RING 13.5X1.5	1	
12	9405010000	NUT, FLANGE 10MM	1	
13	9410912000	WASHER, DRAIN PLUG 12MM	2	
14	9425110000	PIN, LOCK 10MM	1	
15	957010601200	BOLT, FLANGE 6X12	2	
16*	961006202000	BEARING, RADIAL BALL 6202	1	
17	90013883000	BOLT, FLANGE 6X12 (CT200)	1	
18	34150ZH7003	ALERT UNIT, OIL	1	

# HONDA GX340K1QA2 — CYLINDER HEAD ASSY.

CYLINDER HEAD ASSY.

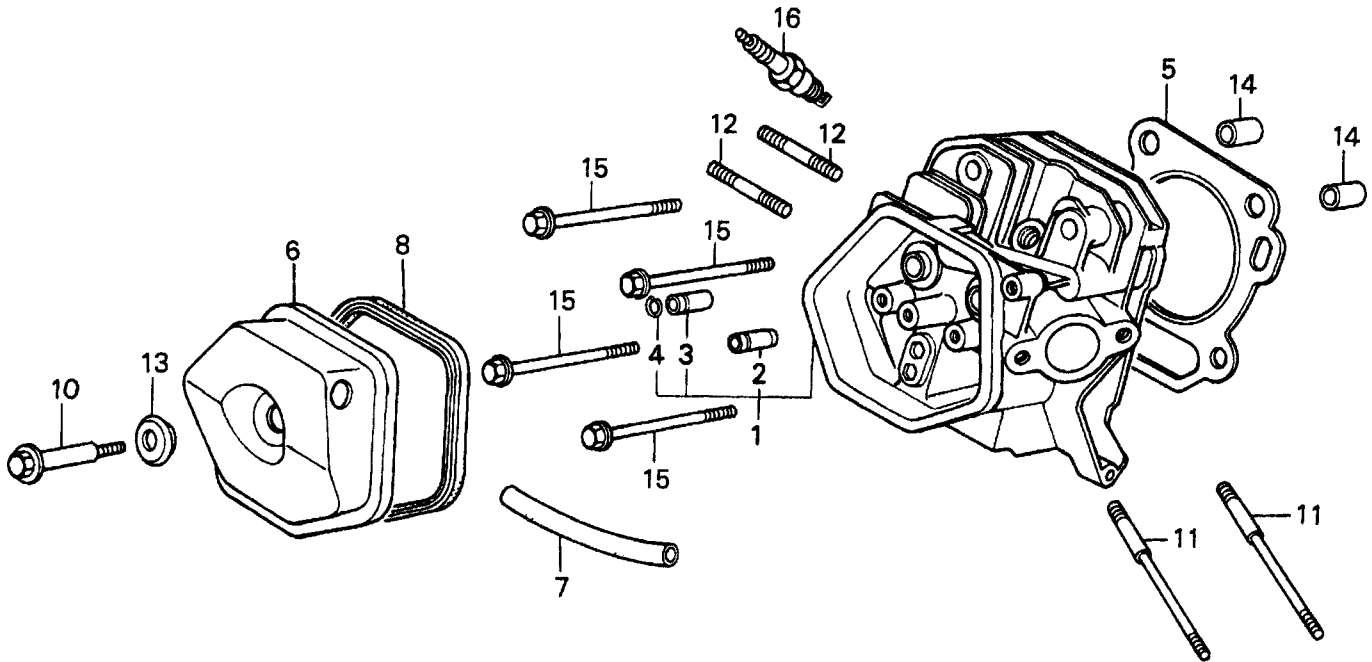

# HONDA GX340K1QA2 — CYLINDER HEAD ASSY.

## CYLINDER HEAD ASSY.

<u>NO.</u>	<u>PART NO.</u>	<u>PART NAME</u>	<u>QTY.</u>	<u>REMARKS</u>
1	12200ZF6W01	CYLINDER HEAD .....	1 .....	INCLUDES ITEMS W/*
2*	12204ZE2306	GUIDE, EX. VALVE OS (OPTIONAL)	1	
3*	12205ZE2305	GUIDE, EX. VALVE OS (OPTIONAL)	1	
4*	12216ZE2300	CLIP, VALVE GUIDE	1	
5	12251ZE3W00	GASKET, CYLINDER HEAD	1	
6	12310ZE3791	COVER, HEAD	1	
7	12315ZE3840	TUBE, BREATHER	1	
8	12391ZE2020	GASKET, CYLINDER HEAD COVER	1	
10	90014ZE2000	BOLT, HEAD COVER	1	
11	90042ZE8000	BOLT, STUD 8X131.5	2	
12	90047ZE2000	BOLT, STUD 8X47 .....	2 .....	USE UP TO ENGINE SN 3033461
12	92900080320E	BOLT 2, STUD 8X32 .....	2 .....	USE FROM ENGINE SN 3033462
13	90441ZE2010	WASHER, HEAD COVER	1	
14	9430112200	PIN A, DOWEL 12X20	2	
15	957011008000	BOLT, FLANGE 10X80	4	
16	9807956846	SPARK PLUG, BPR6ES (NGK)	1	

# HONDA GX340K1QA2 — FAN COVER ASSY.

FAN COVER ASSY.

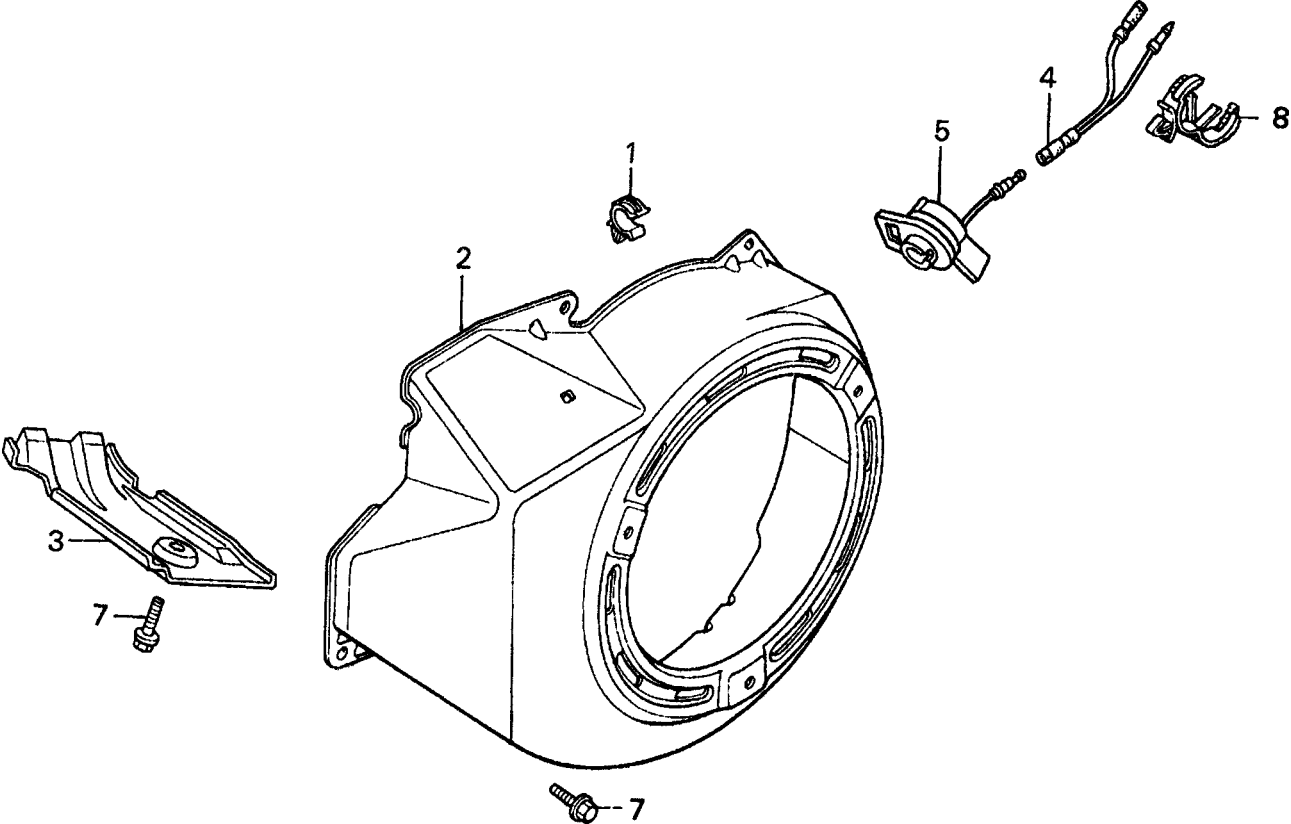



# HONDA GX340K1QA2 — FAN COVER ASSY.

FAN COVER ASSY.

<u>NO.</u>	<u>PART NO.</u>	<u>PART NAME</u>	<u>QTY.</u>	<u>REMARKS</u>
1	16731ZE2003	CLIP, TUBE	1	
2	19610ZE3010ZA	COVER, FAN *R8* (BRIGHT RED)	1	
3	19631ZE3W00	SHROUD	1	
4	32197ZH8003	SUB- HARNESS .....	1	USE UP TO ENGINE SN 2639737
5	36100ZE1015	SWITCH ASSEMBLY, ENGINE STOP .....	1	USE UP TO ENGINE SN 2639737
5	36100ZH7003	SWITCH ASSEMBLY, ENGINE STOP .....	1	USE FROM ENGINE SN 2639738
7	90013883000	BOLT, FLANGE 6X12 (CT200)	6	
8	90684ZA0601	CLIP, WIRE HARNESS	1	

# HONDA GX340K1QA2 — FLYWHEEL ASSY.

FLYWHEEL ASSY.

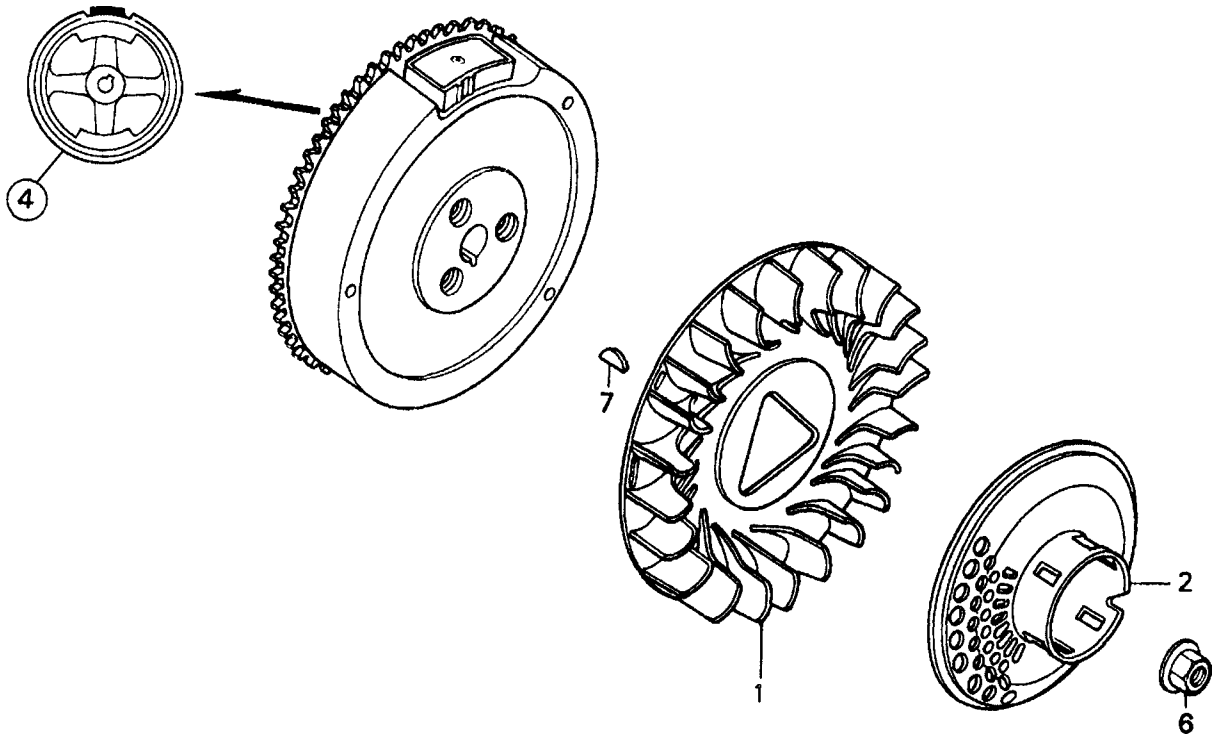

# HONDA GX340K1QA2 — FLYWHEEL ASSY.

## FLYWHEEL ASSY.

<u>NO.</u>	<u>PART NO.</u>	<u>PART NAME</u>	<u>QTY.</u>	<u>REMARKS</u>
1	19511ZE3000	FAN, COOLING	1	
2	28450ZE3W11	PULLEY, STARTER (SCREEN GRID)	1	
4	31100ZE3701	FLYWHEEL	1	
6	90201ZE3V00	NUT, SPECIAL 16MM (1) .....	1 .....	USE FROM ENGINE SN 2536523
6	90201ZE3790	NUT, SPECIAL 16MM .....	1 .....	USE UP TO ENGINE SN 2536522
7	90741ZE2000	KEY, SPECIAL WOODRUFF 25X18	1	

# HONDA GX340K1QA2 — FUEL TANK ASSY.

FUEL TANK ASSY.

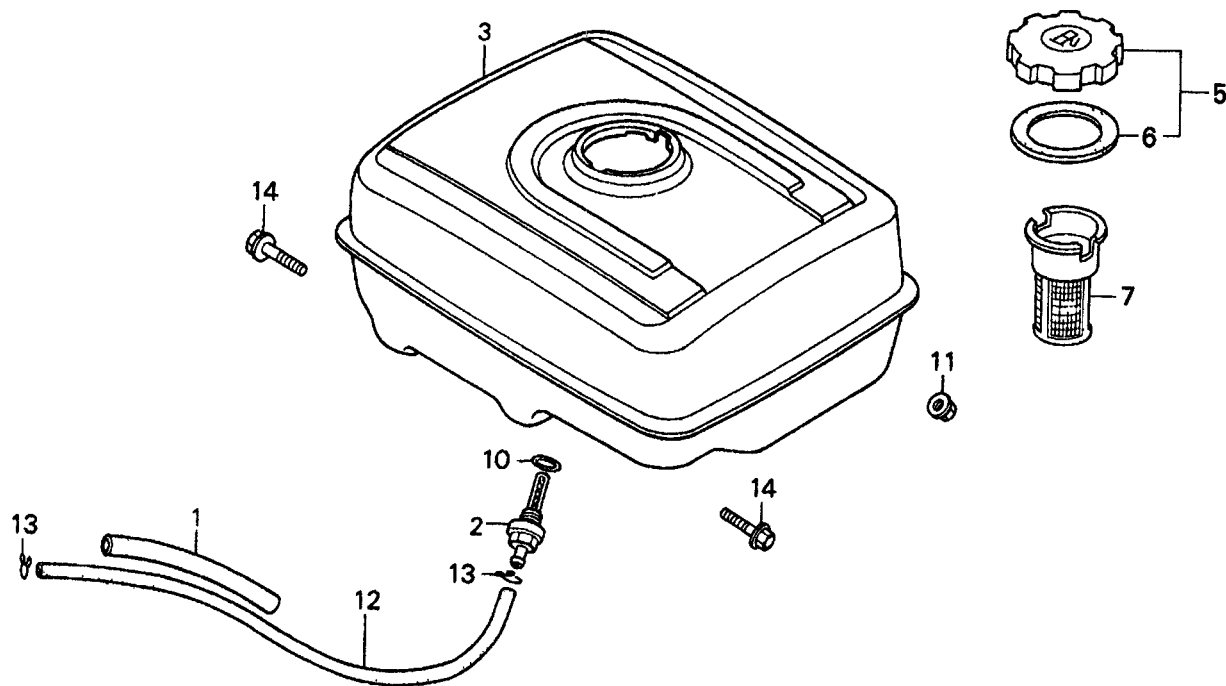

# HONDA GX340K1QA2 — FUEL TANK ASSY.

## FUEL TANK ASSY.

<u>NO.</u>	<u>PART NO.</u>	<u>PART NAME</u>	<u>QTY.</u>	<u>REMARKS</u>
1	16854ZH8000	RUBBER, SUPPORTER 107MM	1	
2	16955ZE1000	JOINT, FUEL TANK	1	
3	17510ZE3010ZA	TANK, FUEL *NH31* (MCKINLEY WHITE)	1	
3	17510ZE3010ZD	TANK FUEL *T34* (SIMPSON BLUE)	1	
5	17620ZH7023	CAP, FUEL FILLER .....	1	INCLUDES ITEMS W/*
6*	17631ZH7003	GASKET, FUEL FILLER CAP	1	
7	17672ZE2W01	FILTER, FUEL	1	
10	91353671003	O- RING 13.5X1.5 (ARA)	1	
11	9405008000	NUT, FLANGE 8MM	2	
12	950014500360M	BULK HOSE, FUEL (4.5X3000) (4.5X235)	1	
13	9500202080	CLIP, TUBE B8	2	
14	957010802500	BOLT, FLANGE 8X25	2	

# HONDA GX340K1QA2 — IGNITION COIL ASSY.

IGNITION COIL ASSY.

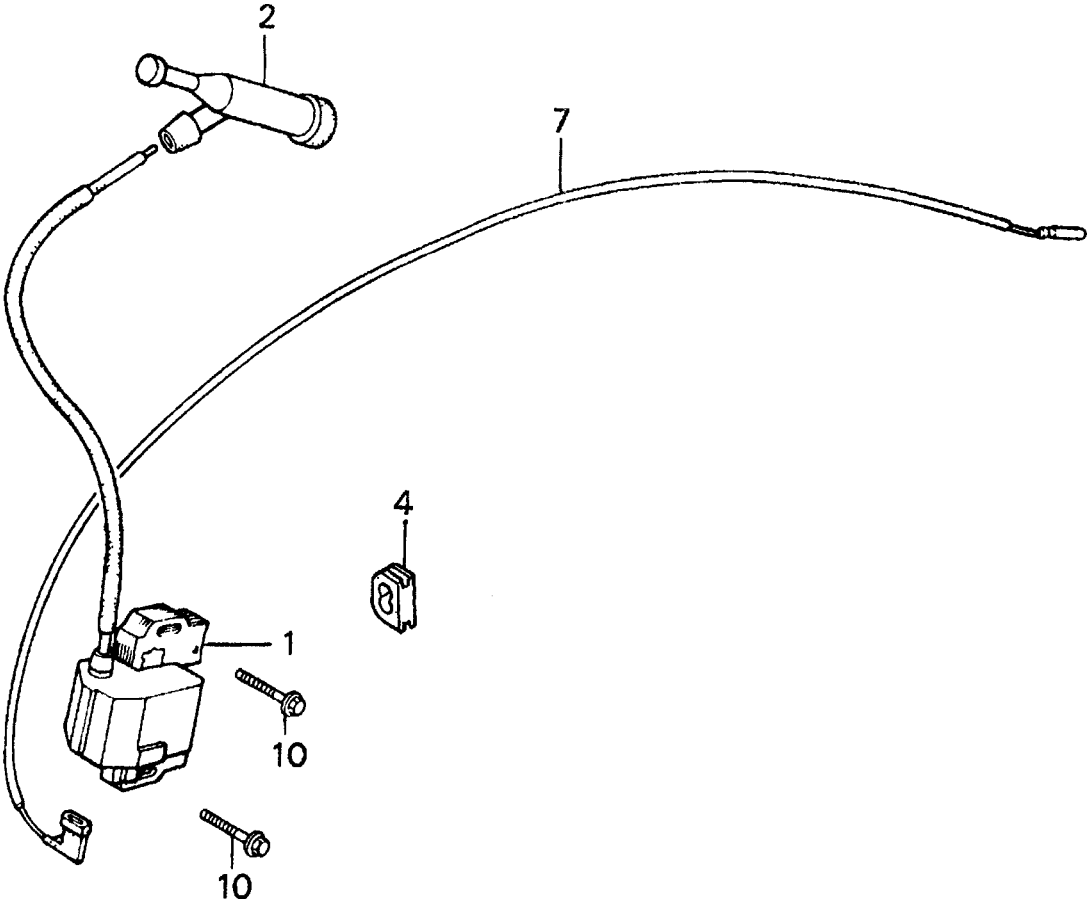

# HONDA GX340K1QA2 — IGNITION COIL ASSY.

## IGNITION COIL ASSY.

<u>NO.</u>	<u>PART NO.</u>	<u>PART NAME</u>	<u>QTY.</u>	<u>REMARKS</u>
1	30500ZE2023	COIL ASSEMBLY, IGNITION	1	
2	30700ZE1013	CAP ASSEMBLY, NOISE SUPPRESSOR	1	
4	31512ZE2000	GROMMET, WIRE	1	
7	36101ZE2701	WIRE, STOP SWITCH 430MM	1	
10	90015883000	BOLT, FLANGE 6X28	2	

# HONDA GX340K1QA2 — CARBURETOR ASSY.

CARBURETOR ASSY.

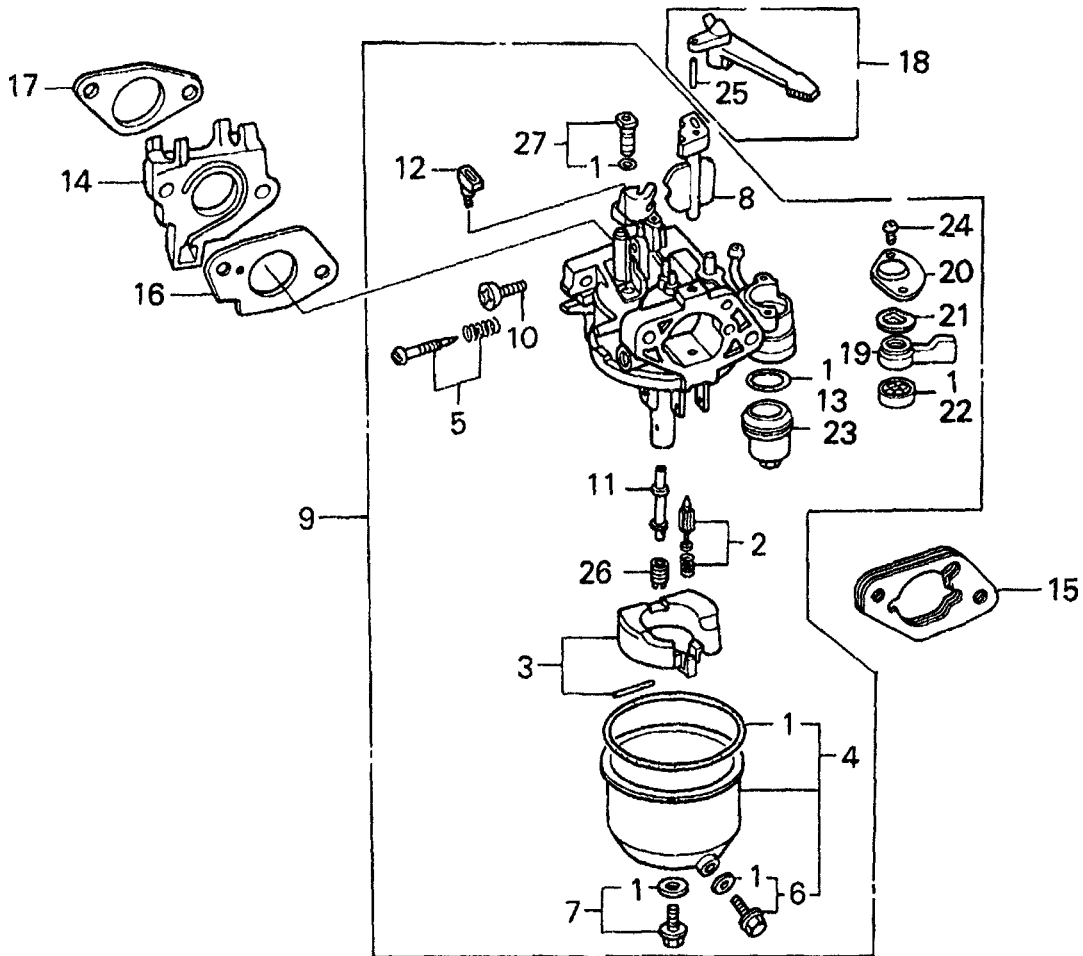



# HONDA GX340K1QA2 — CARBURETOR ASSY.

## CARBURETOR ASSY.

<u>NO.</u>	<u>PART NO.</u>	<u>PART NAME</u>	<u>QTY.</u>	<u>REMARKS</u>
1*%	16010ZE2812	GASKET SET	1	
2*	16011ZA0931	VALVE SET, FLOAT	1	
3*	16013ZA0931	FLOAT SET	1	
4*	16015ZE2005	CHAMBER SET, FLOAT .....	1 .....	INCLUDES ITEMS W/% USE UP TO ENGINE SN BE80B A
4*	16015ZE8005	CHAMBER SET, FLOAT .....	1 .....	INCLUDES ITEMS W/% USE FROM ENGINE SN BE80B B
5*	16016ZH7W01	SCREW SET	1	
6*%	16024ZE1811	SCREW SET, DRAIN	1	
7*	16028ZE0005	SCREW SET B	1	
8*	16044ZE3811	CHOKE SET	1	
9	16100ZE3V00	CARBURETOR ASSEMBLY, BE85B A .....	1 .....	INCLUDES ITEMS W/* USE UP TO ENGINE SN 2519695
9	16100ZE3V01	CARBURETOR ASSEMBLY, BE80B B .....	1 .....	USE FROM ENGINE SN 2519696
9	16100ZE3V01	CARBURETOR ASSEMBLY, BE80B B .....	1 .....	USE UP TO ENGINE SN 2519695
10*	16124ZE0005	SCREW, THROTTLE STOP	1	
11*	16166ZE3W50	NOZZLE, MAIN	1	
12*	16172ZE3W10	COLLAR, SET	1	
13	16173001004	GASKET, FUEL STRAINER CUP	1	
14	16211ZE3000	INSULATOR, CARBURETOR	1	
15	16220ZA0702	SPACER, CARBURETOR	1	
16	16221ZE3800	GASKET, CARBURETOR	1	
17	16223ZE3800	GASKET, INSULATOR	1	
18	16610ZE1000	LEVER, CHOKE (STANDARD)	1	INCLUDES ITEMS W/+
19	16953ZE1812	LEVER, VALVE .....	1 .....	USE FROM ENGINE SN BE80B B
20	16954ZE1812	PLATE, LEVER SETTING .....	1 .....	USE FROM ENGINE SN BE80B B
21*	16956ZE1811	SPRING, VALVE LEVER	1	
22*	16957ZE1812	GASKET, VALVE	1	
23*	16967ZE0811	CUP, FUEL STRAINER	1	
24*	93500030060H	SCREW, PAN (3X6) .....	2 .....	USE FROM ENGINE SN BE80B B
25+	9430520122	PIN, SPRING (2X12)	1	
26	99101ZH80880	JET, MAIN #88 (OPTIONAL)	1	
26	99101ZH80900	JET, MAIN #90 (OPTIONAL)	1	
26	99101ZH80920	JET, MAIN #92 (OPTIONAL)	1	
27	99204ZE00350	JET SET, PILOT #35	1	

# HONDA GX340K1QA2 — CARBURETOR ASSY.

CARBURETOR ASSY.

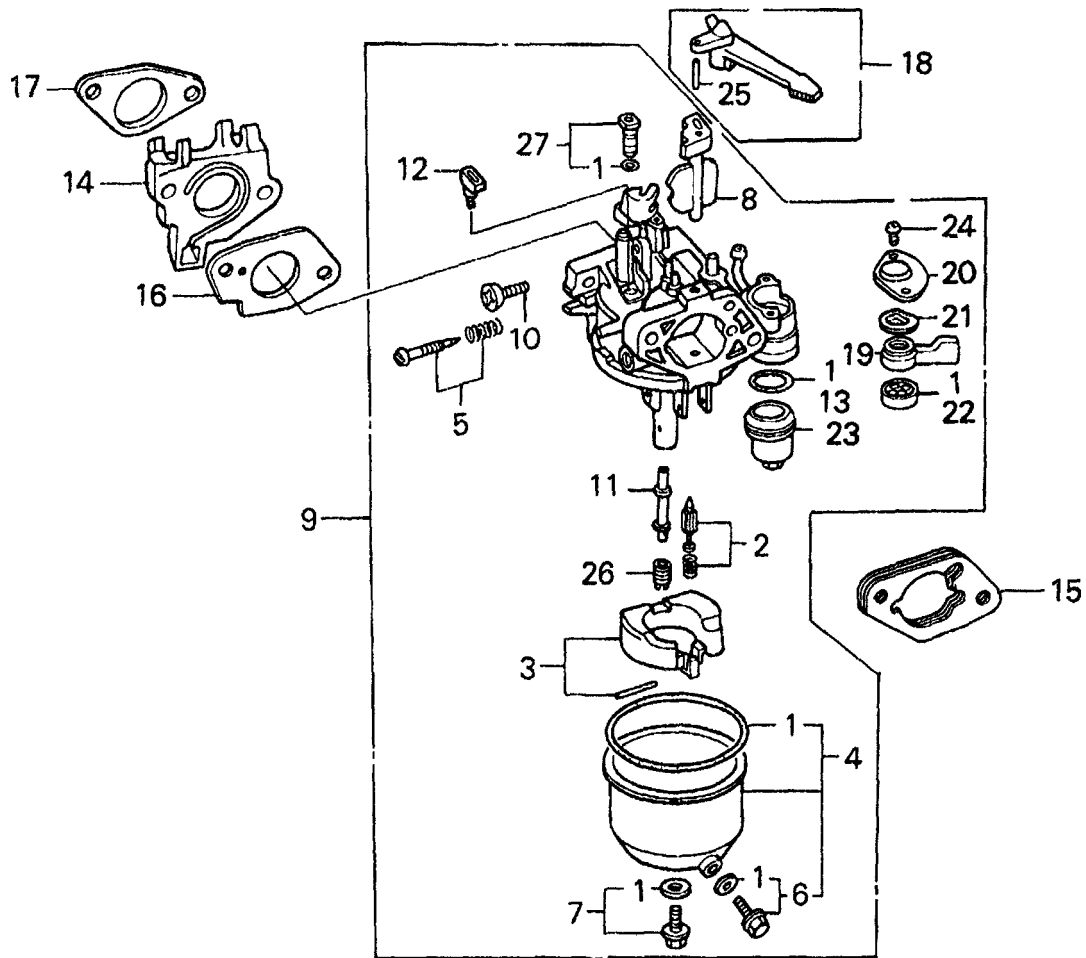

# HONDA GX340K1QA2 — CARBURETOR ASSY.

## CARBURETOR ASSY.

<u>NO.</u>	<u>PART NO.</u>	<u>PART NAME</u>	<u>QTY.</u>	<u>REMARKS</u>
21*	16956ZE1811	SPRING, VALVE LEVER	1	
22*	16957ZE1812	GASKET, VALVE	1	
23*	16967ZE0811	CUP, FUEL STRAINER	1	
24*	93500030060H	SCREW, PAN (3X6) .....	2	..... USE FROM ENGINE SN BE80B B
25+	9430520122	PIN, SPRING (2X12)	1	
26	99101ZH80880	JET, MAIN #88 (OPTIONAL)	1	
26	99101ZH80900	JET, MAIN #90 (OPTIONAL)	1	
26	99101ZH80920	JET, MAIN #92 (OPTIONAL)	1	
27	99204ZE00350	JET SET, PILOT #35	1	

# HONDA GX340K1QA2 — MUFFLER ASSY.

MUFFLER ASSY.

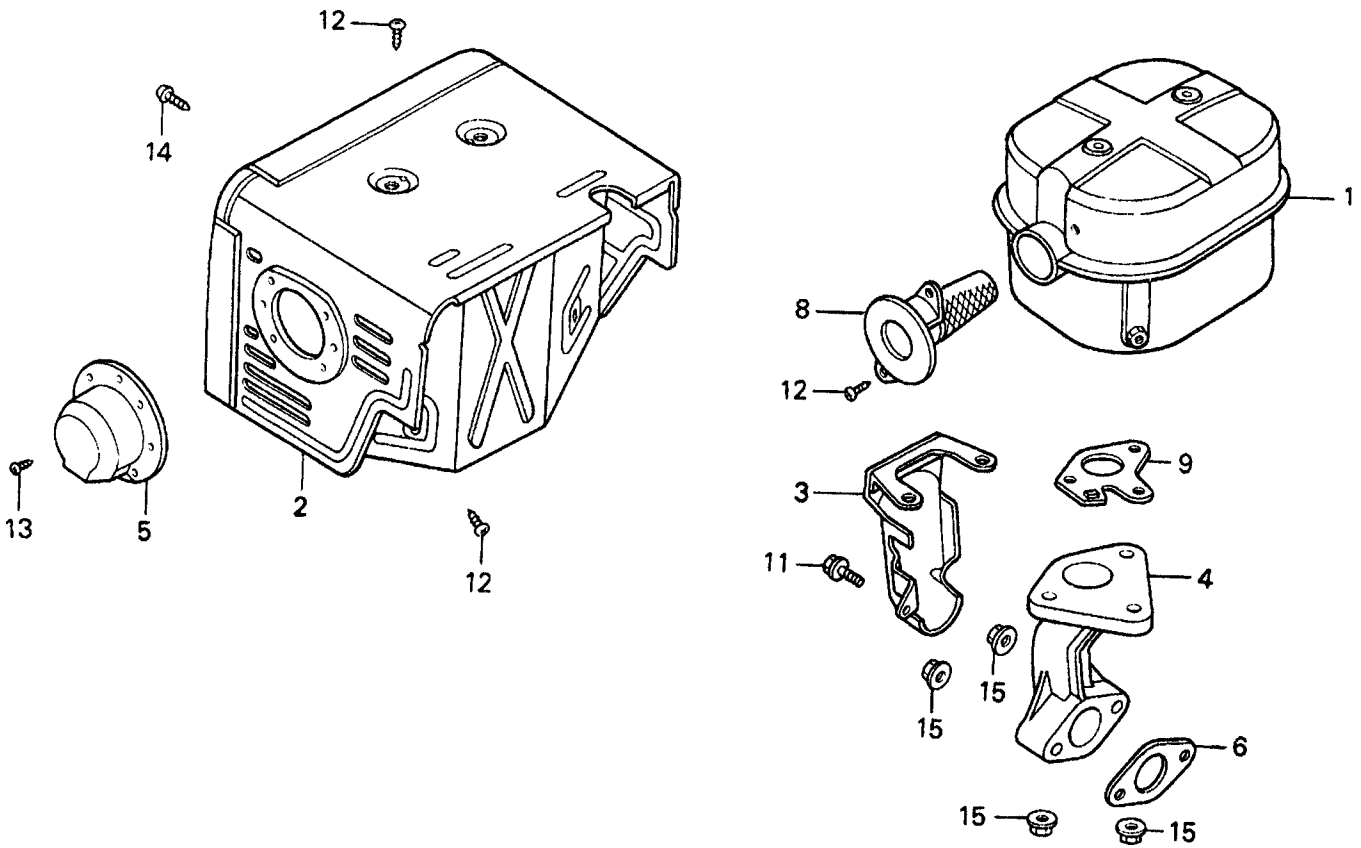

# HONDA GX340K1QA2 — MUFFLER ASSY.

## MUFFLER ASSY.

<u>NO.</u>	<u>PART NO.</u>	<u>PART NAME</u>	<u>QTY.</u>	<u>REMARKS</u>
1	18310ZE3W00	MUFFLER	1	
2	18320ZE3W01	PROTECTOR, MUFFLER	1	
3	18323ZE3W40	PROTECTOR, EX. PIPE	1	
4	18330ZE2W00	PIPE, EX.	1	
5	18331ZE3810	CAP, MUFFLER	1	
6	18333ZF6W01	GASKET, EX. PIPE	1	
6	18333ZK6Y00	GASKET, EX. PIPE (WACKER)	1	
8	18355ZE3010	ARRESTER, SPARK	1	
9	18381ZE2W10	GASKET, MUFFLER (ARRESTER)	1	
11	90013883000	BOLT, FLANGE 6X12 (CT200)	1	
12	90050ZE1000	SCREW, TAPPING 5X8	6	
13	90055ZE1000	SCREW, TAPPING 4X6	3	
14	93500060060B	SCREW, PAN 6X6	1	
15	9405008000	NUT, FLANGE 8MM	5	

# HONDA GX340K1QA2 — RECOIL STARTER ASSY.

RECOIL STARTER ASSY.

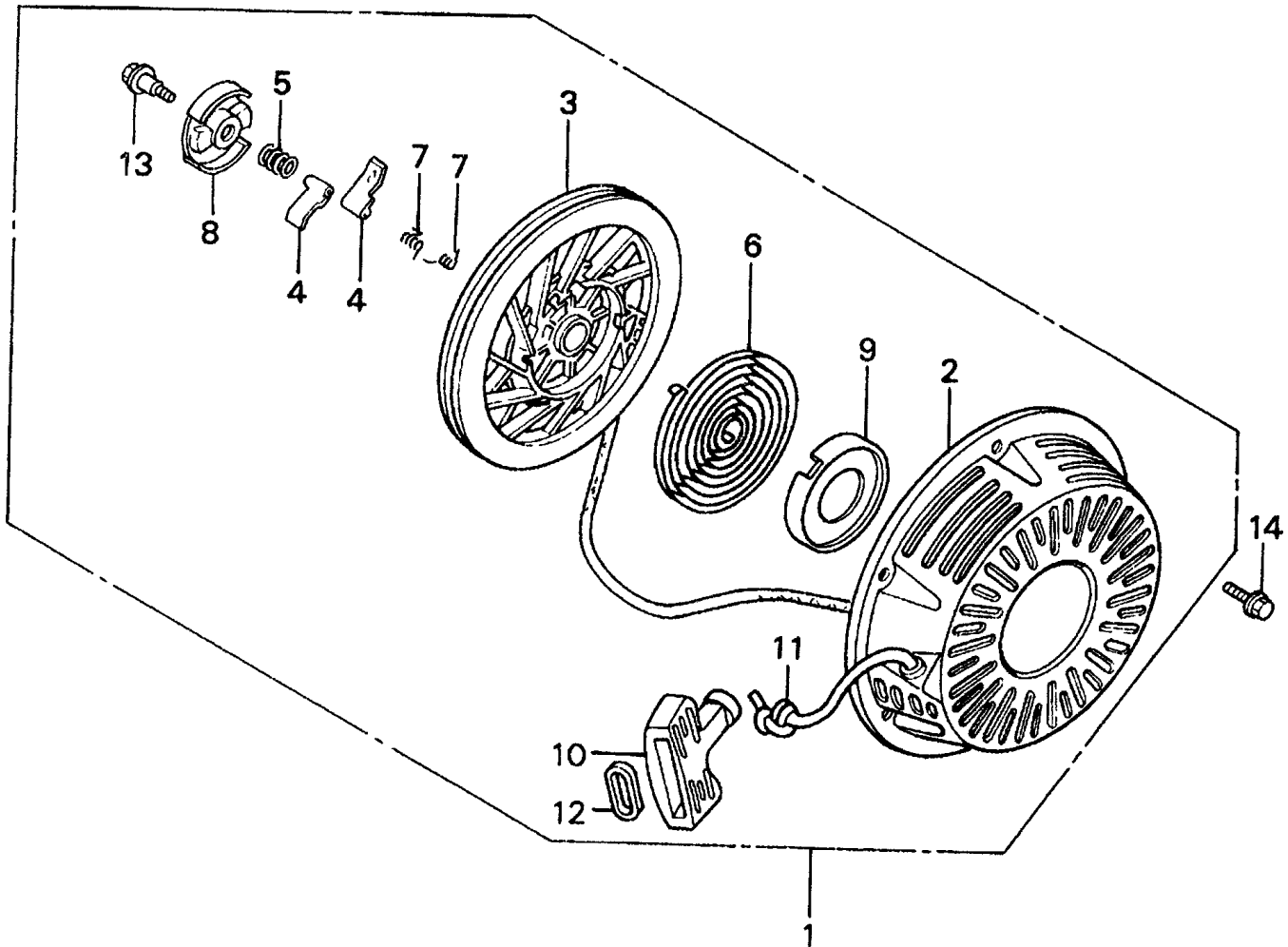

# HONDA GX340K1QA2 — RECOIL STARTER ASSY.

## RECOIL STARTER ASSY.

<u>NO.</u>	<u>PART NO.</u>	<u>PART NAME</u>	<u>QTY.</u>	<u>REMARKS</u>
1	28400ZEW01ZA	STARTER ASSY., RECOIL *R8* BGHT RED .....	1	INCLUDES ITEMS W/*
2	28410ZE3W01ZA	CASE, RECOIL STARTER *R8* BGHT RED	1	
3	28421ZE3W01	PULLEY, RECOIL STARTER	1	
4	28422ZE2W01	RATCHET, STARTER	2	
5	28441ZE2W01	SPRING, FRICTION	1	
6	28442ZE2W01	SPRING, STARTER RETURN	1	
7	28443ZE2W01	SPRING, RATCHET	2	
8	28444ZE2W01	RETAINER, SPRING	1	
9	28445ZE2W01	HOLDER, SPRING	1	
10	28461ZE2W02	GRIP, STARTER	1	
11	28462ZE3W01	ROPE, RECOIL STARTER	1	
12	28469ZE2W01	GRIP, REINFORCEMENT .....	1	USE UP TO ENG. SN 2935312
13	90004ZE2W01	SCREW, CENTER	1	
14	957010600800	BOLT, FLANGE 6X8	3	





# HONDA GX340K1QA2 — CONTROL ASSY.

## CONTROL ASSY.

<u>NO.</u>	<u>PART NO.</u>	<u>PART NAME</u>	<u>QTY.</u>	<u>REMARKS</u>
2	16551ZE3000	ARM, GOVERNOR	1	
3	16555ZE3000	ROD, GOVERNOR	1	
4	16561ZE3000	SPRING, GOVERNOR	1	
5	16562ZE3000	SPRING, THROTTLE RETURN	1	
7	16570ZE3W20	CONTROL ASSEMBLY, REMOTE	1	
8	16571ZE3W00	LEVER, CONTROL	1	
9	16574ZE1000	SPRING, LEVER	1	
10	16575ZE2W00	WASHER, CONTROL LEVER	1	
11	16576891000	HOLDER, CABLE	1	
12	16589ZE1000	SPACER, CONTROL LEVER	1	
14	16584883300	SPRING, CONTROL ADJUSTING	1	
15	16592883310	SPRING, CABLE RETURN	1	
17	90013883000	BOLT, FLANGE 6X12 (CT200)	2	
18	90015ZE5010	BOLT, GOVERNOR ARM	1	
19	90114SA0000	NUT, SELF- LOCK 6MM	1	
22	93500050320A	SCREW, PAN 5X32	1	
23	93500050160A	SCREW, PAN 5X16	1	
24	9405006000	NUT, FLANGE 6MM	1	

# HONDA GX340K1QA2 — LABELS ASSY.

LABELS ASSY.

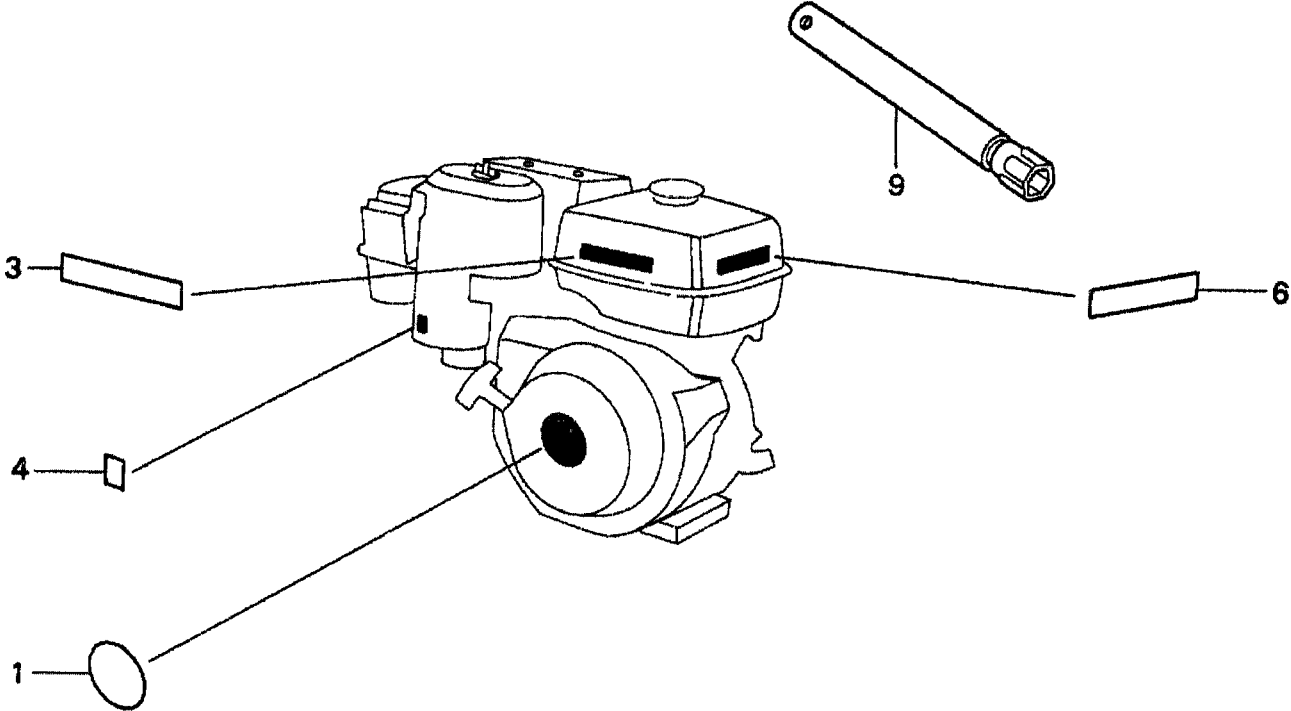

# HONDA GX340K1QA2 — LABELS ASSY.

## LABELS ASSY.

<u>NO.</u>	<u>PART NO.</u>	<u>PART NAME</u>	<u>QTY.</u>	<u>REMARKS</u>
1	87521ZE3W01	EMBLEM	1	
3	87522ZH9000	LABEL, CAUTION	1	
4	87528ZE2810	MARK, CHOKE (EXTERNAL)	1	
6	87532ZH8810	MARK, OIL ALERT (E)	1	
9	89218ZE1000	WRENCH, SPARK PLUG	1	

**PAYMENT TERMS**

Terms of payment for parts are net 10 days.

**FREIGHT POLICY**

All parts orders will be shipped collect or prepaid with the charges added to the invoice. All shipments are F.O.B. point of origin. Multiquip's responsibility ceases when a signed manifest has been obtained from the carrier, and any claim for shortage or damage must be settled between the consignee and the carrier.

**MINIMUM ORDER**

The minimum charge for orders from Multiquip is \$15.00 net. Customers will be asked for instructions regarding handling of orders not meeting this requirement.

**RETURNED GOODS POLICY**

Return shipments will be accepted and credit will be allowed, subject to the following provisions:

1. A Returned Material Authorization must be approved by Multiquip prior to shipment.
2. To obtain a Return Material Authorization, a list must be provided to Multiquip Parts Sales that defines item numbers, quantities, and descriptions of the items to be returned.
  - a. The parts numbers and descriptions must match the current parts price list.
  - b. The list must be typed or computer generated.
  - c. The list must state the reason(s) for the return.
  - d. The list must reference the sales order(s) or invoice(s) under which the items were originally purchased.
  - e. The list must include the name and phone number of the person requesting the RMA.
3. A copy of the Return Material Authorization must accompany the return shipment.

4. Freight is at the sender's expense. All parts must be returned freight prepaid to Multiquip's designated receiving point.
5. Parts must be in new and resalable condition, in the original Multiquip package (if any), and with Multiquip part numbers clearly marked.
6. The following items are not returnable:
  - a. Obsolete parts. (If an item is listed in the parts price book as being replaced by another item, it is obsolete.)
  - b. Any parts with a limited shelf life (such as gaskets, seals, "O" rings, and other rubber parts) that were purchased more than six months prior to the return date.
  - c. Anyline item with an extended dealer net price of less than \$5.00.
  - d. Special order items.
  - e. Electrical components.
  - f. Paint, chemicals, and lubricants.
  - g. Decals and paper products.
  - h. Items purchased in kits.
7. The sender will be notified of any material received that is not acceptable.
8. Such material will be held for 5 working days from notification, pending instructions. If a reply is not received within 5 days, the material will be returned to the sender at his expense.
9. Credit on returned parts will be issued at dealer net price at time of the original purchase, less a 15% restocking charge.
10. In cases where an item is accepted for which the original purchase document can not be determined, the price will be based on the list price that was effective twelve months prior to the RMA date.
11. Credit issued will be applied to future purchases only.

**PRICING AND REBATES**

Prices are subject to change without prior notice. Price changes are effective on a specific date and all orders received on or after that date will be billed at the revised price. Rebates for price declines and added charges for price increases will not be made for stock on hand at the time of any price change.

Multiquip reserves the right to quote and sell direct to Government agencies, and to Original Equipment Manufacturer accounts who use our products as integral parts of their own products.

**SPECIAL EXPEDITING SERVICE**

A \$20.00 to \$50.00 surcharge will be added to the invoice for special handling including bus shipments, insured parcel post or in cases where Multiquip must personally deliver the parts to the carrier.

**LIMITATIONS OF SELLER'S LIABILITY**

Multiquip shall not be liable here under for damages in excess of the purchase price of the item with respect to which damages are claimed, and in no event shall Multiquip be liable for loss of profit or good will or for any other special, consequential or incidental damages.

**LIMITATION OF WARRANTIES**

No warranties, express or implied, are made in connection with the sale of parts or trade accessories nor as to any engine not manufactured by Multiquip. Such warranties made in connection with the sale of new, complete units are made exclusively by a statement of warranty packaged with such units, and Multiquip neither assumes nor authorizes any person to assume for it any other obligation or liability whatever in connection with the sale of its products. A part from such written statement of warranty, there are no warranties, express, implied or statutory, which extend beyond the description of the products on the face hereof.



# PARTS AND OPERATION MANUAL

## **HERE'S HOW TO GET HELP**

*PLEASE HAVE THE MODEL AND SERIAL NUMBER  
ON-HAND WHEN CALLING*

### **PARTS DEPARTMENT**

*800-427-1244 or 310-537-3700*

*FAX: 800-672-7877 or 310-637-3284*

### **SERVICE DEPARTMENT/TECHNICAL ASSISTANCE**

*800-478-1244 or 310-537-3700*

*FAX: 310- 537-4259*

### **WARRANTY DEPARTMENT**

*888-661-4279, or 310-661-4279*

*FAX: 310- 537-1173*

### **MAIN**

*800-421-1244 or 310-537-3700*

*FAX: 310-537-3927*



#### **MULTIQUIP INC.**

POST OFFICE BOX 6254  
CARSON, CA 90749  
310-537-3700 • 800-421-1244  
FAX: 310-537-3927  
E-MAIL: [mq@multiquip.com](mailto:mq@multiquip.com)  
WWW: [multiquip.com](http://multiquip.com)

Atlanta • Boise • Dallas • Houston • Newark  
Quebec, Canada • Manchester, UK • Rio De Janeiro, BR • Guadalajara, MX

## Free Manuals Download Website

<http://myh66.com>

<http://usermanuals.us>

<http://www.somanuals.com>

<http://www.4manuals.cc>

<http://www.manual-lib.com>

<http://www.404manual.com>

<http://www.luxmanual.com>

<http://aubethermostatmanual.com>

Golf course search by state

<http://golfingnear.com>

Email search by domain

<http://emailbydomain.com>

Auto manuals search

<http://auto.somanuals.com>

TV manuals search

<http://tv.somanuals.com>