

OPERATION AND PARTS MANUAL



MODEL QP3TZ TRASH PUMP (Hatz 1B30 Diesel Engine)

Revision #3 (10/21/11)

To find the latest revision of this
publication, visit our website at:
www.multiquip.com



THIS MANUAL MUST ACCOMPANY THE EQUIPMENT AT ALL TIMES.



 WARNING 
CALIFORNIA — Proposition 65 Warning
Diesel engine exhaust and some of its constituents are known to the State of California to cause cancer, birth defects and other reproductive harm.

TABLE OF CONTENTS

MQ QP3TZ Trash Pump

Proposition 65 Warning	2
Table of Contents	4
Parts Ordering Procedures	5
Safety Information	6-10
Pump Specifications/Dimensions	11
Engine Specifications	12
General Information	13
Components	14
Basic Engine	15
Inspection	16
Setup	17
Operation	18
Maintenance (Pump)	19-20
Maintenance (Engine)	21-22
Preparation for Long-Term Storage	23
Troubleshooting	24-25
Explanation Of Code In Remarks Column	26
Suggested Spare Parts	27
Pump Assy.	28-31

Hatz 1B30 Diesel Engine

Spare Parts Kit Assembly	32-33
Accessories Assembly	34-35
Crankcase and Engine Mount Assembly	36-37
Crankshaft Assembly	38-39
Camshaft Assembly	40-41
Piston Assembly	42-43
Cylinder Head Assembly	44-45
Oil Pump/Governor Assembly	46-49
Timing Cover Assembly	50-51
Flywheel Assembly	52-53
Fuel Injection Assembly	54-57
Recoil Starter Assembly	58-59
Air Duct Assembly	60-63
Crankcase Breather Assembly	64-65
Fuel Tank Assembly (Old Style)	66-67
Fuel Tank Assembly (New Style)	68-71
Air Filter Assembly	72-73
Muffler Assembly	74-75
Sealing and Bonding Adhesives	76

Terms and Condition Of Sale — Parts 77

NOTICE

Specification and part number are subject to change without notice.

PARTS ORDERING PROCEDURE

Ordering parts has never been easier! Choose from three easy options:

Effective:
January 1st, 2006



Order via Internet (Dealers Only):

Order parts on-line using Multiquip's SmartEquip website!

- View Parts Diagrams
- Order Parts
- Print Specification Information



If you have an MQ Account, to obtain a Username and Password, E-mail us at: parts@multiquip.com.

To obtain an MQ Account, contact your District Sales Manager for more information.

Goto www.multiquip.com and click on

Order Parts to log in and save!

Use the **internet** and qualify for a **5% Discount** on *Standard orders* for all orders which include complete part numbers.*

Note: Discounts Are Subject To Change



Order via Fax (Dealers Only):

All customers are welcome to order parts via Fax.

Domestic (US) Customers dial:

1-800-6-PARTS-7 (800-672-7877)

Fax your order in and qualify for a **2% Discount** on *Standard orders* for all orders which include complete part numbers.*

Note: Discounts Are Subject To Change



Order via Phone: Domestic (US) Dealers Call:
1-800-427-1244

Non-Dealer Customers:

Contact your local Multiquip Dealer for parts or call 800-427-1244 for help in locating a dealer near you.



International Customers should contact their local Multiquip Representatives for Parts Ordering information.

When ordering parts, please supply:

- | | |
|---|--|
| <input type="checkbox"/> Dealer Account Number | <input type="checkbox"/> Specify Preferred Method of Shipment: |
| <input type="checkbox"/> Dealer Name and Address | <input checked="" type="checkbox"/> UPS/Fed Ex <input checked="" type="checkbox"/> DHL |
| <input type="checkbox"/> Shipping Address (if different than billing address) | <input type="checkbox"/> Priority One <input checked="" type="checkbox"/> Truck |
| <input type="checkbox"/> Return Fax Number | <input type="checkbox"/> Ground |
| <input type="checkbox"/> Applicable Model Number | <input type="checkbox"/> Next Day |
| <input type="checkbox"/> Quantity, Part Number and Description of Each Part | <input type="checkbox"/> Second/Third Day |

NOTICE

All orders are treated as *Standard Orders* and will ship the same day if received prior to 3PM PST.

WE ACCEPT ALL MAJOR CREDIT CARDS!



www.multiquip.com



SAFETY INFORMATION

Do not operate or service the equipment before reading the entire manual. Safety precautions should be followed at all times when operating this equipment. Failure to read and understand the safety messages and operating instructions could result in injury to yourself and others.



SAFETY MESSAGES

The four safety messages shown below will inform you about potential hazards that could injure you or others. The safety messages specifically address the level of exposure to the operator and are preceded by one of four words: **DANGER**, **WARNING**, **CAUTION** or **NOTICE**.

SAFETY SYMBOLS

⚠ DANGER

Indicates a hazardous situation which, if not avoided, **WILL** result in **DEATH** or **SERIOUS INJURY**.

⚠ WARNING

Indicates a hazardous situation which, if not avoided, **COULD** result in **DEATH** or **SERIOUS INJURY**.







⚠ CAUTION

Indicates a hazardous situation which, if not avoided, **COULD** result in **MINOR** or **MODERATE INJURY**.

NOTICE

Addresses practices not related to personal injury.

Potential hazards associated with the operation of this equipment will be referenced with hazard symbols which may appear throughout this manual in conjunction with safety messages.

Symbol	Safety Hazard
	Lethal exhaust gas hazards
	Explosion hazards
	Burn hazards
	Pressurized fluid hazards
	Battery acid hazards
	Eye safety hazards

SAFETY INFORMATION

GENERAL SAFETY

CAUTION

- **NEVER** operate this equipment without proper protective clothing, shatterproof glasses, respiratory protection, hearing protection, steel-toed boots and other protective devices required by the job or city and state regulations.



- **NEVER** operate this equipment when not feeling well due to fatigue, illness or when under medication.



- **NEVER** operate this equipment under the influence of drugs or alcohol.



NOTICE

- This equipment should only be operated by trained and qualified personnel 18 years of age and older.
- Whenever necessary, replace nameplate, operation and safety decals when they become difficult to read.
- Manufacturer does not assume responsibility for any accident due to equipment modifications. Unauthorized equipment modification will void all warranties.
- **NEVER** use accessories or attachments that are not recommended by Multiquip for this equipment. Damage to the equipment and/or injury to user may result.
- **ALWAYS** know the location of the nearest **fire extinguisher**.
- **ALWAYS** know the location of the nearest **first aid kit**.
- **ALWAYS** know the location of the nearest phone or **keep a phone on the job site**. Also, know the phone numbers of the nearest **ambulance, doctor** and **fire department**. This information will be invaluable in the case of an emergency.



PUMP SAFETY

DANGER

- **NEVER** pump volatile, explosive, flammable or low flash point fluids. These fluids could ignite or explode.
- The engine fuel exhaust gases contain poisonous carbon monoxide. This gas is colorless and odorless, and can cause death if inhaled.
- The engine of this equipment requires an adequate free flow of cooling air. **NEVER** operate this equipment in any enclosed or narrow area where free flow of the air is restricted. If the air flow is restricted it will cause injury to people and property and serious damage to the equipment or engine.



- **NEVER** operate the equipment in an explosive atmosphere or near combustible materials. An explosion or fire could result causing severe **bodily harm or even death**.



WARNING

- **NEVER** pump corrosive chemicals or water containing toxic substances. These fluids could create serious health and environmental hazards. Contact local authorities for assistance.
- **NEVER** open the priming plug when pump is hot. Hot water inside could be pressurized much like the radiator of an automobile. Allow pump to cool to the touch before loosening plug. The possibility exists of scalding, resulting in severe bodily harm.
- **NEVER** disconnect any **emergency or safety devices**. These devices are intended for operator safety. Disconnection of these devices can cause severe injury, bodily harm or even death. Disconnection of any of these devices will void all warranties.



SAFETY INFORMATION

CAUTION

- **NEVER** lubricate components or attempt service on a running machine.
- **NEVER** block or restrict flow from discharge hose. Remove kinks from discharge line before starting pump. Operation with a blocked discharge line can cause water inside pump to overheat.

NOTICE

- **ALWAYS** fill the pump casing with water before starting the engine. Failure to maintain water inside the pump housing will cause severe damage to the pump and mechanical seal.
- In winter drain water from pump housing to prevent freezing.
- **NEVER** start the pump with the clean-out cover removed. The rotating impeller inside the pump can cut or sever objects caught in it. Before starting the pump, check that the clean-out cover is securely fastened.
- **ALWAYS** keep the machine in proper running condition.
- **ALWAYS** ensure pump is on level ground before use.
- Fix damage to machine and replace any broken parts immediately.
- **ALWAYS** store equipment properly when it is not being used. Equipment should be stored in a clean, dry location out of the reach of children and unauthorized personnel.

ENGINE SAFETY

WARNING

- **NEVER** operate the engine with heat shields or guards removed.
- **DO NOT** remove the engine oil drain plug while the engine is hot. Hot oil will gush out of the oil tank and severely scald any persons in the general area of the pump.



CAUTION

- **NEVER** touch the hot exhaust manifold, muffler or cylinder. Allow these parts to cool before servicing equipment.



NOTICE

- **NEVER** run engine without an air filter or with a dirty air filter. Severe engine damage may occur. Service air filter frequently to prevent engine malfunction.
- **NEVER** tamper with the factory settings of the engine or engine governor. Damage to the engine or equipment can result if operating in speed ranges above the maximum allowable.





SAFETY INFORMATION

FUEL SAFETY

DANGER

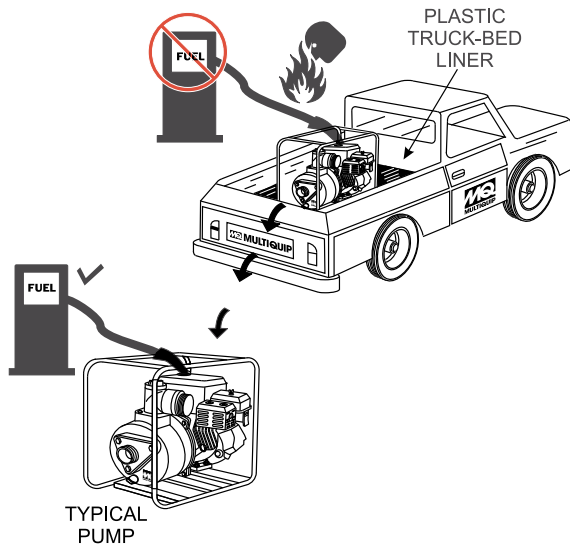
- **DO NOT** add fuel to equipment if it is placed inside truck bed with plastic liner. Possibility exists of explosion or fire due to static electricity.



- **DO NOT** start the engine near spilled fuel or combustible fluids. Fuel is extremely flammable and its vapors can cause an explosion if ignited.
- **ALWAYS** refuel in a well-ventilated area, away from sparks and open flames.
- **ALWAYS** use extreme caution when working with **flammable** liquids.
- **DO NOT** fill the fuel tank while the engine is running or hot.
- **DO NOT** overfill tank, since spilled fuel could ignite if it comes into contact with hot engine parts or sparks from the ignition system.
- Store fuel in appropriate containers, in well-ventilated areas and away from sparks and flames.
- **NEVER** use fuel as a cleaning agent.
- **DO NOT** smoke around or near the equipment. Fire or explosion could result from fuel vapors or if fuel is spilled on a hot engine. 

BATTERY SAFETY (ELECTRIC START ONLY)

DANGER

- **DO NOT** drop the battery. There is a possibility that the battery will explode.
- **DO NOT** expose the battery to open flames, sparks, cigarettes, etc. The battery contains combustible gases and liquids. If these gases and liquids come into contact with a flame or spark, an explosion could occur. 

WARNING

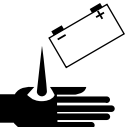
- **ALWAYS** wear safety glasses when handling the battery to avoid eye irritation. The battery contains acids that can cause injury to the eyes and skin. 
- Use well-insulated gloves when picking up the battery.
- **ALWAYS** keep the battery charged. If the battery is not charged, combustible gas will build up.
- **DO NOT** charge battery if frozen. Battery can explode. When frozen, warm the battery to at least 61°F (16°C).
- **ALWAYS** recharge the battery in a well-ventilated environment to avoid the risk of a dangerous concentration of combustible gases.
- If the battery liquid (dilute sulfuric acid) comes into contact with **clothing or skin**, rinse skin or clothing immediately with plenty of water. 
- If the battery liquid (dilute sulfuric acid) comes into contact with **eyes**, rinse eyes immediately with plenty of water and contact the nearest doctor or hospital to seek medical attention.

CAUTION

- **ALWAYS** disconnect the **NEGATIVE** battery terminal before performing service on the equipment.
- **ALWAYS** keep battery cables in good working condition. Repair or replace all worn cables.

SAFETY INFORMATION

TRANSPORTING SAFETY

⚠ CAUTION

- **NEVER** allow any person or animal to stand underneath the equipment while lifting.

NOTICE

- Before lifting, make sure that the equipment parts (hook and vibration insulator) are not damaged and screws are not loose or missing.
- Always make sure crane or lifting device has been properly secured to the lifting bail (hook) of the equipment.
- **ALWAYS** shutdown engine before transporting.
- **NEVER** lift the equipment while the engine is running.
- Tighten fuel tank cap securely and close fuel cock to prevent fuel from spilling.
- Use adequate lifting cable (wire or rope) of sufficient strength.
- Use one point suspension hook and lift straight upwards.

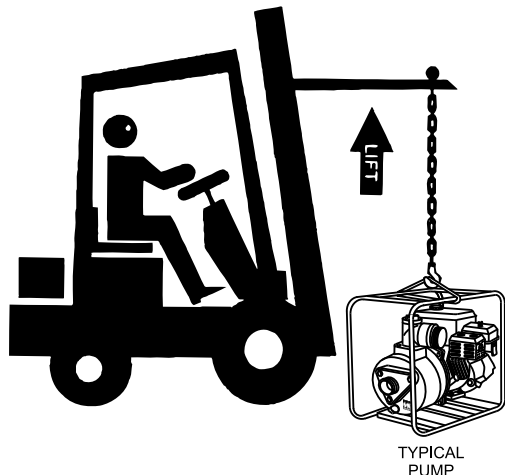

- **DO NOT** lift machine to unnecessary heights.
- **ALWAYS** tie down equipment during transport by securing the equipment with rope.

ENVIRONMENTAL SAFETY

NOTICE

- Dispose of hazardous waste properly. Examples of potentially hazardous waste are used motor oil, fuel and fuel filters. 
- **DO NOT** use food or plastic containers to dispose of hazardous waste.
- **DO NOT** pour waste, oil or fuel directly onto the ground, down a drain or into any water source.

SPECIFICATIONS/DIMENSIONS (PUMP)

Table 1. Specifications (Pump)		
Pump	Model	QP3TZ
	Type	Trash Pump
	Suction & Discharge Size	3.00 in. (76 mm.)
	Maximum Pumping Capacity	383 gallons/minute (1,450 liters/minute)
	Max. Solids Diameter	1.50 in. (38 mm.)
	Max. Lift	25 ft. (7.62 meters)
	Max. Head	90 ft. (27.0 meters)
Dimension (L x W x H)	27.8 x 20.0 X 25.0 in. (705 X 510 X 635 mm.)	
Dry Net Weight	163 lbs. (74 Kg.)	

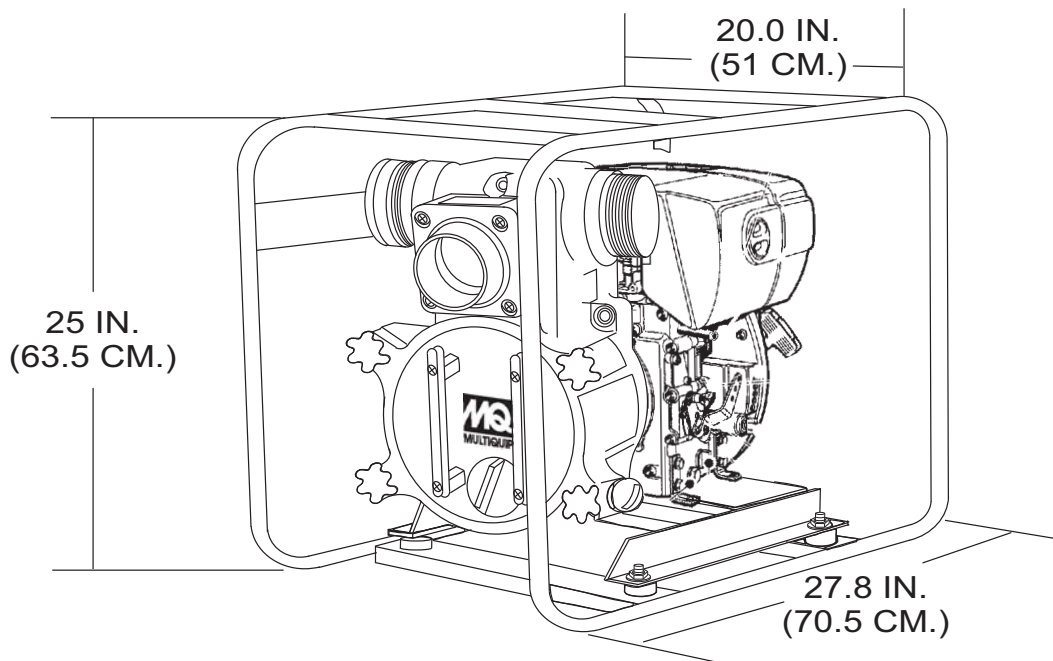
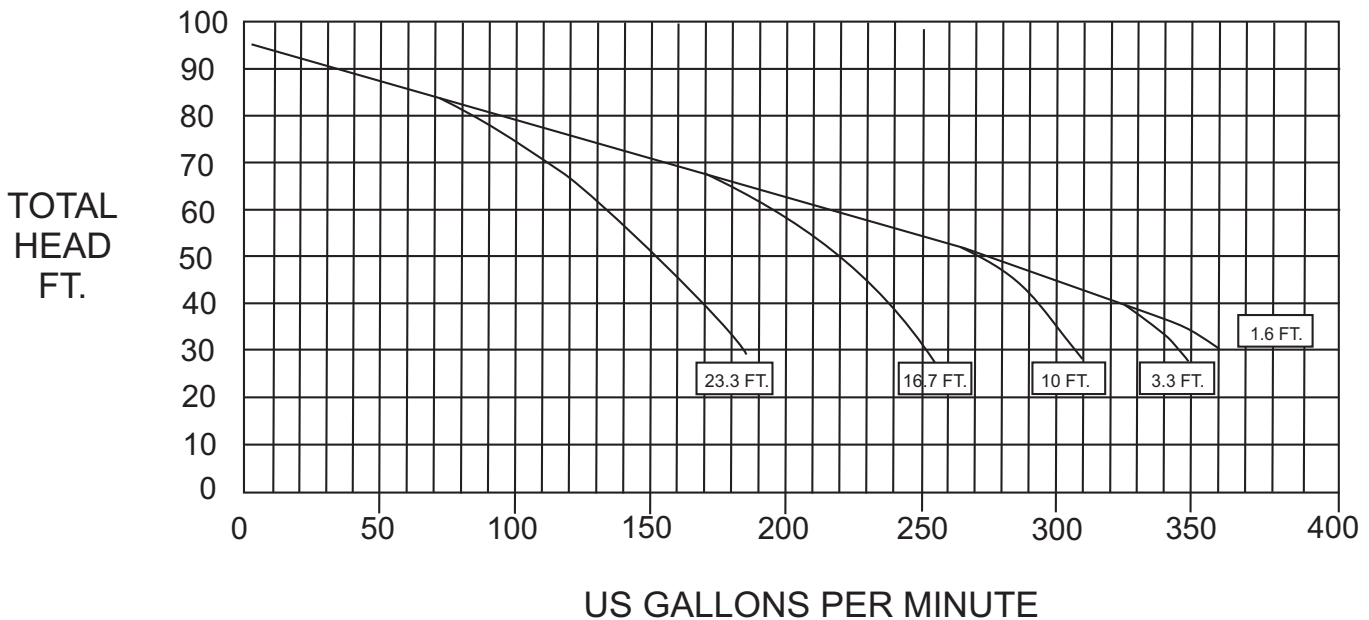

Figure 1. QP3TZ Dimensions

SPECIFICATIONS (ENGINE)

Table 2. Engine Specifications (HATZ 1B30)

HATZ Diesel Model 1B30 Air-Cooled	No. Cylinders	Displacement	Idle Speed	Lube Oil Capacity	Type Air Cleaner	Starting Method	Weight
	1	347 cu. cm. (.347 liters)	800 RPM's	1.16 qts. (1.1 liters)	Dry Element	Recoil Start	88.18 lbs. (40 kg.)
Engine Oil Type	CCMC - D4 - D5 - PD@ or API - CD-CE - CF -CG or SHPD						
Type Fuel	EN 590 - DIN 51601 BS 2869 A1/A2-ASTM D 975-1D/2D						



APPLICATION

The **QP3TZ Trash Pump** is designed to be used for dewatering applications. Both the suction and discharge ports on the QP3TZ trash pump use a 3-inch diameter opening, which allows the pump to pump at a rate of approximately 383 gallons/minute (gpm) or 1,450 liters/minute (lpm).

Trash or self-priming pumps are designed to purge air from the suction line and create a partial vacuum in the pump body. The reduced atmospheric pressure inside the pump allows water to flow through the suction line and into the pump body. The centrifugal force created by the rotating impeller pressurizes the water and expels it from the pump.

Engine

This trash pump is powered by a 6.8 horsepower, air-cooled, **HATZ 1B30** diesel engine.

Trash Pump

Trash pumps derive their name from their ability to handle a greater amount of debris and solids than standard centrifugal pumps. This pump generally handle solids up to 1/2 the size of the discharge opening making them less likely to clog. Also trash pumps are capable of handling water with 25% solids by weight.

The advantage of using a trash pump is that it can be quickly and easily disassembled in the field "**without tools**" and easily cleaned when clogged.

Suction Lift

This pump is intended to be used for dewatering applications and is capable of suction lifts up to 25 feet at sea level. For optimal suction lift performance, keep the suction hose or line as short as possible. In general, always place the pump as close to the water as possible.

Pump Support

The pump should always be placed on **solid stationary ground** in a level position.

NEVER place the pump on **soft soil**. The suction hose or pipe connection should always be checked for tightness and leaks. A small suction leak in the hose or fittings could prevent the pump from priming.

Elevation

Higher elevations will effect the performance of the pump. Due to less atmospheric pressure at higher altitudes, pumps **DO NOT** have the priming ability that they have at sea level. This is due to the "thinner air" or lack of oxygen at higher altitudes.

A general rule of thumb is that for every 1,000 feet of elevation above sea level a pump will lose one foot of priming ability.

For example, in Flagstaff, Arizona where the elevation is approximately 7,000 feet, the pump would have a suction lift of 25 feet rather than the 18 feet at sea level. Table 3 shows suction lift at various elevations.

Altitude Feet (Meters)	Suction Lift in Feet (Meters)			
Sea Level	10.0 (3.048)	15.0 (4.572)	20.0 (6.096)	25.0 (7.620)
2,000 (610)	8.80 (2.680)	13.2 (4.023)	17.6 (5.364)	22.0 (6.705)
4,000 (1,219)	7.80 (2.377)	11.7 (3.566)	15.6 (4.754)	19.5 (5.943)
6,000 (1,829)	6.90 (2.103)	10.4 (3.169)	13.8 (4.206)	17.3 (5.273)
8,000 (2,438)	6.20 (1.889)	9.30 (2.834)	12.4 (3.779)	15.5 (4.724)
10,000 (3,048)	5.70 (1.737)	8.60 (2.621)	11.4 (3.474)	14.3 (4.358)

Table 4 shows percentage drops in performance as elevation increases.

Altitude Feet (Meters)	Discharge Flow	Discharge Head
Sea Level	100%	100%
2,000 (610)	97%	95%
4,000 (1,219)	95%	91%
6,000 (1,829)	93%	87%
8,000 (2,438)	91%	83%
10,000 (3,048)	88%	78%

Figure 2 shows a typical application using the QP3TZ Trash pump. Please note that this pump is intended for the removal of clean water and water containing some debris and solids. Maximum size of solids should not exceed 1.5 inch (30 mm) in diameter. **DO NOT** set strainer on bottom of water bed. Placing the strainer above the water bed will prevent the pump from drawing in excessive amounts of sand and foreign debris.

Figure 2. QP3TZ Pump Application

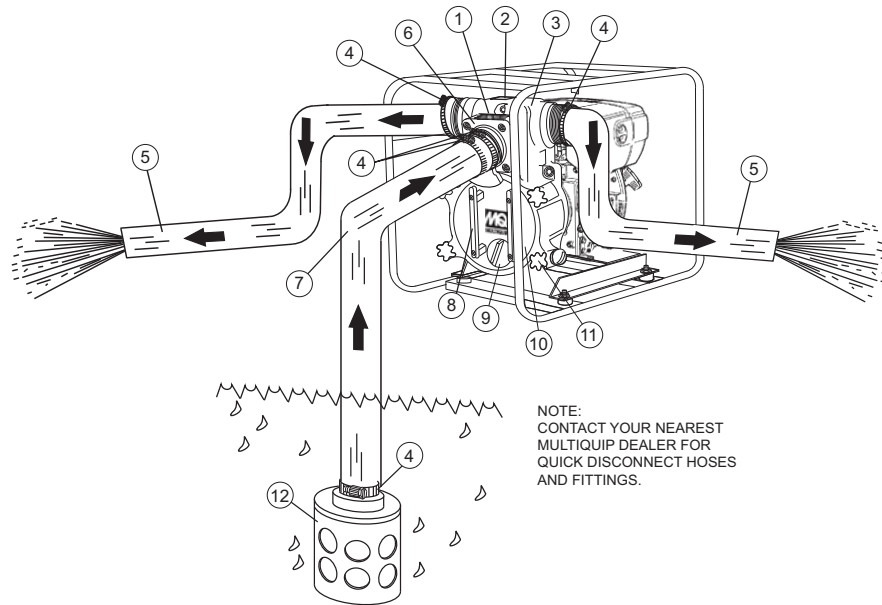

1. **Pump** – The model QP3TZ is a 3-inch trash pump used in general dewatering applications. Typical dewatering applications consist of manholes, septic tanks, fast and slow seepage ditch water, silt water, mud water and muck water.
2. **Fill Cap** – Prior to operation, the pump casing should be filled with water. Remove this cap to add water to the pump. After the initial prime, a sufficient amount of water will be retained in the casing so that the operator will not need to re-prime later.
If the casing is dry or has insufficient water, the pump will have difficulty in priming which could lead to premature mechanical seal wear thus causing damage to the pump.
3. **Discharge Port** – Connect a 3-inch discharge hose to either port (one of two ports).
4. **Worm Clamp** – Used to secure the hose to the inlet and outlet ports on the pump. Use two clamps to secure the hose on the inlet side of the pump.
5. **Discharge Hose** – Connect this flexible rubber hose to the discharge port on the pump. Make sure that the hose lays flat and is not kinked. Use only recommended type discharge hose. Contact Multiquip Parts Department for ordering information.
6. **Suction Port** – Connect a 3-inch inlet hose to this port. Use two worm clamps to secure the hose.
7. **Suction Hose** – Connect this flexible rubber hose to the suction portion the pump. Make sure that the hose lays flat and is not kinked. Use only recommended type suction hose. Contact Multiquip Parts Department for ordering information.
8. **Clean-out Cover Handles** – To gain access to the pump's clean-out area, grip both handles, then pull to remove cover. Make sure both locking knobs have been released before attempting to remove clean-out cover.
9. **Drain Plug** – Remove this plug to drain water from the pump.
10. **Clean-out Cover** – Remove cover to gain access to the clean-out area.
11. **Locking Knobs** – Turn both knobs clockwise to secure clean-out cover, turn counterclockwise to release cover.
12. **Strainer** – Always attach a strainer to the bottom side of the suction hose to prevent large objects and debris from entering the pump. Strainer should be positioned so that it will remain completely under water. Running the pump with the strainer above water for long periods can damage pump.

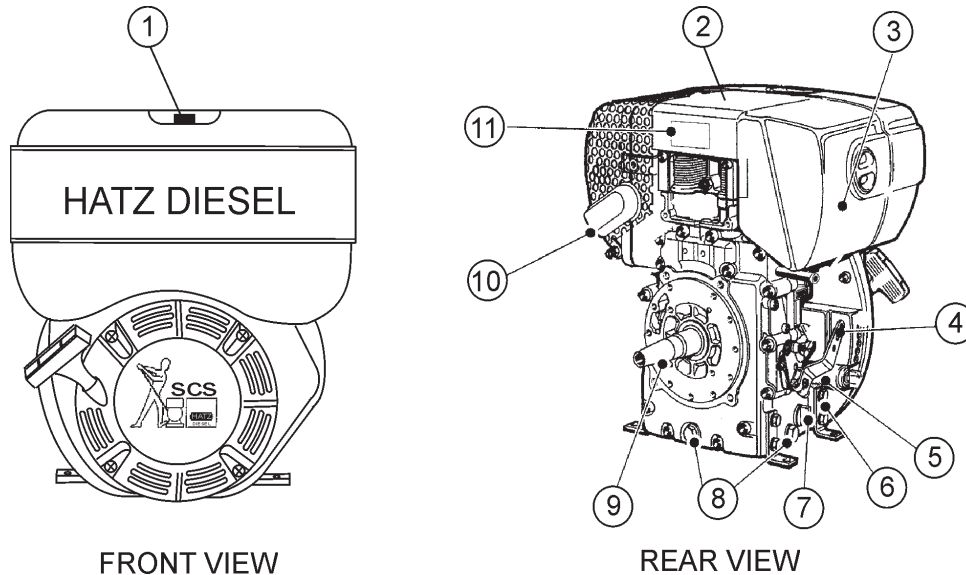

Figure 4. Engine Controls and Components

INITIAL SERVICING

The engine (Figure 4) must be checked for proper lubrication and filled with fuel prior to operation. Refer to the manufacturer's Engine manual for instructions & details of operation and servicing.

1. **Fuel Filler Cap/Fuel Tank** – Pull this latch to add *diesel* fuel to the tank. After refueling, always make sure the fuel cap is latched properly. **DO NOT** over fill. For additional information refer to engine owner's manual.

WARNING



Add fuel to the tank only when the engine is stopped and has cooled down. In the event of a fuel spill, **DO NOT** attempt to start the engine until the fuel residue has been completely wiped up and the area surrounding the engine is dry.

2. **Engine Lifting Straps/Cover** – Remove the air cleaner cover, then lift this cover (the one with decals on it) to gain access to the engine lifting straps.
3. **Air Cleaner/Cover** – Prevents dirt and other debris from entering the fuel system. Remove wing-nut on side of air filter cover to gain access to filter element.
4. **Speed Control Lever** – This lever is connected to the throttle control which is located on the side of the engine compartment cover. Use this lever to control engine speed.
5. **Dipstick** – Remove dipstick to determine if the engine oil level is low. If low, add oil as specified.

6. **Engine Motor Mounts** – Attach these engine mounts to the pump frame. Tighten securely.
7. **Oil Filter** – Remove this bolt to gain access (internal) to the engine oil filter. Service the oil filter as recommended in the maintenance section of this manual.
8. **Oil Drain Plugs** – There are two oil drain plugs, one is underneath the flywheel, the other on the side of the engine. Remove these plugs to drain engine oil from the engine crankcase.
9. **Crankshaft** – Connect this shaft to the input of the transmission.
10. **Muffler** – Used to reduce noise and emissions.
11. **Nameplate** – Contains information about the engine.

WARNING



Engine components can generate extreme heat. To prevent burns, **DO NOT** touch these areas while the engine is running or immediately after operating. **NEVER** operate the engine with the muffler removed.

NOTICE

Operating the engine without an air filter, with a damaged air filter, or a filter in need of replacement will allow dirt to enter the engine, causing rapid engine wear.

CAUTION



NEVER operate the pump in a confined area or enclosed area structure that does not provide ample **free flow of air**.

CAUTION



ALWAYS wear approved eye and hearing protection before operating the pump.

Before Starting

1. Read safety instructions at the beginning of manual.
2. Clean the pump, removing dirt and dust, particularly the engine cooling air inlet, carburetor and air cleaner.
3. Check the air filter for dirt and dust. If air filter is dirty, replace air filter with a new one as required.
4. Check carburetor for external dirt and dust. Clean with dry compressed air.
5. Check fastening nuts and bolts for tightness.



Engine Oil Check

1. To check the engine oil level, place the pump on secure level ground with the engine stopped.
2. Remove the filler dipstick from the engine oil filler hole (Figure 5) and wipe clean.

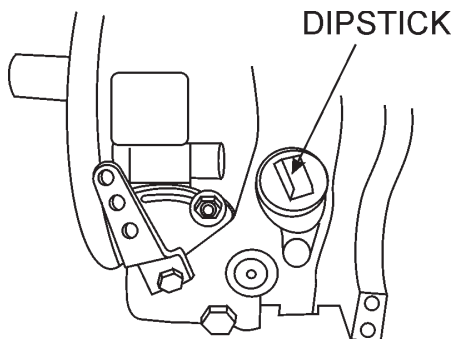

Figure 5. Engine Oil Dipstick (Removal)

3. Insert and remove the dipstick without screwing it into the filler neck. Check the oil level shown on the dipstick.
4. If the oil level is low (Figure 6), fill to the edge of the oil filler hole with the recommended oil type (Table 5). Maximum oil capacity is 1.16 quarts (1.1 liters)

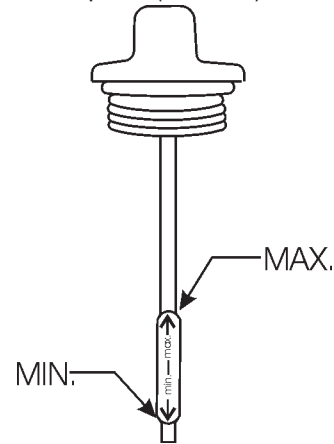
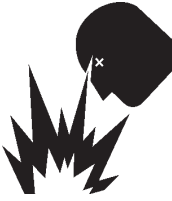

Figure 6. Engine Oil Dipstick (Oil Level)

Table 5. Oil Type

Season	Temperature	Oil Type
Summer	25°C or Higher	SAE 10W-30
Spring/Fall	25°C~10°C	SAE 10W-30/20
Winter	0°C or Lower	SAE 10W-10

DANGER



EXPLOSIVE FUEL!

Motor fuels are highly flammable and can be dangerous if mishandled. **DO NOT** smoke while refueling. **DO NOT** attempt to refuel if the engine is **hot** or **running**.

Fuel Check

1. Remove the gasoline cap located on top of fuel tank.
2. Visually inspect to see if the fuel level is low. If fuel is low, replenish with unleaded fuel.
3. When refueling, be sure to use a strainer for filtration. **DO NOT** top-off fuel. Wipe up any spilled fuel **immediately!**

Before Starting

1. Read safety instructions at the beginning of manual.
2. Place pump as near to water as possible, on a firm flat, level surface.
3. To prime pump, remove fill cap (Figure 2) and fill pump casing with water. If the pump casing is not filled with water before starting, it will not begin pumping.

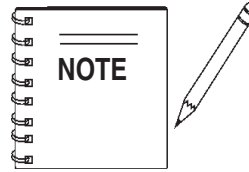

Suction and discharge hoses are available from Multiquip. Contact your nearest dealer for more information.

NOTICE

Pump casing **must** be filled with water before using pump. Otherwise pump will not be able to begin pumping.

WARNING

DO NOT open **fill cap** if pump is **hot!** Water inside may be under pressure.

4. Check for **leaks** between pump and engine. If water is leaking between the pump and engine housing, the seal inside the pump may be worn or damaged. Continued operation of the pump is not recommended. Further usage of the pump under these conditions may cause severe water damage to engine.

Hoses and Clamps

1. Check that all hoses are **securely** attached to the pump. Make certain suction hose (Figure 2) does not have any air leakage. Tighten hose clamps and couplings as required.
2. It is recommended that 2 clamps be used when securing the suction hose to the inlet side (suction) of the pump.
3. Remember suction hoses must be **rigid** enough not to collapse when the pump is in operation.
4. Check that the **discharge** hose (Figure 2) is not restricted. Place hose so that it lays as straight as it is possible on the ground. Remove any twists or sharp bends from hose which may block the flow of water.

5. The discharge hose is usually a **collapsible** (thin-walled) hose, however if a thin-walled discharge hose is not available, a rigid suction hose can be substituted in its place.
6. Make sure the **suction strainer** (Figure 2) is clean and securely attached to the water end of the suction hose. The strainer is designed to protect the pump by preventing large objects from being pulled into the pump.

CAUTION

The strainer should be positioned so it will remain completely **under water**. Running the pump with the strainer above water for long periods can damage the pump.

CAUTION

DO NOT pump flammable fluids, corrosive chemicals or fluids containing toxic substances. These fluids can create potentially dangerous health and environmental hazards. Contact local authorities for assistance.

CAUTION

This pump uses a water-cooled **mechanical seal** to prevent water from seeping into the engine. The passage of water through the pump casing lubricates the seal and prevents it from overheating. **NEVER** operate the pump without water in the casing as this will cause damage to the mechanical seal.

CAUTION



DO NOT attempt to operate the pump until the Safety, General Information and Inspection sections of this manual have been **read and thoroughly understood**.

This section is intended to assist the operator with the **initial start-up** of the trash pump. It is extremely important that this section be read carefully before attempting to use the pump in the field.

Starting the Engine (HATZ engine)

3. Move the engine speed lever to the **START** position (Figure 8).

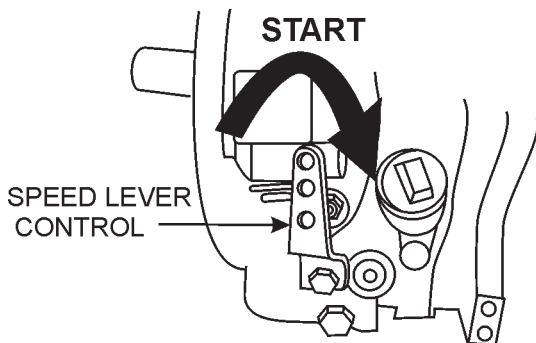

Figure 8. Engine Speed Lever (START position)

4. Grasp the starter grip (Figure 9) and slowly pull it out until you feel the strongest resistance then return the starter grip to the initial position.

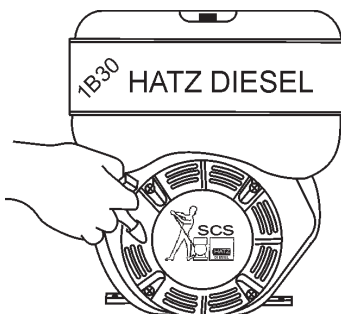

Figure 9. Starter Grip

CAUTION

Do not allow the starter grip to snap back against the engine. Return it gently to prevent damage to the starter.

5. Pull the starter grip again, hard and fast, pulling it all the way out to start engine.
6. If the engine does not start, repeat steps 4 and 5.

CAUTION

ALWAYS run engine at **full speed** while pumping.

Stopping The Engine

Normal Shutdown

1. Move the engine speed lever to the low speed and run the engine for about three minutes with no load.
2. After the engine cools, move the engine speed lever to the **STOP** position (Figure 11).

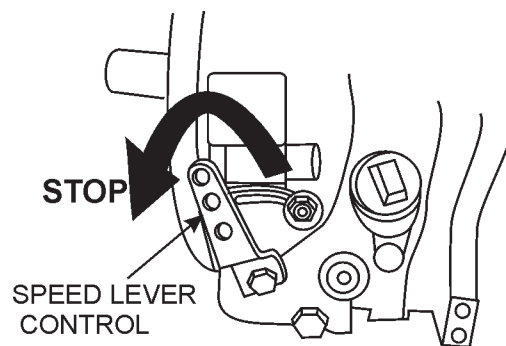

Figure 11. Engine Speed Lever (STOP Position)

4. Slowly pull the starter grip (Figure 9) until strong resistance is felt and leave it in this position. This prevents rust from forming while the engine is not in use.

CAUTION

When stopping the engine, reduce the load slowly. Do not stop engine suddenly since it may cause the temperature to rise abnormally.

Emergency Shutdown

1. To stop engine immediately, quickly place the engine speed lever to the STOP position.

Pump Vacuum Test

NOTICE

DO NOT attempt to start the engine unless the pump has previously been **primed** with water. Severe pump damage will occur if pump has not been primed.

To perform the pump vacuum test do the following:

1. Remove the pump fill cap (Figure 2), and fill the pump with water.
2. Start the engine as outlined in the initial start-up section, and wait for the pump to begin pumping.
3. As shown in Figure 13, place a water hose inside the discharge opening of the pump, and turn on the water. This flow of water into the discharge opening will **prevent** the pump from running dry.
4. Place the **Pump Vacuum Tester** (P/N 7000030) over the pump suction (inlet) opening (Figure 13) with the vacuum gauge facing upwards. It may be necessary to apply a small amount of water around the rubber seal of the vacuum tester to make a good suction fit.
5. Check and make sure that there are no air leaks between the vacuum tester and the inlet port on the pump. If air leaks are present reset vacuum tester.
6. Run the pump for a few minutes while monitoring the vacuum gauge. If the gauge indicates a reading between -25 and -20 in. Hg. (inches of mercury), then it can be assumed that the pump is working correctly.

NOTICE

25 in. Hg. (inches of mercury) translates into 25 feet of lift at **sea level**.

7. If the vacuum tester gauge indicates a reading **below** -20 in. Hg, it can then be assumed that the pump is not functioning correctly, and corrective action needs to be taken.
6. To test the **flapper valve**, shut down the engine. The vacuum tester should remain attached to the pump suction inlet port by vacuum. This indicates the pump's flapper valve is seating properly to hold water in the suction hose when the engine is stopped. This prevents backflow and allows for faster priming when the engine is restarted.

Adjusting Impeller Clearance

1. If it is necessary to replace impeller or volute, be sure clearance between impeller and volute is adjusted correctly.
2. The impeller should be as close to the volute as possible without rubbing against it. Clearance is adjusted by adding or removing **shims** from behind the impeller.
3. Check clearance between impeller and insert by slowly pulling starter rope to turn impeller. Remove spark plug to make it easier to turn impeller.

NOTICE

It is important not to remove too many shims or the clearance between the impeller and volute will become **too wide** and pump performance will be reduced. Remember as the impeller wears down, additional shims may be required to maintain the clearance between the impeller and insert.

4. Check the impeller **every six months** for wear, and for clearance between the impeller face and the volute. Also check the shaft seal for wear, as well as the shaft sleeve.

Pump Cleaning

After pumping water containing large amounts of dirt and debris, perform the following:

1. Remove the drain plug from the pump housing (Figure 2) and drain any water left in the pump.
2. Loosen the two locking hand knobs (turn counterclockwise) and remove **clean-out cover**.
3. Clean and remove dirt, debris from pump casing. Inspect impeller and volute for wear. Replace any damaged or worn parts.

CAUTION

The impeller may develop **sharp edges**. Use extreme care when cleaning around the impeller to prevent being cut.

CAUTION

**DO NOT RUN PUMP
WITHOUT WATER.**

PLACE VACUUM TESTER
OVER PUMP SUCTION PORT

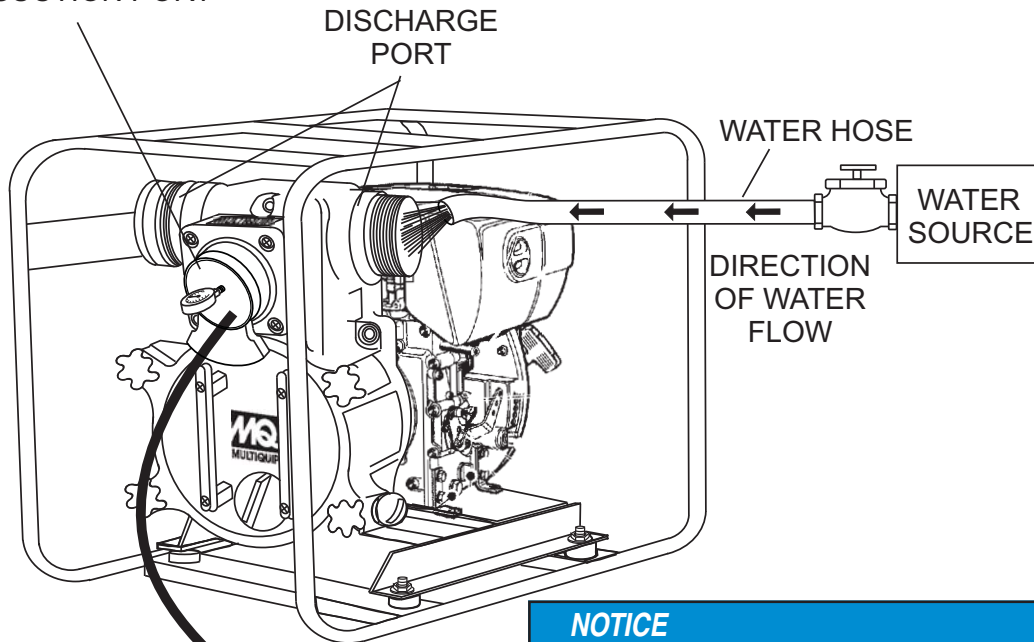

NOTICE

Pressure reading may vary depending on altitude. See Tables 3 and 4.

ACCEPTABLE READING
SHOULD BE BETWEEN
-25 AND -20 IN. HG.

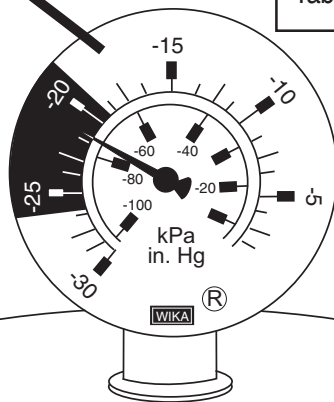

25 IN. HG. TRANSLATES
INTO 25 FEET OF LIFT
AT SEA LEVEL.

PUMP VACUUM
TESTER

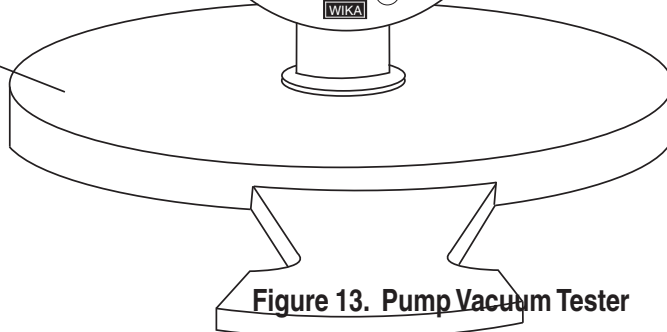

Figure 13. Pump Vacuum Tester

Engine Maintenance

Perform engine maintenance procedures as referenced by Table 6 below:

Table 6. Engine Maintenance Schedule							
DESCRIPTION (3)	OPERATION	BEFORE	FIRST MONTH OR 10 HRS.	EVERY 3 MONTHS OR 25 HRS.	EVERY 6 MONTHS OR 50 HRS.	EVERY YEAR OR 100 HRS.	EVERY 2 YEARS OR 200 HRS.
Engine Oil	CHECK	X					
	CHANGE		X				
Air Cleaner	CHECK	X					
	CHANGE			X (1)			
All Nuts & Bolts	Re-tighten If Necessary	X					
Cooling Fins	CHECK				X		
Spark Arrester	CLEAN					X	
Fuel Tank	CLEAN					X	
Fuel Filter	CHECK					X	
Idle Speed	CHECK-ADJUST					X (2)	
Valve Clearance	CHECK-ADJUST						X (2)
Fuel lines	CHECK	Every 2 years (replace if necessary) (2)					

(1) Service more frequently when used in **DUSTY** areas.

(2) These items should be serviced by your service dealer, unless you have the proper tools and are mechanically proficient. Refer to the HATZ shop manual for service procedures.

(3) For commercial use, log hours of operation to determine proper maintenance intervals.

NOTICE

Refer to engine manual for specific servicing instructions.

Maintenance

Perform the engine maintenance procedures as indicated below:

DAILY

- Thoroughly remove dirt and oil from the engine and control area. Clean or replace the air cleaner elements as necessary. Check and retighten all fasteners as necessary. Check the spring box and bellows for oil leaks. Repair or replace as needed.

WEEKLY

- Remove the fuel filter cap and clean the inside of the fuel tank.
- Remove or clean the filter at the bottom of the tank.

ENGINE OIL

1. Drain the engine oil when the oil is **warm** as shown in Figure 14.
2. Remove the oil drain bolt and sealing washer and allow the oil to drain into a suitable container.
3. Replace engine oil with recommended type oil as listed in Table 5. Engine oil capacity is 1.16 quarts (1.1 liters). **DO NOT** overfill.
4. Install drain bolt with sealing washer and tighten securely.

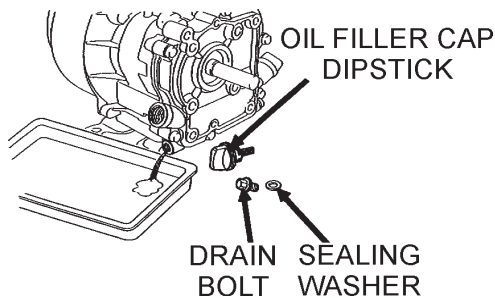

Figure 14. Engine Oil (Draining)

DANGER

DO NOT use gasoline as a cleaning solvent, because that would create a risk of fire or explosion.

ENGINE AIR CLEANER

1. Loosen the wing nut and detach the cover of the air cleaner shown in Figure 15.
2. Tap the element (Figure 15) several times on a hard surface to remove dirt, or blow compressed air [not exceeding 30 psi (207 kPa, 2.1 kgf/cm²)] through the element side. **NEVER** wash the element with detergent because the element is oil-soaked type. Replace the element when the output decreases or bad exhaust color is noticed.

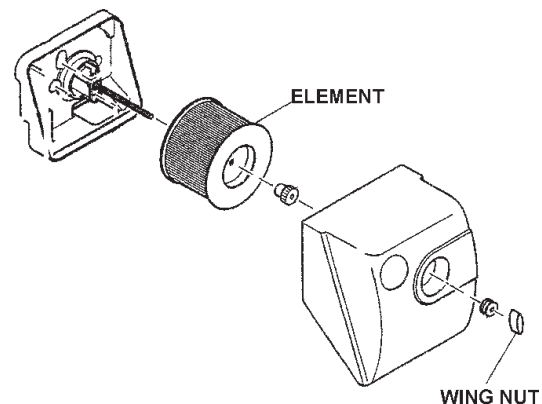

Figure 15. Engine Air Cleaner

PREPARATION FOR LONG-TERM STORAGE

Pump Storage

For storage of the pump for over 30 days, the following is required:

- Drain the fuel tank completely.
- Run the engine for about 3 minutes and then stop.
- Stop the engine. Drain the engine crankcase oil while the engine is still warm. Fill engine crankcase with fresh oil.
- Pull the recoil starter grip (Figure 17) 2 or 3 times. **DO NOT** start the engine.

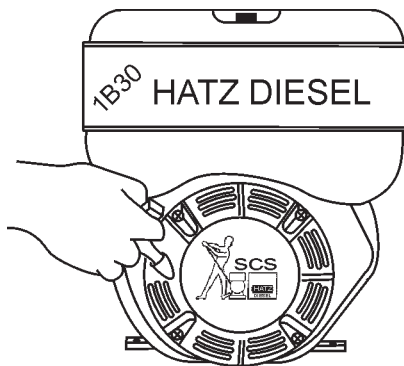

Figure 17. Recoil Starter Grip

- Pull the recoil starter grip slowly. **STOP** when it feels tight. This closes the intake and exhaust valves (compression position) , and helps prevents rust from forming.
- Wipe any oil or dirt that may have accumulated on the engine.
- Remove the drain plug from the pump and drain out any water left in the housing.
- Remove the pump cover and clean the inside of pump housing. Coat the inside of pump housing with a light film of oil to reduce corrosion. A spray can of oil works well for this application.
- Cover suction and discharge ports with duct tape to prevent any foreign matter from falling into pump.
- Cover pump and engine with plastic covering or equivalent and store in a clean, dry place.
- To protect the water cooled-seals, place one-half pint of lubricating oil (new or used) through the discharge opening on the pump and crank the engine several times. This will prevent excessive corrosion and also keep the mechanical seal lubricated.

TROUBLESHOOTING

Troubleshooting (Engine)		
Symptom	Possible Problem	Solution
Engine will not start or start is delayed, although engine can be turned over.	No Fuel reaching injection pump?	Add fuel. Check entire fuel system.
	Defective fuel pump?	Replace fuel pump.
	Fuel filter clogged?	Replace fuel filter and clean tank.
	Faulty fuel supply line?	Replace or repair fuel line.
	Compression too low?	Check piston, cylinder and valves. Adjust or repair per engine repair manual.
	Fuel pump not working correctly?	Repair or replace fuel pump.
	Oil pressure too low?	Check engine oil pressure.
	Low starting temperature limit exceeded?	Comply with cold starting instructions and proper oil viscosity.
	Defective battery?	Charge or replace battery.
	Air or water mixed in fuel system?	Check carefully for loosened fuel line coupling, loose cap nut, etc.
At low temperatures engine will not start.	Engine oil too thick?	Refill engine crankcase with correct type of oil for winter environment.
	Defective battery?	Replace battery.
Engine fires but stops soon as starter is switched off.	Fuel filter blocked?	Replace fuel filter.
	Fuel supply blocked?	Check the entire fuel system.
	Defective fuel pump?	Replace fuel pump.
Engine stops by itself during normal operation.	Fuel tank empty?	Add fuel.
	Fuel filter blocked?	Replace fuel filter.
	Defective fuel pump?	Replace fuel pump.
	Mechanical oil pressure shutdown sensor stops the engine due to low oil?	Add oil. Replace low oil shutdown sensor if necessary.
Low engine power, output and speed.	Fuel tank empty?	Replace fuel filter.
	Fuel filter clogged?	Replace fuel filter.
	Fuel tank venting is inadequate?	Ensure that tank is adequately vented.
	Leaks at pipe unions?	Check threaded pipe unions tape and tighten unions as required.
	Speed control lever does not remain in selected position?	See engine manual for corrective action.
	Engine oil level too full?	Correct engine oil level.
	Injection pump wear?	Use No. 2-D diesel fuel only. Check the fuel injection pump element and delivery valve assembly and replace as necessary.

TROUBLESHOOTING

Troubleshooting (Engine) - continued		
Symptom	Possible Problem	Solution
Low engine power output and low speed, black exhaust smoke.	Air filter blocked?	Clean or replace air filter.
	Incorrect valve clearances?	Adjust valves per engine specification.
	Malfunction at injector?	See engine manual.
Engine overheats.	Too much oil in engine crankcase?	Drain off engine oil down to uppermark on dipstick.
	Entire cooling air system contaminated/ blocked?	Clean cooling air system and cooling fin areas.
	Fan belt broken or elongated?	Change belt or adjust belt tension.
	Coolant insufficient?	Replenish coolant.
	Radiator net or radiator fin clogged with dust?	Clean net or fin carefully.
	Fan, radiator, or radiator cap defective?	Replace defective part.
	Thermostat defective?	Check thermostat and replace if necessary.
Head gasket defective or water leakage?	Replace parts.	
Troubleshooting (Trash Pump)		
Symptom	Possible Problem	Solution
Pump does not take on water.	Not enough priming water in the housing?	Add water.
	Engine speed too low?	Increase throttle.
	Strainer plugged?	Clean strainer.
	Suction hose damaged?	Replace or repair hose, and clamps.
	Air leak at suction port?	Check that fittings are tight and properly sealed.
	Pump is located too high above water line?	Move pump closer to water.
	Debris collecting in pump housing?	Clean pump housing.
	Too much distance between impeller and volute?	Adjust clearance by adding shims or replace impeller. Min. .006 inch - Max. .020 inch
	Water leaking out weep hole between pump and engine?	Check condition of mechanical seal and gaskets, between pump end and engine housing.
Pump takes in water, little or no discharge.	Engine speed too low?	Increase throttle speed.
	Suction strainer partially plugged?	Clean strainer.
	Impeller/Volute worn?	Adjust clearance by adding shims or replace impeller/volute.
Suction hose leaks at inlet.	Fittings/clamps are not sealed properly?	Tighten, replace or add clamp. (Keep extra seals on pump).
	Hose diameter is too large?	Use smaller diameter hose or replace hose.
Discharge does not stay on coupling.	Pressure too high?	Check pressure, add additional clamp.
	Hose kinked or end blocked?	Check hose.
Impeller does not turn, pump is hard to start.	Impeller jammed or blocked?	Open pump cover and clean dirt and debris from inside housing.
	Impeller and volute binding?	Adjust clearance by removing shim from behind impeller.
	Defective engine?	See Engine Owner's Manual.

EXPLANATION OF CODE IN REMARKS COLUMN

The following section explains the different symbols and remarks used in the Parts section of this manual. Use the help numbers found on the back page of the manual if there are any questions.

NOTICE

The contents and part numbers listed in the parts section are subject to change **without notice**. Multiquip does not guarantee the availability of the parts listed.

SAMPLE PARTS LIST

NO.	PART NO.	PART NAME	QTY.	REMARKS
1	12345	BOLT.....	1	INCLUDES ITEMS W/%
2%		WASHER, 1/4 IN.....		NOT SOLD SEPARATELY
2%	12347	WASHER, 3/8 IN....	1	MQ-45T ONLY
3	12348	HOSE	A/R	MAKE LOCALLY
4	12349	BEARING	1	S/N 2345B AND ABOVE

NO. Column

Unique Symbols — All items with same unique symbol

(@, #, +, %, or >) in the number column belong to the same assembly or kit, which is indicated by a note in the “Remarks” column.

Duplicate Item Numbers — Duplicate numbers indicate multiple part numbers, which are in effect for the same general item, such as different size saw blade guards in use or a part that has been updated on newer versions of the same machine.

NOTICE

When ordering a part that has more than one item number listed, check the remarks column for help in determining the proper part to order.

PART NO. Column

Numbers Used — Part numbers can be indicated by a number, a blank entry, or TBD.

TBD (To Be Determined) is generally used to show a part that has not been assigned a formal part number at the time of publication.

A blank entry generally indicates that the item is not sold separately or is not sold by Multiquip. Other entries will be clarified in the “Remarks” Column.

QTY. Column

Numbers Used — Item quantity can be indicated by a number, a blank entry, or A/R.

A/R (As Required) is generally used for hoses or other parts that are sold in bulk and cut to length.

A blank entry generally indicates that the item is not sold separately. Other entries will be clarified in the “Remarks” Column.

REMARKS Column

Some of the most common notes found in the “Remarks” Column are listed below. Other additional notes needed to describe the item can also be shown.

Assembly/Kit — All items on the parts list with the same unique symbol will be included when this item is purchased.

Indicated by:

“INCLUDES ITEMS W/(unique symbol)”

Serial Number Break — Used to list an effective serial number range where a particular part is used.

Indicated by:

“S/N XXXXX AND BELOW”

“S/N XXXX AND ABOVE”

“S/N XXXX TO S/N XXX”

Specific Model Number Use — Indicates that the part is used only with the specific model number or model number variant listed. It can also be used to show a part is NOT used on a specific model or model number variant.

Indicated by:

“XXXXX ONLY”

“NOT USED ON XXXX”

“Make/Obtain Locally” — Indicates that the part can be purchased at any hardware shop or made out of available items. Examples include battery cables, shims, and certain washers and nuts.

“Not Sold Separately” — Indicates that an item cannot be purchased as a separate item and is either part of an assembly/kit that can be purchased, or is not available for sale through Multiquip.

SUGGESTED SPARE PARTS

QP3TZTRASH PUMP 1 TO 3 UNITS W/ 1B30

Qty.	P/N	Description
2	KIT3T	KIT, MECHANICAL SEAL, O-RINGS
1	2367040032	IMPELLER, S/N 0381 AND BELOW
1	2367040031	IMPELLER, S/N 0382 AND ABOVE
4	0631211159	FLOODING CAP, W/ O-RING
3	50426000	ELEMENT, AIR CLEANER
1	05088901	ROPE STARTER
1	01535302	CAP, FUEL TANK
3	01635200	FUEL FILTER, GAS TANK
3	50404900	KEY, STARTER
1	510229	THROTTLE CABLE

NOTICE

Part number on this Suggested Spare Parts List may supersede/replace the P/N shown in the text pages of this manual.

PUMP ASSY.

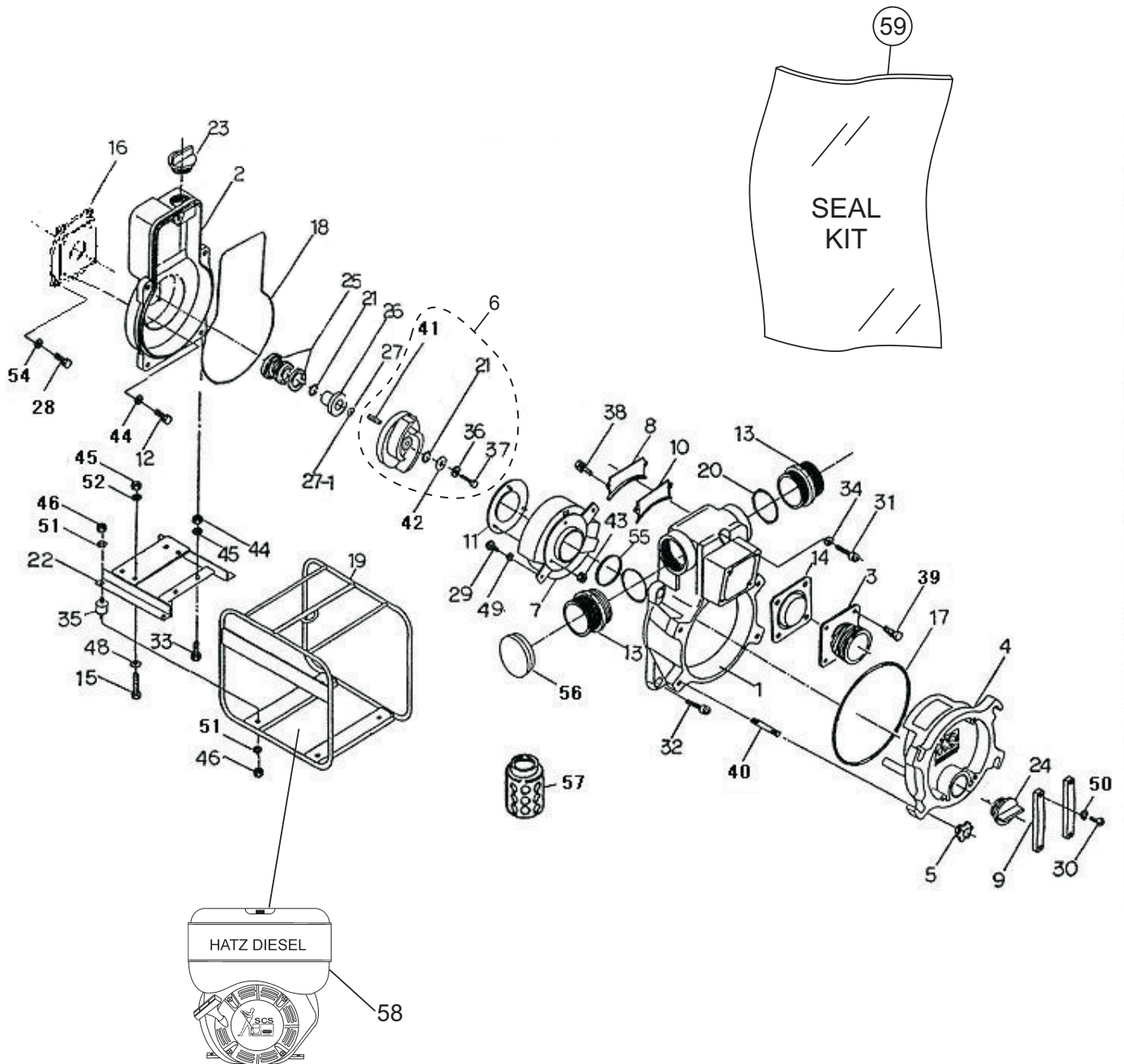

PUMP ASSY.

PUMP ASSY.

<u>NO.</u>	<u>PART NO.</u>	<u>PART NAME</u>	<u>QTY.</u>	<u>REMARKS</u>
1	1992100011	CASING	1	
2	1992100020	CASING COVER	1	
3	13910001600014	SUCTION COVER	1	
4	1992100173	DRAIN COVER	1	
5	19920002200014	DRAIN COVER KNOB	4	
6	2368040033ASSY	IMPELLER KIT	1	INCLUDES ITEMS W/#
7	1992000133	VOLUTE CASING, 2-POST	1	OLDER STYLE VOLUTE WILL CROSS TO 3T4PKIT
7	1992000110	VOLUTE CASING, 4-POST	1	NEW STYLE 4-POST
8	1992100742	SUCTION PLATE	1	
9	1247100250	DRAIN COVER SET HANDLE	2	
10	1992330410	SUCTION PLATE PACKING	1	
11	1992250700	WEAR PLATE	1	
12	0105090820	BOLT (CASING COVER), M8 x 20	4	
13	07904330300014	NIPPLE, NPS3" X NPT3"	2	
14	1378350350	CHECK VALVE	1	
15	0105090825	BOLT(ENGINE), M8 X 25	4	
16	43130006000014	CASING COVER SET PLATE	1	
17@	0483602250	O-RING (DRAIN COVER)	1	
18	0489403400	O-RING (CASING), 4 X 340 MM	1	
19	2367214010P002	BASE, SS400	1	
20	0481310800	O-RING (NIPPLE)	2	
21@#	0482200240	O-RING, IMPELLER, MECH SEAL	2	SEE NOTICE BELOW
22	23672140200014	ENGINE BASE,SS400	1	
23	0631211159	FLOODING CAP, PF1 1/2" W/ O-RING	1	
24	0631211159	DRAIN CAP, PF1 1/2" W/ O-RING	1	
25@	0803442930	MECHANICAL SEAL	1	
26@	0811885446	MECHANICAL SEAL SLEEVE, DIA. 30MM	1	
27@	0852834525	ADJUST LINER, 45 x 25.4 MM T0.3	1	
27-1@	0852854525	ADJUST LINER, 45 x25.4 MM T0.5	1	
28	0105091025	BOLT(CASING COVER SET PLATE) M10 X 25	4	
29	0131190823	CAP SCREW (VOLUTE CASING), M8 X 20	4	
30	0141090825	SCREW (DRAIN COVER SET HANDLE),M8 X 25	4	
31	0131191290	CAP SCREW (CASING), M12 X90	1	
32	0131191235	CAP SCREW (CASING), M12 X 35	4	
33	0105091040	BOLT (PUMP),M10 X 40	2	
34	0459220120	SEAL WASHER(CASING), M12	1	
35	0723302040	CUSHION RUBBER 40 X 20 MM M10	4	
36#	0458220100	SEAL WASHER, IMPELLER	1	
37#	0191190750	BOLT, IMPELLER	1	

NOTICE

ITEM 21, O-RING, IS INCLUDED IN IMPELLER KIT, ITEM 6. WHEN ORDERED AS PART OF THE KIT, QUANTITY OF O-RING IS ONE. REPLACEMENT OF IMPELLER REQUIRES TWO O-RINGS, SO IT IS NECESSARY TO ORDER ONE ADDITIONAL O-RING.

PUMP ASSY.

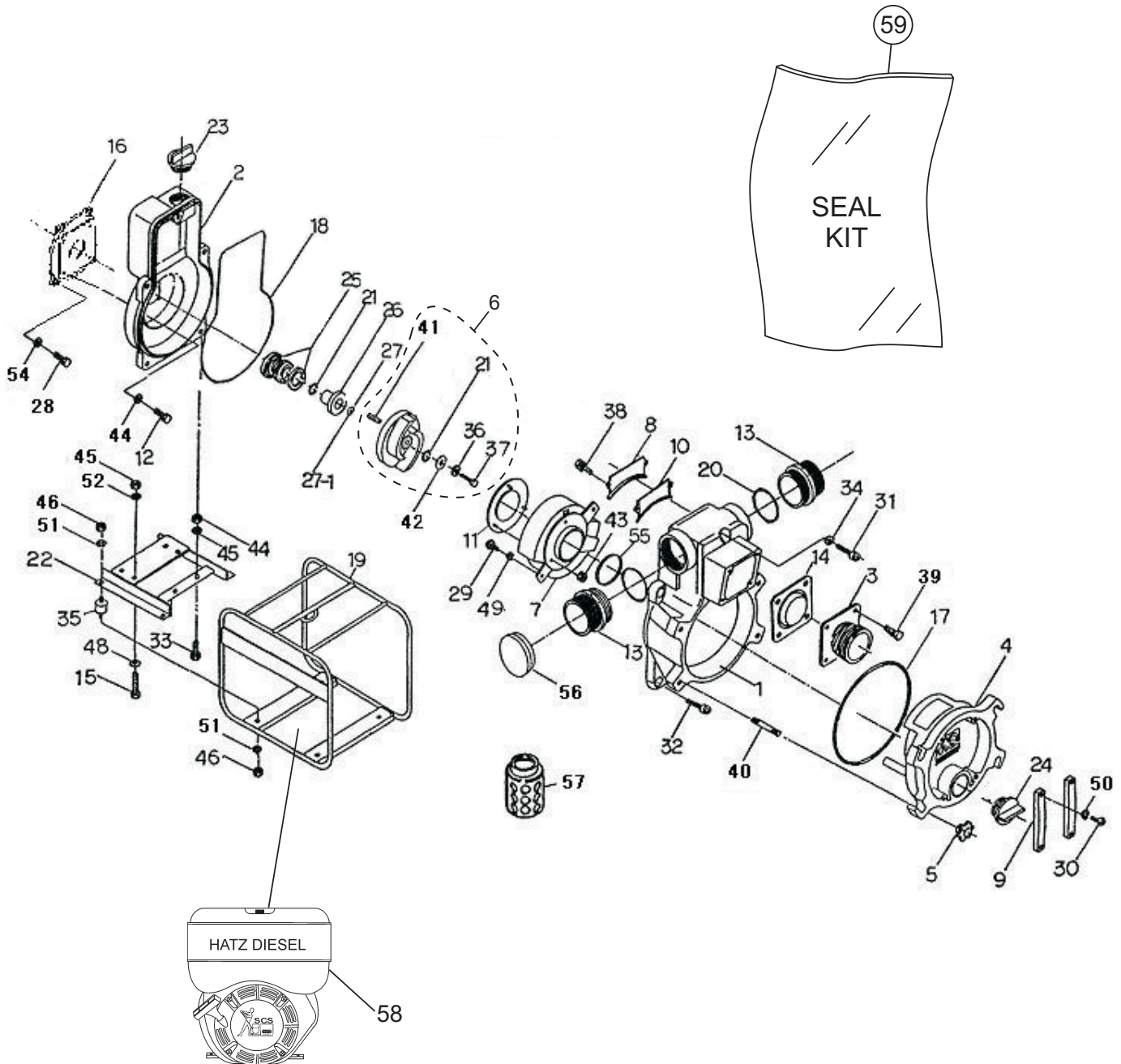

PUMP ASSY.

PUMP ASSY. (cont.)

<u>NO.</u>	<u>PART NO.</u>	<u>PART NAME</u>	<u>QTY.</u>	<u>REMARKS</u>
38	0181090820	BOLT SET W/ SPRING WASHER (SUCTION PLATE) M8 X 20	2	
39	0181090825	BOLT SET W/ SPRING WASHER (SUCTION COVER) M8 X 25	4	
40	0151191257	STUD BOLT (DRAIN COVER HANDLE)	4	
41#	0520040431	KEY, IMPELLER	1	
42	43342012400011	IMPELLER WASHER 42 X 12 MM T4.5	1	
43	0204490060	U-NUT WEAR PLATE, M6	3	
44	0458220080	SEAL WASHER (CASING COVER), M8	4	
45	0205490080	NUT (ENGINE), M8	4	
46	0205490100	NUT (CUSHION RUBBER), M10	8	
47	0205490100	NUT (PUMP), M10	2	
48	0401650100	WASHER (ENGINE), M8	4	
49	0451290080	SPRING WASHER (VOLUTE CASING), M8	4	
50	0451290080	SPRING WASHER (DRAIN COVER SET HANDLE), M8	4	
51	0451290100	SPRING WASHER (CUSHION RUBBER), M10	8	
52	0451290080	SPRING WASHER (ENGINE), M8	4	
53	0451290100	SPRING WASHER (PUMP), M10	2	
54	0451290100	SPRING WASHER (CASING COVER SETPLATE), M10	4	
55	0480570850	O-RING (VOLUTE CASING)	1	
56	1992108050	CAP	1	
57	0742214080	STRAINER	1	
58	1B30	ENGINE, HATZ	1	
59	KIT3T	KIT, MECHANICAL SEAL, SLEEVE, & O-RINGS	1	INCLUDES ITEMS W/@

SPARE PARTS KITS ASSY.

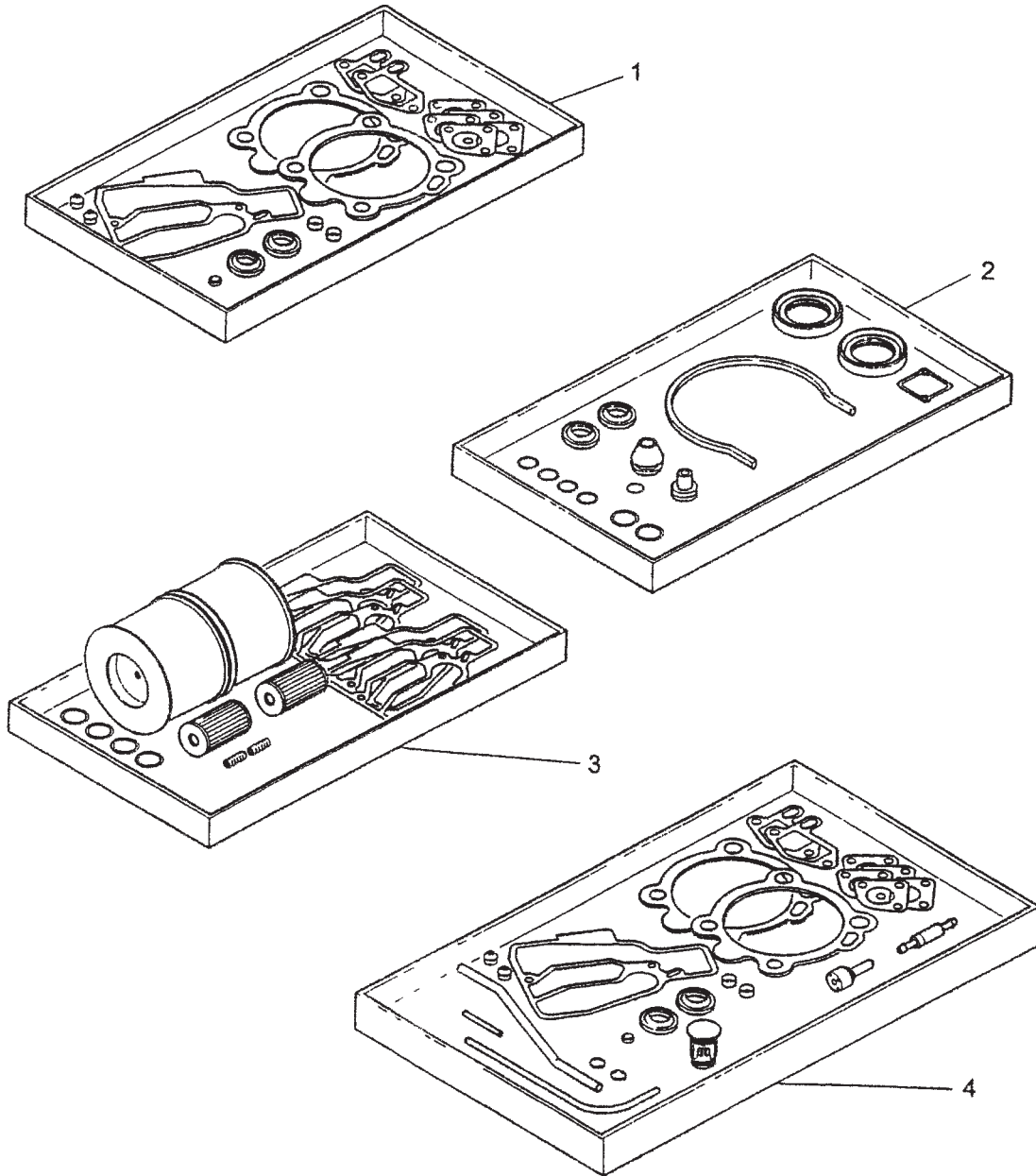

SPARE PARTS KITS ASSY.

SPARE PARTS KITS ASSY.

<u>NO.</u>	<u>PART NO.</u>	<u>PART NAME</u>	<u>QTY.</u>	<u>REMARKS</u>
1	01582200	GASKET SET CYL. HEAD	1	
2	01582300	GASKET SET CRANKCASE	1	
3	01582400	MAINTENANCE KIT- 1000 HRS	1	
4	01582500	EMERGENCY KIT	1	

ACCESSORIES ASSY.

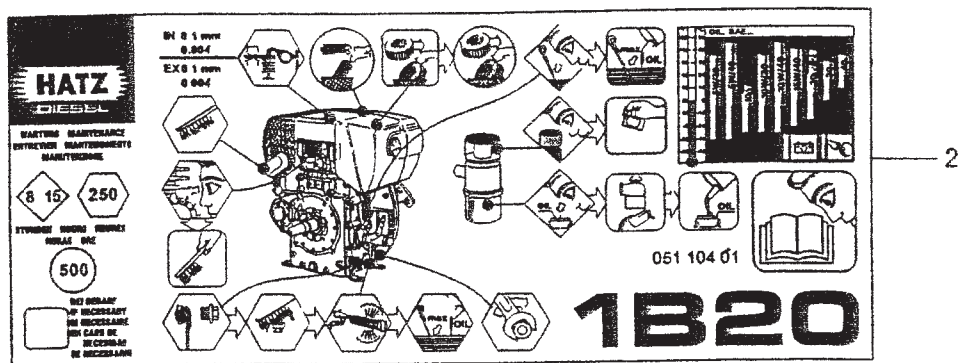
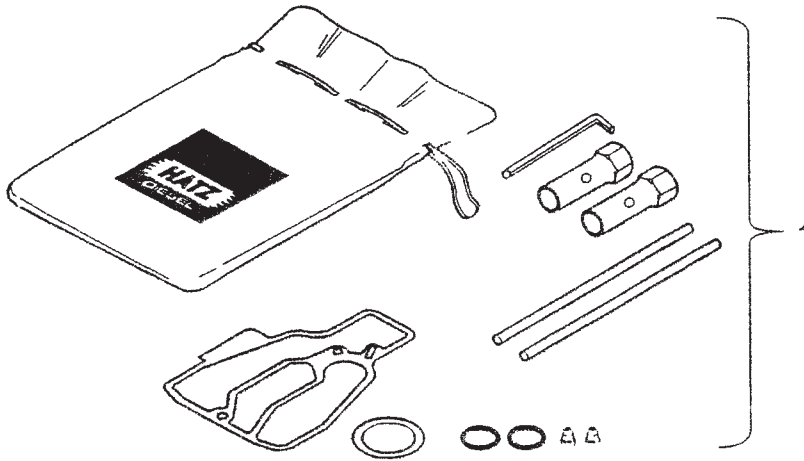

ACCESSORIES ASSY.

ACCESSORIES ASSY.

<u>NO.</u>	<u>PART NO.</u>	<u>PART NAME</u>	<u>QTY.</u>	<u>REMARKS</u>
1	01578700	TOOL KIT	1	
2	05120100	DECAL MAINTENANCE	1	
3	05130000	DECAL START	1	
4	05130100	DECAL	1	

CRANKCASE AND ENGINE MOUNT ASSY.

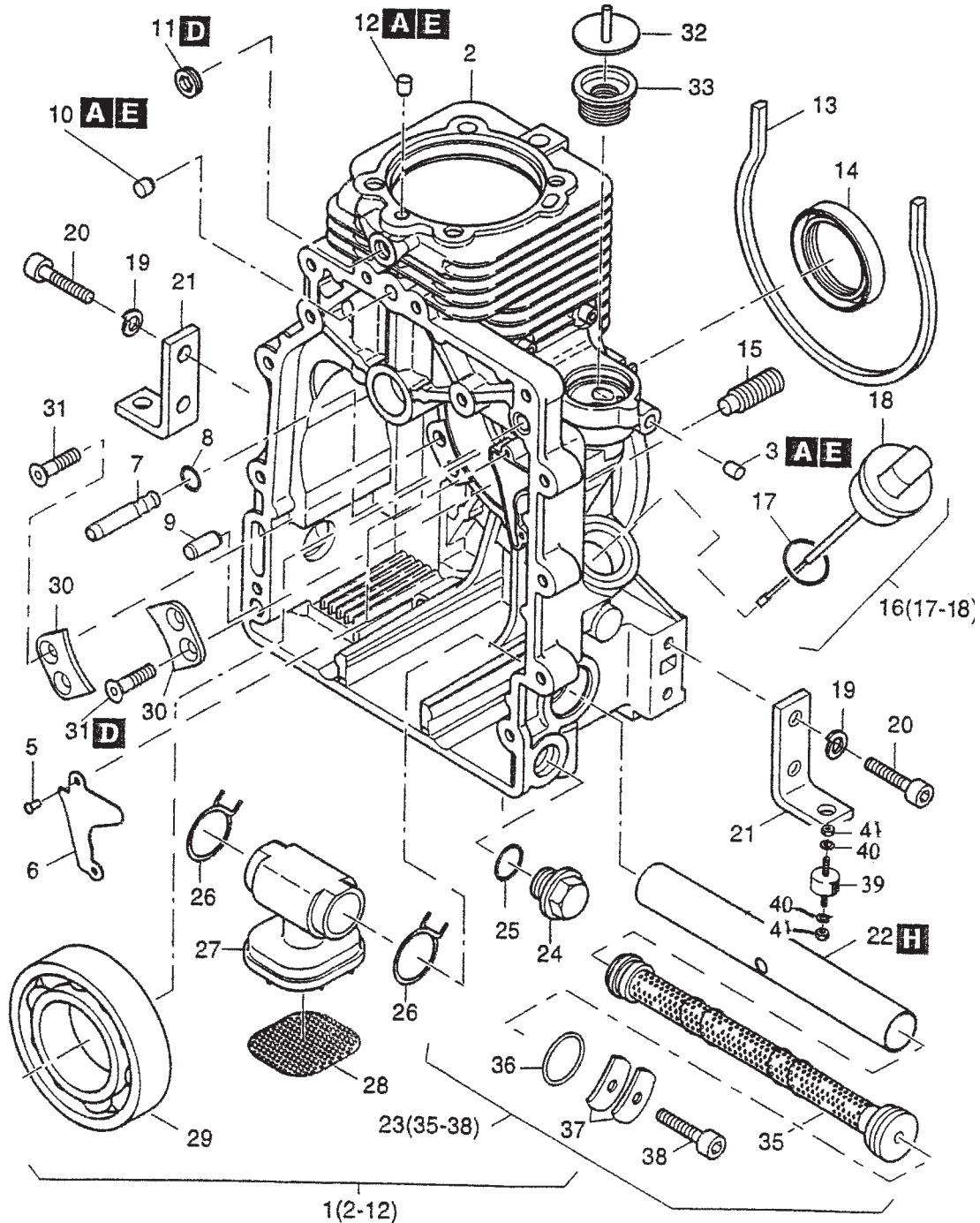

NOTE: Refer to Table 9 at the end of the manual for *letter* (A to L) call-outs.

CRANKCASE AND ENGINE MOUNT ASSY.

CRANKCASE AND ENGINE MOUNT ASSY.

<u>NO.</u>	<u>PART NO.</u>	<u>PART NAME</u>	<u>QTY.</u>	<u>REMARKS</u>
1	01582710	CRANKCASE ASSEMBLY	1	INCLUDES ITEMS W/ *
2*		CRANKCASE	1	NOT SOLD SEPARATELY
3*	03455000	PLUG 6.5X7	1	
5*	40002600	BLIND RIVET	2	
6*	01333100	COVER PLATE	1	
8*	50440300	O- RING	1	INCLUDED IN CRANKC. GASK. SET
9*	50249101	CYL. PIN	1	
10*	04123800	PLUG	1	
11*	50062300	SCREW M10X1	1	
12*	04112800	PLUG	1	
13	04112600	SEALING STRIP 419MM	1	INCLUDED IN CRANKC.GASK. SET
14	50449800	OIL SEAL 42X55X10	1	INCLUDED IN CRANKC. GASK. SET
15	04115200	GRUB SCREW	1	
16	01316000	DIPSTICK W/SEALING RING	1	INCLUDES ITEMS W/ %
17%	04125000	SEALING RING	1	
18%		DIPSTICK.....	1	NOT SOLD SEPARATELY
19	50208500	SPRING WASHER	8	
20	04121900	ALL. SCREW M8X35	8	
21	04099302	ENGINE BRACKET	4	
22	04105710	TUBE F. OIL FILTER	1	
23	01542702	OIL SUCTION FILTER	1	INCLUDES ITEMS W/#
24	50373100	DRAIN PLUG M22X1.5	1	INCLUDED IN MAINTENANCE KIT
25	50469800	JOINT A22X27	1	INCLUDED IN CRANKC. GASK. SET AND MAINTENANCE KIT
26	05036900	HOSE CLIP	2	
27	04104400	SUCTION PORT	1	
28	04104500	SIEVE	1	
29	50449700	BALL BEARING 6309	1	
30	04094400	PLATE	2	
31	50328000	CENTER SUNK SCREW AM6X16	4	
32	01555800	COVER	1	
33	03568700	RUBBER DIAPHRAGM	1	
35#		FILTER, OIL SUCTION	1	NOT SOLD SEPARATELY
36#	50475900	O- RING 20X4	1	
37#	05148200	PLATE SPRING	2	
38#	50170700	ALL. SCREW M6X16	1	
39	99400696	ISOLATOR	4	
40	50208500	SPRING WASHER	8	
41	50022900	NUT M8	8	

CRANKSHAFT ASSY.

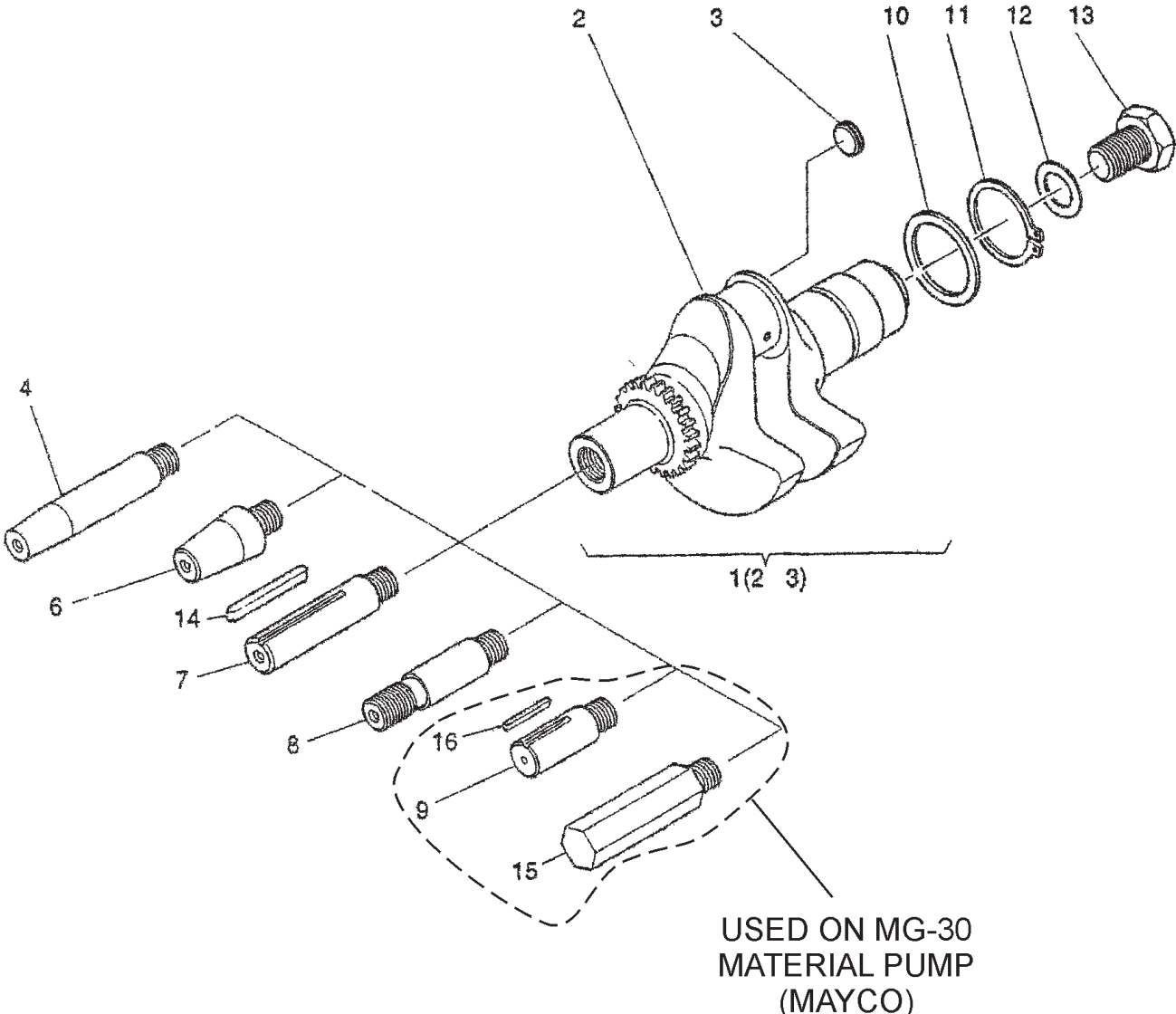

CRANKSHAFT ASSY.

CRANKSHAFT ASSY.

<u>NO.</u>	<u>PART NO.</u>	<u>PART NAME</u>	<u>QTY.</u>	<u>REMARKS</u>
1	01334200	CRANKSHAFT NO. X W? PLUG	1	INCLUDES ITEMS W/*
2*		CRANKSHAFT	1	NOT SOLD SEPARATELY
3*	04125300	CLOSING PLUG 12 MM	1	
4	05127401	STUBSHAFT NO. 4 SAE GEN	1	
6	05142700	STUBSHAFT TAP 25 DIA.	1	
7	05127600	STUBSHAFT NO. 2 1" DIA.	1	
8	05127700	STUBSHAFT NO. 1 1" DIA.	1	
9	05127801	STUBSHAFT 25 DIA.	1	
10	40065600	SUPPORTING DISK 45X55X3.0	1	
11	50021600	CIRCLIP A45X1.75	1	
12	04114201	DISK 18.5X37X5	1	
13	50443600	HEX. SCREW M18X1.5X55	1	
14	05141600	FITTING KEY A6.3 5X61	1	
15	05107301	STUBSHAFT SEM FINISHED 27 MM DIA.	1	
16	50473700	FITTING KEY 7X8X45	1	

CAMSHAFT ASSY.

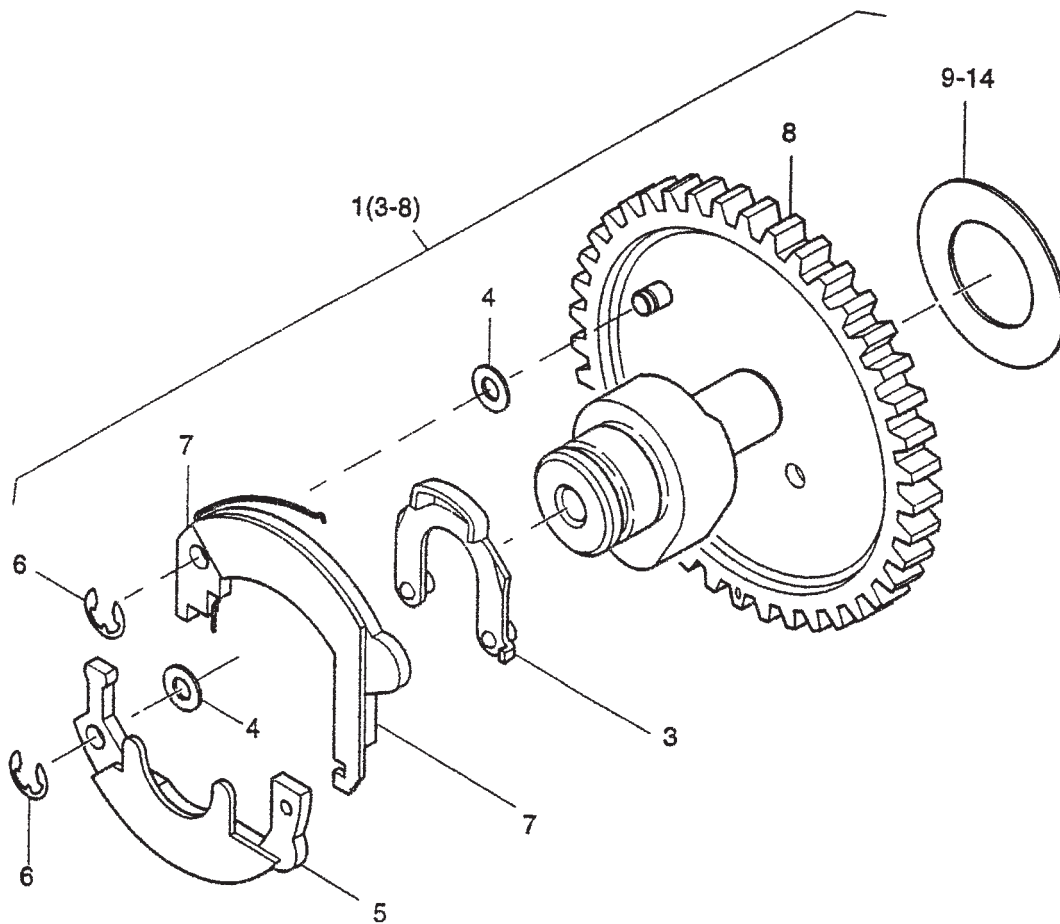

CAMSHAFT ASSY.

CAMSHAFT ASSY.

<u>NO.</u>	<u>PART NO.</u>	<u>PART NAME</u>	<u>QTY.</u>	<u>REMARKS</u>
1	01503520	CAMSHAFT ASSY.	1	INCLUDES ITEMS W/*
3*	01326400	CAMLEVER	1	
4*	50123200	SHIM 5X10X0.5 DIN988	2	
5*	01326600	FLYWEIGHT	1	
6*	50255300	LOCK WASHER	2	
7*	01326500	FLYWEIGHT	1	
8*		CAMSHAFT	1	NOT SOLD SEPARATELY
9	04121700	WASHER 0.9MM 23X38X0.9	1	
10	04112100	WASHER 1.0MM 23X38X1.0	1	
11	04112200	WASHER 1.1MM 23X38X1.1	1	
12	04112300	WASHER 1.2MM 23X38X1.2	1	
13	04125100	WASHER 1.3MM 23X38X1.3	1	
14	04125200	WASHER 1.4MM 23X38X1.4	1	

PISTON ASSY.

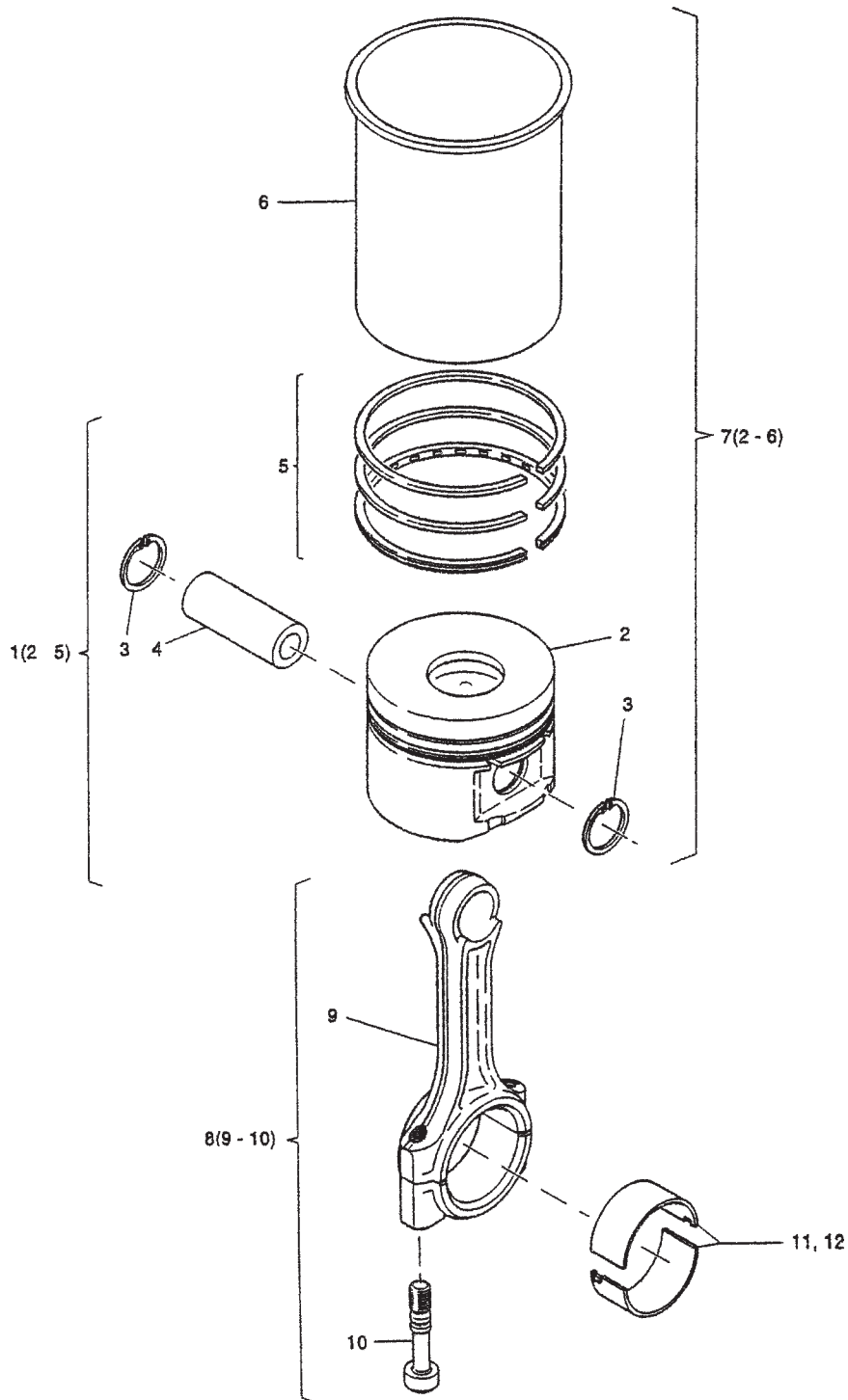

PISTON ASSY.

PISTON ASSY.

<u>NO.</u>	<u>PART NO.</u>	<u>PART NAME</u>	<u>QTY.</u>	<u>REMARKS</u>
1	01328501	PISTON 80MM ASSY.	1	INCLUDES ITEMS W/*
2*%		PISTON 80MM	1	NOT SOLD SEPARATELY
3*%	50464000	CIRCLIP	2	
4*%	50463600	PISTON PIN	1	
5*%	01328601	PISTON RING SET 80MM	1	
6%		CYLINDER	1	NOT SOLD SEPARATELY
7	01582600	CYLINDER WITH PISTON ASSY.	1	INCLUDES ITEMS W/%
8	01329201	CONROD ASSY.	1	INCLUDES ITEMS W/\$
9\$		CONROD	1	NOT SOLD SEPARATELY
10\$	04113100	CONROD SCREW	2	
11	01582100	BIG END BEARING	1	
12	01582000	BIG END BEARING - 0.5MM	1	

CYLINDER HEAD ASSY.

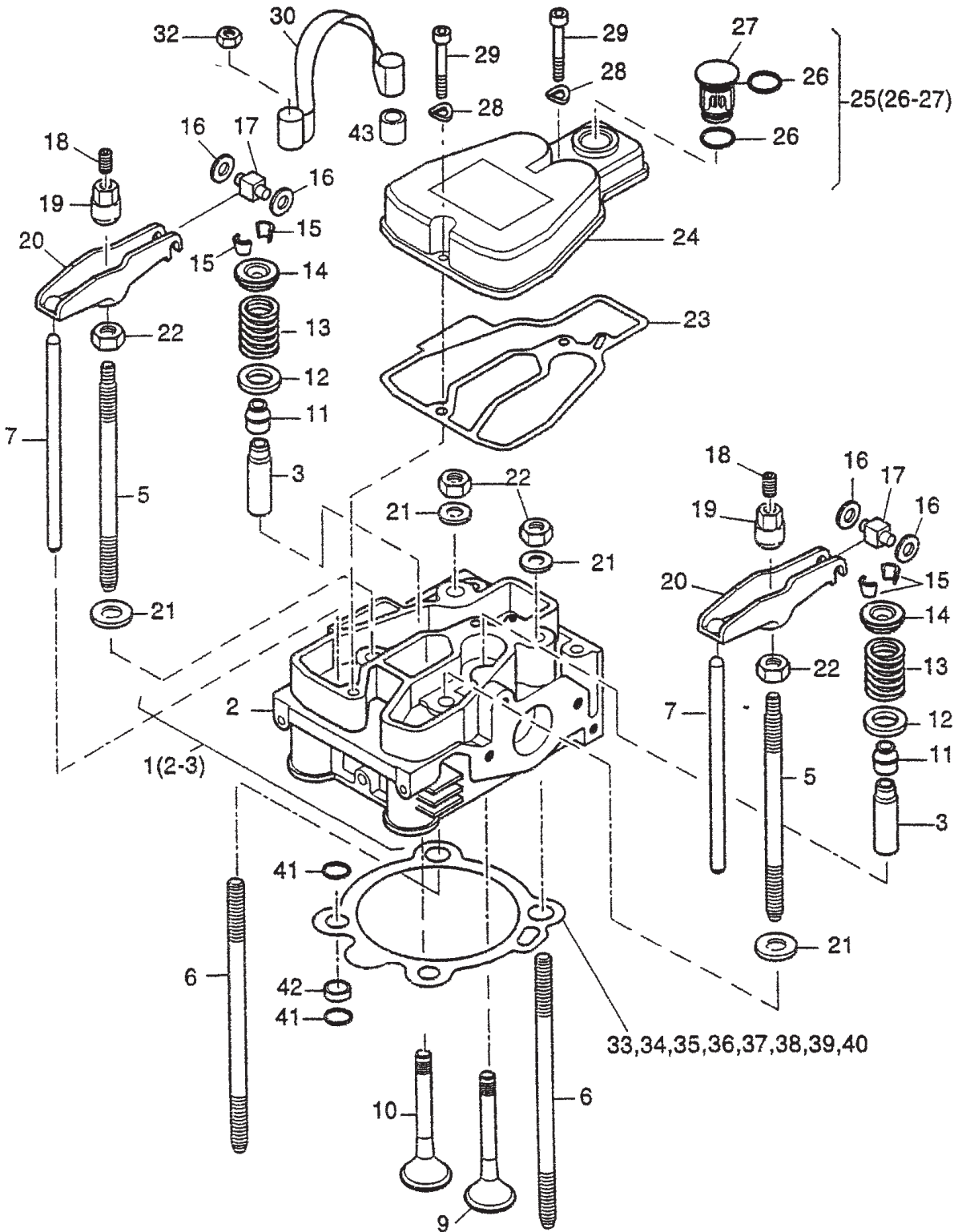

CYLINDER HEAD ASSY.

CYLINDER HEAD ASSY.

NO.	PART NO.	PART NAME	QTY.	REMARKS
1	01529801	CYLINDER HEAD ASSY	1	INCLUDES ITEMS W/*
2*		CYLINDER HEAD	1	NOT SOLD SEPARATELY
3*	05129500	VALVE GUIDE	2	
5	05097500	STUD CYLINDER HEAD 141MM	2	
6	05097400	STUD CYLINDER HEAD 148MM	2	
7	05098900	PUSH ROD	2	
9	05093000	VALVE, INTAKE	1	
10	05093100	VALVE, EXHAUST	1	
11	50425800	VALVE STEM SEAL CAP	2	INCLUDED IN CRANKC. GASK. SET
12	04093700	WASHER	2	
13	04113500	VALVE SPRING	2	
14	04093800	SPRING PLATE	2	
15	50425700	COLLET	2	
16	50445100	DISK 6X12X1.2 DIN 988	4	
17	05091101	SLIDER	2	
18	50358000	GRUB SCREW M8X10	2	INCLUDED IN MAINTENANCE KIT
19	05054700	NUT FOR ROCKER ARM	2	
20	05098201	ROCKER	2	
21	05099300	WASHER 10.1X35X3	4	
22	50396600	HEX. NUT M10 DIN 934	4	
23	05093301	HEAD COVER GASKET	1	INCLUDED IN CRANKC. GASK. SET AND MAINTENANCE KIT
24	05092701	CYLINDER HEAD COVER	1	
25	01509600	DOSING DEVICE ASSY	1	INCLUDES ITEMS W/+ INCLUDED IN EMERGENCY KIT
26+	50425900	O- RING 16X2	2	
27+		DOSING DEVICE	1	NOT SOLD SEPARATELY
28	50081200	SPRING WASHER A6	2	
29	50374900	ALL SCREW M6X35	2	
30	04117701	LIFTING STRAP	1	
32	50453200	HEX. NUT M10	2	
33	05096301	CYLINDER HEAD GASKET 0.3MM	0..1	
34	05096401	CYLINDER HEAD GASKET 0.4MM	0..1	INCLUDED IN HEAD GASKET SET
35	05096501	CYLINDER HEAD GASKET 0.5MM	0..1	INCLUDED IN HEAD GASKET SET
36	05096601	CYLINDER HEAD GASKET 0.6MM	0..1	
37	05096701	CYLINDER HEAD GASKET 0.7MM	0..1	
38	05096801	CYLINDER HEAD GASKET 0.8MM	0..1	
39	05096901	CYLINDER HEAD GASKET 0.9MM	0..1	
40	05097001	CYLINDER HEAD GASKET 1.0MM	0..1	
41	50440300	O- RING 8X1.5	4	INCLUDED IN HEAD GASKET SET
42	04133500	SEALING RING CYLINDER HEAD	2	INCLUDED IN HEAD GASKET SET
43	04126100	PROTECTION HOSE 10X12X9	2	

OIL PUMP/GOVERNOR ASSY.

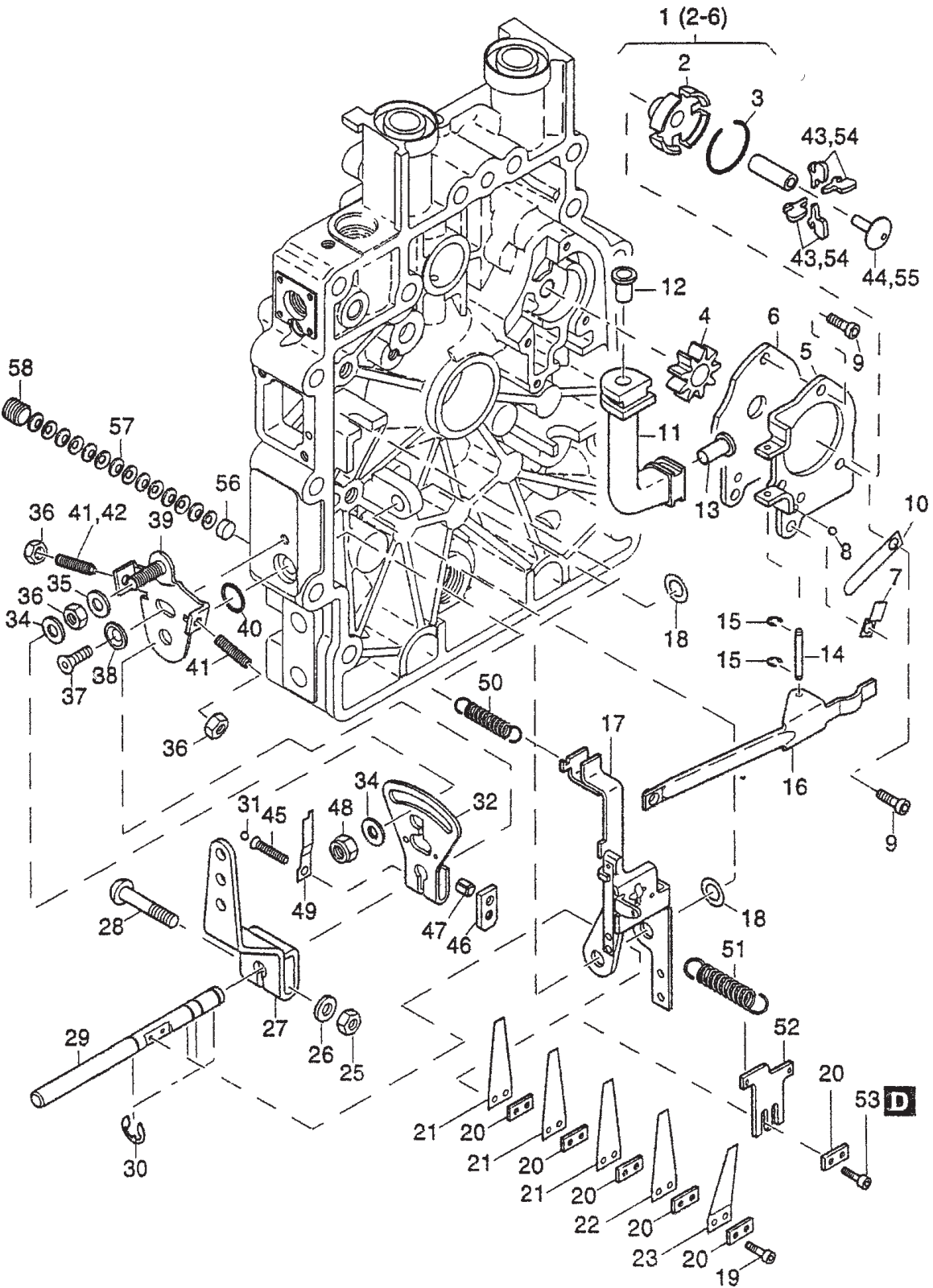

NOTE: Refer to Table 9 at the end of the manual for *letter* (A to L) call-outs.

OIL PUMP/GOVERNOR ASSY.

OIL PUMP/GOVERNOR

<u>NO.</u>	<u>PART NO.</u>	<u>PART NAME</u>	<u>QTY.</u>	<u>REMARKS</u>
1	01530210	COVER OIL PUMP ASSY.	1	INCLUDES ITEMS W/*
2*		COVER, OIL PUMP	1	NOT SOLD SEPARATELY
3*	50434901	CIRCLIP	1	
4*		GEAR, OIL PUMP	1	NOT SOLD SEPARATELY
5*		HOUSING, OIL PUMP	1	NOT SOLD SEPARATELY
6*		HOUSING, OIL PUMP	1	NOT SOLD SEPARATELY
7	05097100	RETAINING STRAP	1	
8	50447900	BALL 3.5MM	1	
9	50429400	ALL. SCREW M5X12	4	
10	05097300	FLAT SPRING 0.4	1	
11	04102900	OIL SUCTION TUBE	1	
12	50447400	TUBE INSERT	1	
13	50447500	TUBE INSERT	1	
14	05078600	SHAFT	1	
15	50434800	CIRCLIP	2	
16	05079400	LEVER	1	
17	01530402	GOVERNOR LEVER	1	
18	50422400	SHIM 8X14X1	2	
18	50125800	DISK 8X14X0.5	AS REQUIRED	
19	50435000	ALL. SCREW M3X12	2	
20	05079800	INTERMED. PLATE	AS REQUIRED	
21	05131600	GOVERNOR SPRING 0.2MM	AS REQUIRED	
22	05078900	GOVERNOR SPRING 0.3	1	
23	05148600	STOP SPRING 0.4MM	1	
25	50144400	HEX. NUT M6	1	
26	50144500	FLAT WASHER	1	
27	04095600	LEVER	1	
28	03927300	SCREW M6X32	1	
29	05079301	SHAFT	1	
30	50092700	CIRCLIP	4	
31	50347100	BALL 3.175MM	1	
32	01333000	CONSOLE	1	
34	50114300	DISK	2	
35	50144500	FLAT WASHER	1	
36	50144400	HEX. NUT M6	3	
37	50423900	CTR. SUNK SCREW M6X20	1	
38	04122900	DISK	1	
39	01316402	SUPPORT	1	

OIL PUMP/GOVERNOR ASSY.

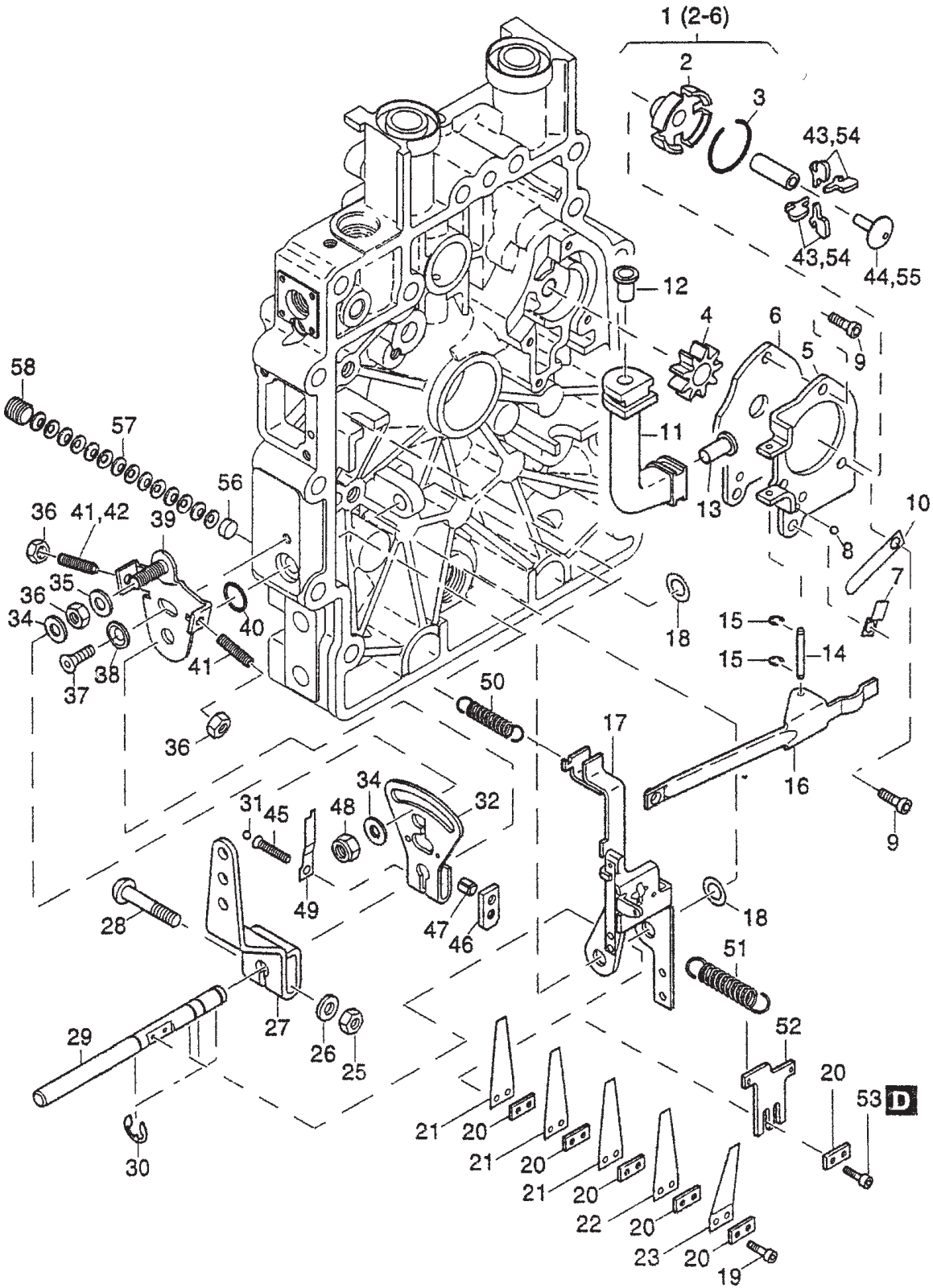

NOTE: Refer to Table 9 at the end of the manual for *letter* (A to L) call-outs.

OIL PUMP/GOVERNOR ASSY.

OIL PUMP/GOVERNOR (cont.)

<u>NO.</u>	<u>PART NO.</u>	<u>PART NAME</u>	<u>QTY.</u>	<u>REMARKS</u>
40	40022401	O- RING 8X2	1	
41	50138100	THREADED PIN M6X35	AS REQUIRED	
42	50004200	THREADED PIN M6X18	AS REQUIRED	
43	05079601	CENTRIFUGAL WEIGHT	8	
44	05078501	GOVERNOR SLEEVE	1	
45	50475300	FILL. HEAD SCREW 5X25	1	
46	05151300	SUPPORT	1	
47	50475400	PIN 5X8	1	
48	50328300	HEX. NUT M6	1	
49	04122800	PLATE SPRING	1	
50	04000200	TENSION SPRING	1	
51	05130900	GOVERNOR SPRING	1	
52	05130800	STOP PLATE	1	
53	50465300	CYL. SCREW M3X8	2	
54	05146900	CENTRIFUGAL WEIGHT	4	
55	05147001	GOVERNOR SLEEVE	1	
56	05151700	PLUG	1	
57	50475800	PLATE SPRING	14	
58	50475700	GRUB SCREW M10X10	1	

TIMING COVER ASSY.

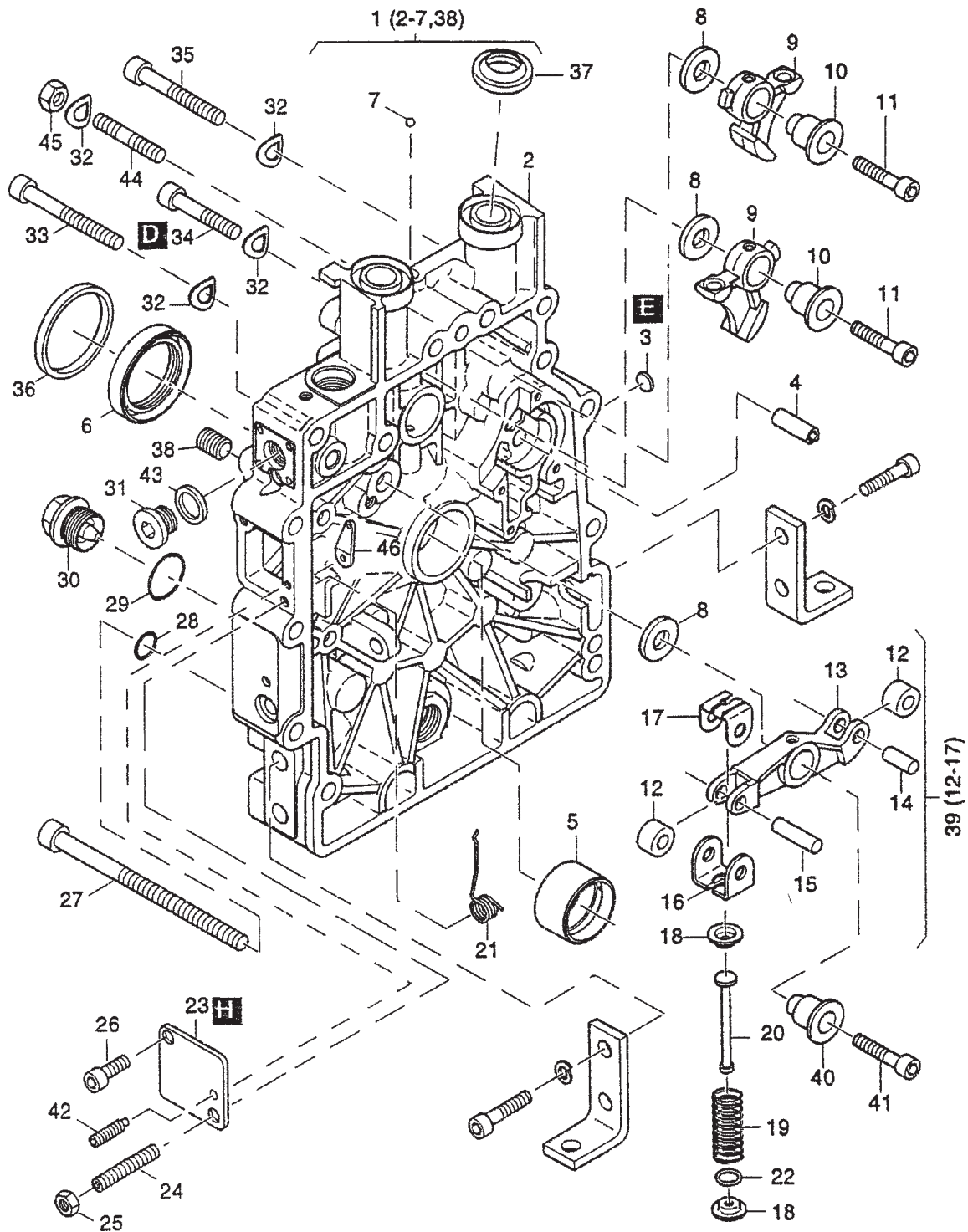

NOTE: Refer to Table 9 at the end of the manual for *letter* (A to L) call-outs.

TIMING COVER ASSY.

TIMING COVER ASSY.

<u>NO.</u>	<u>PART NO.</u>	<u>PART NAME</u>	<u>QTY.</u>	<u>REMARKS</u>
1	01319510	TIMING COVER ASSY	1	INCLUDES ITEMS W/*
2*		TIMING COVER	1	NOT SOLD SEPARATELY
3*	04130200	CLOSING PLUG	1	
4*	01533900	BOLT GOVERNOR HOUSING	1	
5*	05053100	MAIN BEARING	1	
5	04124800	MAIN BEARING - 0.5	1	
6*	40033700	OIL SEAL 30X47X8	1	IN CRANKCASE GASKET SET
7*	50443400	BALL	1	
8	03794100	WASHER	3	
9	05053400	CAM FOLLOWER	2	
10	03794201	CAM FOLLOW SPINDLE	2	
11	50457900	ALL. SCREW M6X25	2	
12\$		BUSHING, ROCKER ARM	2	NOT SOLD SEPARATELY
13\$		ROCKER ARM	1	NOT SOLD SEPARATELY
14\$		PIN, ROCKER ARM	1	NOT SOLD SEPARATELY
15\$		PIN, ROCKER ARM	1	NOT SOLD SEPARATELY
16\$		CLAMP, ROCKER ARM	1	NOT SOLD SEPARATELY
17\$		CLAMP, ROCKER ARM	1	NOT SOLD SEPARATELY
18	04094801	CUP	2	
19	04095700	PRESSURE SPRING	1	
20	04094700	DRAW ROD	1	
21	05095210	SPRING	1	
22	04133900	DISK 10.7X19X0.5	1	
23	04095210	COVER	1	
24	50448901	GRUB SCREW M6X30	1	
25	50144400	HEX. NUT M6	1	
26	50384200	ALL. SCREW M6X12	1	
27	50463000	ALL. SCREW M8X130	2	
28	50162900	JOINT A8X14	2	IN CRANKCASE GASKET SET
29	50469800	JOINT A22X27	1	IN MAINT. + CRANKCASE SET
30	50373100	DRAIN PLUG M22X1.5	1	IN MAINTENANCE KIT
31	50459200	CLOSING SCREW M12X1.5	1	
32	50095100	SPRING WASHER A8	13	
33	50248800	ALL. SCREW M8X60	1	
34	50453400	ALL. SCREW M8X45	2	
35	50392900	ALL. SCREWM8X50	9	
36	04097800	CENTERING RING SAE A	1	
37	04106500	SEALING RING TIMING COVER	2	IN HEAD GASKET SET
38*	50358000	GRUB SCREW M8X10	5	
39	01319601	ROCKER ARM	1	INCLUDES ITEMS W/\$
40	04096810	CAM FOLLOW SPINDLE	1	
41	50469900	ALL. SCREW M6X30	1	
42	50274901	GRUB SCREW M4X20	1	
43	04122000	JOINT	1	
44	50038700	STUD M8X50	1	
45	50148000	HEX. NUT M8	1	
46	05127100	LEVER	1	

FLYWHEEL ASSY.

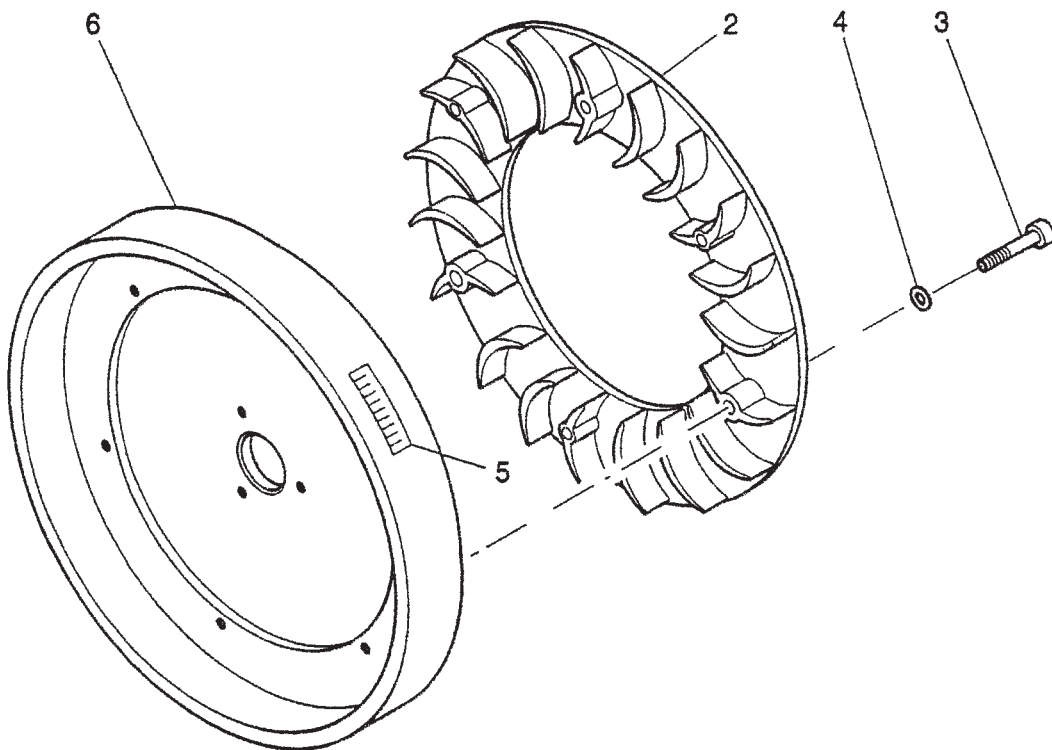

FLYWHEEL ASSY.

FLYWHEEL ASSY.

<u>NO.</u>	<u>PART NO.</u>	<u>PART NAME</u>	<u>QTY.</u>	<u>REMARKS</u>
2	01321310	BLOWER RING	1	
3	50327300	ALL. SCREW M4X20	6	
4	50003400	SPRING WASHER A4	6	
5	04117300	STICKER "TDC"	1	
6	04110302	FLYWHEEL	1	

FUEL INJECTION ASSY.

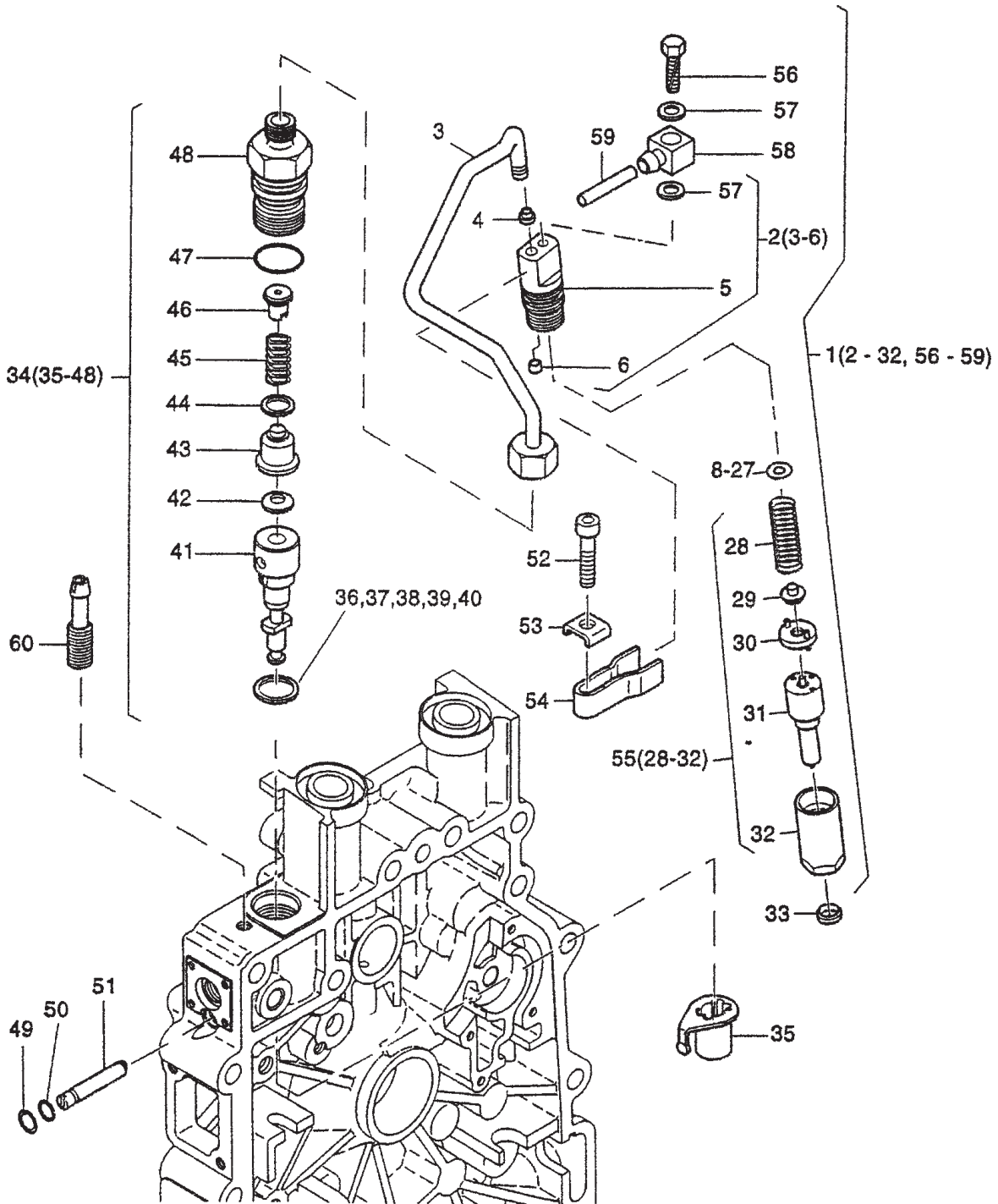

FUEL INJECTION ASSY.

FUEL INJECTION ASSY.

<u>NO.</u>	<u>PART NO.</u>	<u>PART NAME</u>	<u>QTY.</u>	<u>REMARKS</u>
1	01328800	INJECTOR ASSY.....	1	INCLUDES ITEMS W/\$
2\$	01582800	NOZZLE HOLDER ASSY	1	INCLUDES ITEMS W/#
3#\$		PIPE	1	NOT SOLD SEPARATELY
4#\$	05096101	SEALING CONE 4.9MM	AS REQUIRED ...	SEE TECHNICAL ADVICE 95125801
4	05070601	SEALING CONE 5.3MM	AS REQUIRED	
5#\$		NIPPLE BODY	1	NOT SOLD SEPARATELY
6#\$	05081500	SEALING CONE	1	
8\$	50436400	SHIM 1.00MM	1	
9\$	50436500	SHIM 1.04MM	1	
10\$	50436600	SHIM 1.10MM	1	
11\$	50436700	SHIM 1.14MM	1	
12\$	50436800	SHIM 1.20MM	1	
13\$	50436900	SHIM 1.24MM	1	
14\$	50437000	SHIM 1.30MM	1	
15\$	50437100	SHIM 1.34MM	1	
16\$	50437200	SHIM 1.40MM	1	
17\$	50437300	SHIM 1.44MM	1	
18\$	50437400	SHIM 1.50MM	1	
19\$	50437500	SHIM 1.54MM	1	
20\$	50437600	SHIM 1.60MM	1	
21\$	50437700	SHIM 1.64MM	1	
22\$	50437800	SHIM 1.70MM	1	
23\$	50437900	SHIM 1.74MM	1	
24\$	50438000	SHIM 1.80MM	1	
25\$	50438100	SHIM 1.84MM	1	
26\$	50438200	SHIM 1.90MM	1	
27\$	50438300	SHIM 1.94MM	1	
28+\$		SPRING	1	NOT SOLD SEPARATELY
29+\$		SPRING WASHER	1	NOT SOLD SEPARATELY
30+\$		PLATE	1	NOT SOLD SEPARATELY
31+\$	50442200	NOZZLE	1	IN EMERGENCY KIT
32+\$		BODY	1	NOT SOLD SEPARATELY
33	05070500	JOINT	1	IN HEAD GASKET SET

FUEL INJECTION ASSY.

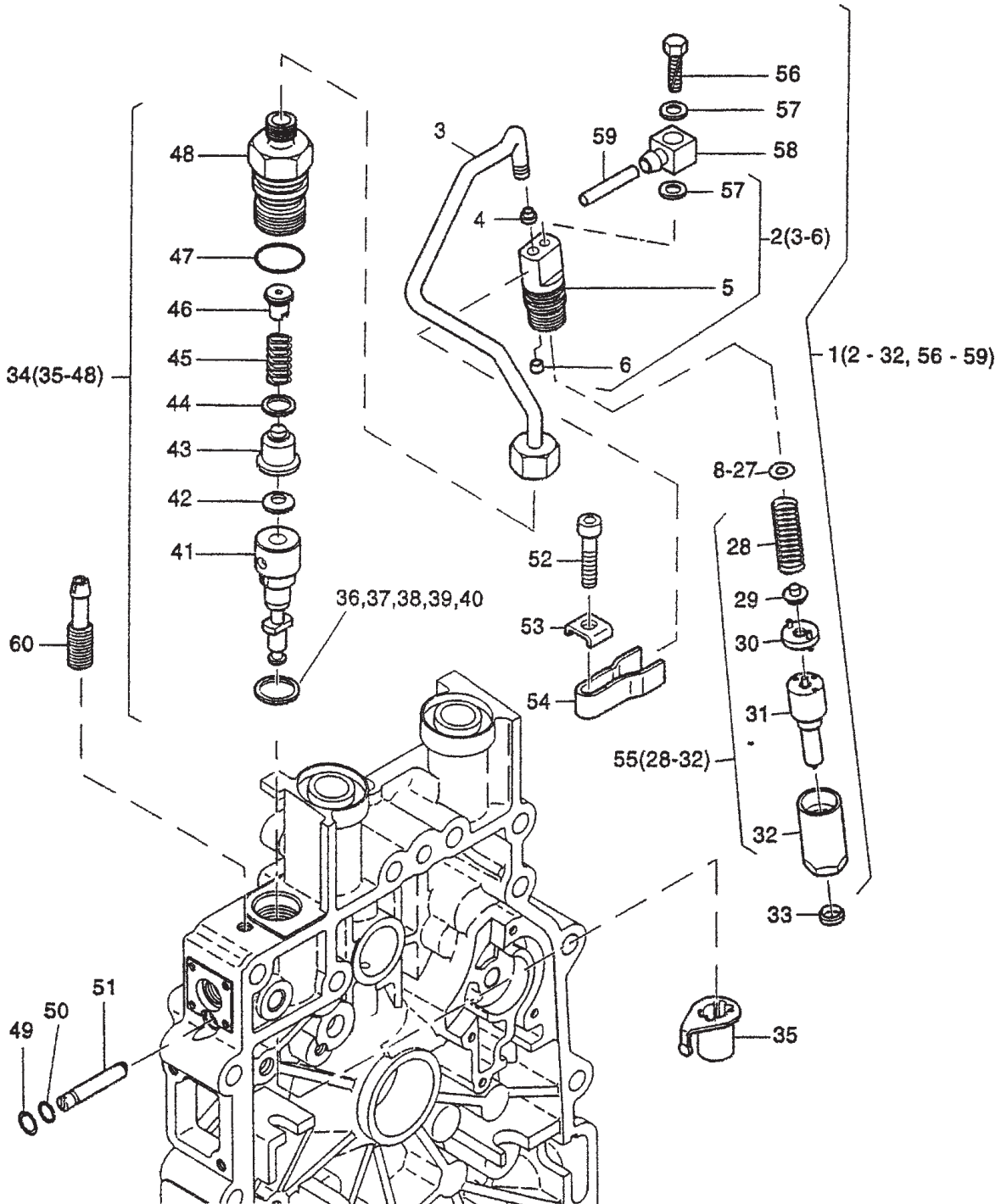

FUEL INJECTION ASSY.

FUEL INJECTION ASSY.

<u>NO.</u>	<u>PART NO.</u>	<u>PART NAME</u>	<u>QTY.</u>	<u>REMARKS</u>
34	01322200	INJECTION PUMP	1	INCLUDES ITEMS W/*
35*	01330800	CONTROL SLEEVE	1	
36*	04096300	SHIM 0.2MM	1	
37*	04096400	SHIM 0.3MM	1	
38*	04096500	SHIM 0.4MM	1	
39*	04096600	SHIM 0.5MM	1	
40*	04096700	SHIM 0.6MM	1	
41*		VALVE, FUEL INJECTOR PUMP	1	NOT SOLD SEPARATELY
42*	50471600	SPRING WASHER 8	1	
43*		BODY, FUEL INJECTOR PUMP	1	NOT SOLD SEPARATELY
44*	50476900	WASHER	1	
45*		SPRING, FUEL	1	NOT SOLD SEPARATELY
46*		BODY, FUEL	1	NOT SOLD SEPARATELY
47*	50476500	O- RING 17X2	1	
48*	50445900	VALVE HOLDER	1	
49	50476000	DISC 8	1	
50	50433900	O- RING 1.0X3.3	1	
51	04097700	PIN	1	
52	50323900	ALL. SCREW M6X30	1	
53	05089300	RETAINING YOKE	1	
54	05056700	FORK FOR INJECTOR	1	
60	05084201	CONNECTING NIPPLE	1	
55	01326100	PARTS SET NOZZLE ASSY.	1	INCLUDES ITEMS W/+
56\$	50464500	HEX SCREW M6X16	1	
57\$	50110800	JOINT A4X8	2	
58\$	05129000	CONNECTING NIPPLE	1	
59\$	05130300	HOSE 2.5X295	1	
60	05084201	CONNECTING NIPPLE	1	

RECOIL STARTER ASSY.

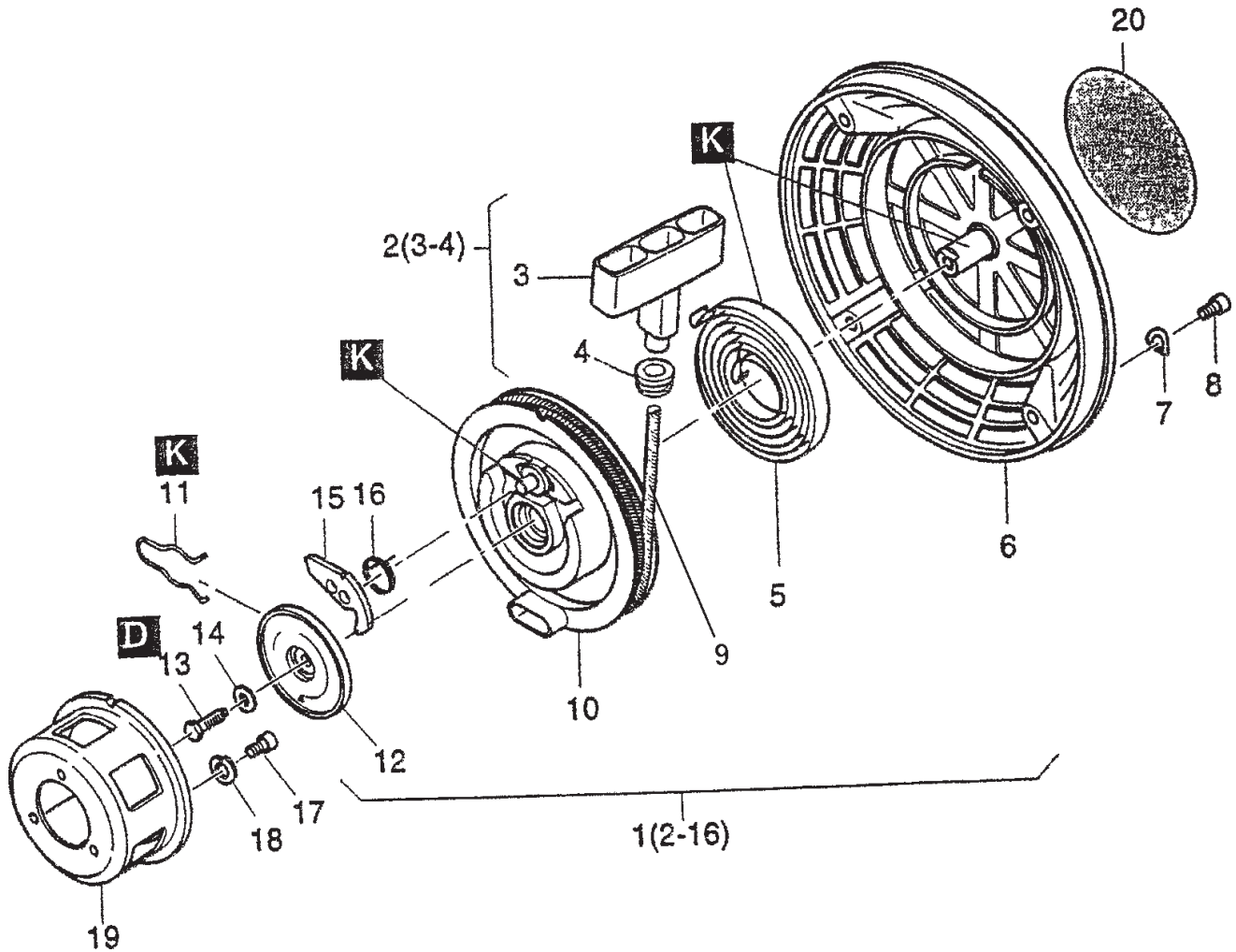

NOTE: Refer to Table 9 at the end of the manual for *letter* (A to L) call-outs.

RECOIL STARTER ASSY.

RECOIL STARTER ASSY.

<u>NO.</u>	<u>PART NO.</u>	<u>PART NAME</u>	<u>QTY.</u>	<u>REMARKS</u>
1	01515002	RECOIL STARTER ASSY.	1	INCLUDES ITEMS W/*
2*	01497800	HANDLE ASSY.	1	INCLUDES ITEMS W/#
4*#		HANDLE	1	NOT SOLD SEPARATELY
4*#	03665200	RUBBER SLEEVE	1	
5*	05045201	RETURN SPRING	1	
6*	01569300	HOUSING RECOIL STARTER	1	
7*	50081200	SPRING WASHER A6	4	
8*	50062700	ALLEN SCREW M6X10	4	
9*	05088901	ROPE RECOIL STARTER	1	
10*	01548800	ROPE PULLEY	1	
11*	05044901	BRAKE SPRING	1	
12*	05045001	BRAKE DISK	1	
13*	50146300	HEX SCREW M6X18	1	
14*	50165600	SPRING WASHER	1	
15*	05044800	RATCHET	1	
16*	05061300	RETURN SPRING	1	
17	50062700	ALLEN SCREW M6X10	3	
18	50170900	SPRING WASHER 6	3	
19	50445800	DRIVING SLEEVE	1	
20	05109100	STICKER LABEL	1	

AIR DUCT ASSY.

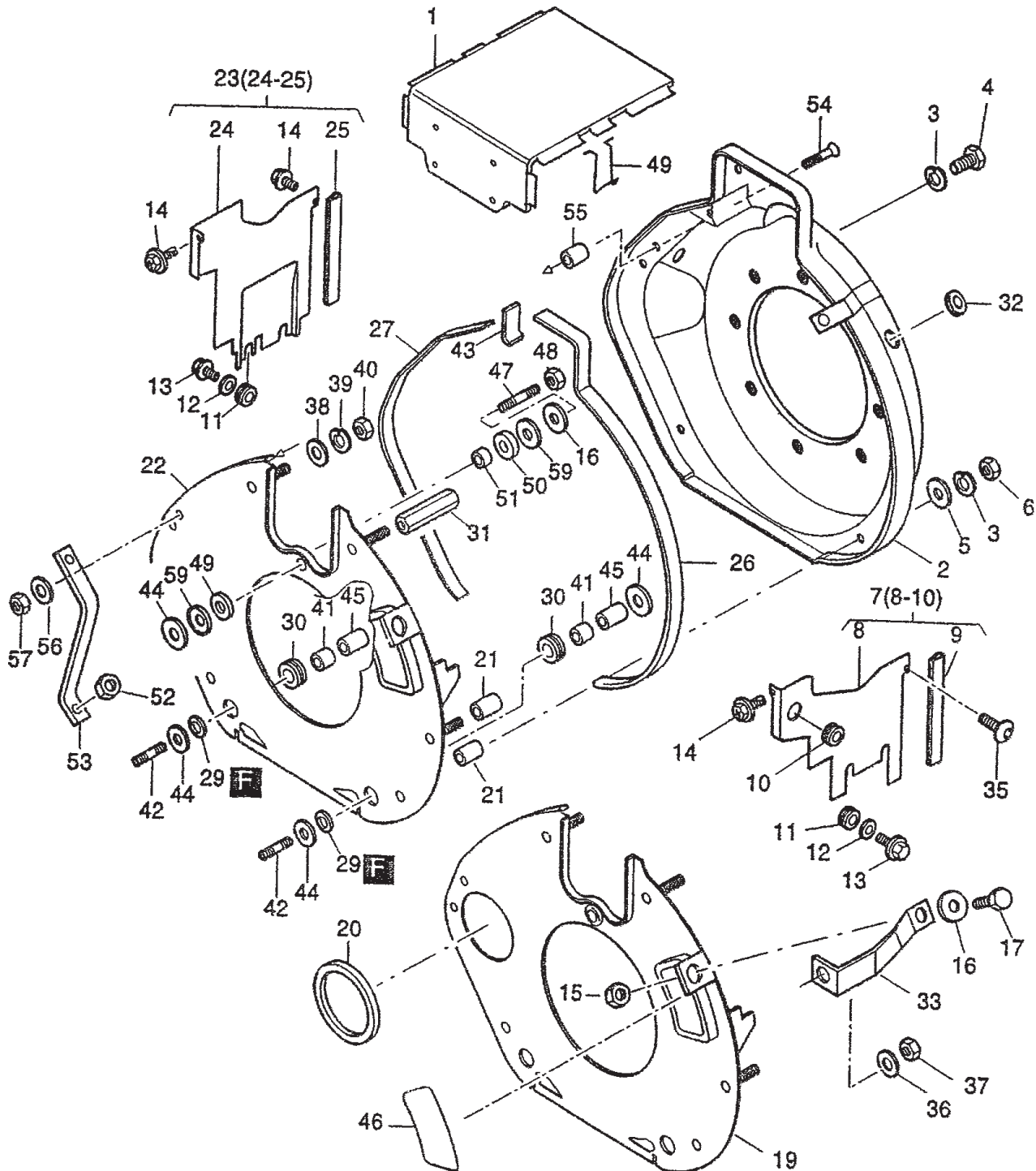

NOTE: Refer to Table 9 at the end of the manual for *letter* (A to L) call-outs.

AIR DUCT ASSY.

AIR DUCT ASSY.

<u>NO.</u>	<u>PART NO.</u>	<u>PART NAME</u>	<u>QTY.</u>	<u>REMARKS</u>
1	01551401	HOOD	1	
2	01551301	BLOWER DUCTING	1	
3	50170900	SPRING WASHER 6	7	
4	50146300	HEX SCREW M6X18	1	
5	50120000	DISC A6,4	2	
6	50144400	HEX NUT M6	6	
7	01326300	COOLING AIR DUCTING	1	INCLUDES ITEMS W/*
8*		AIR DUCT -----	1	NOT SOLD SEPARATELY
9*	05128900	SEALING STRIP 80MM	1	
10*	50334800	RUBBER SLEEVE	1	
11	50163801	RUBBER SLEEVE	3	
12	50441600	WASHER 4,3	3	
13	50445400	HEX. SCREW M4X10	3	
14	50335600	COMBI SCREW M6X16	3	
15	50144400	HEX. NUT M6	1	
16	50114300	DISK 6,4	2	
17	50177100	HEX. SCREW M6X16	1	
19	01326800	PARTING SHEET	1	ELECTRIC START ONLY
20	04099500	SEALING RING	1	
21	04098400	SPACER TUBE 7X12X16.3	5	
22	01326700	PARTING SHEET	1	
23	01326200	COOLING AIR DUCT	1	INCLUDES ITEMS W/#
24#		AIR DUCT	1	NOT SOLD SEPARATELY
25#	04111500	SEALING STRIP 119MM	1	
26	05108100	SEALING STRIP 495MM	1	
27	04124600	SEALING STRIP 388MM	1	
29	03575500	SEALING RING	2	
30	00921400	SPACER BUSHING	2	
31	05081700	SPACER	1	
32	50453300	RUBBER SLEEVE	1	
33	01599600	SUPPORT	1	
35	50328000	CTR. SUNK SCREW AM6X16	1	
36	50095100	SPRING WASHER A8	1	
37	50344700	HEX. NUT M8	1	
38	50144500	FLAT WASHER 6,4	1	
39	50170900	SPRING WASHER 6	1	

AIR DUCT ASSY.

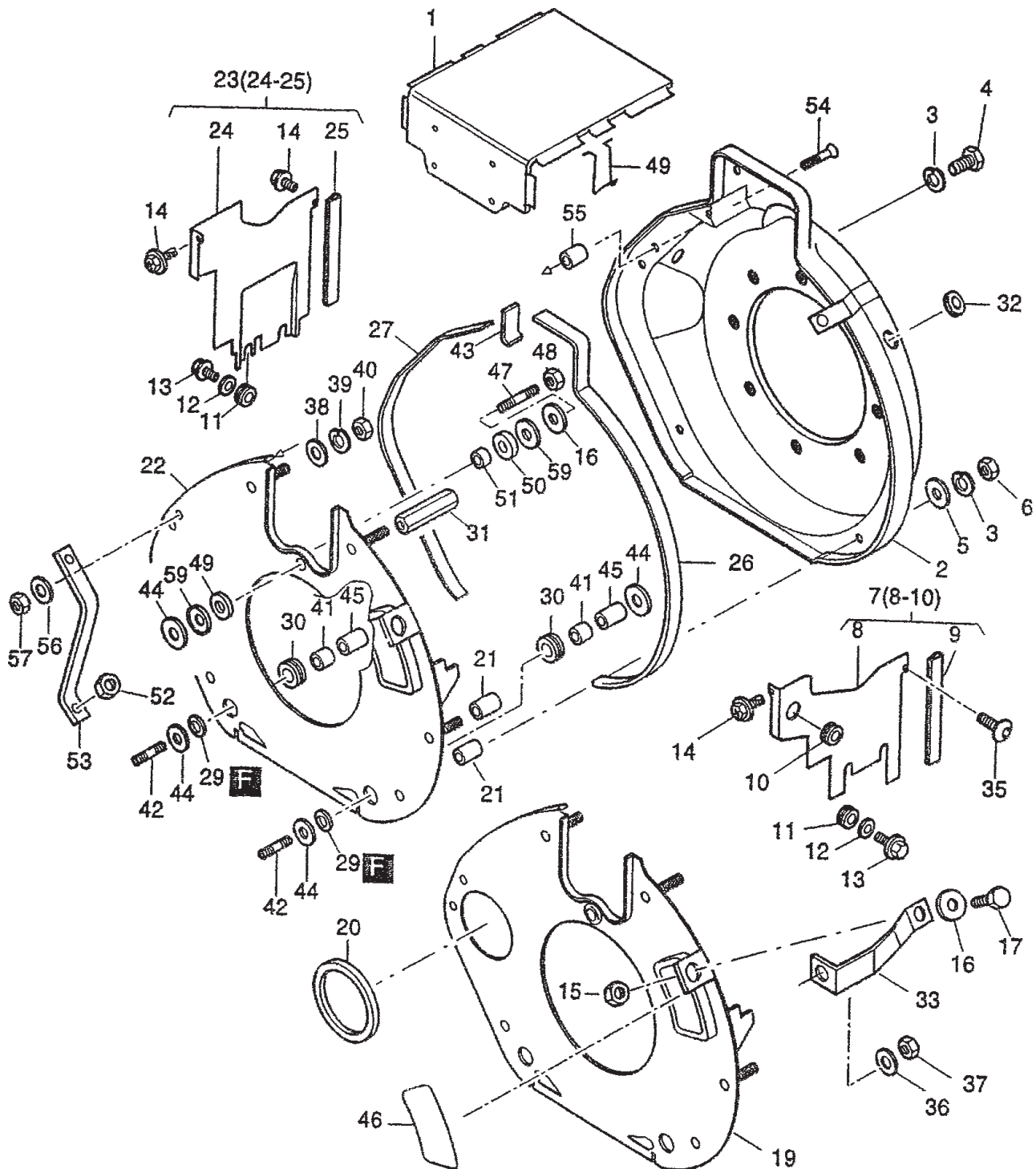

NOTE: Refer to Table 9 at the end of the manual for *letter* (A to L) call-outs.

AIR DUCT ASSY.

AIR DUCT ASSY. (cont.)

<u>NO.</u>	<u>PART NO.</u>	<u>PART NAME</u>	<u>QTY.</u>	<u>REMARKS</u>
40	50144400	HEX. NUT M6	1	
41	04119100	TUBE 6X8X14	2	
42	50458100	STUD M6X45	2	
43	05007300	SEALING STRIP 48MM	1	
44	04042000	WASHER 6.5X22.5X1	5	
45	05132900	BUSH 6.5X13X14	2	
46	04116700	COVER	1	
47	50464401	STUD M6X35	1	
48	40028300	HEX. NUT M6	1	
49	05133800	RUBBER RING 17X28X5	1	
50	05133900	RUBBER RING 17X28X9	1	
50	05133900	RUBBER RING 17X28X9	1	
51	05132700	BUSH 6.5X17Z11.5	1	
52	50148000	HEX. NUT M8	1	
53	05133000	SUPPORT FUEL TANK	1	
54	50445000	CTR. SUNK SCREW M6X35	1	
55	05132800	SPACER TUBE 7X12X16.3	1	
56	50170900	SPRING WASHER 6	1	
57	50144400	HEX NUT M 6	1	
58	05145800	SPRING CLIP	1	
59	05097600	WASHER	2	

CRANKCASE BREATHER ASSY.

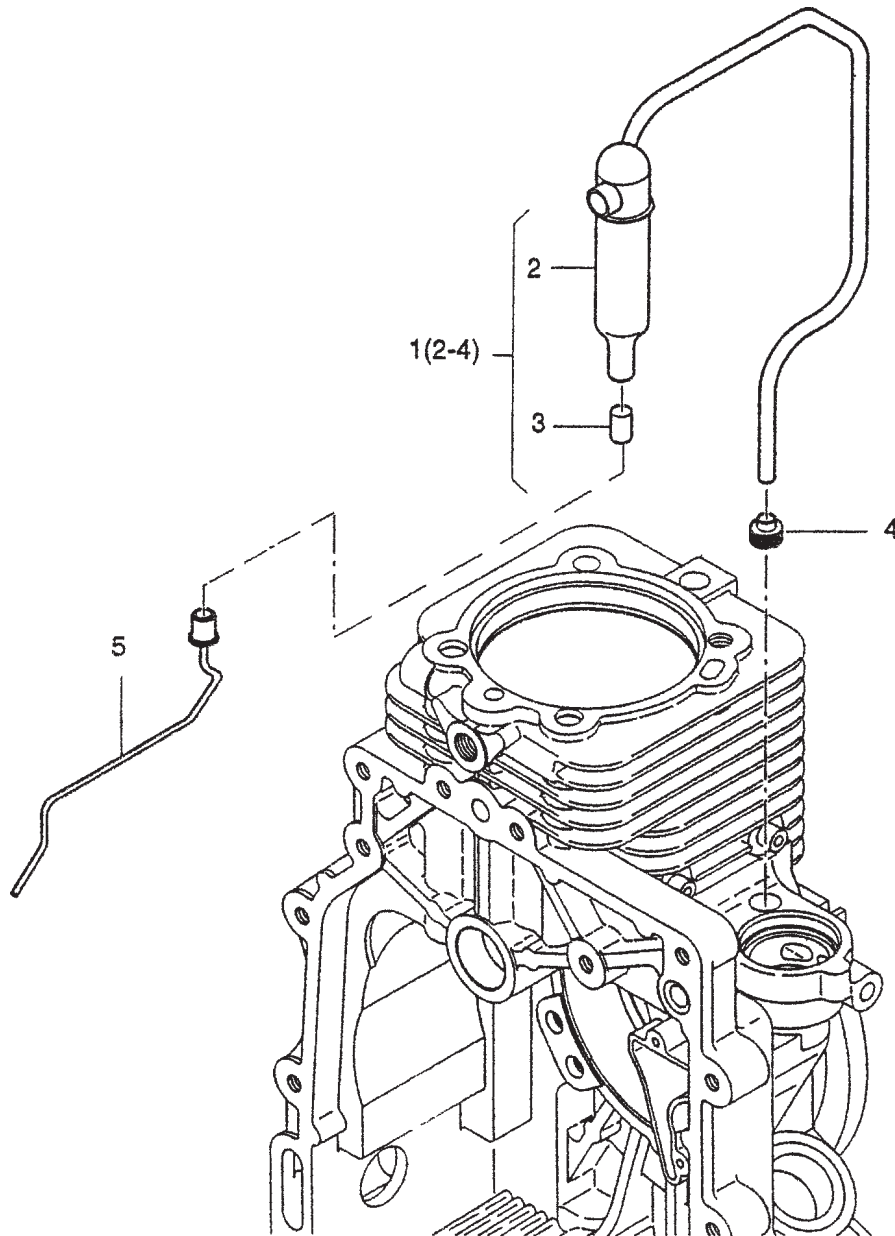

CRANKCASE BREATHER ASSY.

CRANKCASE BREATHER ASSY.

<u>NO.</u>	<u>PART NO.</u>	<u>PART NAME</u>	<u>QTY.</u>	<u>REMARKS</u>
1	01599200	OIL SEPARATOR ASSY.	1	INCLUDES ITEMS W/*
2*		OIL SEPARATOR	1	NOT SOLD SEPARATELY
3*	05102900	FILTER BREATHER SYSTEM	1	
4*	01617900	BREATHER TUBE	1	IN CRANKCASE GASKET SET
5	01551600	SUCTION PIPE	1	

FUEL TANK ASSY. (OLD STYLE)

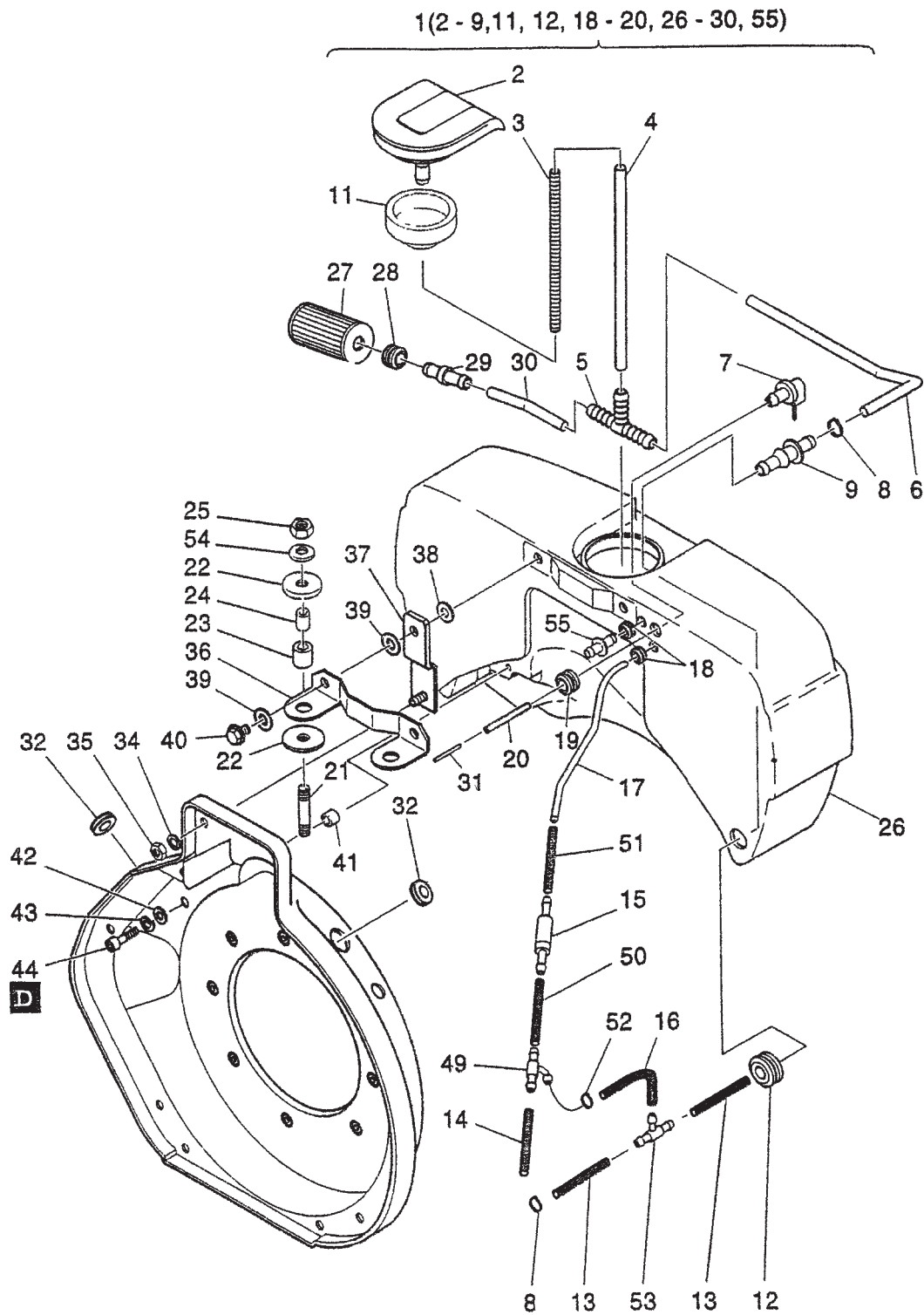

NOTE: Refer to Table 9 at the end of the manual for *letter* (A to L) call-outs.

FUEL TANK ASSY. (OLD STYLE)

FUEL TANK ASSY. (OLD STYLE)

<u>NO.</u>	<u>PART NO.</u>	<u>PART NAME</u>	<u>QTY.</u>	<u>REMARKS</u>
1	01588610	FUEL TANK ASSY 5 LITER	1	INCLUDES ITEMS W/*
2*	01535302	CAP FOR FUEL TANK	1	
3*		FUEL HOSE WRAP	1	NOT SOLD SEPARATELY
4*	05085100	FUEL HOSE 7X165	1	
5*	50440600	NIPPLE FOR FUEL TANK	1	
6*	05137000	FUEL PIPE 7X220	1	
7*	01534900	FUEL VENT VALVE	1	
8*	50441100	HOSE CLIP	2	IN EMERGENCY KIT
9*	05084000	CONNECTING NIPPLE	1	
11	05086401	GASKET FOR FUEL CAP	1	
12*	50440800	RUBBER SLEEVE	1	
13	05123100	FUEL HOSE 7/70	2	
14	05085300	FUEL HOSE 3.5X45	1	
15	01534600	FUEL VENT VALVE	1	
16	03673300	FUEL HOSE 4.5/170	1	
17	05122200	FUEL PIPE	1	
18*	05130400	RUBBER SLEEVE	2	
19*	50440900	RUBBER SLEEVE	1	
20*	05085600	BREATHER HOSE	1	
21	50231900	STUD M8X25	2	
22	05109810	DISK 8.2X22X2	4	
23	05086810	RUBBER SHELL	2	
24	05122800	INSULATING SLEEVE	2	
25	40028400	HEX. NUT M8	2	
26*		FUEL TANK	1	NOT SOLD SEPARATELY
27*	01635200	FUEL FILTER	1	IN MAINTENANCE KIT
			INCLUDES ITEMS W/#
28*#	50440900	RUBBER SLEEVE	1	
29*	05084400	CONNECTING NIPPLE	1	
30*	05136900	FUEL PIPE 7X80	1	
31	05085500	TUBE 1.4X2X16	1	
34	50170900	SPRING WASHER 6	2	
35	50144400	HEX. NUT M6	2	
36	05122300	SUPPORT	1	
37	01331300	SUPPORT	2	
38	50120000	DISK A6,4	2	
39	05110010	DISK 7.1X17.9X2	4	
40	01588900	HEX. SCREW M6X16	2	
41	04118800	DISK 6.5X13X4.8	4	
42	50144500	FLAT WASHER 6,4	4	
43	50170900	SPRING WASHER 6	4	
44	50170700	ALL. SCREW M6X16	4	
49	05122700	HOSE NIPPLET	1	
50	05123200	FUEL HOSE 3.5X38	1	
51	04060400	FUEL HOSE 4.5X100	1	
52	50399801	CLAMP 11,3	1	
53	50459600	HOSE NIPPLE T	1	
54	50148100	FLAT WASHER 8,4	2	
55*	05129610	CONNECTING NIPPLE	1	

FUEL TANK ASSY. (NEW STYLE)

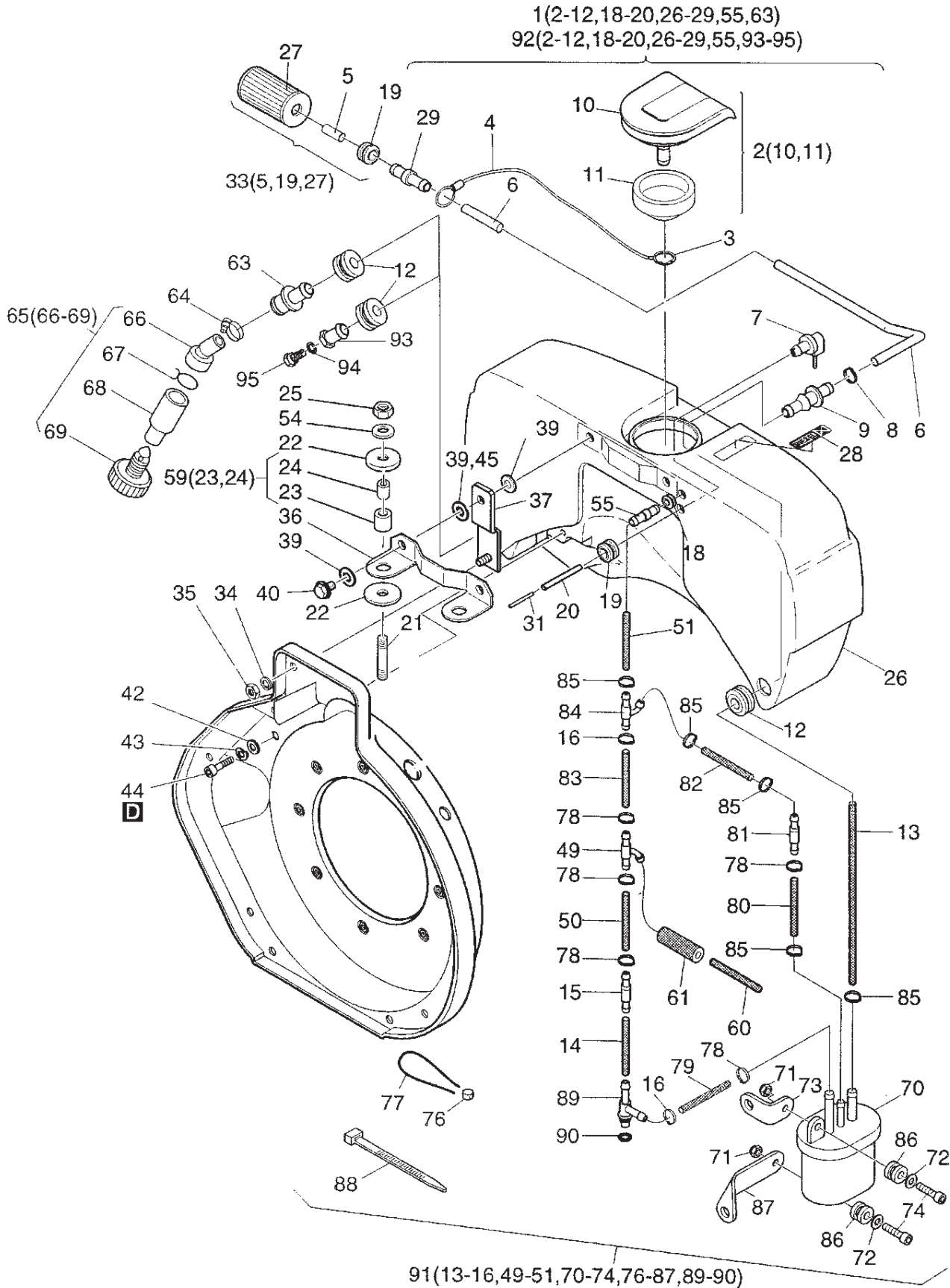

FUEL TANK ASSY. (NEW STYLE)

FUEL TANK ASSY. (NEW STYLE)

<u>NO.</u>	<u>PART NO.</u>	<u>PART NAME</u>	<u>QTY.</u>	<u>REMARKS</u>
1	01666710	FUEL TANK ASSY 5 LITER	1	INCLUDES ITEMS W/ *
2#*	01535302	CAP FOR FUEL TANK	1	INCLUDES ITEMS W/ &
3#*	50500800	CIRCLIP 8	1	
4#*	01628900	ROPE	1	
5\$#*		SPACER	1	NOT SOLD SEPARATELY
6#*	05189900	FUEL HOSE 3.5 X 300	1	
7#*	01534900	FUEL VENT VALVE	1	
8#*	50399801	CLAMP	1	
9#*	05084000	CONNECTING NIPPLE	1	
10&		FUEL CAP	1	NOT SOLD SEPARATELY
11& #*	05086401	GASKET FOR FUEL CAP	1	
12#*	50440800	RUBBER SLEEVE	2	
13+	05347600	FUEL HOSE 3.5X215	1	
	05284000	FUEL PIPE 3.5 X 190	1	
14+	05123200	FUEL HOSE 3.5X40	1	
15+	01534600	FUEL VENT VALVE	1	
	00805502	VENT VALVE	1	
16+	50590000	CLAMP 12.0	2	
18#*	05130400	RUBBER SLEEVE	1	
19\$#*	50440901	RUBBER SLEEVE	2	
20#*	05085601	BREATHER HOSE 1X3X100	1	
	05085600	BREATHER HOSE 1X3X85	1	
21	50231900	STUD M8X25	2	
22	05109810	DISK 8.2X22X2	4	
23@		RUBBER SHELL	2	NOT SOLD SEPARATELY
24@	05122800	INSULATING SLEEVE	2	
25	40028400	HEX. NUT M8	2	
26#*		FUEL TANK	1	NOT SOLD SEPARATELY
27\$#*		FUEL FILTER	1	NOT SOLD SEPARATELY
28#*	05235602	DECAL, "DIESEL"	1	
29#*	05189001	CONNECTING NIPPLE	1	
31	05085500	TUBE 2X0.3X16	1	
33	01635210	FUEL FILTER	1	INCLUDES ITEMS W/ \$
34	50170900	SPRING WASHER 6	2	
35	50144400	HEX. NUT M6	2	
36	05122300	SUPPORT	1	
37	01331300	SUPPORT	2	
39	05110010	DISK 7.1X17.9X2	4	
40	01677100	HEX. SCREW M6X20	2	
42	50144500	FLAT WASHER 6,4	4	
43	50170900	SPRING WASHER 6	4	
44	50170700	ALL. SCREW M6X16	4	
45	50114300	DISK 6,4	2	
49+	05175601	HOSE NIPPLET	1	
50+	03807100	FUEL HOSE 5.0X150	1	

FUEL TANK ASSY. (NEW STYLE)

FUEL TANK ASSY. (NEW STYLE - cont.)

<u>NO.</u>	<u>PART NO.</u>	<u>PART NAME</u>	<u>QTY.</u>	<u>REMARKS</u>
51+	03663800	FUEL HOSE 5.0X40	1	
52	50399801	CLAMP 11,3	1	
53	50459600	HOSE NIPPLE T	1	
54	50148100	FLAT WASHER 8,4	2	
55#*	05184400	CONNECTING NIPPLE	1	
59	01655800	INSULATING TUBE	2	INCLUDES ITEMS W/ @
60	05215000	HOSE 2.5 X195	1	
61	05213000	INSUL. HOSE 7 X25	1	
63*	05172300	CONNECTING NIPPLE	1	
64	50448000	CLAMP	1	
65	01519402	WATER SEPARATOR	1	INCLUDES ITEMS W/ %
66%	05044001	HOSE 20/12 MM	1	
67%	05036900	HOUSE CLIP	1	
68%	05043901	WATER SEPARATOR	1	
69%	50414800	CLOS. SCREW M10	1	
70+	50539200	FUEL FILTER EXTERNAL MOUNT	1	
71+	50501600	HEX NUT M4	2	
72+	50441600	WASHER 4.3	2	
73+	05279500	SUPPORT	1	
74+	50546900	PRESSURE SPRING	1	
75	05259301	DECAL	1	
76+	40021400	LEAD SEAL 8MM	1	
77+	40021500	SEAL WIRE	1	
78+	50399801	CLAMP11,3	9	
79+	05283900	FUEL PIPE 5.0 X 285	1	
80+	05283900	FUEL PIPE 5.0 X 285	1	
81+	01534601	FUEL VENT G VALVE	1	
82+	03663700	FUEL HOSE 5.0 X 50	1	
83+	03663800	FUEL HOSE 5.0 X 40	1	
84+	05122701	HOSE NIPPLE T	1	
85+	50441100	HOSE CLIP	2	
86+	50556600	RUBBER SLEEVE	2	
87+	05279400	SUPPORT	1	
88	50358400	STRAP	2	
89+	01756800	NIPPLE	1	
90+	50154300	O-RING 7.5 X 10.5 X 1.5	1	
91	01778430	FUEL PIPE	1	INCLUDES ITEMS W/ +
92	01588620	FUEL TANK 5L	1	INCLUDES ITEMS W/ #
93#	05188200	CONNECTING NIPPLE	1	
94#	50313100	JOINT A 6 X 10	1	
95#	03613600	VENT SCREW M6	1	

AIR FILTER ASSY.

AIR FILTER ASSY.

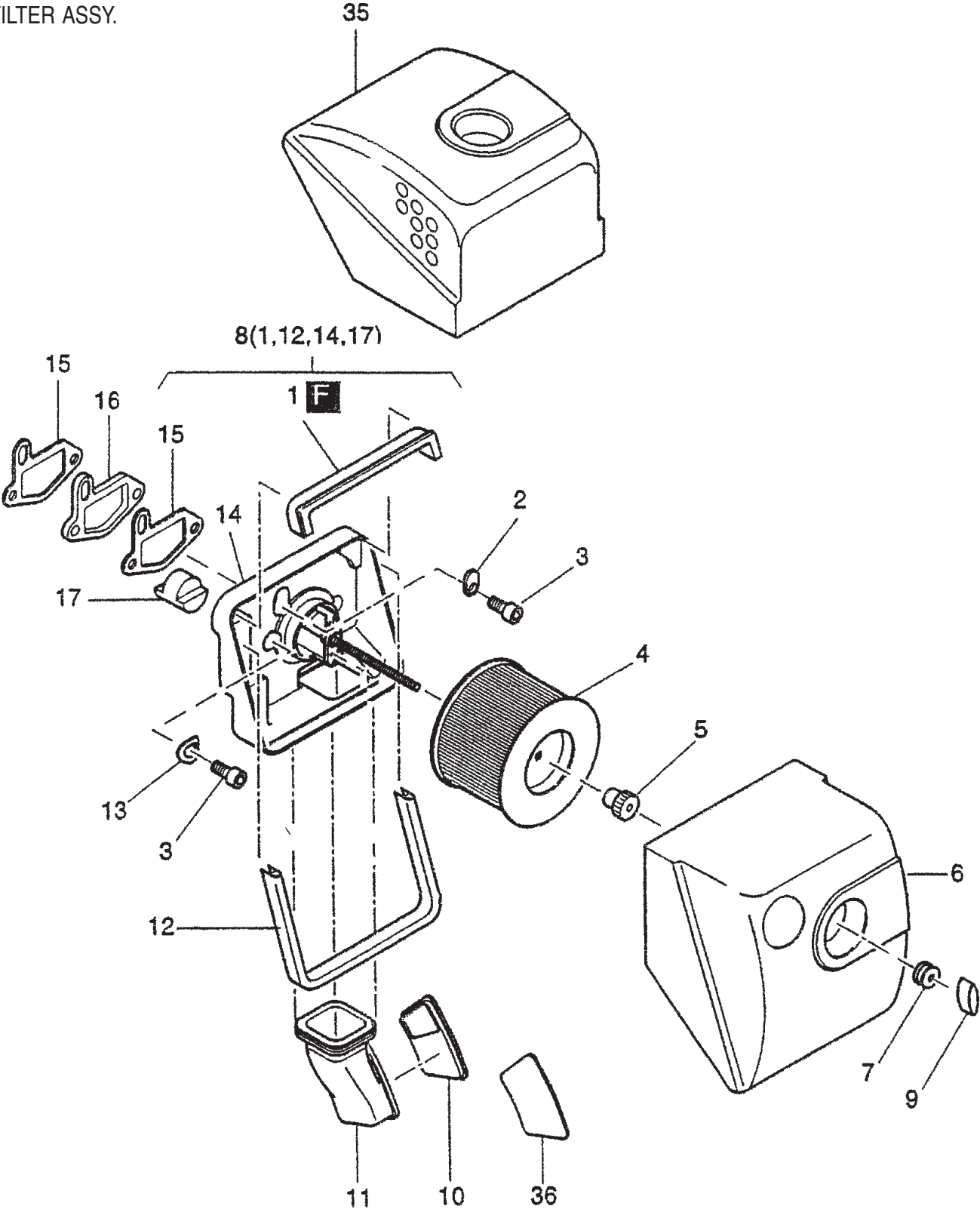

NOTE: Refer to Table 9 at the end of the manual for *letter* (A to L) call-outs.

AIR FILTER ASSY.

AIR FILTER ASSY.

<u>NO.</u>	<u>PART NO.</u>	<u>PART NAME</u>	<u>QTY.</u>	<u>REMARKS</u>
1*	05107600	SEALING STRIP	1	
2	05056400	WASHER	1	
3	50171500	ALL. SCREW M8X25	3	
4	50426000	AIR FILTER ELEMENT	1 IN MAINTENANCE KIT
5	50454300	NUT M6	1	
6	05107500	COVER AIR FILTER	1	
7	50435800	RUBBER SLEEVE	1	
8	01607900	AIR FILTER HOUSING ASSY	1 INCLUDES ITEMS W/*
9	50452200	WING NUT M6	1	
10	04116600	COVER, RUBBER INSERT	1	
11	04116501	RUBBER INSERT	1	
12*	05056100	SEALING STRIP 365MM	1	
13	50095100	SPRING WASHER A8	2	
14		AIR FILTER ASSY	1 NOT SOLD SEPARATELY
15	05056300	GASKET AIR FILTER.....	2 IN HEAD GASKET SET
16	05088300	INSULATING FLANGE	1	
17*	05098100	PLUG	1	
35	05132000	COVER AIR FILTER	1	
36	04116700	COVER	1	

MUFFLER ASSY.

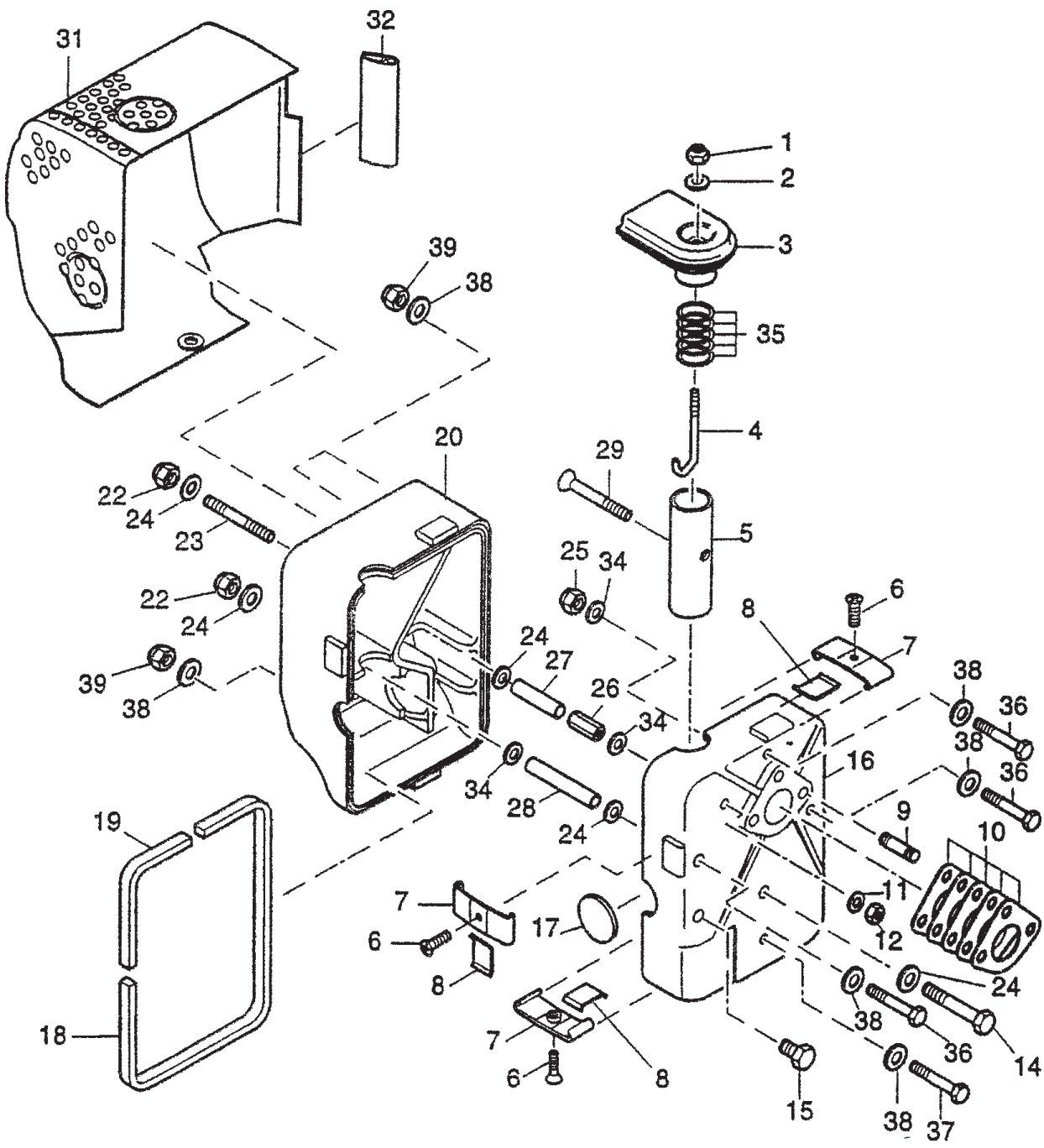

MUFFLER ASSY.

MUFFLER ASSY.

<u>NO.</u>	<u>PART NO.</u>	<u>PART NAME</u>	<u>QTY.</u>	<u>REMARKS</u>
1	40028300	HEX. NUT M6	1	
2	50144500	FLAT WASHER 6,4	1	
3	01531311	EXHAUST END PIPE	1	
4	05081101	THREADED BOLT M6	1	
5	05081410	EXHAUST TUBE	1	
6	50422500	CTR. SUNK SCREW M6X12	3	
7	01531201	CLAMP	3	
8	05081611	SUPPORTING PLATE	3	
9	50128100	STUD	3	
10	05103600	MUFFLER GASKET 1B30	5 IN HEAD GASKET SET
11	50144500	FLAT WASHER 6,4	1	
12	40028300	HEX NUT M6	1	
14	50028900	HEX. SCREW M8X100	1	
15	50450500	HEX. SCREW M8X10	1	
16	05103401	MUFFLER, INNER PART	1	
17	05081002	COVER	1	
18	05104100	SEALING STRIP	1	
19	05104000	SEALING STRIP	1	
20	05103500	MUFFLER, OUTER PART	1	
22	40028400	HEX. NUT M8	3	
23	50445201	STUD M8X70	1	
24	50148100	FLAT WASHER 8,4	6	
25	40028400	HEX. NUT M8	1	
26	05083900	SPACER NUT M8	1	
27	05103901	SPACER TUBE 51.6MM	1	
28	05103801	SPACER TUBE 65MM	1	
29	50445000	CTR. SUNK. SCREW M6X35	1	
31	01560200	MUFFLER GUARD	1	
32	05100300	SEALING STRIP 65MM	1	
34	04054300	WASHER 8.4X23.5	3	
35	05127000	WASHER 28.1X34X0.5	5	
36	50460700	HEX. SCREW M6X100	3	
37	50460800	HEX. SCREW M6X55	1	
38	50144500	FLAT WASHER 6,4	8	
39	40028300	HEX. NUT M6	4	

SEALING AND BONDING ADHESIVES

TABLE 9. SEALING AND BONDING ADHESIVES

Item	Part Number	Description	Amount
A	50223001	Loctite Activator	500 ml
B	50223100	Loctite 573	50 ml
C	50223200	Loctite 601	50 ml
D	50223300	Loctite 221	50 ml
E	50223400	Loctite 648	10 ml
F	50223800 + 50223900	Technicoll 8058 Technicoll 8367	0.75 kg 0.75 kg
G	50256501	Loctite IS 407	10 g
H	50282501	Silicon	30 ml
J	50283003	High Temp Paste	100 ml
K	50342600	High Temp Grease	100 g
L	50256600	Silicon Sealer	100 g

TERMS AND CONDITIONS OF SALE — PARTS

PAYMENT TERMS

Terms of payment for parts are net 30 days.

FREIGHT POLICY

All parts orders will be shipped collect or prepaid with the charges added to the invoice. All shipments are F.O.B. point of origin. Multiquip's responsibility ceases when a signed manifest has been obtained from the carrier, and any claim for shortage or damage must be settled between the consignee and the carrier.

MINIMUM ORDER

The minimum charge for orders from Multiquip is \$15.00 net. Customers will be asked for instructions regarding handling of orders not meeting this requirement.

RETURNED GOODS POLICY

Return shipments will be accepted and credit will be allowed, subject to the following provisions:

1. A Returned Material Authorization must be approved by Multiquip prior to shipment.
2. To obtain a Return Material Authorization, a list must be provided to Multiquip Parts Sales that defines item numbers, quantities, and descriptions of the items to be returned.
 - a. The parts numbers and descriptions must match the current parts price list.
 - b. The list must be typed or computer generated.
 - c. The list must state the reason(s) for the return.
 - d. The list must reference the sales order(s) or invoice(s) under which the items were originally purchased.
 - e. The list must include the name and phone number of the person requesting the RMA.
3. A copy of the Return Material Authorization must accompany the return shipment.
4. Freight is at the sender's expense. All parts must be returned freight prepaid to Multiquip's designated receiving point.

5. Parts must be in new and resalable condition, in the original Multiquip package (if any), and with Multiquip part numbers clearly marked.
6. The following items are not returnable:
 - a. Obsolete parts. (If an item is in the price book and shows as being replaced by another item, it is obsolete.)
 - b. Any parts with a limited shelf life (such as gaskets, seals, "O" rings, and other rubber parts) that were purchased more than six months prior to the return date.
 - c. Any line item with an extended dealer net price of less than \$5.00.
 - d. Special order items.
 - e. Electrical components.
 - f. Paint, chemicals, and lubricants.
 - g. Decals and paper products.
 - h. Items purchased in kits.
7. The sender will be notified of any material received that is not acceptable.
8. Such material will be held for five working days from notification, pending instructions. If a reply is not received within five days, the material will be returned to the sender at his expense.
9. Credit on returned parts will be issued at dealer net price at time of the original purchase, less a 15% restocking charge.
10. In cases where an item is accepted, for which the original purchase document can not be determined, the price will be based on the list price that was effective twelve months prior to the RMA date.
11. Credit issued will be applied to future purchases only.

PRICING AND REBATES

Prices are subject to change without prior notice. Price changes are effective on a specific date and all orders received on or after that date will be billed at the revised price. Rebates for price declines and added charges for price increases will not be made for stock on hand at the time of any price change.

Multiquip reserves the right to quote and sell direct to Government agencies, and to Original Equipment Manufacturer accounts who use our products as integral parts of their own products.

SPECIAL EXPEDITING SERVICE

A \$35.00 surcharge will be added to the invoice for special handling including bus shipments, insured parcel post or in cases where Multiquip must personally deliver the parts to the carrier.

LIMITATIONS OF SELLER'S LIABILITY

Multiquip shall not be liable hereunder for damages in excess of the purchase price of the item with respect to which damages are claimed, and in no event shall Multiquip be liable for loss of profit or good will or for any other special, consequential or incidental damages.

LIMITATION OF WARRANTIES

No warranties, express or implied, are made in connection with the sale of parts or trade accessories nor as to any engine not manufactured by Multiquip. Such warranties made in connection with the sale of new, complete units are made exclusively by a statement of warranty packaged with such units, and Multiquip neither assumes nor authorizes any person to assume for it any other obligation or liability whatever in connection with the sale of its products. Apart from such written statement of warranty, there are no warranties, express, implied or statutory, which extend beyond the description of the products on the face hereof.

Effective: February 22, 2006

OPERATION AND PARTS MANUAL

HERE'S HOW TO GET HELP

PLEASE HAVE THE MODEL AND SERIAL
NUMBER ON-HAND WHEN CALLING

UNITED STATES

Multiquip Corporate Office

18910 Wilmington Ave.
Carson, CA 90746
Contact: mq@multiquip.com

Tel. (800) 421-1244
Fax (800) 537-3927

MQ Parts Department

800-427-1244 Fax: 800-672-7877
310-537-3700 Fax: 310-637-3284

Mayco Parts

800-306-2926
310-537-3700

Fax: 800-672-7877
Fax: 310-637-3284

Warranty Department

800-421-1244, Ext. 279 Fax: 310-537-1173
310-537-3700, Ext. 279

Service Department

800-421-1244
310-537-3700

Fax: 310-537-4259

Technical Assistance

800-478-1244 Fax: 310-631-5032

MEXICO

MQ Cipsa

Carr. Fed. Mexico-Puebla KM 126.5
Momoxpan, Cholula, Puebla 72760 Mexico
Contact: pmastretta@cipsa.com.mx

Tel: (52) 222-225-9900
Fax: (52) 222-285-0420

UNITED KINGDOM

Multiquip (UK) Limited Head Office

Unit 2, Northpoint Industrial Estate,
Global Lane,
Dukinfield, Cheshire SK16 4UJ
Contact: sales@multiquip.co.uk

Tel: 0161 339 2223
Fax: 0161 339 3226

CANADA

Multiquip

4110 Industriel Boul.
Laval, Quebec, Canada H7L 6V3
Contact: jmartin@multiquip.com

Tel: (450) 625-2244
Tel: (877) 963-4411
Fax: (450) 625-8664

© COPYRIGHT 2010, MULTIQUIP INC.

Multiquip Inc and the MQ logo are registered trademarks of Multiquip Inc. and may not be used, reproduced, or altered without written permission. All other trademarks are the property of their respective owners and used with permission.

This manual MUST accompany the equipment at all times. This manual is considered a permanent part of the equipment and should remain with the unit if resold.

The information and specifications included in this publication were in effect at the time of approval for printing. Illustrations, descriptions, references and technical data contained in this manual are for guidance only and may not be considered as binding. Multiquip Inc. reserves the right to discontinue or change specifications, design or the information published in this publication at any time without notice and without incurring any obligations.

Your Local Dealer is:



Free Manuals Download Website

<http://myh66.com>

<http://usermanuals.us>

<http://www.somanuals.com>

<http://www.4manuals.cc>

<http://www.manual-lib.com>

<http://www.404manual.com>

<http://www.luxmanual.com>

<http://aubethermostatmanual.com>

Golf course search by state

<http://golfingnear.com>

Email search by domain

<http://emailbydomain.com>

Auto manuals search

<http://auto.somanuals.com>

TV manuals search

<http://tv.somanuals.com>