

# OPERATION AND PARTS MANUAL



**MULTIQUIP**

*Diamond Back*

**SP2 "STREET-PRO"**

**SLAB SAW**

**13HP & 20HP**

**HONDA GASOLINE ENGINES**

**SP213H20, SP2S13H20, SP2S20H20**

MODEL # \_\_\_\_\_

SERIAL # \_\_\_\_\_

Revision #7 (09/08/06)



**MULTIQUIP INC.**

18910 WILMINGTON AVE.  
CARSON, CALIFORNIA 90746  
310-537-3700  
800-421-1244  
FAX: 310-537-3927

**E-mail: [mq@multiquip.com](mailto:mq@multiquip.com) • [www.multiquip.com](http://www.multiquip.com)**

Atlanta • Boise • Dallas • Houston • Newark  
Montreal, Canada • Manchester, UK  
Rio De Janeiro, Brazil • Guadalajara, Mexico

**PARTS DEPARTMENT:**

800-427-1244  
FAX: 800-672-7877

**SERVICE DEPARTMENT/TECHNICAL ASSISTANCE:**

800-478-1244  
FAX: 310-631-5032

© COPYRIGHT 2003, MULTIQUIP INC.

**P/N 35101**



# WARNING



## **CALIFORNIA — Proposition 65 Warning**

Engine exhaust and some of its constituents, and some dust created by power sanding, sawing, grinding, drilling and other construction activities contains chemicals known to the State of California to cause cancer, birth defects and other reproductive harm. Some examples of these chemicals are:

- Lead from lead-based paints.
- Crystalline silica from bricks.
- Cement and other masonry products.
- Arsenic and chromium from chemically treated lumber.

Your risk from these exposures varies, depending on how often you do this type of work. To reduce your exposure to these chemicals: **ALWAYS** work in a well ventilated area, and work with approved safety equipment, such as dust masks that are specially designed to filter out microscopic particles.

## **HERE'S HOW TO GET HELP**

*PLEASE HAVE THE MODEL AND SERIAL  
NUMBER ON-HAND WHEN CALLING*

### ***PARTS DEPARTMENT***

*800-427-1244 or 310-537-3700*

*FAX: 800-672-7877 or 310-637-3284*

### ***SERVICE DEPARTMENT***

*800-421-1244*

*FAX: 310-537-4259*

### ***TECHNICAL ASSISTANCE***

*800-478-1244*

*FAX: 310-631-5032*

### ***WARRANTY DEPARTMENT***

*888-661-4279, or 310-661-4279*

*FAX: 310-537-1173*

# MQ SP2 SLAB SAW — TABLE OF CONTENTS

## MQ SP2 STREET PRO SAWS

Proposition 65 Warning .....	2
Here's How To Get Help .....	3
Table Of Contents .....	4
Parts Ordering Procedures .....	5
Specifications .....	6
Dimensions .....	7
Safety Message Alert Symbols .....	8-9
Rules for Safe Operation .....	10-12
Decals .....	13
Major Components .....	14
13 HP Engine Components .....	15
20 HP Engine Components .....	16
General Information .....	17-18
Inspection .....	19-20
Inspection Blade .....	21
Inspection Blade Placement .....	22
Inspection-Guards, Covers, and V-Belts .....	23
Inspection-V-Belts and Water Tank .....	24
Manual Start-up Procedure .....	25-26
Electric Start-up Procedure .....	27
Shutdown Procedures .....	28
Operation .....	29-32
Maintenance .....	33-37
13HP Engine Wiring Diagram .....	38
20HP Engine Wiring Diagram .....	39
Troubleshooting (Engine) .....	40-41
Troubleshooting (Blade) .....	42
Explanation Of Codes In Remarks Column .....	42
Suggested Spare Parts .....	43

## COMPONENT DRAWINGS

Nameplate and Decals .....	44-45
Under Carriage Assembly .....	46-47
Blade Shaft Assembly .....	48-49
Lifting Bale Assembly .....	50-51
Console (Push) Assembly .....	52-53
Console (Self-propelled) Assembly .....	54-55
13 HP Engine Mount Assembly .....	56-57
20 HP Engine Mount Assembly .....	58-59
13 HP Engine Assembly .....	60-61
20 HP Engine Assembly .....	62-63
Pointers And Covers .....	64-65
Water System Assembly .....	66-67
Blade Guard Assembly .....	68-69
Manual Raise and Lower Assy. (20 inch) .....	70-71

## SELF-PROPELLED MODELS ONLY

Battery Assembly .....	72-73
Transmission Engage Lever Assembly .....	74-75
Hydrostatic Transmission Assembly .....	76-77
Hydrostatic Drive Assembly .....	78-79

## HONDA GX390K1QWT2 GASOLINE ENGINE

Air Cleaner Assembly .....	80-81
Camshaft Assembly .....	82-83
Carburetor Assembly .....	84-85
Control Assembly .....	86-87
Crankcase Cover Assembly .....	88-89
Crankshaft Assembly .....	90-91
Cylinder Barrel Assembly .....	92-93
Cylinder Head Assembly .....	94-95
Fan Cover Assembly .....	96-97
Flywheel Assembly .....	98-99
Fuel Tank Assembly .....	100-101
Ignition Coil Assembly .....	102-103
Muffler Assembly .....	104-105
Piston Assembly .....	106-107
Recoil Starter Assembly .....	108-109
Labels .....	110-111

## HONDA GX620TXF2 GASOLINE ENGINE

Air Cleaner Assembly .....	112-113
Camshaft Assembly .....	114-115
Control Assembly .....	116-117
Control Box .....	118-119
Crankcase Cover Assembly .....	120-121
Crankshaft Assembly .....	122-123
Cylinder Barrel Assembly .....	124-125
Cylinder Head Assembly .....	126-127
Fan Cover Assembly .....	128-129
Flywheel Assembly .....	130-131
Ignition Coil Assembly .....	132-133
Muffler Assembly .....	134-135
Piston Assembly .....	136-137
Fuel Tank Assembly .....	138-139
Fuel Pump .....	140-141
Carburetor Assembly .....	142-143
Starter Motor Assembly .....	144-145
Gasket Kit Assembly .....	146-147
Labels .....	148-149

Terms and Conditions of Sale — Parts .....	150
--	-----

www.multiquip.com

**Ordering parts has never been easier!  
Choose from three easy options:**



**Order via Internet (Dealers Only):**

Order parts on-line using Multiquip's SmartEquip website!

- View Parts Diagrams
- Order Parts
- Print Specification Information



If you have an MQ Account, to obtain a Username and Password, E-mail us at: [parts@multiquip.com](mailto:parts@multiquip.com).

To obtain an MQ Account, contact your District Sales Manager for more information.

Goto [www.multiquip.com](http://www.multiquip.com) and click on **Order Parts** to log in and save!

Use the **internet** and qualify for a **5% Discount** on *Standard orders* for all orders which include complete part numbers.\*

Note: Discounts Are Subject To Change



**Order via Fax (Dealers Only):**

All customers are welcome to order parts via Fax.

**Domestic (US) Customers dial:**  
1-800-6-PARTS-7 (800-672-7877)

**Fax** your order in and qualify for a **3% Discount** on *Standard orders* for all orders which include complete part numbers.\*

Note: Discounts Are Subject To Change



**Order via Phone: Domestic (US) Dealers Call:**  
1-800-427-1244

**Non-Dealer Customers:**  
Contact your local Multiquip Dealer for parts or call 800-427-1244 for help in locating a dealer near you.



**International Customers** should contact their local Multiquip Representatives for Parts Ordering information.

**When ordering parts, please supply:**

- |  |  |
|--|--|
| <ul style="list-style-type: none"> <li><input type="checkbox"/> Dealer Account Number</li> <li><input type="checkbox"/> Dealer Name and Address</li> <li><input type="checkbox"/> Shipping Address (if different than billing address)</li> <li><input type="checkbox"/> Return Fax Number</li> <li><input type="checkbox"/> Applicable Model Number</li> <li><input type="checkbox"/> Quantity, Part Number and Description of Each Part</li> </ul> | <ul style="list-style-type: none"> <li><input type="checkbox"/> Specify Preferred Method of Shipment:                     <ul style="list-style-type: none"> <li><input checked="" type="checkbox"/> Fed Ex/UPS      <input checked="" type="checkbox"/> DHL</li> <li><input type="checkbox"/> Priority One      <input checked="" type="checkbox"/> Truck</li> <li><input type="checkbox"/> Ground</li> <li><input type="checkbox"/> Next Day</li> <li><input type="checkbox"/> Second/Third Day</li> </ul> </li> </ul> |
|--|--|

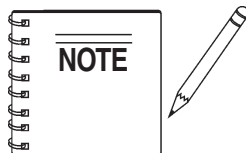

Unless otherwise indicated by customer, all orders are treated as *Standard Orders* and will ship within 24 hours. We will make every effort to ship *Air Shipments* the same day the order is received, if received prior to 2PM PST. *Stock Orders* must be noted on fax or web order form.

**WE ACCEPT ALL MAJOR CREDIT CARDS!**



# MQ SP2 SLAB SAW — SPECIFICATIONS

## TABLE 1. SAW SPECIFICATIONS

	SP2 (Push)	SP2 (Self-Propelled)	
<b>Saw</b>	SP213H20	SP2S13H20	SP2S20H20
<b>Blade Capacity in. (mm)</b>	20 in. (508 mm)		
<b>Cutting Depth in. (mm)</b>	7.5 in. (191 mm)		
<b>Front Wheels in.(mm)</b>	5 in. Dia. x 2 in. Wide (125mm x 50mm)		
<b>Rear Wheels in.(mm)</b>	8 in. Dia. x 2 in. Wide (125mm x 50mm)		
<b>Weight lbs.(kg)</b>	280 lbs. (127kg)	280 lbs. (127kg)	400 lbs. (181.8kg)
<b>Engine</b>	Honda 13HP GX390K1QWT2 Gasoline Engine		Honda 20HP GX620TXF2 Gasoline Engine

## TABLE 2. ENGINE SPECIFICATIONS

Engine Model	Honda GX390K1QWT2	Honda GX620TXF2
<b>Engine Type</b>	Air-cooled 4-Stroke Single Cylinder OHV Horizontal Shaft Engine	Air-cooled 4-Stroke OHV 90° V-Twin; Horizontal Shaft
<b>Bore x Stroke</b>	3.5 in. x 2.5 in. (88 mm x 64 mm)	3.0 x 2.6 in (77 x 66 mm)
<b>Displacement</b>	23.7 cu. in. (389 cc.)	37.4 cu. in. (614 cc.)
<b>Maximum Power Output</b>	13 HP / 3,600 rpm	20 HP / 3,600 rpm
<b>Maximum Torque</b>	19.5 ft-lbs (2,500 rpm) 2.7 kg-m (2,500 rpm)	32.5 ft-lbs (2,500 rpm) 4.50 kgf-m (2,500 rpm)
<b>Idle Speed</b>	1,400 ± 150 rpm	1,400 ± 150 rpm
<b>Maximum No Load RPM</b>	3,600 ± 100 rpm	3,600 ± 100 rpm
<b>Specific Fuel Consumption</b>	1 gal./hr. (20.81 liters/hr.)	1.54 gals./hr. (5.82/liters/hr.)
<b>Fuel Tank Capacity</b>	1.72 gallons (6.5 liters)	2.20 gallons (8.32 liters)
<b>Crankcase Oil Capacity</b>	2.32 pints (1.1 liters)	3.18 pints (1.50 liters)
<b>Starting System</b>	Recoil Start	Electric Start
<b>Spark Plug Gap</b>	.028 - .031 in. (0.70 - 0.78 mm.)	.028 - .031 in. (0.70 - 0.78 mm.)
<b>Air Cleaner</b>	Cyclone Type	Dual Element
<b>Dry Weight</b>	68.4 lbs. (31 kg)	92.6 lbs (42 kg)
<b>Dimensions (LxWxH)</b>	15.0 x 17.7 x 17.4 in. (380 x 450 x 443 mm)	15.3 x 18 x 17.8 in. (388 x 457 x 452 mm)

# MQ SP2 SLAB SAW — DIMENSIONS

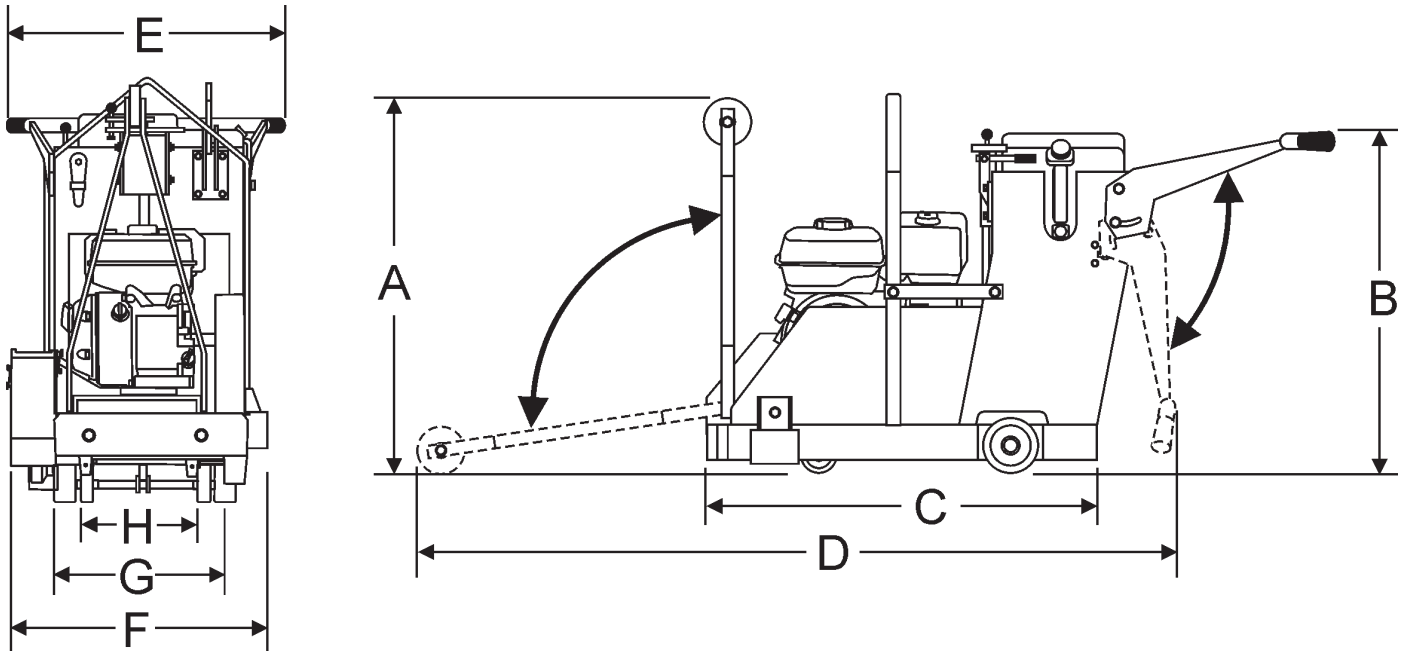

Figure 1. SP2 Dimensions

TABLE 3. DIMENSIONS

REFERENCE LETTER	DESCRIPTION	DIMENSIONS IN. (MM)
A	Max Height (Handle Bars fully lowered & Front Pointer raised)	36 in. (914 mm.)
B	Max Handle Bar Height (fully raised)	40 in. (1016 mm.)
C	Max Length (Handle Bars & Front Pointer fully raised)	43 in. (1092 mm.)
D	Max Length (Handle Bars fully raised & Front Pointer lowered)	68 in. (1727 mm.)
E	Max Handle Bar Width	24 in. (610 mm.)
F	Max Width	24.5 in. (622 mm.)
G	Rear Wheel Base	16 in. (406 mm.)
H	Front Wheel Base	14 in. (356 mm.)
<b>Crated Dimension (L x W x H): 47 x 30 x 44 in. (1194 x 762 x 1118 mm)</b>		

# MQ SP2 SLAB SAW — SAFETY MESSAGE ALERT SYMBOLS

## FOR YOUR SAFETY AND THE SAFETY OF OTHERS!

Safety precautions should be followed at all times when operating this equipment. Failure to read and understand the Safety Messages and Operating Instructions could result in injury to yourself and others.

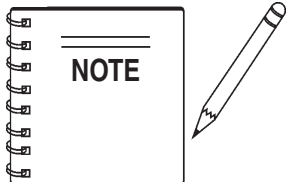

This Owner's Manual has been developed to provide complete instructions for the safe and efficient operation of the MQ SP2 Series Slab Saws. Depending on the power plant you have selected, please refer to the

engine manufacturers instructions for data relative to its safe operations.

**Before using any of the MQ Series Slab Saws, ensure that the operating individual has read and understands all instructions in this manual.**

## SAFETY MESSAGE ALERT SYMBOLS

The three (3) Safety Messages shown below will inform you about potential hazards that could injure you or others. The Safety Messages specifically address the level of exposure to the operator, and are preceded by one of three words: **DANGER**, **WARNING**, or **CAUTION**.

### **DANGER**

You **WILL** be **KILLED** or **SERIOUSLY INJURED** if you **DO NOT** follow these directions.

### **WARNING**

You **CAN** be **KILLED** or **SERIOUSLY INJURED** if you **DO NOT** follow these directions.

### **CAUTION**

You **CAN** be **INJURED** if you **DO NOT** follow these directions.

Potential hazards associated with MQ SP2 Series Slab Saw operation will be referenced with Hazard Symbols which appear throughout this manual, and will be referenced in conjunction with Safety Message Alert Symbols.

## HAZARD SYMBOLS

### **Lethal Exhaust Gases**



Engine exhaust gases contain poisonous carbon monoxide. This gas is colorless and odorless, and can cause death if inhaled. **NEVER** operate this equipment in a confined area or enclosed structure that does not provide ample free flow air.

### **Explosive Fuel**



Gasoline is extremely flammable, and its vapors can cause an explosion if ignited. **DO NOT** start the engine near spilled fuel or combustible fluids. **DO NOT** fill the fuel tank while the engine is running or hot. **DO NOT** overfill tank, since spilled fuel could ignite if it comes into contact with hot engine parts or sparks from the ignition system. Store fuel in approved containers, in well-ventilated areas and away from sparks and flames. **NEVER** use fuel as a cleaning agent.

### **Burn Hazards**



Engine components can generate extreme heat. To prevent burns, **DO NOT** touch these areas while the engine is running or immediately after operations. **NEVER** operate the engine with heat shields or heat guards removed.

### **Rotating Parts**



**NEVER** operate equipment with covers, or guards removed. Keep fingers, hands, hair and clothing away from all moving parts to prevent injury.



# MQ SP2 SLAB SAW — SAFETY MESSAGE ALERT SYMBOLS



## Accidental Starting



**OFF** **ALWAYS** place the **ON/OFF** switch in the **OFF** position, remove key and/or disconnect the spark plug lead before servicing the engine or equipment. Ground the lead to prevent sparks that could ignite a fire.



## Respiratory Hazard



**ALWAYS** wear approved respiratory protection.



## Over Speed Conditions



**NEVER** tamper with the factory settings of the engine governor or settings. Personal injury and damage to the engine or equipment can result if operating in speed ranges above maximum allowable.



## Sight and Hearing hazard

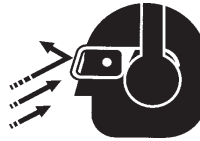

**ALWAYS** wear approved eye and hearing protection.



## Guards and Covers In Place



**NEVER** operate the saw without blade guards and covers in place. Adhere to safety guidelines ANSI American National Standards Institute, OSHA or other applicable local regulations.



## Equipment Damage Messages

Other important messages are provided throughout this manual to help prevent damage to your slab saw, other property, or the surrounding environment.

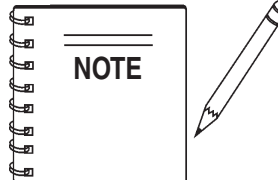

This slab saw, other property, or the surrounding environment could be damaged if you **DO NOT** follow instructions.

# MQ SP2 SLAB SAW — RULES FOR SAFE OPERATION

## RULES FOR SAFE OPERATION

### CAUTION

Failure to follow instructions in this manual may lead to serious injury or even death! This equipment is to be operated by trained and qualified personnel only! This equipment is for industrial use only.

The following safety guidelines should always be used when operating the MQ SP2 Slab Saw.

### SAFETY

- **DO NOT** operate or service this equipment before reading this entire manual.
- This equipment should not be operated by persons under 18 years of age.
- **NEVER** operate the saw without proper protective clothing, shatterproof glasses, steel-toed boots and other protective devices required by the job.



- **NEVER** operate this equipment when not feeling well due to fatigue, illness or taking medicine.



- **NEVER** operate the saw under the influence of drugs or alcohol.



- **NEVER** use accessories or attachments, which are not recommended by or Multiquip for this equipment. Damage to the equipment and/or injury to user may result.
- Manufacturer does not assume responsibility for any accident due to equipment modifications. Unauthorized equipment modification will void all warranties.
- Whenever necessary, replace nameplate, operation and safety decals when they become difficult read.
- **ALWAYS** check the saw for loosened hardware such as nuts and bolts before starting.

- **NEVER** touch the hot exhaust manifold, muffler or cylinder. Allow these parts to cool before servicing the saw.



- **High Temperatures** – Allow the engine to cool before adding fuel or performing service and maintenance functions. Contact with **hot!** components can cause serious burns.
- The engine of this saw requires an adequate free flow of cooling air. **NEVER** operate the saw in any enclosed or narrow area where free flow of the air is restricted. If the air flow is restricted it will cause serious damage to the saw's engine and may cause injury to people. Remember the saw's engine gives off **DEADLY** carbon monoxide gas.

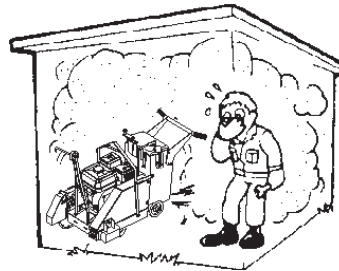

- **ALWAYS** refuel in a well-ventilated area, away from sparks and open flames.

- **ALWAYS** use extreme caution when working with **flammable** liquids. When refueling, **STOP** the engine and allow it to cool.

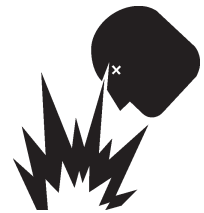

- **NEVER** smoke around or near the machine. Fire or explosion could result from **fuel vapors**, or if fuel is spilled on a **hot!** engine.



- **NEVER** operate the saw in an explosive atmosphere where fumes are present or near combustible materials. An explosion or fire could result causing severe **bodily harm or even death**.
- Topping-off to filler port is dangerous, as it tends to spill fuel.
- **NEVER** use fuel as a cleaning agent.

# MQ SP2 SLAB SAW — RULES FOR SAFE OPERATION

## General Safety

- **ALWAYS** read, understand, and follow procedures in Operator's Manual before attempting to operate equipment.
- **ALWAYS** be sure the operator is familiar with proper safety precautions and operating techniques before using the saw.
- **NEVER** leave the machine *unattended* while running.
- Block the unit when leaving or when using on a slope.
- **ALWAYS** check to make sure that the operating area is clear before starting the engine.
- Maintain this equipment in a safe operating condition at all times.
- **ALWAYS** stop the engine before servicing, adding fuel and oil.
- **NEVER** run the engine without the air filter. Severe engine damage could occur.
- **ALWAYS** service air cleaner frequently to prevent carburetor malfunction.
- **AVOID** wearing jewelry or loose fitting clothing that may snag on the controls or moving parts, this can cause a serious injury.
- **ALWAYS** keep clear of *rotating* or *moving parts* while the saw is in operation.
- **ALWAYS** store equipment properly when it is not being used. Equipment should be stored in a clean, dry location out of the reach of children.
- **NEVER** use accessories or attachments which are not recommended by the manufacturer for this equipment. Damage to the equipment and/or injury to user may result.
- Keep all inexperienced and unauthorized people away from the equipment at all times.

## **WARNING**

**ALWAYS** check to make sure that the operating area is clear before starting the engine.

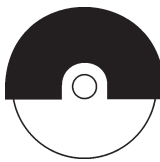

## Diamond Blade Safety

- Use appropriate steel centered diamond blades manufactured for use on slab saws.
- Examine blade flanges for damage, excessive wear and cleanliness before mounting blade. Blade should fit snugly on the shaft and against the inside/outside blade flanges.
- Ensure the blade is marked with an operating speed greater than the blade shaft speed of the saw.

## **WARNING**

**ALWAYS** inspect diamond blades before each use. The blade should exhibit no cracks, dings, or flaws in the steel centered core and/or rim. Center (arbor) hole must be undamaged and true.



- Only cut the material that is specified by the diamond blade. Read the specifications of the diamond blade to ensure the proper tool has been matched to the material being cut.
- **ALWAYS** keep blade guards in place. Exposure of the diamond blade must not exceed 180 degrees.
- Ensure that the diamond blade does not come into contact with the ground or surface during transportation. **DO NOT** drop the diamond blade on ground or surface.
- The engine governor is designed to permit maximum engine speed in a no-load condition. Speeds that exceed this limit may cause the diamond blade to exceed the maximum safe allowable speed.
- Ensure that the blade is mounted for proper operating direction.

# MQ SP2 SLAB SAW — RULES FOR SAFE OPERATION

## Maintenance Safety

- **NEVER** lubricate components or attempt service on a running machine.
- **ALWAYS** allow the machine a proper amount of time to cool before servicing.
- Keep the machinery in proper running condition.
- Fix damage to the machine immediately and **ALWAYS** replace broken parts.
- Dispose of hazardous waste properly. Examples of potentially hazardous waste are used motor oil, fuel and fuel filters.
- **DO NOT** use food or plastic containers to dispose of hazardous waste.

## Saw Transportation Safety

- Use appropriate lifting equipment to ensure the safe movement of the saw.
- **DO NOT** use the handle bars and/or front pointer as lifting points.
- When transporting of the saw is required, place saw directly inside towing vehicle truck-bed and tie-down securely. **NEVER** tow saw directly behind towing vehicle.
- **DO NOT** use the saw on slopes or on extremely un-level surfaces. An engine tipped to extreme angles may cause oil to gravitate into the cylinder head making the engine start difficult.
- **NEVER** transport the saw with the blade mounted.

## Emergencies

- **ALWAYS** know the location of the nearest **fire extinguisher**.



- **ALWAYS** know the location of the nearest **first aid kit**.



- In emergencies **ALWAYS** know the location of the nearest phone or **keep a phone on the job site**. Also know the phone numbers of the nearest **ambulance**, **doctor** and **fire department**. This information will be invaluable in the case of an emergency.



# MQ SP2 SLAB SAW — DECALS

## Machine Safety Decals

The SP2 series slab saws are equipped with a number of safety decals (Figure 2). These decals are provided for operator safety and maintenance information. The illustration below shows these decals as they appear on the slab saws. Should any of these decals become unreadable, replacements can be obtained from your dealer. See the "Nameplate and Decals" section for decal placement.

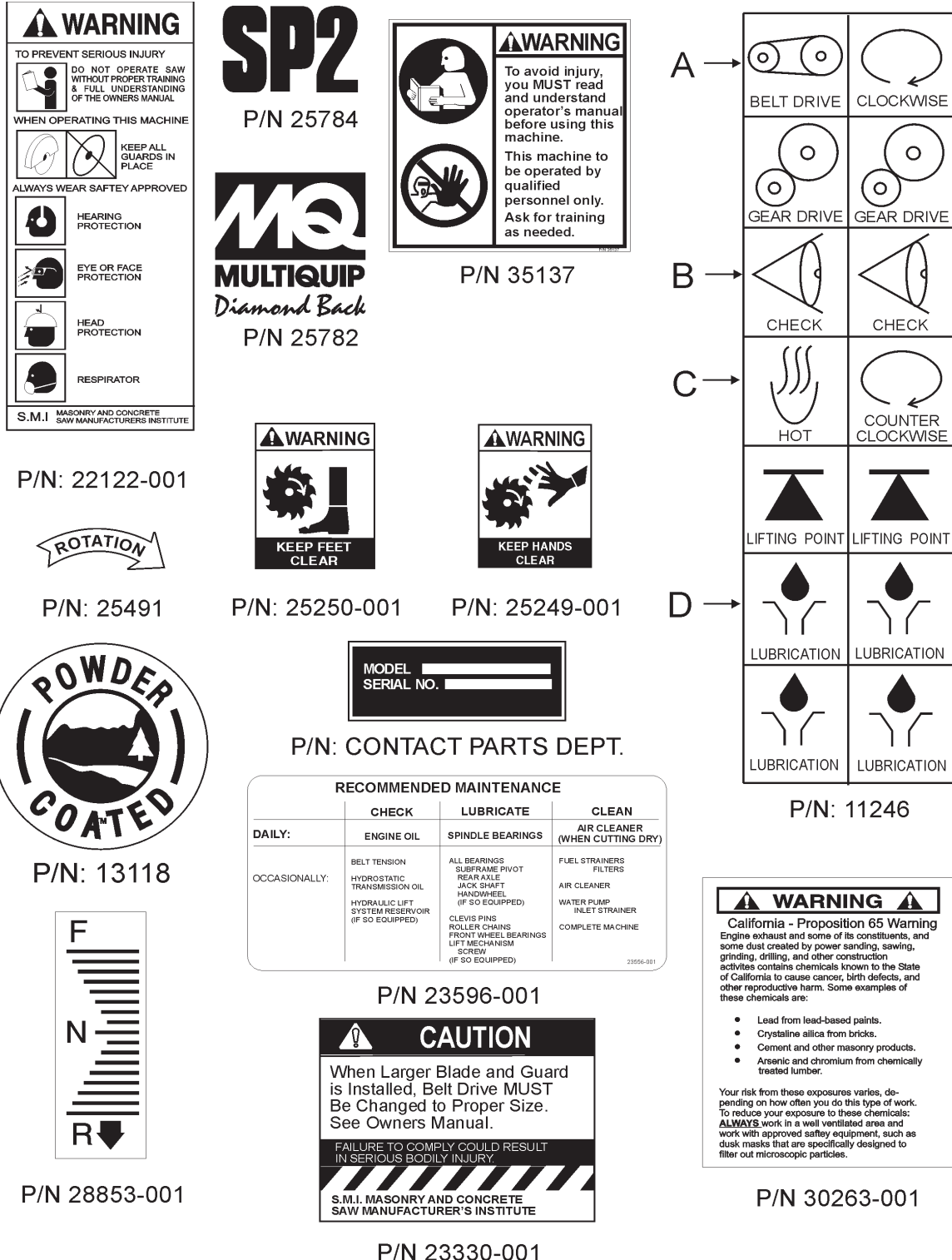
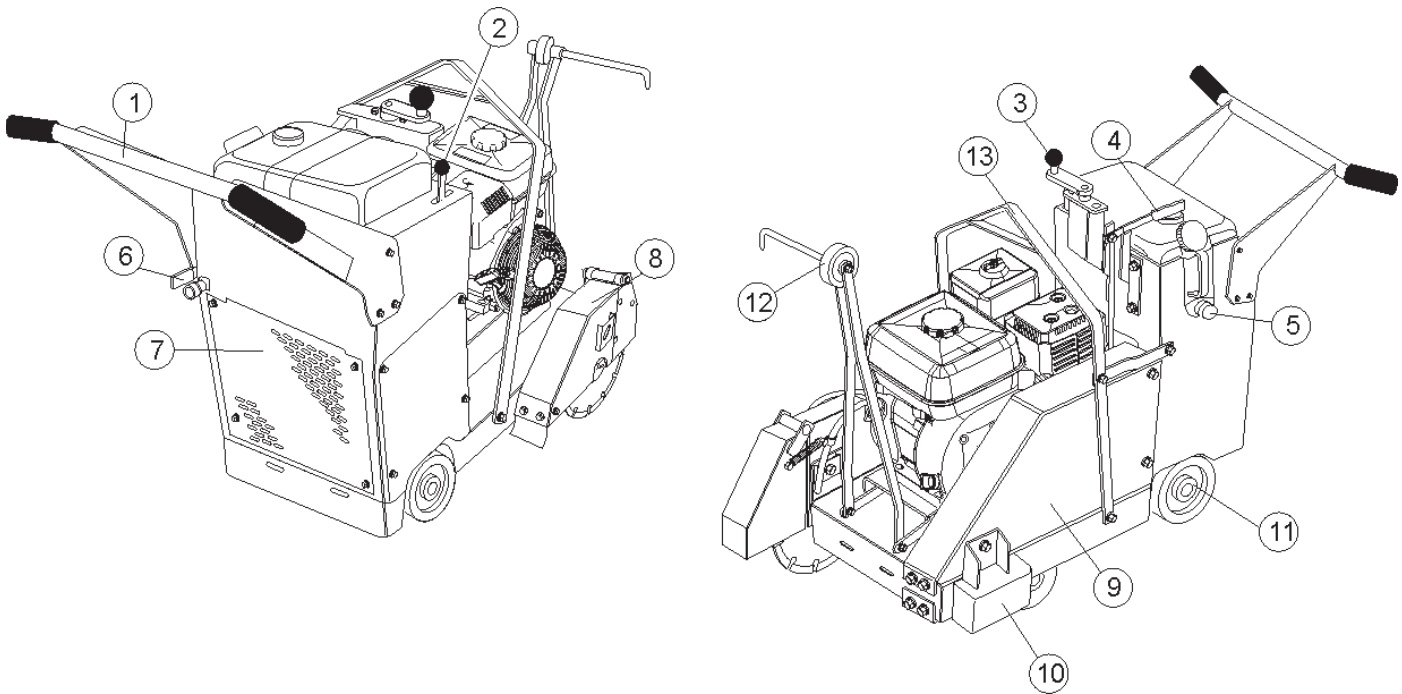

Figure 2. MQ SP2 Slab Saw Decals

# MQ SP2 SLAB SAW — MAJOR COMPONENTS



**Figure 3. SP2 Saw Major Components**

Figure 3 displays the location of the various operational control features of the MQ SP2 slab saw. Features are dependent on the specific model saw selected. The function of each console component or indicator is explained below:

1. **Handle Bars** – Used to steer and push the SP2 slab saw during cutting operations. The handle can be folded down for transportation.
2. **Forward/Reverse Speed Lever** – Controls forward and reverse speeds for self-propelled operation. Provides positive neutral for engine start. **ALWAYS** place transmission engage/disengage lever in the engage position before setting speed lever (self-propelled models only).
3. **Raise/Lower Crank Handle** – Physically orients saw (raises or lowers) depending on cranking direction (CW or CCW). Turning the handle **clockwise** lowers the saw, turning the saw counter-clockwise raises the saw.
4. **Transmission Engage/Disengage Lever** – Forward locking position engages transmission. Rear Locking position disengages transmission from rear axle and permits "free wheeling" (self-propelled models only).
5. **Water Tank** – A 5-gallon capacity water tank provides water for the saw blade during wet cutting applications.
6. **Water ON/OFF Valve** – **ON** position **opens** valve and permits water to flow from source through saw water hose. **OFF** position **closes** valve and halts the flow of water.
7. **Hydraulic Drive Transmission** - Controls the saw's forward and reverse movement by using the **forward/reverse speed lever** (Self-propelled units only).
8. **Saw Blade Guard** – Covers the saw blade during cutting operations & allows water hoses to be connected to the cover for wet cutting.
9. **Belt Cover** – Covers the drive shaft belt, engine pulley and the hydraulic transmission belt (on self-propelled models only).
10. **Drive-Shaft Pulley Guard** – Covers the drive shaft pulley.
11. **Rear Wheels** – Allows the saw to be rolled across ground. On self-propelled models, the rear wheels are turned by the spline gears attached to the hydraulic transmission system.
12. **Pointer Arm** – Front pointer wheel assists in straight tracking. Lifts up for storage and pivots down for use.
13. **Lifting Bale Kit** – Allows for easy lifting and transporting the MQ SP2 slab saw.

# MQ SP2 SLAB SAW — 13HP HONDA ENGINE COMPONENTS

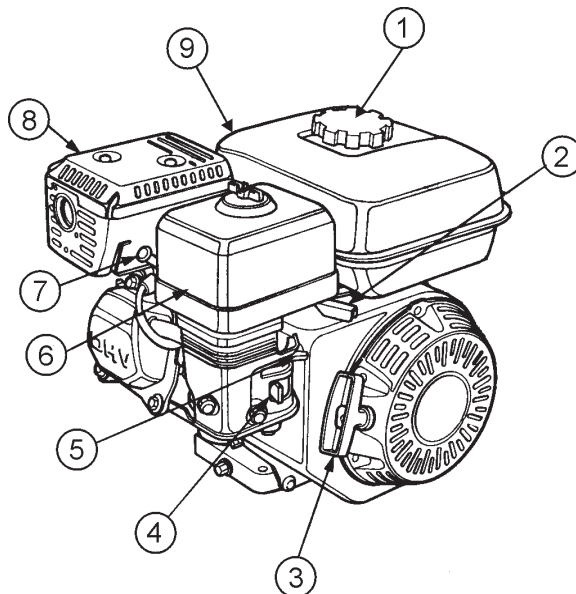

Figure 4. Engine Controls and Components (Honda GX390K1QWT2)

## INITIAL SERVICING

The engine (Figure 4) must be checked for proper lubrication and filled with fuel prior to operation. Refer to the manufacturers Engine manual for instructions & details of operation and servicing.

1. **Fuel Filler Cap** – Remove this cap to add unleaded gasoline to the fuel tank. Make sure cap is tightened securely. **DO NOT** over fill.

### **WARNING**

Adding fuel to the tank should be accomplished only when the engine is stopped and has had an opportunity to cool down. In the event of a fuel spill, **DO NOT** attempt to start the engine until the fuel residue has been completely wiped up, and the area surrounding the engine is dry.

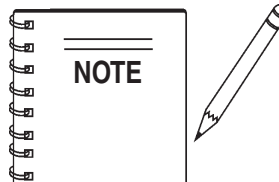

Operating the engine without an air filter, with a damaged air filter, or a filter in need of replacement will allow dirt to enter the engine, causing rapid engine wear.

2. **Throttle Lever** – Used to adjust engine RPM speed (lever advanced forward **SLOW**, lever back toward operator **FAST**).
3. **Recoil Starter (pull rope)** – Manual-starting method. Pull the starter grip until resistance is felt, then pull briskly and smoothly.
4. **Fuel Valve Lever** – **OPEN** to let fuel flow, **CLOSE** to stop the flow of fuel.
5. **Choke Lever** – Used in the starting of a cold engine, or in cold weather conditions. The choke enriches the fuel mixture.
6. **Air Cleaner** – Prevents dirt and other debris from entering the fuel system. Remove wing-nut on top of air filter cannister to gain access to filter element.

7. **Spark Plug** – Provides spark to the ignition system. Set spark plug gap (HONDA) to 0.6 - 0.7 mm (0.028 - 0.031 inch). Clean spark plug once a week.
8. **Muffler** – Used to reduce noise and emissions. Engine components can generate extreme heat. To prevent burns, **DO NOT** touch these areas while the engine is running or immediately after operating. **NEVER** operate the engine with the muffler removed.

### **WARNING**

Engine components can generate extreme heat. To prevent burns, **DO NOT** touch these areas while the engine is running or immediately after operating. **NEVER** operate the engine with the muffler removed.



9. **Fuel Tank** – Holds unleaded gasoline. For additional information refer to engine owner's manual.

# MQ SP2 SLAB SAW — 20HP HONDA ENGINE COMPONENTS

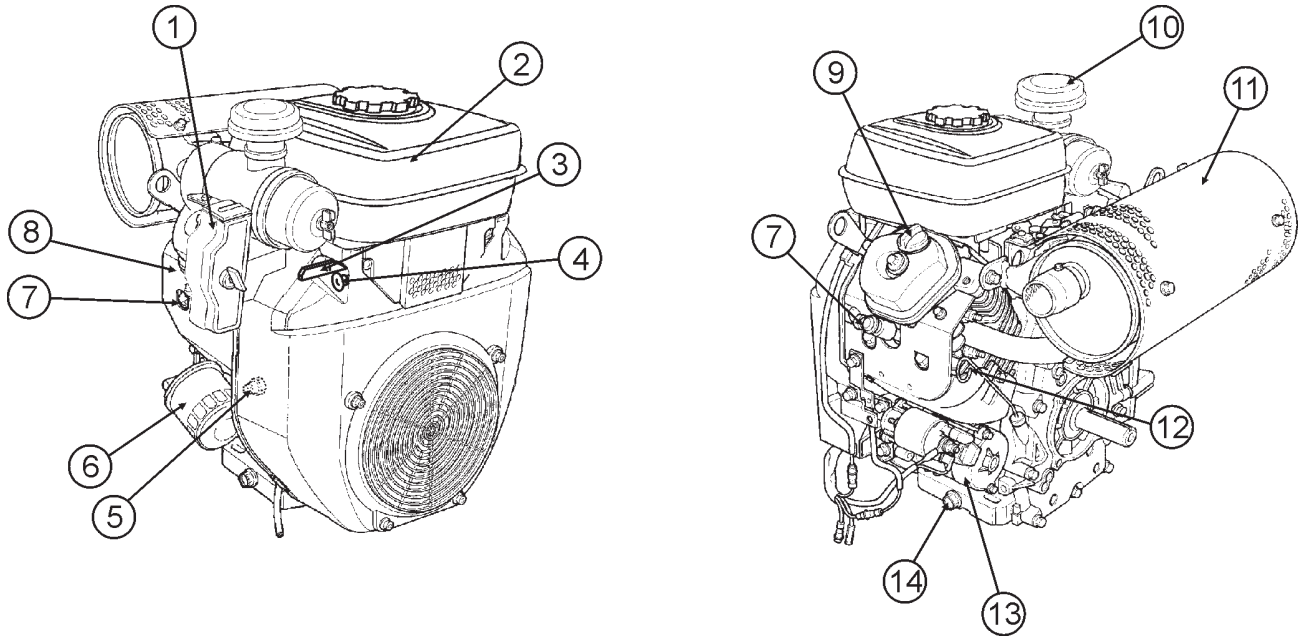

Figure 5. Engine Controls and Components (Honda GX620TXF2)

## INITIAL SERVICING

The engine (Figure 5) must be checked for proper lubrication and filled with fuel prior to operation. Refer to the manufacturer's engine manual for instructions & details of operation and servicing.

1. **Engine ON/OFF Switch** – ON position permits engine starting, OFF position stops engine operations.
2. **Fuel Tank** - Holds unleaded gasoline. For additional information refer to engine owner's manual.
3. **Throttle Lever** – Controlled by accelerator pedal, increases or decreases engine RPM.
4. **Choke Knob** – Used in the starting of a cold engine or in cold weather conditions. The choke enriches the fuel mixture.
5. **Oil Sensor Switch** – This switch monitors the oil level in the engine crankcase. In the event of low oil, the engine will be shut down.
6. **Oil Filter** – Spin-on type, filters oil for contaminants.
7. **Spark Plug** – Provides spark to the ignition system. Set spark plug gap to 0.71 - 0.78 mm (0.028 - 0.031 inch) Clean spark plug once a week.
8. **Fuel Filter** – Filters fuel for contaminants.
9. **Oil Filler Cap** – Remove cap to refill or replace oil with recommended type as listed in Table 3. Make sure cap is tightened securely. **DO NOT** over fill.
10. **Air Filter** – Prevents dirt and other debris from entering the fuel system. Unsnap air filter cover to gain access to filter element.
11. **Muffler** –Used to reduce noise and emissions. **NEVER** touch the muffler while it is hot! Serious burns can result. **NEVER** operate the engine with the muffler removed.
12. **Oil Dip Stick** – Remove to check amount and condition of oil in crankcase.
13. **Starter** – Starts engine when ignition key is rotated to the ON position.
14. **Oil Drain Plug** – Remove to drain crankcase oil.

### **WARNING**

Engine components can generate extreme heat. To prevent burns, **DO NOT** touch these areas while the engine is running or immediately after operating. **NEVER** operate the engine with the muffler removed.





# MQ SP2 SLAB SAW — GENERAL INFORMATION

## Familiarization

The SP2 series **slab saws** are designed for **wet** or **dry** cutting of concrete or asphalt utilizing diamond blades. They have been engineered for general, industrial and high production flat cutting applications. The reinforced steel box frame design adds strength necessary to reduce vibrations while cutting. Minimizing vibrations enhances the performance of the blade and extends the life of the saw.

Heavy-duty front and rear axles, sturdy oversized wheels and industrial undercarriage assembly ensures accurate tracking and years of reliable use.

Additionally, the general weight-to-strength ratio design of the frame and chassis assembly provides optimum weight distribution to keep the blade running true in the cut. A rugged blade shaft bearing assembly ensures minimal flutter and shaft harmonics providing the most advantageous condition for a diamond blade at operating speeds.

## Power Plants

The SP2 series slab saws are generally classified in the industry as **LOW** to **MEDIUM** horsepower saws. This classification is particularly useful when selecting the proper diamond blade for an application.

There are two gasoline engines used with the SP2 series saws: A **13 HP Honda GX390K1QWT2** air-cooled, 4-stroke single cylinder, OVH rated at 3600 RPM and a **20HP Honda GX620TXF2** air-cooled, 4-stroke OVH 90° V-twin rated at 3600 RPM. Blade rotation is v-belt driven. This is accomplished by connecting to the output shaft of the engine to an upper drive pulley. The lower drive pulley (Blade) is then connected to the upper drive pulley (Engine) by three V-belts. As the engine shaft rotates, so does the blade.

Refer to the engines Owner's Manual for the specific instructions regarding engine operation and maintenance practices.

## Console

An ergonomically designed control console allows the operator to easily understand and/or operate the adjustable handlebars, **Raise/Lower Crank Handle**, and **transmission engage/disengage lever** (Self-propelled models only). Additionally, for self-propelled models, the console also provides forward/reverse controls.

## Manual Raise/Lower System

The SP2 slab saw uses an ACME thread, manual raise/lower assembly easily raises and lowers the blade and can lock into position to ensure a constant depth when cutting. See Table 6 for blade selection with respect to depth of cut.

## Water System

All saws provide a water direction system to provide cooling water to the diamond blade. This system consists of: a standard "garden hose" valve that connects to the water source (via hose) to the saw, an **ON/OFF** console water valve'

The 20-inch blade guard is designed with two 6-inch vinyl water tubes to direct water to the diamond blade.

## Under Carriage System

A jig welded heavy steel gauge under carriage assembly supports the saw in tracking, pivoting and stabilization. A rear axle supports two solid rubber cast hub wheels with roller bearings, grease fittings and locking collars. A front axle supports two solid rubber cast hub wheels with roller bearings, grease fittings and locking collars. The assembly pivots about two rocker blocks with bushings.

## Blade Drive System

A rugged blade shaft assembly has been specifically designed to support the optimum distribution of torque from the engine shaft to the blade shaft, and to ensure minimal vibratory conditions on the tips of the shaft.

Balanced engine & blade shaft pulleys are connected to their respective shafts, 3 V-belts (13HP, 4 V-belts for 20HP models) connect to the engine pulley to the blade shaft pulley. The blade shaft is supported by two self-aligning pillow block bearings that are uniquely positioned on the most outboard portion of the reinforced frame.

The combination of pulley and blade shaft bearing positioning ensures minimal vibration & flutter to the ends of the blade shaft.

## Water System

The MQ SP2 slab saw comes standard with a 20-inch hinged two piece, heavy steel gauge blade guard. The blade guard provides access for vinyl water tubes that supply optimum volume and dispersal of water for cooling and/or dust suppression.

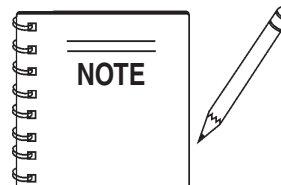

All MQ series SP2 slab saws are designed, engineered and manufactured with strict adherence to American National Standards Institute, Inc. (ANSI) guidelines B7.1 and B7.5

# MQ SP2 SLAB SAW — INSPECTION

## Before Starting

1. Read safety instructions at the beginning of manual.
2. Clean the saw, removing dirt and dust, particularly the engine cooling air inlet, carburetor and air cleaner.
3. Check the air filter for dirt and dust. If air filter is dirty, replace air filter with a new one as required.
4. Check carburetor for external dirt and dust. Clean with dry compressed air.
5. Check fastening nuts and bolts for tightness.

3. Insert and remove the dipstick without screwing it into the filler neck. Check the oil level shown on the dipstick.
4. If the oil level is low (Figures 6 and 7), fill to the edge of the oil filler hole with the recommended oil type (Table 4). Maximum oil capacity for the Honda GX390 engine is 2.32 pints (1.1 liters) and for the Honda GX620 engine it is 3.18 pints (1.50 liters).

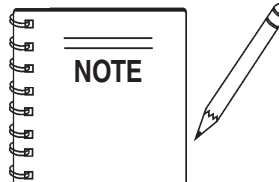

Reference manufacturer engine manual for specific servicing instructions.

## Engine Oil Check

1. To check the engine oil level, place the saw on secure level ground with the engine stopped, and the diamond blade removed.
2. Remove the **filler cap/dipstick** from the engine oil filler hole (Figure 6) and wipe it clean.

HONDA 13 HP engine shown.

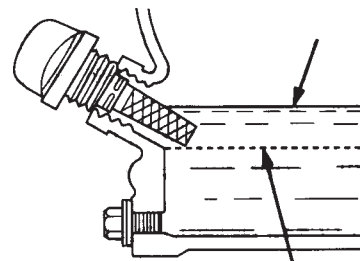
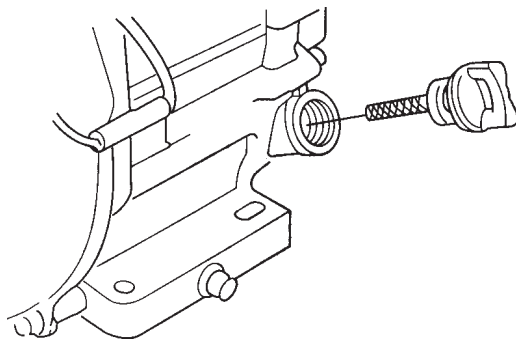
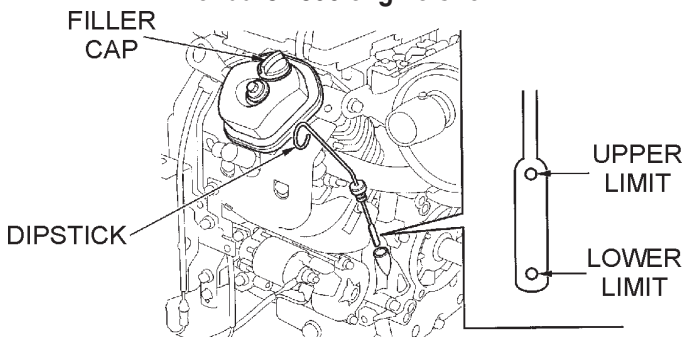

Figure 7. Engine Oil Dipstick (Oil Level)



Honda GX390 engine shown



Honda GX620 engine shown

Figure 6. Engine Oil Dipstick (Removal)

Table 4. Oil Type

Season	Temperature	Oil Type
Summer	25°C or Higher	SAE 10W-30
Spring/Fall	25°C~10°C	SAE 10W-30/20
Winter	0°C or Lower	SAE 10W-10



## Gasoline Check



1. Remove the gasoline cap located on top of fuel tank.
2. Visually inspect to see if fuel level is low. If fuel is low, replenish with unleaded fuel.
3. When refueling, be sure to use a strainer for filtration. **DO NOT** top-off fuel. Wipe up any spilled fuel.

**Hydrostatic Transmission (Self-Propelled models only) -** An EATON® Model 7 hydrostatic transmission (Figure 8) provides the power for the saw's propulsion system. The transmission drives a sprocket that directly connects the spline drive to the rear wheels. The **no load** forward/reverse speeds are approximately 80 ft/min.

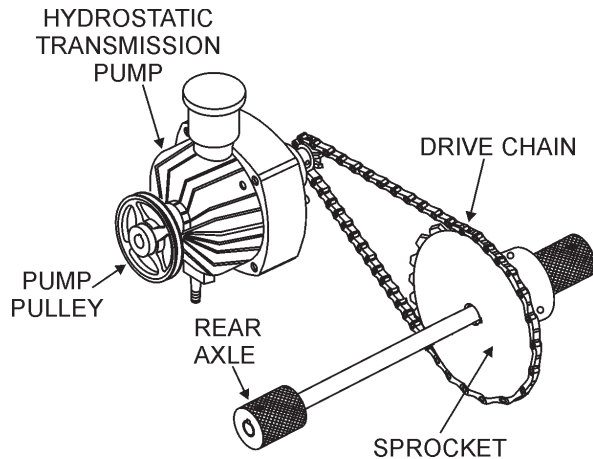

**Figure 8. Hydrostatic Transmission**

The transmission is factory filled with approved hydraulic fluid that has a viscosity equivalent to SAE 20W-20. Should additional servicing be required, the following hydraulic fluids are recommended:

- General Motors Dextron B
- Ford MM2C-33F
- Ford M2C-41A
- International harvester Hy-Tran Fluids

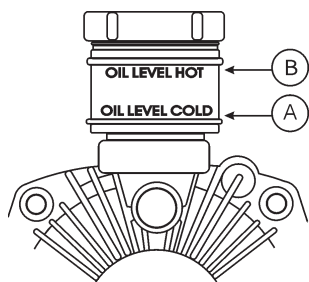
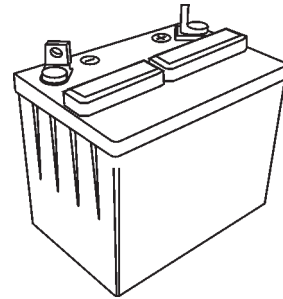

**Figure 9. Transmission Reservoir**

## CAUTION

**DO NOT** over fill the fluid reservoir (Figure 10). Note the level marks on the reservoir. **It is essential to reference the existing oil conditions (A) cold or (B) hot prior to operating the saw.** Overfilling the transmission with hydraulic fluid may cause the seals to **rupture** causing mechanical damage.

**Battery (Self-Propelled models only) -** The 12-volt DC battery (Figure 10) is shipped **dry**, and will require a proper electrolyte level for operation.



**Figure 10. Battery**

When servicing of the battery is required perform the following:

- A face shield and rubber gloves should be worn while handling and servicing battery's electrolyte.
- **Disconnect** battery terminal clamps, and remove the battery from the saw when servicing is required.
- **DO NOT** overfill the battery.

## WARNING

Electrolyte is an acid and must be handled with caution. Servicing instructions from the electrolyte manufacturer must **ALWAYS** be followed to ensure safety. Serious injury can result from careless handling and noncompliance to safety handling instructions.



Overfilling the battery may cause the electrolyte to overflow resulting in corrosion to nearby components. Immediately wash off any spilled electrolyte (battery acid).

Additionally, when connecting the positive (+) cable to the battery's positive (+) terminal post, **DO NOT** allow contact of the wrench or any metallic part to come in contact with the battery's negative (-) terminal post. This may result in an electrical short circuit or an explosion.

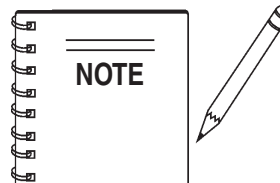

Use only **distilled** water in the battery. Tap water can **reduce** the operating life of the battery.

## MQ SP2 SLAB SAW — INSPECTION -BLADE

### **WARNING**

Failure to thoroughly inspect the diamond blade (Figure 11) for operational safety could result in damage to the blade, the saw, and may cause injury to the user or others in the operating area.

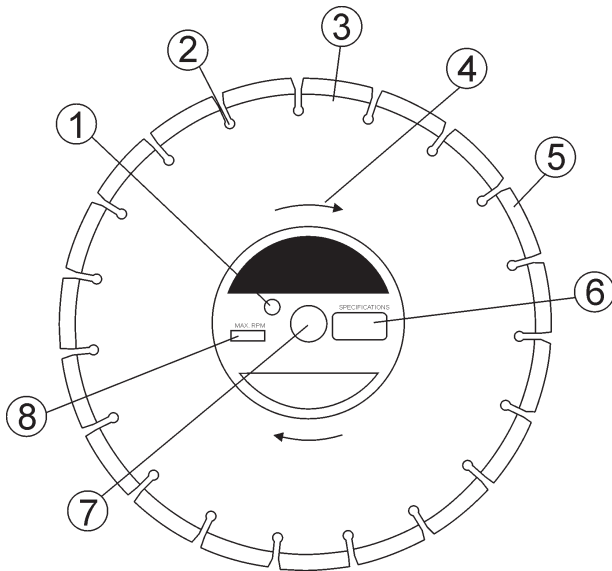

**Figure 11. Diamond Blade**

- 1. Drive Pin Hole** – A commonly located hole on the diamond blade core that prevents operational blade slippage between the inner & outer blade flanges (collars). Inspect the diameter of the hole to ensure there is no distortion, and that a snug fit develops between the hole and drive pin.
- 2. Stress Relief Holes (Gullets)** – Check the steel core for cracks that may have propagated from the slots and/or gullets. Cracks indicate extreme fatigue failure and if sawing continues, catastrophic failure will occur.
- 3. Edge Of The Steel Core** – Check the diameter edge for discoloration (blue oxidation) indicating an overheating condition caused by insufficient cooling water/air. Overheating of blades may lead to loss of core tension and/or increase the possibility for blade failure. Check to make sure the steel core's width is uniform about the rim of the blade, and not succumbing to an "under cutting" condition brought about by highly abrasive material or improper under cutting core protection.
- 4. Directional Arrow** – Check to ensure that the blade is oriented properly on the blade shaft for sawing. Reference the directional arrow in the blade and place it so the direction of rotation "downcuts" with the turn of the shaft.
- 5. Diamond Segment or Rim** – Ensure there are no cracks, dings, or missing portions of the diamond segment/rim. **DO NOT use a blade that is missing a segment or a portion of the rim.** Damaged and/or missing segments/rims may cause damage to your saw, and injury to the user or others in the operating area.
- 6. Specifications** – Ensure that the blade specifications, size, and diameter properly match up to the sawing operation. Wet blades must have water to act as a coolant. Utilizing a diamond blade not matched properly to the task may result in poor performance and/or blade damage.
- 7. Arbor Hole** – It is essential that the arbor hole diameter properly matches the blade, and that it is free from distortions. Correct blade flanges (collars) must be used. The inside face of the flanges must be clean & free of debris. An out of round arbor condition will cause damage to the blade and the saw.
- 8. MAX RPM** – This RPM reference is the maximum safe operating speed for the blade selected. **NEVER** exceed the max RPM on the diamond blade. Exceeding the MAX RPM is dangerous, and may cause poor performance and may damage the blade.

# MQ SP2 SLAB SAW — INSPECTION - BLADE PLACEMENT

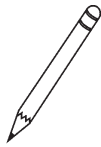
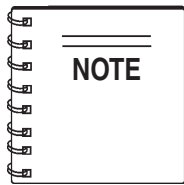

The following steps should be accomplished before placing the diamond blade on the **blade shaft**.

- Set the engine **ON/OFF** switch to the **OFF** position.
  - Raise the saw to a high position by cranking the Raise/Lower handle in a counterclockwise direction.
  - Use the Blade Nut Wrench & Blade Shaft Locking Wrench stored on the front section of the console to install the diamond blade.
  - Reference Figure 12 (Diamond Blade Placement) when removing or installing the diamond blade.
1. **Blade Guard** – Raise the front half of the blade guard to expose the blade shaft nut & outer flange.
  2. **Blade Nut Wrench** – Remove the blade nut wrench (3) from the tool holder and unscrew the blade shaft nut (right-side). This nut **loosens clockwise** and **tightens counterclockwise**.



3. **Blade Nut** – Remove the blade nut (4). For reassembly, **DO NOT** over tighten the blade nut against the outer flange. Tighten blade nut approximately 45-50 ft-lbs/62-69 N/m.
4. **Outside Blade Flange (Collar)** – Ensure that the flange face is clean and free of debris and is placed flush against the diamond blade (7). Check that the drive pin goes through the blade pin hole (6) and seats properly into the inner flange (8).
5. **Blade Pin Hole** – Align this hole with the drive pin hole on the inner flange collar.
6. **Diamond Blade** – Ensure that the proper blade has been selected for the job. Pay close attention to the directional arrow on the blade, **clockwise for right-side** cutting, **counter-clockwise for left-side** cutting. The arbor hole of the blade must match the 1" arbor of the blade shaft.
7. **Inner Flange Collar** – This flange is fixed upon the blade shaft, and is manufactured with a drive pin hole. The inside surface of the flange must be free of debris and permit a tight closure on the surface of the blade.

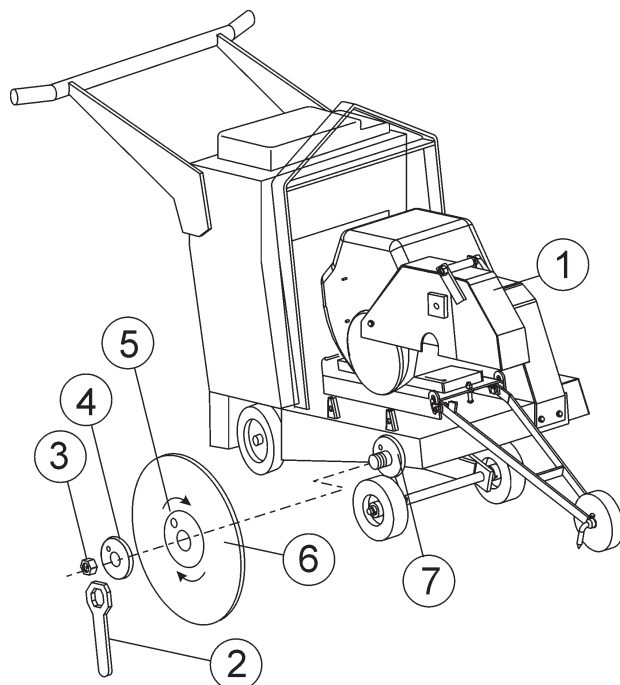

Figure 12. Diamond Blade Placement

# MQ SP2 SLAB SAW — INSPECTION -GUARDS, COVERS & BELTS

## Guards and Covers Check

### **WARNING**

**NEVER** operate the saw without blade guards and covers (Figures 13, 14 and 15) in place. **DO NOT** operate with the front of the blade guard raised. The blade exposure cannot exceed 180 degrees during operations. Adhere to the safety guidelines of the **American National standards Institute (ANSI) B7.1 and B7.5.**

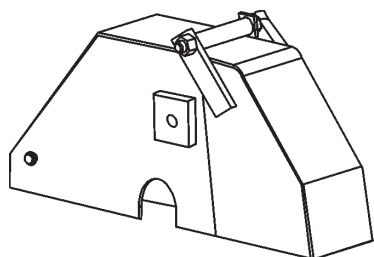

**Figure 13. Blade Guard**

**CHECK** the following on the **blade guard**:

- Check to ensure the capacity of the blade guard matches the diameter of your diamond blade.
- Check that the guard seats firmly upon the bayonet fitting of the saw frame.
- Check that the spring tensioned front cover of the guard is firmly seated with the rear section of the guard, and there are no gaps.
- Check the fit of the water hoses in the sides of the blade guard. **NEVER** lift the blade guard while cutting.
- Check that the flood water tubes are clear and open. Test the water supply for pressure and flow (to both sides of the blade) before sawing operations.

**CHECK** the following on the **blade flange cover**:

- Check that the flange cover seats firmly upon the bayonet fitting of the saw frame prior to operation.
- This flange cover is to be in place when cutting from either the right or left side of the saw.

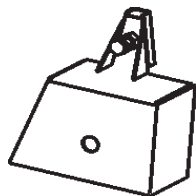

**Figure 14. Blade Flange Cover**

## V-Belts and Covers

### **CAUTION**

**NEVER** attempt to check the V-belt with the engine running because severe injury can occur. Keep fingers, hands, hair and clothing away from all moving parts.



## V-belts Alignment and Tensioning

This slab saw is equipped with 3 premium V-belts (3 for 13HP models, 4 V-belts for 20HP models) that have been aligned and tensioned by factory personnel. All V-belts **MUST** be installed for proper operation of the saw. Failure to run the saw with less than the required number of belts may damage the saw or equipment.

Use the following procedure to check the alignment of V-belts:

1. Remove the bolts that secure the V-belt cover (Figure 15) to the saw frame.
2. Check uniform parallelism (Figure 16) of V-belts and pulley (sheaves). Use a straight edge or machinists's square against both pulleys and adjust both pulleys until equally aligned.

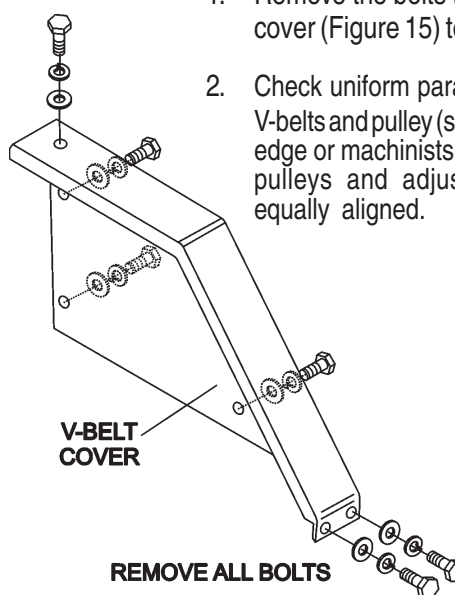

**Figure 15. V-Belt Cover**

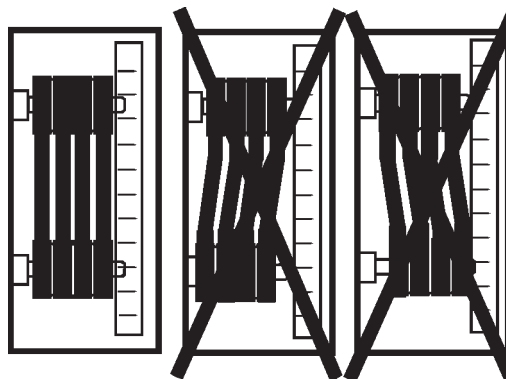

**Figure 16. V-Belt Parallelism**

# MQ SP2 SLAB SAW — INSPECTION - BELTS & WATER TANK

- Check V-belt tension (Figure 17) by using a tensionmeter (6.0 - 9.0 lbs.) against the inside belt at a mid point between the two pulleys, or by deflecting the center belt at a mid point 3/8" (10 mm) - 1/2" (13 mm).

CORRECT V-BELT TENSION 3/8 IN.  
(10 MM) TO 1/2 IN.(13 MM) WHEN DEPRESSED  
AT MIDPOINT AS SHOWN

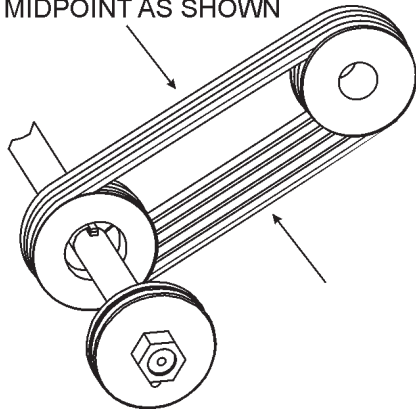

Figure 17. V-Belt Tension

- DO NOT** over or under tension the V-belts. Severe damage can occur to the saw and engine crank shaft if the belts are over tensioned. A decrease of power to the blade and poor performance will result if the belts are under tensioned (loose on pulleys).
- If the V-belts becomes worn or loose, replace them by using the following V-belt part numbers listed in Table 5.

## Water Tank

The SP2 Slab Saw is equipped with a removable 5-gallon on-board water tank fitted in the top of the console which can be connected to the brass hose fitting on the rear of the operators console (Figure 18).

Before using the water tank, ensure it is filled to capacity and connected to the hose fitting to provide lubrication during cutting. An external water source can also be connected to the SP2 for extended wet cutting operations.

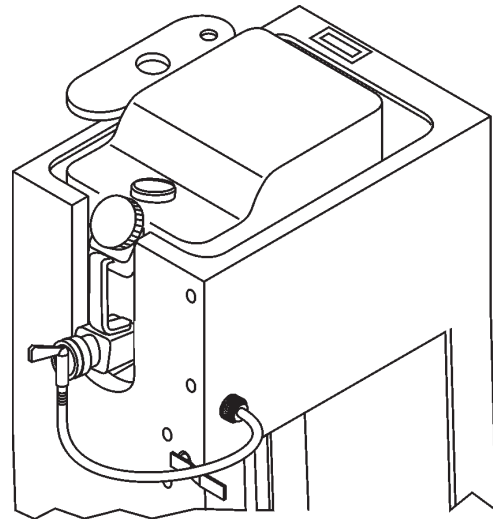

Figure 18. On-board Water Tank Hose Connection

Table 5. V-Belts and Pulleys

Engine Size	Saw Type	Blade Size	V-Belt P/N (Qty.)	Engine Pulley P/N	Blade Shaft Pulley P/N
13 HP Engine	Push	20 inch	16052 (3)	23665-001	25172-003
	Self-Propel			23703-003	25172-003
20 HP Engine	Self-Propel	20 Inch	15897 (4)	28833-002	23280-001

# MQ SP2 SLAB SAW — MANUAL START-UP (13HP HONDA ENGINE)

## CAUTION

**DO NOT** attempt to operate the saw until the Safety, General Information and Inspection sections have been read and understood. Depending on engine manufacturer, operating steps may vary. See engine operating manual.

The following start-up procedure makes reference to a **HONDA 13 HP Engine (Manual Start)**

## WARNING

When the engine is running the cutting blade is **ALWAYS spinning**. Raise the blade high above the surface when maneuvering the saw. Damage to the blade and/or saw may occur if the blade strikes the pavement.



1. Ensure the diamond blade has been mounted correctly and that it is raised above the surface you are about to saw.
2. For wet cutting operations, ensure the water tank is filled to capacity (5 gallons). Connect the water tank hose to the water system brass fitting on the rear of the console (Figure 18) and test for adequate water flow to the diamond blade before operation.
3. Place the **fuel valve lever** (Figure 19) to the **ON** position.

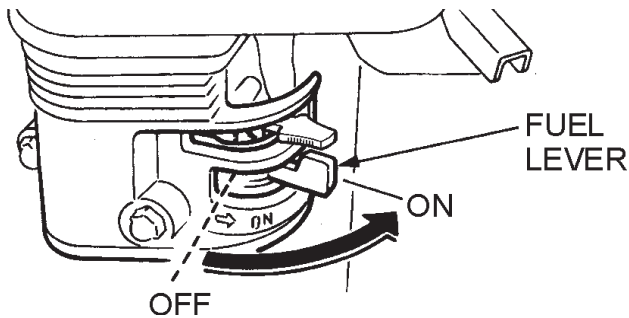

Figure 19. Fuel Valve Lever

4. Place the **Engine ON/OFF switch** (Figure 20) in the **ON** position.

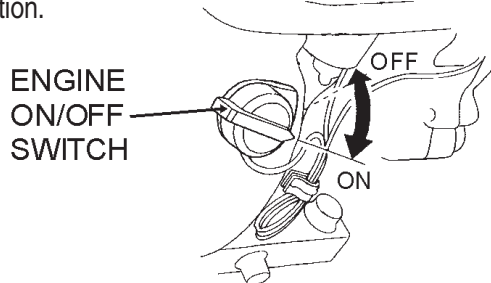
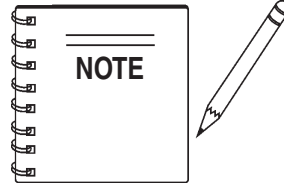

Figure 20. Engine ON/Off Switch



The **CLOSED** position of the choke lever enriches the fuel mixture for starting a **COLD** engine. The **OPEN** position provides the correct fuel mixture for normal operation after starting, and for restarting a warm engine.

5. If operating the SP2 in **cold weather conditions**, skip this step and proceed to step 6. Place the **Choke Lever** (Figure 21) in the **OPEN** position. Skip to step 7.

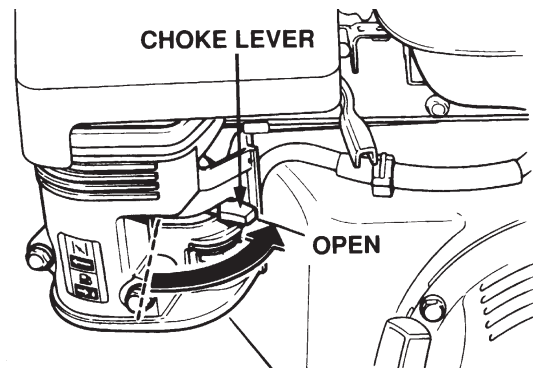

Figure 21. Choke Lever (Open Position)

6. If operating the SP2 in **cold weather conditions**, place the **Choke Lever** (Figure 22) in the **CLOSED** position.

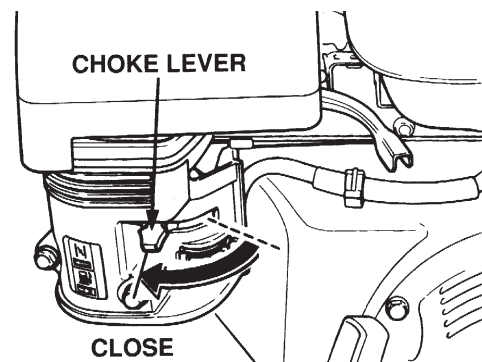

Figure 22. Choke Lever (Closed Position)

## CAUTION

The engine governor speed has been set at the factory. Changing the governor speed could damage the blade and/or the saw.



## MQ SP2 SLAB SAW — MANUAL START-UP (13HP HONDA ENGINE)

- Place the **throttle lever** (Figure 23) halfway between **FAST** and **SLOW** for starting. All sawing is done at full throttle. The engine governor speed is factory set to ensure optimum blade operating speeds.

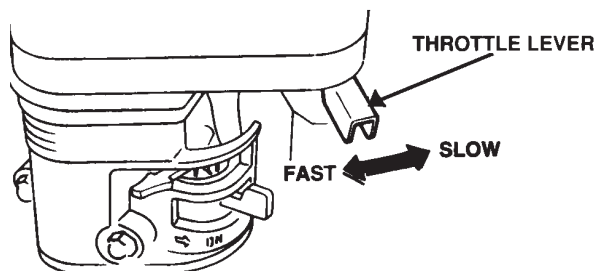

Figure 23. Throttle Lever

- Grasp the starter grip (Figure 24) and slowly pull it out. The resistance becomes the hardest at a certain position, corresponding to the compression point. Pull the starter grip briskly and smoothly for starting.

### CAUTION

- **DO NOT** pull the starter rope all the way to the end.
- **DO NOT** release the starter rope after pulling. Allow it to rewind as soon as possible.

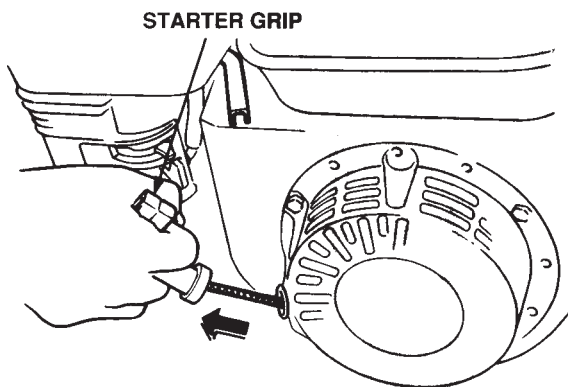

Figure 24. Starter Grip

- If the engine has started, slowly return the choke lever (Figure 22) to the **CLOSED** position. If the engine has not started repeat steps 1 through 8.
- Before the saw is placed into operation, run the engine for several minutes. Check for fuel leaks, and noises that would associate with a loose guard and/or covers.
- All sawing is done at full throttle. Your engine governor has been set at the factory to ensure an optimum speed setting.

# MQ SP2 SLAB SAW — ELECTRIC START-UP (20HP HONDA ENGINE)

## CAUTION

**DO NOT** attempt to operate the saw until the Safety, General Information and Inspection sections have been read and understood. Depending on engine manufacturer, operating steps may vary. See engine operating manual.

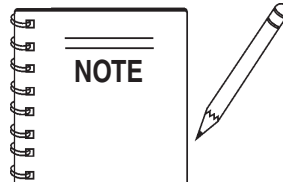

The **CLOSED** position of the choke lever enriches the fuel mixture for starting a **COLD** engine. The **OPEN** position provides the correct fuel mixture for normal operation after starting, and for restarting a warm engine.

The following start-up procedure makes reference to a **HONDA 20 HP Engine (Electric Start)**

1. Ensure the diamond blade has been mounted correctly and that it is raised above the surface you are about to saw.
2. For wet cutting operations, ensure the water tank is filled to capacity (5 gallons). Connect the water tank hose to the water system brass fitting on the rear of the console (Figure 18) and test for adequate water flow to the diamond blade before operation.
3. If operating the SP2 slab saw in **cold weather conditions**, skip this step and proceed to step 4. Place the **Choke Lever** (Figure 25) in the **OPEN** position. Skip to step 5.

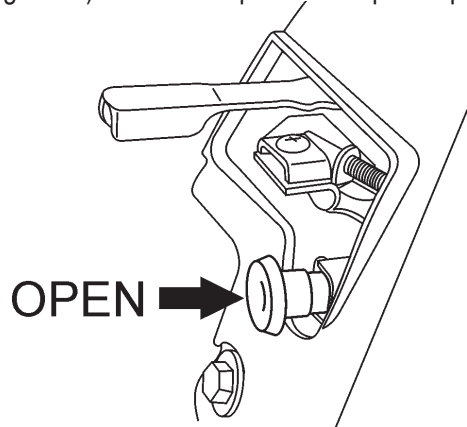

Figure 25. Choke Lever (Open Position)

4. If operating the SP2 in **cold weather conditions**, place the **Choke Lever** (Figure 22) in the **CLOSED** position.

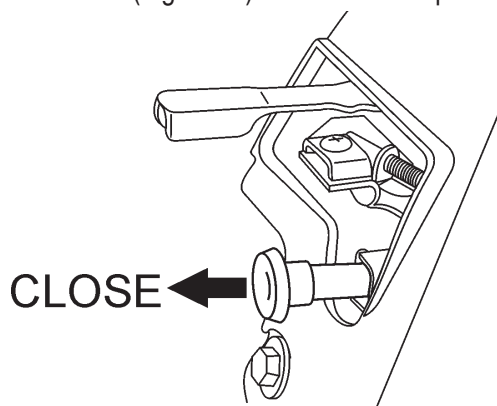

Figure 26. Choke Lever (Closed Position)

## CAUTION

The engine governor speed has been set at the factory. Changing the governor speed could damage the blade and/or the saw.

5. Place the **throttle lever** (Figure 27) halfway between **FAST** and **SLOW** for starting.

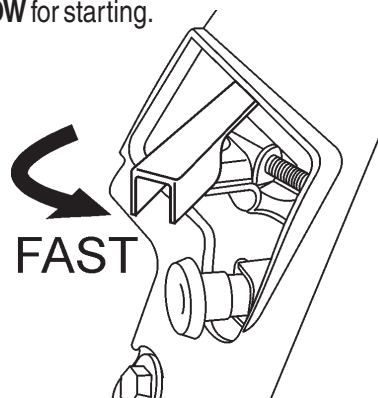

Figure 27. Throttle Lever (Fast Position)

6. Place the **Engine ON/OFF switch** (Figure 28) in the **ON** position.

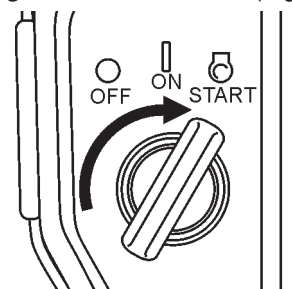

Figure 28. Ignition Switch (Start Position)

7. If the engine has started, slowly return the choke lever (Figure 26) to the **CLOSED** position. If the engine has not started repeat steps 1 through 6.
8. Before the saw is placed into operation, place the **throttle lever** in the **FAST** position and run the engine for several minutes. Check for fuel leaks, and noises that would associate with a loose guard and/or covers.
9. All cutting is done at **FULL THROTTLE**. Your engine governor has been set at the factory to ensure an optimum speed setting.

# MQ SP2 SLAB SAW — SHUT-DOWN PROCEDURES

## Stopping the Engine (13 HP Honda Engine)

### **! WARNING**

**NEVER** stop the engine while the blade is in the cut, except for extreme emergencies. A sudden stoppage of the engine at high speed while in a cut could damage the blade and/or saw, and may cause injury to the user or other in the operating area.

1. Place the **forward/reverse speed lever** in the **NEUTRAL** position (Self propelled models only).

**Figure 29. Speed Lever (Neutral Position)**

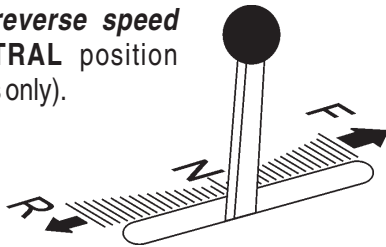

2. Place the **engine throttle lever** (Figure 30) in the **SLOW** position, and listen for the engine speed to decrease.

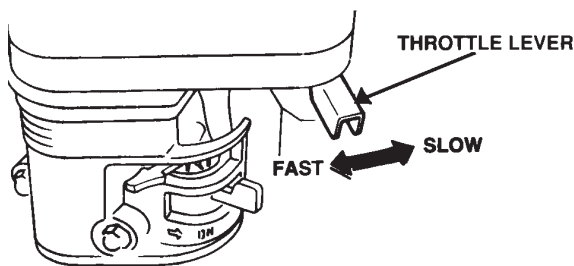

**Figure 30. Throttle Lever**

2. Turn the console **engine ON/OFF switch** (Figure 31) to the **OFF** position.

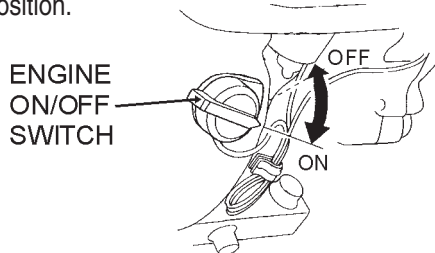

**Figure 31. Engine ON/Off Switch (Off Position)**

3. Place the fuel valve lever (Figure 32) to the **OFF** position.

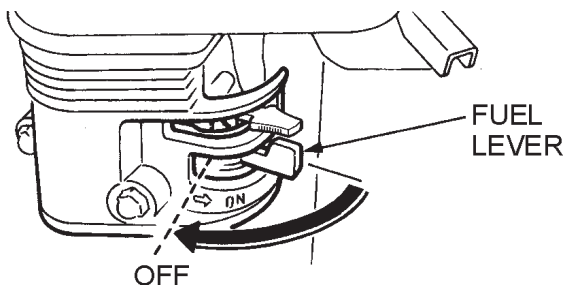

**Figure 32. Fuel Valve Lever (Off Position)**

## Stopping the Engine (20 HP Honda Engine)

1. Place the **forward/reverse speed lever** in the **NEUTRAL** position (Self propelled models only).
2. Place the **engine throttle lever** (Figure 33) in the **SLOW** position, and listen for the engine speed to decrease.

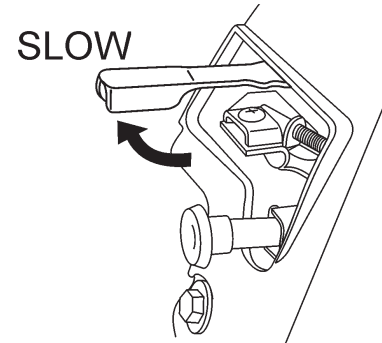

**Figure 33. Throttle Lever (Slow Position)**

3. Turn the **engine ON/OFF switch** (Figure 34) to the **OFF** position.

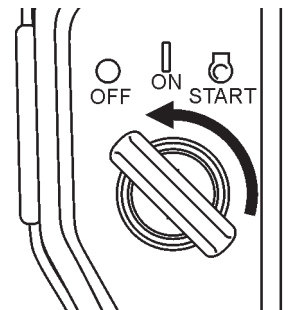

**Figure 34. Ignition Switch (OFF Position)**

## Emergency Stop Procedure

1. Turn the console **engine ON/OFF switch** (Figure 34) to the **OFF** position.

# MQ SP2 SLAB SAW — OPERATION

## CAUTION

**NEVER** stop the engine while cutting at high speeds, except for extreme emergencies. This can damage your SP2 Saw.

### Adjusting the Handle Bars

The SP2 has adjustable height handle bars. Before operating the saw, adjust the handle bar height to a comfortable working position:

1. Loosen the height adjustment bolts (Figure 35) on the handle bars until the handle bars can freely pivot.

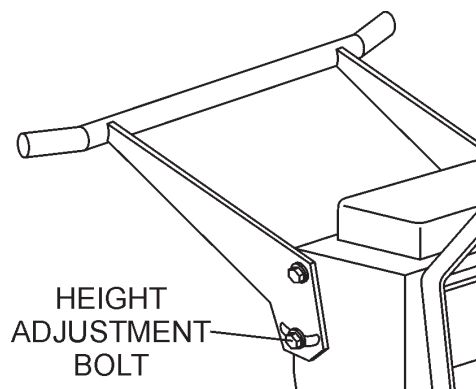

Figure 35. Handle Bar Adjustment Bolts

2. Move the handle bars (Figure 36) up or down to operators desired preference.

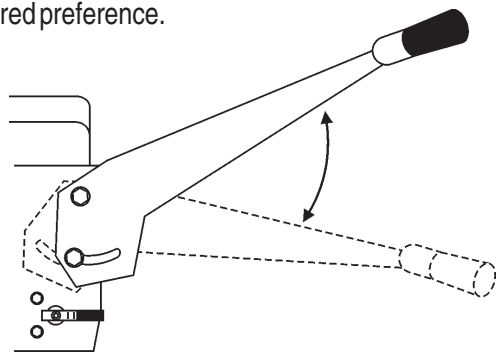

Figure 36. Handle Bar Height Adjustment

3. Tighten the height adjustment bolts to secure the handle bars in place.

## CAUTION

To avoid losing control of the SP2 slab saw, be sure to fully tighten the adjustment bolts before operating the saw to prevent the bolts from loosening during cutting.

### Adjusting the Blade Height

The SP2 saw uses a manual **raise/lower crank handle** located on the console with **clockwise** rotation providing lowering action, and **counter-clockwise** rotation providing raising and lowering action (Figure 37).

To adjust the blade height:

1. Pull upward on the raise/lower crank handle knob.
2. Rotate the crank handle **clockwise** to **lower the blade**. Rotate the crank handle **counter-clockwise** to **raise the blade** (Figure 37). The handle will stop rotating when the blade has been fully raised or lowered.

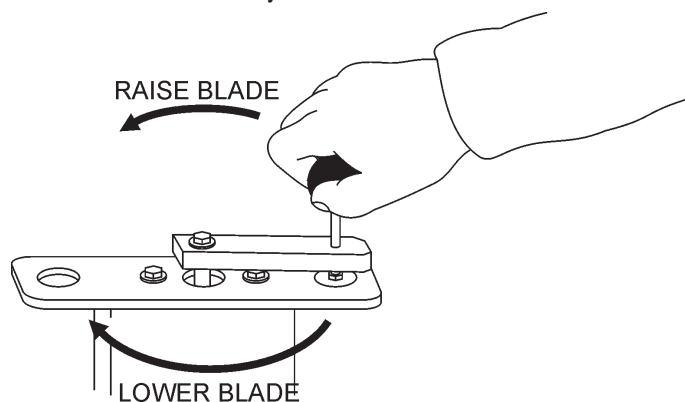
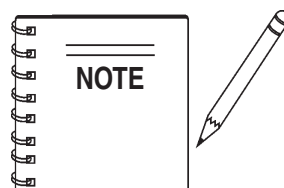

Figure 37. Blade Height Adjustment



When moving the saw around between cutting, fully raise the blade to avoid striking the ground with the blade.

### Determining the Cut Depth

When preparing to cut, your blade size determines the depth of the cut. See Table 6 to determine the proper blade size for your required cutting depth.

TABLE 6. BLADE SELECTION

Diamond Blade Diameter (In.)	Depth of Cut
12"	3-5/8"
14"	4-5/8"
16"	5-5/8"
18"	6-5/8"
20"	7-5/8"

## Traveling During Cutting (Push)

Push models of the SP2 saw must be manually moved by the operator during cutting operations. Ensure that the handlebars are secured in place on the console and push against them with a controlled amount of force to prevent losing control of the machine.

### CAUTION

**DO NOT** force the blade into the cut any faster than its designed tendency is effective cut and remove material. This can damage your blade and/or your machine.

## Traveling During Cutting (Self-Propelled)

Self-propelled models of the SP2 saw have a hydrostatic transmission which mechanically propels the saw during cutting operations. To prepare the machine for self-propelled cutting:

1. Place the **travel lever** in the **NEUTRAL** position.

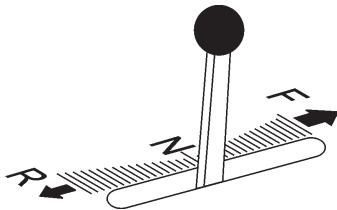

**Figure 38. Transmission Engage/Disengage Lever (Neutral Position)**

2. Lift the **transmission engage/disengage lever**, located on the console (Figure 39). Leaving the lever down disengages the transmission to allow for manual pushing during cutting or moving the machine around the job site.

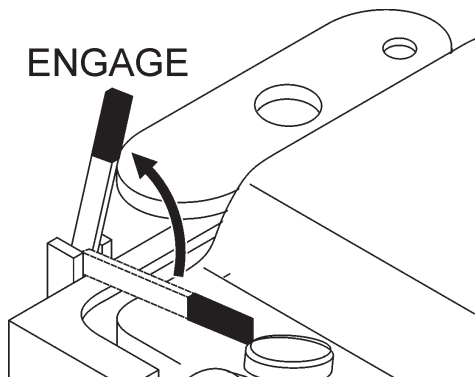

**Figure 39. Transmission Engage/Disengage Lever (Engage Position)**

3. Move the **travel lever** towards the **FORWARD** position to increase forward travel speed during cutting (Figure 40). Placing the travel lever fully forward will move the saw at maximum speed.

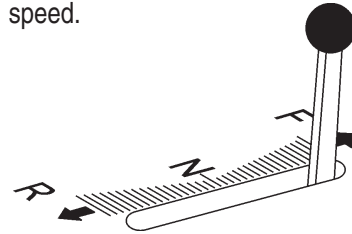

**Figure 40. Transmission Engage/Disengage Lever (Forward Position)**

4. When reverse movement is required, move the **travel lever** towards the **REVERSE** position (Figure 41). Placing the travel lever fully in reverse will move the saw backwards at its maximum reverse speed.

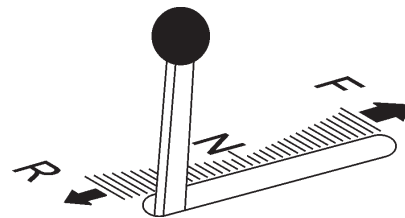

**Figure 41. Transmission Engage/Disengage Lever (Reverse Position)**

## Saw Alignment

1. The SP2 saw employs a front pointer (Figure 42) that has been precisely aligned with the diamond blade at the factory. Referencing the figure below, accurate tracking is accomplished by referencing the front pointer tip over the cut line. Precise saw direction is accomplished by slight operator pressure against the handle bars.

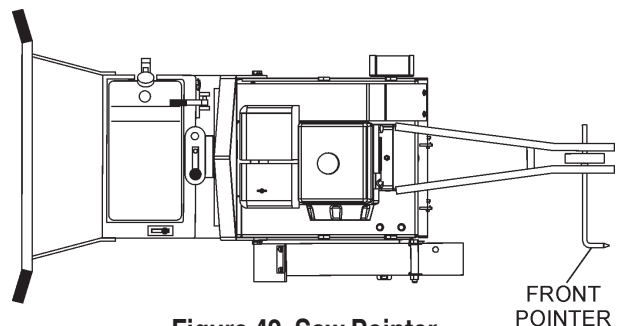

**Figure 42. Saw Pointer**

2. To reorient a pointer position, loosen the screw that secures the pointer bar to the shaft, adjust as necessary, and retighten the screw.

## Cutting

### **! WARNING**

The operator **MUST** wear the appropriate protective equipment and clothing while engaged in sawing. Failure to do so can result in **SERIOUS INJURY**.



### **! DANGER**

**DO NOT** operate this machine without the Blade Guard or V-belt Guards in place. While the blade is spinning, **DO NOT** place hands, feet, or other body parts near the blade to avoid **SERIOUS INJURY** or **DEATH**.



When cutting, determine the required cutting depth and use an appropriately sized blade. Deep sawing is wasteful to the life of the blade.

The preferred method of sawing is to **Step Cut** in increments of 2" (51 mm). Step Cutting provides the optimum opportunity for the blade to cut fast and last longest.

### Wet Cutting Operation

1. Connect hose from water source (on-board water tank or external water source) to the hose fitting connection (Figure 3) of the saw. The source pressure should be approximately 30-40 psi.
2. Ensure the vinyl water tubes are properly inserted into the blade guard holes and are clear of any obstructions.
3. Turn water source on (Figure 43).

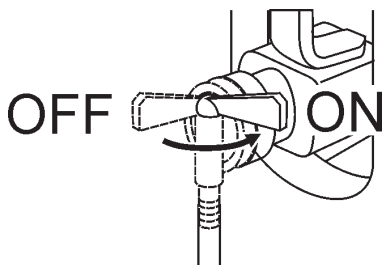

Figure 43. On-board Water Tank ON/OFF Valve

4. Open the **water system valve** on the left side of the console by moving the lever to the **ON** position (Figure 44) and ensure the water is flowing equally to both sides of the diamond blade.

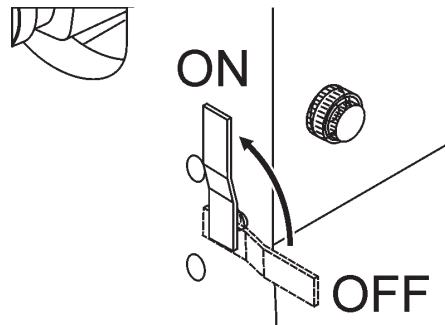

Figure 44. Water System ON/OFF Valve

5. Align the saw along the cut line utilizing the front pointer.

### **! CAUTION**

**ALWAYS** saw in a straight line only. **SERIOUS DAMAGE** to the blade or saw may occur if the saw is twisted or forced to cut radius shapes.

6. Slowly lower the diamond blade onto the cut line by cranking the **Raise/Lower handle** **CLOCKWISE** (Figure 37). When the handle can no longer be turned, the blade will be at its full rated depth.

### **! WARNING**

If the water supply to your blade is interrupted, **STOP** cutting **immediately** to prevent damage to your blade and/or saw.

If the engine stalls for **ANY** reason during cutting, raise the blade out of the cut before restarting.

7. For self-propelled models, follow steps 1-4 of the **Traveling During Cutting (Self-Propelled)** section.  
For push models, use the **Traveling During Cutting (Push)** instructions.
8. The rotation of the blade creates a tendency for the saw to slightly pull in a particular direction. To ensure a straight line of sawing, apply pressure against the appropriate side of the handle bar as you slowly advance the saw forward.

### **! CAUTION**

**DO NOT** force the blade into the cut any faster than its design will allow. This can damage your blade and/or your machine.

### Dry Cutting Operation

When dry cutting, follow steps 5-8 of the **Wet Cutting Operation** section.

## Finishing A Cut

1. Raise the blade out of the cut by cranking the **Raise/Lower handle COUNTER-CLOCKWISE** (Figure 37). Raise the blade high enough out of the cut to clear the surface and allow the saw to be maneuvered.
2. Move the engine throttle lever to the idle (**SLOW**) position (Figure 30, 33).
3. Set the engine **ON/OFF** switch to the **OFF** position (Figure 31, 34).
4. Place the water valve (Figure 44) in the **OFF** position (as required).

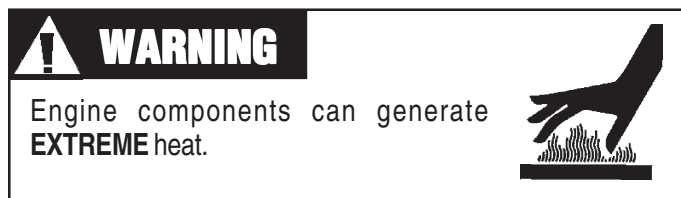

## Diamond Blades

Diamond blade sawing consists of cutting **WET** (using water to cool the blade) or **DRY** (using the circulating air to cool the blade).

Selecting the diamond blade **TYPE** and **GRADE** defines how the blade will perform both in cutting speed and blade life.

Selection of the proper diamond blade consists of:

- Determining **WET** or **DRY** cutting
- Material to be Cut
- Type of Saw Being Used
- Horsepower of Saw
- Hardness Characteristics of the Material
- Performance Expectations

Factors for sawing economy:

- Type of Blade
- Depth of Cut
- Sawing Speed
- Characteristics of the Material Being Cut
- Wet or Dry Sawing

## Blade Speed

A diamond blade's performance is directly connected to specific peripheral (rim) speeds.

The following shaft rotational speeds have been factory set to ensure optimum blade performance.

- SP2 20" Capacity - 2,800 RPM.

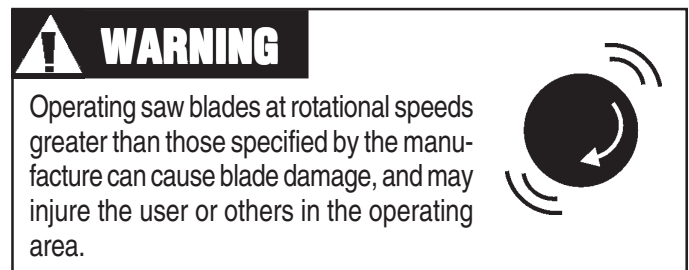

# MQ SP2 SLAB SAW — MAINTENANCE

## Maintenance

### **WARNING**

General maintenance practices are crucial to the performance and longevity of your saw. The extreme environments of sawing operations require routine cleaning, lubrication, belt tensioning, and inspection for wear and damage

The following procedures devoted to maintenance can prevent serious saw damage or malfunctioning. Before servicing or inspection, **ALWAYS** park the saw on a level surface with the blade removed, and the Console Engine **ON/OFF** switch & Engine **ON/OFF** switch in “**OFF**” position.

Some maintenance operations may require the engine to be run. Ensure that the maintenance area is well ventilated. Exhaust contains poisonous carbon monoxide gas that can cause of unconsciousness and may result in **DEATH**.



## General Cleanliness

**Clean the machine daily.** Remove all dust and slurry build up. If the saw is steam cleaned, ensure that lubrication is accomplished **AFTER** steam cleaning operations.

## General Engine Care

### Engine check:

Check daily for any oil and/or fuel leakage, thread nut & bolt tightness, and overall cleanliness.

### Engine oil:

Check daily. Inspect with blade removed and saw frame level on a level surface. Keep the oil clean, and at the proper servicing level (Figure 8). **DO NOT OVERFILL!** SAE 10W-30 of SG is recommended for general use.

### Engine oil change:

Change engine oil the first month or 20 hours of operation. Then every 3 months/or 50 HOURS of operation. See Engine Owner's Manual for detailed information.

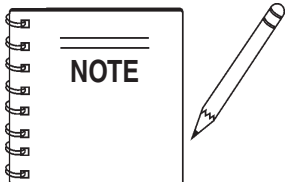

**ALWAYS** dispose of used oil in a responsible manner. Ensure that the disposition of all hazardous waste is handled properly. Call your Recycling Center for information about recycling engine oil.

### Engine air filter:

Clean air filter 2 to 3 times daily when **DRY** cutting. See Engine Owner's Manual for detailed information.

### Engine tank & strainer:

Clean every year/or 300 hours.

### Fuel line:

Replace every two years/or as necessary.

### Spark plug:

Clean/adjust every 6 months/or 100 hours. Replace every year/ or 300 hours.

## Bearing Lubrication Care

There are four grease points for the SP2 saw. [Use only Premium Lithium 12 based Grease, conforming to NLG1 Grade #2 consistency.]

### Rear Wheels (1):

Grease daily, see Undercarriage Assy., item 10

### Blade Shaft Bearings (2):

Grease daily, see Blade Shaft Assy., item 15

### Raise/Lower Adjust Tube (1):

Grease daily, see Raise/Lower Assy., item 2

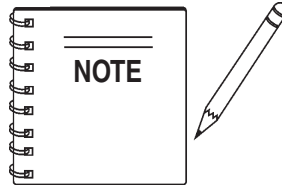

When cutting **DRY**, lubricate blade shaft bearings 2 to 3 times daily. The grease can provide an added protective seal for the bearings.



## General Transmission Care (Self-Propelled Models only)

All SP2 model saws utilize spline gear wheel design coupled with an EATON Model 7 Hydrostatic Transmission that provides forward/reverse propulsion. The simple design of the system keeps maintenance to a minimum.

### Transmission Reservoir Cup:

Check every 8 hours of operation. When the transmission is **cold** (A), check oil level against the level indicator (see Figure 45).

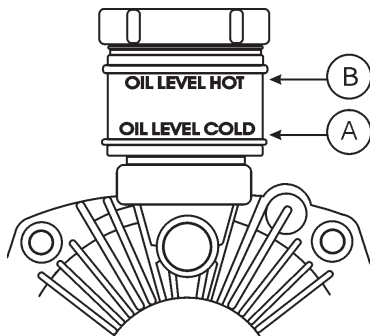

Figure 45. Transmission Reservoir

### Servicing:

The transmission reservoir is factory filled. Should servicing be required, use SAE20W-20, API classification (SE,CC,CD) or better, General Motors Dexron B, Ford M2C-33F, M2C-41A or International Harvester Hy-Tran fluids. For extreme **hot weather**, drain oil and refill with an oil having a viscosity of SAE30W-30 or SAE40W-40.

### Drive Chain:

Check every 50 hours. Periodically wipe the chain clean and re-lubricate with penetrating chain oil.

The drive chain may stretch requiring tension adjustments. To adjust the drive chain tension:

1. Loosen the (3) transmission attachment screws (Hydrostatic Transmission Assy., item 2)
2. Pivot the transmission in the “U” slots of the **transmission mount** until the proper tension is achieved (Hydrostatic Transmission Assy., item 7).

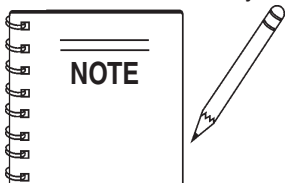

Excessive tension on the drive chain will reduce chain life.

### Spline Gear Wheels:

Check every 25 hours and clean as necessary. If the spline wheels **DO NOT** engage the **rear wheels** with sufficient pressure, slippage of the rear wheels may occur.

To adjust the **Spline Gear Assembly**:

1. Place the **transmission engage/disengage lever** in the **DISENGAGE** position (Figure 46).

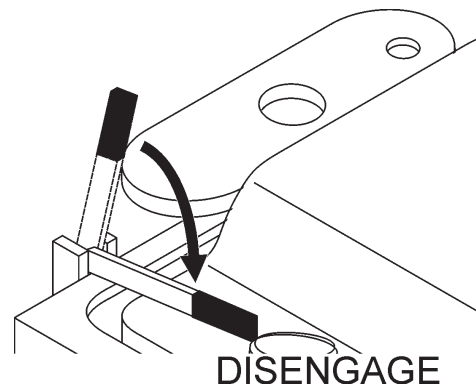

Figure 46. Transmission Engage/Disengage Lever (Disengage Position)

3. Loosen the linkage adjustment nut and **slightly** lengthen the linkage rod (see Transmission Engage Lever Assy., items 11 and 13).
4. Move the **transmission engage/disengage lever** to the **ENGAGE** position to observe the proper spline-to-rear wheel contact.
5. Retighten the adjustment nut.

## Drive V-Belt Check

The V-Belts of the SP2 slab saw have been factory set utilizing precision standards. Operating the saw with less than the specified number of V-belts (See Table 5), or belts that are **slipping** or are **over-tensioned** will significantly diminish the performance of the saw, and may cause damage to the blade.

## Drive V-Belt(s) Replacement & Tension Adjustments

Reference Pointers and Covers Assembly, Blade Shaft Assembly, and Engine Mount Assembly for this operation.

1. Remove the **Belt Guard** (Pointers and Covers Assy., item 15), then loosen the tension of the V-Belts
2. Loosen the (4) 1-1/2" HHC screws (Engine Mount Assy., item 5).
3. Loosen and back-off the **Engine Mount Carriage Bolt** (Engine Mount Assy., item 1) from the frame to permit the **Engine Base Plate** (Engine Mount Assy., item 9) to pivot.
4. Pivot the Engine Base Plate to provide slack in the Drive V-belts.
5. Remove/Replace the required V-belts (See Table 5).
6. Rotate the engine back into place and tighten the Engine Mount Carriage Bolt.
7. Adjust for the correct V-belt tension (See Figure 47).

CORRECT V-BELT TENSION 3/8 IN.  
(10 MM) TO 1/2 IN. (13 MM) WHEN DEPRESSED  
AT MIDPOINT AS SHOWN

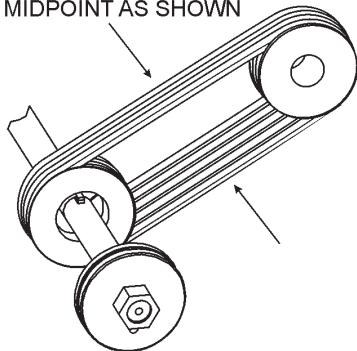

Figure 47. V-Belt Adjustment/Tension

8. Retighten the (4) 1-1/2" HHC screws.
9. Replace all guards and covers.

**! WARNING**

**NEVER** attempt to check the V-belt with the engine running. Severe injury can occur if your hand gets caught between the V-belt and the clutch. Always use safety gloves.

## Adjust V-Belt Alignment/Replacement Pulleys

The V-belts and their respective pulleys have been professionally aligned at the factory. If there is a requirement to remove/replace or adjust the pulleys, proceed with the following instructions.

1. Select the proper sized pulley both in outside diameter and arbor size. **Use approved parts to ensure the component compatibility.**
2. A change in Pulley diameters may require specifically sized V-Belts. **Contact Multiquip Service Department to ensure V-Belt compatibility.**
3. Complete Drive V-Belt(s) Replacement steps (1 through 4)
3. Remove the V-Belts from around the Pulley(s).
4. Remove the set screws that secure the pulleys to the respective shafts (PTO shaft) for engine pulley or the (blade shaft) for the blade shaft pulley.
5. Remove/replace the pulley by sliding it off the shaft.
6. Reorient the new pulley on the shaft, and ensure precise pulley alignment by utilizing an accurate straight edge (see Figures 48 and 49).
7. Replace/tighten set screws treated with a drop of **LOCTITE Threadlocker 266.**
8. Orient the proper replacement V-Belt(s) around the blade shaft pulley and engine pulley.
9. Reference steps 6-9 of the **Drive V-Belt(s) Replacement** steps.

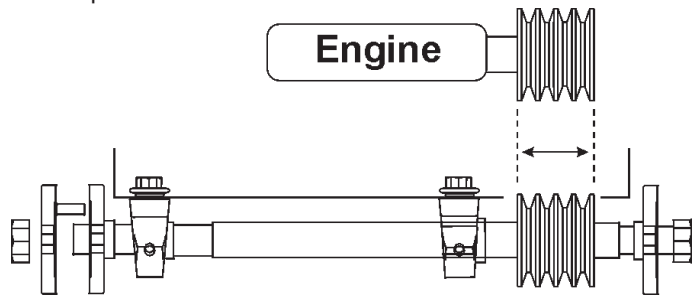

Figure 48. Pulley Alignment

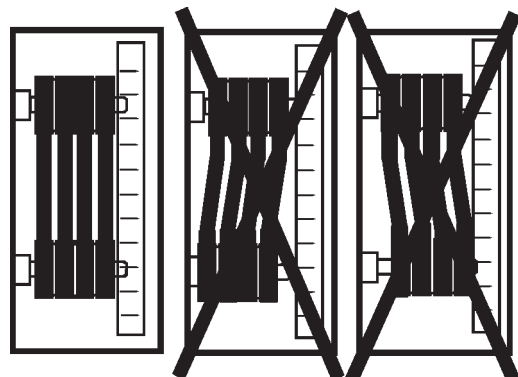

Figure 49. V-Belt Alignment

## Blade Shaft Bearing Replacement

The SP2 slab saw is supported by "tapped base lock collar (w/ set screw)" self-aligning **Blade Shaft Bearings** (Figures 51 and 52). These heavy duty bearings support the 1-1/4 blade shaft, and have grease (zerk) points conveniently located for service.

1. It is recommended to replace both left & right bearings at the same time.
2. Follow steps 1 thru 4 of Drive V-Belt(s) Replacement & Tension Adjustments.
3. Remove Drive V-belts.

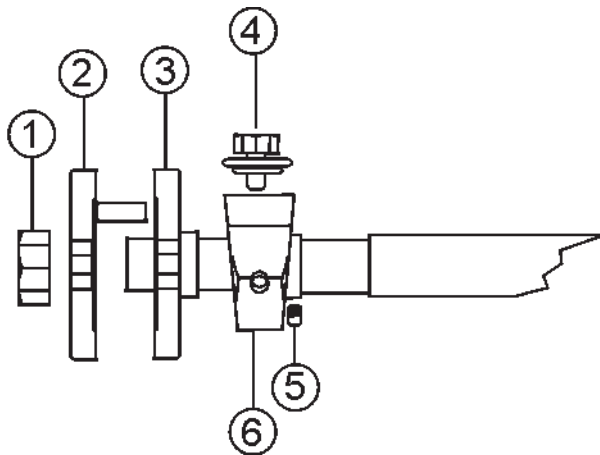

Figure 50. Blade Side Bearing (Right Side)

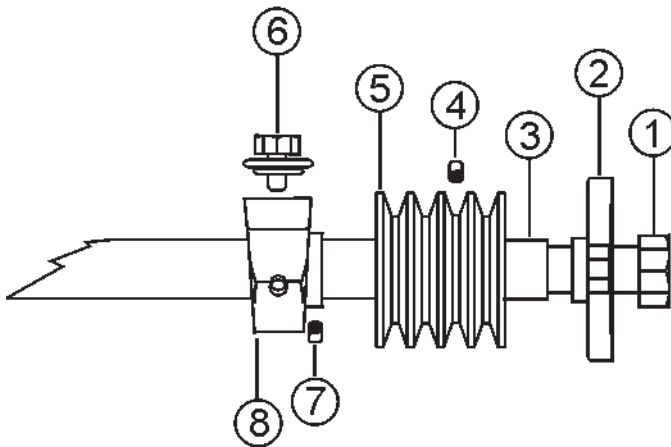

Figure 51. Pulley Side Bearing (Left Side)

Reference Figure 50 & Figure 51 for steps 4-9

4. Remove **Blade Hex Nuts** (Figures 50 & 51, item 1) and **Outside/Inside Blade Flanges** (Figures 50, item 2 & 3)
5. Loosen **set screws** (Figure 51, item 4) and slide **Pulley** (Figure 51, item 5) off the Blade Shaft. Loosen Bearing set screw, remove **Bearing Bolt** (Figure 51, item 6) and slide the **Blade Shaft Bearing** (Figure 51, item 8) off the blade shaft.
6. Loosen **set screws** (Figure 50, item 5), remove **Bearing Bolt** (Figure 50, item 4) and slide the **Blade Shaft Bearing** (Figure 50, item 6) off the blade shaft.
7. Replace **Blade Shaft Bearings** and reassemble the Blade Shaft Assembly.
8. Re-tension Drive V-belts as shown in the Drive V-Belt(s) Replacement & Tension Adjustments section.
10. Replace all guards and covers.

# MQ SP2 SLAB SAW — MAINTENANCE

## Battery Maintenance

Mishandling of the battery shortens the service life of the battery and adds to maintenance cost. When handling the battery do the following:

- Be careful not to let the battery electrolyte come in contact with your body or clothing.
- Always wear **eye protection** and **rubber gloves**, since the battery contains sulfuric acid which burns skin and eats through clothing.
- Always check the battery terminals periodically to ensure that they are in good condition.
- Use wire brush or sand paper to clean the battery terminals.
- Always check battery for cracks or any other damage. If white pattern appears inside the battery or paste has accumulated at the bottom, replace the battery.
- If the pump will not be in operation for a long period of time, store in cool dry place and check the battery charge level every month to maintain the performance of the battery.

- Check the battery regularly and make sure that each electrolyte level is to the bottom of the vent well (Figure 43). If necessary add only distilled water in a well-ventilated area.

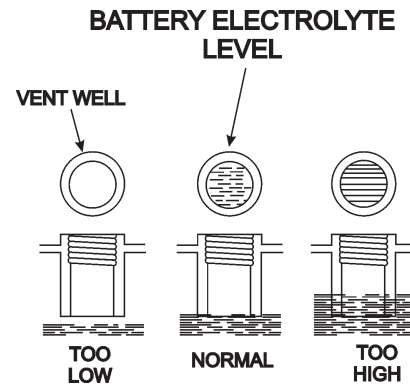

Figure 43. Battery Electrolyte Levels

**! WARNING**

Wear **safety glasses** or **face mask**, **protective clothes**, and **rubber gloves** when working with battery.

The safety icons include a pair of safety glasses, a face mask, two pairs of rubber gloves, and a full-body illustration of a worker wearing a hard hat, safety glasses, protective clothing, and rubber boots.

# MQ SP2 SLAB SAW — 13HP ENGINE WIRING DIAGRAM (RECOIL START)

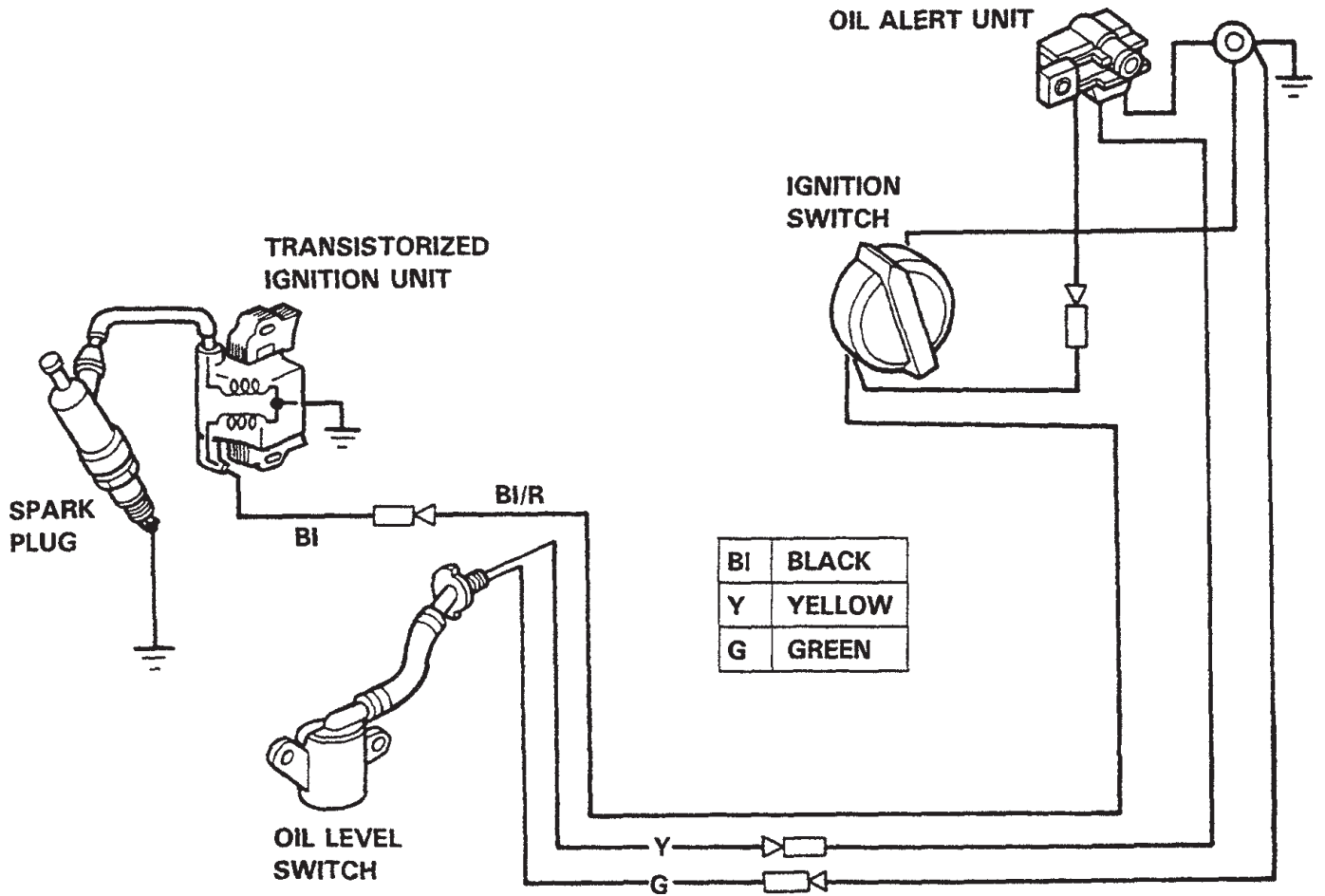
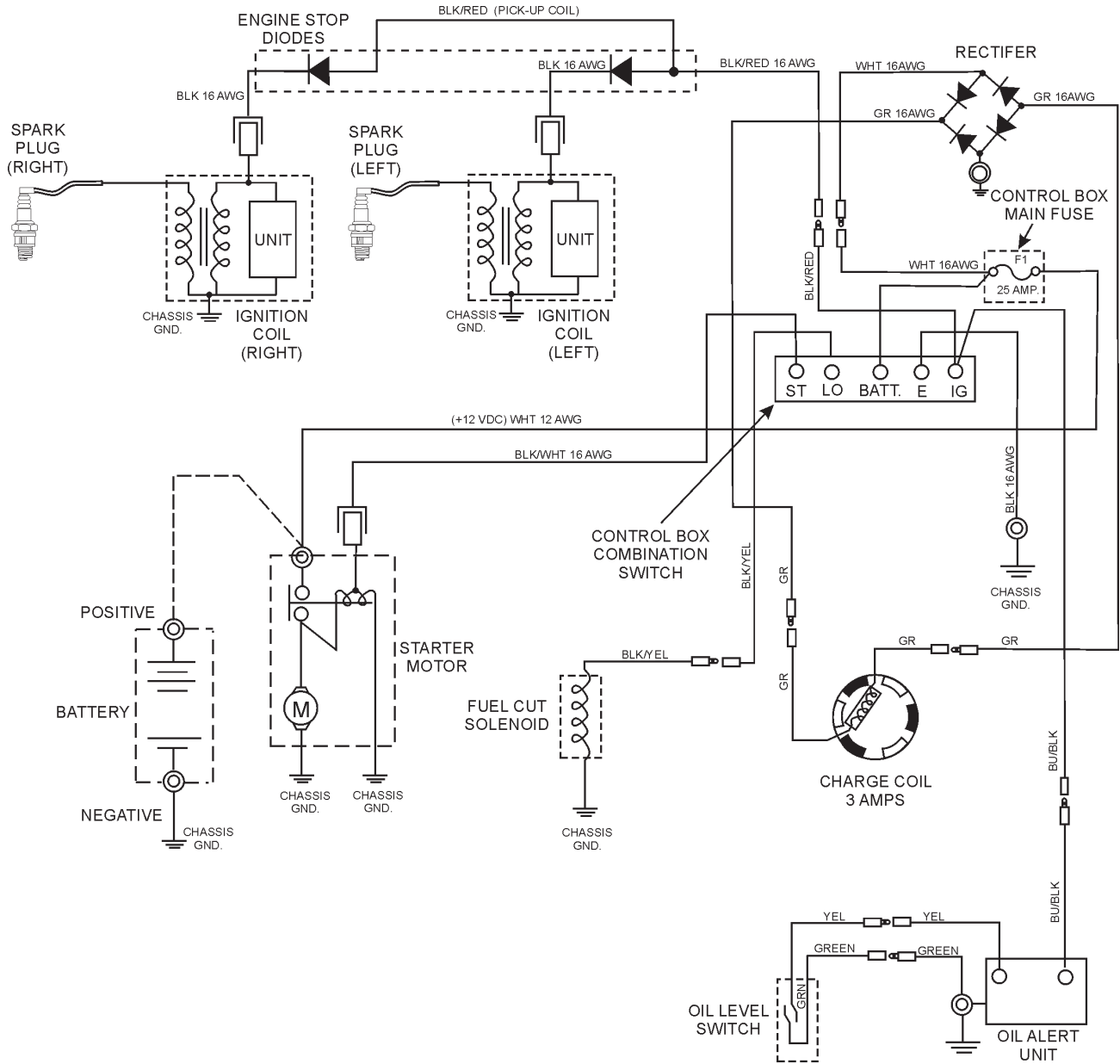

Figure 52. 13HP Honda Engine Wiring Diagram

# MQ SP2 SLAB SAW — 20HP ENG. WIRING DIAGRAM (ELECTRIC START)



COMBINATION SWITCH CONTINUITY

COLOR CODE	
BLK	BLACK
WHT	WHITE
RED	RED
YEL	YELLOW
GRN	GREEN
GRAY	GRAY
BU	BLUE

	IG	E	BAT	LO	ST
OFF	○—○				
ON			○—○		
ST			○—○	○—○	○—○

Figure 52. 20HP Honda Engine Wiring Diagram

# MQ SP2 SLAB SAW — TROUBLESHOOTING (ENGINE)

Practically all breakdowns can be prevented by proper handling and maintenance inspections, but in the event of a breakdown, please take a remedial action following the diagnosis based on the Engine Troubleshooting (Table 7) information shown below and on the proceeding page. If the problem cannot be remedied, please leave the unit just as it is and consult our company's business office or service plant.

<b>TABLE 7. ENGINE TROUBLESHOOTING</b>		
<b>SYMPTON</b>	<b>POSSIBLE CAUSE</b>	<b>SOLUTION</b>
Difficult to start, "fuel is available, but no SPARK at spark plug".	Spark plug bridging?	Check gap, insulation or replace spark plug.
	Carbon deposit on spark plug?	Clean or replace spark plug.
	Short circuit due to deficient spark plug insulation?	Check spark plug insulation, replace if worn.
	Improper spark plug gap?	Set to proper gap.
Difficult to start, "fuel is available, and SPARK is present at the spark plug".	Console or engine ON/OFF switch is shorted?	Check switch wiring, replace switch.
	Ignition coil defective?	Replace ignition coil.
	Improper spark gap, points dirty?	Set correct spark gap and clean points.
	Condenser insulation worn or short circuiting?	Replace condenser.
	Spark plug wire broken or short circuiting?	Replace defective spark plug wiring.
Difficult to start, "fuel is available, spark is present and compression is normal"	Wrong fuel type?	Flush fuel system, and replace with correct type of fuel.
	Water or dust in fuel system?	Flush fuel system.
	Air cleaner dirty?	Clean or replace air cleaner.
Difficult to start, "fuel is available, spark is present and compression is low"	Suction/exhaust valve stuck or protruded?	Re-seat valves.
	Piston ring and/or cylinder worn?	Replace piston rings and or piston.
	Cylinder head and/or spark plug not tightened properly?	Torque cylinder head bolts and spark plug.
	Head gasket and/or spark plug gasket damaged?	Replace head and spark plug gaskets.
No fuel present at carburetor.	Fuel not available in fuel tank?	Fill with correct type of fuel.
	Fuel cock does not open properly?	Apply lubricant to loosen fuel cock lever, replace if necessary.
	Fuel filter clogged?	Replace fuel filter.
	Fuel tank cap breather hole clogged?	Clean or replace fuel tank cap.
	Air in fuel line?	Bleed fuel line.

# MQ SP2 SLAB SAW — TROUBLESHOOTING (ENGINE)

**TABLE 7. ENGINE TROUBLESHOOTING (CONTINUED)**

SYMPTON	POSSIBLE CAUSE	SOLUTION
"Weak in power" compression is proper and does not misfire.	Air cleaner not clean?	Clean or replace air cleaner
	Improper level in carburetor?	Check float adjustment, re-build carburetor.
	Defective Spark plug?	Clean or replace spark plug.
	Defective Spark plug?	
"Weak in power" compression is proper but misfires.	Water in fuel system?	Flush fuel system, and replace with correct type of fuel.
	Dirty spark plug?	Clean or replace spark plug.
	Ignition coil defective?	Replace ignition coil.
Engine overheats.	Spark plug heat value improper?	Replace with correct type of spark plug.
	Correct type of fuel?	Replace with correct type of fuel
	Cooling fins dirty?	Clean cooling fins.
Rotational speed fluctuates.	Governor adjusted correctly?	Adjust governor.
	Governor spring defective?	Replace governor spring.
	Fuel flow restricted?	Check entire fuel system for leaks or clogs.
Recoil starter malfunction.	Recoil mechanism clogged with dust and dirt?	Clean recoil assembly with soap and water.
	Spiral spring loose?	Replace spiral spring.



## MQ SP2 SLAB SAW — TROUBLESHOOTING (BLADE)

Practically all breakdowns can be prevented by proper handling and maintenance inspections, but in the event of a breakdown, please take a remedial action following the diagnosis based on the Blade Troubleshooting (Table 8) information shown below and on the proceeding page. If the problem cannot be remedied, please leave the unit just as it is and consult our company's business office or service plant.

<b>TABLE 8. BLADE TROUBLESHOOTING</b>		
<b>SYMPTON</b>	<b>POSSIBLE CAUSE</b>	<b>SOLUTION</b>
Blade slows or Stops cutting, still remains on blade.	Blade too hard for the material being cut.	Consult Dealer or Multiquip for correct blade. Try cutting very soft material (sandstone, silica brick, cinder block) to "Redress" the blade.
	Engine Torque diminished because of loose V-Belts.	Tighten and/or replace V-Belts.
	Insufficient Engine power.	Check Throttle setting. Check Engine horsepower.
	Improper direction of rotation.	Check that the blade is oriented, and rotational arrow points in a "Down-Cutting" direction.
	Blade is slipping on the blade shaft.	Check that the blade & flange pin is properly installed on the blade shaft (see Figure 10).
Blade does not cut straight and/or true.	Blade being used on misaligned saw.	Check blade shaft bearings and alignment integrity.
	Blade is excessively hard for the material being cut.	Check specifications of the blade with the material being cut. Consult Dealer or Multiquip for information.
	Blade being used at improper RPM.	Ensure blade surface feet per minute speed (SFPM) is approximately 6,000 (see Page 29).
	Blade improperly mounted on arbor shoulders and flanges.	Ensure blade is properly affixed on the blade shaft.
	Excessive force applied to blade while cutting.	Do not force the blade in the cut. Apply a slow/steady pace to sawing..
Blade discoloring, crackling and/or wearing excessively.	Blade too hard for the material being cut.	Consult Dealer or Multiquip for correct blade. Try cutting very soft material (sandstone, silica brick, cinder block) to "Redress" the blade.
	Blade improperly mounted on arbor shoulders and flanges.	Ensure blade is properly affixed on the blade shaft. Ensure the blade flanges are clean & free of debris.
	Blade not receiving enough cooling water or air.	Ensure proper flow & volume of water is provided for wet cutting blades. Ensure sufficient cooling air is circulated about a dry cutting blade.
	Arbor hole out of round	Ensure blade is properly affixed on the blade shaft.
	Incorrect blade chosen for material being cut.	Check specifications of the blade with the material being cut. Consult Dealer or multiquip for information.
	Excessive force applied to blade while cutting.	Do not force the blade in the cut. Apply a slow/steady pace to sawing.

# MQ SP2 SLAB SAW — EXPLANATION OF CODE IN REMARKS COLUMN

How to read the marks and remarks used in this parts book.

## Items Found In the “Remarks” Column

**Serial Numbers**-Where indicated, this indicates a serial number range (inclusive) where a particular part is used.

**Model Number**-Where indicated, this shows that the corresponding part is utilized only with this specific model number or model number variant.

## Items Found In the “Items Number” Column

All parts with same symbol in the number column, \*, #, +, %, or >, belong to the same assembly or kit.

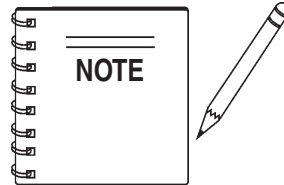

If more than one of the same reference number is listed, the last one listed indicates newest (or latest) part available.

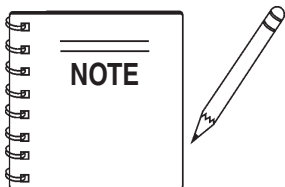

The contents of this parts catalog are subject to change without notice.

# MQ SP2 SLAB SAW — SUGGESTED SPARE PARTS

## SP2 SLAB SAW (13HP PUSH) 1 to 3 Units

Qty. ....	P/N .....	Description
3 .....	16052 .....	V-BELTS, DRIVE
1 .....	29013-001 .....	WRENCH, BOX END 1-1/2 IN.
1 .....	60087 .....	ROPE, FRONT POINTER 1/4 IN.
2 .....	15081 .....	GRIPS, HANDLE BAR 1 IN.
1 .....	06922-003 .....	BLADE SHAFT NUT, RIGHT SIDE
1 .....	07038-016 .....	BLADE SHAFT NUT, LEFT SIDE
1 .....	26928-002 .....	OUTER BLADE FLANGE
3 .....	17210ZE3505 .....	ELEMENT, AIR CLEANER
3 .....	9807956846 .....	SPARK PLUG
1 .....	17620ZH7023 .....	CAP, FUEL TANK
1 .....	28462ZV7003 .....	ROPE, RECOIL STARTER

## SP2 SLAB SAW (20HP SELF-PROPELLED) 1 to 3 Units

Qty. ....	P/N .....	Description
3 .....	15897 .....	V-BELTS, DRIVE
1 .....	07055-051 .....	V-BELTS, TRANSMISSION
1 .....	29013-001 .....	WRENCH, BOX END 1-1/2 IN.
1 .....	60087 .....	ROPE, FRONT POINTER 1/4 IN.
2 .....	15081 .....	GRIPS, HANDLE BAR 1 IN.
1 .....	06922-003 .....	BLADE SHAFT NUT, RIGHT
1 .....	07038-016 .....	BLADE SHAFT NUT, LEFT
1 .....	26928-002 .....	OUTER BLADE FLANGE
3 .....	17210759013 .....	ELEMENT, AIR CLEANER
3 .....	1540090H305PE .....	OIL FILTER
3 .....	9807956846 .....	SPARK PLUG
1 .....	15229 .....	CAP, FUEL TANK
1 .....	28462ZV7003 .....	ROPE, RECOIL STARTER

## SP2 SLAB SAW (13HP SELF-PROPELLED) 1 to 3 Units

Qty. ....	P/N .....	Description
3 .....	16052 .....	V-BELTS, DRIVE
1 .....	07055-051 .....	V-BELTS, TRANSMISSION
1 .....	29013-001 .....	WRENCH, BOX END 1-1/2 IN.
1 .....	60087 .....	ROPE, FRONT POINTER 1/4 IN.
2 .....	15081 .....	GRIPS, HANDLE BAR 1 IN.
1 .....	06922-003 .....	BLADE SHAFT NUT, RIGHT SIDE
1 .....	07038-016 .....	BLADE SHAFT NUT, LEFT SIDE
1 .....	26928-002 .....	OUTER BLADE FLANGE
3 .....	17210ZE3505 .....	ELEMENT, AIR CLEANER
3 .....	9807956846 .....	SPARK PLUG
1 .....	17620ZH7023 .....	CAP, FUEL TANK
1 .....	28462ZV7003 .....	ROPE, RECOIL STARTER

# MQ SP2 SLAB SAW — NAME PLATE AND DECALS

NAME PLATE AND DECALS.

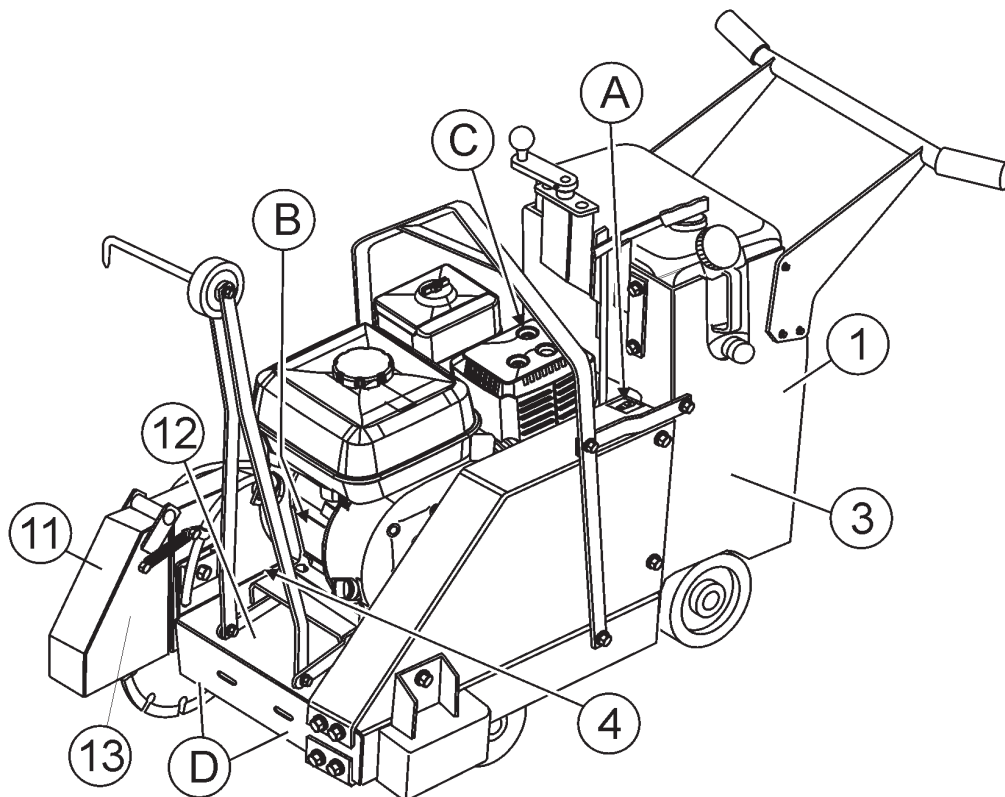
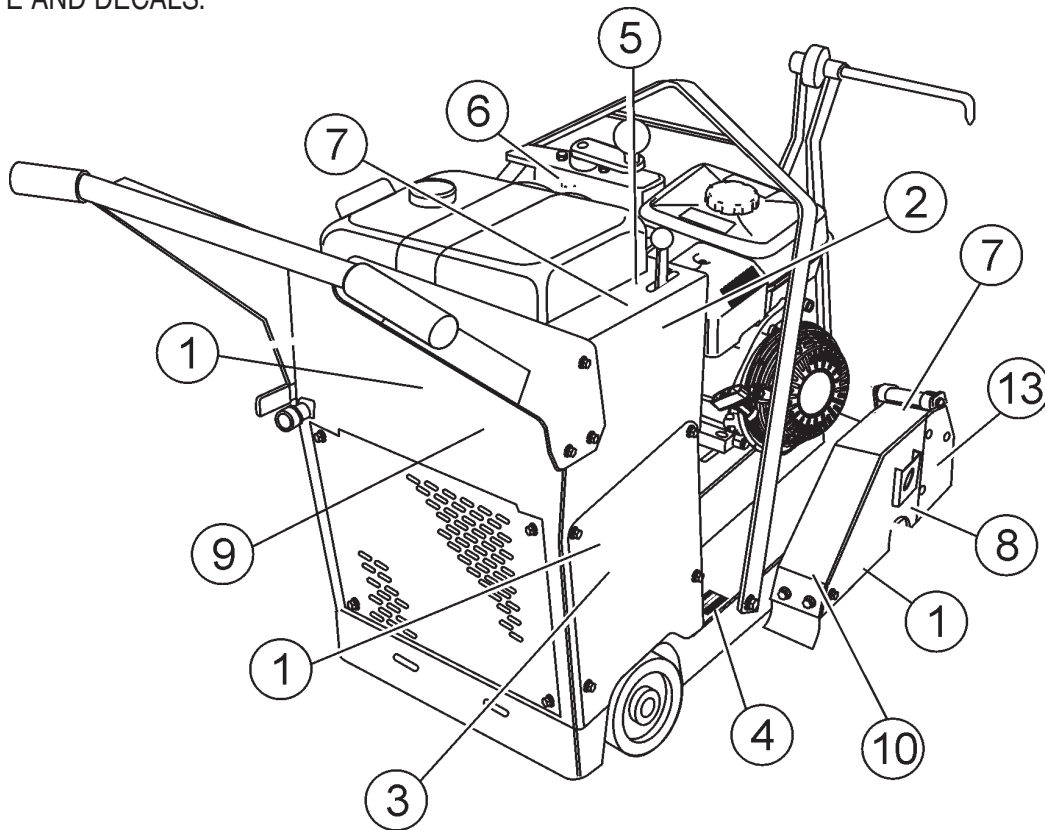

# MQ SP2 SLAB SAW — NAME PLATE AND DECALS

## NAME PLATE AND DECALS

<u>NO</u>	<u>PART NO</u>	<u>PART NAME</u>	<u>QTY.</u>	<u>REMARKS</u>
1	25782	DECAL, MQ DIAMONDBACK	4	
2	23596-001	DECAL, RECOMMENDED MAINTENANCE	1	
3	25784	DECAL, SP2	2	
4		NAMEPLATE .....	1	..... CONTACT MQ PARTS DEPT.
5	28853-001	DECAL, FORWARD/REVERSE LEVER	1	
6	20525	DECAL, PROP. 65	1	
7	22122-001	DECAL, SERIOUS INJURY WARNING	1	
8	25491	DECAL, CW ROTATION	1	
9	35137	DECAL, READ	1	
10	25260-001	DECAL, KEEP FEET CLEAR WARNING	1	
11	25249-001	DECAL, KEEP HANDS CLEAR WARNING	1	
12	13118	DECAL, POWDER COATED	1	
13	23330-001	DECAL, BELT GUARD CAUTION	2	
A	11246	DECAL, BELT DRIVE	1	
B	11246	DECAL, CHECK OIL LEVEL	1	
C	11246	DECAL, HOT	1	
D	11246	DECAL, LUBRICATION	2	

# MQ SP2 SLAB SAW — UNDER CARRIAGE ASSY.

UNDER CARRIAGE ASSY.

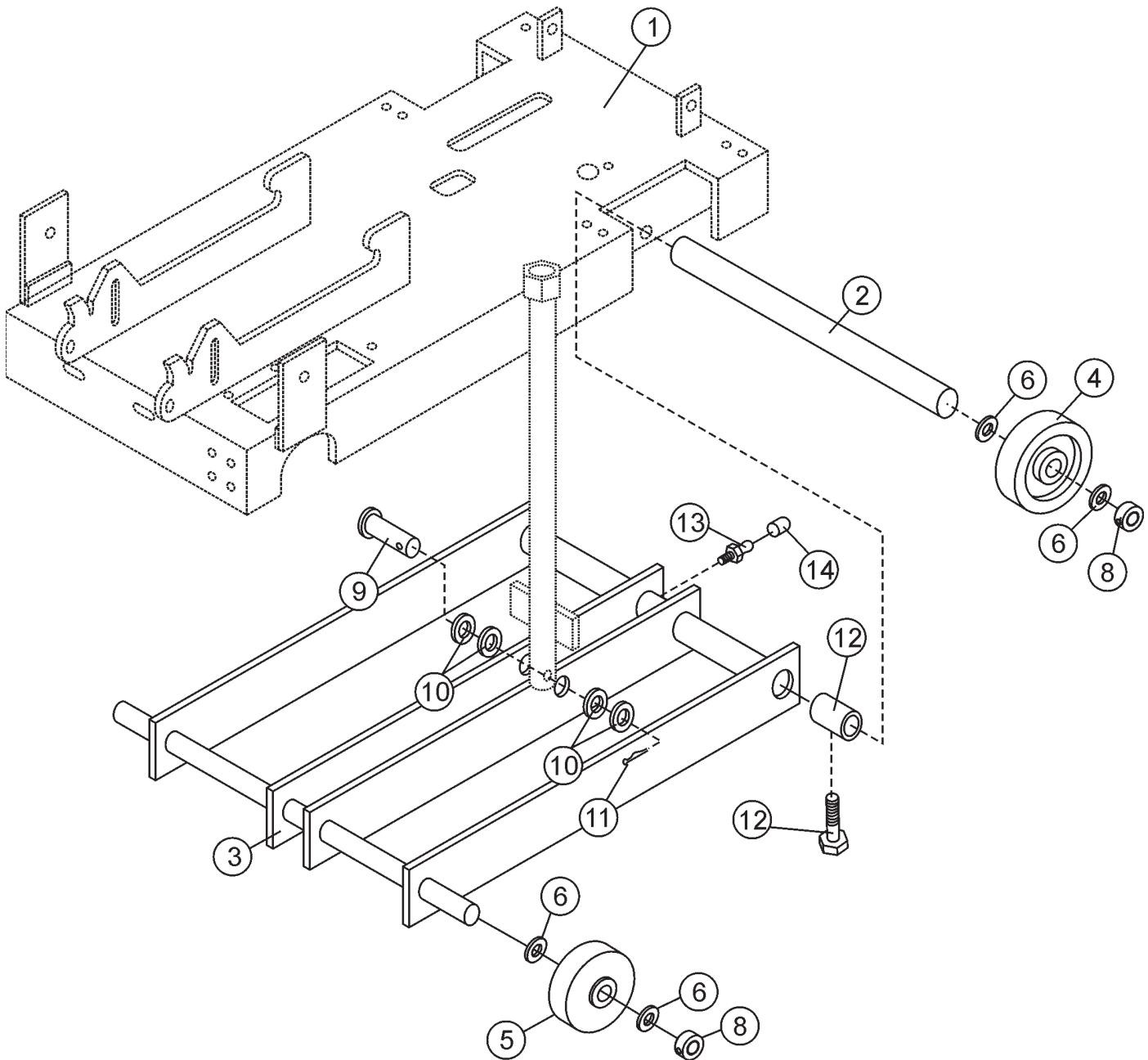

## MQ SP2 SLAB SAW — UNDER CARRIAGE ASSY.

### UNDERCARRIAGE ASSY.

<u>NO</u>	<u>PART NO</u>	<u>PART NAME</u>	<u>QTY.</u>	<u>REMARKS</u>
1	28777-352	FRAME ASSY. 16"/18"/20"	1	
2	28781-002	AXLE, REAR & FRONT	1	
3	28782-351	FRAME, UNDERCARRIAGE ASSY.	1	
4	28086-001	WHEEL, 8 X 2 .75 ROLLER BEARING REAR	2	
5	28085-001	WHEEL, 5 X 2 .75 ROLLER BEARING FRONT	2	
6	8151	WASHER, FLAT SAE 3/4	8	
7	10065-090	BEARING PLAIN	2	
8	25181-001	COLLAR, SET 0.75 X 1.50 X .50, SPLIT	4	
9	8081	PIN, CLEVIS 1/2 X 2-3/4	1	
10	0447	WASHER, FLAT SAE 1/2	4	
11	3216	PIN, COTTER 1/8D X 1	1	
12	0685	SCREW, SHS 5/16-18 X 5/16	2	
13	2621	ZERK, GREASE STR. 1/4-28	1	
14	1162 A	CAP, ZERK FITTING	1	

# MQ SP2 SLAB SAW — BLADE SHAFT ASSY.

## BLADE SHAFT ASSY.

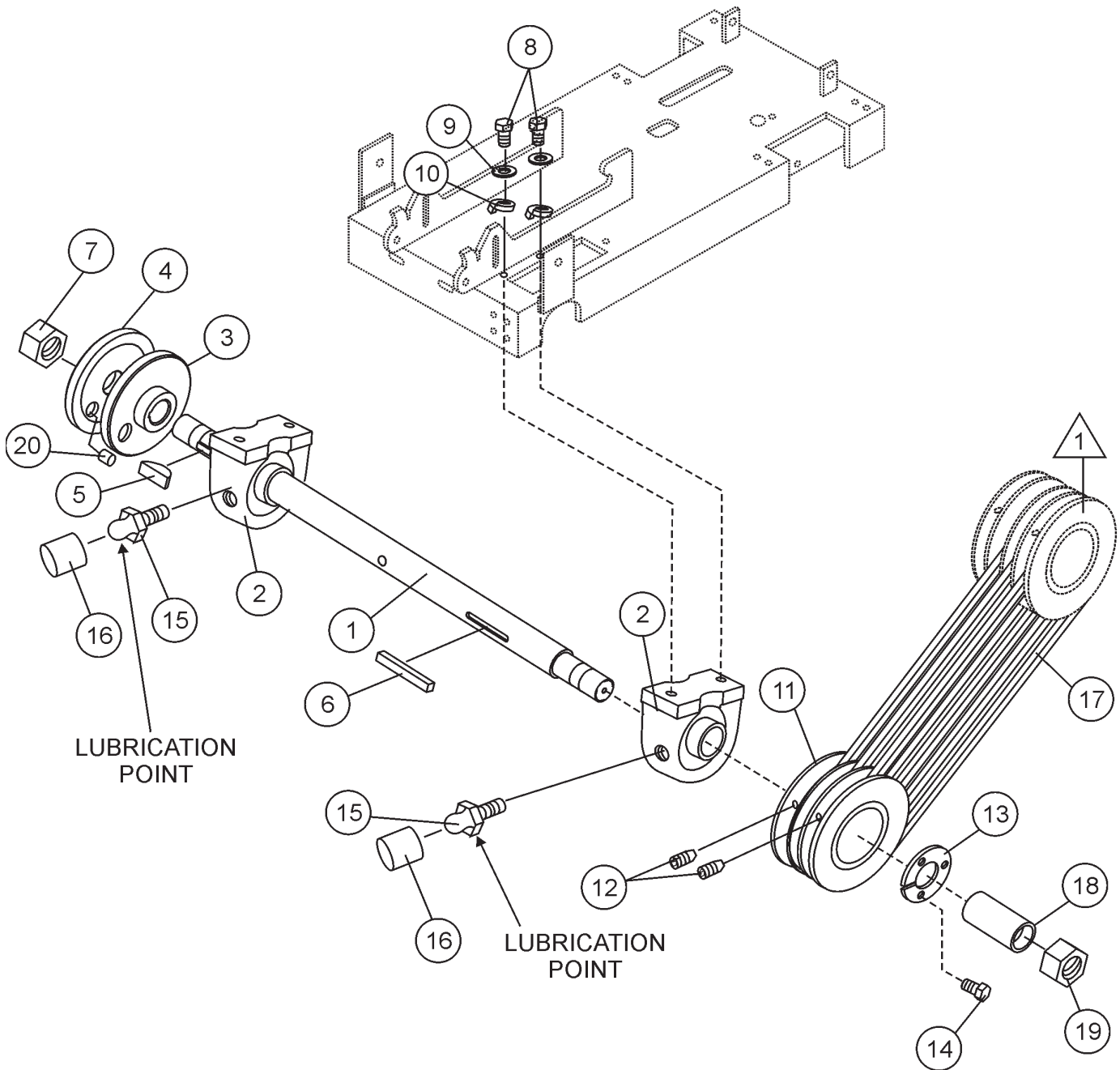

### NOTES:

- △ 1 ENGINE PULLEY,  
13HP & 20HP HONDA  
ENGINE ASSY., ITEM 2



# MQ SP2 SLAB SAW — BLADE SHAFT ASSY.

## BLADE SHAFT ASSY.

<u>NO</u>	<u>PART NO</u>	<u>PART NAME</u>	<u>QTY.</u>	<u>REMARKS</u>
1	28807-002	SPINDLE, BLADE	1	
2	28081-001	BEARING, PILLOW BLOCK 1.25ID AS206-20	2	
3	28811-002	FLANGE, BLADE INSIDE 4.0OD X 1.0ID	1	
4	26928-002	FLANGE, BLADE OUTSIDE 1.0ID X5.0OD X 56	1	
	26928-004	FLANGE, BLADE OUTSIDE 1.0ID X4.0OD X 56	1	
5	0125	KEY, WOODRUFF #15	1	
6	6059 B	KEY, 1/4"SQ. X 2", 1018 STOCK	1	
7	06922-003	NUT, HEX JAM LH 1-14 PLATED	1	
8	06502-012	SCREW, HHC 7/16-14 X 1-1/2	4	
9	2955	WASHER, LOCK 7/16 ZINC	4	
10	0448	WASHER, FLAT SAE 7/16	4	
11	25172-003	PULLEY, BLADE SHAFT, 3F3V33X112 .....	1	13 HP PUSH & 20 IN. SELF-PROP. MODELS
11	23280-001	PULLEY, BLADE SHAFT, 43V4.12 .....	1	20 IN. SELF-PROP. MODELS
12	1528	SCREW, SHS	2	
13	28841-001	BUSHING, SPLIT TYPE	1	
14	0424	SCREW, 1/4-20 X 1-1/4	3	
15	2621	ZERK FITTING	2	
16	1162 A	CAP,GREASE ZERK, #2 RED	2	
17	16052	V-BELT, 3V x 335 .....	3	13 HP PUSH & SELF-PROP. MODELS
17	15897	V-BELT, 3V x 355	4	
18	23250-002	SPACER, SPINDLE	1	
19	07038-016	NUT, HEX JAM 1"-14 PLATED	1	
20	15046	PIN, DOWEL 3/8 x 1-1/4 LG	1	

# MQ SP2 SLAB SAW — LIFTING BALE ASSY.

LIFTING BALE ASSY.

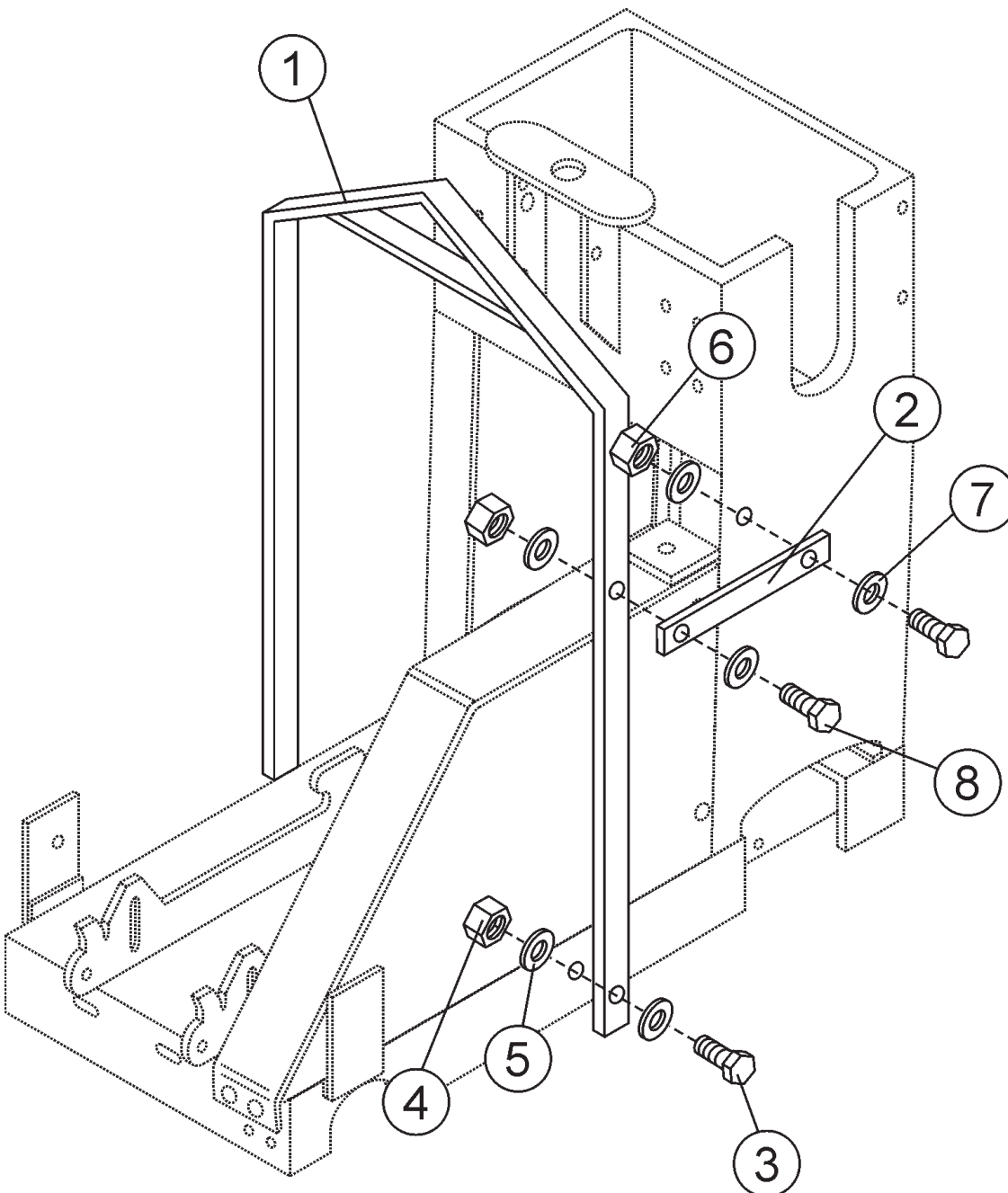

## MQ SP2 SLAB SAW — LIFTING BALE ASSY.

### LIFTING BALE ASSY.

<u>NO</u>	<u>PART NO</u>	<u>PART NAME</u>	<u>QTY.</u>	<u>REMARKS</u>
1	28890-351	13HP, LIFT BALE ASSY.	1	
1	28890-352	20HP, LIFT BAIL ASSY.	1	
2	28893-001	BRACE, 13HP BAIL	1	
2	28893-002	BRACE, 20HP BAIL	1	
3	0205	SCREW, HHC 3/8-16 X 1.0	2	
4	10133	NUT, NYLOC 3/8-16	2	
5	10136	WASHER, FLAT SAE 3/8	4	
6	5283	NUT, NYLOC 5/16-18	2	
7	0300 B	WASHER, FLAT SAE 5/16	4	
8	0202	SCREW, HHC 5/16-18 X 1 ZINC	2	

# MQ SP2 SLAB SAW — CONSOLE ASSY. (PUSH MODELS)

CONSOLE ASSY. (PUSH MODELS)

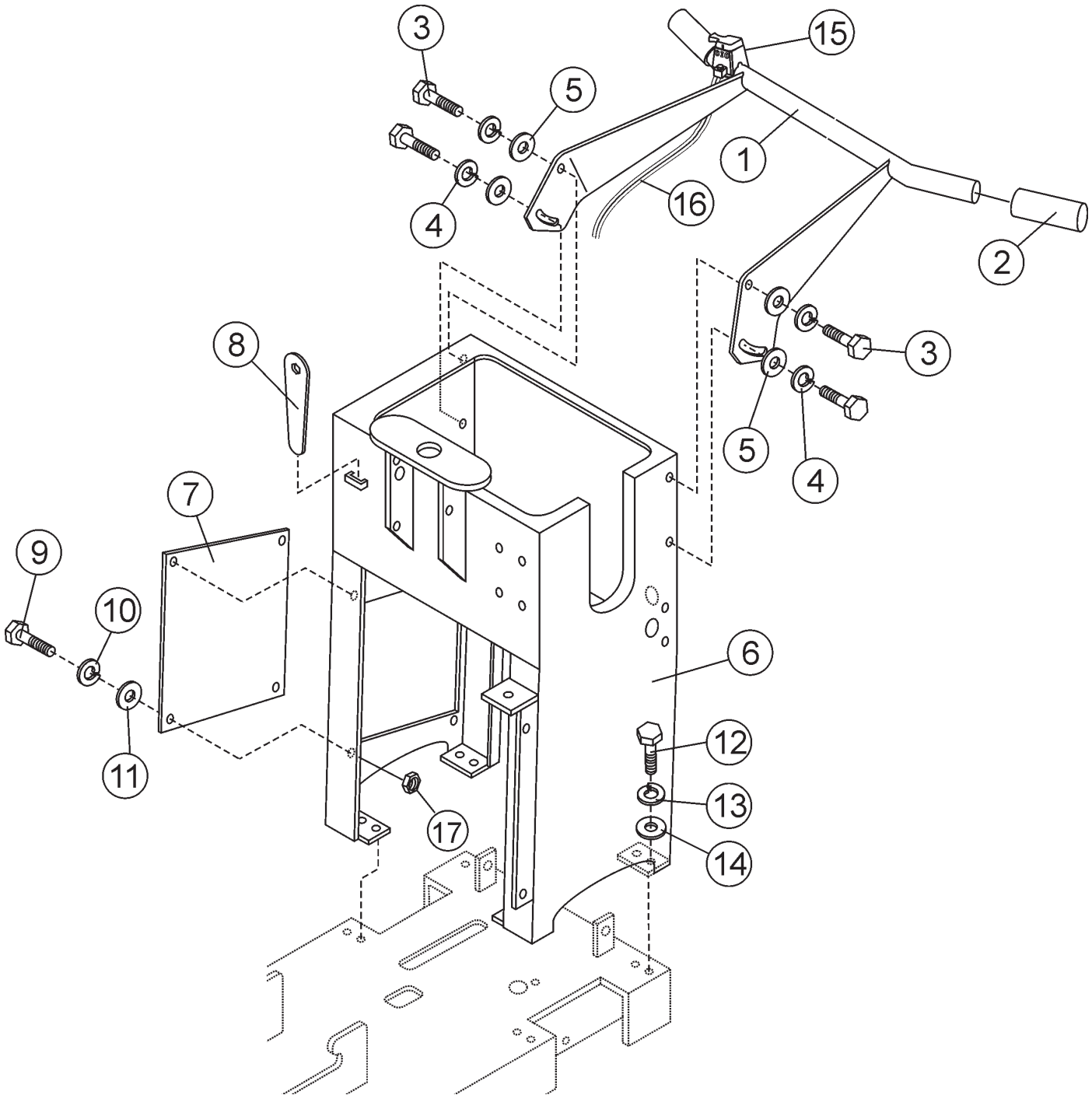

# MQ SP2 SLAB SAW — CONSOLE ASSY. (PUSH MODELS)

## CONSOLE ASSY. PUSH

<u>NO</u>	<u>PART NO</u>	<u>PART NAME</u>	<u>QTY.</u>	<u>REMARKS</u>
1	28796-351	HANDLE ASSY.	1	
2	15081	GRIP, 1"ID, H/W #40001610055	2	
3	4196	SCREW, HHC 3/8-16 X .75	4	
4	0166 A	WASHER, LOCK 3/8 MED.	4	
5	10136	WASHER, FLAT SAE 3/8	4	
6	28791-751	HOUSING ASSY. - RED	1	
7	28805-701	COVER, CONSOLE SIDE - RED	1	
8	29013-001	WRENCH, BOX END 1 1/2	1	
9	1579	SCREW, HHC 1/4-20 X 1/2	4	
10	0181 B	WASHER, LOCK 1/4 MED.	8	
11	0948	WASHER, FLAT SAE 1/4	4	
12	0205	SCREW, HHC 3/8-16 X 1.0	8	
13	0166 A	WASHER, LOCK 3/8 MED.	8	
14	4001	WASHER, FLAT USS 3/8 PLD	8	
15	35127	SWITCH, ENGINE ON/OFF .....	1	SAFETY ITEM
16	35200	WIRE, ENGINE ON/OFF SWITCH .....	1	SAFETY ITEM
17	19266	BLIND NUT, 1/4-20	4	

# MQ SP2 SLAB SAW — CONSOLE ASSY. (SELF-PROPELLED MODELS)

CONSOLE ASSY. (SELF- PROPELLED MODELS)

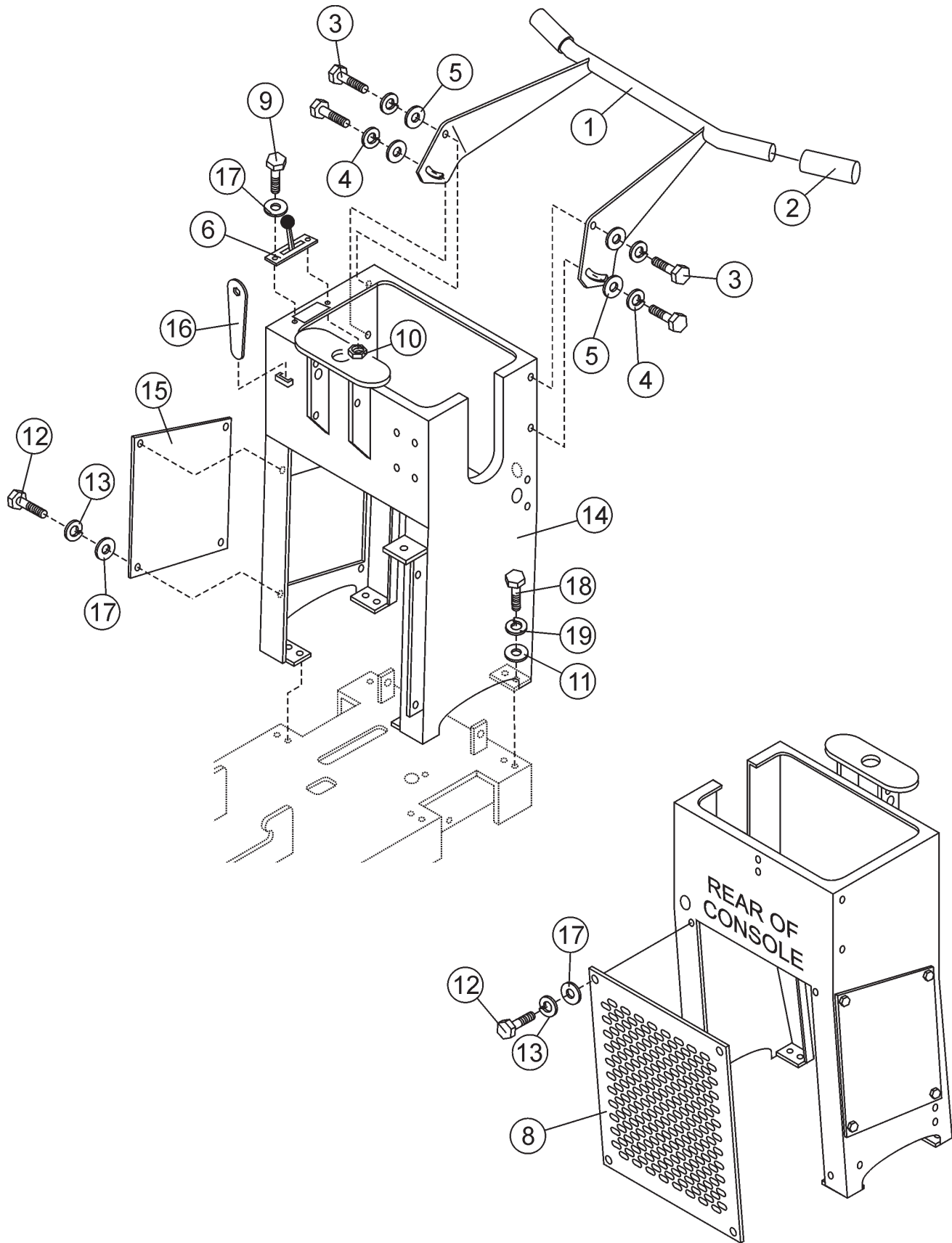

# MQ SP2 SLAB SAW — CONSOLE ASSY. (SELF-PROPELLED MODELS)

## CONSOLE ASSY. (SELF- PROPELLED MODELS)

<u>NO</u>	<u>PART NO</u>	<u>PART NAME</u>	<u>QTY.</u>	<u>REMARKS</u>
1	28796-351	HANDLE ASSY.	1	
2	15081	GRIP, 1" ID	2	
3	4196	SCREW, HHC 3/8-16 X .75	4	
4	0166 A	WASHER, LOCK 3/8 MED.	4	
5	10136	WASHER, FLAT SAE 3/8	4	
6	28091-401	SHIFT CONTROL ASSY.	1	
8	28834-001	COVER, REAR	1	
9	0131 A	SCREW, HHC 1/4-20 X 3/4	2	
10	1002 4	NUT, NYLOC 1/4-20	2	
11	4001	WASHER, FLAT USS 3/8 PLD	8	
12	1579	SCREW, HHC 1/4-20 X 1/2	8	
13	0181 B	WASHER, LOCK 1/4 MED.	8	
14	28791-751	HOUSING ASSY. - RED	1	
15	28805-701	COVER, CONSOLE SIDE, - RED	1	
16	29013-001	WRENCH, BOX END 1 1/2	1	
17	0948	WASHER, FLAT SAE 1/4	4	
18	0205	SCREW, HHC 3/8-16 X 1.0	8	
19	0166 A	WASHER, LOCK 3/8 MED.	8	

# MQ SP2 SLAB SAW — 13HP HONDA ENGINE MOUNT ASSY.

13HP HONDA ENGINE MOUNT ASSY.

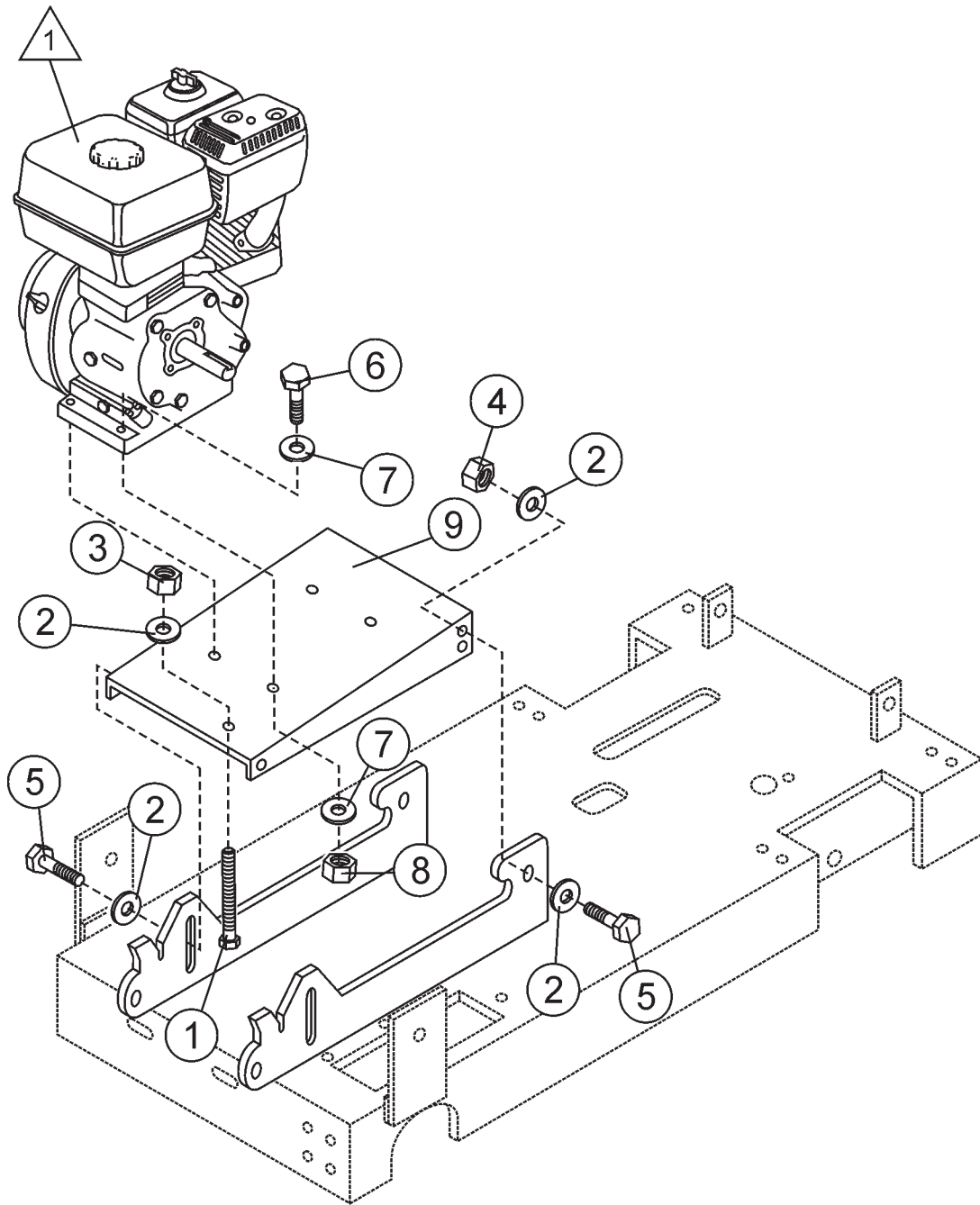

## NOTES:

 ENGINE SHOWN FOR  
MOUNTING PURPOSE ONLY  
ENGINE MAY NOT LOOK  
LIKE ILLUSTRATION



## MQ SP2 SLAB SAW — 13HP HONDA ENGINE MOUNT ASSY.

13HP HONDA ENGINE MOUNT ASSY.

<u>NO</u>	<u>PART NO</u>	<u>PART NAME</u>	<u>QTY.</u>	<u>REMARKS</u>
1	15868-032	SCREW, SQHS 1/2-13 X 4, CUP PLAIN	1	
2	0447	WASHER, FLAT SAE 1/2	9	
3	968011	NUT, HEX FINISH 1/2-13	1	
4	10176	NUT, NYLOC 1/2-13	4	
5	3214	SCREW, HHC 1/2-13 X 1 1/4	4	
6	9154	SCREW, HHC 3/8-16 X 1 3/4	4	
7	10136	WASHER, FLAT SAE 3/8	8	
8	10133	NUT, NYLOC 3/8-16	4	
9	28804-351	ENGINE BASE ASSY.	1	

# MQ SP2 SLAB SAW — 20HP HONDA ENGINE MOUNT ASSY.

20HP HONDA ENGINE MOUNT ASSY.

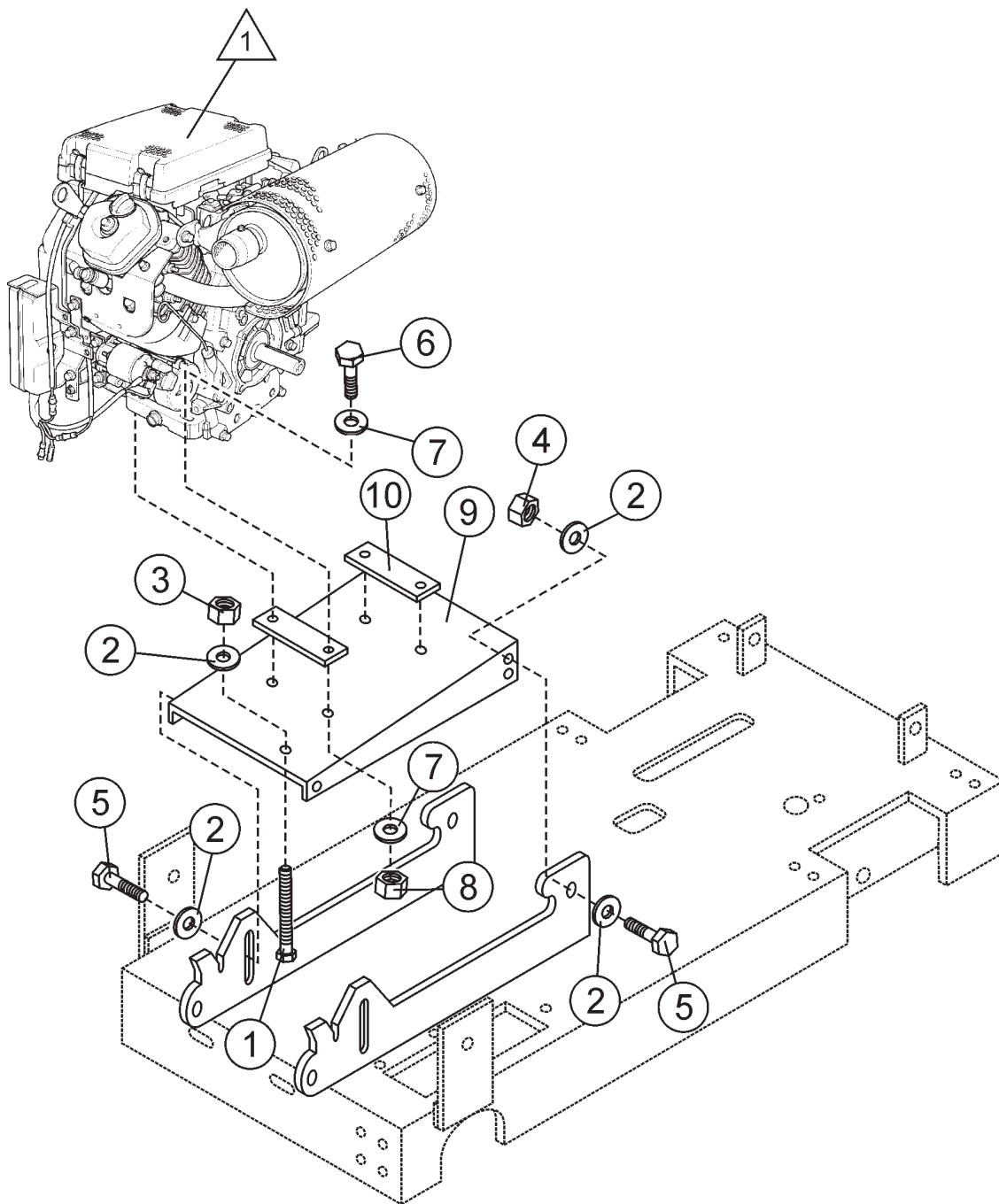

## NOTES:

 ENGINE SHOWN FOR MOUNTING PURPOSE ONLY  
ENGINE MAY NOT LOOK LIKE ILLUSTRATION

## MQ SP2 SLAB SAW — 20HP HONDA ENGINE MOUNT ASSY.

20HP HONDA ENGINE MOUNT ASSY.

<u>NO</u>	<u>PART NO</u>	<u>PART NAME</u>	<u>QTY.</u>	<u>REMARKS</u>
1	15868-032	SCREW, SQHS 1/2-13 X 4, CUP PLAIN	1	
2	0447	WASHER, FLAT SAE 1/2	9	
3	968011	NUT, HEX FINISH 1/2-13	1	
4	10176	NUT, NYLOC 1/2-13	4	
5	3214	SCREW, HHC 1/2-13 X 1 1/4	4	
6	4370	SCREW, HHC 3/8-16 X 2 1/4	4	
7	10136	WASHER, FLAT SAE 3/8	8	
8	10133	NUT, NYLOC 3/8-16	4	
9	28804-351	ENGINE BASE ASSY.	1	
10	27044-001	SPACER	2	

# MQ SP2 SLAB SAW — 13HP HONDA ENGINE ASSY.

13HP HONDA ENGINE ASSY.

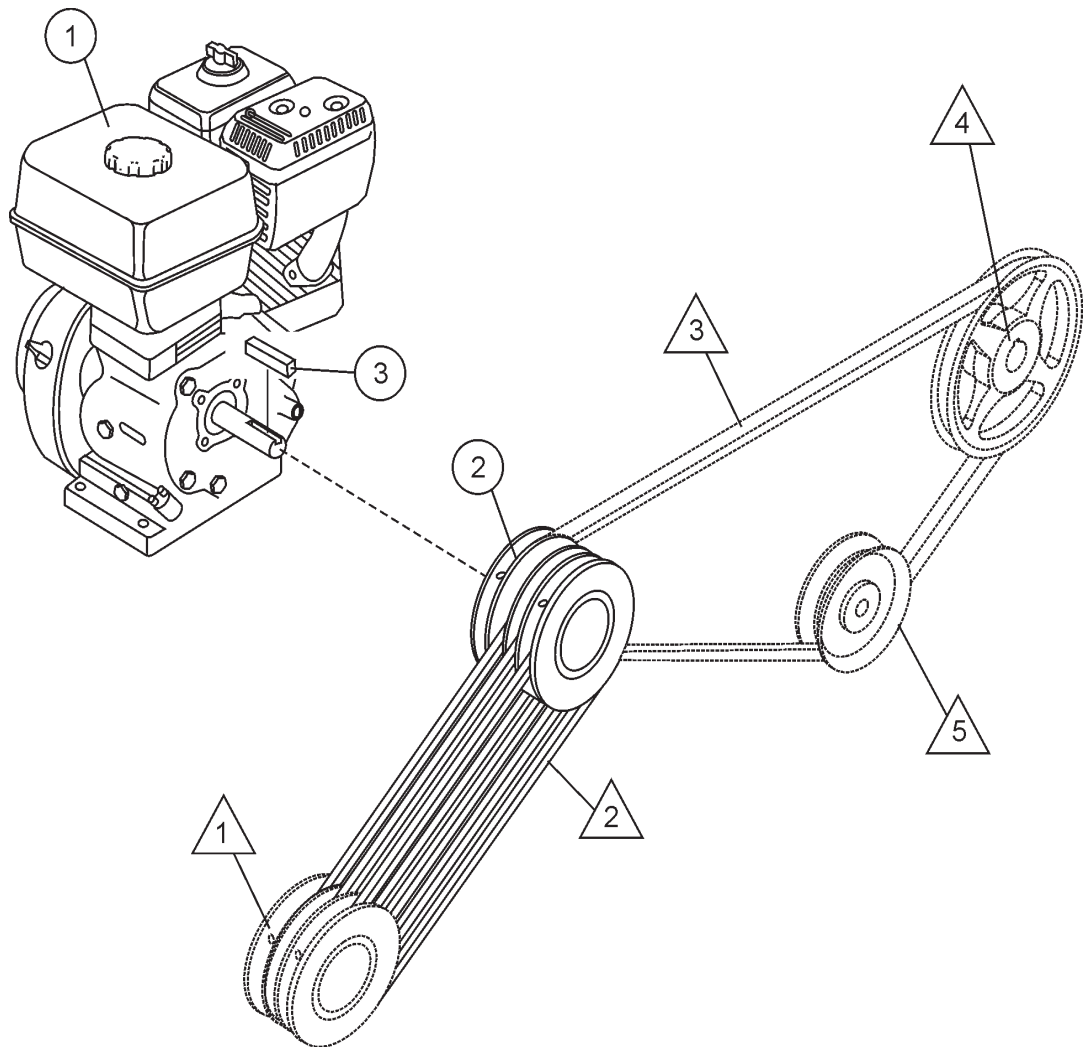

## NOTES:



SEE BLADE SHAFT  
ASSY., ITEM 11



SEE HYDROSTATIC DRIVE  
ASSY., ITEM 14



SEE BLADE SHAFT  
ASSY., ITEM 17



SEE HYDROSTATIC DRIVE  
ASSY., ITEM 15



SEE HYDROSTATIC DRIVE  
ASSY., ITEM 25

# MQ SP2 SLAB SAW — 13HP HONDA ENGINE ASSY.

13HP HONDA ENGINE ASSY.

<u>NO</u>	<u>PART NO</u>	<u>PART NAME</u>	<u>QTY.</u>	<u>REMARKS</u>
1	15103	ENGINE, HONDA 13HP, GX390K1QWT2	1	
2	23665-001	PULLEY, ENGINE 13 HP, 3F3V26X1 .....	1 .....	13HP PUSH MODELS
2	23703-003	PULLEY, ENGINE 13 HP, 4F3V26X1	1	13HP SELF-PROP MODELS
3	6059 B	KEY 1/4" SQ. X 2, 1018 STOCK	1	

# MQ SP2 SLAB SAW — 20HP HONDA ENGINE ASSY.

20HP HONDA ENGINE ASSY.

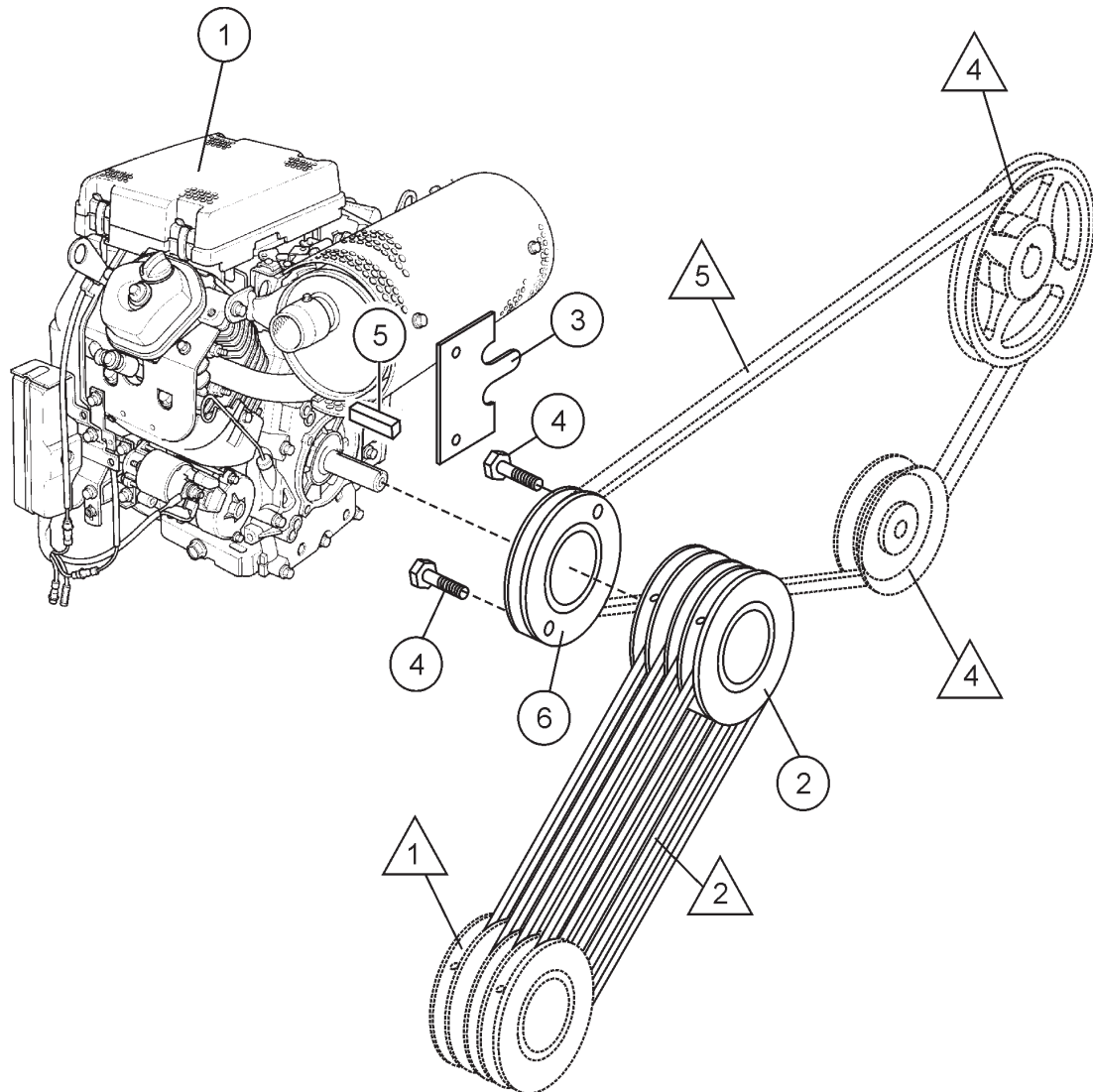

## NOTES:

- |     |                                |     |                                      |
|-----|--------------------------------|-----|--------------------------------------|
| △ 1 | SEE BLADE SHAFT ASSY., ITEM 11 | △ 3 | SEE HYDROSTATIC DRIVE ASSY., ITEM 14 |
| △ 2 | SEE BLADE SHAFT ASSY., ITEM 17 | △ 4 | SEE HYDROSTATIC DRIVE ASSY., ITEM 15 |
|     |                                | △ 5 | SEE HYDROSTATIC DRIVE ASSY., ITEM 25 |

# MQ SP2 SLAB SAW — 20HP HONDA ENGINE ASSY.

20HP HONDA ENGINE ASSY.

<u>NO</u>	<u>PART NO</u>	<u>PART NAME</u>	<u>QTY.</u>	<u>REMARKS</u>
1	15104	ENGINE, HONDA 20HP GX620TXF2	1	
2	28833-002	PULLEY, ENGINE C3 20H20, 4F3V412	1	
3	28099-001	MOUNT, IDLER SPRING	1	
4	923203	SCREW, SHC 1/4-20 X 3/4	2	
5	6059 B	KEY 1/4" SQ. X 2, 1018 STOCK	1	
6	28088-002	PULLEY, TRANSMISSION	2	

# MQ SP2 SLAB SAW — POINTERS AND COVERS ASSY.

## POINTERS AND COVERS ASSY.

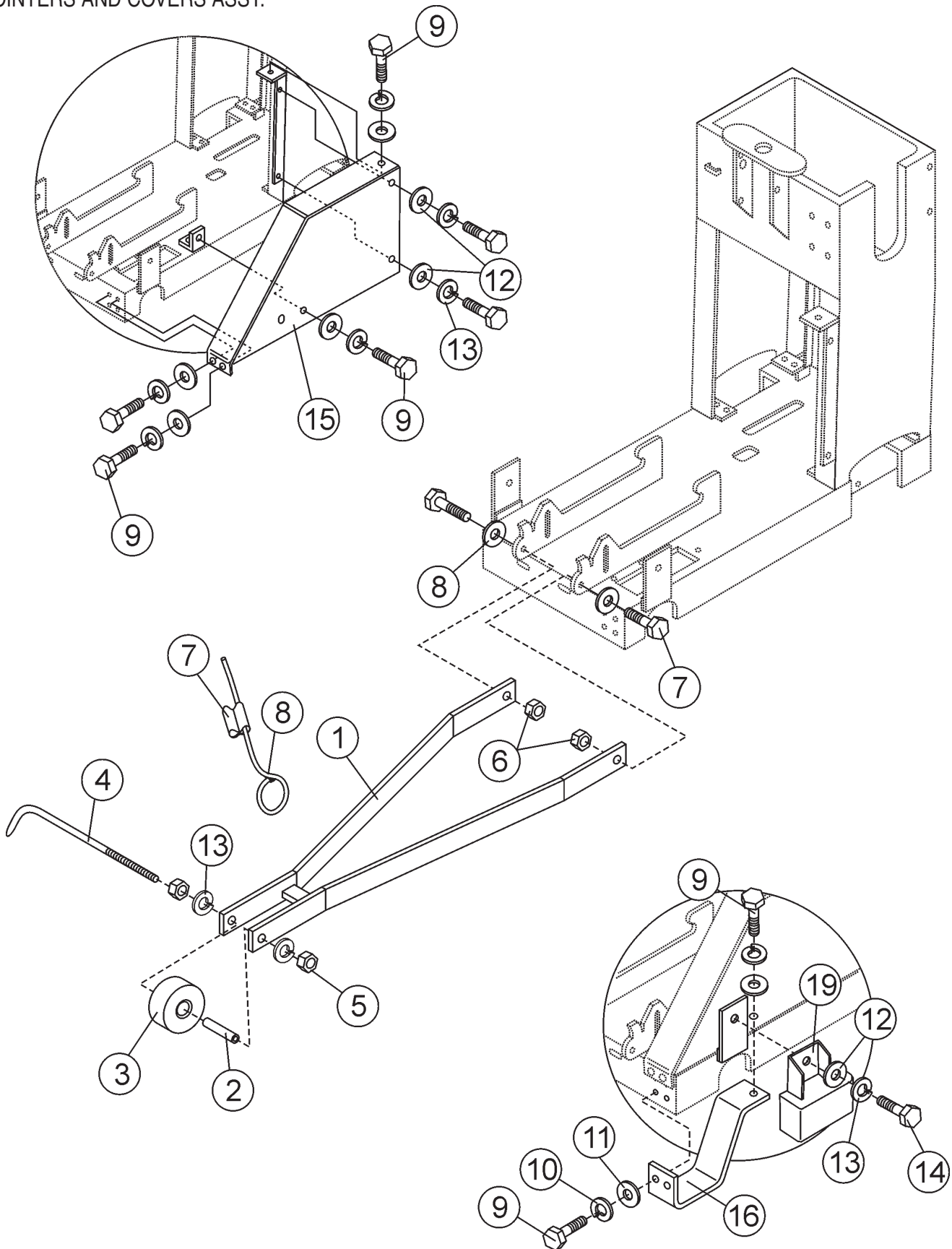



## MQ SP2 SLAB SAW — POINTERS AND COVERS ASSY.

### POINTER AND COVERS ASSY.

<u>NO</u>	<u>PART NO</u>	<u>PART NAME</u>	<u>QTY.</u>	<u>REMARKS</u>
1	28646-351	BLADE GUIDE WELDMENT	1	
2	28649-001	SPANNER BUSHING CSI	1	
3	28648-001	WHEEL, 3.00 X 1.25 .50 ID POLY CSI	1	
4	28647-001	POINTER	1	
5	1456	NUT, HEX FINISH 3/8-16	2	
6	10133	NUT, NYLOC 3/8-16	2	
7	15114	SLEEVE, SASH	2	
8	60087	ROPE, 1/4" NYLON, BRAIDED, WHITE	7	
9	0655	SCREW, HHC 5/16-18 X 3/4	7	
10	0161 C	WASHER, LOCK 5/16 MED.	7	
11	0300 B	WASHER, FLAT SAE 5/16	7	
12	10136	WASHER, FLAT SAE 3/8	3	
13	0166 A	WASHER, LOCK 3/8 MED.	3	
14	0205	SCREW, HHC 3/8-16 X 1.0	3	
15	28799-751	BELT GUARD, - RED	1	
16	28835-001	GUARD, PULLEY	1	
19	29745-754	SPINDLE GUARD ASSY. - RED	1	

# MQ SP2 SLAB SAW — WATER SYSTEM ASSY.

WATER SYSTEM ASSY.

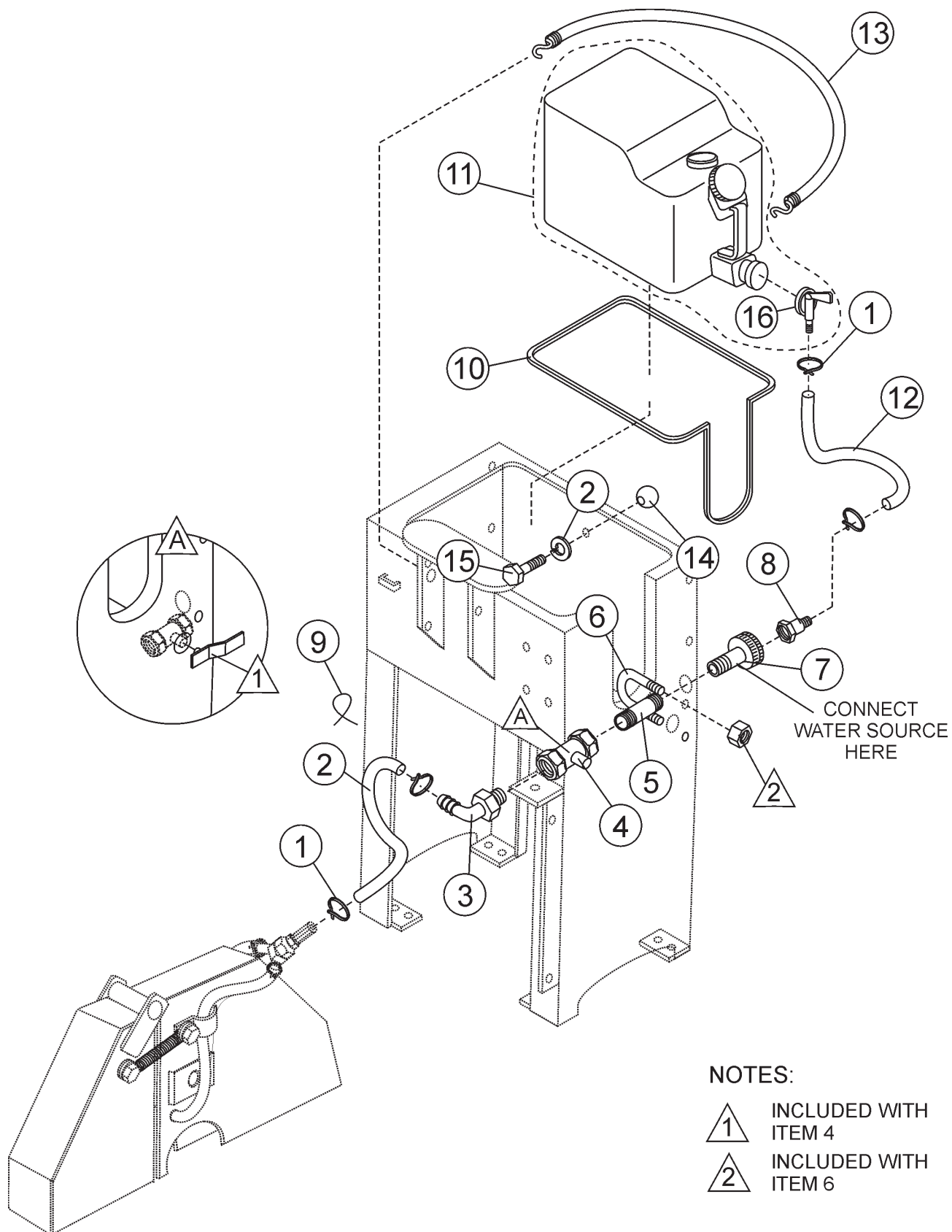

# MQ SP2 SLAB SAW — WATER SYSTEM ASSY.

## WATER SYSTEM FROM CONSOLE SP

<u>NO</u>	<u>PART NO</u>	<u>PART NAME</u>	<u>QTY.</u>	<u>REMARKS</u>
1	12694-008	HOSE CLAMP, SPRING TYPE 7/8 O.D HOSE	4	
2	23255-004	HOSE, WATER 1/2 X 37	1	
3	23566-001	FITTING, PLASTIC 90 1/2MP X 1/2BARB	1	
4	23259-001	VALVE, BALL 1/2 MPT BRASS NIBCO T585-70	1	
5	23254-001	FITTING, NIPPLE 1/2MP X 2 GALV.	1	
6	16378-009	U-BOLT W/NUTS	1	
7	15544	FITTING, BRASS 1/2FP-3/4F GRDN., STR	1	
8	24778-001	FITTING, BRASS 1/2 BARB X 3/4 GRDN	1	
9	1662	TIE, CABLE TY-RAP BLACK	2	
10	28861-501	TRIM KIT, WATER TANK RUBBER	1	
11	28089-001	TANK, 5 GAL. WATER .....	1	INCLUDES ITEM W/ *
12	27040-001	HOSE, 19 IN. VINYL WATER TANK	1	
13	28861-001	CORD, TANK RETAINER	1	
14	28860-001	KNOB	1	
15	06499-004	HHCS 1/4-20 x 1/2	1	
16*	28089-002	VALVE, WATER TANK (SPIGOT ONLY)	1	

# MQ SP2 SLAB SAW — BLADE GUARD ASSY.

BLADE GUARD ASSY.

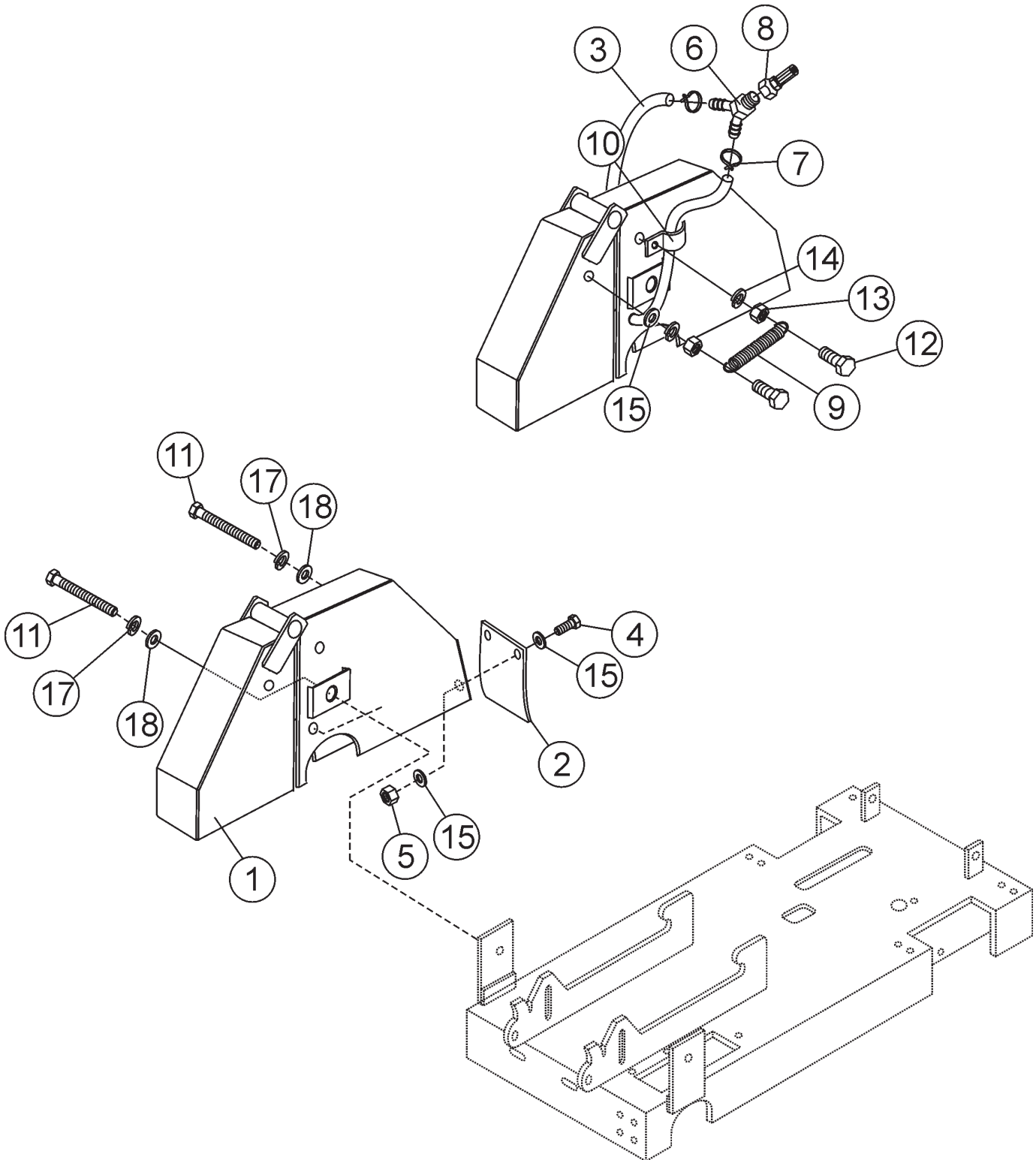

# MQ SP2 SLAB SAW — BLADE GUARD ASSY.

## BLADE GUARD ASSY.

<u>NO</u>	<u>PART NO</u>	<u>PART NAME</u>	<u>QTY.</u>	<u>REMARKS</u>
1	29406-754	BLADE GUARD W/A - RED	1	
2	28729-002	GUARD, SPLASH BLADE	1	
3	60021	HOSE, 3/8ID X 5/8OD BRAIDED PVC "PAC"	1.670	
4	0131 A	SCREW, HHC 1/4-20 X 3/4	2	
5	10024	NUT, NYLOC 1/4-20	2	
6	24642-001	Y-CONNECTOR 3/8	1	
7	12694-006	HOSE CLAMP, SPRING TYPE 3/4 O.D. HOSE	2	
8	24778-001	FITTING, BRASS 1/2BARB X 3/4F GRDN	1	
9	18626-001	SPRING TENSION, GUARD BLADE	2	
10	22129-001	PIPE STRAP 3/8	2	
11	21168	SCREW, HHC 3/8-16 X 4.75	1	
12	0424	SCREW, HHC 1/4-20 X 1 1/4	4	
13	0949	NUT, HEX FINISH 1/4-20 PLATED	4	
14	0181 B	WASHER, LOCK 1/4 MED.	4	
15	0948	WASHER, FLAT SAE 1/4	6	
16	0205	SCREW, HHC 3/8-16 X 1.0	1	
17	0166 A	WASHER, LOCK 3/8 MED.	2	
18	10136	WASHER, FLAT SAE 3/8	2	

# MQ SP2 SLAB SAW — MANUAL RAISE AND LOWER ASSY. (20 IN.)

## MANUAL RAISE AND LOWER ASSY. (20 IN.)

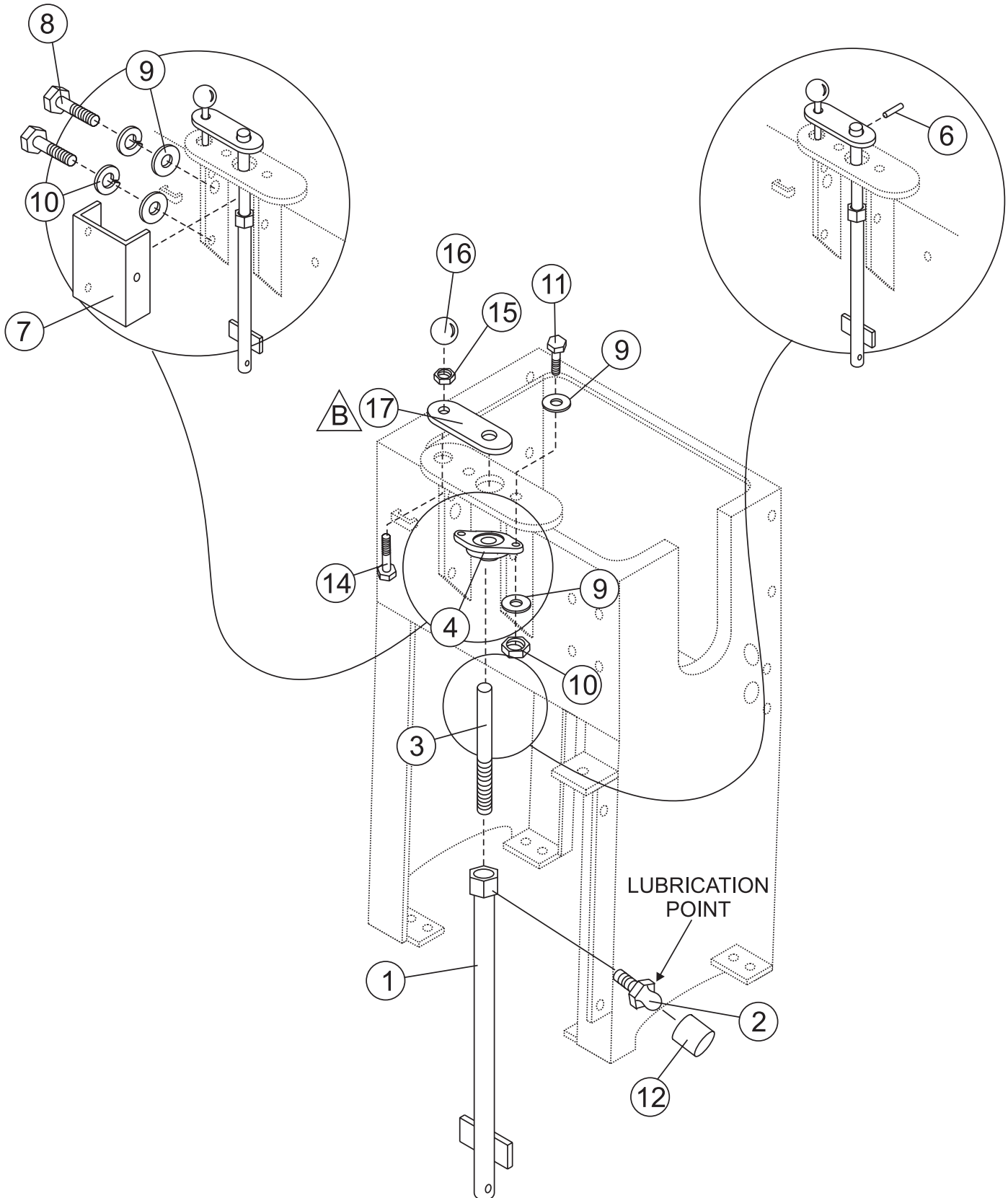

# MQ SP2 SLAB SAW — MANUAL RAISE AND LOWER ASSY. (20 IN.)

## JACK SCREW ASSY. 20" BLADE

<u>NO</u>	<u>PART NO</u>	<u>PART NAME</u>	<u>QTY.</u>	<u>REMARKS</u>
1	28793-352	JACKPOST ASSY.	1	
2	2621	ZERK, GREASE STR. 1/4-28	1	
3	28806-001	JACKSCREW	1	
4	28083-001	BEARING, FLANGE	1	
5	28809-001	SPACER, JACKSCREW	1	
6	4568	PIN, ROLL 3/16 X 1	1	
7	28877-751	SCREW COVER ASSY., RED	1	
8	1579	SCREW, HHC 1/4-20 X 1/2	3	
9	0948	WASHER, FLAT SAE 1/4	7	
10	0181 B	WASHER, LOCK 1/4 MED.	3	
11	0730	SCREW, HHC 1/4-20 X 1	2	
12	1162 A	CAP,GREASE ZERK, #2	1	
13	10024	NUT, NYLOC 1/4-20	2	
14	1121	SCREW, HHC 3/8-16 X 2 3/4	1	
15	1876	NUT, HEX JAM 3/8-16 CLASS 2B	1	
16	4403	KNOB, SHIFT	1	
17	28808-002	ARM-CRANK	1	

# MQ SP2 SLAB SAW — BATTERY ASSY.

## BATTERY ASSY.

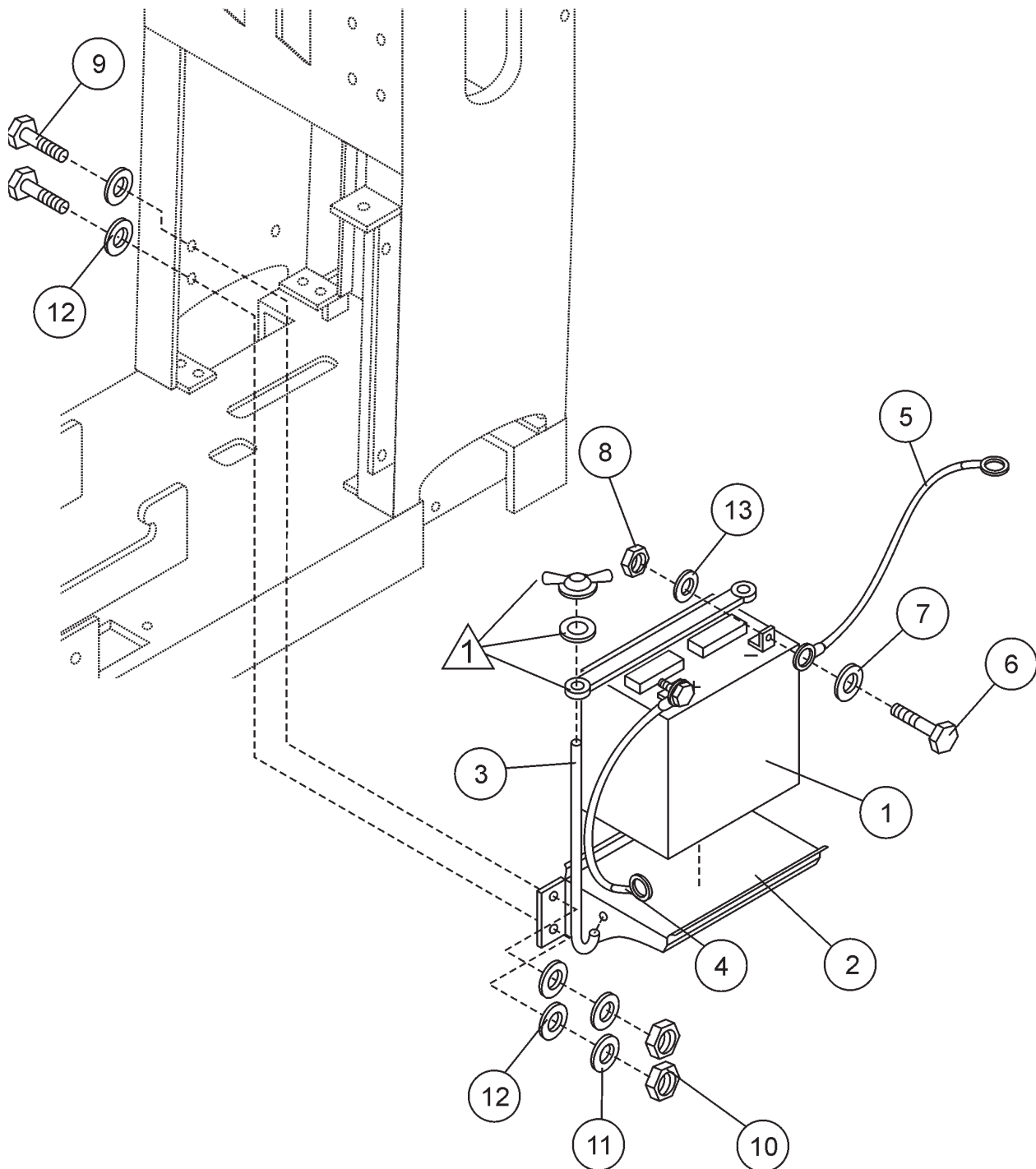

### NOTES:

 INCLUDED WITH  
ITEM 3



## MQ SP2 SLAB SAW — BATTERY ASSY.

### BATTERY ASSY.

<u>NO</u>	<u>PART NO</u>	<u>PART NAME</u>	<u>QTY.</u>	<u>REMARKS</u>
1	4671	BATTERY, WET GR.U1, GT-X GOLD LA	1	
2	28096-001	BRACKET BATTERY	1	
3	28095-401	BATTERY HOLD DOWN KIT 425-405	1	
4	28093-001	CABLE, BATTERY POS 6GA X 42" RING TONGUE	1	
5	28094-001	STRAP, GROUND	1	
6	0131 A	SCREW, HHC 1/4-20 X 3/4	2	
7	0948	WASHER, FLAT SAE 1/4	2	
8	0949	NUT, HEX FINISH 1/4-20 PLATED	2	
9	0655	SCREW, HHC 5/16-18 X 3/4	3	
10	0161 D	NUT, HEX FINISH 5/16-18	3	
11	0161 C	WASHER, LOCK 5/16 MED.	3	
12	0300 B	WASHER, FLAT SAE 5/16	6	
13	0181 B	WASHER, LOCK 1/4 MED.	2	

# MQ SP2 SLAB SAW — TRANSMISSION ENGAGE LEVER ASSY.

TRANSMISSION ENGAGE LEVER ASSY.

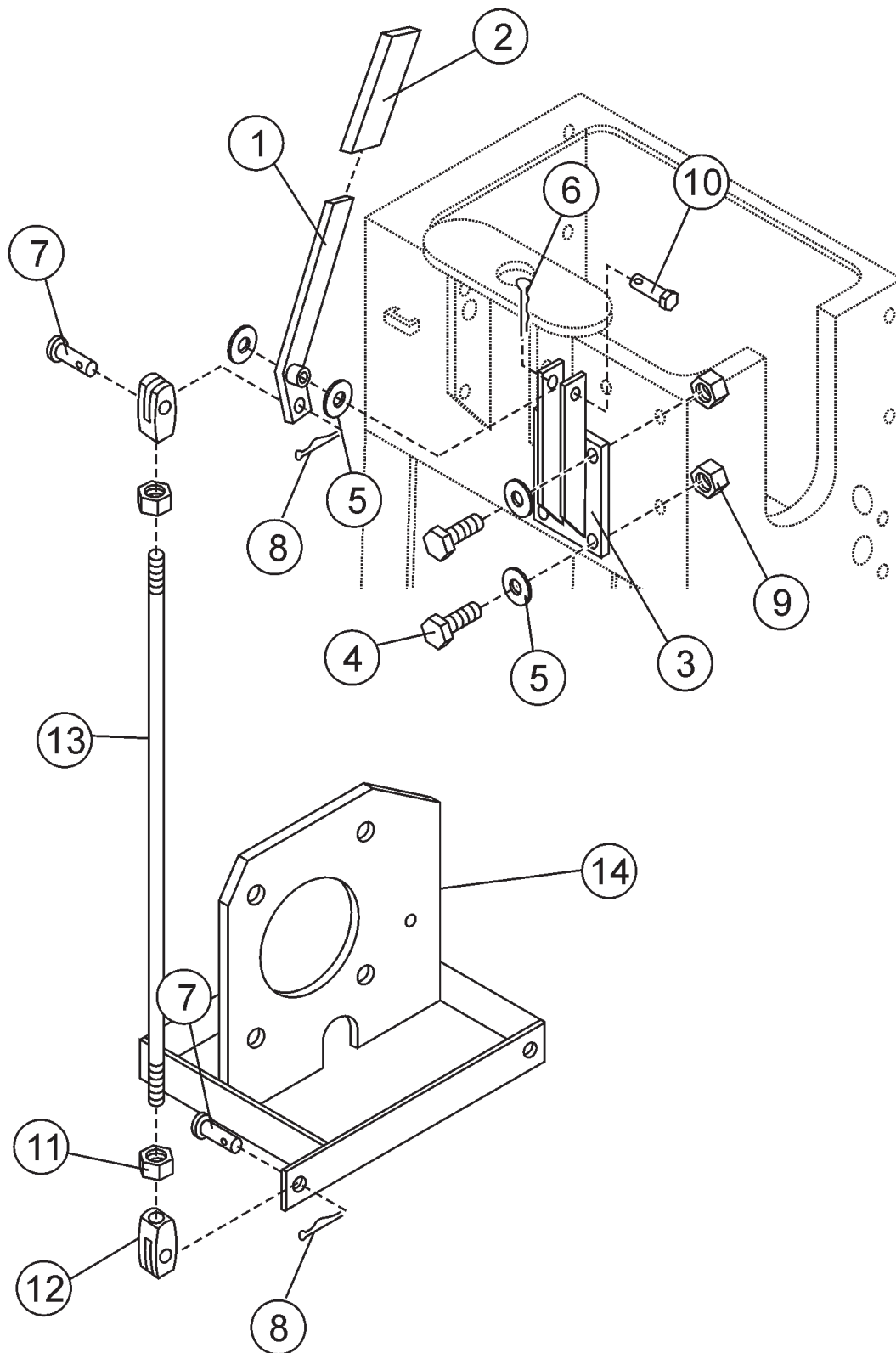

## MQ SP2 SLAB SAW — TRANSMISSION ENGAGE LEVER ASSY.

HYD. TRANSMISSION ENGAGE LEVER ASSY.

<u>NO</u>	<u>PART NO</u>	<u>PART NAME</u>	<u>QTY.</u>	<u>REMARKS</u>
1	28825-351	LEVER ASSY. TRANS. ENGAGE	1	
2	3360	GRIP, 1/4 X 1 BLACK	1	
3	28822-351	MOUNT ASSY., LEVER RED	1	
4	0655	SCREW, HHC 5/16-18 X 3/4	4	
5	10136	WASHER, FLAT SAE 3/8	6	
6	6014 B	PIN, COTTER 3/32D X 1.0	1	
7	08326-005	PIN, CLEVIS 5/16 X 1 O'ALL LENGHT PLATED	2	
8	07028-031	PIN, COTTER 3/32D X 1/2	2	
9	5283	NUT, NYLOC 5/16-18	8	
10	08326-019	PIN, CLEVIS 3/8 X 2" USEABLE LENGHT	1	
11	2199	NUT, HEX JAM 3/8-24	2	
12	08327-012	YOKE END, 3/8-24 X 2.50	2	
13	28830-001	ROD, TRANS. ENGINE	1	
14	28819-351	TRANS. BRACKET ASSY.	1	

# MQ SP2 SLAB SAW — HYDROSTATIC TRANSMISSION ASSY.

## HYDROSTATIC TRANSMISSION

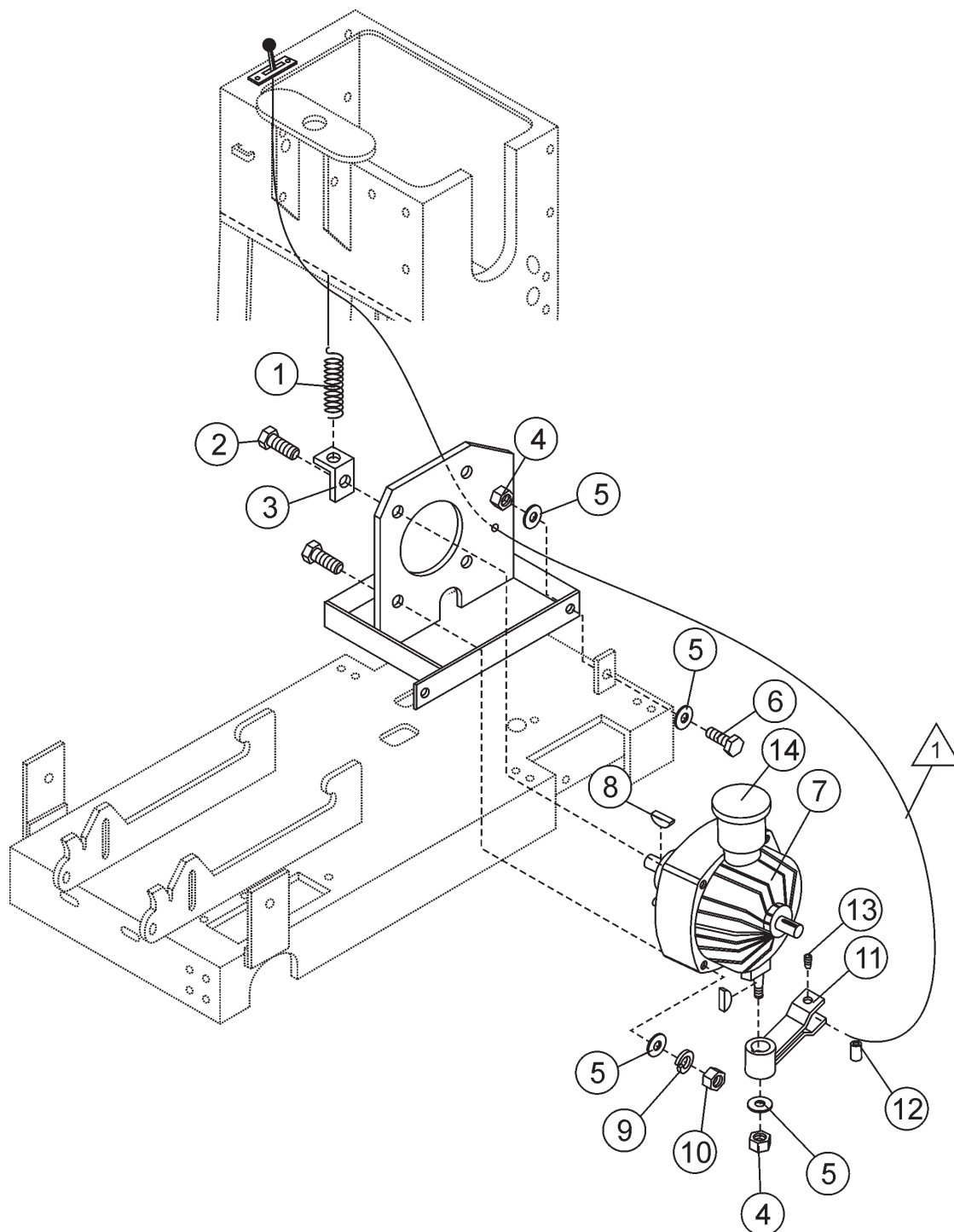

### NOTES:

-  INCLUDED WITH  
ITEM 6, CONSOLE ASSY.  
(SELF PROPELLED)

## MQ SP2 SLAB SAW — HYDROSTATIC TRANSMISSION ASSY.

### HYDROSTATIC TRANSMISSION ASSY.

<u>NO</u>	<u>PART NO</u>	<u>PART NAME</u>	<u>QTY.</u>	<u>REMARKS</u>
1	20559-001	SPRING, EXT. 3.38FL X 71OD X .105	1	
2	1493	SCREW, HHC 3/8-18 X 3.25	4	
3	28836-001	LINK, RETURN SPRING	1	
4	10133	NUT, NYLOC 3/8-16	7	
5	10136	WASHER, FLAT SAE 3/8	8	
6	1023	SCREW, HHC 3/8-16 X 1 1/4 GR 5	2	
7	15354	TRANSMISSION, HYD EATON	1	
8	1578	KEY, WOODRUFF #3	2	
9	0166 A	WASHER, LOCK 3/8 MED.	4	
10	1456	NUT, HEX FINISH 3/8-16	4	
11	28828-351	SHIFT ARM ASSY.	1	
12	28829-001	PIN, PIVOT	2	
13	10450	SCREW, SHS 10-32 X 1/4	1	
14	103530-000	CAP, TRANSMISSION	1	

# MQ SP2 SAW — HYDROSTATIC DRIVE ASSY.

## HYDROSTATIC DRIVE ASSY.

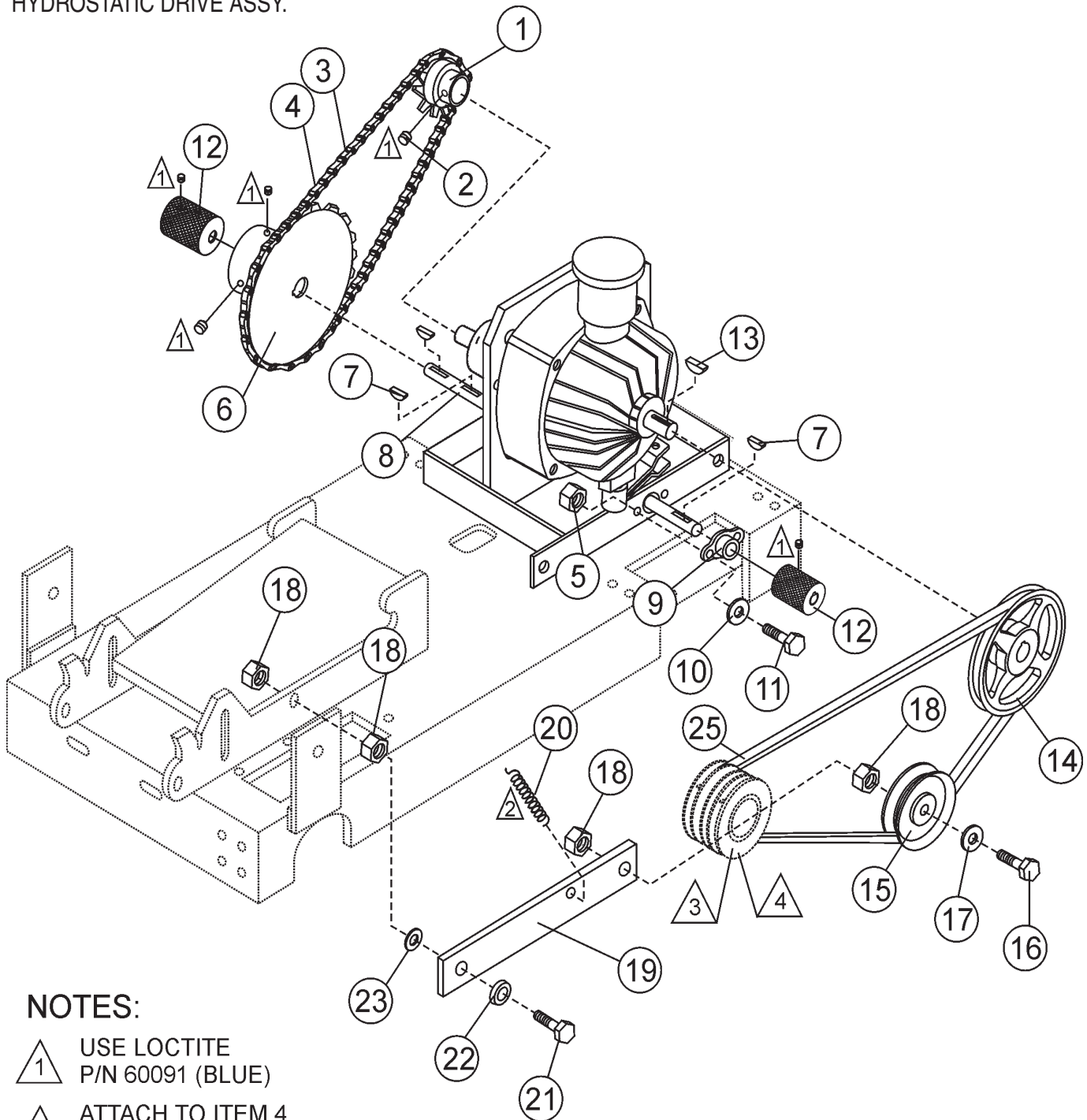

### NOTES:

- 1 USE LOCTITE  
P/N 60091 (BLUE)
- 2 ATTACH TO ITEM 4,  
20HP HONDA ENGINE ASSY.
- 3 SEE 13 HP ENGINE ASSY.,  
REQUIRES A 4-GROOVE  
PULLEY, ITEM 2.
- 4 SEE 20 HP ENGINE ASSY.,  
REQUIRES A SINGLE-GROOVE  
PULLEY, ITEM 6

# MQ SP2 SAW — HYDROSTATIC DRIVE ASSY.

## HYDROSTATIC DRIVE ASSY.

<u>NO</u>	<u>PART NO</u>	<u>PART NAME</u>	<u>QTY.</u>	<u>REMARKS</u>
1	23227-001	SPROCKET, TRANSMISSION 12 TOOTH MACH	1	
2	25039	SCREW, SHS 10-24 X 1/4	2	
3	23231-503	CHAIN, ROLLER .375 PITCH X 21.75	1	
4	10504-035	LINK, CHAIN	1	
5	5283	NUT, NYLOC 5/16-18	8	
6	28084-001	SPROCKET, 3548 X 3/4	1	
7	0126	KEY, WOODRUFF #9	3	
8	28832-001	JACKSHAFT	1	
9	23284-001	BEARING, FLANGE .34SQ x 3/4ID	2	
10	0300 B	WASHER, FLAT SAE 5/16	4	
11	2623	SCREW, HHC 5/16-18 X 1-1/4	4	
12	28831-001	GEAR, DRIVE	2	
13	1578	KEY, WOODRUFF #3	1	
14	28087-001	PULLEY, MA60 X 17MM	1	
15	25682-001	IDLER PULLEY	1	
16	9154	SCREW, HHC 3/8-16 X 1 3/4	1	
17	10136	WASHER, FLAT SAE 3/8	1	
18	10133	NUT, NYLOC 3/8-16	4	
19	23303-001	IDLER ARM	1	
20	23230-001	SPRING EXT. IDLE	1	
21	1284	SCREW, HHC 3/8-16 X 1 1/2	1	
22	18574-004	WASHER, BELLEVILLE 3/8	1	
23	28864-001	WASHER, FIBRE	1	
25	07055-050	V-BELT, TRANSMISSION 4L500 .....	1	..... 13HP SELF-PROP. MODELS
25	07055-051	V-BELT, TRANSMISSION 4L510 .....	1	..... 20HP SELF-PROP. MODELS

# HONDA GX390K1QWT2 ENGINE — AIR CLEANER ASSY.

AIR CLEANER ASSY.

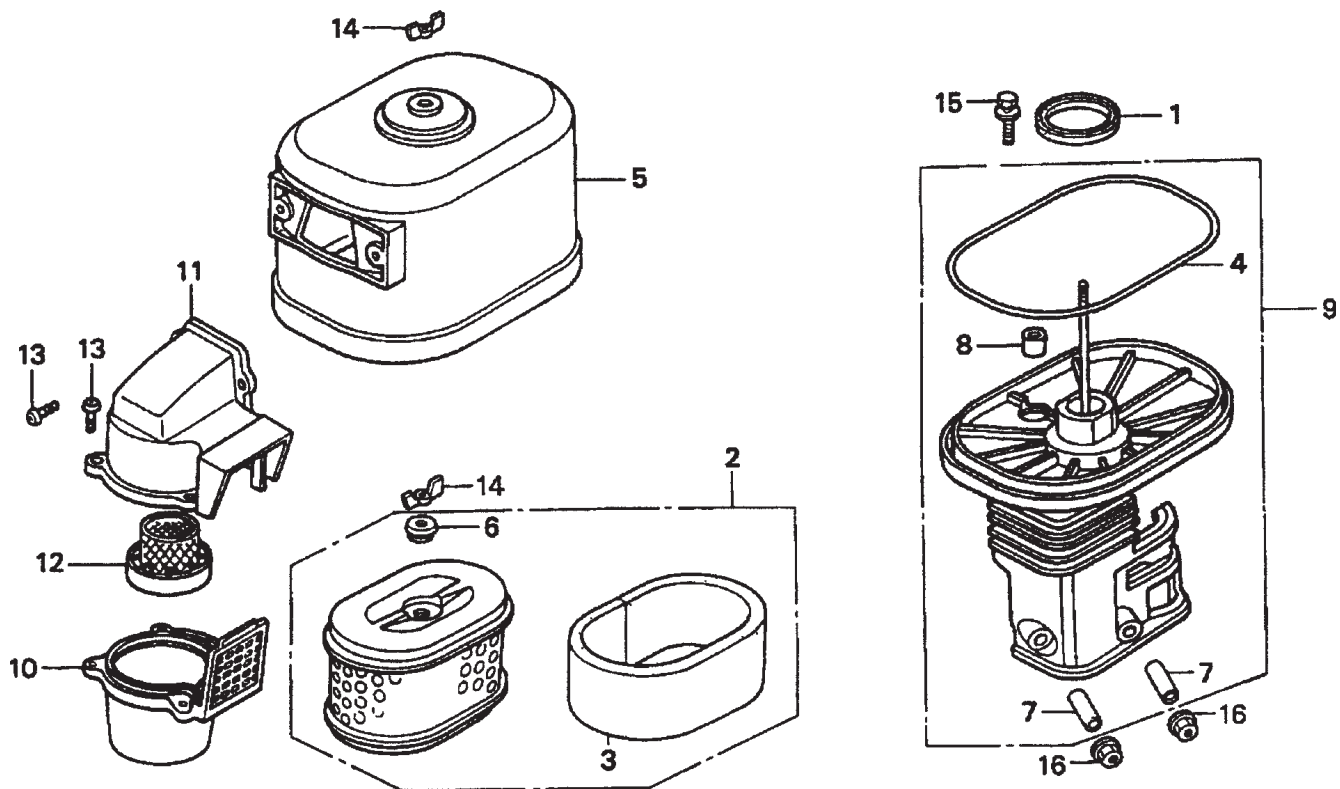



# HONDA GX390K1QWT2 ENGINE — AIR CLEANER ASSY.

## AIR CLEANER ASSY.

<u>NO.</u>	<u>PART NO.</u>	<u>PART NAME</u>	<u>QTY.</u>	<u>REMARKS</u>
1	16271ZE2000	GASKET, ELBOW	1	
2	17210ZE3505	ELEMENT, AIR CLEANER .....	1	INCLUDES ITEMS W/*
3*	17218ZE3505	FILTER, OUTER	1	
4#	17219HA2405	SEAL, AIR CLEANER COVER	1	
5	17230ZE3841	COVER, AIR CLEANER (CYCLONE)	1	
6*	17232891000	GROMMET, AIR CLEANER	1	
7#	17238ZE2310	COLLAR, AIR CLEANER	2	
8#	17239ZE3840	COLLAR B, AIR CLEANER	1	
9	17410ZE3840	ELBOW, AIR CLEANER .....	1	INCLUDES ITEMS W/#
10	17470ZE3841	CASE, PRE AIR CLEANER	1	
11	17475ZE3841	CAP, PRE AIR CLEANER	1	
12	17476ZE3841	GUIDE, PRE AIR CLEANER	1	
13	90142MB0000	SCREW, PAN 5X16.5	5	
14	90325044000	WINGNUT, TOOL BOX SETTING	2	
15	90009ZE2003	BOLT- WASHER 6X22	1	
16	0405006000	NUT, FLANGE 6MM	2	

# HONDA GX390K1QWT2 ENGINE — CAMSHAFT ASSY.

CAMSHAFT ASSY.

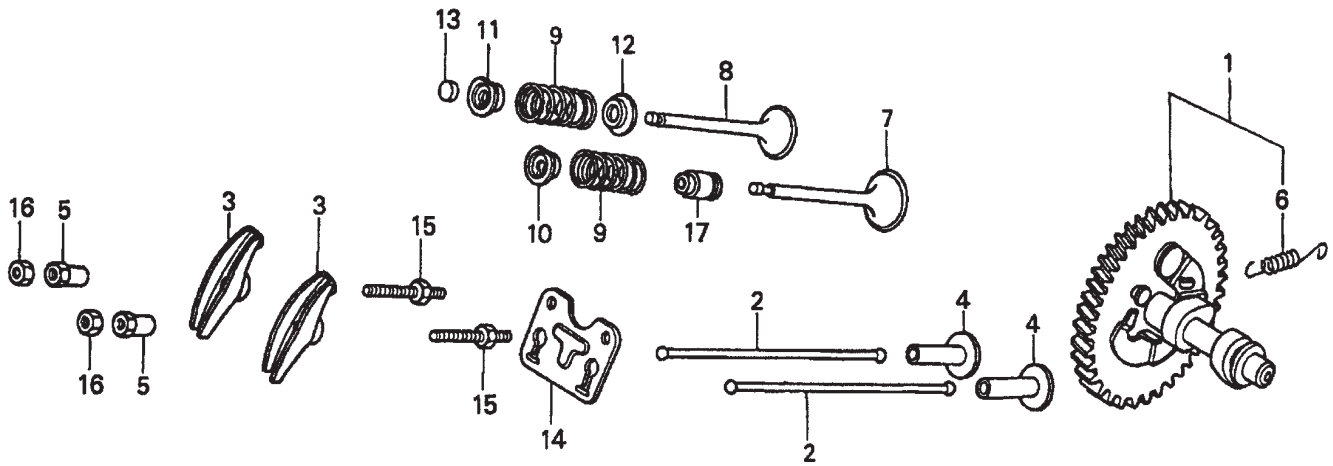

# HONDA GX390K1QWT2 ENGINE — CAMSHAFT ASSY.

## CAMSHAFT ASSY.

<u>NO.</u>	<u>PART NO.</u>	<u>PART NAME</u>	<u>QTY.</u>	<u>REMARKS</u>
1	14100ZF6W01	CAMSHAFT ASSEMBLY .....	1	INCLUDES ITEM W/*
2	14410ZE3013	ROD, PUSH	2	
3	14431ZE2010	ARM, VALVE ROCKER	2	
4	14441ZE2000	LIFTER, VALVE	2	
5	14451ZE1013	PIVOT, ROCKER ARM	2	
6*	14568ZE1000	SPRING, WEIGHT RETURN	1	
7	14711ZE3000	VALVE, INTAKE	1	
8	14721ZE3000	VALVE, EXHAUST	1	
9	14751ZE2003	SPRING, VALVE	2	
10	14771ZE2000	RETAINER, INTAKE VALVE SPRING	1	
11	14773ZE2000	RETAINER, EXHAUST VALVE SPRING	1	
12	14775ZE2010	SEAT, VALVE SPRING	1	
13	14781ZE2000	ROTATOR, VALVE	1	
14	14791ZE2010	PLATE, PUSH ROD GUIDE	1	
15	90012ZE0010	BOLT, PIVOT 8MM	2	
16	90206ZE1000	NUT, PIVOT ADJ.	2	
17	12209ZE8003	SEAL, VALVE STEM	1	

# HONDA GX390K1QWT2 ENGINE — CARBURETOR ASSY.

CARBURETOR ASSY.

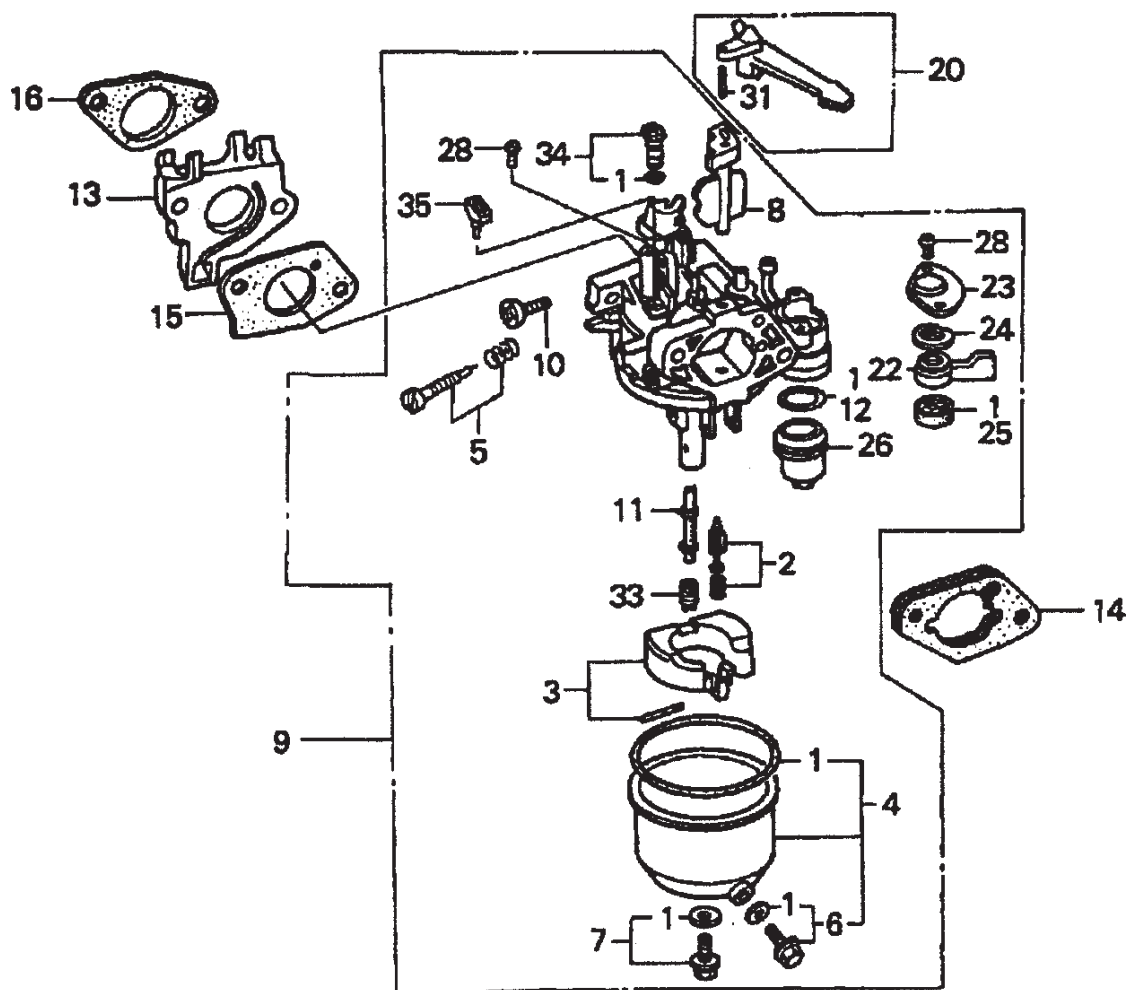

# HONDA GX390K1QWT2 ENGINE — CARBURETOR ASSY.

## CARBURETOR ASSY.

<u>NO.</u>	<u>PART NO.</u>	<u>PART NAME</u>	<u>QTY.</u>	<u>REMARKS</u>
1*#+	16010ZE2812	GASKET SET	1	
2*	16011ZA0931	VALVE SET, FLOAT	1	
3*	16013ZA0931	FLOAT SET	1	
4*	16015ZE8005	CHAMBER SET, FLOAT .....	1	INCLUDES ITEMS W/+
5*	16016ZH7W01	SCREW SET	1	
6*+	16024ZE1811	SCREW SET, DRAIN .....	1	INCLUDES ITEM W/#
7*	16028ZE0005	SCREW SET B .....	1	INCLUDES ITEM W/#
8*	16044ZE3W20	CHOKE SET	1	
9	16100ZF6V21	CARBURETOR ASSY. (BE85C B) .....	1	INCLUDES ITEMS W/*
10*	16124ZE0005	SCREW, THROTTLE STOP	1	
11*	16166ZF6W10	NOZZLE, MAIN	1	
12*	16173001004	GASKET, FUEL STRAINER CUP	1	
13	16211ZF6000	INSULATOR, CARBURETOR	1	
14	16220ZA0702	SPACER, CARBURETOR	1	
15	16221ZF6800	GASKET, CARBURETOR	1	
16	16223ZE3W00	GASKET, INSULATOR	1	
20	16610ZE1000	LEVER, CHOKE (STD) .....	1	INCLUDES ITEM W/\$
22*	16953ZE1812	LEVER, VALVE	1	
23*	16954ZE1812	PLATE, LEVER SETTING	1	
24*	16956ZE1811	SPRING, VALVE LEVER	1	
25*	16957ZE1812	GASKET, VALVE	1	
26*	16967ZE0811	CUP, FUEL STRAINER	1	
28*	93500030060H	SCREW, PAN (3X6)	2	
31\$	9430520122	PIN, SPRING (2X12)	1	
33*	99101ZH80950	JET, MAIN (#95) (OPTIONAL)	1	
33	99101ZH80980	JET, MAIN (#98) (OPTIONAL)	1	
33*	99101ZH81000	JET, MAIN (#100)	1	
34*	99204ZA00450	JET SET, PILOT (#45) .....	1	INCLUDES ITEM W/#
35*	16172ZE3W10	COLLAR, SET	1	

# HONDA GX390K1QWT2 ENGINE — CONTROL ASSY.

CONTROL ASSY.

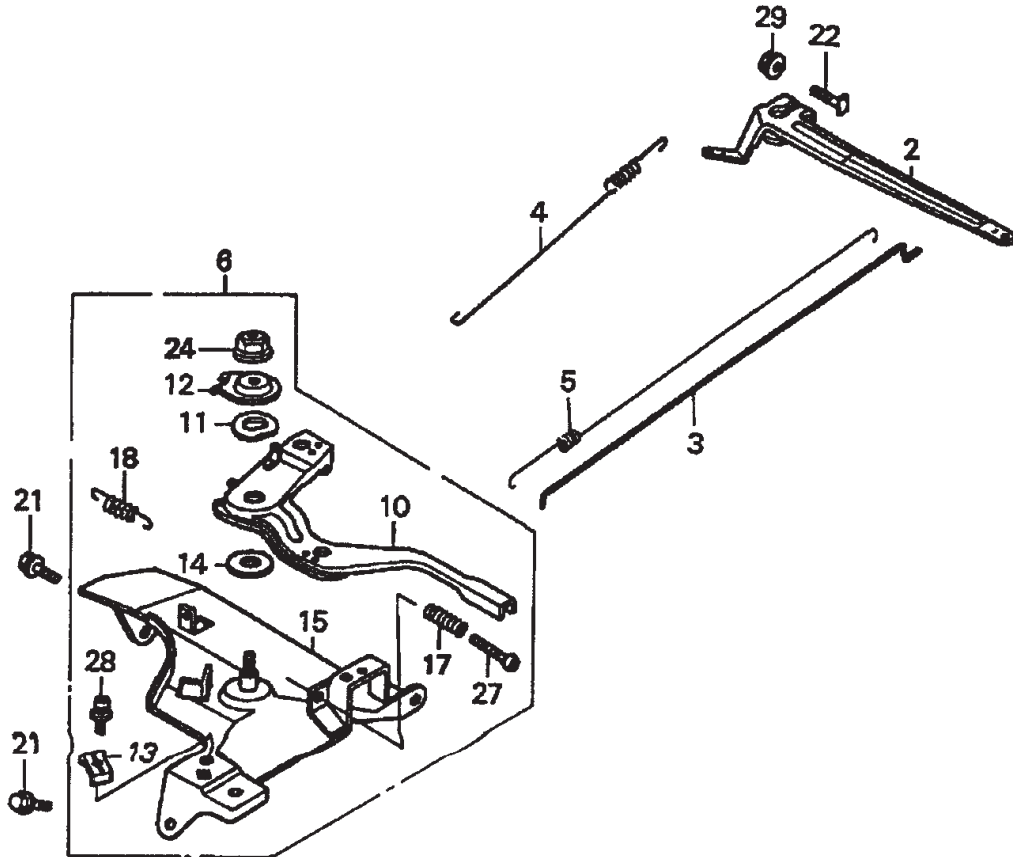

# HONDA GX390K1QWT2 ENGINE — CONTROL ASSY.

## CONTROL ASSY.

<u>NO.</u>	<u>PART NO.</u>	<u>PART NAME</u>	<u>QTY.</u>	<u>REMARKS</u>
2	16551ZE3000	ARM, GOVERNOR	1	
3	16555ZE3000	ROD, GOVERNOR	1	
4	16561ZE3000	SPRING, GOVERNOR	1	
5	16562ZE3000	SPRING, THROTTLE RETURN	1	
6	16570ZE3W20	CONTROL ASSY. (REMOTE) .....	1	INCLUDES ITEMS W/*
10*	16571ZE3W00	LEVER, CONTROL	1	
11*	16574ZE1000	SPRING, LEVER	1	
12*	16575ZE2W00	WASHER, CONTROL LEVER	1	
13*	16576891000	HOLDER, CABLE	1	
14*	16578ZE1000	SPACER, CONTROL LEVER	1	
15*	16581ZE3W00	BASE, CONTROL	1	
17*	16584883300	SPRING, CONTROL ADJUSTING	1	
18*	16592883310	SPRING, CABLE RETURN	1	
21	90013883000	BOLT, FLANGE (6X12) (CT200)	2	
22	90015ZE5010	BOLT, GOVERNOR ARM	1	
24*	90114SA0000	NUT, SELF-LOCK (6MM)	1	
27*	93500050320A	SCREW, PAN (5X32)	1	
28*	93500050160A	SCREW, PAN (5X16)	1	
29	9405006000	NUT, FLANGE (6MM)	1	

# HONDA GX390K1QWT2 ENGINE — CRANKCASE ASSY.

## CRANKCASE COVER ASSY.

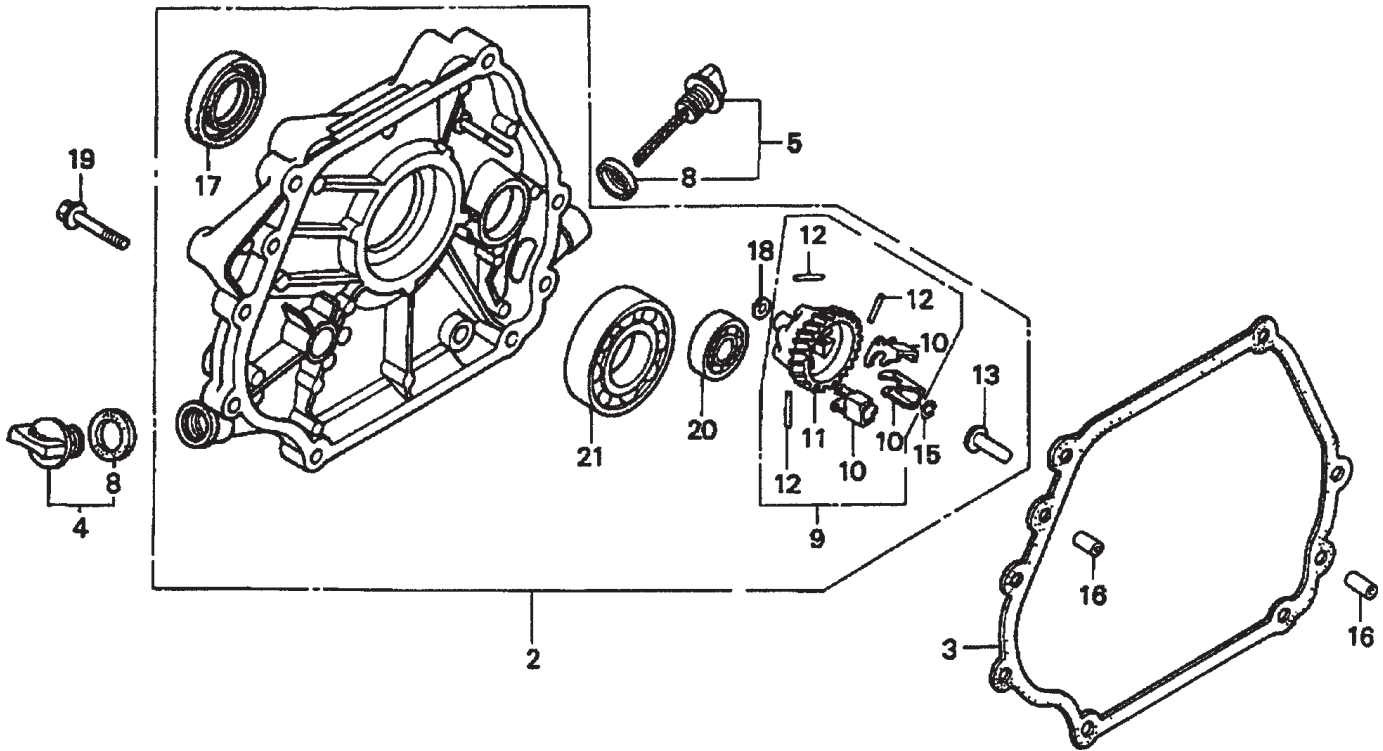



# HONDA GX390K1QWT2 ENGINE — CRANKCASE ASSY.

## CRANKCASE COVER ASSY.

<u>NO.</u>	<u>PART NO.</u>	<u>PART NAME</u>	<u>QTY.</u>	<u>REMARKS</u>
2	11300ZE3602	COVER ASSY., CRANKCASE (Q-TYPE).....	1	INCLUDES ITEMS W/*
3	11381ZE3801	GASKET, CASE COVER	1	
4	15600ZG4003	CAP ASSY., OIL FILLER .....	1	INCLUDES ITEM W/#
5	15600735003	CAP ASSY., OIL FILLER .....	1	INCLUDES ITEM W/#
8#	15625ZE1003	GASKET, OIL FILLER CAP	2	
9	16510ZE3000	GOVERNOR ASSY.....	1	INCLUDES ITEMS W/+
10*+	16511ZE8000	WEIGHT, GOVERNOR	3	
11*+	16512ZE3000	HOLDER, GOVERNOR WEIGHT	1	
12*+	16513ZE2000	PIN, GOVERNOR WEIGHT	3	
13*	16531ZE2000	SLIDER, GOVERNOR	1	
13*	16531Z0A000	SLIDER, GOVERNOR	1	
15*	90602ZE1000	CLIP, GOVERNOR HOLDER	1	
16	90701HC4000	PIN, DOWEL (8X12)	2	
17*	91201ZE3004	OIL SEAL (35X52X8)	1	
18*	9410106800	WASHER, PLAIN (6MM)	1	
19	957010804000	BOLT, FLANGE (8X40)	7	
20*	961006202000	BEARING, RADIAL BALL (6202)	1	
21*	961006207000	BEARING, RADIAL BALL (6207)	1	

# HONDA GX390K1QWT2 ENGINE — CRANKSHAFT ASSY.

CRANKSHAFT ASSY.

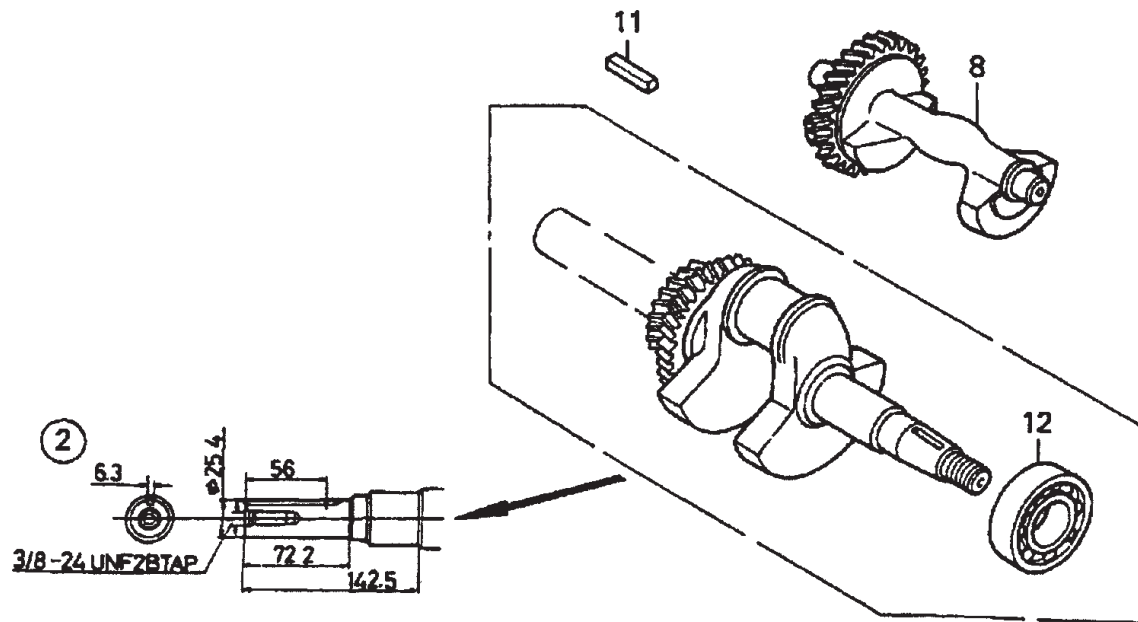

# HONDA GX390K1QWT2 ENGINE — CRANKSHAFT ASSY.

## CRANKSHAFT ASSY.

<u>NO.</u>	<u>PART NO.</u>	<u>PART NAME</u>	<u>QTY.</u>	<u>REMARKS</u>
2	13310ZF6W10	CRANKSHAFT (Q-TYPE).....	1	INCLUDES ITEM W/*
8	13351ZE3010	WEIGHT, BALANCER	1	
11	90745ZE2600	KEY(6.3X6.3X43)	1	
12*	91001ZF6003	BEARING, RADIAL BALL (6207S)	1	

# HONDA GX390K1QWT2 ENGINE — CYLINDER BARREL ASSY.

CYLINDER BARREL ASSY.

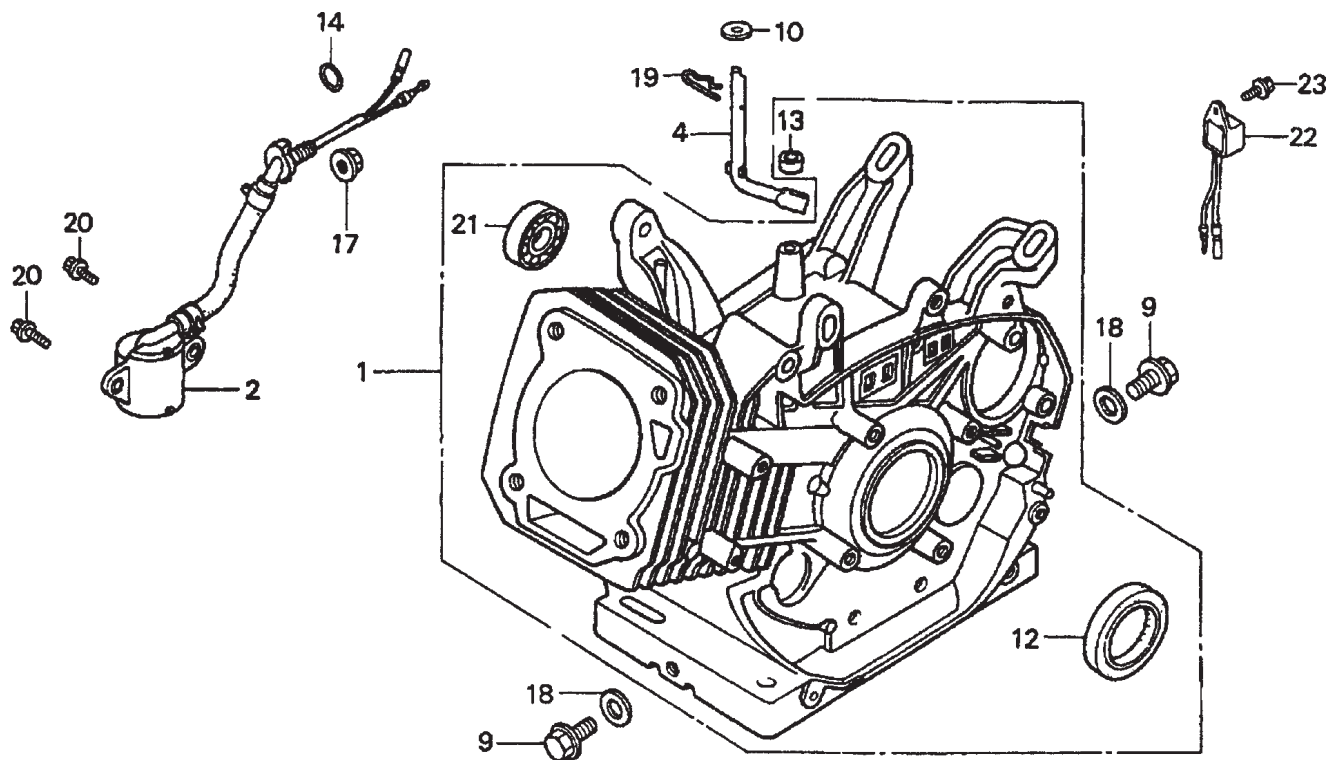

# HONDA GX390K1QWT2 ENGINE — CYLINDER BARREL ASSY.

## CYLINDER BARREL ASSY.

<u>NO.</u>	<u>PART NO.</u>	<u>PART NAME</u>	<u>QTY.</u>	<u>REMARKS</u>
1	12000ZF6W13	CYLINDER ASSY. (ALERT) .....	1	INCLUDES ITEMS W/*
2	15510ZE2043	SWITCH ASSY., OIL LEVEL	1	
4	16541ZE3010	SHAFT, GOVERNOR ARM	1	
9	90131896650	BOLT, DRAIN PLUG	2	
10	90446KE1000	WASHER (8.2X17X0.8)	1	
12*	91201ZE3004	OIL SEAL (35X52X8)	1	
13*	91201ZE9003	OIL SEAL (8X14X5)	1	
14	91353671003	O-RING (13.5X1.5) (ARAI)	1	
17	9405010000	NUT, FLANGE (10MM)	1	
18	9410912000	WASHER, DRAIN PLUG (12MM)	2	
19	9425110000	PIN, LOCK (10MM)	1	
20	957010601200	BOLT, FLANGE (6X12)	2	
21*	961006202000	BEARING, RADIAL BALL (6202)	1	
22	34150ZH7003	ALERT UNIT, OIL	1	
23	90013883000	BOLT, FLANGE (6X12) (CT200)	1	

# HONDA GX390K1QWT2 ENGINE — CYLINDER HEAD ASSY.

CYLINDER HEAD ASSY.

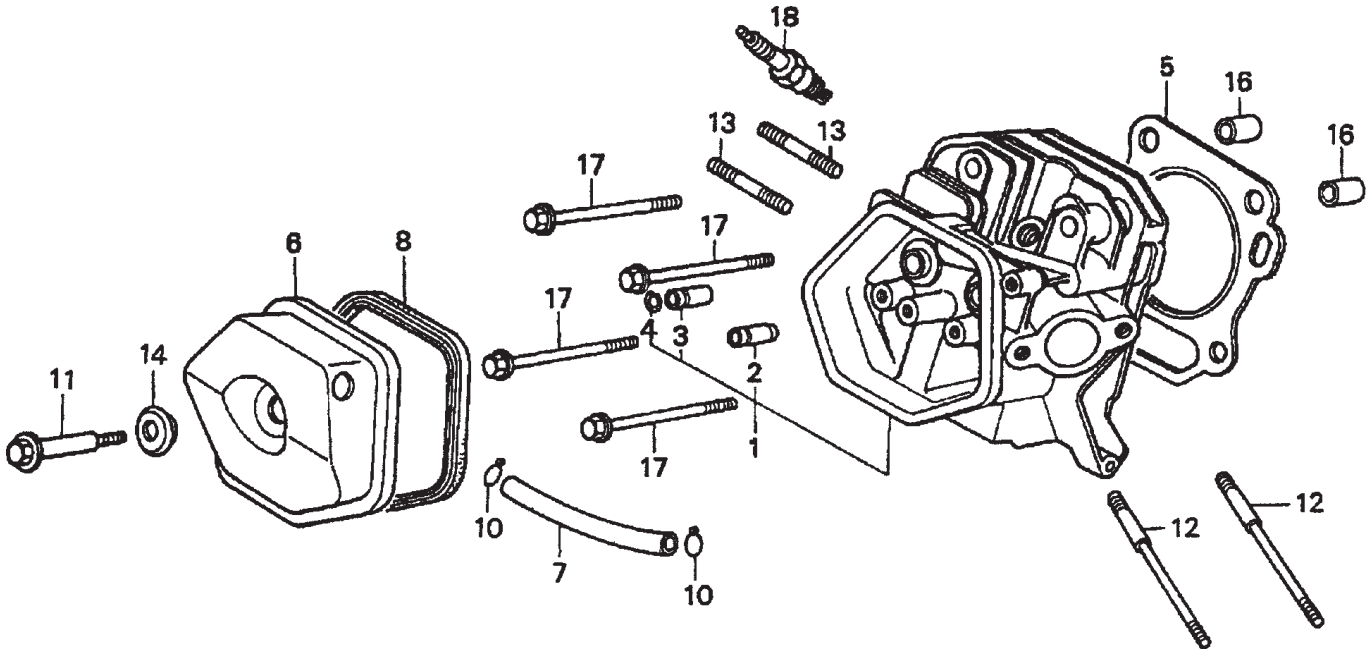

# HONDA GX390K1QWT2 ENGINE — CYLINDER HEAD ASSY.

## CYLINDER HEAD ASSY.

<u>NO.</u>	<u>PART NO.</u>	<u>PART NAME</u>	<u>QTY.</u>	<u>REMARKS</u>
1	12200ZF6W01	CYLINDER HEAD .....	1 .....	INCLUDES ITEMS W/*
2*	12204ZE2306	GUIDE, VALVE (OS) (OPTIONAL)	1	
3*	12205ZE2305	GUIDE, EX. VALVE (OS) (OPTIONAL)	1	
4*	12216ZE2300	CLIP, VALVE GUIDE	1	
5	12251ZF6W00	GASKET, CYLINDER HEAD	1	
6	12310ZE3791	COVER, HEAD	1	
7	12315ZE3840	TUBE, BREATHER	1	
8	12391ZE2020	GASKET, CYLINDER HEAD COVER	1	
10	17316611000	CLIP, BREATHER TUBE	2	
11	90014ZE2000	BOLT, HEAD COVER	1	
12	90042ZE8000	BOLT, STUD (8X131.5)	2	
13	92900080320E	BOLT 2, STUD (8X32)	2	
14	90441ZE2010	WASHER, HEAD COVER	1	
16	9430112200	PIN A, DOWEL (12X20)	2	
17	957011008000	BOLT, FLANGE (10X80)	4	
18	9807955846	SPARK PLUG (BPR5ES) (NGK) (OPT.)	1	
18	9807956846	SPARK PLUG (BPR6ES) (NGK)	1	

# HONDA GX390K1QWT2 ENGINE — FAN COVER ASSY.

FAN COVER ASSY.

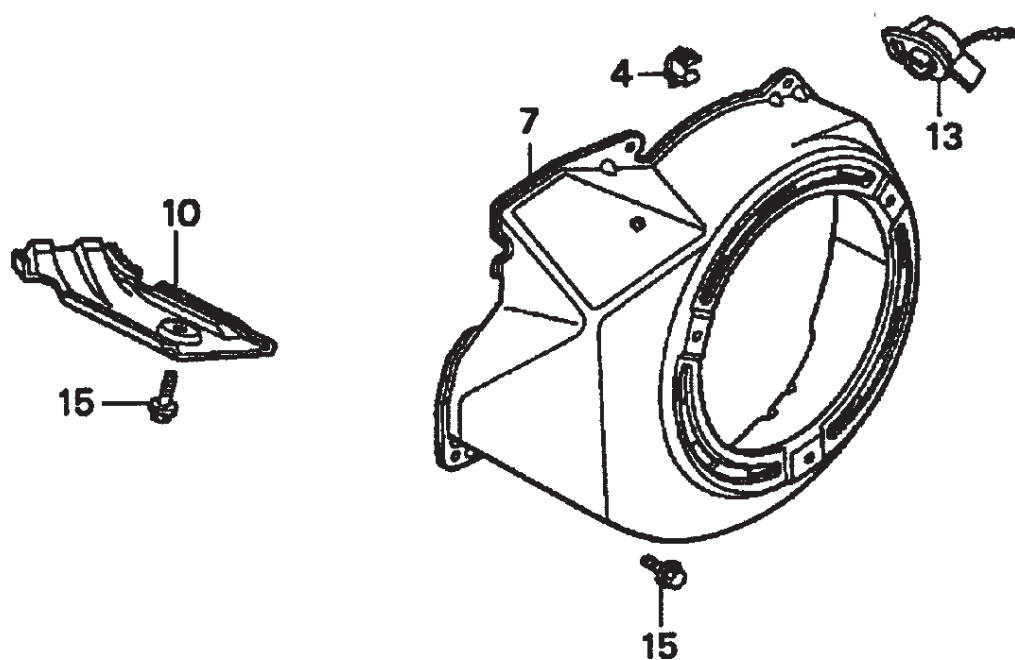



# HONDA GX390K1QWT2 ENGINE — FAN COVER ASSY.

FAN COVER ASSY.

<u>NO.</u>	<u>PART NO.</u>	<u>PART NAME</u>	<u>QTY.</u>	<u>REMARKS</u>
4	16731ZE2003	CLIP, TUBE	1	
7	19610ZE3010ZB	COVER, FAN *NH1* (BLACK)	1	
10	19631ZE3W00	SHROUD	1	
13	36100ZH7003	SWITCH ASSY., ENGINE STOP	1	
15	90013883000	BOLT, FLANGE (6X12) (CT200)	6	

# HONDA GX390K1QWT2 ENGINE — FLYWHEEL ASSY.

FLYWHEEL ASSY.

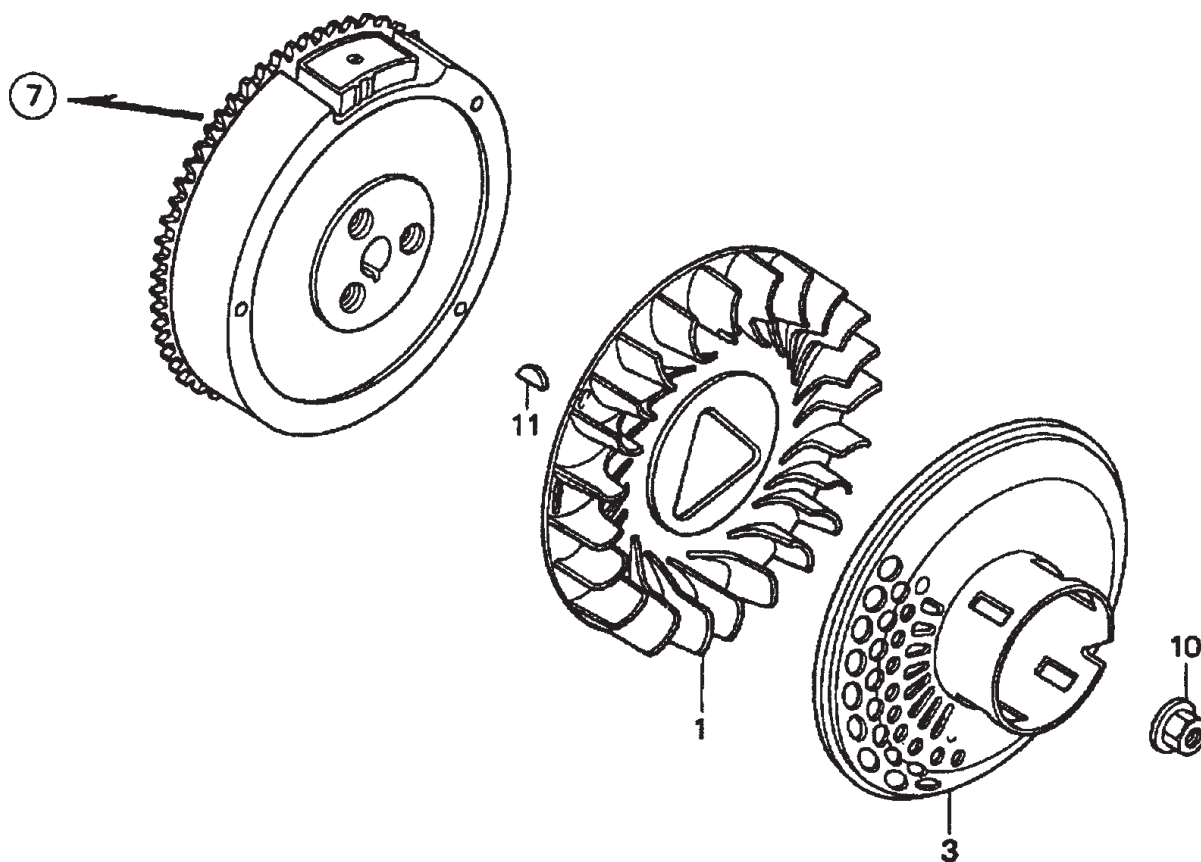

## HONDA GX390K1QWT2 ENGINE — FLYWHEEL ASSY.

FLYWHEEL ASSY.

<u>NO.</u>	<u>PART NO.</u>	<u>PART NAME</u>	<u>QTY.</u>	<u>REMARKS</u>
1	19511ZE3000	FAN, COOLING	1	
3	28450ZE3W11	PULLEY, STARTER (SCREEN GRID)	1	
7	31100ZE3701	FLYWHEEL	1	
10	90201ZE3V00	NUT, SPECIAL (16MM) (1)	1	
11	90741ZE2000	KEY, SPECIAL WOODRUFF (25X18)	1	

# HONDA GX390K1QWT2 ENGINE — FUEL TANK ASSY.

FUEL TANK ASSY.

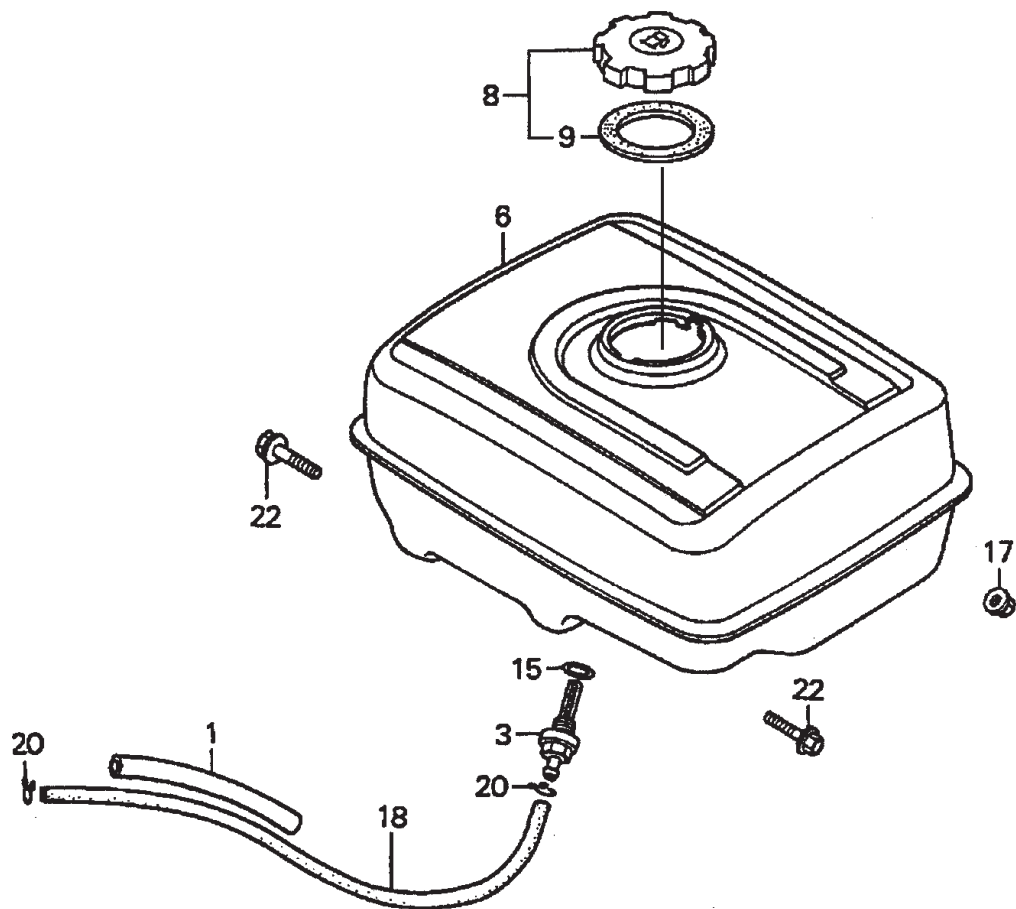

# HONDA GX390K1QWT2 ENGINE — FUEL TANK ASSY.

## FUEL TANK ASSY.

<u>NO.</u>	<u>PART NO.</u>	<u>PART NAME</u>	<u>QTY.</u>	<u>REMARKS</u>
1	16854ZH8000	RUBBER, SUPPORTER (107MM)	1	
3	16955ZE1000	JOINT, FUEL TANK	1	
6	17510ZE3010ZB	TANK, FUEL *NH1* (BLACK)	1	
8	17620ZH7023	CAP, FUEL FILLER .....	1	INCLUDES ITEM W/*
9*	17631ZH7003	GASKET, FUEL FILLER CAP	1	
15	91353671003	O-RING (13.5X1.5) (ARAI)	1	
17	9405008000	NUT, FLANGE (8MM)	2	
18	950014500360M	BULK HOSE, FUEL (4.5X3000) (4.5X235)	1	
20	9500202080	CLIP, TUBE (B8)	2	
22	957010802500	BOLT, FLANGE (8X25)	2	

# HONDA GX390K1QWT2 ENGINE — IGNITION COIL ASSY.

IGNITION COIL ASSY.

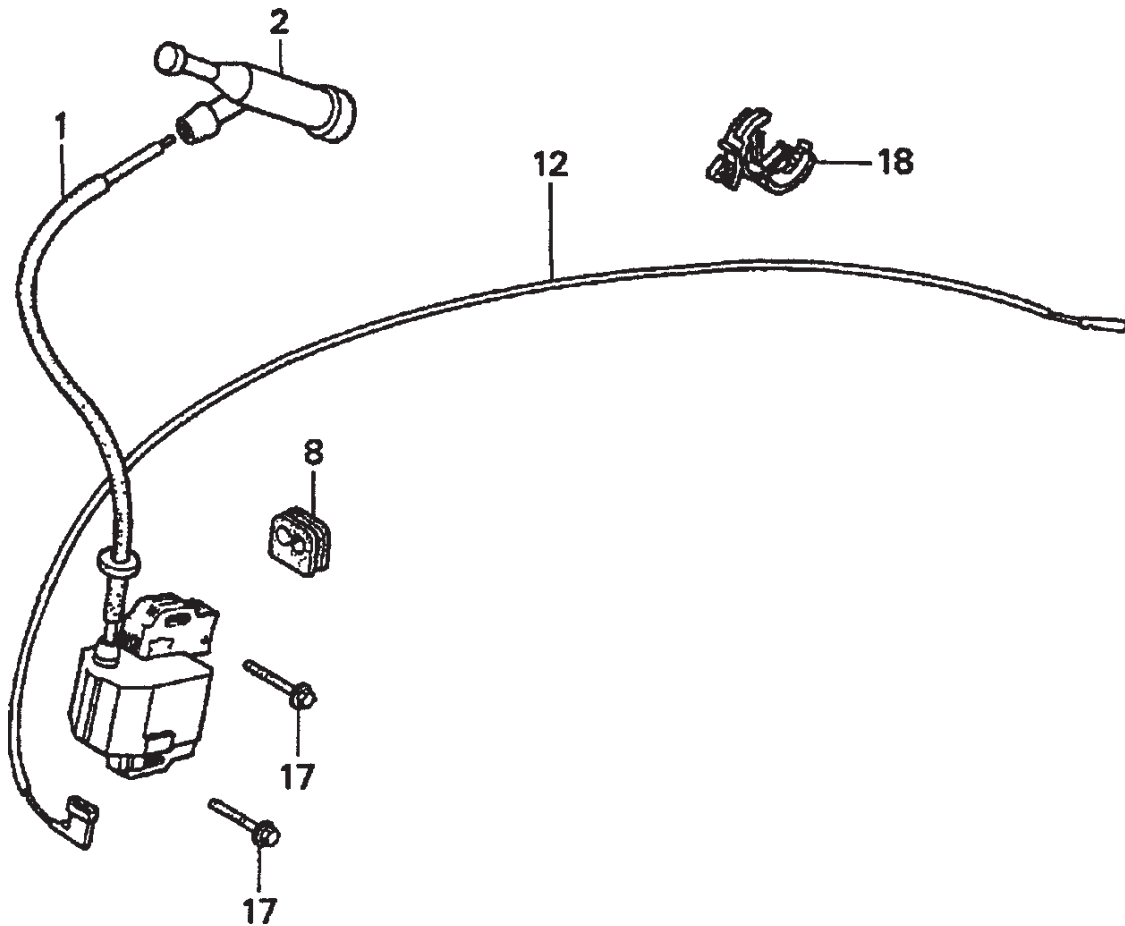

# HONDA GX390K1QWT2 ENGINE — IGNITION COIL ASSY.

## IGNITION COIL ASSY.

<u>NO.</u>	<u>PART NO.</u>	<u>PART NAME</u>	<u>QTY.</u>	<u>REMARKS</u>
1	30500ZF6W01	COIL ASSY., IGNITION	1	
2	30700ZE1013	CAP ASSY., NOISE SUPPRESSOR	1	
8	31512ZE2000	GROMMET, WIRE	1	
12	36101ZE2701	WIRE, STOP SWITCH (430MM)	1	
17	90015883000	BOLT, FLANGE (6X28)	2	
18	90684ZA0601	CLIP, WIRE HARNESS	1	

# HONDA GX390K1QWT2 ENGINE — MUFFLER ASSY.

MUFFLER (1) ASSY.

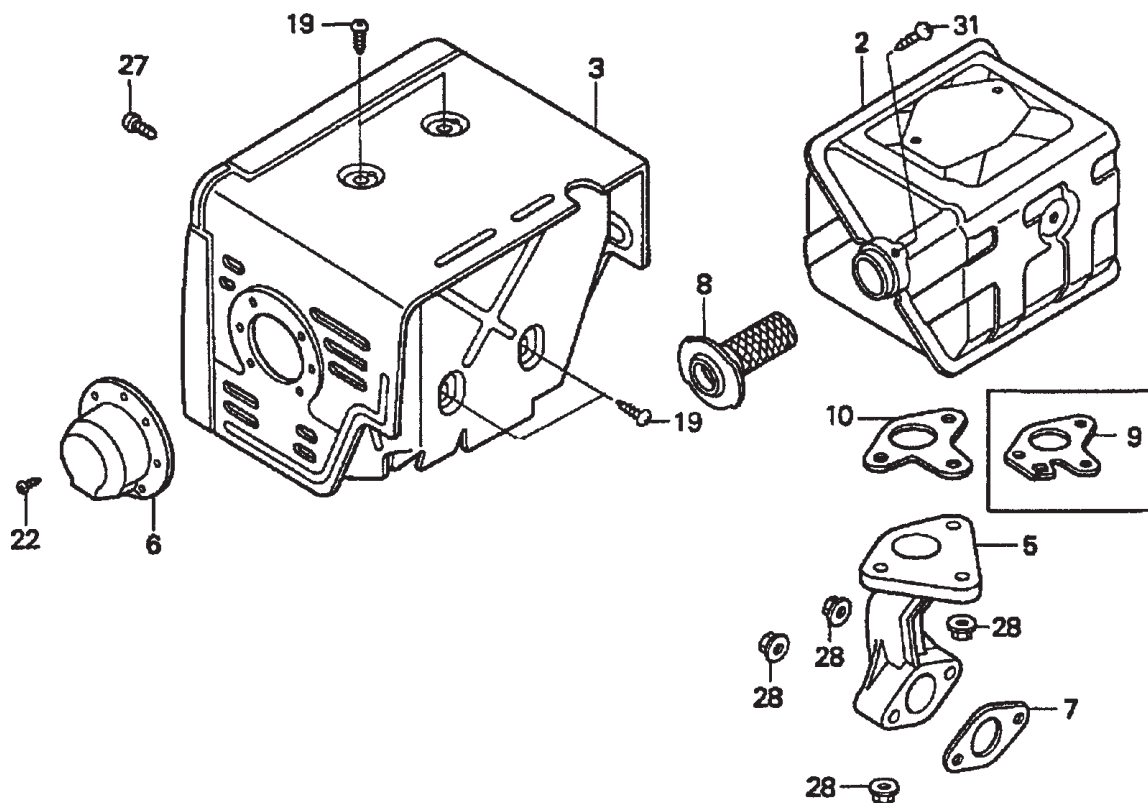



## HONDA GX390K1QWT2 ENGINE — MEFFLER ASSY.

MUFFLER (1) ASSY.

<u>NO.</u>	<u>PART NO.</u>	<u>PART NAME</u>	<u>QTY.</u>	<u>REMARKS</u>
2	18310ZE2W61	MUFFLER	1	
3	18320ZE2W61	PROTECTOR, MUFFLER	1	
5	18330ZE2W00	PIPE, EX.	1	
6	18331ZE3810	CAP, MUFFLER	1	
7	18333ZF6W01	GASKET, EX. PIPE	1	
8	18355ZE2W00	ARRESTER, SPARK (OPTIONAL)	1	
9	18381ZE2W10	GASKET, MUFFLER (ARRESTER) (OPTIONAL)	1	
10	18381ZE2800	GASKET, MUFFLER	1	
19	90050ZE1000	SCREW, TAPPING (5X8)	4	
22	90055ZE1000	SCREW, TAPPING (4X6)	3	
27	90006ZE2000	SCREW, TAPPING (6X10)	1	
28	9405008000	NUT, FLANGE (8MM)	5	
31	90055ZE1000	SCREW, TAPPING (4X6)	1	

# HONDA GX390K1QWT2 ENGINE — PISTON ASSY.

PISTON ASSY.

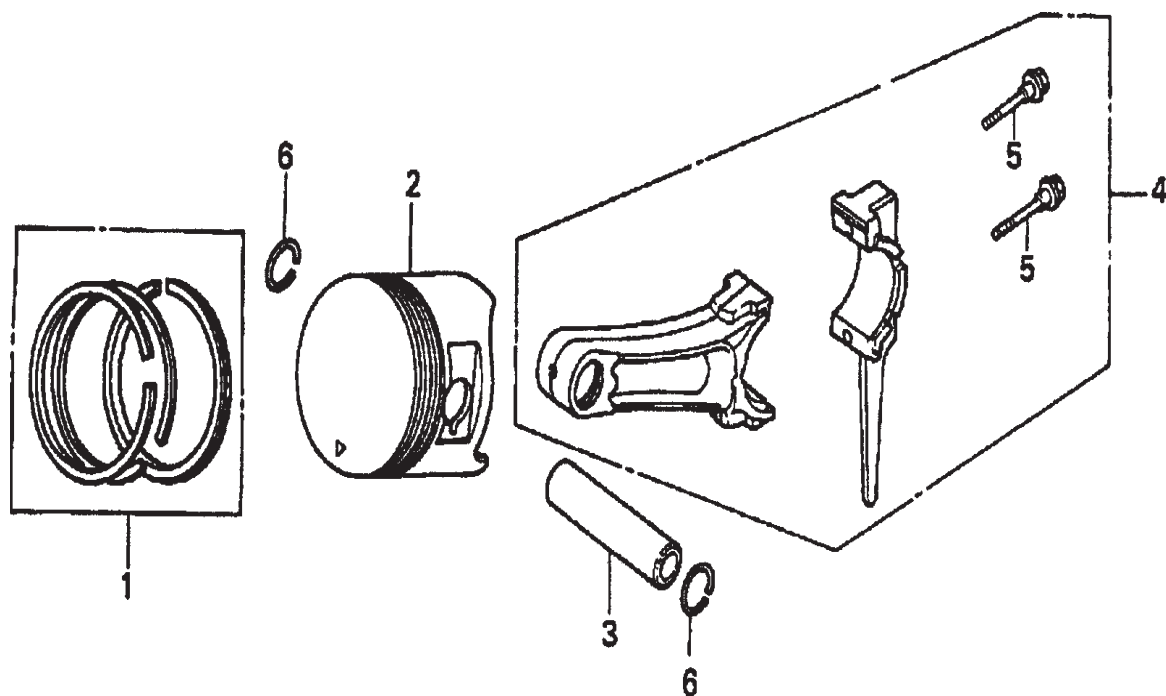

# HONDA GX390K1QWT2 ENGINE — PISTON ASSY.

PISTON ASSY.

<u>NO.</u>	<u>PART NO.</u>	<u>PART NAME</u>	<u>QTY.</u>	<u>REMARKS</u>
1	13010ZF6003	RING SET, PISTON (STD)	1	
1	13011ZF6003	RING SET, PISTON (OS 0.25) (OPTIONAL)	1	
1	13012ZF6003	RING SET, PISTON (OS 0.50) (OPTIONAL)	1	
1	13012ZF6005	RING SET, PISTON (OS 0.50) (OPTIONAL)	1	
1	13013ZF6003	RING SET, PISTON (0.75) (NIPPON)	1	
2	13101ZF6W00	PISTON (STD)	1	
2	13102ZF6W00	PISTON (OS 0.25) (OPTIONAL)	1	
2	13103ZF6W00	PISTON (OS 0.50) (OPTIONAL)	1	
2	13104ZF6W00	PISTON (0.75) (OPTIONAL)	1	
3	13111ZF6W00	PIN, PISTON	1	
4	13200ZE3010	ROD ASSY., CONNECTING (STD) .....	1	INCLUDES ITEM W/*
4	13200ZE3315	ROD ASSY., CONNECTING(US 0.25) (OPT.) .....	1	INCLUDES ITEM W/*
5*	90001ZE8000	BOLT, CONNECTING ROD	2	
6	90601ZE3000	CLIP, PISTON PIN (20MM)	2	

# HONDA GX390K1QWT2 ENGINE — RECOIL STATER ASSY.

RECOIL STARTER ASSY.

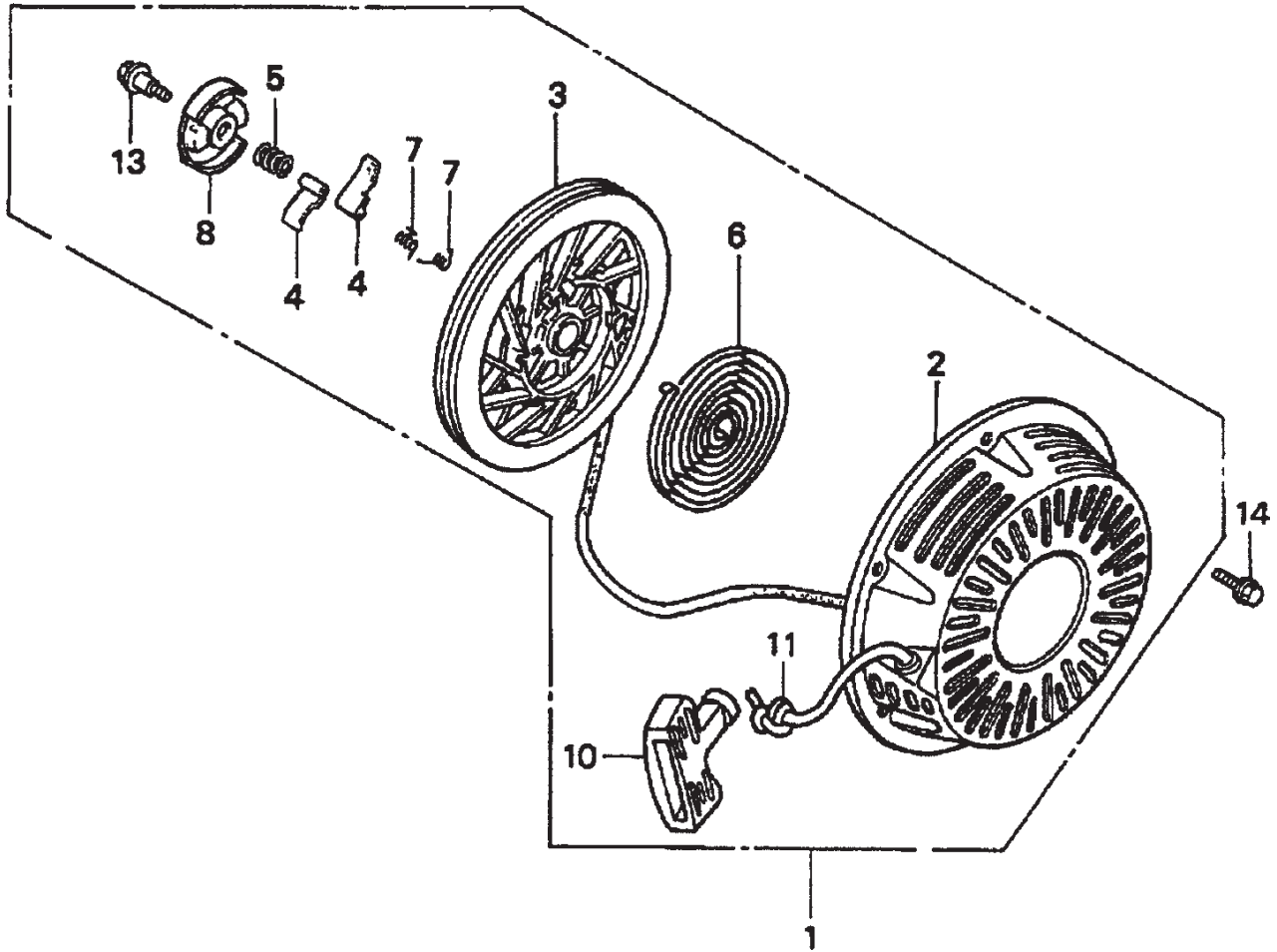

# HONDA GX390K1QWT2 ENGINE — RECOIL STATER ASSY.

## RECOIL STARTER ASSY.

<u>NO.</u>	<u>PART NO.</u>	<u>PART NAME</u>	<u>QTY.</u>	<u>REMARKS</u>
1	28400ZE3W01ZB	STARTER ASSY., RECOIL *NH1* (BLACK) .....	1 .....	INCLUDES ITEMS W/*
2*	28410ZE3W01ZB	CASE, RECOIL STARTER *NH1* (BLACK)	1	
3*	28421ZE3W01	PULLEY, RECOIL STARTER	1	
4*	28422ZE2W01	RATCHET, STARTER	2	
5*	28441ZE2W01	SPRING, FRICTION	1	
6*	28442ZE2W01	SPRING, STARTER RETURN	1	
7*	28443ZE2W01	SPRING, RATCHET	2	
8*	28444ZE2W01	RETAINER, SPRING	1	
10*	28461ZE2W02	GRIP, STARTER	1	
11*	28462ZV7003	ROPE, RECOIL STARTER	1	
13*	90004ZE2W01	SCREW, CENTER	1	
14	90008ZE2003	BOLT, FLANGE (6X10)	3	

# HONDA GX390K1QWT2 ENGINE — LABELS ASSY.

LABELS ASSY.

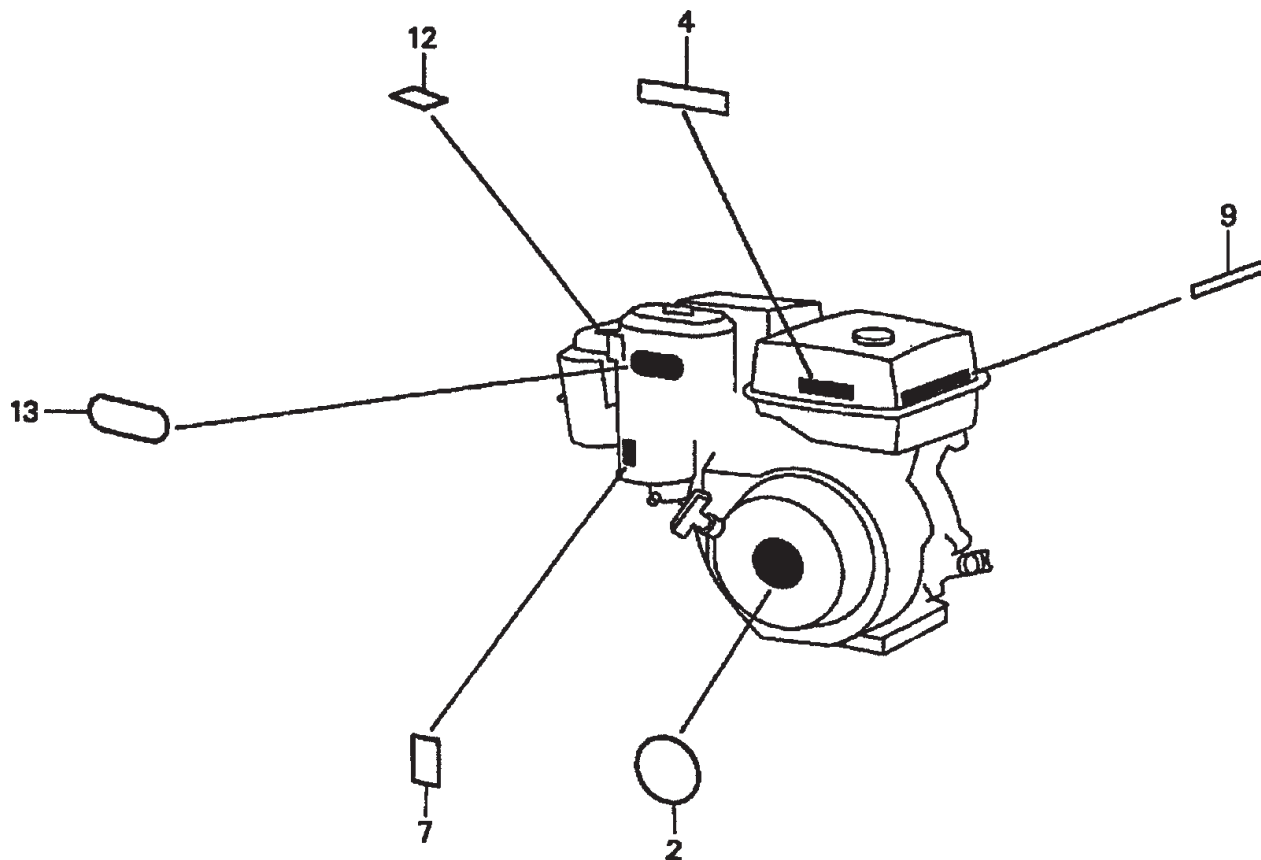

## HONDA GX390K1QWT2 ENGINE — LABELS ASSY.

### LABELS ASSY.

<u>NO.</u>	<u>PART NO.</u>	<u>PART NAME</u>	<u>QTY.</u>	<u>REMARKS</u>
2	87521ZF6W01	EMBLEM	1	
4	87522ZH9000	LABEL, CAUTION	1	
7	87528ZE2810	MARK, CHOKE (EXTERNAL)	1	
9	87532ZH8810	MARK, OIL ALERT (E)	1	
12	87534ZE1841	LABEL, AIR CLEANER CAUTION	1	
13	87535ZE1840	MARK, AIR CLEANER SALES POINT	1	

# HONDA GX620TXF2 ENGINE — AIR CLEANER ASSY.

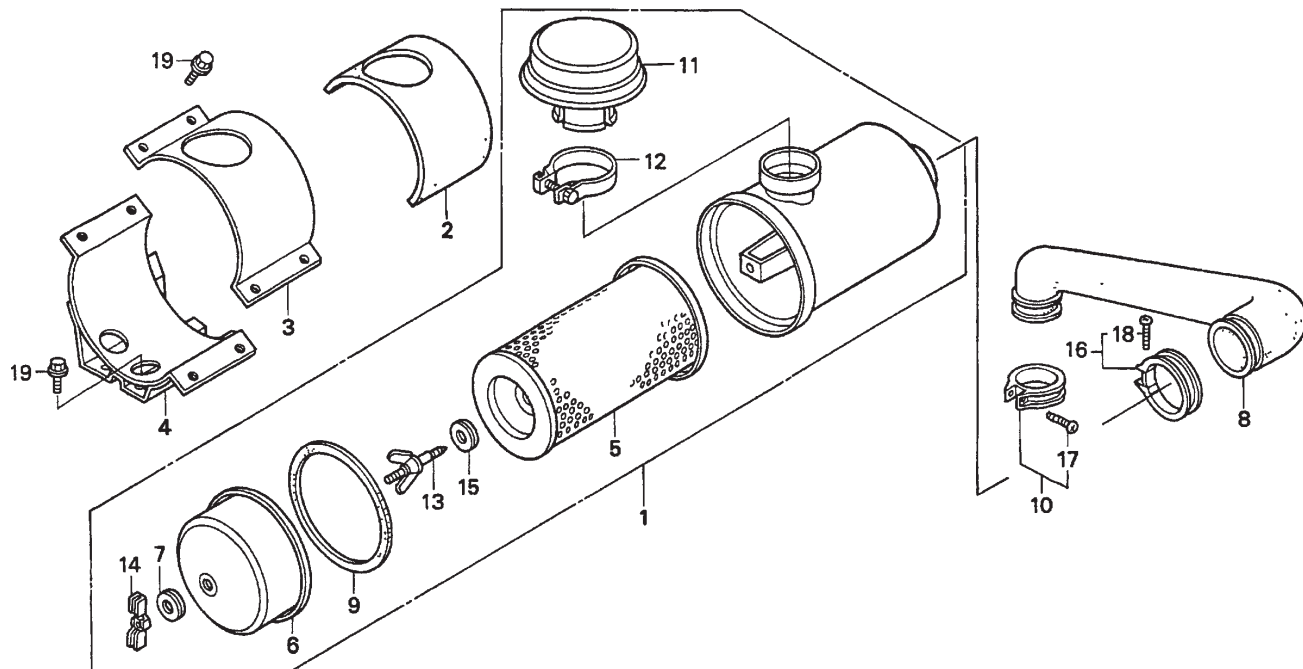



# HONDA GX620TXF2 ENGINE — AIR CLEANER ASSY.

## AIR CLEANER ASSY.

<u>NO</u>	<u>PART NO</u>	<u>PART NAME</u>	<u>QTY.</u>	<u>REMARKS</u>
1	17200ZJ0U70	AIR CLEANER ASSY. ....	1	INCLUDES ITEMS W/*
2	17207ZJ0U70	RUBBER, AIR CLEANER HOLDER	1	
3	17208ZJ0U70	HOLDER, AIR CLEANER, UPPER	1	
4	17209ZJ0U70	HOLDER, AIR CLEANER, LOWER	1	
5*	17210759013	ELEMENT. AIR CLEANER	1	
6*	17230759003	COVER, AIR CLEANER	1	
7*	17232891000	GROMMET, AIR CLEANER	1	
8	17251ZJ0U70	TUBE, AIR CLEANER	1	
9*	17253759003	SEAL, AIR CLEANER	1	
10	17255758000	BAND, AIR CLEANER CON. TUBE .....	1	INCLUDES ITEMS W/#
11*	17320ZG5801	CAP, IN.	1	
12*	17330ZG5801	CLAMP ASSY.	1	
13*	90113759003	BOLT, AIR CLEANER	1	
14*	90203ZA0800	WINGNUT, 6MM	1	
15*	90502759003	WASHER, AIR CLEANER	1	
16	95018750250	BAND, AIR CLEANER .....	1	INCLUDES ITEMS W/+
17#	935000402100A	SCREW, PAN 4X20	1	
18+	93500040250G	SCREW, PAN 4X25	1	
19	957010601200	BOLT, FLANGE 6X12	1	

# HONDA GX620TXF2 ENGINE — CAMSHAFT ASSY.

## CAMSHAFT ASSY.

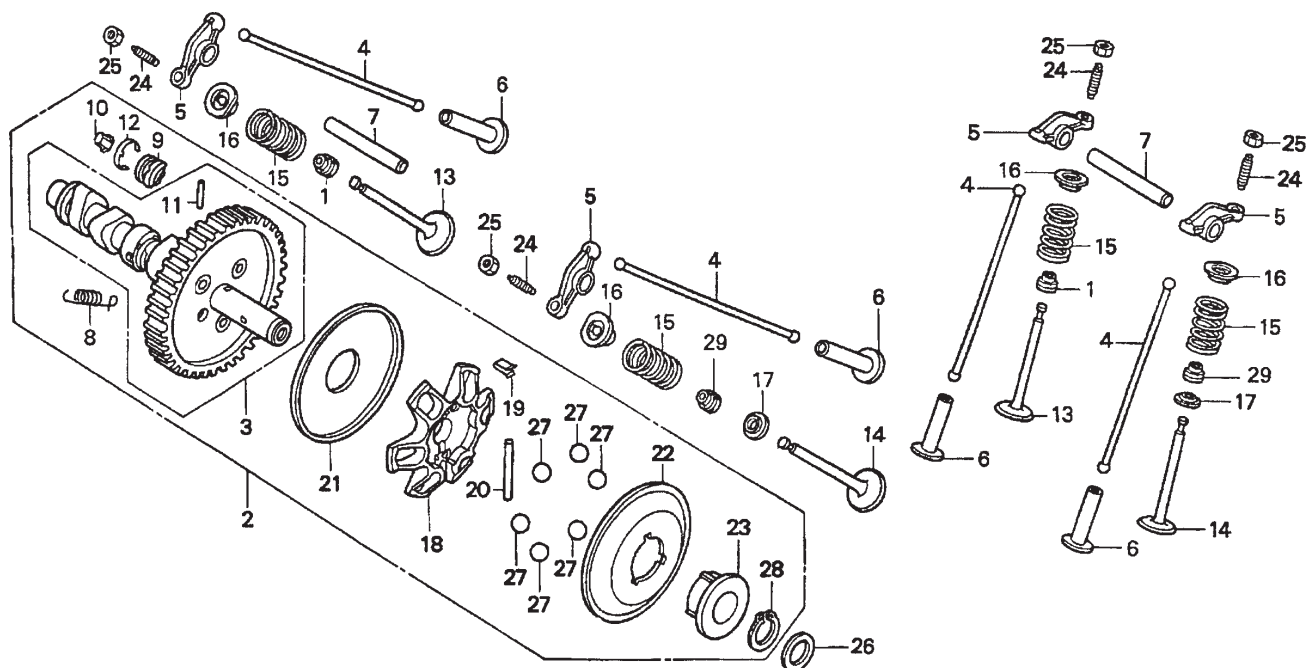

# HONDA GX620TXF2 ENGINE — CAMSHAFT ASSY.

## CAMSHAFT ASSY.

<u>NO</u>	<u>PART NO</u>	<u>PART NAME</u>	<u>QTY.</u>	<u>REMARKS</u>
1	12209ZE8003	SEAL, VALVE STEM	2	
2	14100ZJ1801	CAMSHAFT ASSY. ....	1	INCLUDES ITEMS W/*
3*	14110ZJ1801	CAMSHAFT .....	1	INCLUDES ITEMS W/#
4	14410ZJ1000	ROD, PUSH	4	
5	14431ZJ1000	ARM, VALVE ROCKER	4	
6	14441ZE2000	LIFTER, VALVE	4	
7	14461ZJ1000	SHAFT, ROCKER ARM	2	
8*	14568ZJ1800	SPRING, WEIGHT RETURN	1	
9*	14569ZJ1801	HOLDER, DECOMPRESSION PIN	2	
10*	14576ZJ1801	PIN A, DECOMPRESSION	2	
10*	14577ZJ1801	PIN B, DECOMPRESSION	2	
10*	14578ZJ1801	PIN C, DECOMPRESSION	2	
10*	14579ZJ1801	PIN D, DECOMPRESSION	2	
10*	14580ZJ1801	PIN E, DECOMPRESSION	2	
11*#	14581ZJ1801	ROD, DECOMPRESSION	2	
12*	14586ZJ1800	SPRING, DECOMPRESSION PIN HOLDER	2	
13	14711ZJ1000	VALVE, IN.	2	
14	14721ZJ1000	VALVE, EX.	2	
15	14751ZE2003	SPRING, VALVE	4	
16	14771ZE2000	RETAINER, IN. VALVE SPRING	4	
17	14775ZE2010	SEAT, VALVE SPRING	2	
18*	16512ZJ1000	HOLDER, GOVERNOR WEIGHT	1	
19*	16522ZJ1000	PLATE, GOVERNOR WEIGHT HOLDER	1	
20*	16523ZJ1000	PIN, GOVERNOR WEIGHT HOLDER	1	
21*	16524ZJ1000	PLATE, GOVERNOR LOWER	1	
22*	16529ZJ1000	PLATE, GOVERNOR SLIDER	1	
23*	16531ZJ1003	SLIDER, GOVERNOR	1	
24	90012415000	SCREW, TAPPET ADJ.	4	
25	90206250000	NUT, TAPPET ADJ.	4	
26	90446357000	WASHER, THRUST, 17.12MM	1	
27*	90901ZJ1003	BALL, STEEL, 18	6	
28*	9451017000	CIRCLIP, OUTER 17MM	1	
29	12209ZE8003	SEAL, VALVE STEM	2	

# HONDA GX620TXF2 ENGINE — CONTROL ASSY.

CONTROL ASSY.

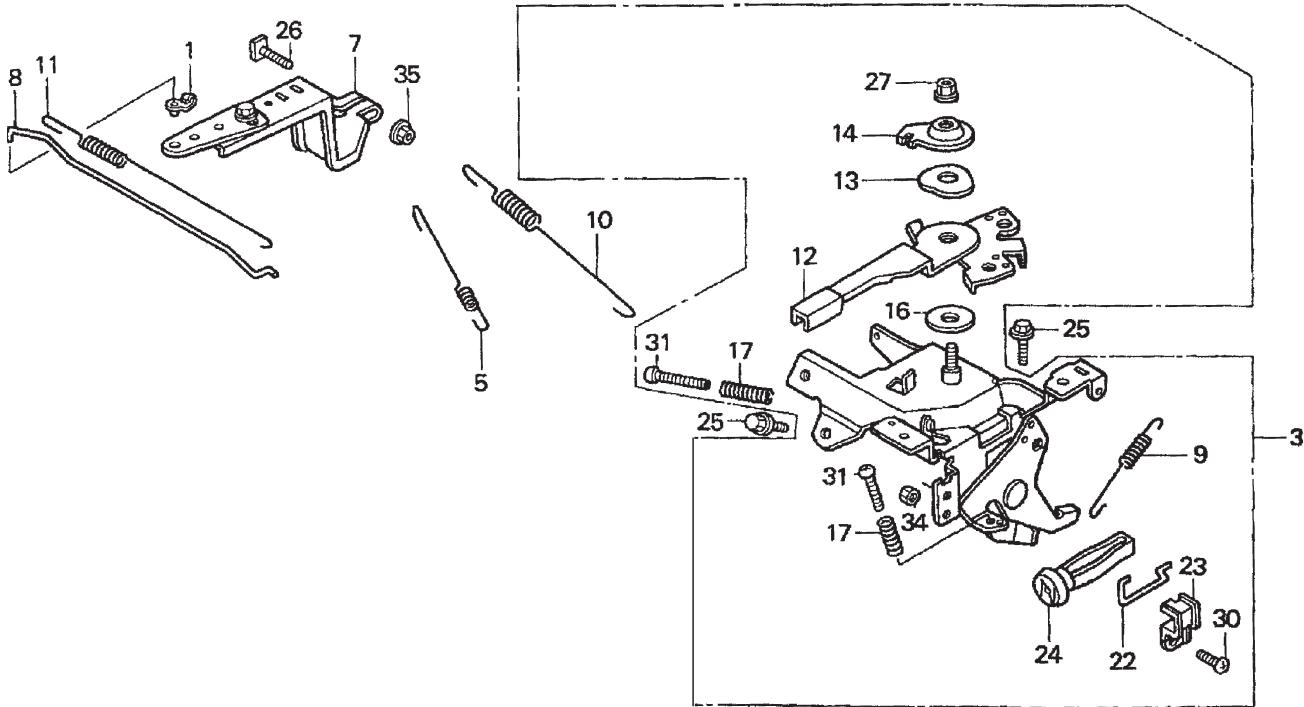

# HONDA GX620TXF2 ENGINE — CONTROL ASSY.

## CONTROL ASSY.

<u>NO</u>	<u>PART NO</u>	<u>PART NAME</u>	<u>QTY.</u>	<u>REMARKS</u>
1	16263ZE3790	JOINT, ROD	1	
3	16500ZJ1000	CONTROL ASSY. ....	1	INCLUDES ITEMS W/*
5	16534ZJ1000	SPRING, STARTER	1	
7	16550ZJ1000	ARM, GOVERNOR	1	
8	16555ZJ1000	ROD, GOVERNOR	1	
9*	16561ZG1000	SPRING GOVERNOR	1	
10	16561ZJ1000	SPRING, GOVERNOR	1	
11	16562ZJ1000	SPRING, THROTTLE RETURN	1	
12*	16570ZJ1000	LEVER CONTROL	1	
13*	16574ZE1000	SPRING, LEVER	1	
14*	16575ZH8000	WASHER, CONTROL LEVER	1	
16*	16578ZE1000	SPACER, CONTROL LEVER	1	
17*	16584883300	SPRING, CONTROL ADJUSTING	2	
22*	16628ZJ1000	ROD, CHOKE KNOB	1	
23	16649ZJ1000	HOLDER, CHOKE KNOB	1	
24*	17951ZG1000	KNOB, CHOKE	1	
25	90013883000	BOLT, FLANGE (6X12)	2	
26	90015ZE3790	BOLT, GOVERNOR ARM	1	
27*	90114SA0000	NUT, SELF-LOCK (6MM)	2	
30*	93500050120H	SCREW, PAN 5X12	2	
31*	93500050250H	SCREW, PAN 5X25	2	
34*	94001050000S	NUT, HEX 5MM	1	
35	9405006000	NUT, FLANGE 6MM	1	

# HONDA GX620TXF2 ENGINE — CONTROL BOX ASSY.

CONTROL BOX ASSY.

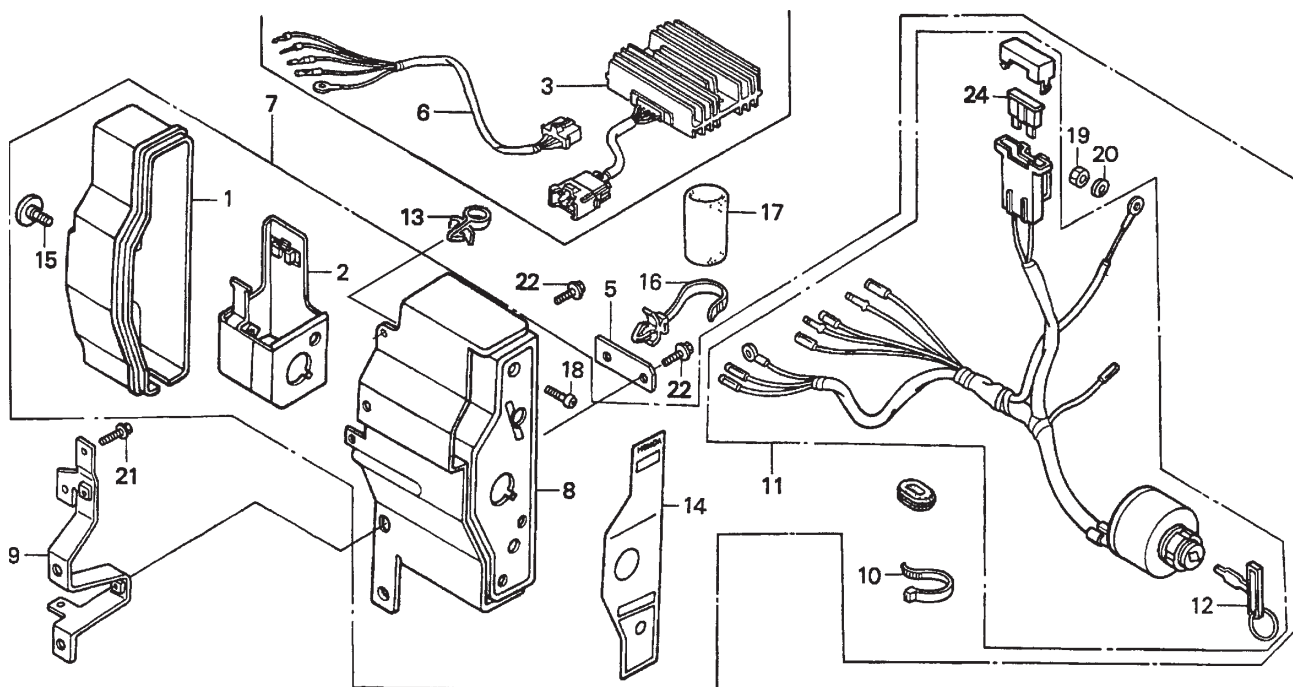

# HONDA GX620TXF2 ENGINE — CONTROL BOX ASSY.

## CONTROL BOX ASSY.

<u>NO</u>	<u>PART NO</u>	<u>PART NAME</u>	<u>QTY.</u>	<u>REMARKS</u>
1*	31612ZE2003	CASE, CONTROL	1	
2*	31614ZE2003	BRACKET, CASE MOUNTING	1	
3	31620ZG5003	RECTIFIER ASSY., REGULATOR 20A	1	
5	32103759000	BRACKET, WIRE HARNESS CLIP	1	
6	29153-501	SUB-WIRE HARNESS ASSY.	1	
7	32340ZJ1812	BOX ASSY., CONTROL .....	1	INCLUDES ITEMS W/*
8*	32345ZJ1811	PANEL, CONTROL	1	
9	29054-001	STAY, CONTROL BOX	1	
10*	32902892003	BAND	1	
11*	35100ZJ1812	SWITCH ASSY., COMBINATION .....	1	INCLUDES ITEMS W/#
12*#	35111880003	KEY	2	
13	36103ZE1000	HOLDER, STOP SWITCH WIRE	1	
14*	87529ZE2860	MARK, CONTROL BOX	1	
		EXTERNAL-REGULATOR		
15	90380MA6010	SCREW, SPECIAL 6X12	1	
16	90676SA8003	BAND, WIRE HARNESS 150MM BLUE	1	
17	91408ZJ1810	TUBE, CORD 30MM	1	
18*	93500040120H	SCREW, PAN 4X12	1	
19	94001043900S	NUT, HEX 4MM NOT AVAILABLE	1	
20	9411104800	WASHER, SPRING 4MM	1	
21	957010601000	BOLT, FLANGE, 6X10	1	
22	957010601200	BOLT FLANGE, 6X12	2	
24*#	9820032500	FUSE, BLADE, 25A	1	

# HONDA GX620TXF2 ENGINE — CRANKCASE COVER ASSY.

CRANKCASE COVER ASSY.

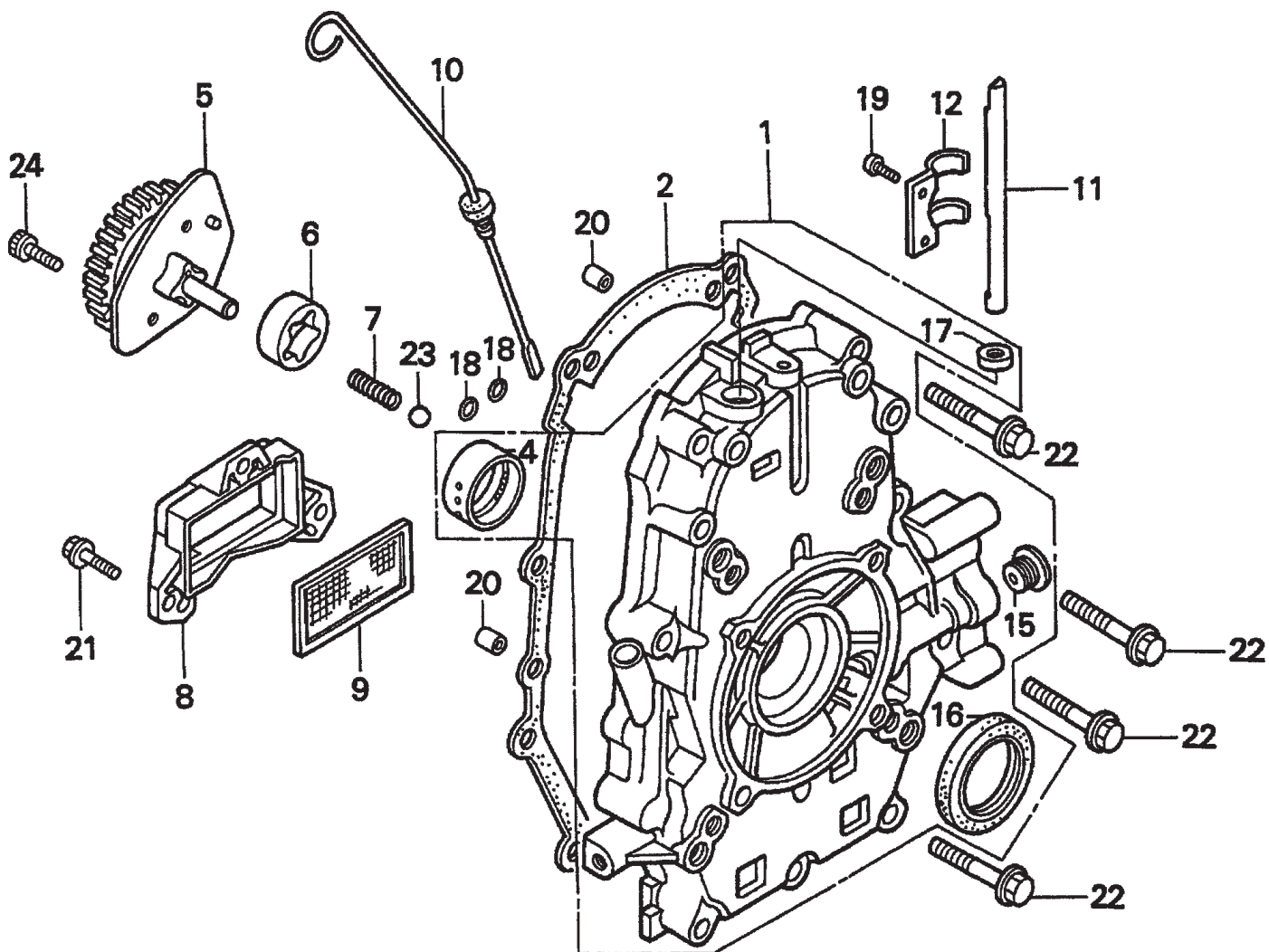



# HONDA GX620TXF2 ENGINE — CRANKCASE COVER ASSY.

## CRANKCASE COVER ASSY.

<u>NO</u>	<u>PART NO</u>	<u>PART NAME</u>	<u>QTY.</u>	<u>REMARKS</u>
1	11300ZJ1600	COVER ASSY., CRANKCASE	1	INCLUDES ITEMS W/*
2	11381ZJ1000	GASKET, CASE COVER	1	
4*	13321ZJ1000	BEARING A, MAIN OPTIONAL	1	SEE HONDA SERVICE MANUAL
4*	13322ZJ1000	BEARING B, MAIN OPTIONAL	1	SEE HONDA SERVICE MANUAL
4*	13323ZJ1000	BEARING C, MAIN OPTIONAL	1	SEE HONDA SERVICE MANUAL
5	15120ZJ1000	COVER ASSY., OIL PUMP	1	
6	15124ZJ1003	ROTOR, OIL PUMP OUTER	1	
7	15232ZJ1000	SPRING, RELIEF VALVE	1	
8	15348ZJ1000	COVER, OIL FILTER	1	
9	15427ZJ1000	SCREEN, OIL FILTER	1	
10	15655ZJ1000	DIPSTICK, OIL	1	
11	16541ZJ1000	SHAFT, GOVERNOR ARM	1	
12	16542ZJ1000	FORK, GOVERNOR	1	
15*	90007ZG8300	BOLT, SEARLING	1	
16*	91201ZJ1003	OIL, SEAL 38X58X11	1	
17*	91259VM0000	OIL, SEAL 10X16X4.5	1	
18	91302MB6830	O-RING 13X3.0	2	
19	93500050100A	SCREW, PAN 5X10	2	
20	9430108140	PIN A, DOWEL 8X14	2	
21	957010602000	BOLT, FLANGE 6X20	3	
22	957010805000	BOLT, FLANGE 8X50	9	
23	9621112000	BALL, STEEL #12, 3/8	1	
24	966000601600	BOLT, SOCKET 6X16	2	

# HONDA GX620TXF2 ENGINE — CRANKSHAFT ASSY.

CRANKSHAFT ASSY.

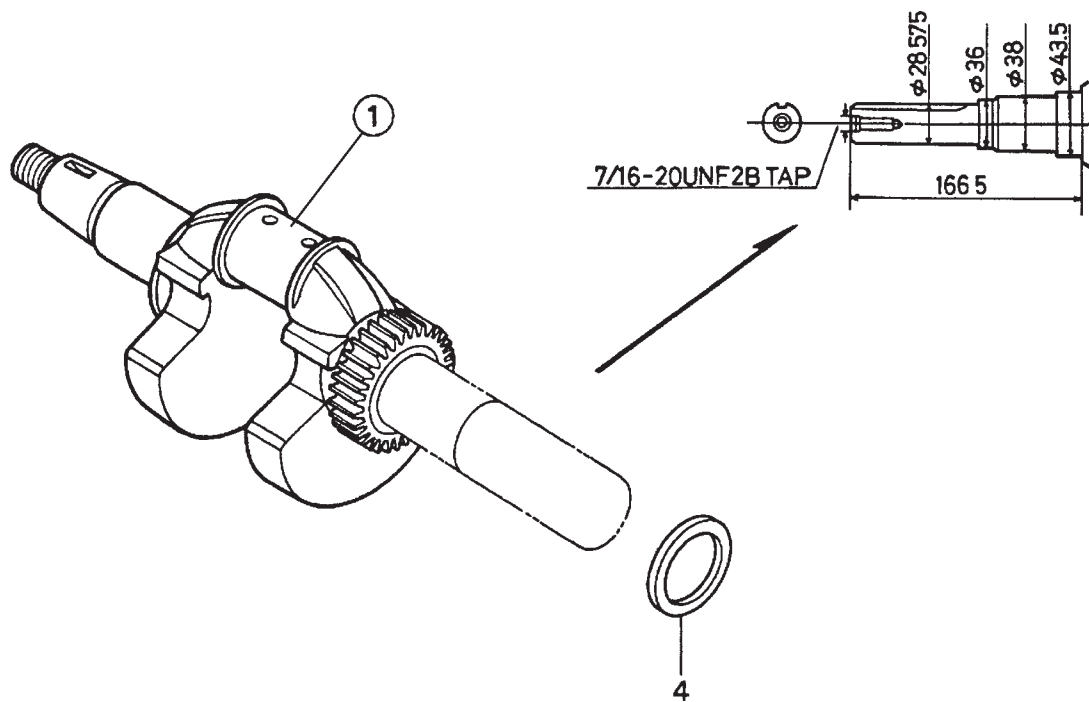

# HONDA GX620TXF2 ENGINE — CRANKSHAFT ASSY.

CRANKSHAFT ASSY.

<u>NO</u>	<u>PART NO</u>	<u>PART NAME</u>	<u>QTY.</u>	<u>REMARKS</u>
1	13310ZJ0U60	CRANKSHAFT, T-TYPE	1	
4	90401ZJ1000	WASHER, CRANKSHAFT THRUST	1	

# HONDA GX620TXF2 ENGINE — CYLINDER BARREL ASSY.

CYLINDER BARREL ASSY.

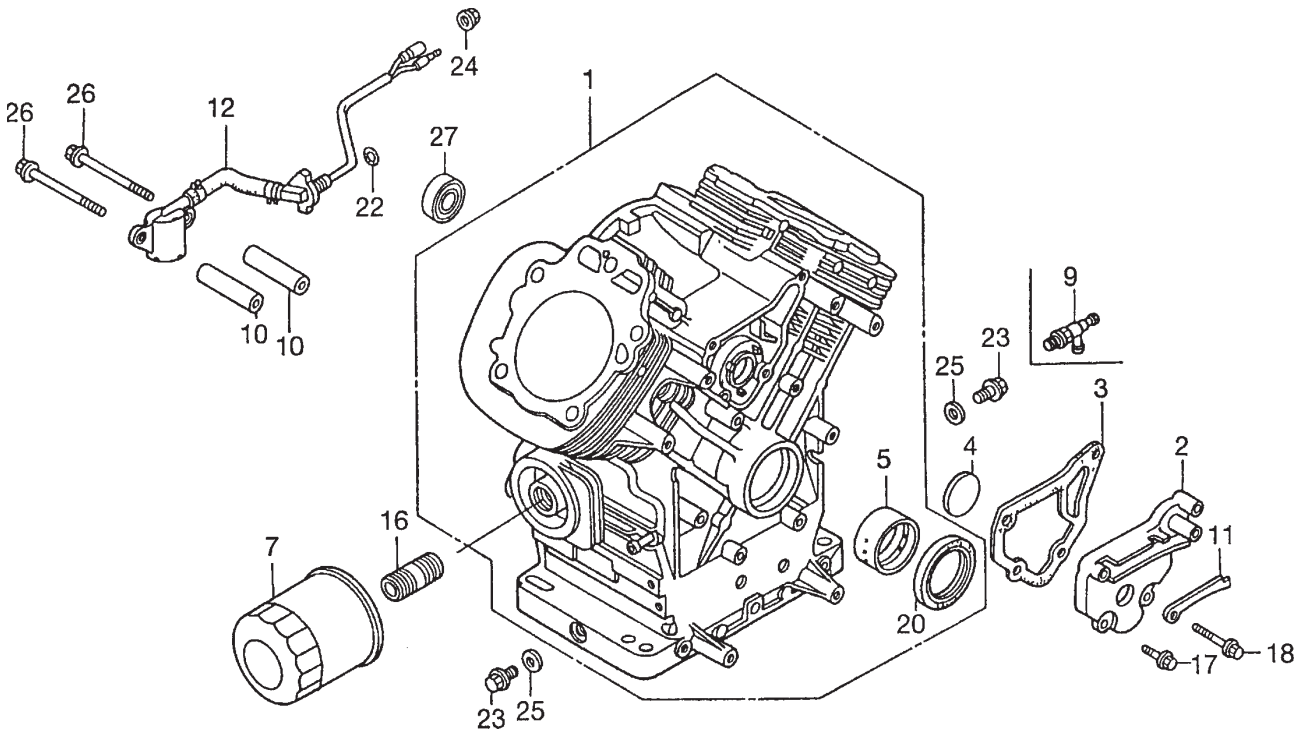

# HONDA GX620TXF2 ENGINE — CYLINDER BARREL ASSY.

## CYLINDER BARREL ASSY.

<u>NO</u>	<u>PART NO</u>	<u>PART NAME</u>	<u>QTY.</u>	<u>REMARKS</u>
1	12000ZJ1810	CYLINDER ASSY. ....	1	INCLUDES ITEMS W/*
2	12356ZJ1000	COVER, BREATHER	1	
3	12358ZJ1000	GASKET, BREATHER COVER	1	
4	12372ZE2300	VALVE, BREATHER	1	
5*	13321ZJ1000	BEARING A, MAIN, OPTIONAL	1	SEE HONDA SERVICE MANUAL
5*	13322ZJ1000	BEARING B, MAIN, OPTIONAL	1	SEE HONDA SERVICE MANUAL
5*	13323ZJ1000	BEARING C, MAIN OPTIONAL	1	SEE HONDA SERVICE MANUAL
7	15400POH305PE	FILTER, OIL	1	
9	15558ZJ1010AH	VALVE, DRAIN 14X1.5 OPTIONAL	1	
10	25523VD6010	COLLAR, FILTER SETTING	2	
11	31511ZJ1000	CLAMP, WIRE	1	
12	35480ZJ1812	SWITCH ASSY., OIL LEVEL	1	
16	90018PN3000	HOLDER, OIL FILTER	1	
17	90029888000	BOLT, FLANGE 6X16	2	
18	90031ZE1000	BOLT, FLANGE 6X32	2	
20*	91201ZJ1003	OIL SEAL, 38X58X11	1	
22	91353671003	O-RING, 13.5X1.5, ARAI	1	
23	9280014000	BOLT, DRAIN PLUG, 14MM	2	
24	9405010000	NUT, FLANGE 10MM	1	
25	9410914000	WASHER, DRAIN PLUG	2	
26	957010607509	BOLT, FLANGE 6X75	2	
27	961406003010	BEARING, RADIAL BALL 6003	1	

# HONDA GX620TXF2 ENGINE — CYLINDER HEAD ASSY.

## CYLINDER HEAD ASSY.

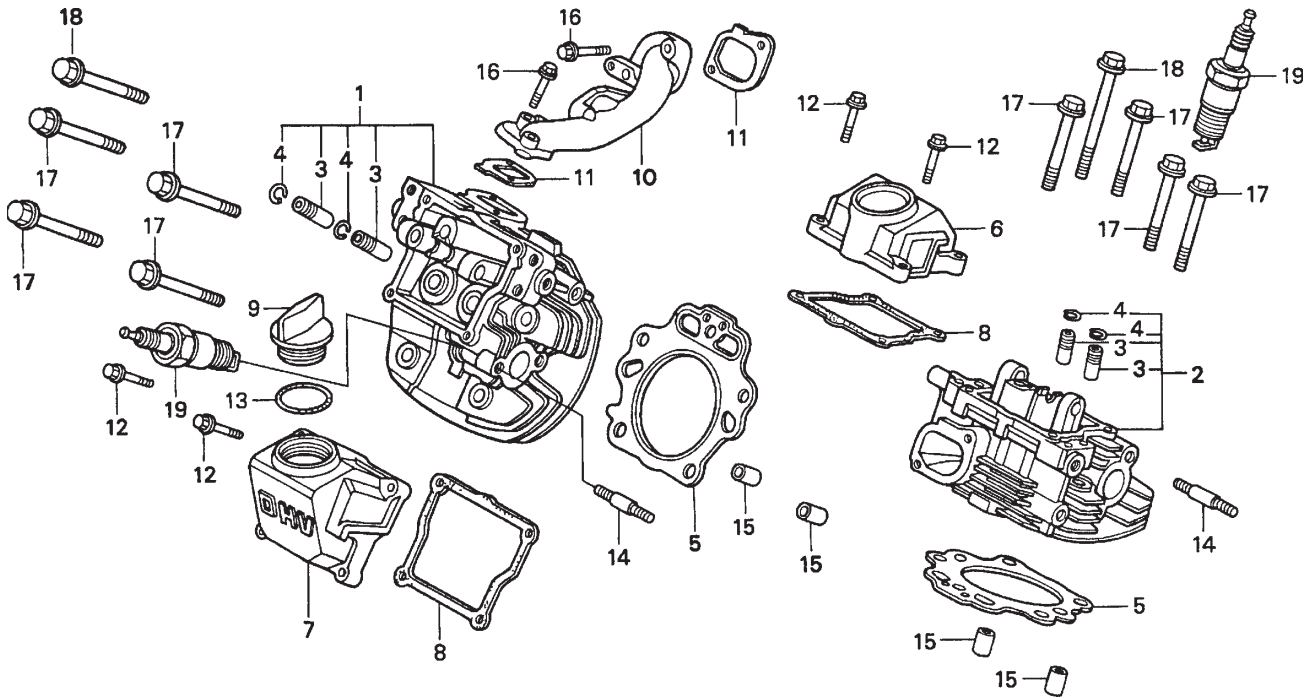

# HONDA GX620TXF2 ENGINE — CYLINDER HEAD ASSY.

## CYLINDER HEAD ASSY.

<u>NO</u>	<u>PART NO</u>	<u>PART NAME</u>	<u>QTY.</u>	<u>REMARKS</u>
1	12210ZJ1000	CYLINDER HEAD, R. ....	1	INCLUDES ITEMS W/*
2	12220ZJ1000	CYLINDER HEAD, L. ....	1	INCLUDES ITEMS W/*
3*	12205ZE2305	GUIDE, EX. VALVE OS OPTIONAL	4	
4*	12216ZE2300	CLIP, VALVE GUIDE	4	
5	12251ZJ1003	GASKET, CYLINDER HEAD	2	
6	12311ZJ1000	COVER, HEAD	1	
7	12314ZJ1000	COVER, HEAD FILLER	1	
8	1239ZJ1000	GASKET, HEAD COVER	2	
9	15611921000	CAP, OIL	1	
10	17101ZJ1000	MANIFOLD, IN	1	
11	17151ZJ1003	GASKET, IN. MANIFOLD	2	
12	90121ZJ1000	BOLT, FLANGE 6X25, CT200	8	
13	91301805000	O-RING 26X2.7	1	
14	92900080250B	BOLT, STUD 8X254	4	
15	9430112200	PIN A, DOWEL 12X20	4	
16	957010603200	BOLT, FLANGE 6X32	4	
17	957011007500	BOLT, FLANGE 10X75	8	
18	957011013000	BOLT, FLANGE 10X130	2	
19	9807956846	SPARK PLUG, BPR6ES NGK	2	

# HONDA GX620TXF2 ENGINE — FAN COVER ASSY.

FAN COVER ASSY.

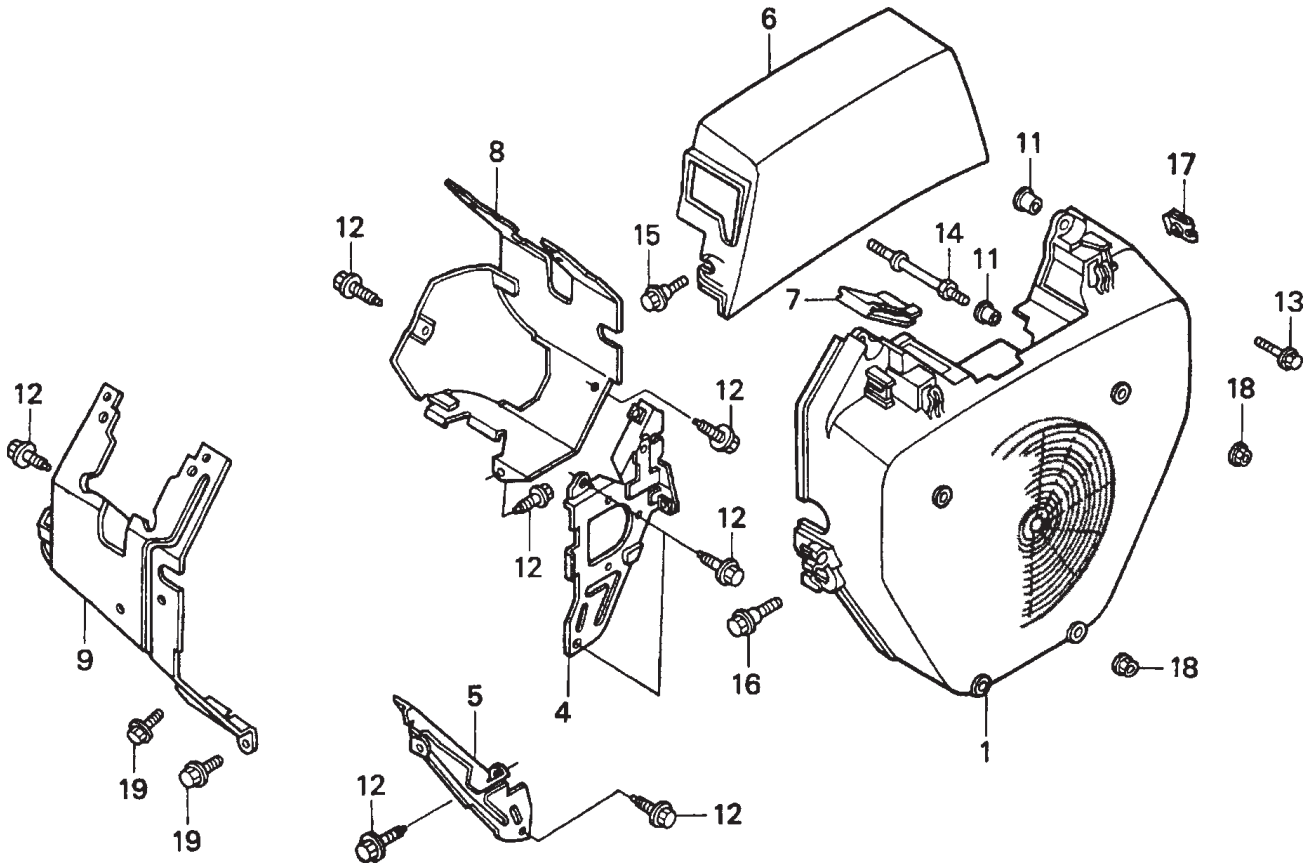



# HONDA GX620TXF2 ENGINE — FAN COVER ASSY.

## FAN COVER ASSY.

<u>NO</u>	<u>PART NO</u>	<u>PART NAME</u>	<u>QTY.</u>	<u>REMARKS</u>
1	19611ZJ1000ZB	COVER, FAN R8, BRIGHT RED	1	
4	19612ZJ1000	PLATE, R SIDE	1	
5	19641ZJ1000	PLATE, L SIDE	1	
6	19615ZJ0U60	HOOD, FAN COVER	1	
6	19615ZJ0U70	HOOD, FAN COVER	1	
7	19618ZJ0U70	PLUG, FAN COVER HOLE	1	
8	19631ZJ1000	SHROUD, R.	1	
9	19632ZJ1000	SHROUD, L.	1	
11	33713GC2000	COLLAR B, TAILLIGHT	6	
12	90013883000	BOLT, FLANGE 6X12, CT200	8	
13	90018ZE1000	BOLT, FLANGE 6X23	2	
14	90042ZJ1000	BOLT, STUD 6X75	4	
15	90104GF6000	BOLT, FLANGE 6X20	2	
16	90113GE4000	BOLT, FLANGE 6MM, BLACK	2	
17	90320MM5000	NUT, SPRING 6MM	2	
18	9405006000	NUT, FLANGE 6MM	4	
19	957010600800	BOLT, FLANGE 6X8	2	

# HONDA GX620TXF2 ENGINE — FLYWHEEL ASSY.

FLYWHEEL ASSY.

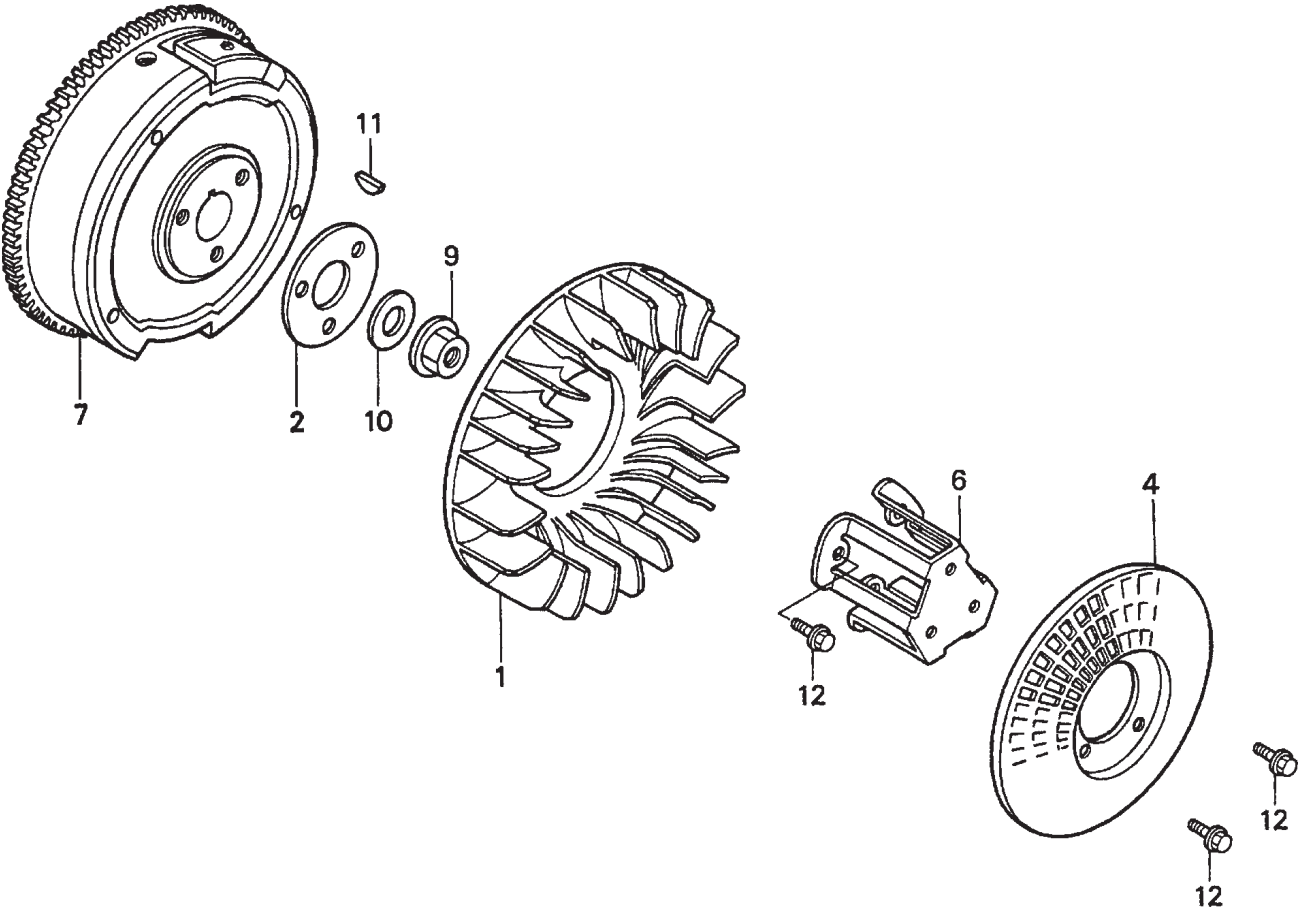

# HONDA GX620TXF2 ENGINE — FLYWHEEL ASSY.

FLYWHEEL ASSY.

<u>NO</u>	<u>PART NO</u>	<u>PART NAME</u>	<u>QTY.</u>	<u>REMARKS</u>
1	19511ZJ1000	FAN, COOLING	1	
2	19513ZJ1000	PLATE, COOLING FAN START	1	
4	28452ZJ1811	GRID, SCREEN P.T.O.	1	
6	28454ZJ1801	HOLDER, SCREEN GRID OPTIONAL	1	
7	31110ZJ1801	FLYWHEEL	1	
9	90201ZG3000	NUT, FLANGE 20MM	1	
10	90401ZG3000	WASHER, 20MM	1	
11	90741ZE2000	KEY, SPECIAL WOODRUFF 25X18	1	
12	957010801600	BOLT, FLANGE 8X16	4	

# HONDA GX620TXF2 ENGINE — IGNITION COIL ASSY.

IGNITION COIL ASSY.

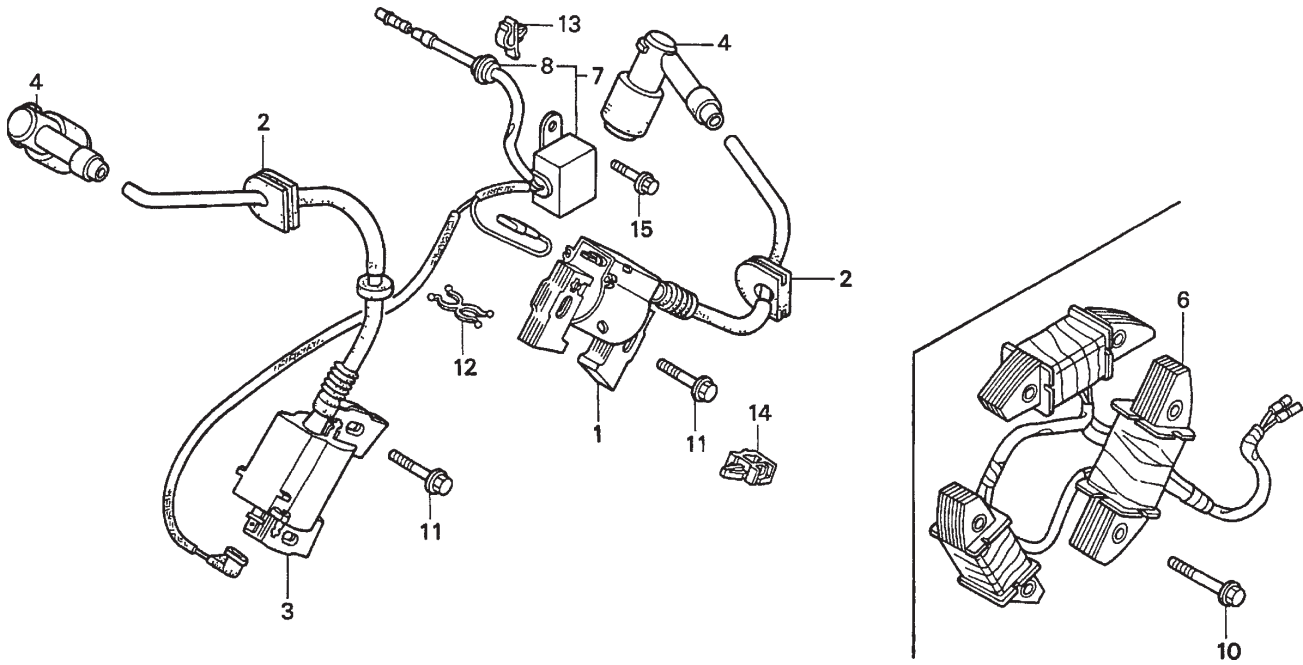

# HONDA GX620TXF2 ENGINE — IGNITION COIL ASSY.

## IGNITION COIL ASSY.

<u>NO</u>	<u>PART NO</u>	<u>PART NAME</u>	<u>QTY.</u>	<u>REMARKS</u>
1	30500ZJ1013	COIL ASSY., R. IGNITION	1	
2	30518ZJ1000	GROMMET, IGNITION WIRE	2	
3	30550ZJ1013	COIL ASSY., L. IGNITION	1	
4	30700ZJ1003	CAP ASSY., NOISE SUPPRESSOR	2	
6	31630ZJ1801	COIL ASSY., CHARGHE	1	
7	31740ZJ1003	DIODE ASSY., ENGINE STOP .....	1	INCLUDES ITEMS W/*
8*	63312ZA7000	GROMMET, TOOL	1	
10	90031ZE1000	BOLT, FLANGE 6X32	6	
11	90121952000	BOLT, FLANGE 6X25	2	
12	90658SA0003	CLIP, WIRE HARNESS	1	
13	90673GJ5003	CLIP, CORD	1	
14	915047540003	CLIP, WIRE HARNESS	1	
15	957010600800	BOLT, FLANGE 6X8	1	

# HONDA GX620TXF2 ENGINE — MUFFLER ASSY.

MUFFLER ASSY.

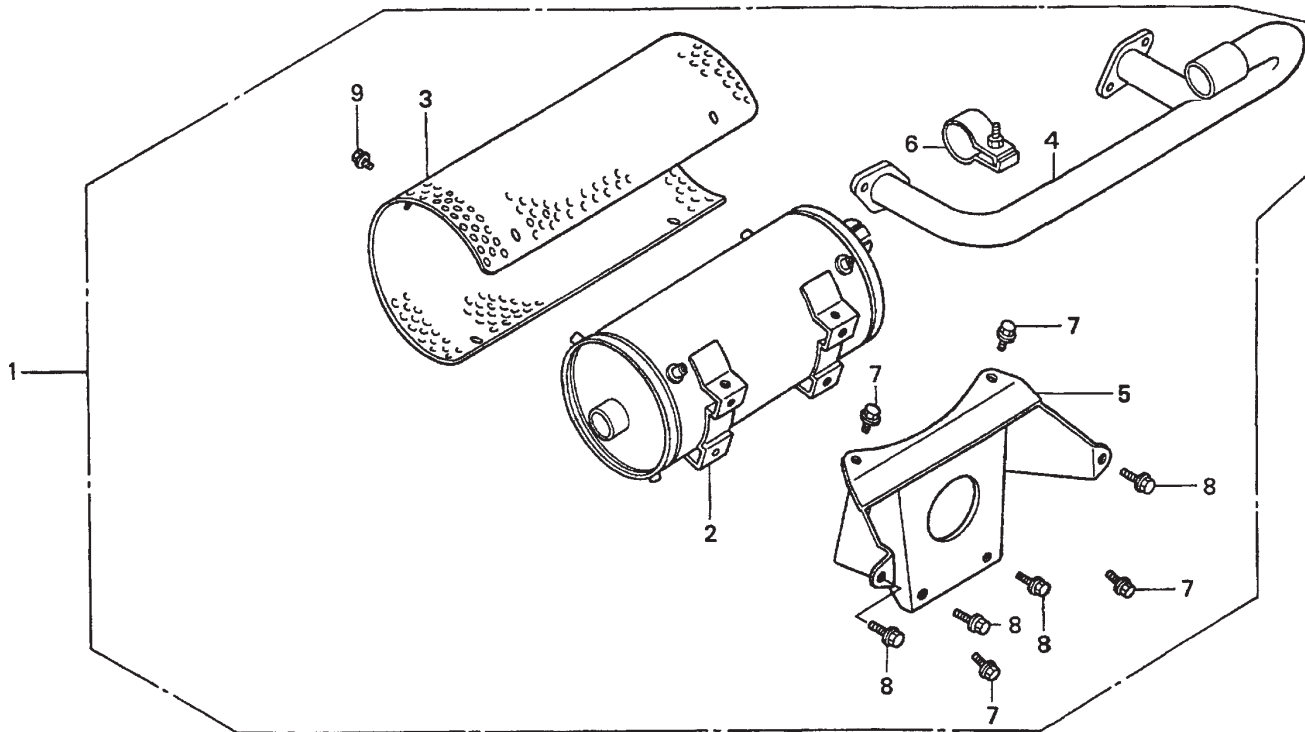

# HONDA GX620TXF2 ENGINE — MUFFLER ASSY.

## MUFFLER ASSY.

<u>NO</u>	<u>PART NO</u>	<u>PART NAME</u>	<u>QTY.</u>	<u>REMARKS</u>
1	06183ZJ1821	MUFFLER KIT, HIGH-B OPTIONAL.....	1	INCLUDES ITEMS W/*
2*	18310ZJ1003	MUFFLER, HIGH OPTIONAL	1	
3*	18321ZJ1003	PROTECTOR, MUFF., HIGH OPTIONAL	1	
4*	18330ZJ1600	PIPE, EX. HIGH-L OPTIONAL	1	
5*	18338ZJ1003	STAY, MUFFLER, HIGH OPTIONAL	1	
6*	18396ZJ1003	BAND ASSY. OPTIONAL	1	
7*	957010600800	BOLT, FLANGE 6X8 OPTIONAL	6	
8*	957010801400	BOLT, FLANGE 8X14 OPTIONAL	4	
9*	957010802000	BOLT, FLANGE 8X20 OPTIONAL	4	

# HONDA GX620TXF2 ENGINE — PISTON AND CONNECTING ROD ASSY.

PISTON & CONNECTING ROD ASSY.

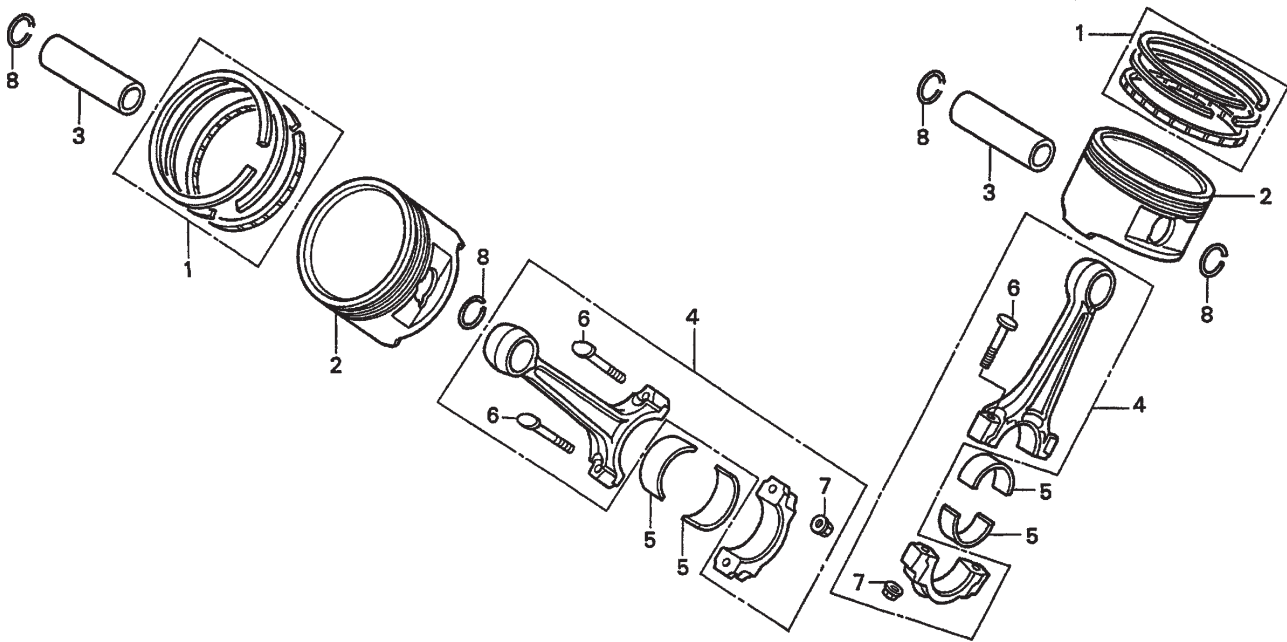



# HONDA GX620TXF2 ENGINE — PISTON AND CONNECTING ROD ASSY.

## PISTON & CONNECTING ROD ASSY.

<u>NO</u>	<u>PART NO</u>	<u>PART NAME</u>	<u>QTY.</u>	<u>REMARKS</u>
1	13010ZE8601	RING SET, PISTON STANDARD	2	
1	13011ZE8601	RING SET, PISTON OS 0.25 .....	2	OPTIONAL
1	13012ZE8601	RING SET, PISTON OS .050 .....	2	OPTIONAL
1	13013ZE8601	RING SET, PISTON OS .075 .....	2	OPTIONAL
2	13101ZJ1000	PISTON	2	
2	13102ZJ1000	PISTON, OS 0.25 .....	2	OPTIONAL
2	13103ZJ1000	PISTON, OS 0.50 .....	2	OPTIONAL
2	13104ZJ1000	PISTON, OS .075 .....	2	OPTIONAL
3	13111ZJ1000	PIN, PISTON	2	
4	13210ZJ1000	ROD SET, CONNECTING .....	2	INCLUDES ITEMS W/*
5	13211ZJ1003	BEARING A, CONNECTING ROD BLUE .....	4	
5	13212ZJ1003	BEARING B, CONNECTING ROD BLACK	4	
5	13213ZJ1003	BEARING C, CONNECTING ROD BROWN	4	
5	13214ZJ1003	BEARING D, CONNECTING ROD GREEN	4	
5	13215ZJ1003	BEARING E, CONNECTING ROD YELLOW	4	
5	13216ZJ1003	BEARING F, CONNECTING ROD PINK	4	
5	13217ZJ1003	BEARING G, CONNECTING ROD RED	4	
6*	13213ML0000	BOLT, CONNECTING ROD	4	
7*	1312KM3000	NUT, CONNECTING ROD	4	
8	90551ZE1000	CLIP, PISTON PIN 18MM	4	

# HONDA GX620TXF2 ENGINE — FUEL TANK ASSY.

FUEL TANK ASSY.

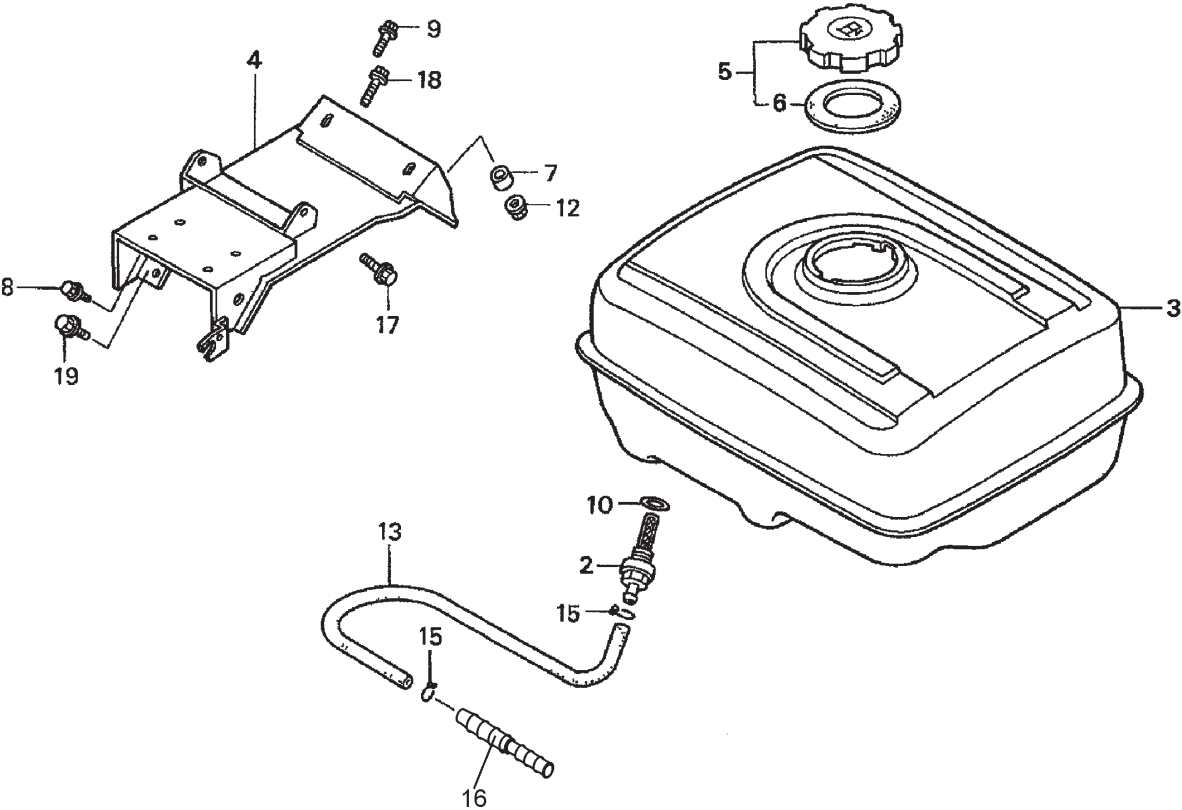

# HONDA GX620TXF2 ENGINE — FUEL TANK ASSY.

## FUEL TANK ASSY.

<u>NO</u>	<u>PART NO</u>	<u>PART NAME</u>	<u>QTY.</u>	<u>REMARKS</u>
2	15282	JOINT, FUEL TANK	1	
3	17510ZE3010ZB	FUEL TANK	1	
4	17560ZJ0U70	SUPPORT, FUEL TANK	1	
5	17620ZH7023	CAP, FUEL	1	
6	17631ZH7023	GASKET, FUEL FILLER CAP	1	
7	29219-001	COLLAR, FR. ENGINE HANGER	1	
8	90018ZE1000	BOLT, FLANGE (6X23)	1	
9	90022888010	BOLT, FLANGE (6X20)	1	
10	15229	O-RING (13.5X1.5)	1	
12	9405008000	NUT, FLANGE	2	
13	6004	HOSE, 3/16"	1 FT.	
15	22994-010	CLIP, HOSE	2	
16	29066-001	REDUCER	1	
17	957010801600	BOLT, FLANGE (8X16)	2	
18	957010802500	BOLT, FLANGE (8X25)	2	
19	957010803000	BOLT, FLANGE (8X30)	2	

# HONDA GX620TXF2 ENGINE — FUEL PUMP ASSY.

FUEL PUMP ASSY.

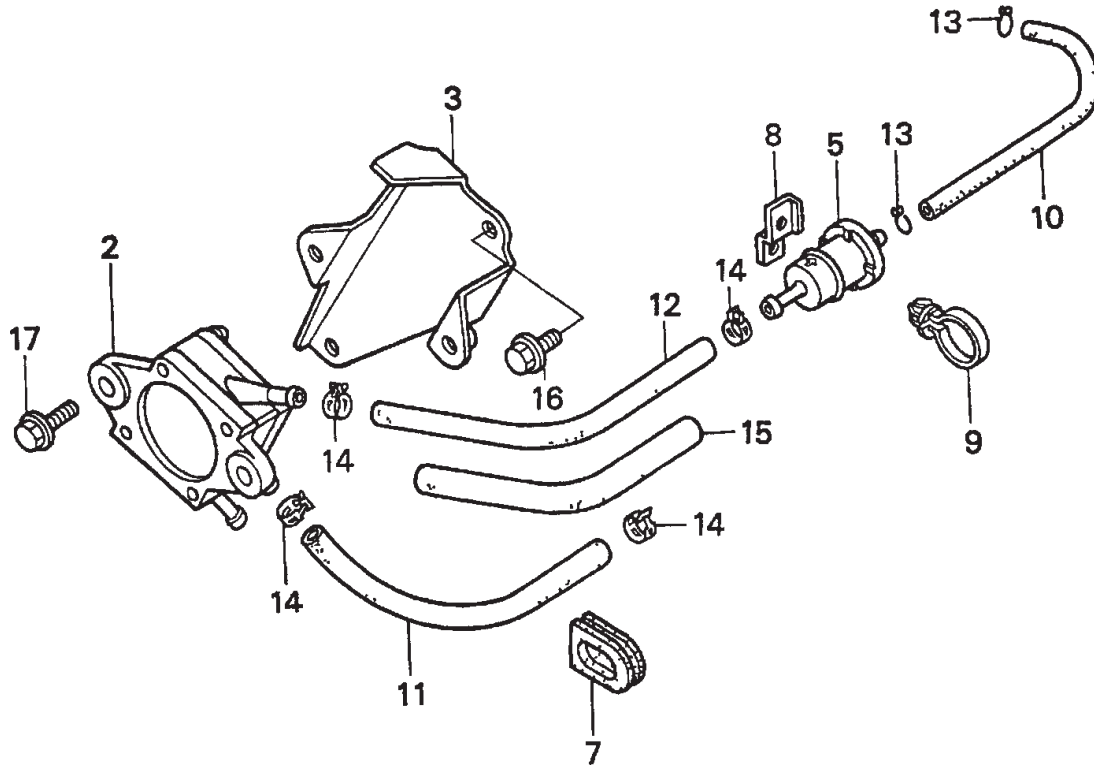

# HONDA GX620TXF2 ENGINE — FUEL PUMP ASSY.

## FUEL PUMP ASSY.

<u>NO</u>	<u>PART NO</u>	<u>PART NAME</u>	<u>QTY.</u>	<u>REMARKS</u>
2	16700ZJ1003	PUMP ASSY., FUEL	1	
3	16711ZJ1800	STAY, FUEL PUMP	1	
5	16910ZE8015	FILTER, FUEL	1	
7	19905ZA8701	GROMMET, WIRE	1	
8	35806752630	BASE, CLIP	1	
9	90617SA0003	CLIP, WIRE HARNESS	1	
10	950014500360M	BULK HOSE, FUEL 4.5X3000 X 4.5X110	1	
11	950015500840M	BULK HOSE, FUEL 5.5X8000 X 5.5X195	1	
12	950015500840M	BULK HOSE, FUEL 5.5X8000 X 5.5X215	1	
13	9500202080	CLIP, TUBE B8	2	
14	950024105008	CLIP, TUBE 10.5MM	4	
15	950033600310M	BULK HOSE, VINYL 11X13X3000 X 11X13X160	1	
16	957010600800	BOLT, FLANGE 6X8	2	
17	957010601400	BOLT, FLANGE 6X14	2	

# HONDA GX620TXF2 ENGINE — CARBURETOR ASSY.

## CARBURETOR ASSY.

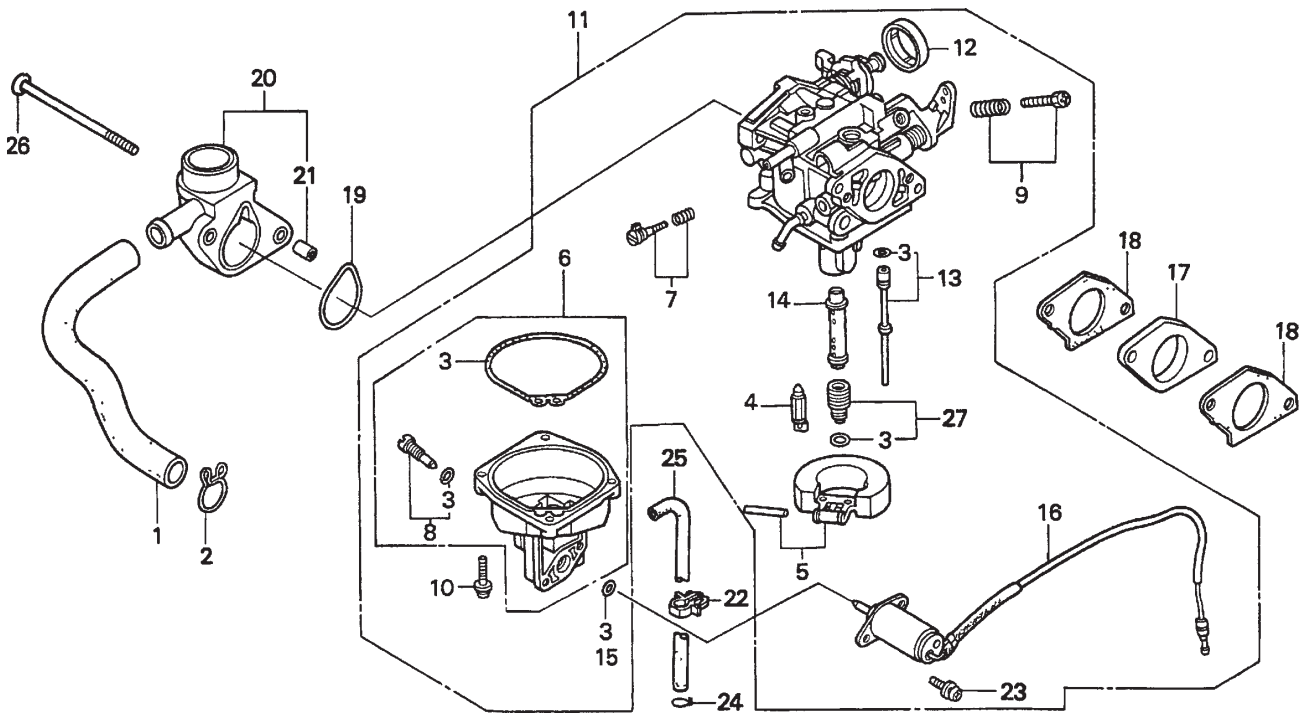

# HONDA GX620TXF2 ENGINE — CARBURETOR ASSY.

## CARBURETOR ASSY.

<u>NO</u>	<u>PART NO</u>	<u>PART NAME</u>	<u>QTY.</u>	<u>REMARKS</u>
1	12357ZJ1000	TUBE, BREATHER	1	
2	15772551000	CLIP, BREATHER TUBE	1	
3*#	16010ZG8000	GASKET SET	1	
4*	16011382004	VALVE SET, FLOAT	1	
5*	16013ZV4005	FLOAT SET	1	
6*	16015ZJ1000	CHAMBER SET, FLOAT .....	1	INCLUDES ITEMS W/#
7*	16016ZJ1010	SCREW SET	1	
8*#	16024124760	SCREW SET, DRAIN	1	
9*	16028ZG8000	SCREW SET	1	
10*	16081ZV4650	SCREW WASHER	4	
11	16100ZJ1023	CARBURETOR ASSY., BG224A C .....	1	INCLUDES ITEMS W/*
12*	161748141881	CAP, CHOKE LEVER DUST	1	
13*	16150ZJ1010	JET SET, #45	1	
14*	16166ZJ1010	NOZZLE, MAIN	1	
15*	16178548004	O-RING, 5.8X1.9	1	
16*	16200ZJ1003	VALVE ASSY., SOLENOID	1	
17	16211ZJ1000	INSULATOR, CARBURETOR	1	
18	16221ZG8000	GASKET, CARBURETOR	2	
19	17228ZG8003	GASKET, AIR CLEANER	1	
20	17410ZJ1000	ELBOW, AIR CLEANER .....	1	INCLUDES ITEMS W/+
21+	19024ZA0000	COLLAR, DISTANCE	2	
22	90682959661	CLIP B, CABLE	1	
23*	938920501208	SCREW WASHER, 5X12	2	
24	9500202080	CLIP, TUBE B8	1	
25	950054500120M	BULK HOSE, VAC. 4.5X1000 X 4.5X460	1	
26	958010610508	BOLT, FLANGE 6X105	2	
27	99201ZG80900	JET SET, MAIN #90 .....	1	OPTIONAL
27	99201ZG80920	JET SET, MAIN #92 .....	1	OPTIONAL
27*	99201ZG80950	JET SET, MAIN #95	1	

# HONDA GX620TXF2 ENGINE — STARTER MOTOR ASSY.

STARTER MOTOR ASSY.

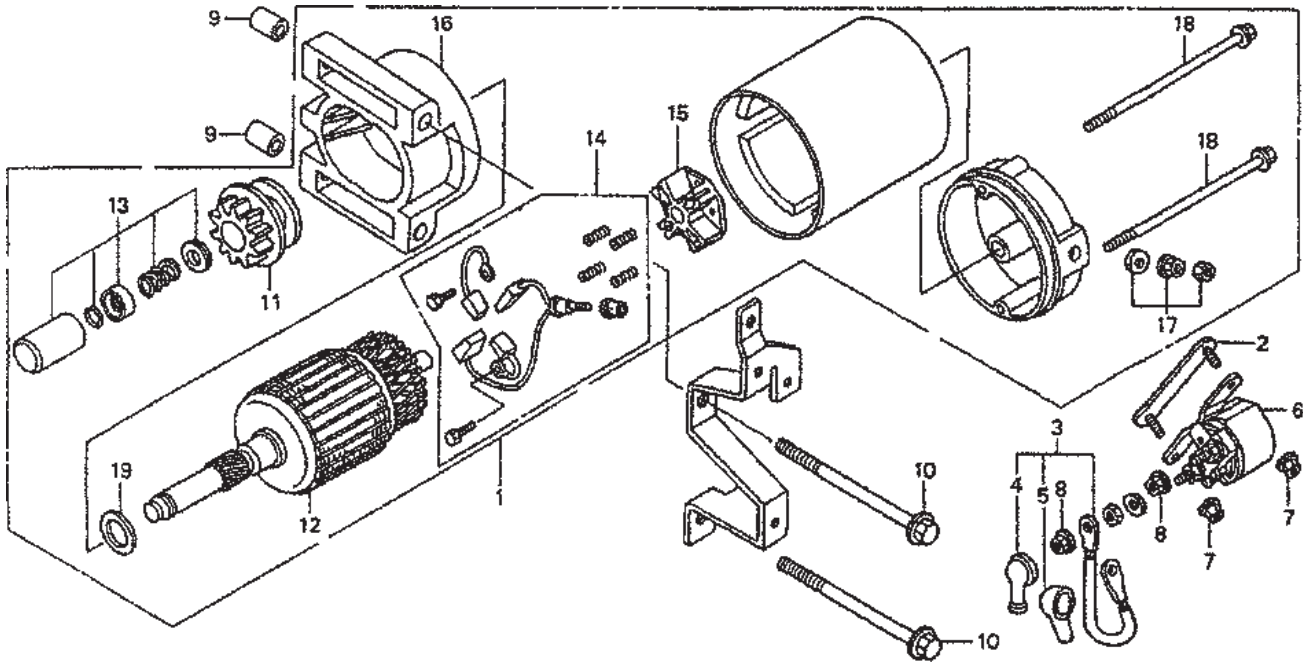



# HONDA GX620TXF2 ENGINE — STARTER MOTOR ASSY.

## STARTER MOTOR ASSY.

<u>NO</u>	<u>PART NO</u>	<u>PART NAME</u>	<u>QTY.</u>	<u>REMARKS</u>
1	31200ZJ1004	MOTOR ASSY., STARTER .....	1	INCLUDES ITEMS W/*
2	31243ZJ1800	BRACKET, STARTER MAGNETIC SETTING ...	1	INCLUDES ITEMS W/+
3	32402ZJ1810	CABLE, MAGNET SWITCH .....	1	
4+	32411KB9930	COVER A. MAGNETIC SWITCH	1	
5+	32411402000	COVER, STARTER MOTOR TERMINAL	1	
6	35850ZJ1811	SWITCH ASSY., STARTER MAGNETIC	1	
7	94050060000	NUT, FLANGE 6MM	2	
8+	9407006080	NUT, WASHER 6MM	2	
9	9430110120	PIN, DOWEL 10X12	2	
10	957010811000	BOLT, FLANGE 8X110	2	
11*	31213ZJ1004	GEAR SET, PINION	1	
12*	31217ZJ1004	ARMATURE	1	
13*	31225ZJ1004	STOPPER SET, PINION	1	
14*	31226ZJ1004	BRUSH SET	1	
15*	31231ZJ1004	HOLDER, BRUSH	1	
16*	31235ZJ1004	BRACKET, FR.	1	
17*	31237ZJ1004	NUT SET, TERMINAL	1	
18*	31281ZJ1004	BOLT, THROUGH	2	
19*	90407ZJ1004	WASHER, THRUST	1	

GASKET KIT ASSY.

**NO ARTWORK AVAILABLE**

## HONDA GX620TXF2 ENGINE — GASKET KIT ASSY.

### GASKET KIT ASSY.

<u>NO</u>	<u>PART NO</u>	<u>PART NAME</u>	<u>QTY.</u>	<u>REMARKS</u>
1	061A1ZJ1000	GASKET KIT .....	1 .....	INCLUDES ITEMS W/*
2*	12251ZJ1003	GASKET, CYLINDER HEAD	2	
3*	12358ZJ1000	GASKET, BREATHER COVER	1	
4*	12391ZJ1000	GASKET, HEAD COVER	2	
5*	16221ZG8000	GASKET, CARBURETOR	2	
6*	171541ZJ1003	GASKET, IN. MANIFOLD	2	
7*	17228ZG8003	GASKET, AIR CLEANER	1	
8*	18333ZJ1000	GASKET, EX. PIPE	2	
9*	91301805000	O-RING, 26X2.7	1	

# HONDA GX620TXF2 ENGINE — LABEL ASSY.

LABEL ASSY.

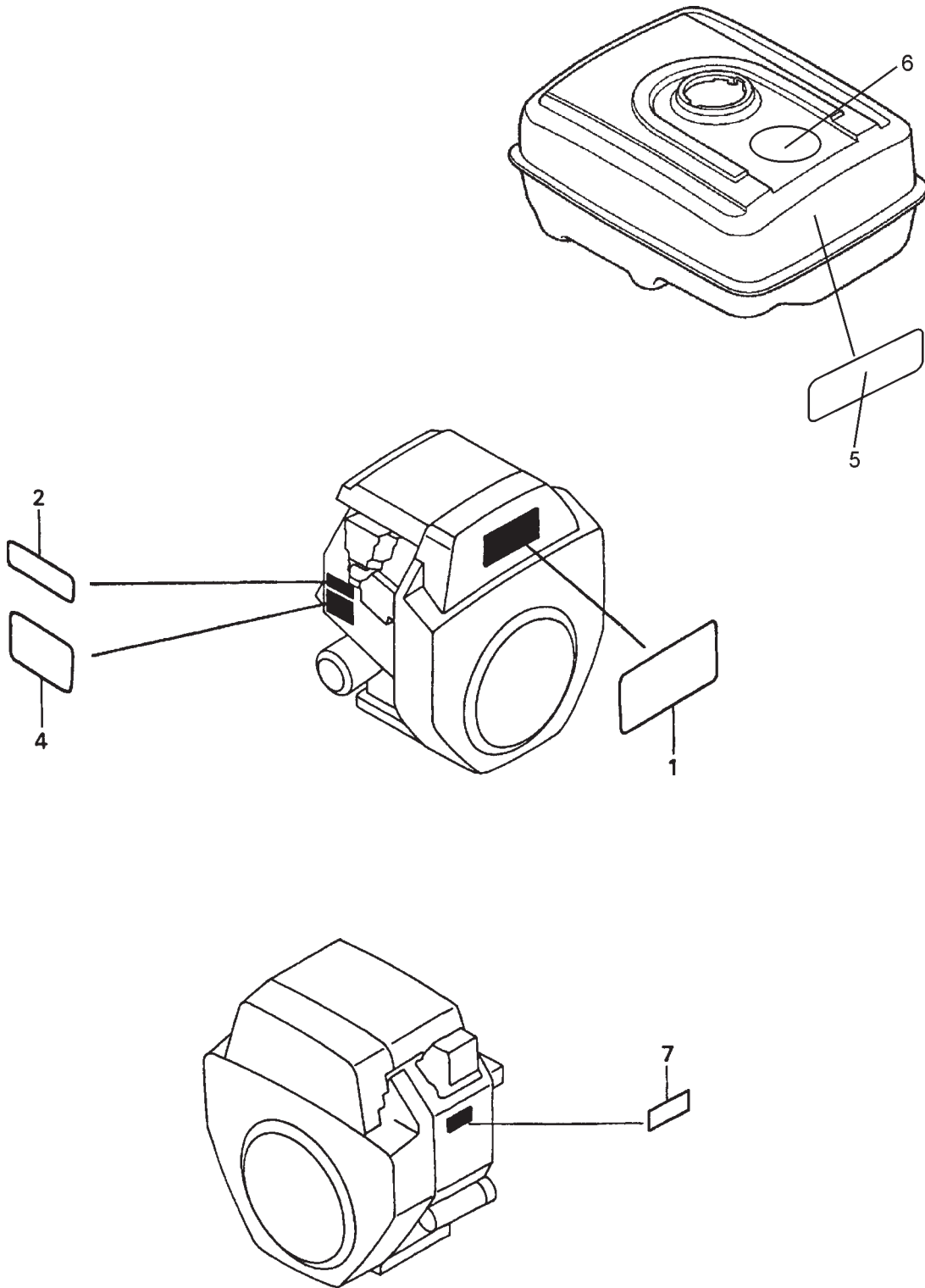

LABEL ASSY.

<u>NO</u>	<u>PART NO</u>	<u>PART NAME</u>	<u>QTY.</u>	<u>REMARKS</u>
1	87101ZJ1000	MARK, EMBLEM, GX620	1	
2	87152ZJ1000	LABEL, SPECIFICATION GX620	1	
4	87522ZJ1000	LABEL, CAUTION	1	
5	22994-012	LABEL READ OWNER'S MANUAL	1	
6	22994-013	LABEL, GAS TANK (MATCH/FLAME)	1	
7	87532ZH8810	MARK, OIL ALERT( E)	1	

**PAYMENT TERMS**

Terms of payment for parts are net 30 days.

**FREIGHT POLICY**

All parts orders will be shipped collect or prepaid with the charges added to the invoice. All shipments are F.O.B. point of origin. Multiquip's responsibility ceases when a signed manifest has been obtained from the carrier, and any claim for shortage or damage must be settled between the consignee and the carrier.

**MINIMUM ORDER**

The minimum charge for orders from Multiquip is \$15.00 net. Customers will be asked for instructions regarding handling of orders not meeting this requirement.

**RETURNED GOODS POLICY**

Return shipments will be accepted and credit will be allowed, subject to the following provisions:

1. A Returned Material Authorization must be approved by Multiquip prior to shipment.
2. To obtain a Return Material Authorization, a list must be provided to Multiquip Parts Sales that defines item numbers, quantities, and descriptions of the items to be returned.
  - a. The parts numbers and descriptions must match the current parts price list.
  - b. The list must be typed or computer generated.
  - c. The list must state the reason(s) for the return.
  - d. The list must reference the sales order(s) or invoice(s) under which the items were originally purchased.
  - e. The list must include the name and phone number of the person requesting the RMA.
3. A copy of the Return Material Authorization must accompany the return shipment.
4. Freight is at the sender's expense. All parts must be returned freight prepaid to Multiquip's designated receiving point.

5. Parts must be in new and resalable condition, in the original Multiquip package (if any), and with Multiquip part numbers clearly marked.
6. The following items are not returnable:
  - a. Obsolete parts. (If an item is in the price book and shows as being replaced by another item, it is obsolete.)
  - b. Any parts with a limited shelf life (such as gaskets, seals, "O" rings, and other rubber parts) that were purchased more than six months prior to the return date.
  - c. Any line item with an extended dealer net price of less than \$5.00.
  - d. Special order items.
  - e. Electrical components.
  - f. Paint, chemicals, and lubricants.
  - g. Decals and paper products.
  - h. Items purchased in kits.
7. The sender will be notified of any material received that is not acceptable.
8. Such material will be held for five working days from notification, pending instructions. If a reply is not received within five days, the material will be returned to the sender at his expense.
9. Credit on returned parts will be issued at dealer net price at time of the original purchase, less a 15% restocking charge.
10. In cases where an item is accepted, for which the original purchase document can not be determined, the price will be based on the list price that was effective twelve months prior to the RMA date.
11. Credit issued will be applied to future purchases only.

**PRICING AND REBATES**

Prices are subject to change without prior notice. Price changes are effective on a specific date and all orders received on or after that date will be billed at the revised price. Rebates for price declines and added charges for price increases will not be made for stock on hand at the time of any price change.

Multiquip reserves the right to quote and sell direct to Government agencies, and to Original Equipment Manufacturer accounts who use our products as integral parts of their own products.

**SPECIAL EXPEDITING SERVICE**

A \$35.00 surcharge will be added to the invoice for special handling including bus shipments, insured parcel post or in cases where Multiquip must personally deliver the parts to the carrier.

**LIMITATIONS OF SELLER'S LIABILITY**

Multiquip shall not be liable hereunder for damages in excess of the purchase price of the item with respect to which damages are claimed, and in no event shall Multiquip be liable for loss of profit or good will or for any other special, consequential or incidental damages.

**LIMITATION OF WARRANTIES**

No warranties, express or implied, are made in connection with the sale of parts or trade accessories nor as to any engine not manufactured by Multiquip. Such warranties made in connection with the sale of new, complete units are made exclusively by a statement of warranty packaged with such units, and Multiquip neither assumes nor authorizes any person to assume for it any other obligation or liability whatever in connection with the sale of its products. Apart from such written statement of warranty, there are no warranties, express, implied or statutory, which extend beyond the description of the products on the face hereof.



# OPERATION AND PARTS MANUAL

## HERE'S HOW TO GET HELP

PLEASE HAVE THE MODEL AND SERIAL  
NUMBER *ON-HAND* WHEN CALLING

### UNITED STATES

#### **Multiquip Corporate Office**

18910 Wilmington Ave. Tel: (800) 421-1244  
Carson, CA 90746 Fax (800) 537-3927  
Contact: mq@multiquip.com

#### **Mayco Parts**

800-306-2926 Fax: 800-672-7877  
310-537-3700 Fax: 310-637-3284

#### **Service Department**

800-421-1244 Fax: 310-537-4259  
310-537-3700

#### **MQ Parts Department**

800-427-1244 Fax: 800-672-7877  
310-537-3700 Fax: 310-637-3284

#### **Warranty Department**

800-421-1244, Ext. 279 Fax: 310-537-1173  
310-537-3700, Ext. 279

#### **Technical Assistance**

800-478-1244 Fax: 310-631-5032

### MEXICO

#### **MQ Cipsa**

Carr. Fed. Mexico-Puebla KM 126.5 Tel: (52) 222-225-9900  
Momoxpan, Cholula, Puebla 72760 Mexico Fax: (52) 222-285-0420  
Contact: pmastretta@cipsa.com.mx

### CANADA

#### **Multiquip**

4110 Industriel Boul. Tel: (450) 625-2244  
Laval, Quebec, Canada H7L 6V3 Fax: (450) 625-8664  
Contact: jmartin@multiquip.com

### UNITED KINGDOM

#### **Multiquip (UK) Limited Head Office**

Hanover Mill, Fitzroy Street, Tel: 0161 339 2223  
Ashton-under-Lyne, Fax: 0161 339 3226  
Lancashire OL7 0TL  
Contact: sales@multiquip.co.uk

### BRAZIL

#### **Multiquip**

Av. Evandro Lins e Silva, 840 - grupo 505 Tel: 011-55-21-3433-9055  
Barra de Tijuca - Rio de Janeiro Fax: 011-55-21-3433-9055  
Contact: cnavarro@multiquip.com.br, srentes@multiquip.com.br

© COPYRIGHT 2006, MULTIQUIP INC.

Multiquip Inc, the MQ logo are registered trademarks of Multiquip Inc. and may not be used, reproduced, or altered without written permission. All other trademarks are the property of their respective owners and used with permission.

This manual MUST accompany the equipment at all times. This manual is considered a permanent part of the equipment and should remain with the unit if resold.

The information and specifications included in this publication were in effect at the time of approval for printing. Illustrations are based on the SP2 "Street Pro" Slab Saw. Illustrations, descriptions, references and technical data contained in this manual are for guidance only and may not be considered as binding. Multiquip Inc. reserves the right to discontinue or change specifications, design or the information published in this publication at any time without notice and without incurring any obligations.

Your Local Dealer is:





## Free Manuals Download Website

<http://myh66.com>

<http://usermanuals.us>

<http://www.somanuals.com>

<http://www.4manuals.cc>

<http://www.manual-lib.com>

<http://www.404manual.com>

<http://www.luxmanual.com>

<http://aubethermostatmanual.com>

Golf course search by state

<http://golfingnear.com>

Email search by domain

<http://emailbydomain.com>

Auto manuals search

<http://auto.somanuals.com>

TV manuals search

<http://tv.somanuals.com>