

PARTS AND OPERATION MANUAL



FM9 FINISHING MACHINE

© COPYRIGHT 2001, MULTIQUIP INC.

Revision #1 (03/12/01)



MULTIQUIP INC.

18910 WILMINGTON AVE.
CARSON, CALIFORNIA 90746
310-537-3700
800-421-1244
FAX: 310-537-3927

PARTS DEPARTMENT:

800-427-1244
FAX: 800-672-7877

SERVICE DEPARTMENT:

800-478-1244
FAX: 310-537-4259

E-mail: mq@multiquip.com • www.multiquip.com

Atlanta • Boise • Dallas • Houston • Newark
Montreal, Canada • Manchester, UK
Rio De Janeiro, Brazil • Guadalajara, Mexico



WARNING



CALIFORNIA — Proposition 65 Warning

Engine exhaust and some of its constituents, and some dust created by power sanding, sawing, grinding, drilling and other construction activities contains chemicals known to the State of California to cause cancer, birth defects and other reproductive harm. Some examples of these chemicals are:

- Lead from lead-based paints.
- Crystalline silica from bricks.
- Cement and other masonry products.
- Arsenic and chromium from chemically treated lumber.

Your risk from these exposures varies, depending on how often you do this type of work. To reduce your exposure to these chemicals: **ALWAYS** work in a well ventilated area, and work with approved safety equipment, such as dust masks that are specially designed to filter out microscopic particles.

HERE'S HOW TO GET HELP

*PLEASE HAVE THE MODEL AND SERIAL NUMBER
ON-HAND WHEN CALLING*

PARTS DEPARTMENT

800-427-1244 or 310-537-3700

FAX: 800-672-7877 or 310-637-3284

SERVICE DEPARTMENT/TECHNICAL ASSISTANCE

800-478-1244 or 310-537-3700

FAX: 310- 537-4259

WARRANTY DEPARTMENT

888-661-4279, or 310-661-4279

FAX: 310- 537-1173

MAIN

800-421-1244 or 310-537-3700

FAX: 310-537-3927

Here's How to Get Help 3
Table Of Contents 4
Parts Ordering Procedures 5
Rules For Safe Operation 6

ESSICK — FM-9

Operations 7-12
Specifications 13
Explanation Of Codes In Remarks Column 14
Suggested Spare Parts 15
Cab Assembly 16-17
Automatic Clutch Assembly 18-19
Transmission Assembly 20-21
Transmission Assembly 22-23
Browning Nozzle 24-25
Finishing Nozzle 26-27

Terms and Conditions Of Sale — Parts 28

*NOTE: Specification and part number
are subject to change without notice.*

- Dealer account number
- Dealer name and address
- Shipping address (if different than billing address)
- Return fax number
- Applicable model number
- Quantity, part number and description of each part
- Specify preferred method of shipment:
 - UPS Ground
 - UPS Second Day or Third Day*
 - UPS Next Day*
 - Federal Express Priority One (please provide us with your Federal Express account number)*
 - Airborne Express*
 - Truck or parcel post

**Normally shipped the same day the order is received, if prior to 2PM west coast time.*

Earn Extra Discounts when you order by FAX!

All parts orders which include complete part numbers and are received by fax qualify for the following extra discounts:

<u>Number of line items ordered</u>	<u>Additional Discount</u>
1-9 items	3%
10+ items**	5%

Get special freight allowances when you order 10 or more line items via FAX!**

- UPS Ground Service at no charge for freight
- PS Third Day Service at one-half of actual freight cost

No other allowances on freight shipped by any other carrier.

**Common nuts, bolts and washers (all items under \$1.00 list price) do not count towards the 10+ line items.

DISCOUNTS ARE SUBJECT TO CHANGE

Fax order discount and UPS special programs revised June 1, 1995

**Extra Fax Discount
for Domestic USA
Dealers Only**

**Up to 5%
extra savings!**

**UPS
Special**
For faxed orders only

**Now! Direct TOLL-FREE access
to our Parts Department!**

Toll-free nationwide:

800-421-1244

Toll-free FAX:

800/6-PARTS-7 • 800-672-7877

RULES FOR SAFE OPERATION



■ Do not operate or service this equipment before reading the operating and maintenance instructions manual or serious injury may result.

■ Do not operate this equipment unless all guards and safety devices are attached and in place.

■ Stop the engine when leaving the equipment.

■ Block the unit when leaving or when using on a slope

■ Maintain this equipment in a safe operating condition at all times.



■ Caution must be exercised while servicing this equipment. Rotating and moving parts can cause injury if contacted.

■ Stop the engine before servicing, adding fuel and oil.



■ When towing, an adequate safety chain must be fastened to the frame.

■ Keep all inexperienced and unauthorized people away from the equipment at all times.

■ Unauthorized equipment modifications will void all warranties.

■ Check all fasteners periodically for tightness. Also check towing tongue bolt, lock nut and wheel lug nuts for wear.

■ Wear safety glasses at all times when working around machinery.



■ Stop the engine and disconnect the spark plug before allowing anybody's hands in the mixing drum.

■ Never pour or spray water over the engine or electric motor.

■ Always stand clear of dump handle when mixer is in operation. Any binding of material between the mixer blades and drum will cause drum and handle to quickly move in the discharge position.

The safety instruction decals shown must be on all Essick Mixers

CAUTION!
SHUT OFF ENGINE BEFORE
PUTTING HANDS IN MIXING DRUM

Caution Decal is P/N
FM???????

ESSICK
A MULTIQUIP COMPANY

SAFETY INSTRUCTIONS

1. Do not operate or service this machine before reading the operating and maintenance manual.
2. Keep all inexperienced and/or unauthorized people away from equipment at all times.
3. Do not operate this equipment unless all guards and safety devices are attached and in place.
4. Keep this equipment in safe operating condition at all times.
5. Caution must be exercised while servicing this equipment.
Rotating and moving parts can cause injury if contacted.
6. Stop engine and allow to cool before adding fuel or oil.
7. Stop engine when leaving equipment.
8. Block unit when parking on a slope.
9. Unauthorized equipment modifications will void all warranties.

ESSICK CONSTRUCTION PRODUCTS — A MULTIQUIP COMPANY — CARSON, CALIFORNIA

The safety instruction decal is P/N FM????????????

SAFETY

1. Do not operate or service this equipment before reading the operating and maintenance instruction manual.
2. Do not operate this equipment unless all guards and safety devices are attached and in place.
3. Stop engine when leaving equipment.
4. Block unit when parking on a slope.
5. Maintain this equipment in safe operating condition at all times.
6. Caution must be exercised while servicing this equipment. Rotating and moving parts can cause injury if contacted.
7. Stop engine before adding fuel or oil. Never spray water over the engine or electrical motor.
8. Keep all inexperienced and unauthorized people away from equipment at all times.
9. Unauthorized equipment modifications will void all warranties.
10. Run transmission in reverse gear to relieve back pressure before disconnecting gun or hoses.
11. Screen must be on hopper at all times machine is in operation.
12. Stop engine before putting hands in hopper.
13. Wear safety eye glasses at all times when working around machine or material lines.
14. Electrical operated machines refer to supplemental FM5E-I safety/operating instructions

GENERAL

The essick model FM9 plastering machine is in a class by itself. Its main functions are that of a standard finishing machine: Mainly applying acoustical ceilings, exterior dash stucco finish and inside sand finish, as well as fireproofing steel beams. Although it was not designed to be used in place of a high-volume base coat plastering machine, it may be used to apply inside brown and it is capable of applying a half-sand, half-vermiculite mix at a very practical rate, which is satisfactory for some jobs.

This machine is equipped with a transmission having 3 forward speeds plus a reverse gear and is powered by a 9.2 hp engine, which also drives a heavy-duty twin-cylinder air compressor.

Although the procedure for mixing and applying the materials varies with each material being sprayed, the following procedure applies to all the materials mentioned above.

OPERATING INSTRUCTIONS

Connect the air lines from the machine to the air control block mounted on the nozzle. One air line runs from the air compressor outlet on the machine to the inlet on the control block next to the sleeve valve. This line has air blowing out of it when the compressor is running. The other air line runs from the sleeve valve on the control block to the throttle cylinder inlet on the machine.

In operation, the compressor furnishes air to the control block. The valve located on the front of the block is for the adjustment of atomized air which is used for the spraying of material. The sleeve valve operates the throttle cylinder on the engine. When the sleeve valve is in the closed position, air pressure is applied to the cylinder and the engine will speed up to the preset governed speed. When the sleeve valve is in the open position, air pressure is released from the spring loaded throttle cylinder and the engine will return to idle speed.

Before starting engine, check oil levels in engine crankcase, transmission and compressor. Place volume control lever (transmission lever) in the position for the desired speed to be used. Turn the throttle control air valve, located on the spray gun, to the "off position.

After mixing the material, lubricate the pump and hose by pouring a few gallons of water into the hopper. Adjust the air pressure to approximately 20 lbs. and turn the throttle control air valve to "on" position.

Continue to pump out the water until it reaches the level of the pump. Then fill the hopper half full with the material to be sprayed. After the remaining water in the hose has been pumped out and material appears at the nozzle, point nozzle into hopper and make final air adjustments. With final adjustments made, turn air valve off.

CAUTION: Never turn off pump until material appears at nozzle. This may cause separation of the material, which would clog up pump and hose.

Fill hopper and carry nozzle and hose to spraying area. Turn air valve "on" and proceed to spray, working a pattern. Always overlap the spray, but never hold the gun still in an attempt to fill a void or defect.

CAUTION: Never run the pump dry, as this causes rapid pump wear or damage.

CLEANING OF MACHINE

At the end of the day, or when changing from one material to another, the machine should be washed out. It is also suggested that when pumping quick setting materials to wash out machine and hoses approximately every 4 hours.

To clean the hopper and pump parts, run transmission in reverse gear to relieve back pressure in hose, turn off engine, remove spray gun and disconnect material hose. Remove pipe plug at bottom of hopper, drain, and wash down the remaining material with water. Replace plug.

After the material has been washed out of the hopper, the hose can be cleaned by disconnecting the material hose from the machine and removing the spray gun. Roll up a wet sponge and place it into the material hose, reconnect the hose to pump fitting, fill hopper half full with water and start machine. Pump enough water through hose to push sponge through entire length of hose. After sponge is pumped out, turn off engine and remove drain plug from hopper to drain remaining water. Repeat the sponge process if necessary.

Wash out spray gun, nozzle and orifices. Hose down screens and the outside of the machine.

Note: When washing down the outside of the machine, be sure the rubber boot is in place over the transmission lever pivot. This prevents water from entering the transmission. Clean and oil all threads and joints.

MIXING AND APPLYING VARIOUS MATERIAL

EXTERIOR DASH STUCCO

In areas where this type of finish is popular, a prepared machine mix is available which requires only the addition of water. However, some contractors prefer to mix their own material. The following is considered a very satisfactory machine mix:

200 lbs. — Silica sand mo. 20

50 to 60 lbs. — Hydrated lime

100 lbs. — Plastic cement

2 to 3 lbs. — Zonolite finish aggregate

Color may be added as desired, but should be measured for uniformity.

The above materials must be thoroughly mixed and of a thin consistency, similar to a hand dash coat mix.

The surface to be sprayed should be thoroughly dry. Do not wet before applying dash coat. Use either a 1/4" or 3/8" orifice. Be sure a soft rubber stator tube is used, as soft rubber will resist abrasives. After material is mixed, proceed as explained in the operating instructions. Adjust volume at low speed and air pressure to 20-25 lbs. If a second coat is to be applied, be sure that the surface appears dry to the eye before application or it will dry spotty and show a different shade of color.

SIMULATED ACOUSTIC CEILINGS

In many areas prepared materials are available for simulated acoustic ceilings. In areas where prepared materials are not available and where a contractor prefers to mix his own, the following mix makes a satisfactory texture.

100 lbs. — Gypsum

6 cu. ft. — Vermiculite or perlite

Mix the above materials thoroughly so the aggregate does not separate when in hopper. This mix should be of heavier consistency than exterior dash, but still wet enough to pass through a 3/8" screen.

If the material aggregate is made of vermiculite, use the hard rubber stator. If the material is made of perlite, the soft rubber stator should be installed. By using a 3/8" orifice and adjusting the volume at second speed and the air pressure to 20-25 lbs. A very satisfactory pattern can be obtained.

Since the finished appearance depends on the condition of the original surface, it is suggested that any obvious defects, such as ridges or holes, should be repaired with a hand trowel also, the ceiling should BE scraped with a floor or wall scraper prior to spraying the first coat.

Care should be taken when spraying the ceilings to fill the angles well. This can be achieved by pointing the nozzle directly into the angle, thereby spraying on the wall as well as on the ceiling. The overspray on the wall can be quickly removed by using the same scraper mentioned above.

You will find that a better job can be accomplished if two coats are applied. But before applying the second coat, an inspection of the surface should be made and any defects should be repaired with a small trowel. After the inspection, the second coat can be immediately applied.

FULL ACOUSTIC CEILINGS AND FIREPROOFING UNDER STEEL DECK

There are a number of various acoustic materials available, all of which can be pumped through this machine. Some of these materials are made from vermiculite and others from perlite. Although we do not make any recommendations as to which is the better acoustic material, we do point out the fact that perlite is very abrasive and will cause rapid pump wear whereas, vermiculite will give longer pump life.

Only water needs to be added to ready-prepared materials. Some manufacturers suggest the correct amount of water in the instructions on the bag. However, if no instructions are available, the material should be mixed to a consistency thinner than that of a mixture for hand application. I.E., thin enough so that only about 10 percent of the material will be retained on a 1/2" screen when it is poured into the hopper of the machine.

After the material is mixed, proceed as explained in the operating instructions. Use either a 3/8", 7/16" or 1/2" orifice, depending on the desired texture. Use the same size hopper screen as the size of the orifice that is going to be used. Use 3/8" screen with 7/16" orifice. Use a hard rubber stator with vermiculite and a soft rubber stator with perlite. By adjusting the volume to second speed and the air pressure to 15-20 lbs, a good yardage can be obtained in small areas. However, in larger areas it may be desirable to operate at full volume.

The application of full acoustic is very similar to that of simulated acoustic, except that successive coats can be applied until proper thickness is obtained. For application procedure refer to "simulated acoustic ceilings" paragraph.

FIREPROOFING STEEL BEAMS

Consult the building specifications regarding the type of material to be used. Normally, for fireproofing metal lath wrapped steel beams, the mixture consists of one sack of either perlite or vermiculite and one sack of gypsum. These materials should be mixed to a consistency thinner than that for hand application and sprayed approximately 1" thick with an application. If a greater volume is desired, it is recommended to use a 1-1/2" hose with the machine at full volume. Note: The shorter the hose length, the greater the volume obtained.

Use the hard rubber stator with vermiculite and the soft rubber stator with perlite. It is also suggested that the largest size air jet be used in the nozzle and a 7/16" or 1/2" orifice. With the air pressure at minimum (approximately 10 PSI).

This is a very difficult operation and the operator's technique will improve with experience. The majority of experienced operators prefer to use a short nozzle for better maneuvering around steel beams.

DRYWALL MIX APPLICATION

The FM9 works quite satisfactorily for applying drywall texture mixes such as: Spatter, orange peel, fog, sand finish, as well as simulated acoustic textures. In addition, it can be used for application of mastics, sealants, emulsions, glazes, roofing finishes, sealers, water base paints, and cement paints.

BROWN COAT

As previously stated, the ESSICK MODEL FM9 plastering machine is not designed to do the work of a large base coat machine. Although it is not recommended, due to the rapid wear on the rotor and stator tube, it can apply brown coat and scratch material at a rate fast enough to be practical for some jobs.

When the machine is to be used for the application of brown or scratch material we recommend that the following suggestions be taken into consideration to aid the machine in pumping and also to obtain better results.

Install on machine, if not presently equipped, a soft rubber stator, a "hi volume" rotor and a 1-1/2" pump outlet fitting. Refer to "hi volume" instructions for changing of rotor and stator.

Use, if possible, a 400675 browning nozzle with a 5/8" orifice for outside brown and scratch and a 1/2" orifice for inside brown. The length of 1-1/2" hose should not exceed 100 ft. With hoses and nozzle attached adjust the air pressure to approximately 20 p.s.i. and set machine at full volume.

The following is a satisfactory brown coat mix:

- 1-1/2 cu. ft. — Vermiculite
- 1-1/2 cu. ft. — Sand
- 1 Sack gypsum

Note: The best results are obtained by not using over 50 percent sand aggregate.

The mixing procedure should be as follows: Put approximately 10 gallons of water in the mixer and add 1-1/2 cu. ft. of vermiculite. This allows the vermiculite to absorb sufficient water. Add one sack of gypsum (machine application type) and shovel in 1-1/2 cu. ft. of sand (approximately eleven no. 2 shovels). additional water should be added at this time.

It is difficult to predetermine the amount of water, as there are several variations possible. The amount of water is critical and experience will allow the operator to determine the correct amount.

MAINTENANCE OF MACHINE

ENGINE

Refer to engine manufacturer's maintenance manual for lubrication, adjustments and maintenance. Under extremely dusty working conditions special attention should be given to air and oil filters and crankcase breather.

TRANSMISSION

The transmission has 3 speeds forward plus one reverse and is totally enclosed with all gears running in oil. Shifting to the forward and reverse speeds is similar to that of an automobile. See diagram.

The reverse gear can be used to relieve the back pressure whenever the hose or pump becomes clogged.

Note: Gears should only be shifted when engine is idling.

If at any time it is difficult to shift gears, it is because the gears are meeting at flat points and realignment can be fired by speeding up the engine and returning it to idle.

The oil level plug, filter plug and drain plug are located on the side of the transmission. Use SAE 90 oil and check monthly.

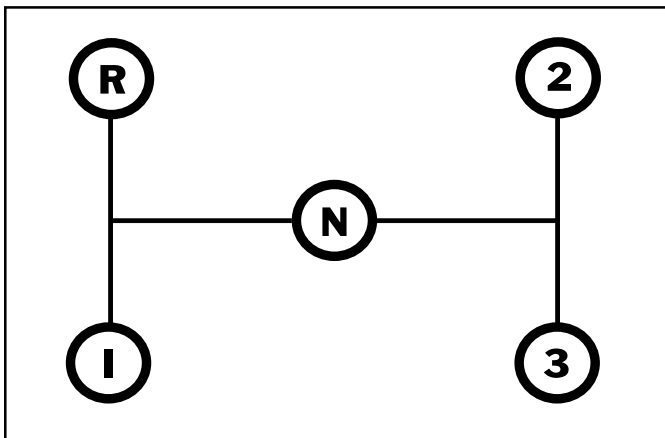

COMPRESSOR

Refer to compressor manufacturer's maintenance manual for lubrication, adjustments and maintenance.

CLUTCH

The clutch is a centrifugal type clutch and is fully automatic. It is set at the factory to start engaging at 1600 r.p.m. and is fully engaged at 1700 r.p.m. It is ineffective at engine idle speed of 1550 r.p.m. Do not idle engine for prolonged periods of time, as it may overheat. Also, be sure engine does not idle at a higher speed, as this will wear the automatic, clutch.

ROTOR AND STATOR

Both the rotor and stator parts are subjected to wear. It is difficult to say just how long a stator or rotor will last, as this depends on various conditions under which the machine is operated. The abrasive type materials will cause the most wear. Therefore, to prolong the life of the pump, the stator tubes are made of two types of rubber: A soft rubber stator for use with abrasive aggregates, such as sand or perlite and a hard rubber stator for use with non-abrasive aggregates. It is not necessary to replace both the rotor and stator at the same time, as a rotor will normally last through approximately 3 stator tubes.

To prevent excessive wear of the pump, the following precautions should be taken.

1. Do not use long hoses. Use as short a hose as feasible.
2. Avoid the use of extremely stiff materials. They reduce the volume.
3. Ensure sufficient "fat" for lubrication by not having the mixes too "lean".
4. Never allow the hopper to run out of material with the pump operating.
5. Turn stator tube end for end about twice during its life.

ROTOR AND INSTALLATION

Lubricate the inside of the stator tube and the rotor with a liquid detergent or soap (oil will deteriorate the rubber). This will make the rotor slide into the stator tube with very little pressure.

The fit between the stator and rotor has to be very tight and may be difficult to achieve when these parts are assembled without lubrication.

It is normally difficult to operate the machine in second or third gear with the "hi volume" pump until approximately one days run of material has passed through the newly installed pump. This is due to the fact that the rotor must smooth itself out. The rotor and stator have to be very tight in the machine, as well as the clamp around the stator tube.

Upon installing the soft rubber pump you will find that the fit between the rotor and stator is not quite as tight as on the hard rubber pump. With lubricant in the pump (water or material) you should be able to run the machine in second or third gear from the beginning.

PACKING GLAND ADJUSTMENT

Near the transmission and welded to the bottom side of the hopper is a packing box with special rubberized packing. A split packing gland is located on the outside of the hopper. By tightening this gland the packing in the box is compressed to keep moisture from leaking out around the shaft.

It is necessary on new units for the packing to be compressed several times before it sets properly around the drive shaft. This must be done when the unit is put into operation for the first time as well as each time a complete new set of packings are installed. The following is a suggested procedure of maintenance:

BREAK-IN

Tighten evenly (approximately 100 in. pounds torque) the two nuts located on packing gland. These nuts should be tight but not so tight as to seize or bind the shaft. Do this twice a day for the first 5 days of running time.

MAINTAIN

The packing should be lubricated daily with two shots of a good grade of waterproof grease. The grease fitting located on the drive line between the packing gland and the transmission is provided for this purpose. Daily lubrication will prolong the life of the packing.

After break-in period, tighten nuts at least once a week unless there are signs of leakage around shaft, (periodic checks for this is suggested) then tighten at once.

When all take-up on gland has been used, loosen packing gland, coat new packing ring and drive shaft with a generous amount of a good grade of waterproof grease, insert packing, and continue to maintain as noted above.

NEW PACKING

At such a time when old packing is to be completely replaced, coat shaft and packing generously with a good grade of waterproof grease and insert packing rings. Tighten packing gland nuts to approximately 150 in. pounds torque to seat packing, then back off nuts so drive shaft is not bound, but not less than 100 in. pounds torque on the nuts. Then follow procedure outlined above.

DRIVE SHAFT ALIGNMENT

If at any time the transmission is disassembled from its mounting base then caution should be taken that on reassembly the drive shaft is in alignment with transmission. To check alignment let drive shaft with packing and packing gland installed, rest free. Place transmission onto base. If mounting holes in drive shaft and transmission do not line up without any pressure or force being applied then it is necessary to place shims beneath transmission until required height is obtained.

REPLACING AND ADJUSTING THE BELTS

For adjusting the belts on the countershaft pulleys the unit is equipped with belt tighteners. The belts can be tightened by turning the set screws on the counter shaft risers. When adjusting the belts, both sides must be equally adjusted. The belts should be fairly tight.

To adjust the compressor belts, loosen the compressor mounting bolts and slide the compressor until belt is tight. Note: This belt should not be as tight as the ones on the countershaft.

To replace the countershaft belts, loosen the set screws in the bearing collars and slide the shaft out until the belts can be removed. However, it may be necessary (due to the bearings freezing to the shaft) to remove the two bolts on the bearing bracket at each end and slide out the shaft and bearings. When installing a new belt, readjustment will be necessary. After a few hours of operation check the adjustment of the new belt as there is generally a certain amount of initial stretch.

COUNTERSHAFT BEARINGS

The countershaft supports are equipped with double-sealed ball bearings. These bearings are pre-lubricated at the factory and require no additional lubrication.

SLOW-DOWN DEVICE

A slow-down device is located on the countershaft riser. This device is actuated by air, which is controlled by the air valve on the spray gun. When the air valve is "on," the shaft of the slow-down device is extended and thereby allows engine to reach the set governed speed. When the valve is turned "off," the shaft retracts and the engine idles at preset speed.

The governed engine speed is set at the factory at 3000 r.p.m. less volume can be attained by readjusting the governed speed. However, the speed should not be adjusted to less than 2000 r.p.m. (about 5 notches on the throttle control lever).

AIR SYSTEM

An air pulsation chamber is located on the left side of the unit. The air is supplied to the chamber from the compressor. The chamber is equipped with an air pressure gauge and a safety valve. The safety valve is set at the factory at approximately 60 lbs.

HI-VOLUME PUMP

An outstanding feature of the ESSICK MODEL FM9 finishing machine is that two different size pumps may be used, which tremendously increases its versatility. A more powerful engine and transmission are designed into this unit and a hi-volume pump is furnished as standard. A lo-volume pump is offered as an optional item. This pump consists of two parts: A smaller rotor and a smaller stator, which, in turn, may be used when a lower volume of material is required.

The installation of this pump is very easy because all parts are interchangeable. It is only necessary to remove the rotor pin, which fastens the rotor to the connecting rod located at the bottom of the material hopper, and then thread out the stator tube with the rotor encased, and install the lo-volume pump in the same manner. The installation is made easier by threading the rotor into the stator tube prior to starting assembly.

Fireproofing is one application where the hi-volume pump is of great advantage. Competitive machines available for fireproofing are twice the price of this versatile machine. Another purpose for which the machine can be employed is the application of browncoat. The hi-volume pump will apply approximately 14 sacks of gypsum hardwall material per hour.

To obtain maximum volume we suggest not to use more than 75 feet of 1-1/2" hose (actual pump volume is slightly under 2 c.f.m.).

PARTS LIST AND OPERATING INSTRUCTIONS

MODEL FM5E-I

THIS IS A SUPPLEMENT TO THE FM9 OPERATING AND MAINTENANCE INSTRUCTIONS

READ BOTH SETS OF INSTRUCTIONS BEFORE OPERATING THIS MACHINE

CAUTION: This machine uses high voltages that can be dangerous and cause injury. Only qualified electricians should install power supplies or service the electrical components. Power supply must be in accordance with local electrical codes and of adequate size to avoid the possibility of overheating the motors due to low voltage. Supply line must be at least No. 8 gauge wire and capable of delivering 35 amperes at 240 volts to control panel of machine. When cleaning, never spray water on the electric motor. Do not operate machine in standing water.

COMPRESSOR MOTOR - The 1H.P. compressor motor is operated by a manual ON-OFF switch on the control panel.

PUMP MOTOR - The 5 H.P. pump motor is operated by a magnetic starter switch. The magnetic starter is equipped with an overload heater for motor protection.

A 240-volt system of switches and relays is used to control the magnetic starter. It is protected by a circuit breaker with a reset button in the door of the starter box

The air control sleeve valve on the nozzle is the master link in the system. Connect the air line from the air compressor outlet to the inlet on the control block next to the sleeve valve. This line has air blowing out of it when the compressor is running. The other air line runs from the sleeve valve to the pressure switch inlet on the machine.

In operation, the sleeve valve operates the pressure switch. When the sleeve valve is in the CLOSED position, air pressure is applied to the pressure switch. This closes the switch and starts the pump motor. When the sleeve valve is in the OPEN position, air pressure is released from the pressure switch. This opens the switch and stops the pump motor. The pump cannot be operated without the air controls and air lines. This is a safety feature for the gun operator and must not be bypassed in any way.

An AUTO-OFF-HAND switch is located on the door of the starter box. Turning the switch to OFF overrides the sleeve valve control and stops the pump. Turning the switch back to AUTO or HAND returns control to the sleeve valve. This switch must never be wired to turn the pump on without air pressure from the sleeve valve to the pressure switch.

REF	DESCRIPTION	SERIAL NO	PART NO.	QTY.
1	PUMP - 5 H.P.		939303	1
2	COMPRESSOR MOTOR - 1 1/2 H.P.		939069	1
3	COMPRESSOR AND MOTOR SUPPORT		402721	1
4	AIR HOSE - COUPLING TO PRESSURE SWITCH		401511	1
5	CAB ASSEMBLY		402717	1
6	PULLY - PUMP MOTOR		901268	1
7	PULLEY BUSHINH - PUMP MOTOR		901455	1
8	PULLEY - COMPRESSOR MOTOR		901109	1
9	PRESSURE SWITCH		940014	1
10	FLANGED CONNECTOR INLET		940054	1
11	CONNECTOR BODY		940053	1
12	MAGNETIC STARTER WITHOUT OVERLOAD HEATER		940641	1
13	CONTACTOR SWITCH		940008	1
14	OVERLOAD HEATER		940241	1

FM-9 — SPECIFICATIONS

<u>MODEL</u>	<u>U.S.(inch)</u>	<u>METRIC</u>
CAPACITY	???	????
BAG CAPACITY	???	????
WEIGHT (approx.)	???	????
L X W X H	???	????
LENGTH W/TOW BAR	???	????
HEIGHT W/DUMP HANDLE	???	????
DISCHARGE HEIGHT	???	????
DRIVE	???	????
DUMP ACTION	???	????

EXPLANATION OF CODE IN REMARKS COLUMN

How to read the marks and remarks used in this parts book.

Section 1: Items Found In the “Remarks” Column

Serial Numbers-Where indicated, this indicates a serial number range (inclusive) where a particular part is used.

Model Number-Where indicated, this shows that the corresponding part is utilized only with this specific model number or model number variant.

Section 2: Items Found In the “Remarks” Column

Serial Numbers-Where indicated, this indicates a serial number range (inclusive) where a particular part is used.

Model Number-Where indicated, this shows that the corresponding part is utilized only with this specific model number or model number variant.

Section 3: Items Found In the “Items Number” Column

All parts with same symbol in the number column, *, #, +, %, or ■, belong to the same assembly or kit.

Note: If more than one of the same reference number is listed, the last one listed indicates newest (or latest) part available.

NOTE

If more than one of the same reference number is listed, the last one listed indicates newest (or latest) part available.

NOTE

The contents of this catalog are subject to change without notice.

FM-9 — SUGGESTED SPARE PARTS

FM-9 — 1 to 3 Units

Qty.	P/N	Description
?	?????EM50	???????????

FM-9 — 1 to 5 Units

Qty.	P/N	Description
?	?????EM50	???????????

NOTE

Part numbers on this Suggested Spare Parts List may supercede/replace the P/N shown in the text pages of this book.

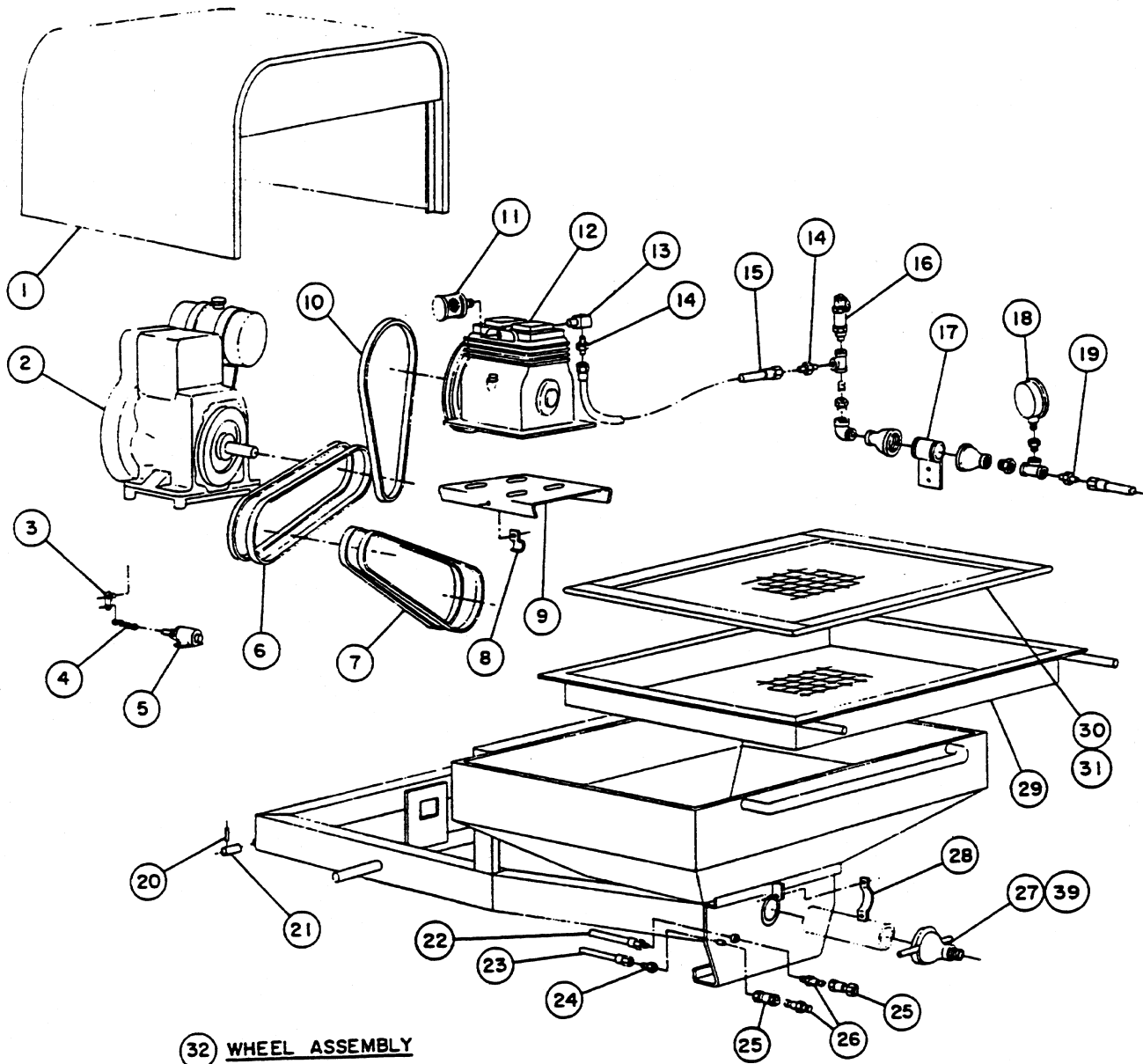

32 WHEEL ASSEMBLY

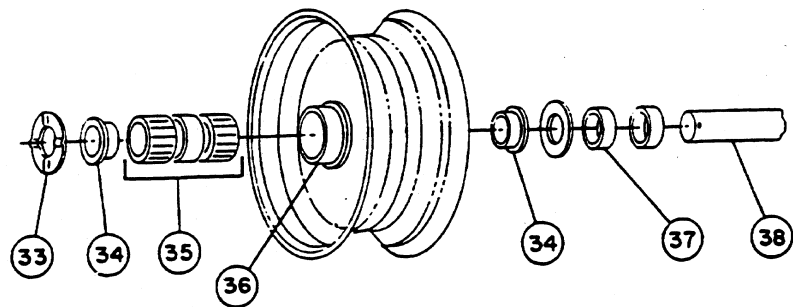

<u>NO</u>	<u>PART NO</u>	<u>PART NAME</u>	<u>QTY</u>	<u>REMARKS</u>
1	402635	CAB ASSEMBLY	1	62330527
2	937175	ENGINE	1	62330527
3	400538	THROTTLE LEVER	1	62330527
4	010036	THROTTLE CHAIN	1	62330527
5	400539	AIR CYLINDER	1	62330527
6	900144	V-BELT-ENG. TO COUNTERSHAFT	2	62330527
7	900148	V-BELT-COUNTERSHAFT TO TRANS.	2	62330527
8	928055	CLIP	1	62330527
9	400006	COMPRESSOR BASE	1	62330527
10	900296	V-BELT-COMPRESSOR TO ENG.	1	62330527
11	958019	AIR FILTER	1	62330527-960101
11	960101	AIR FILTER		
12	958008	COMPRESSOR	1	62330527
12				
13	911253	MALE ELBOW	1	62330527
14	911255	ADAPTER	2	62330527
15	400530	AIR LINE	1	62330527
16	913038	SAFETY VALVE	1	62339527
17	400496	TANK SUPPORT	1	62339527
18	920010	AIR GAUGE	1	62339527
19	911242	ADAPTER	1	62339527
20	925003	ROLL PIN	2	62339527
21	400506	HINGE PIN	2	62339527
22	400011	AIR HOSE-TO TANK	1	62330527
23	400012	AIR HOSE-TO CYLINDER	1	62330527
24	911243	ADAPTER	1	62330527
25	947035	DISCONNECT BODY	2	62330527
26	947032	DISCONNECT PLUG	2	62330527
27	400484	PUMP OUTLET FITTING-1"-OPTIONAL	1	62330527
28	400558	STATOR TUBE CLAMP	2	62330527
29	400010	MAIN SCREEN - 2X2	1	62330527
30	400009	SCREEN - 3X3	1	62330527
31	400008	SCREEN -4X4	1	62330527
32	200793	WHEEL ASSEMBLY W/TIRE & TUBE	2	62330527
33	200017	AXLE WASHER	2	62330527
34	922003	BEARING RETAINER	4	62330527
35	201337	BEARING	2	62330527
36	941043	WHEEL LESS TIRE & TUBE	2	62330527
37	941077	WHEEL SPACER	4	62330527
38	400015	AXLE	2	62330527
39	400483	PUMP OUTLET FITTING-1 1/2"-STANDARD.	1	62330527

FM-9 — AUTOMATIC CLUTCH ASSEMBLY

50 CLUTCH ASSEMBLY

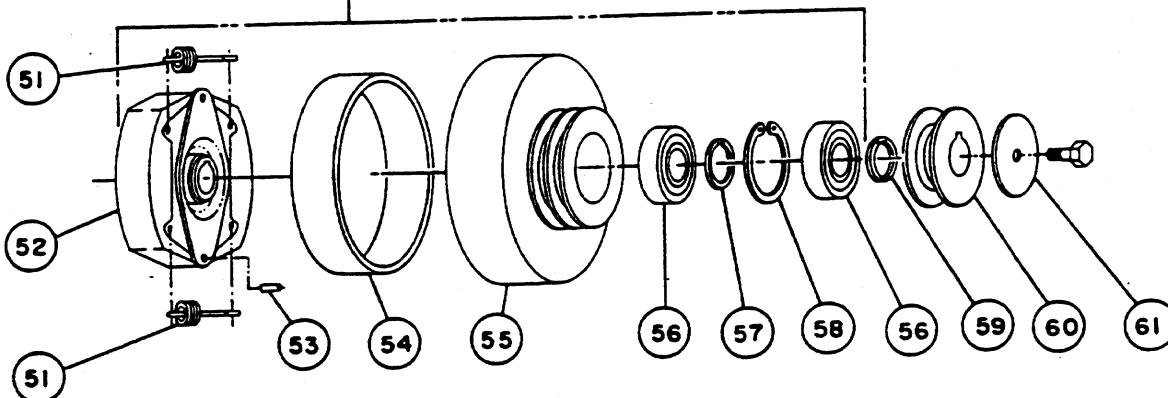

DRIVE SHAFT DETAIL

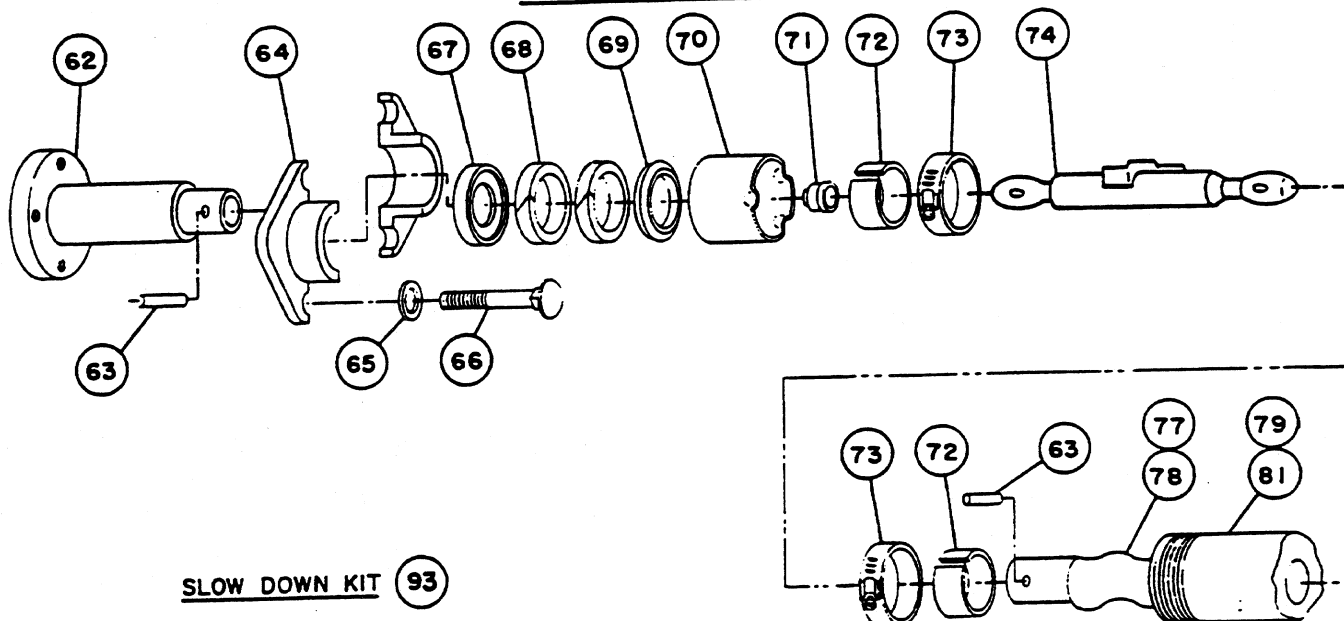

SLOW DOWN KIT 93

COUNTERSHAFT DETAIL

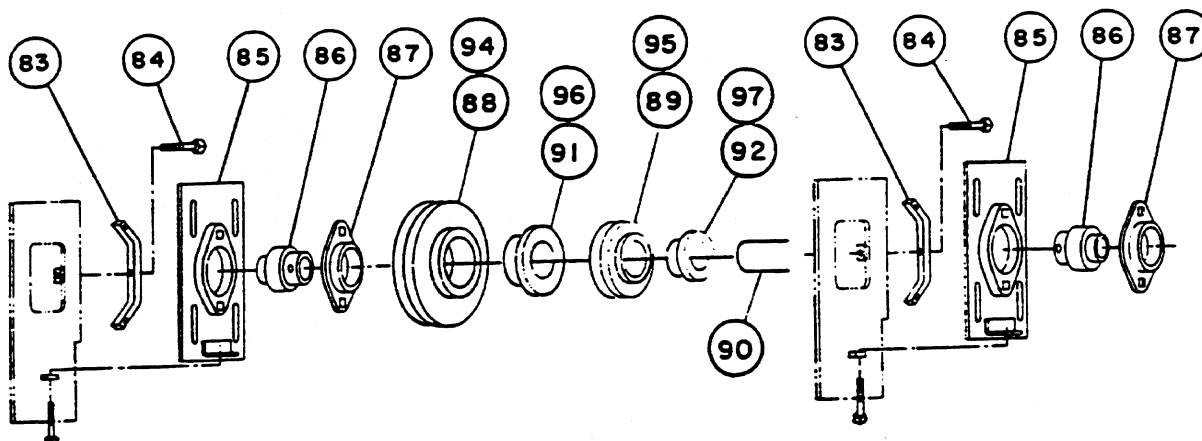

FM-9 — AUTOMATIC CLUTCH ASSEMBLY

<u>NO</u>	<u>PART NO.</u>	<u>PART NAME</u>	<u>QTY.</u>	<u>REMARKS</u>
50	934014	AUTOMATIC CLUTCH ASSEMBLY	1	62330527
51	918046	SPRING	2	62330527
52	934182	ROTOR PLATE ASSEMBLY	1	62330527
53	925080	PIN	2	62330527
54	803378	LINING W/RIVETS	1	62330527
55	934180	CLUTCH HOUSING	1	62330527
56	902083	BEARING	2	62330527
57	934181	BEARING SPACER	1	62330527
58	926080	SNAP RING	1	62330527
59	960004	PULLEY SPACER - KEY RING	1	62330527
60	400709	PULLEY	1	62330527
61	300057	RETAINING WASHER	1	62330527
62	400931	OUTPUT SHAFT ASSY.-INC. ITEM 71	1	62330527
63	401982	DRIVE PIN	2	62330527
64	400511	PACKING GLAND HALF	2	62330527
65	914002	BIBB WASHER	2	62330527
66	966209	PACKING GLAND BOLT	2	62330527
67	914201	SEAL-DISCONTINUED-USE ITEM 68	1	62330527
68	200301	PACKING RING	3	62330527
69	200303	PACKING RING	1	62330527
70	400509	PACKING BOX	1	62330527
71	400532	INSERT - DRIVE END	1	62330527
72	400533	COLLAR - DRIVE PIN	2	62330527
73	928005	CLAMP - DRIVE PIN	2	62330527
74	400016	DRIVE SHAFT AND AGITATOR	1	62330527
77	400542	LO-VOLUME ROTOR-15 1/8" LONG OPDTIONAL	1	62330527
78	400545	HI-VOLUME ROTOR-16 3/4" LONG STANDARD	1	62330527
79	400543	LO-VOLUME SOFT STATOR ORANGE OPTIONAL	1	62330527
80	400549	LO-VOLUME HARD STATOR-BLACK-OPTIONAL 12 3/8" LONG		62330527
81	400546	HI-VOLUME SOFT STATOR-ORANGE-STD. 14 1/4" LONG	1	62330527
81				
82	400550	HI-VOLUME SOFT STATOR-BLACK-STD. 14 1/4" LONG		62330527
83	400501	TIGHTENER BRACKET	2	62330527
84	961007	ADJUSTING SCREW	4	62330527
85	400535	ADJUSTING BRACKET	2	62330527
86	902073	BEARING WITH COLLAR	2	62330527
87	905003	BEARING PLATE	2	62330527
88	901282	PULLEY LESS BUSHING	1	62330527
89	901292	PULLEY LESS BUSHING	1	62330527
90	400497	COUNTER SHAFT	1	62330527
91	901003	BUSHING FOR ITEM 88	1	62330527
92	901016	BUSHING FOR ITEM 89	1	62330527
		<u>FOR SLOW-DOWN KIT-USE THE FOLLOWING:</u>		
93	400494	SLOW-DOWN KIT-INCLUDES 94, 95, 96, 97	1	62330527
94	901492	PULLEY LESS BUSHING	1	62330527
95	901491	PULLEY LESS BUSHING	1	62330527
96	901493	BUSHING-FOR ITEM 95	1	62330527
97	901519	BUSHING-FOR ITEM 94	1	62330527

FM-9 — TRANSMISSION ASSEMBLY

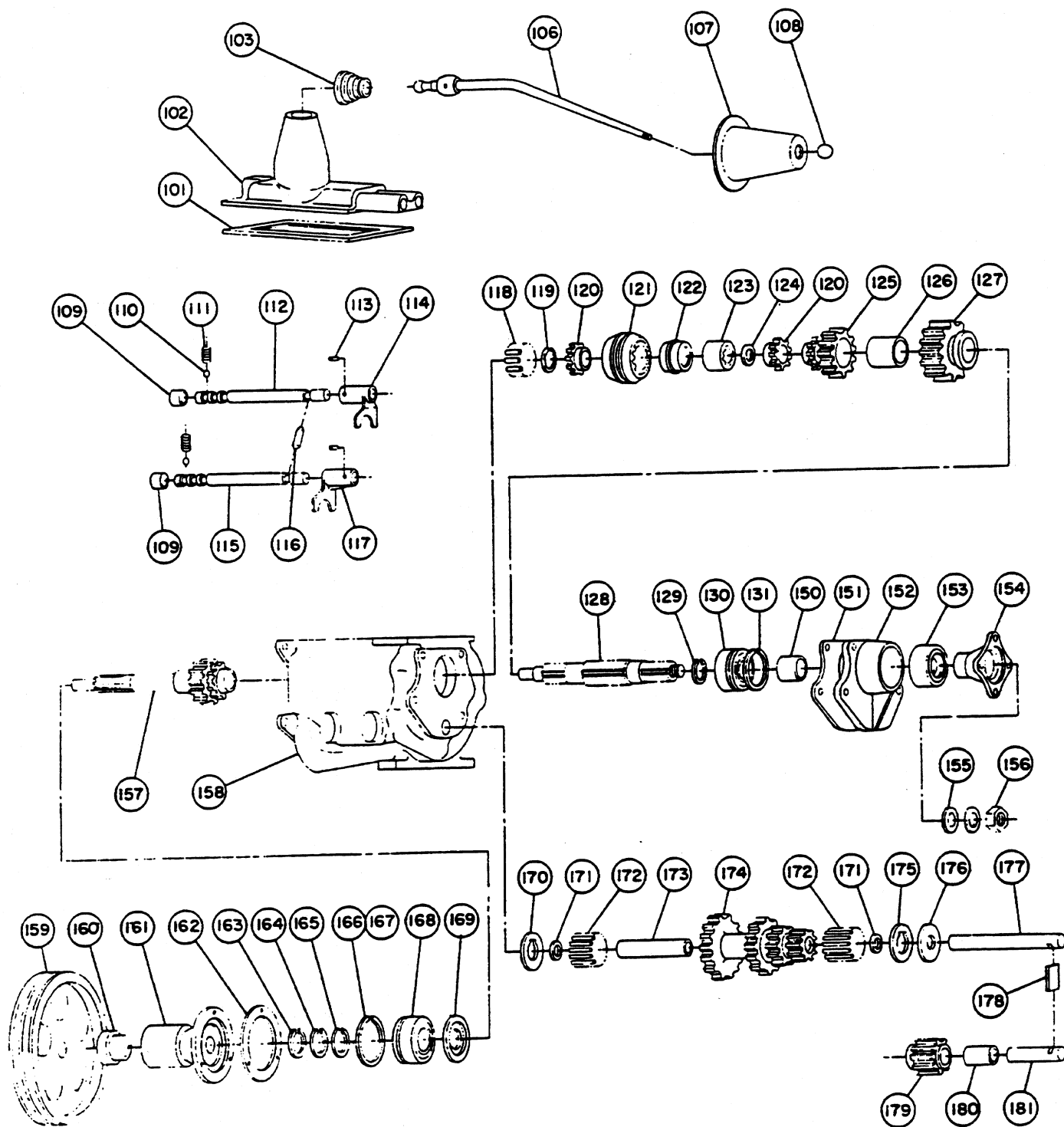

FM-9 — TRANSMISSION ASSEMBLY

<u>NO.</u>	<u>PART NO.</u>	<u>PART NAME</u>	<u>QTY</u>	<u>REMARKS</u>
100	400537	TRANSMISSION ASSEMBLY	1	62330527
101	914168	GASKET- CONTROL HOUSING	1	62330527
102	931166	CONTROL HOUSING	1	62330527
103	918048	CONTROL LEVER SPRING	1	62330527
106	402938	CONTROL LEVER WITH BALL AND PIN	1	62330527
107	970001	RUBBER BOOT	1	62330527
108	960002	LEVER KNOB	1	62330527
109	931168	SHIFT RAIL CAP	2	62330527
110	931175	STEEL BALL	2	62330527
111	918047	POPPET SPRING	2	62330527
112	931170	LOW-REVERSE SHIFT RAIL	1	62330527
113	931173	FORK PIN	2	62330527
114	931172	LOW-REVERSE SHIFT FORK	1	62330527
115	931169	HIGH-INTERMEDIATE SHIFT RAIL	1	62330527
116	931174	INTERLOCK PLUNGER	1	62330527
117	931171	HIGH-INTERMEDIATE SHIFT FORK	1	62330527
118	931165	PILOT BEARING ROLLER	13	62330527
119	SNAP RING - CLUTCH HUB*			62330527
120	BLOCKING RING*		62330527	
121	931157	SECOND & DIRECT CLUTCH ASSY *121	1	62330527
	INCLUDES 119, 120, 122, 123, AND 124			
122	SHIFTING PLATE*		62330527	
123	INTERMEDIATE & HIGH CLUTCH HUB*			62330527
124	SPRING*		62330527	
125	932053	SECOND SPEED GEAR	1	62330527
126	931177	GEAR BUSHING	1	62330527
127	932054	LOW-REVERSE GEAR	1	62330527
128	955050	MAINSHAFT	1	62330527
129	926082	SNAP-RING MAINSHAFT	1	62330527
130	902010	BEARING	1	62330527
131	926083	BEARING SNAP RING	1	62330527

FM-9 — TRANSMISSION ASSEMBLY

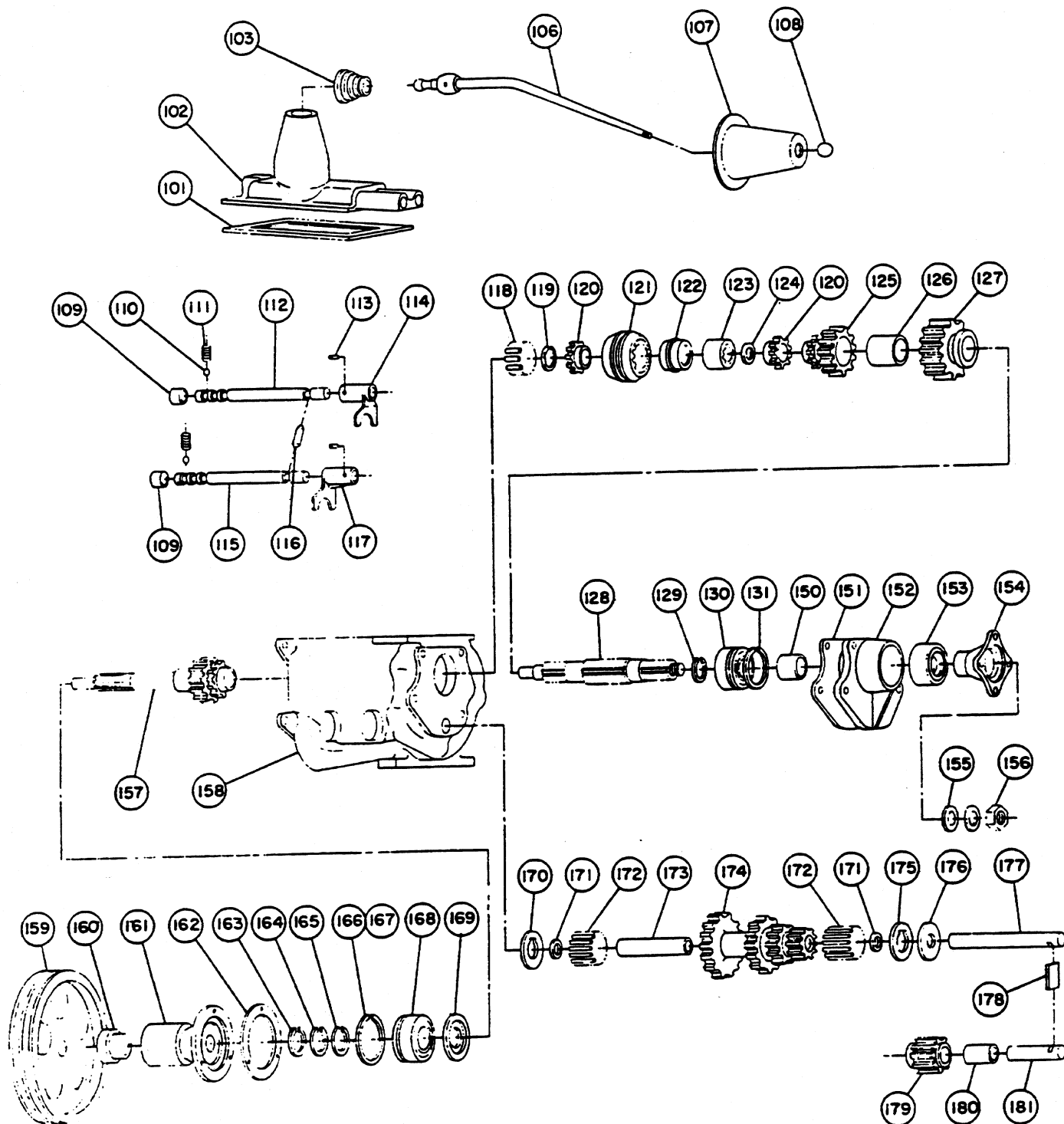

FM-9 — TRANSMISSION ASSEMBLY

<u>NO.</u>	<u>PART NO.</u>	<u>PART NAME</u>	<u>QTY.</u>	<u>REMARKS</u>
150	931158	MAINSHAFT SPACER	1	62330527
151	914166	GASKET BEARING RETAINER	1	62330527
152	922019	REAR BEARING RETAINER	1	62330527
153	914169	OIL SEAL	1	62330527
154	401900	COMPANION FLANGE	1	62330527
155	931159	MAINSHAFT WASHER	1	62330527
156	931189	MAINSHAFT NUT	1	62330527
157	932052	MAIN DRIVE GEAR	1	62330527
158	931155	TRANSMISSION CASE	1	62330527
159	400500	PULLEY	1	62330527
160	902072	BEARING W/COLLAR	1	62330527
161	400495	SHAFT HOUSING	1	62330527
162	914167	GASKET- BEARING RETAINER	1	62330527
163	926086	SNAP RING	1	62330527
164	926087	SNAP RING	1	62330527
165	926088	SNAP RING	1	62330527
166	926084	SNAP RING	1	62330527
167	926085	SNAP RING	1	62330527
168	902050	BEARING	1	62330527
169	931181	OIL BAFFLE	1	62330527
170	931162	THRUSTWASHER	1	62330527
171	931161	BEARING SPACER	2	62330527
172	931178	BEARING ROLLER	40	62330527
173	931160	BEARING SPACER	1	62330527
174	932056	COUNTERSHAFT GEAR	1	62330527
175	931163	THRUSTWASHER - C SHAFT	1	62330527
176	931164	THRUSTWASHER	1	62330527
177	955051	COUNTERSHAFT	1	62330527
178	931179	LOCK PLATE	1	62330527
179	932055	REVERSE IDLER GEAR	1	62330527
180	931180	BUSHING - IDLER GEAR	1	62330527
181	955052	REVERSE IDLER SHAFT	1	62330527

FM-9 — BROWNING NOZZLE

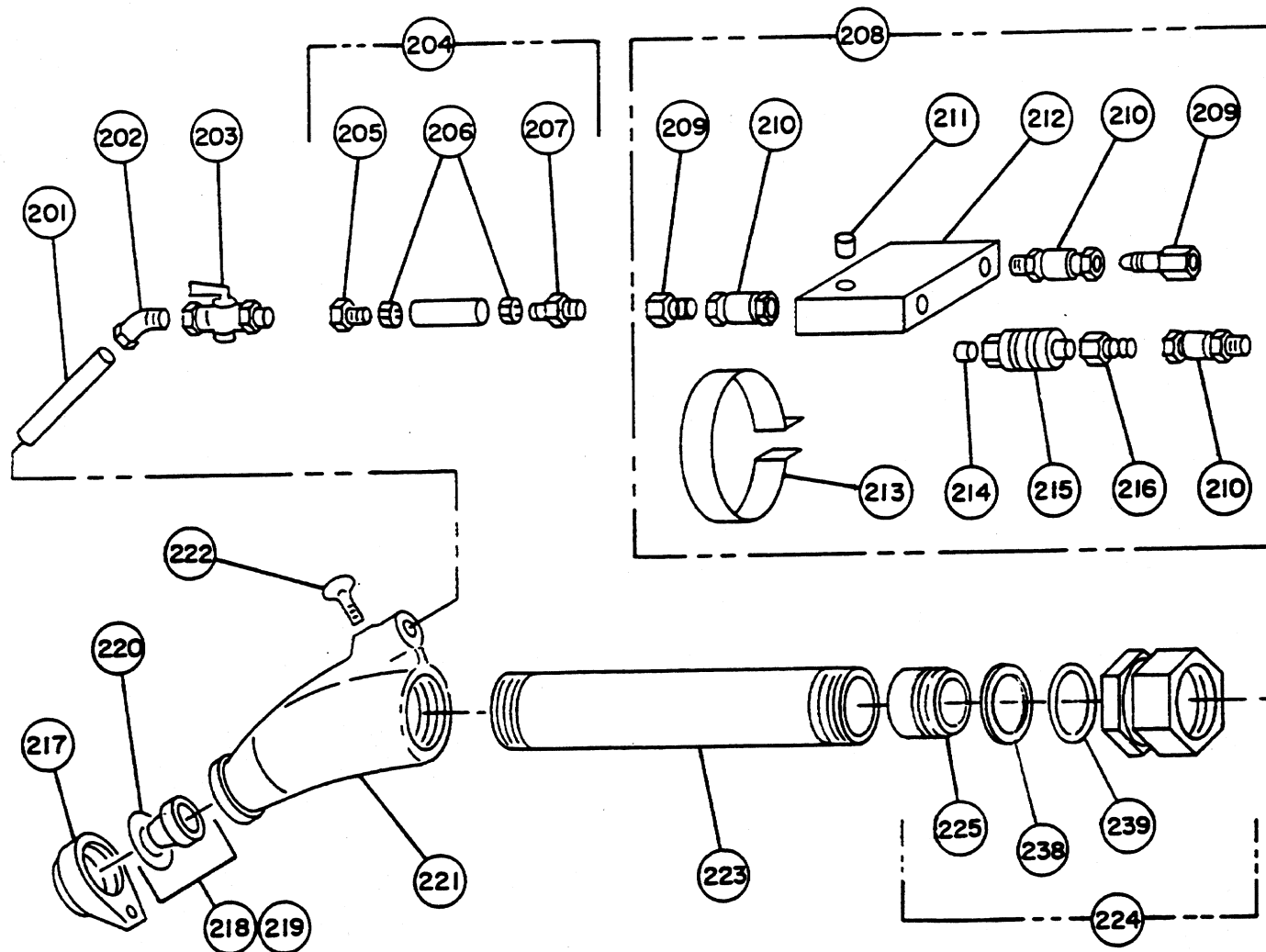

OPTIONAL PARTS FOR BROWNING NOZZLE

ORIFICE

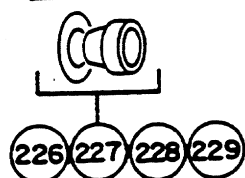

NOZZLE SHIELD

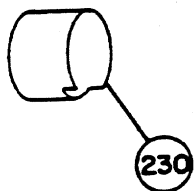

12 INCH NOZZLE EXTENSION

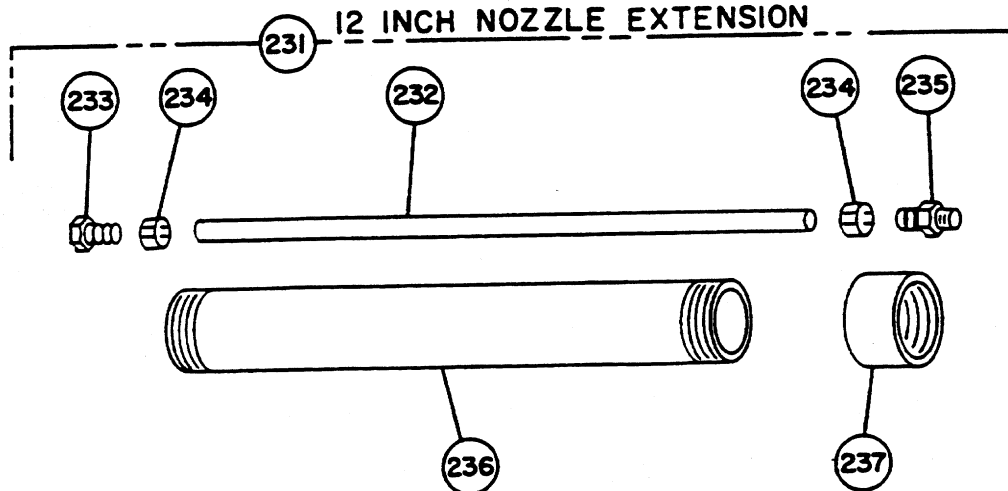

<u>NO.</u>	<u>PART NO.</u>	<u>PART NAME</u>	<u>QTY.</u>	<u>REMARKS</u>
		<u>FOR 12" BROWNING NOZZLE USE FOLLOWING</u>		
200		<u>12" BROWNING NOZZLE COMPLETE, INCLUDES</u>		
	400675	ITEM 201 THRU ITEM 225	1	62330527
201	400671	AIR JET	1	62330527
202	402704	ELBOW	1	62330527
203	913031	AIR VALVE	1	62330527
204	400560	AIR LINE ASSEMBLY	1	62330527
205	947073	FEMALE SWIVEL INSERT - 1/4"	1	62330527
206	928043	HOSE CLAMP - 1/4"	2	62330527
207	947041	MALE BARBED INSERT - 1/4"	1	62330527
208	400935	AIR CONTROL BLOCK ASSEMBLY	1	62330527
209	947030	DISCONNECT PLUG - 1/4"	2	62330527
210	947029	DISCONNECT BODY - 1/4"	3	62330527
211	911225	AIR BLOCK PLUG	1	62330527
212	400519	AIR CONTROL BLOVK	1	62330527
213	400572	CLAMP	1	62330527
214	912001	NIPPLE	1	62330527
215	913004	SLIDE VALVE	1	62330527
216	947028	DISCONNECT PLUG - 1/8"	1	62330527
217	400668	NOZZLE CAP	1	62330527
218	400689	ORIFICE - 5/8"	1	62330527
219	400690	ORIFICE - 3/4"	1	62330527
220	300575	SHIM WASHER	A/R	62330527
221	400670	GUN BODY	1	62330527
222	922027	THUMB SCREW	1	62330527
223	400672	NOZZLE EXTENTION PIPE	1	62330527
224	401036	SWIVEL ASSEMBLY - 1 1/4" X 1 1/2"	1	62330527
225	911328	SWIVEL BUSHING	1	62330527
238	402707	WASHER	1	62330527
239	915092	"O" -RING	1	62330527
		<u>OPTIONAL PARTS USED WITH BROWNIN</u>		
		<u>NOZZLE ABOVE</u>		
226	400685	ORIFICE - 1/4"	1	62330527
227	400686	ORIFICE - 3/8"	1	62330527
228	400687	ORIFICE - 1/2"	1	62330527
229	400688	ORIFICE - 9/16"	1	62330527
230	400691	NOZZLE SHIELD	1	62330527
231	400681	12" NOZZLE EXTENSION KIT	1	62330527
232	400680	HOSE ASSEMBLY COMPLETE	1	62330527
233	947073	FEMALE SWIVEL INSERT - 1/4"	1	62330527
234	928043	HOSE CLAMP - 1/4"	2	62330527
235	947041	MALE BARBED INSERT - 1/4"	1	62330527
236	400673	EXTENSION PIPE	1	62330527
237	911363	PIPE COUPLING	1	62330527

FM-9 — FINISHING NOZZLE

250 36 INCH FINISHING NOZZLE

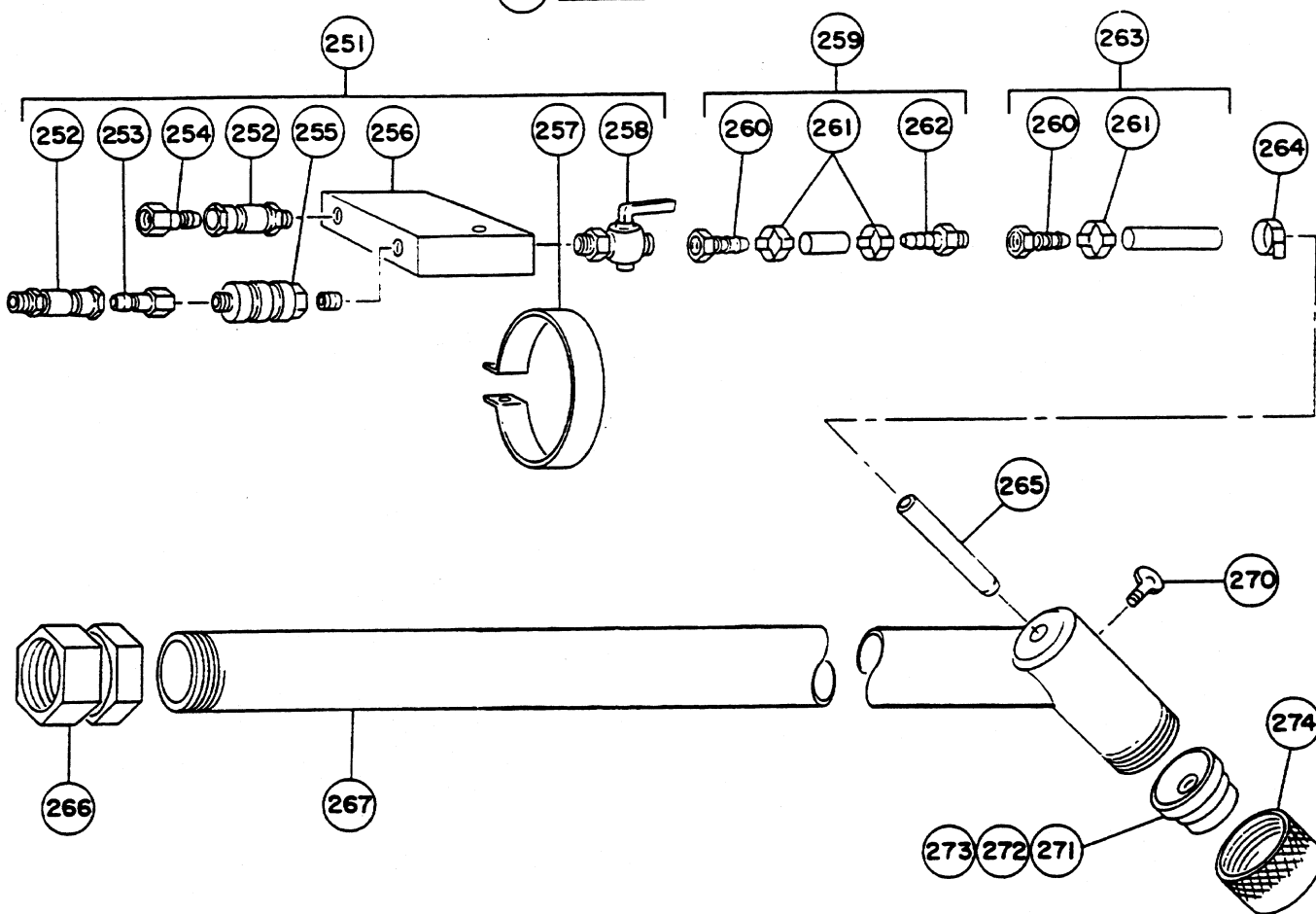

OPTIONAL PARTS FOR FINISHING NOZZLE

278 24 INCH NOZZLE EXTENSION ASSEMBLY

ORIFICE

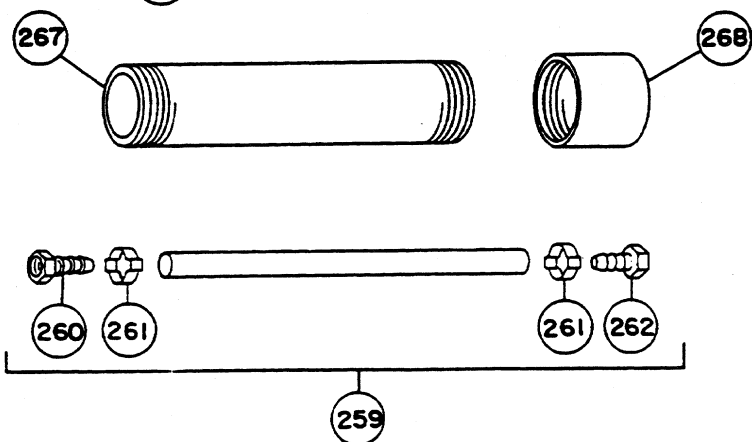

<u>NO.</u>	<u>PART NO.</u>	<u>PART NAME</u>	<u>QTY</u>	<u>REMARKS</u>
<u>FOR FINISHING NOZZLE USE THE FOLLOWING:</u>				
250		36" FINISHING NOZZLE COMPLETE, INCLUDES		
	400488	ITEMS 251 THRU 274	1	62330527
251	400923	AIR CONTROL BLOCK ASSEMBLY	1	62330527
252	947029	DISCONNECT BODY	2	62330527
253	947028	DISCONNECT PLUG	1	62330527
254	947030	DISCONNECT PLUG	1	62330527
255	913004	SLEEVE VALVE	1	62330527
256	400519	AIR CONTROL BLOCK	1	62330527
257	400540	CLAMP	1	62330527
258	913054	VALVE	1	62330527
259	400490	HOSE ASSEMBLY COMPLETE	1	62330527
260	947073	FEMALE SWIVEL INSERT - 1/4"	2	62330527
261	928043	HOSE CLAMP - 1/4"	3	62330527
262	947041	MALE BARBED INSERT - 1/4"	1	62330527
263	400489	HOSE ASSEMBLY COMPLETE	1	62330527
264	928041	CLAMP	1	62330527
265	400534	AIR JET	1	62330527
266	400541	NOZZLE SWIVEL	1	62330527
267	400523	EXTENSION TUBE	1	62330527
268	911280	COUPLING	1	62330527
269	400486	NOZZLE HEAD	1	62330527
270	922027	THUMB SCREW	1	62330527
271	400557	ORIFICE - 1/4"	1	62330527
272	400556	ORIFICE - 3/8"	1	62330527
273	400552	ORIFICE - 1/2"	1	62330527
274	400520	NOZZLE CAP	1	62330527
<u>OPTIONAL PARTS USED WITH FINISHING NOZZLE</u>				
275	400553	ORIFICE - 9/16"	1	62330527
276	400554	ORIFICE - 5/8"	1	62330527
277	400555	ORIFICE - 3/4"	1	62330527
278	400487	24" NOZZLE EXTENSION ASSEMBLY	1	62330527
267	400523	EXTENSION TUBE	1	62330527
268	911280	COUPLING	1	62330527
259	400490	HOSE ASSEMBLY COMPLETE	1	62330527
260	947073	FEMALE SWIVEL INSERT - 1/4"	1	62330527
261	928043	CLAMP - 1/4"	2	62330527
262	947041	MALE BARBED INSERT - 1/4"	1	62330527

PAYMENT TERMS

Terms of payment for parts are net 10 days.

FREIGHT POLICY

All parts orders will be shipped collect or prepaid with the charges added to the invoice. All shipments are F.O.B. point of origin. Multiquip's responsibility ceases when a signed manifest has been obtained from the carrier, and any claim for shortage or damage must be settled between the consignee and the carrier.

MINIMUM ORDER

The minimum charge for orders from Multiquip is \$15.00 net. Customers will be asked for instructions regarding handling of orders not meeting this requirement.

RETURNED GOODS POLICY

Return shipments will be accepted and credit will be allowed, subject to the following provisions:

1. A Returned Material Authorization must be approved by Multiquip prior to shipment.
2. To obtain a Return Material Authorization, a list must be provided to Multiquip Parts Sales that defines item numbers, quantities, and descriptions of the items to be returned.
 - a. The parts numbers and descriptions must match the current parts price list.
 - b. The list must be typed or computer generated.
 - c. The list must state the reason(s) for the return.
 - d. The list must reference the sales order(s) or invoice(s) under which the items were originally purchased.
 - e. The list must include the name and phone number of the person requesting the RMA.
3. A copy of the Return Material Authorization must accompany the return shipment.

4. Freight is at the sender's expense. All parts must be returned freight prepaid to Multiquip's designated receiving point.
5. Parts must be in new and resalable condition, in the original Multiquip package (if any), and with Multiquip part numbers clearly marked.
6. The following items are not returnable:
 - a. Obsolete parts. (If an item is listed in the parts price book as being replaced by another item, it is obsolete.)
 - b. Any parts with a limited shelf life (such as gaskets, seals, "O" rings, and other rubber parts) that were purchased more than six months prior to the return date.
 - c. Any line item with an extended dealer net price of less than \$5.00.
 - d. Special order items.
 - e. Electrical components.
 - f. Paint, chemicals, and lubricants.
 - g. Decals and paper products.
 - h. Items purchased in kits.
7. The sender will be notified of any material received that is not acceptable.
8. Such material will be held for 5 working days from notification, pending instructions. If a reply is not received within 5 days, the material will be returned to the sender at his expense.
9. Credit on returned parts will be issued at dealer net price at time of the original purchase, less a 15% restocking charge.
10. In cases where an item is accepted for which the original purchase document can not be determined, the price will be based on the list price that was effective twelve months prior to the RMA date.
11. Credit issued will be applied to future purchases only.

PRICING AND REBATES

Prices are subject to change without prior notice. Price changes are effective on a specific date and all orders received on or after that date will be billed at the revised price. Rebates for price declines and added charges for price increases will not be made for stock on hand at the time of any price change.

Multiquip reserves the right to quote and sell direct to Government agencies, and to Original Equipment Manufacturer accounts who use our products as integral parts of their own products.

SPECIAL EXPEDITING SERVICE

A \$20.00 to \$50.00 surcharge will be added to the invoice for special handling including bus shipments, insured parcel post or in cases where Multiquip must personally deliver the parts to the carrier.

LIMITATIONS OF SELLER'S LIABILITY

Multiquip shall not be liable here under for damages in excess of the purchase price of the item with respect to which damages are claimed, and in no event shall Multiquip be liable for loss of profit or good will or for any other special, consequential or incidental damages.

LIMITATION OF WARRANTIES

No warranties, express or implied, are made in connection with the sale of parts or trade accessories nor as to any engine not manufactured by Multiquip. Such warranties made in connection with the sale of new, complete units are made exclusively by a statement of warranty packaged with such units, and Multiquip neither assumes nor authorizes any person to assume for it any other obligation or liability whatever in connection with the sale of its products. A part from such written statement of warranty, there are no warranties, express, implied or statutory, which extend beyond the description of the products on the face hereof.

PARTS AND OPERATION MANUAL

HERE'S HOW TO GET HELP

*PLEASE HAVE THE MODEL AND SERIAL NUMBER
ON-HAND WHEN CALLING*

PARTS DEPARTMENT

800-427-1244 or 310-537-3700

FAX: 800-672-7877 or 310-637-3284

SERVICE DEPARTMENT/TECHNICAL ASSISTANCE

800-478-1244 or 310-537-3700

FAX: 310- 537-4259

WARRANTY DEPARTMENT

888-661-4279, or 310-661-4279

FAX: 310- 537-1173

MAIN

800-421-1244 or 310-537-3700

FAX: 310-537-3927



MULTIQUIP INC.

POST OFFICE BOX 6254
CARSON, CA 90749
310-537-3700 • 800-421-1244
FAX: 310-537-3927
E-MAIL: mq@multiquip.com
WWW: multiquip.com

Atlanta • Boise • Dallas • Houston • Newark
Quebec, Canada • Manchester, UK • Rio De Janiero, BR • Guadalajara, MX

Free Manuals Download Website

<http://myh66.com>

<http://usermanuals.us>

<http://www.somanuals.com>

<http://www.4manuals.cc>

<http://www.manual-lib.com>

<http://www.404manual.com>

<http://www.luxmanual.com>

<http://aubethermostatmanual.com>

Golf course search by state

<http://golfingnear.com>

Email search by domain

<http://emailbydomain.com>

Auto manuals search

<http://auto.somanuals.com>

TV manuals search

<http://tv.somanuals.com>