

# OPERATION MANUAL



## **MODEL TP7X TILE SAW (ELECTRIC MOTOR)**

Revision #0 (03/04/11)

To find the latest revision of this  
publication, visit our website at:  
[www.multiquip.com](http://www.multiquip.com)



**THIS MANUAL MUST ACCOMPANY THE EQUIPMENT AT ALL TIMES.**



## **CALIFORNIA — Proposition 65 Warning**

Engine exhaust and some of its constituents, and some dust created by power sanding, sawing, grinding, drilling and other construction activities contains chemicals known to the State of California to cause cancer, birth defects and other reproductive harm.

Some examples of these chemicals are:

- Lead from lead-based paints.
- Crystalline silica from bricks.
- Cement and other masonry products.
- Arsenic and chromium from chemically treated lumber.

Your risk from these exposures varies, depending on how often you do this type of work. To reduce your exposure to these chemicals: **ALWAYS** work in a well ventilated area, and work with approved safety equipment, such as dust masks that are specially designed to filter out microscopic particles.

# SILICOSIS/RESPIRATORY WARNINGS

**⚠ WARNING**



**SILICOSIS WARNING**

Grinding/cutting/drilling of masonry, concrete, metal and other materials with silica in their composition may give off dust or mists containing crystalline silica. Silica is a basic component of sand, quartz, brick clay, granite and numerous other minerals and rocks. Repeated and/or substantial inhalation of airborne crystalline silica can cause serious or fatal respiratory diseases, including silicosis. In addition, California and some other authorities have listed respirable crystalline silica as a substance known to cause cancer. When cutting such materials, always follow the respiratory precautions mentioned above.

**⚠ WARNING**

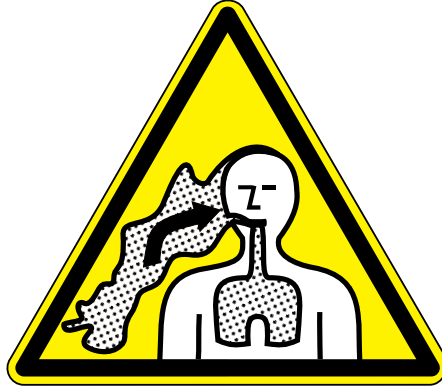

**RESPIRATORY HAZARDS**

Grinding/cutting/drilling of masonry, concrete, metal and other materials can generate dust, mists and fumes containing chemicals known to cause serious or fatal injury or illness, such as respiratory disease, cancer, birth defects or other reproductive harm. If you are unfamiliar with the risks associated with the particular process and/or material being cut or the composition of the tool being used, review the material safety data sheet and/or consult your employer, the material manufacturer/supplier, governmental agencies such as OSHA and NIOSH and other sources on hazardous materials. California and some other authorities, for instance, have published lists of substances known to cause cancer, reproductive toxicity, or other harmful effects.

Control dust, mist and fumes at the source where possible. In this regard use good work practices and follow the recommendations of the manufacturers or suppliers, OSHA/NIOSH, and occupational and trade associations. Water should be used for dust suppression when wet cutting is feasible. When the hazards from inhalation of dust, mists and fumes cannot be eliminated, the operator and any bystanders should always wear a respirator approved by NIOSH/MSHA for the materials being used.

# TABLE OF CONTENTS

---

## TP7X Tile Saw

Proposition 65 Warning .....	2
Silicosis/Respiratory Warnings .....	3
Table Of Contents .....	4
Safety Information .....	6-9
Specifications .....	10
Dimensions.....	11
General Information.....	12
Saw Components .....	14-15
Electric Motor Components/Set-Up.....	16
Set-Up .....	17-20
Sawing Guides .....	20-21
Operation.....	22-23
Maintenance.....	24-27
Wiring Diagram (Electric Motor) .....	28
Troubleshooting (Blade).....	30
Troubleshooting (Saw) .....	31

### NOTICE

Specifications are subject to change without notice.



# SAFETY INFORMATION

Do not operate or service the equipment before reading the entire manual. Safety precautions should be followed at all times when operating this equipment. Failure to read and understand the safety messages and operating instructions could result in injury to yourself and others.



## SAFETY MESSAGES

The four safety messages shown below will inform you about potential hazards that could injure you or others. The safety messages specifically address the level of exposure to the operator and are preceded by one of four words: **DANGER**, **WARNING**, **CAUTION** or **NOTICE**.

## SAFETY SYMBOLS

**!** **DANGER**

Indicates a hazardous situation which, if not avoided, **WILL** result in **DEATH** or **SERIOUS INJURY**.

**!** **WARNING**

Indicates a hazardous situation which, if not avoided, **COULD** result in **DEATH** or **SERIOUS INJURY**.



**!** **CAUTION**

Indicates a hazardous situation which, if not avoided, **COULD** result in **MINOR** or **MODERATE INJURY**.

**NOTICE**

Addresses practices not related to personal injury.

Potential hazards associated with the operation of this equipment will be referenced with hazard symbols which may appear throughout this manual in conjunction with safety messages.

Symbol	Safety Hazard
	Rotating parts hazards
	Cutting and crushing hazards
	Electric shock hazards

# SAFETY INFORMATION

## GENERAL SAFETY

### CAUTION

- **NEVER** operate this equipment without proper protective clothing, shatterproof glasses, respiratory protection, hearing protection, steel-toed boots and other protective devices required by the job or city and state regulations.



- Avoid wearing jewelry or loose fitting clothes that may snag on the controls or moving parts as this can cause serious injury.
- **NEVER** operate this equipment when not feeling well due to fatigue, illness or when under medication.
- **NEVER** operate this equipment under the influence of drugs or alcohol.



- **ALWAYS** clear the work area of any debris, tools, etc. that would constitute a hazard while the equipment is in operation.
- No one other than the operator is to be in the working area when the equipment is in operation.
- **ALWAYS** check the equipment for loosened threads or bolts before starting.
- **DO NOT** use the equipment for any purpose other than its intended purposes or applications.

## NOTICE

- This equipment should only be operated by trained and qualified personnel 18 years of age and older.
- Whenever necessary, replace nameplate, operation and safety decals when they become difficult read.
- Manufacturer does not assume responsibility for any accident due to equipment modifications. Unauthorized equipment modification will void all warranties.
- **NEVER** use accessories or attachments that are not recommended by Multiquip for this equipment. Damage to the equipment and/or injury to user may result.
- **ALWAYS** know the location of the nearest fire extinguisher.
- **ALWAYS** know the location of the nearest first aid kit.
- **ALWAYS** know the location of the nearest phone or **keep a phone on the job site**. Also, know the phone numbers of the nearest **ambulance, doctor and fire department**. This information will be invaluable in the case of an emergency.

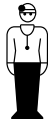



# SAFETY INFORMATION

## SAW SAFETY

### DANGER

- **NEVER** operate the equipment in an explosive atmosphere or near combustible materials. An explosion or fire could result causing severe **bodily harm or even death**.

### WARNING

- Accidental starting can cause severe injury or death. **ALWAYS** place the ON/OFF switch in the OFF position. 
- Keep hands away from moving parts at all times. 
- **NEVER** disconnect any **emergency or safety devices**. These devices are intended for operator safety. Disconnection of these devices can cause severe injury, bodily harm or even death. Disconnection of any of these devices will void all warranties.

### CAUTION

- **ALWAYS** ensure saw is **securely** placed on appropriate blocks or jackstands when maintenance requires elevation of the saw.
- If the machine malfunctions, stop the saw immediately and secure it. Fix the problem as soon as possible.

### NOTICE



- **ALWAYS** keep the machine in proper running condition.
- Fix damage to machine and replace any broken parts immediately.
- Make sure there is no buildup of grease, oil or debris on the machine.
- **ALWAYS** store equipment properly when it is not being used. Equipment should be stored in a clean, dry location out of the reach of children and unauthorized personnel.

## BLADE SAFETY

### WARNING

- Rotating blade can cut and crush. **ALWAYS** keep hands and feet clear while operating the saw. 

### CAUTION

- **NEVER** operate the saw without blade guards and covers in place. Exposure of the diamond blade must not exceed 180 degrees. 
- Verify the motor start switch is set to the OFF position before installing a blade.
- **ALWAYS** inspect blade before each use. The blade should exhibit no cracks, dings, or flaws in the steel centered core and/or rim. Center (arbor) hole must be undamaged and true. 

### NOTICE

- Use proper blades and follow blade manufacturer's recommendations. Match the blade RPM (blade shaft RPM) to the recommended blade surface feet per minute (SFPM).
- Ensure the blade-mounting bolt is tightened adequately
- **ALWAYS** examine blade flanges for damage and excessive wear.
- Ensure the blade is marked with an operating speed greater than the spindle speed of the saw.
- Only cut the material that is specified for the diamond blade. Read the specification of the diamond blade to ensure the proper tool has been matched to the material being cut.
- If wet cutting, ensure a **WET CUTTING** blade is being used and that the water supply system to the blade is properly functioning and being used.
- **DO NOT** drop the diamond blade on ground or surface.
- Ensure that the blade is mounted for proper operating direction.
- Adhere to the blade manufacturer's recommendations on handling, storage and safe usage of blades.



# SAFETY INFORMATION

## ELECTRIC MOTOR SAFETY

### NOTICE

- Operate electric motor only at the specified voltage indicated on the nameplate.
- **DO NOT** spray water onto electric motor.
- **ALWAYS** disconnect AC power plug from power source before moving saw, changing blade, or performing maintenance.
- **ALWAYS** make sure the ON/OFF switch on the electric motor is in the OFF position when not in use and before inserting the saw's power plug into an AC receptacle.



## Power Cord/Cable Safety

### DANGER

- **NEVER** let power cords or cables lay in water.
- **NEVER** use **damaged** or **worn** cables or cords when connecting equipment to generator. Inspect for cuts in the insulation.
- **NEVER** grab or touch a live power cord or cable with wet hands. The possibility exists of **electrical shock, electrocution or death.**
- Make sure power cables are securely connected. Incorrect connections may cause electrical shock and damage to the saw.

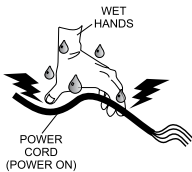

### CAUTION

- Ensure that cables and cords will not be tripped over or trapped underneath the saw.
- Never use the cable to pull out the plug from the power source.

### NOTICE

- **ALWAYS** make certain that proper power or extension cord has been selected for the job.
- Protect the cable from heat, oil, and sharp edges.

## LIFTING SAFETY

### CAUTION

- **NEVER** allow any person or animal to stand underneath the equipment while lifting.
- Some saws are very heavy and awkward to move around. Use proper heavy lifting procedures.
- **DO NOT** lift machine to unnecessary heights.
- **NEVER** lift the equipment while the motor is running.

## TRANSPORTING SAFETY

### NOTICE

- **ALWAYS** shutdown motor before transporting.
- **ALWAYS** tie down equipment during transport by securing the equipment with rope.
- Ensure that the diamond blade does not come into contact with the ground or surface during transportation.
- **NEVER** transport the saw to or from the job site with the blade mounted.

## ENVIRONMENTAL SAFETY

### NOTICE

- Dispose of hazardous waste properly. Examples of potentially hazardous waste are used motor oil, fuel and fuel filters.
- **DO NOT** use food or plastic containers to dispose of hazardous waste.
- **DO NOT** pour waste, oil or fuel directly onto the ground, down a drain or into any water source.



## SPECIFICATIONS

<b>Table 1. Saw Specifications</b>	
<b>Model</b>	TP7X
<b>Blade Capacity</b>	7 in. (178 mm)
<b>Blade RPM</b>	6000
<b>Arbor Size</b>	5/8 in. (15.875 mm)
<b>Blade Guard</b>	Cast Aluminum
<b>Blade Shaft Bearings</b>	Water-Cooled
<b>Cutting Head</b>	Cast Aluminum, Adjustable
<b>Conveyor Cart</b>	Aluminum with roller bearings, injected molded rubber pad, transportation lock
<b>Drive System</b>	T-belt
<b>Max. Depth of Cut</b>	1-3/4 in. (44.5 mm)
<b>Straight Cut</b>	20 in. (508 mm)
<b>Diagonal Cut</b>	14 in. (356 mm) x 14 in. (356 mm) Size Tile
<b>Water Tray</b>	ABS
<b>Water Pump</b>	115V, 60 Hz — 230 GPH
<b>Weight</b>	55 lbs. (25 kg)

<b>Table 2. Electric Motor Specifications</b>	
<b>Horsepower</b>	1
<b>Volts</b>	115
<b>Amps</b>	15
<b>Motor RPM</b>	21,500 RPM
<b>Cycle</b>	60
<b>Phase</b>	1
<b>Class</b>	E

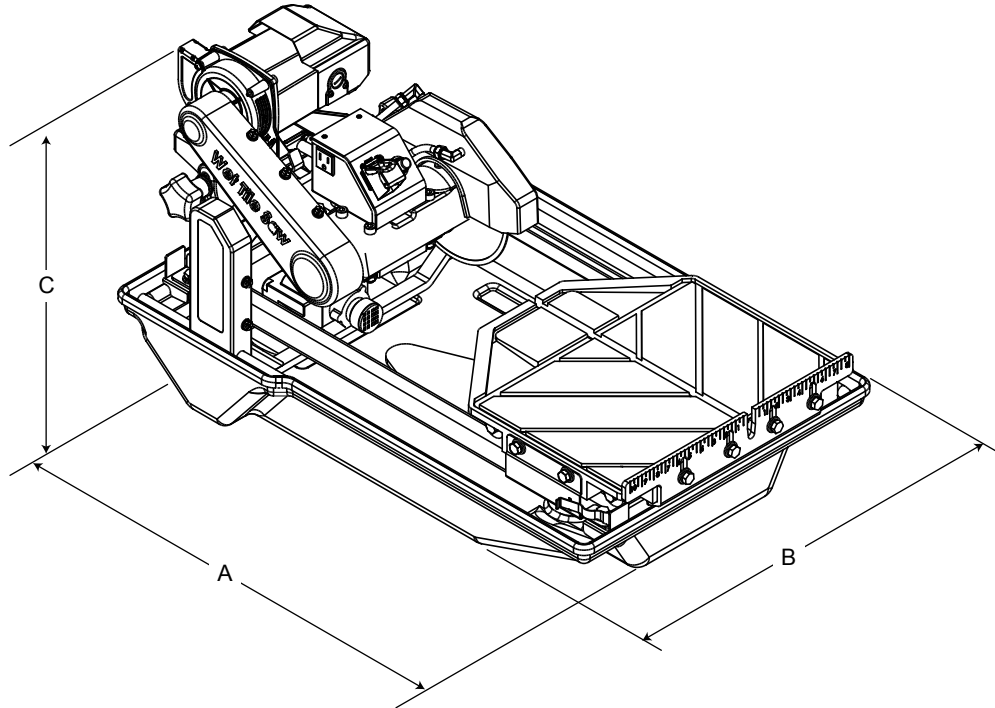

**Figure 1. Dimensions**

<b>Table 3. Dimension</b>	
<b>Reference Letter</b>	<b>Dimensions</b>
A	31.9 in. (811 mm)
B	19.6 in. (498 mm)
C	20.4 in. (518 mm)

# GENERAL INFORMATION

The TP7X is a powerful, robust saw designed to professionally handle large-sized cuts on ceramics, stone, and masonry materials. A sturdy steel precision frame and easily removable ABS water tray provides overall durability and longevity.

This saw is equipped with a trusted 1 HP electric motor that operates on standard 115 V power and is designed with thermal overload and fan air cover protection.

An innovative water-cooled bearing assembly works in conjunction with the water pump to keep key bearing components running cooler.

The TP7X saw comes complete with premium blade and high flow water pump.

## DRY CUTTING APPLICATIONS

The TP7X tile saw is shipped from the factory for wet-cutting saw applications, however it can be used for dry-cutting saw applications. The most important thing to remember is to disconnect the water pump. The water pump is cooled by the flow of water, and failure to disconnect the pump (when running dry) will cause pump failure.

### NOTICE

**NEVER** have the water pump engaged when dry cutting applications are involved.

## BLADE APPLICATIONS

This saw has been designed to incorporate the use of diamond blades as the cutting tool. The optimum performance of this saw is best evidenced by using 7-inch (178 mm) diamond blades that match the material being cut. Ask your dealer, or call Multiquip about your specific cutting application.

## ACCESSORIES/REPLACEMENT PARTS

If desired, the TP7X tile saw can be equipped with a support stand. This stand is ideal when the saw needs to be placed on a secure reliable platform.

## FEATURES

- **Rugged Portable Frame Assembly** — Sturdy steel frame design with handles for easy transport.
- **Electric Induction Motor** — UL/CSA approved 115 V 60 Hz, 1 HP electric motor with thermal overload and fan cover protection.
- **Water Tray** — Sturdy ABS water tray that is easily removable for cleaning.
- **Cutting Table** — Rugged cast aluminum table with heavy-duty injected molded rubber padding and extension table. Industrial ball bearing rollers ensure smooth, precise cart movement.
- **Water Pump** — Powerful submersible pump provides high volume water flow.
- **Water-Cooled Blade Shaft Bearing Assembly** — High flow water circulating system designed to keep crucial bearing components running cooler.
- **Blade Guard** — Hardy cast guard with blade brushes designed to evenly distribute water to the blade, and to easily position for blade changes.
- **Diamond Blade** — 7-inch (178 mm) premium tile blade included.



# SAW COMPONENTS

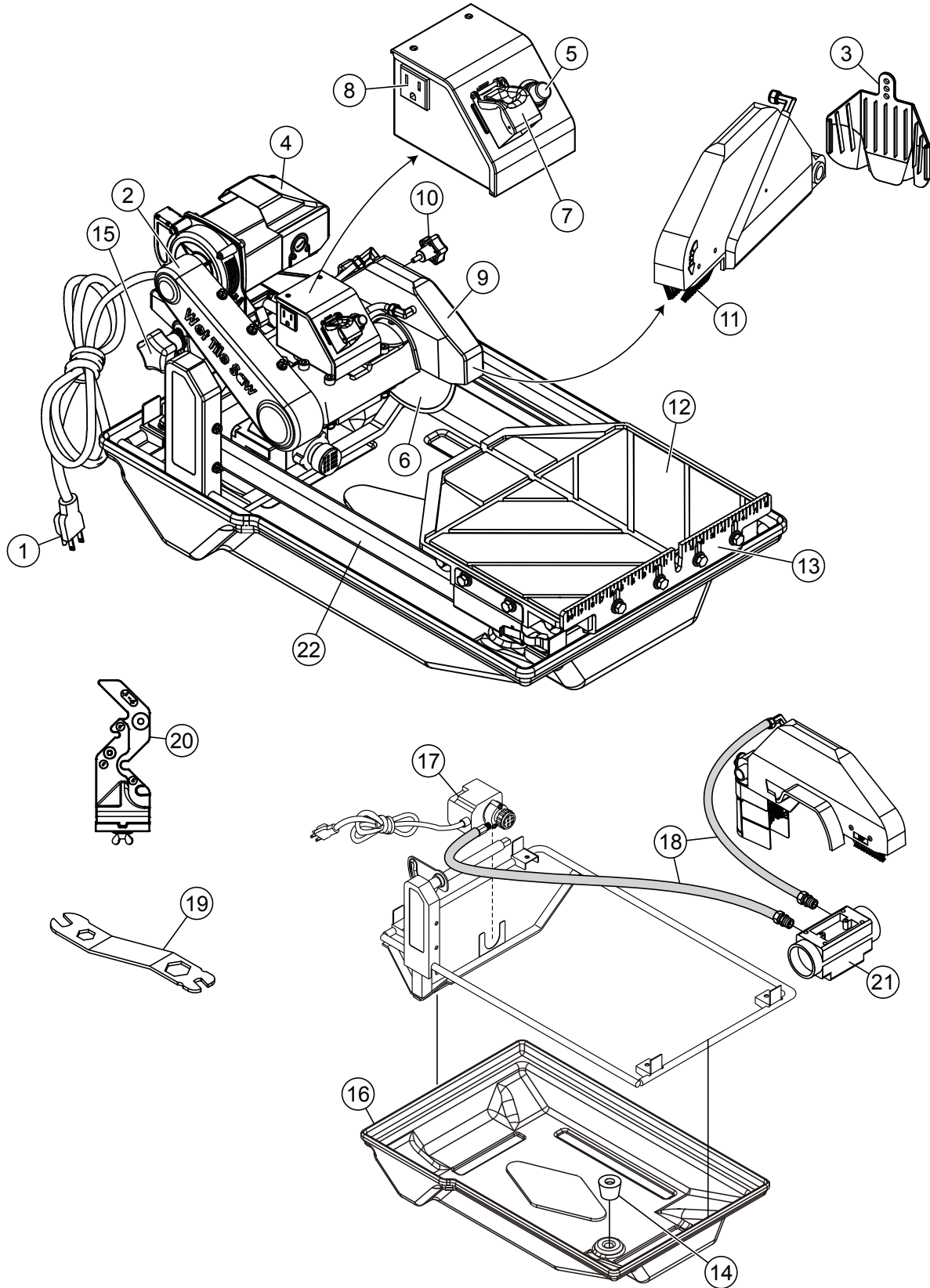

Figure 2. Saw Components

## SAW COMPONENTS

Figure 2 shows the location of the basic components of the TP7X saw. Listed below is a brief explanation of each component.

1. **AC Power Cord** — Plug this cord into a 125 VAC receptacle when starting of the electric motor is required.
2. **V-belt Cover** — Remove this cover to access the drive V-belt. **NEVER** operate the saw with the V-belt cover removed
3. **Rubber Splash Guard** — Keeps water from splashing from the blade.
4. **Electric Motor** — This unit uses a 115V, 60 Hz, 1 HP electric motor.
5. **Overcurrent Breaker Button** — When a thermal overload condition exists, press this button to reset the breaker. Allow time for the electric motor to cool down before resetting the breaker.
6. **Cutting Blade** — This unit uses a 7-inch (178 mm) premium diamond blade. Always use recommended Multiquip cutting blades. When mounting of the cutting blade is required, remove the spindle bolt and outside blade flange. Align cutting blade with inside flange arbor and reassemble spindle and outside blade flange.
7. **Power ON/OFF Switch** — To turn on the saw place in the ON position. Place in the OFF position to shut down the saw.
8. **Water Pump Power Receptacle** — Plug the water pump power cord into this AC receptacle.
9. **Blade Guard** — Protects the user from the cutting blade. **NEVER** operate the saw with the blade guard removed.
10. **Blade Guard Adjustment Knob** — Turn knob clockwise to loosen and remove blade guard. Turn counterclockwise to tighten.
11. **Blade Guard Brushes** — Prevents foreign matter and debris from accumulating on the saw blade. Replace brushes immediately when they become worn or damaged.
12. **Cutting Table** — Place material to be cut on this rubber padded table. For ease of cutting, this table has been placed on rails so that it can easily slide back and forth.
13. **Ruler Backstop** — When cutting, place material against backstop. Use measurement rail (ruler) to determine where material is to be cut.
14. **Stopper** — Place stopper in water tray when filling with water.
15. **Cutting Head Adjustment Knob** — Turn knob clockwise to loosen and position cutting head to desired height. Turn counterclockwise to tighten.
16. **Water Tray** — When wet cutting is required, fill with clean fresh water. Make sure submersible pump is totally immersed in water.
17. **Electric Water Pump** — The electric water pump for this saw requires 115 VAC. Plug power cord of electric water pump into AC receptacle located on conduit box. **NEVER** run pump dry. Pump must be immersed in water.
18. **Water Lines** — Replace the clear vinyl tubing water lines when they become brittle, worn or clogged. Water kits are available through your Multiquip dealer.
19. **Maintenance Wrench** — Use this multi-purpose wrench when performing maintenance or repairs on the saw.
20. **MasterGuide Template Base** — Mounts to ruler backstop to ensures precision while making cuts.
21. **Bearing Housing** — Houses permanently lubricated ball bearings to allow motor shaft to rotate smoothly.
22. **Metal Frame Handles** — There are two carrying handles on each side of the saw. Grip these handles when transporting of the the saw is required.

# ELECTRIC MOTOR COMPONENTS/SET-UP

## ELECTRIC MOTOR COMPONENTS

Figure 3 shows the location of the components of the electric motor.

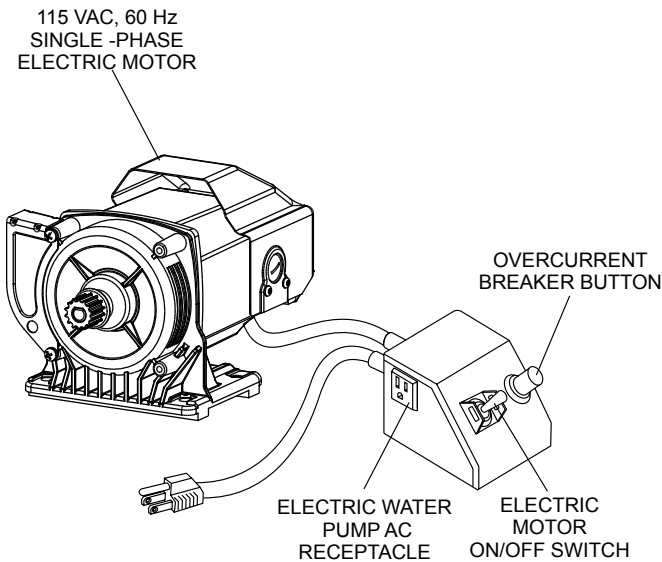

Figure 3. Electric Motor Components

## SAW SET-UP

### **WARNING**

Whenever cleaning, adjusting or lubricating any part of the saw, make certain to place the power ON/OFF switch in the **OFF** position and disconnect the plug from the power source.

1. Open the shipping container carefully, lift the saw by its carrying handles and place it on a suitable table or platform. Make sure the table or platform can support the weight of the saw.
2. Make sure that the following items are found in the container:
  - Saw
  - Water Tray
  - Drain Plug
  - Universal Wrench
  - Saw Blade
  - Water Pump
  - Owner's Manual
  - MasterGuide Template Base

3. Slide water pump onto U-shaped bracket located at the bottom of the frame. See Figure 6.
4. Slide cutting head onto the post. Secure cutting head to the shaft using provided flat washer, lock washer and nut. Attach cutting depth control knob and washers to the cutting head through the slot located underneath the belt guard. See Figure 4.
5. Mount blade guard onto shaft protruding from the side of the cutting head. Secure the blade guard in place using the provided serrated washer and blade guard knob.

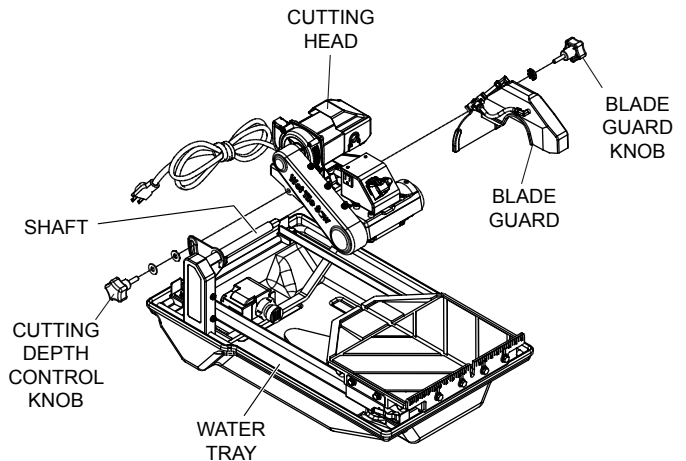

Figure 4. Saw Assembly

6. If using the optional support stand, assemble as described in the Support Stand Assembly section. Make sure that the saw is secured on the support stand as instructed.

## SUPPORT STAND ASSEMBLY (OPTIONAL)

Refer to Figure 5 for location of components.

1. Remove the folding stand from its box.
2. Swing the working bench upright. Open the two legs and place the work bench on top of the folding stand.
3. After the saw stand is assembled, seat the saw securely on top of the stand.



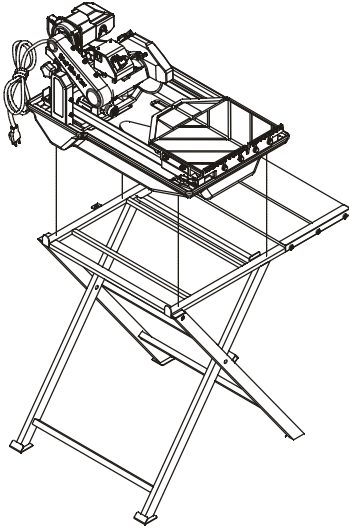
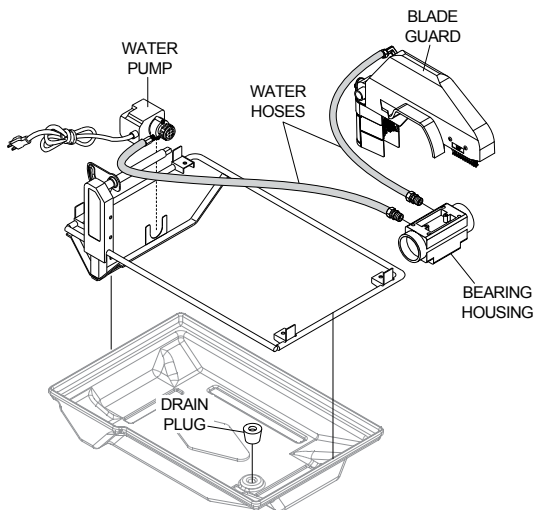

**Figure 5. Support Stand Assembly**

## CONNECTING THE WATER PUMP

Refer to Figure 6.

1. Place the pump into the middle of the water tray along its side so that the water outlet is positioned horizontally.
2. Attach the water hose coming from the blade guard and bearing housing to the water pump.
3. Install drain plug in water tray.
4. Fill the water tray with clean fresh water. The water pump intake must always be fully covered by water. Also, keep the pump intake free of sludge, debris and other materials that may accumulate in the tray.
5. Make certain that the water hose will not come in contact with the blade or interfere with any moving parts.



**Figure 6. Connecting the Water Pump**

6. Insert the water pump power plug into the outlet receptacle on the electric motor conduit box as shown in Figure 7.

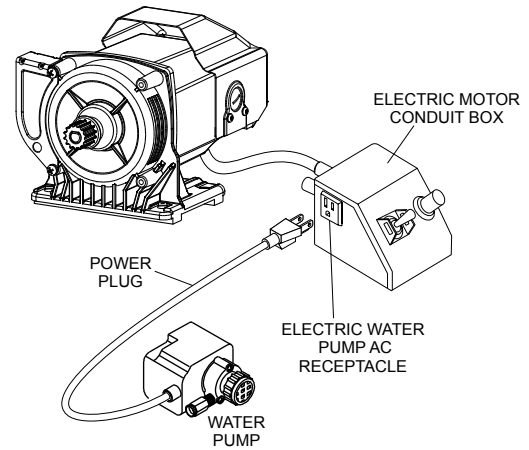

**Figure 7. Water Pump Power Connection**

### **WARNING**

Disconnect the pump before attempting to handle the pump. **NEVER** operate pump without water in the tray.

### **NOTICE**

The above procedure is for wet cutting applications only. **NEVER** dry cut with the pump connected to an AC power source. Running the pump dry will damage the pump. **ALWAYS** disconnect the pump's power cord when dry cutting.

## BLADES

**WARNING**



Failure to thoroughly inspect the blade for operational safety could result in damage to the blades or the saw and may cause serious injury to the user or others in the operating area. Inspect the blade flanges and shaft for damage before installing the blade.

### Blade Components

Diamond blades are recommended for your saw. Ask your Multiquip dealer about your specific cutting application. Figure 8 highlights the components of a diamond blade.

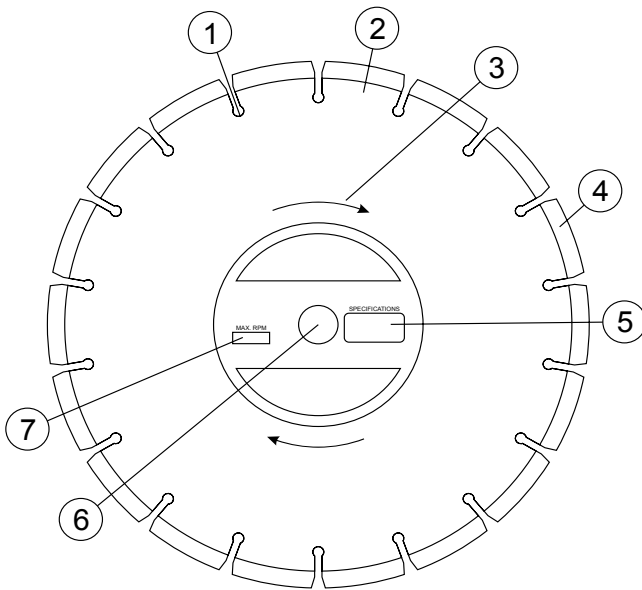

**Figure 8. Diamond Blade**

1. **Stress Relief Holes (Gullets)** — Check the steel core for cracks that may have propagated from the slots and/or gullets. Cracks indicate extreme fatigue failure and if sawing continues, catastrophic failure will occur.
2. **Edge of the Steel Core** — Check the diameter edge for discoloration (blue oxidation) indicating an overheating condition caused by insufficient cooling water/air. Overheating of blades may lead to loss of core tension and/or increase the possibility for blade failure. Check to make sure the steel core's width is uniform about the rim of the blade, and not succumbing to an "under cutting" condition brought about by highly abrasive material or improper under cutting core protection.

3. **Directional Arrow** — Check to ensure that the blade is oriented properly on the spindle for sawing. Reference the directional arrow on the blade and place it so the direction of rotation "downcuts" with the turn of the shaft.
4. **Diamond Segment or Rim** — Ensure that there are no cracks, dings, or missing portions of the diamond segment/rim. **DO NOT use a blade that is missing a segment or a portion of the rim.** Damaged and/or missing segments/rims may cause damage to your saw and injury to the user or others in the operating area.
5. **Specifications** — Ensure that the blade specifications, size, and diameter properly match up to the sawing operation. Wet blades must have water to act as a coolant. Utilizing a diamond blade not matched properly to the task may result in poor performance and/or blade damage.
6. **Arbor Hole** — It is essential that the arbor hole diameter properly matches the shaft arbor, and that it is free from distortions. Correct blade flanges (collars) must be used. The inside face of the flanges must be clean and free of debris. An out of round arbor condition will cause damage to the blade and the saw.
7. **MAX RPM** — This RPM reference is the maximum safe operating speed for the blade selected. **NEVER** exceed the max RPM on the diamond blade. Exceeding the MAX RPM is dangerous, and may cause poor performance and may damage the blade. All blades used must be designed for the maximum spindle RPM.

### Cutting Depth

The recommended cutting depth is 1/4" (6 mm) below the cutting table surface. To adjust the cutting depth, loosen the cutting head adjustment knob so that the blade is 1/4" below the top of the cutting table's surface. See Table 4 to determine cutting depth by blade diameter.

**WARNING**

Setting the blade too low may damage the cutting table and if set too high, the blade may grab the material being cut, causing damage and possibly injury.

Table 4. Blade Diameter vs. Cutting Depth	
Blade Diameter	Cutting Depth
7 in. (178 mm)	1-3/4 in. (44.5 mm)

## Blade Installation

Refer to Figure 9 and the following instructions for installing the blade.

1. Loosen blade guard adjustment knob located at the rear of the blade guard. Carefully raise the cutting head to its highest position and secure it into place by tightening the blade guard adjustment knob.
2. Remove the blade shaft nut and outer flange. If a blade has been mounted, hold the blade with one hand and use the other hand to loosen the nut with the universal wrench. Remove existing blade.
3. Mount new blade, but make certain the arrow on the blade coincides with the rotation direction of the shaft. Ensure the capacity of the blade guard matches the diameter of your cutting blade.
4. Attach outer flange and blade shaft nut. Hold the blade with one hand and use the other hand to tighten the nut with the universal wrench. Make certain the flanges are pressed flush against the blade and that the nut is firmly tightened, but **DO NOT** over tighten.
5. Loosen blade guard adjustment knob, lower the blade guard, and retighten the knob.
6. Slightly loosen the cutting head adjustment knob, lower the cutting head so that the blade is 1/4" (6 mm) below the surface of the cutting table. Tighten the adjustment knob firmly to hold the cutting head in place.

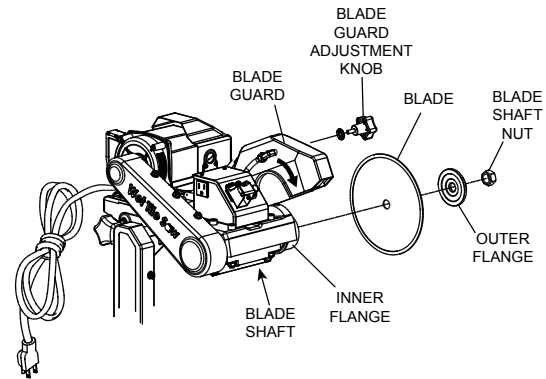

**Figure 9. Blade Installation**

See Table 5 for proper blade use guidelines.

Table 5. Proper Blade Use	
Dos	Don'ts
Inspect blades daily for cracks or uneven wear.	Do not operate the saw without safety guards in place.
Always use appropriate blades for material being cut.	Do not operate the saw with blades larger than 7 in. (178 mm)
Inspect arbor shaft for uneven wear before mounting blade.	Do not cut dry with blades marked "Use Wet".
Always use blades with the correct arbor shaft size.	Do not exceed manufacturer's recommended maximum RPM.
Ensure that blade is mounted in the correct direction.	Do not force blade into material. Let blade cut at its own speed.
Use proper safety equipment when operating the saw.	Do not make long cuts with dry blades. Allow them to air cool.
Always have a continuous flow of water on both sides of blade.	Do not use the edge or side of blade to cut or grind.
Secure the blade to the arbor with a wrench.	Do not attempt to cut a radius or curve.
Inspect segment blades for segment cracking or loss.	Do not cut too deep or too fast into the material.
Do not use damaged blades.	Do not cut any material not recommended by blade manufacturer.

# SET-UP/SAWING GUIDES

## CONNECTING THE POWER

1. Place the power ON/OFF switch (Figure 10) in the OFF position (down).
2. Connect an extension cord of adequate current carrying capacity to the power plug on the electric motor.
3. **MAKE CERTAIN** that the correct size extension cord is used. Undersized wires will burn out motors. Use Table 6 to determine the correct extension cord size.

Table 6. Extension Cord Sizes				
Motor	Voltage VAC	25 ft (7.6 m) Long	50 ft (15.2 m) Long	75 ft (22.9 m) Long
1 HP	115	No. 12	No. 10	No. 8

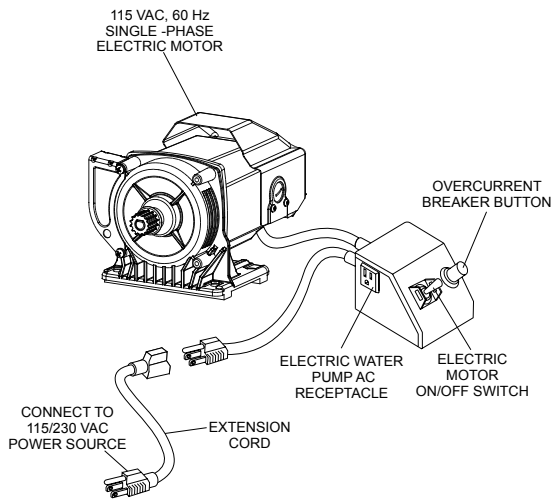

Figure 10. Extension Cord Connection

4. Plug the free end of the extension cord into an AC power receptacle. Whenever possible use a GFCI receptacle (Figure 11) to reduce the risk of electrical shock.

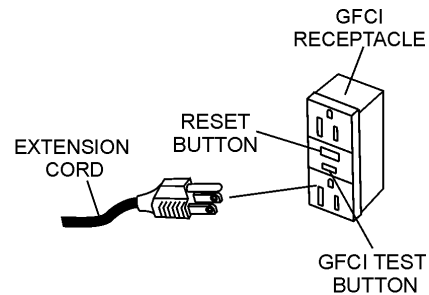

Figure 11. GFCI Receptacle

## SAWING GUIDES

### Using the Cutting Table

- The ruler guide has inches and centimeters marked along the top to allow convenient measurements and to promote precision cuts. See Figure 12.
- A rip guide should be used with the cutting table to ensure precision while making cuts.

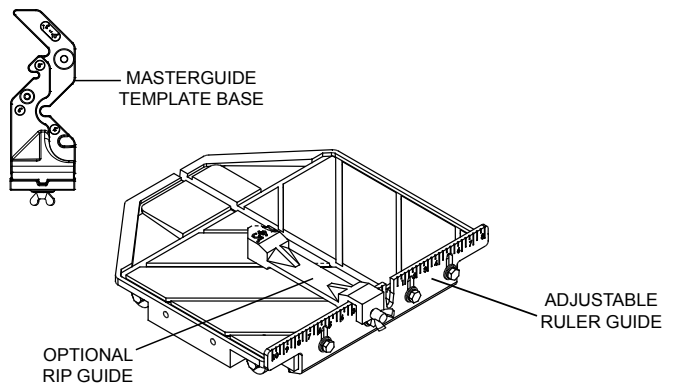

Figure 12. Cutting Table

### Using the MasterGuide Template Base

1. Set the template base (Figure 12) by positioning it on the desired dimension on the cutting table and tightening the universal clamp to the table. Make sure that the template base is firmly tightened. The template base can be used for 90° rip cuts from both the left and right side. The 45° diagonal cuts are quickly achieved with the specially designed fitted notches on the template base of 4", 6", 8" and 10"~14" tiles (Note the specifically shown dimensions on each notch).

**DANGER**

WET HANDS

POWER CORD (POWER ON)

**NEVER** grab or touch a live power cord with wet hands, the possibility exists of electrical shock, electrocution, and even death!

**NEVER** use a damaged or worn extension cable when connecting to a power source. Defective cables may cause damage to the saw's electric motor or electrical shock.

**ALWAYS** use a grounded (3-wire) extension cord and **MAKE CERTAIN** that the motor is connected to a properly grounded electric circuit. If possible use a ground fault circuit interrupter to protect the operator from possible electric shock.

2. After the template base is positioned for the desired rip cut, place material flat against either side of the template base at the desired measurement.

## Using the Rip Guide

1. Set the rip guide (Figure 12) at the desired location on the ruler guide and tighten the threaded knob. Make sure that the rip guide is firmly tightened to avoid slippage. The rip guide can be used for 45° and 90° cuts.
2. After the rip guide is positioned, for the desired cut, place material flat against the rip guide and ruler guide.
3. Now you are ready to make your cut.

## Performing Diagonal Cuts

1. Place the corner of the material in the open slot of the measurement rail and adjust the template base to fit the correct tile size.
2. Line up the material being cut with the appropriate pre-marked lines on the cutting table.
3. Now you are ready to make your cut.

## Performing Miter Cuts

Use the miter block to make miter cuts. See Figure 13.

1. Place the lip of the miter block on the ruler guide with the threaded knob facing you.
2. Position the miter block such that a tile laying flat against the block may rest its left-most edge within the vertical channel of the cutting table. Tighten the threaded knob to secure the miter block in place.
3. Place material onto miter block and you are ready to cut.

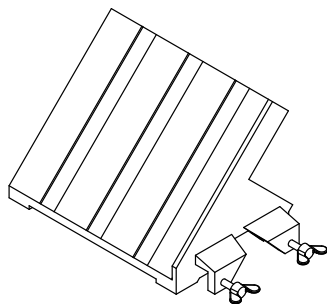

**Figure 13. Miter Block**

## START-UP PROCEDURE

### NOTICE



Read and fully understand this manual before starting or attempting to operate the saw.

Before starting the saw's electric motor make sure that the Safety, General Information, and Set-Up sections have been completed and understood. **DO NOT** proceed until the above mentioned sections have been completed.

### NOTICE

**ALWAYS** use the water feed system unless special dry cut blades are being used. If dry cutting is required, disconnect water pump.

### WARNING



**ALWAYS** wear approved eye and hearing protection before operating the saw.

### WARNING



**NEVER** place hands or feet inside the belt guard or blade guard while the motor is running. **ALWAYS** shut the motor down before performing any kind of maintenance

### WARNING



**NEVER** place hands and fingers near the cutting blade. The possibility exists of severe bodily harm if hands and fingers come in contact with rotating saw blade.

### WARNING



**ALWAYS** ensure that the cutting blade has been mounted correctly.

### DANGER

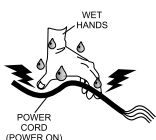

**NEVER** touch a live power cord with wet hands. The possibility exists of electrical shock, electrocution which could cause severe bodily harm, even death.

### WARNING



**NEVER** lift the blade guard while the blade is rotating. The possibility exists of severe bodily harm if fingers or hands come in contact with the rotating saw blade. Wait for the blade to stop rotating before lifting the blade guard.

1. Place the material to be cut (Figure 14) on the cutting table against the backstop.

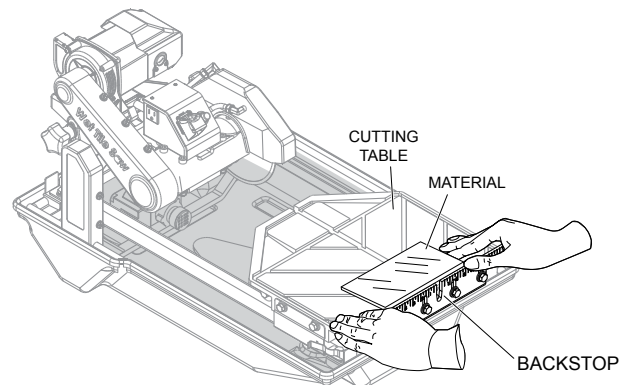

Figure 14. Material Placement

### DANGER

**ALWAYS** be alert to the fact that there is a rotating blade on the saw and be extremely aware of your body position — especially your hands in relationship to the rotating blade. The possibility exists of severe bodily harm or even death if your body comes in contact with the rotating saw blade.

2. Turn the power ON/OFF switch (Figure 15) to the ON position with the blade away from the material to be cut, the cutting blade should begin to rotate. Before cutting remember to follow all safety rules referenced in this manual.

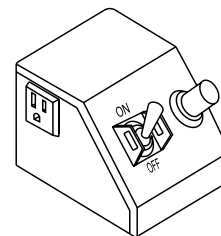
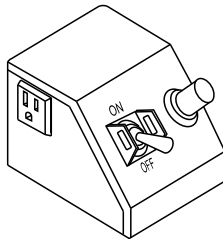

Figure 15. Power ON/OFF Switch (ON)

3. Push the cutting table with the material, slowly and evenly until the cut is complete. Move the cutting table back and remove the cut pieces.
4. Avoid overloading the motor when cutting. However, the electric motor is protected with a manual-reset thermal overload switch that will turn the saw off if the motor is overheated. In the event that the switch is tripped, turn the "ON/OFF" switch to the "OFF" position and allow the motor to cool before attempting to restart.

## SHUT DOWN PROCEDURE

1. Place the power ON/OFF switch (Figure 16) in the OFF position (down).



**Figure 16. Power ON/OFF Switch (OFF)**

2. Wait for the cutting blade to stop rotating.
3. Disconnect the saw's AC power cord from the power source. **NEVER** leave the saw connected to a power source when unattended. This will prevent accidental starting.
4. Using a soft cloth, clean any excess debris or residue that may have accumulated on the saw.
5. Store saw in a clean dry location where it will be out of the reach of children.

A good preventive maintenance program of regular inspection and care will increase life and improve the performance of the saw and cutting blades.

## WARNING

Whenever cleaning, adjusting, or lubricating any part of the saw, **MAKE CERTAIN** to do the following:

- Place power ON/OFF switch to the **OFF** position.
- Disconnect power cord from AC source.
- **NEVER** attempt to check the V-belt with the engine running. Severe bodily injury can occur.

## BASIC MAINTENANCE

1. Tighten loose nuts or screws and replace any cracked or broken parts.
2. Clean the machine frequently. **DO NOT** use aggressive cleaners (i.e. containing solvents). **DO NOT** use high high-pressure water jets, aggressive detergents or solutions and liquids with a temperature exceeding 86°. Use a fluff-free cloth only. Use a cloth which may be lightly moistened only for removing dust and dirt. Hard packed dirt can be removed with a soft brush.  
**DO NOT** let any water/cleaning liquid/vapor penetrate into the electric motor, connectors/plugs, switches, etc. Cover all apertures, holes in the housing, connectors or plugs, etc, or seal them with adhesive tape.  
Use a soft, low-pressure water jet and a brush to rinse dirt and incrustations away. Be particularly careful when near hazardous parts of the machine (e.g. switch, motor). Clean the motor and switches only by wiping with a moist cloth.
3. Remove the belt guard and clean the pulleys. The belts and pulleys will wear rapidly if excessive dust builds up.
4. Clean the sludge that accumulates on the bottom of the water tray at least once a day and refill with clean water. It may be necessary to clean the tray out twice a day in heavy cutting. The sludge is abrasive and will shorten the life of the water pump and blades.
5. After each day's use, run clean water through the water pump and water hoses. This extends pump and blade life.
6. After cleaning, remove all covers and adhesive tape. All screws or nuts which may have been loosened must be retightened.
7. Check the spindle bolt for tightness periodically.
8. Keep the drive belt tight. It is very important to replace worn belts as soon as possible. To adjust belt tension, loosen the four (4) motor mounting bolts and remove the belt guard. Tighten the adjusting nut on the back of the motor plate to increase the tension. Proper belt tension is 4-5 lbs. of force with approximately 3/16" of belt deflection measured at a point midway between the pulleys. Tighten the motor mounting bolts and reattach the belt guard.
9. **MAKE CERTAIN** that the cutting head is aligned properly. Misalignment can adversely affect blade life.
10. The blade flanges must have a diameter of 4". Undersized flanges will reduce blade life and cause breakage. Therefore, they should be replaced at once.
11. Cutting blades must fit the arbor snugly. This is very important with diamond blades as pounding will occur and serious blade damage can result. If the arbor shoulder of the inner blade flange is grooved from blade slippage, the flange must be replaced.
12. Inspect the cutting table periodically. Replace worn parts.
13. **DO NOT** "rinse" the bearings of the drive elements to prevent them from running dry. The ball bearings of the machine are permanently lubricated.
14. Replace the spindle bearings as soon as they begin to make any strange noises. Worn bearings can destroy blades very quickly.
15. Grease pivot bearings periodically.



## MAINTENANCE INTERVALS

Use the following guidelines to perform maintenance on your saw.

### After every use of the machine

- Remove dirty water from container.
- Remove dirt and mud from the bottom of the container.
- Rinse the immersion pump with fresh water to prevent water pump clogging from residual dirt.

### After wet cleaning and before using the machine again

- Connect the machine to an electric power outlet equipped with a “GFCI” safety power breaker. If the safety power breaker cuts off the electrical power supply, do not try to operate the machine but have it checked by an authorized dealer first.

### Before not using the machine for a prolonged period of time

- Clean and lubricate all movable parts. **DO NOT** grease guide rails.

### After not using the machine for a prolonged period of time

- Check that the stand is safely fixed.
- Check that all screw joints and nuts are fixed.
- Check that the cutting table is seated properly on the guide rails and that it easily moves along the entire length of the rails.
- With the saw blade removed, switch on the motor for an instant and switch it off again. If the motor does not run, have the machine inspected by a qualified electrician.

- Check that the immersion pump works properly. Turn on the cooling water tap and switch the machine on. If the pump does not give any water or only a little, switch the machine off at once. Clean the pump, or replace if necessary.

### Ambient temperature below 32°F / 0°C (operation in winter)

- To prevent the water in the pump and cooling system from freezing, remove the water after using the machine or when there will be a long break. Make sure that the cooling system is entirely drained so that there is no water left inside the pump and water hose.

## CLEANING THE WATER TRAY

Refer to Figure 17.

Lift the saw up from inside the water tray.

1. Remove the drain plug and drain any water left inside the water tray.
2. Flush water into tray while holding it upright to remove any sludge buildup.
3. Replace the saw back into the water tray.

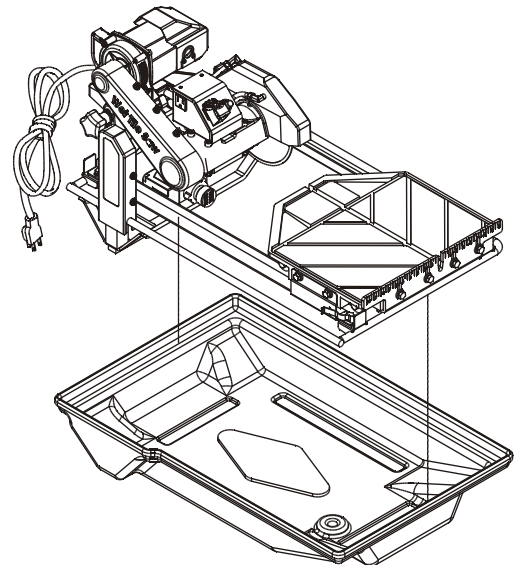

Figure 17. Water Tray Removal

## WATER PUMP MAINTENANCE

When the machine has not been used for a long period of time, hard packed dirt may build up inside the pump and block the pump wheel.

### NOTICE

If the machine is activated with the immersion pump blocked, the electric motor will be damaged within a few minutes!

Please follow the steps below to clean the pump before operating the saw.

1. Remove the immersion pump from the water container.
2. Clean the immersion pump.
3. Loosen the fixing screws of the pump lid.
4. Take the lid off the pump (be careful not to damage or lose the gasket underneath)
5. Clean the pump lid.
6. Remove all dirt and incrustations from the pump wheel.
7. Check whether the pump wheel can be easily turned.
8. Reassemble the immersion pump and check that it works properly.

## BELT REPLACEMENT

To replace the belt (Figure 18) perform the following.

1. Turn off and unplug the saw.
2. Loosen and remove the belt guard screws and take off the belt guard.
3. Loosen the 6 nuts on the cutting head's supporting arm.
4. Leave the blade in position, and use your hand to hold the blade shaft tightly. Now loosen the pulley lock screw on the rear of the motor pulley shaft.
5. Carefully loosen the pulley and belt outward slightly, so there is a little slack in the belt.
6. Take off the old belt and replace with a new one.

7. To reassemble, follow steps in reverse order.

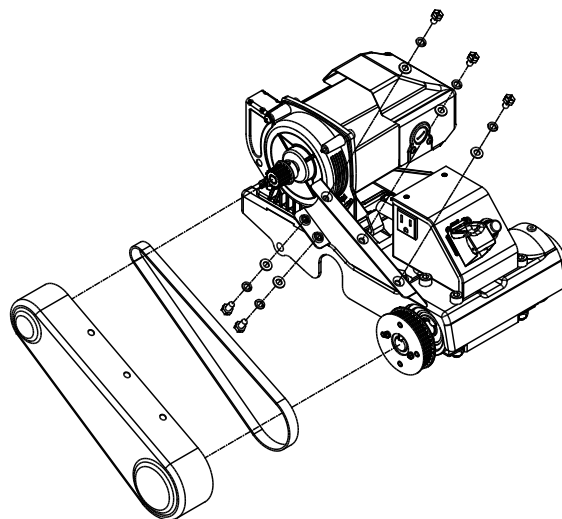

Figure 18. Belt Replacement

## CUTTING HEAD REMOVAL

To remove the cutting head, see Saw Set-Up and Figure 4 and perform the steps in reverse.

## BEARING HOUSING REMOVAL

To remove the bearing housing (Figure 19), perform the following:

1. Follow steps 1-6 of the Belt Replacement Section.
2. Remove the blade lock nut and remove the blade (if there is one present.)
3. Remove the precaution label and loosen the 4 screws at the front of the cutting head. Remove the bearing housing and inner flange.

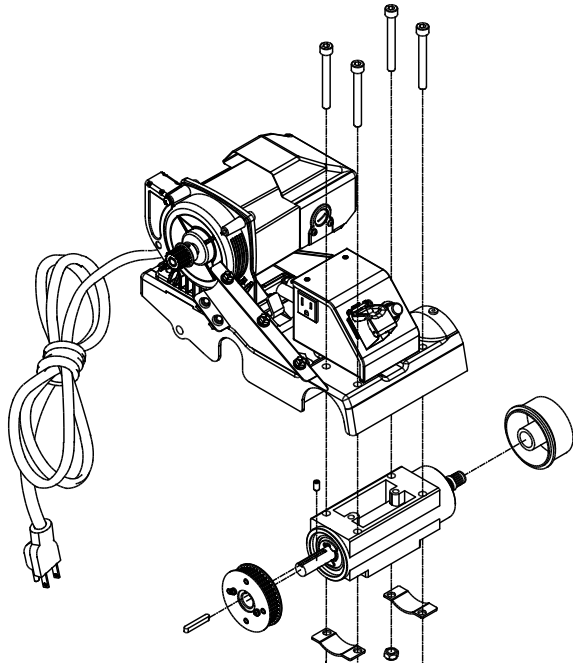

**Figure 19. Bearing Housing Removal**

## BEARING HOUSING INSTALLATION

To install a new bearing housing, perform the following:

1. Make sure that the old housing has been properly removed.
2. Unpack the new bearing housing and place the flat portion face-down on a towel situated on a flat surface.
3. Secure the cutting head in a in a completely horizontal position.
4. Slide the new bearing housing with the flat portion facing upwards onto the 4 screws located below the mounting plate. Take care not to damage the inner flange. Lock the bearing housing into place by using the brackets and nuts.
5. Pull the motor towards you, place the belt on the pulleys, and tighten the motor position adjustment screw. Be sure to leave some slack on the belt.
6. Align the belt by adjusting the motor pulley after loosening the hex screw.

### **⚠ WARNING**

Do not adjust the bearing housing pulley.

7. After aligning the belt, tighten the hex screw.
8. Replace the belt guard and lock into place using 4 screws.

# WIRING DIAGRAM (ELECTRIC MOTOR)

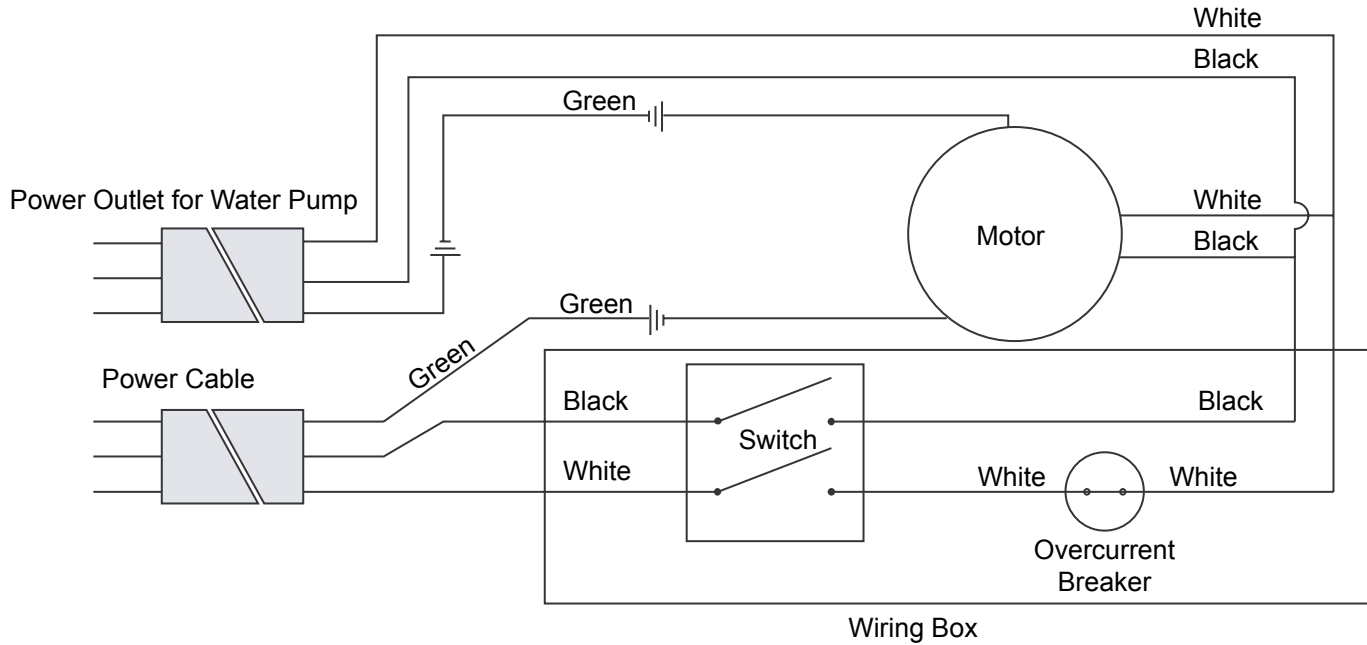

Figure 20. Electric Motor Wiring Diagram



# TROUBLESHOOTING (BLADE)

**Table 7. Blade Troubleshooting**

Symptom	Possible Problem	Solution
Irregular run of the saw blade	Poor tension in the blade material	Return saw blade to manufacturer
Saw blade wobbles when running	Saw blade is damaged or bent	Have the saw blade aligned/flattened
		Clean the receiving flange
		Replace saw blade.
	Flange of the saw blade is damaged	Replace the saw blade flange
	Shaft of the motor is bent	Replace the electric motor
Diamond segment becomes loose	Overheating of the saw blade; cooling water not sufficient	Replace saw blade.
Excessive wear	Wrong type of saw blade	Use harder saw blade
	Shaft of motor causes wobbling	Have motor or bearings of motor replaced
	Overheating	Ensure optimum flow of cooling water
Cracks in or near diamond segment	Saw blade too hard	Use softer blade
	Fixed flange is worn out	Have fixed flange replaced
	Motor shaft bearing	Replace the bearing of the motor shaft
Saw blade is blunt	Saw blade type is unsuitable for the material being cut	Use appropriate type of saw blade
	Saw blade type is unsuitable for the machine performance	
	Saw blade too hard	
	Diamond segments are blunt	Replace saw blade.
Appearance of cut is not optimal	Poor tension in the blade material	Return saw blade to manufacturer
	Too much load placed on saw blade	Use a suitable saw blade
	Diamond segments are blunt	Replace saw blade.
Center hole in saw blade has become wider due to wear	Saw blade has slipped on the motor shaft when running	Arbor of the saw blade must be fitted with an appropriate adapter ring
		Check the receiving flange and have it replaced if necessary
Saw blade shows blooming colors	Saw blade overheating due to lack of cooling water	Ensure optimum flow of cooling water
	Lateral friction when cutting	The material feed is too high; proceed more slowly
Grinding marks on the saw blade	Material is not being fed parallel to saw blade	Ensure that the direction of the feed is absolutely parallel to the saw blade
		Adjust roller table
	Poor tension in blade material	Have the saw blade tensioned
	Too much load on the saw blade	The material feed is too high; proceed more slowly

# TROUBLESHOOTING (SAW)

**Table 8. Saw Troubleshooting**

Symptom	Possible Problem	Solution
Machine does not run when switched on	Power cord not properly fixed/plugged in	Check that the machine is properly connected to the power supply
	Power cord defective	Have the power cord checked, replace if necessary
	Main power switch defective	Have the main power switch checked and replaced if necessary by a qualified electrician
	Loose electrical connection inside the electric system	Have the whole electric system of the machine checked by a qualified electrician
	Motor defective	Have the motor checked and replaced if necessary by a qualified technician
Motor stops (power cuts out)	Too much pressure exerted while cutting	Exert less pressure when cutting
	Incorrect specification for saw blade	Use a saw blade which corresponds to the material being cut
	Saw has a defective electric system	Have the electric system of the saw checked by a qualified technician
Poor machine performance, little power	Power cord/extension cable too long or cable still wound up inside cable drum	Use a power cord/extension cable of the rated length, use a cable drum with cable fully extended
	Power network is insufficient	Observe the electrical ratings of the machine and connect it only to a power network which complies with these ratings
	Drive motor no longer runs at rated speed (RPM)	Have the motor checked by a qualified electrician and replace if necessary
Insufficient flow of cooling water or no cooling water at all	The water pump draws air	Fill the water tray with water
	Filter clogged	Clean the filter of the water pump
	Pump wheel of the immersion pump is blocked by dirt	Disassemble the immersion pump and clean it

# OPERATION MANUAL

## HERE'S HOW TO GET HELP

PLEASE HAVE THE MODEL AND SERIAL  
NUMBER ON-HAND WHEN CALLING

### UNITED STATES

#### ***Multiquip Corporate Office***

18910 Wilmington Ave.  
Carson, CA 90746  
Contact: mq@multiquip.com

Tel: (800) 421-1244  
Fax (800) 537-3927

#### ***MQ Parts Department***

800-427-1244  
310-537-3700

Fax: 800-672-7877  
Fax: 310-637-3284

#### ***Service Department***

800-421-1244  
310-537-3700

Fax: 310-537-4259

#### ***Warranty Department***

800-421-1244  
310-537-3700

Fax: 310-943-2249

#### ***Technical Assistance***

800-478-1244

Fax: 310-943-2238

---

### MEXICO

#### ***MQ Cipsa***

Carr. Fed. Mexico-Puebla KM 126.5  
Momoxpan, Cholula, Puebla 72760 Mexico  
Contact: pmastretta@cipsa.com.mx

Tel: (52) 222-225-9900  
Fax: (52) 222-285-0420

### UNITED KINGDOM

#### ***Multiquip (UK) Limited Head Office***

Unit 2, Northpoint Industrial Estate,  
Globe Lane,  
Dukinfield, Cheshire SK16 4UJ  
Contact: sales@multiquip.co.uk

Tel: 0161 339 2223  
Fax: 0161 339 3226

### CANADA

#### ***Multiquip***

4110 Industriel Boul.  
Laval, Quebec, Canada H7L 6V3  
Contact: jmartin@multiquip.com

Tel: (450) 625-2244  
Tel: (877) 963-4411  
Fax: (450) 625-8664

© COPYRIGHT 2011, MULTIQUIP INC.

Multiquip Inc and the MQ logo are registered trademarks of Multiquip Inc. and may not be used, reproduced, or altered without written permission. All other trademarks are the property of their respective owners and used with permission.

This manual MUST accompany the equipment at all times. This manual is considered a permanent part of the equipment and should remain with the unit if resold.

The information and specifications included in this publication were in effect at the time of approval for printing. Illustrations, descriptions, references and technical data contained in this manual are for guidance only and may not be considered as binding. Multiquip Inc. reserves the right to discontinue or change specifications, design or the information published in this publication at any time without notice and without incurring any obligations.

Your Local Dealer is:





## Free Manuals Download Website

<http://myh66.com>

<http://usermanuals.us>

<http://www.somanuals.com>

<http://www.4manuals.cc>

<http://www.manual-lib.com>

<http://www.404manual.com>

<http://www.luxmanual.com>

<http://aubethermostatmanual.com>

Golf course search by state

<http://golfingnear.com>

Email search by domain

<http://emailbydomain.com>

Auto manuals search

<http://auto.somanuals.com>

TV manuals search

<http://tv.somanuals.com>