

OPERATION AND PARTS MANUAL



Submersible Pumps Model ST-1500 Series

Revision #0 (10/04/04)

**THIS MANUAL MUST ACCOMPANY
THE EQUIPMENT AT ALL TIMES.**

HERE'S HOW TO GET HELP

PLEASE HAVE THE MODEL AND SERIAL
NUMBER *ON-HAND* WHEN CALLING

MULTIQUIP CORPORATE OFFICE

18910 Wilmington Ave.
Carson, CA 90746
Email: mq@multiquip.com
Internet: www.multiquip.com

800-421-1244
FAX: 310-537-3927

PARTS DEPARTMENT

800-427-1244
310-537-3700

FAX: 800-672-7877
FAX: 310-637-3284

MAYCO PARTS

800-306-2926
310-537-3700

FAX: 800-672-7877
FAX: 310-637-3284

SERVICE DEPARTMENT

800-421-1244
310-537-3700

FAX: 310-537-4259

TECHNICAL ASSISTANCE

800-478-1244

FAX: 310-631-5032

WARRANTY DEPARTMENT

800-421-1244, EXT. 279
310-537-3700, EXT. 279

FAX: 310-537-1173

© COPYRIGHT 2004, Multiquip INC.

Multiquip Inc, the MQ logo are registered trademarks of Multiquip Inc. and may not be used, reproduced, or altered without written permission. All other trademarks are the property of their respective owners and used with permission.

This manual MUST accompany the equipment at all times. This manual is considered a permanent part of the equipment and should remain with the unit if resold.

The information and specifications included in this publication were in effect at the time of approval for printing. Illustrations are based on the *MQ Model ST-1500 Series Submersible Pumps*. Illustrations, descriptions, references and technical data contained in this manual are for guidance only and may not be considered as binding. Multiquip Inc. reserves the right to discontinue or change specifications, design or the information published in this publication at any time without notice and without incurring any obligations.

To find the latest revision of this
publication, visit our website at:
www.multiquip.com



ST-1500 SERIES SUB. PUMP — TABLE OF CONTENTS

Multiquip ST-1500 Series Submersible Pumps

Here's How To Get Help	2
Table Of Contents	3
Parts Ordering Procedures	4
Safety Message Alert Symbols	5
Rules For Safe Operation	6-7
Dimensions	8
Specifications (Pump/Control Box)	9
General Information	10
Components	11
Float Switches	12
Float Switch (Piggy-Back)	13
Float Switch (Control Box)	14
Operation	15
Control Box Installation	16-17
Clean-up	18
Maintenance	19
Troubleshooting (Pump).....	20
Performance Curves	21
Wiring Diagrams (Electric Motor/Control Box)	22
Explanation Of Codes In Remarks Column	24
Suggested Spare Parts	25

Submersible Pump Component Drawings

ST-1503A Pump Assembly	26-29
ST-1503CUL Assembly	30-33
ST-1503A/CUL Electric Motor Assembly	34-35

Terms and Condition of Sale — Parts	36
---	----

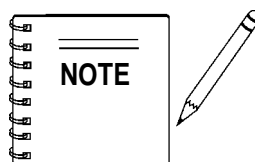

*As a continuing effort to update our parts book, contact the **MULTIQUIP literature department** for the latest revision of your "Operation and Parts Manual"*

ST-1500 SERIES SUB. PUMP — PARTS ORDERING PROCEDURES

When ordering parts,
please supply the following information:

- Dealer account number
- Dealer name and address
- Shipping address (if different than billing address)
- Return fax number
- Applicable model number
- Quantity, part number and description of each part
- Specify preferred method of shipment:
 - ✓ FedEx or UPS Ground
 - ✓ FedEx or UPS Second Day or Third Day
 - ✓ FedEx or UPS Next Day
 - ✓ Federal Express Priority One
 - ✓ DHL
 - ✓ Truck

Note: Unless otherwise indicated by customer, all orders are treated as "Standard Orders", and will ship within 24 hours. We will make every effort to ship "Air Shipments" the same day that the order is received, if prior to 2PM west coast time. "Stock Orders" must be so noted on fax or web forms.



Here's how to get help...

Please have the model and serial number on hand when calling.

MULTIQUIP CORPORATE OFFICE

18910 Wilmington Ave. 800-421-1244
 Carson, CA 90746 FAX: 310-537-3927
 Email: mq@multiquip.com
 Internet: www.multiquip.com

PARTS DEPARTMENT

800-427-1244 FAX: 800-672-7877
 310-537-3700 FAX: 310-637-3284

MAYCO PARTS

800-306-2926 FAX: 800-672-7877
 310-537-3700 FAX: 310-637-3284

SERVICE DEPARTMENT

800-421-1244 FAX: 310-537-4259
 310-537-3700

TECHNICAL ASSISTANCE

800-478-1244 FAX: 310-631-5032

WARRANTY DEPARTMENT

800-421-1244, EXT. 279 FAX: 310-537-1173
 310-537-3700, EXT. 279

Place Your Parts Order Via Web or Fax For Even More Savings!

Extra Discounts!

All parts orders which include complete part numbers and are received by our automated web parts order system, or by fax qualify for the following extra discounts:

Ordered via	Standard orders	Stock orders (\$750 list and above)
Fax	3%	10%
Web	5%	10%

Special freight allowances when you order 10 or more line items via Web or Fax! **

FedEx Ground Service **at no charge for freight**
 No other allowances on freight shipped by any other carrier.

NOTE: DISCOUNTS ARE SUBJECT TO CHANGE



MULTIQUIP INC.
 18910 WILMINGTON AVENUE
 POST OFFICE BOX 6254
 CARSON, CALIFORNIA 90749
 310-537-3700 • 800-421-1244
 FAX: 310-537-3927
 E-MAIL: mq@multiquip.com
 WWW: multiquip.com

**Direct TOLL-FREE access
to our Parts Department:**

Toll-free nationwide — 800-427-1244

ST-1500 SERIES SUB. PUMP — SAFETY MESSAGE ALERT SYMBOLS

FOR YOUR SAFETY AND THE SAFETY OF OTHERS!

Safety precautions should be followed at all times when operating this equipment. Failure to read and understand the Safety Messages and Operating Instructions could result in injury to yourself and others.

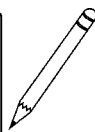
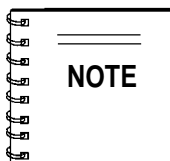

This Owner's Manual has been developed to provide complete instructions for the safe and efficient operation of the Multiquip **Model ST-1500 Series Submersible Pumps**. Before using these pumps, ensure that the operating individual has read and understands all instructions in this manual.

SAFETY MESSAGE ALERT SYMBOLS

The three (3) Safety Messages shown below will inform you about potential hazards that could injure you or others. The Safety Messages specifically address the level of exposure to the operator, and are preceded by one of three words: **DANGER**, **WARNING**, or **CAUTION**.

DANGER

You **WILL** be **KILLED** or **SERIOUSLY** injured if you **DO NOT** follow directions.

WARNING

You **CAN** be **KILLED** or **SERIOUSLY** injured if you **DO NOT** follow directions.

CAUTION

You **CAN** be **INJURED** if you **DO NOT** follow directions.

Potential hazards associated with the ST-1500 series submersible pumps operation will be referenced with Hazard Symbols which appear throughout this manual, and will be referenced in conjunction with Safety Message Alert Symbols.

HAZARD SYMBOLS



Rotating Parts



NEVER operate equipment with covers, or guards removed. Keep fingers, hands, hair and clothing away from all moving parts to prevent injury.



Accidental Starting



ALWAYS place the power source circuit breaker or ON/OFF switch in the **OFF** position, when the pump is not in use.



Sight and Hearing hazard

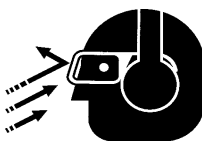

ALWAYS wear approved eye and hearing protection, if required.



Respiratory Hazard



ALWAYS wear approved respiratory protection, if required.



Equipment Damage Messages

Other important messages are provided throughout this manual to help prevent damage to your submersible pump, other property, or the surrounding environment.

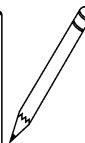
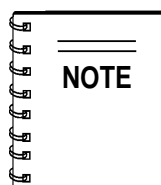

This submersible pump, other property, or the surrounding environment could be damaged if you do not follow instructions.

ST-1500 SERIES SUB. PUMP — RULES FOR SAFE OPERATION

CAUTION

Failure to follow instructions in this manual may lead to serious injury or even death! This equipment is to be operated by trained and qualified personnel only! This equipment is for industrial use only.

The following safety guidelines should always be used when operating the ST-1500 Series Submersible Pumps:

GENERAL SAFETY

- **DO NOT** operate or servicing this equipment before reading this entire manual.



- This equipment should not be operated by persons under 18 years of age.
- **NEVER** operate this equipment without proper protective clothing, shatterproof glasses, steel-toed boots and other protective devices required by the job.



- **NEVER** operate this equipment when not feeling well due to fatigue, illness or taking medicine.



- **NEVER** operate this equipment under the influence of drugs or alcohol.



- **NEVER** use accessories or attachments, which are not recommended by Multiquip for this equipment. Damage to the equipment and/or injury to user may result.
- Manufacturer does not assume responsibility for any accident due to equipment modifications.
- Whenever necessary, replace nameplate, operation and safety decals when they become difficult read.
- **ALWAYS** check the machine for loosened threads or bolts before starting.
- **NEVER** operate the submersible pump in an explosive atmosphere or near combustible materials. An explosion or fire could result causing severe **bodily harm or even death**.

- **ALWAYS** make sure submersible pump is grounded.
- **NEVER** use gas piping as an electrical ground.
- **DO NOT** place hands or fingers inside pump when pump is running.
- **ALWAYS** make certain that the voltage supplied to the pump is correct. Always read the pump's nameplate to determine what the power requirements are. The ST-1500 series submersible pumps require 115 VAC, 60 Hz (single-phase) for normal operation.
- **DO NOT** restrict the flow of the discharge hose as it may cause overheating.
- Be careful of discharge whipping under pressure.
- Make sure pump installation is accordance with national and local electrical codes.
- **ALWAYS** have a qualified electrician perform the pump wiring installation.
- **ALWAYS** mount the control box in a vertical position protected from the elements.
- **NEVER** handle pump's AC power cord with **wet hands**.
- **NEVER** let an extension cord or plug connection **lay in water**.
- **NEVER stand in water** while AC power cord is connected to a power source.
- **NEVER** use a pump with a defective, frayed power cord. Check the power cord on the pump for cuts in the insulation.
- **NEVER** use a extension cord that is frayed or damaged where the insulation has been cut.
- **ALWAYS** make certain that proper extension cord has been selected for the job. See Table 4.
- **NEVER** attempt to use the power cord as a lifting or lowering device for the submersible pump.
- When raising or lowering of the submersible pump is required, always attach an adequate rope or lifting device to the correct lifting point (handle) on the pump.
- **ALWAYS** place the pump in an upright position on a platform before using. The platform will prevent the pump from burrowing itself on soft sand or mud.
- **NEVER** operate pump on its side.
- **DO NOT** allow the pump to freeze in water.
- **NEVER** leave an open pump chamber unattended.
- The electrical voltage required to operate the pump can cause severe injury or even death through physical contact with live circuits. **ALWAYS** disconnect the electrical power from the pump before performing maintenance on the pump.

ST-1500 SERIES SUB. PUMP — RULES FOR SAFE OPERATION

- **ALWAYS** make sure that electrical circuits are properly *grounded* per the *National Electrical Code* (NEC) and local codes before operating pump. **Severe injury** or **death** by *electrocution* can result from operating an *ungrounded* pump.
- **NEVER** use this pump to remove water from a swimming pool when *people are in the water*.
- **ALWAYS** be sure the operator is familiar with proper safety precautions and operations techniques before using submersible pump.
- **ALWAYS** check pump oil level only when pump is cool. Expansion due to heat may cause hot! oil to spray from the oil plug when the oil plug is removed.
- **DO NOT** attempt to thaw-out a frozen pump by using a torch or other source of flame. Application of heat in this manner may heat the oil in the seal cavity above the critical point, causing pump damage.
- **DO NOT** pump water greater than 104° Fahrenheit. Also **DO NOT** pump liquids containing acid or alkali.
- **ALWAYS** check strainer before pumping. Make sure strainer is not clogged. Remove any large objects, dirt or debris from the strainer to prevent clogging.
- **ALWAYS** use a large basket strainer when pumping water that contain large debris.
- **ALWAYS** flush pump after use when pumping water concentrated with heavy debris. *Flush with clean fresh water*. It is very important to always flush the pump before turning it off to prevent clogging.
- **ALWAYS** store equipment properly when it is not being used. Equipment should be stored in a clean, dry location out of the reach of children.
- **ALWAYS** read, understand, and follow procedures in Operator's Manual before attempting to operate equipment.

Maintenance Safety

- **NEVER** lubricate components or attempt service on a running machine.
- **ALWAYS** allow the machine a proper amount of time to cool before servicing.
- Keep the machinery in proper running condition.
- Fix damage to the machine immediately and always replace broken parts.

Emergencies

- **ALWAYS** know the location of the nearest *fire extinguisher*.



- **ALWAYS** know the location of the nearest *first aid kit*.



- In emergencies *always* know the location of the nearest phone or *keep a phone on the job site*. Also know the phone numbers of the nearest *ambulance, doctor* and *fire department*. This information will be invaluable in the case of an emergency.

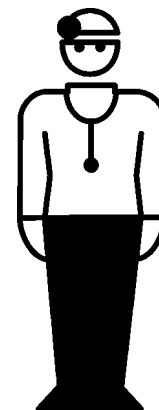
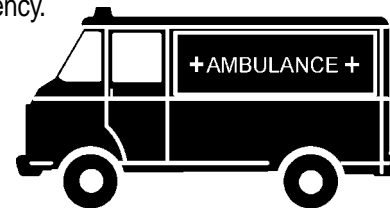

ST-1500 SERIES SUB. PUMP — DIMENSIONS

ST-1503A, AND CUL

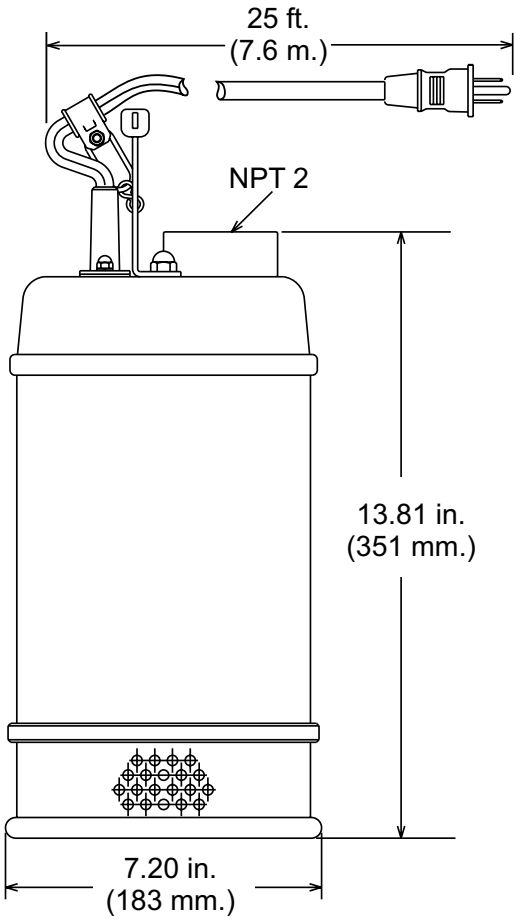

Figure 1. ST-1503A, CUL Dimensions

ST-1500 SERIES SUB. PUMP — SPECIFICATIONS

TABLE 1. SPECIFICATIONS

Model	ST-1503A	ST-1503CUL
Type	Submersible Trash Pump	Centrifugal Submersible Pump
Impeller	Cast Iron Ductile	Cast Iron Ductile
Suction & Discharge Size	2.00 in. (51 mm)	1.50 in. (38 mm)
Maximum Pumping Capacity	72 gallons/minute (273 liters/minute)	45 gallons/minute (170 liters/minute)
Max. Solids Diameter	1.00 in. (25 mm.)	N/A
Max Head	34 ft. (10.3 meters)	28 ft (8.5 meters)
Power	0.5 HP (0.37kw)	0.33 HP (0.25kw)
Voltage Phase	1Ø 115V	1Ø 115V
Starting Amps	25	42
Running Amps	6.2	6
Control Box Required	NO (Note 3)	NO (Note 3)
Thermal Overload Protection	YES	YES
Rotation	CCW (Note 1)	CCW (Note 1)
Mechanical Oil seal Capacity	180 cc. (Note 2)	150 cc. (Note 2)
Check Frequency	Monthly (300 hrs.)	Monthly (300 hrs.)
RMP (Speed)	3550 ± 30	3550 ± 30
Power Cable Length	25 ft. (7.6 cm.)	25 ft. (7.6 cm.)
Dry Net weight	33 lbs. (15 Kg.)	38 lbs. (17 Kg.)

1. **Motor Rotation** – Upon start-up, the pump "**kicks**" in the opposite direction of motor rotation. The correct rotation is counterclockwise (CCW) as viewed from the impeller end of the pump.
2. **Mechanical Oil Seal** – Use a good grade 10 weight non-detergent hydraulic oil (i.e. Shell Turbo 32 or equivalent). Fill oil cavity 75% to 85% full (allow air space for expansion).
3. **Control Box** - Control box (Table 2) may be required for certain pumping applications.

Table 2. Control Box Specifications

Model No.	VoltageType	UL/CSA Listed	Thermal Overload Protection	Float Switch Capability
CB3	115 VAC, 60 Hz Single-Phase	YES	NO	YES

ST-1500 SERIES SUB. PUMP — GENERAL INFORMATION

Introduction

The Multiquip Model ST-1500 series submersible pumps are designed to pump water and is used for the draining (de-watering) of swimming pools, well casings construction sites, cofferdams, manholes, transformer vaults and excavations.

A cast iron ductile type impeller is attached to the output shaft of a 0.5 HP (ST-1503A) or 0.3 HP (ST-1503CUL) electric motor which provides adequate power for general purpose pumping. This submersible pump is supplied complete with an electric power cable, and a discharge port which accepts a 2-inch (ST-1503A) or 1.5-inch (ST-1503CUL) hose.

This pump is ideal for portability because of its light weight and carrying handle. For reliability and long life, a mechanical seal provides shaft sealing, with an oil chamber separating the pump section from the motor.

The pump when in use, should be installed as free standing (upright position) on its strainer base. A discharge hose (not supplied) should be connected to the discharge port. The discharge hose should be adequately supported to avoid stress on the pump.

For maximum water flow, the discharge hose should be kept as short as possible, and with minimum elevation above the pump. Remember as the length and/or height of the discharge hose is increased, the flow of water will be reduced. Also any reduction in the hose size, and any fittings such as valves or outlet nozzles, will restrict the water flow.

To avoid back-siphonage when the pump is switched off, ensure that the end of the discharge hose is installed above the water level at the final discharge point.

When the pump is switched off, the water remaining in the hose will run back through the pump. This can be avoided by placing a non-return valve in the hose nearest the pump.

NEVER use this submersible pump to pump flammable liquids or operate in a explosive or flammable environment.

Avoid using this pump in conditions where mud, grit, silt or other debris are present. These conditions could cause blockage and cause excessive pump wear.

DO NOT install the pump directly into an area where there is a heavy buildup of mud, grit, silt or debris. If this condition is present, install the pump on a platform before operating.

This pump must always be positioned on a platform in an upright position. **NEVER** operate the pump by a suspended rope. To prevent large solids from entering the pump, install a wire mesh screen or similar barrier around the pump.

If the pump was used to pump water containing mud, silt, use clean water to flush out the pump after each use.

DO NOT allow the pump to run dry, as this will damage the pump. During maintenance, dry running is permissible but only for a few seconds.



NEVER lift the pump by its electrical power cord. **ALWAYS** lift the pump by its carrying handle or attach a rope to the carrying handle.

A pump fully submerged pump in liquid will not freeze, unless the liquid freezes. **DO NOT** allow a partially submerged pump to freeze. The expansion of water freezing in the volute may crack the pump, causing expensive repairs. If there is any danger of the pump being subjected to freezing temperatures, lift the pump from water and allow it to drain thoroughly.



If the pump jams or the pump rotor locks for any reason, disconnect the pump from the power source immediately. Allowing the pump motor to cycle **ON** and **OFF** under an overload condition can burn out the motor.

When replacement of nuts and bolts is required, use only recommended parts as referenced in the parts section of this manual. This pump uses **metric** threads. **DO NOT** use English measurement threads.

Control Box Installation Warnings

**DANGER**

When installing the CB3 control box, the possibility exists of **electrical shock**, **electrocution** and possibly **death!** **NEVER** have untrained personnel perform the installation. **ALWAYS** have qualified service personnel (licensed electrician) perform the installation.

**WARNING**

Explosion or Fire Hazard exists if this pump is used with **flammable liquids**. **DO NOT** use this pump with **flammable liquids**. **DO NOT** install this pump in hazardous locations as defined by the National Electrical Code, ANSI/NFPA 70.

Failure to follow the above referenced precautions could result in serious injury or death! Replace pump cord immediately if cord becomes damaged or severed. This pump must be installed in accordance with National Electric Code ANSI/NFPA 70 so as to prevent moisture from entering or accumulating with the boxes, conduit bodies fittings, float housing or cable.

ST-1500 SERIES SUB. PUMP — COMPONENTS

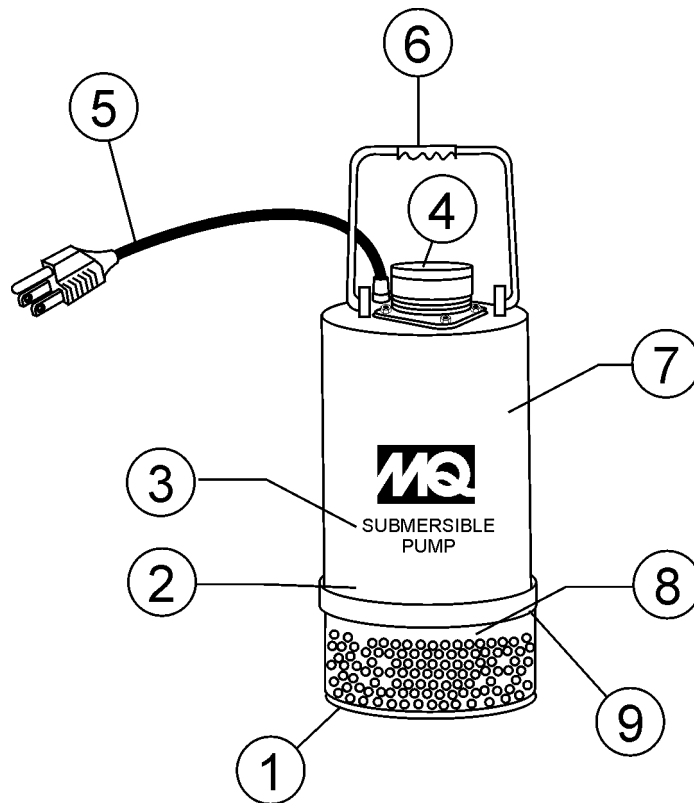

Figure 2. Submersible Pump Components

Figure 2 shows the location of the basic components, for the ST-1500 series submersible pumps. Listed below is a brief explanation of each component.

- 1. Strainer Base** – This strainer base is made of stainless steel which is resistant to hardware corrosion. **DO NOT** pump large objects or debris with this pump. This pump is for pumping water only. For de-watering purposes, always place the strainer base on a platform.
- 2. Volute/Impeller** – Impellers are constructed of high-chrome ductile iron to minimize wear and prolong service life.
- 3. Electric Motor** – The ST-1503A submersible pump utilizes a 60 Hz, single-phase, 115 VAC, 0.5 HP electric motor. The ST-1503CUL submersible pump utilizes a 60 Hz, single-phase, 115 VAC, 0.33 HP electric motor. Consult with a **licensed electrician** before connecting motor to a power source. Observe all city and local safety codes.
- 4. Discharge Port** – Connect a 2-inch (ST-1503A) or 1.5-inch (ST-1503CUL) hose to this port. Remember to adequately support the discharge hose to avoid stress on the pump.
- 5. AC Power Cable** – This unit is supplied with a 25 ft. (7.6 meters) AC power cable. Always check the cable for signs of wear. **NEVER!** use a defective power cable. Replace the cable immediately if the cable is worn or defective.
- 6. Carrying Handle** – Always carry the submersible pump by its handle. **NEVER!** carry the pump by its power cord. Carrying or lifting the pump by the power cord, will cause undue stress on the cord, and ultimately the cord will become dislodged from the pump.
- 7. Thermal Overload Protection** – This pump is equipped with a thermal overload protection device that will shutdown the motor in the event of high operating temperatures. The motor will automatically restart once the temperature returns to an acceptable operating temperature.
- 8. Mechanical Oil Seal** – This oil filled seal provides lubrication when running the pump dry. **NEVER!** run the pump dry. Running the pump dry will cause severe damage to the pump.
- 9. Mechanical Oil Seal Plug** – Remove this plug to check and add hydraulic oil (Shell 32 or equivalent) to the oil cavity. This oil protects the mechanical seal. Oil cavity should be full enough to cover seal spring.

ST-1500 SERIES SUB. PUMP — FLOAT SWITCHES

Float Switch Theory

Mercury monitoring is a mercury-switch actuated, liquid level control that has proven to be more economical and longer lasting than other types of liquid-level control systems, easily replacing and improving upon diaphragm switches, air bubble systems and electromechanical switches most often relied upon in the past.

How It Works

There is a tilt-sensitive mercury switch hermetically sealed within each float. As the liquid level (water) rises or falls, the float changes its angle until the mercury switch makes (closed, Figure 4) or breaks (open, Figure 5) the circuit. Maximum pumping range is 120 degrees. See Figure 3 below.

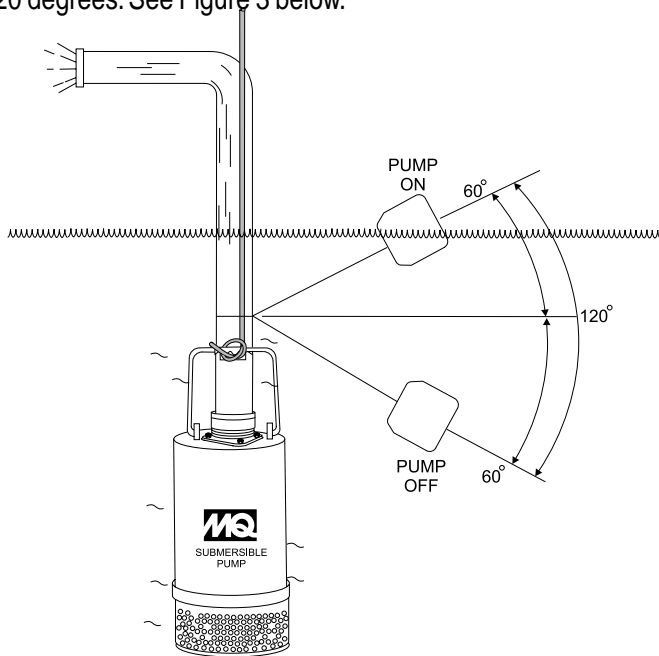

Figure 3. Pumping Range (Float Switch)

Pumping Range

The pumping range of the pump is determined by the float switch tether cord. Use Table 3 as guide line to determine your required pumping range. Pumping ranges are based on **non-turbulent** conditions. Range may vary due to water temperature and cord shape. Please note as the tether length increases, so does the variance of the pumping range.

Table 3. Pumping Range

Tether Length	2 in. 5.08 cm.	4 in. 10.16 cm.	6 in. 15.24 cm.	8 in. 20.32 cm.	10 in. 25.4 cm.	12 in. 30.48 cm.	14 in. 35.56 cm.	16 in. 40.64 cm.
Pumping Range	6 in. 15.24 cm.	10 in. 25.4 cm.	14 in. 35.56 cm.	18 in. 45.72 cm.	22 in. 55.88 cm.	27 in. 68.58 cm.	31 in. 78.74 cm.	35 in. 88.9 cm.

Design Features

Constructed of rigid, durable ABS polymer ultrasonically welded. The all-steel mercury switch is held by positioning pins. Interior is filled with cell foam.

- Suitable for most liquid environments.
- Hermetically sealed.
- Thick-walled non-corrosive PVC plastic enclosure.
- Pressure tested to 60 ft. (18.2 meters).
- Mercury switch reliability, proven to 500,000 cycles.
- Standard SJO, 16-gauge, 2 conductor cord (20 ft./6.09 m).

Pump Down / ON POSITION

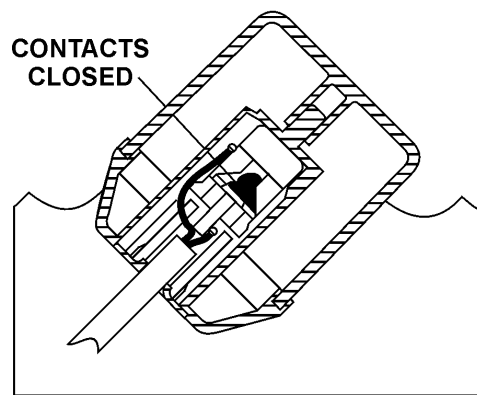

Figure 4. Float Switch (Closed)

Pump Down / OFF POSITION

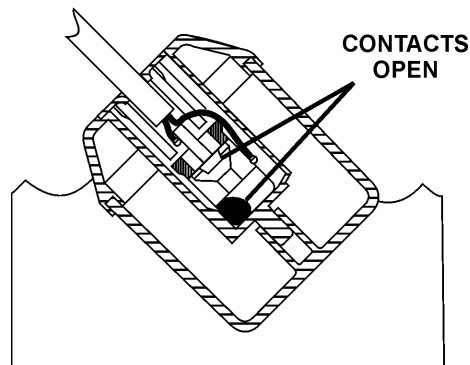

Figure 5. Float Switch (Open)

ST-1500 SERIES SUB. PUMP — FLOAT SWITCH (PIGGY-BACK)

Float Switch

Single or **dual** control float switches can be used for the unattended operation of the submersible pump. When using the **piggy-back power configuration** (plug), the ST-1500 series pumps **DO NOT** require the use of a control box. In this configuration (piggy-back), the SW-1 (single float switch) or SW-2 (dual float switch) are required. Figure 6 is an example of a single float switch application.

Mounting The Float Switch

1. Determine the required **cord tether length** as shown in Figure 6 and Table 3.
2. Place the cord into the clamp as shown in Figure 6.
3. Secure the clamp to the discharge hose as shown in Figure 5. **DO NOT** install cord under hose clamp.
4. Using a screwdriver, tighten the hose clamp. **DO NOT** over-tighten. Make sure the float cord is not allowed to touch the excess hose clamp band during operation.

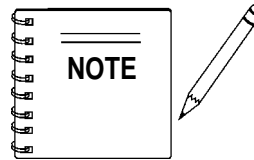

Figure 6 shows a **single float** switch application. For dual float switch capability use a **Model SW-2** mercury type float switch.

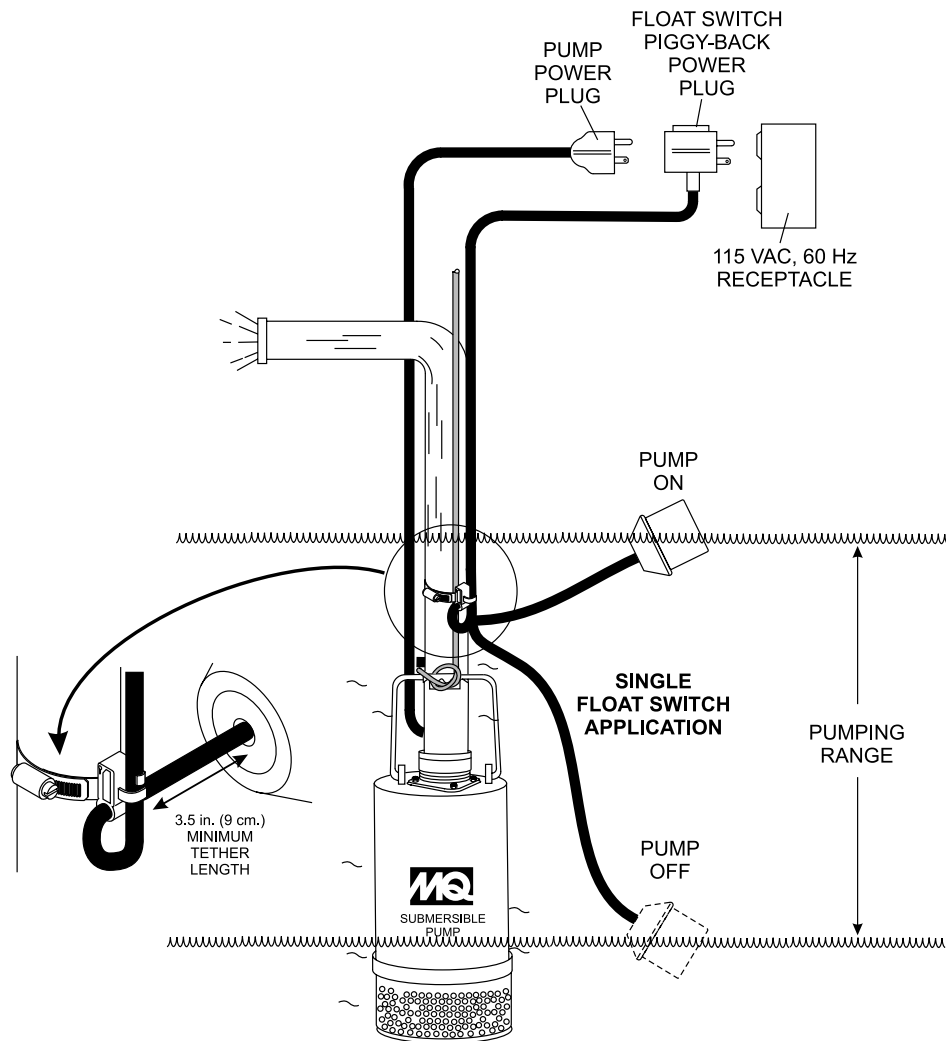
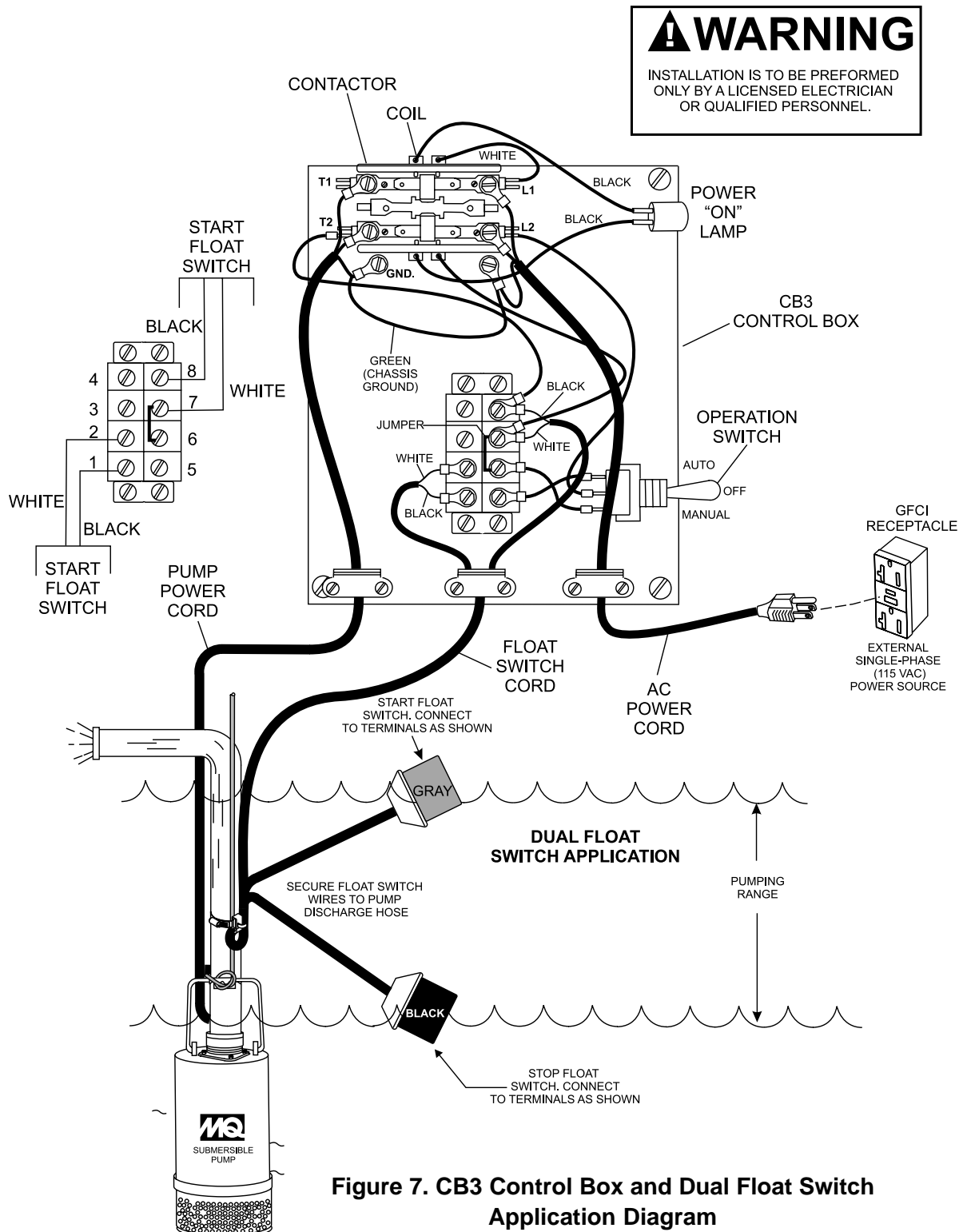

Figure 6. Single Float Switch Application Diagram

ST-1500 SERIES SUB. PUMP — FLOAT SWITCH (CONTROL BOX)

Control Box (CB3)

For special remote pumping applications of the submersible pump, a control box (**Model CB3**) may be required. This water resistant control box provides watertight housing and glands to prevent water from leaking into the box, and a float switch interface. When using the CB3 control box, only the **SW-1WOP float switch (2)** can be used (no plug, bare wires). Shown below (Figure 7) is a wiring layout of the CB3 control box. See page 22 for a wiring diagram of the control box.



ST-1500 SERIES SUB. PUMP — OPERATION

Hose Connections

1. Connect a 2-inch (ST-1503A) or 1.5-inch (ST-1503CUL) hose to the discharge port on the pump as shown in Figure 8. Make sure that the hose is attached correctly to the discharge port.

Pump Power Connections (Piggy-Back Cord Only)

1. Make sure the circuit breaker supplying power to the pump is in the **OFF** position.
2. Connect the float switch or switches to the AC power receptacle as shown in Figure 6.

Attaching Lifting Rope

1. Attach a suitable lifting cable (rope) to the carrying handle (Figure 8) on the pump and lower the pump into place. For applications where there is an excessive amount of mud, grit or silt, the use of a support platform is desirable. When pumping water from swimming pool type applications where there is little or no debris, the support platform is not required.

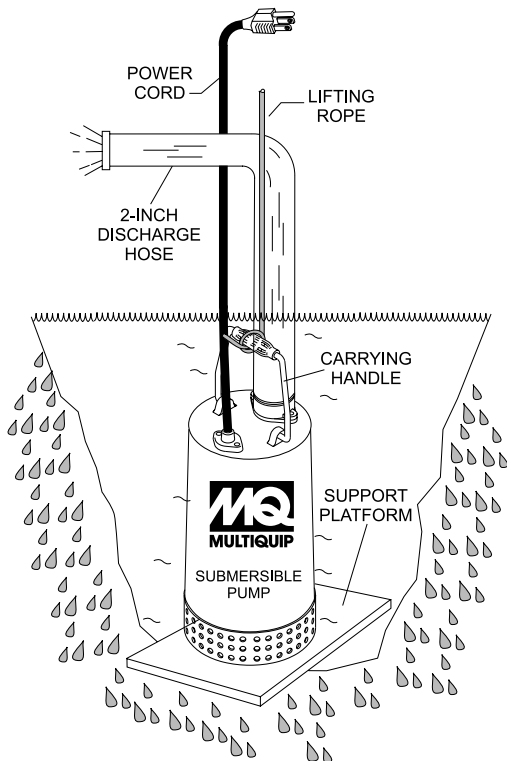

Figure 8. Submersible Pump Upright Position (Correct)

2. Make sure the pump is always placed in an upright position, not tilted (Figure 9). Never position the pump directly on a soft, loose bottom. Remember to attain maximum pumping capacity and prevent excessive wear, position the pump so it will not burrow itself into sand or clay.

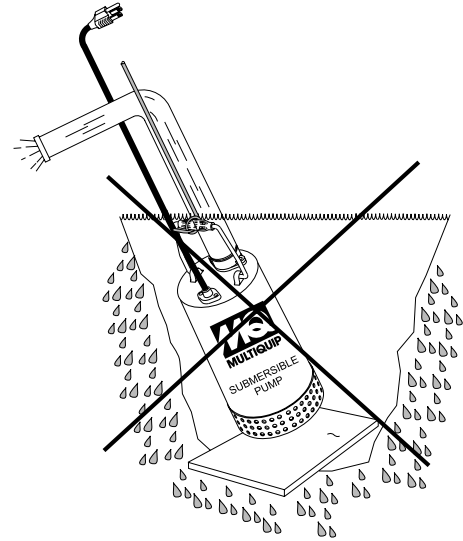

Figure 9. Submersible Pump Upright Position (Incorrect)

3. If all of the pump's electrical requirements have been met, place the **circuit breaker** or power **ON/OFF** switch in the **ON** position.
4. Wait a few seconds and water should begin to flow from the discharge hose.
5. If water is not flowing from the discharge hose or not flowing freely after a few minutes, remove the power from the pump and check the system for leaks.
6. To stop the pump from pumping, place the **circuit breaker** or **ON/OFF** switch in the **OFF** position.

! DANGER

NEVER! grab or touch a live power cord (Figure 10). **DO NOT** stand in water when connecting the pump's power cord into a voltage source. The possibility exist of **electrical shock**, **electrocution** and possibly **death!**

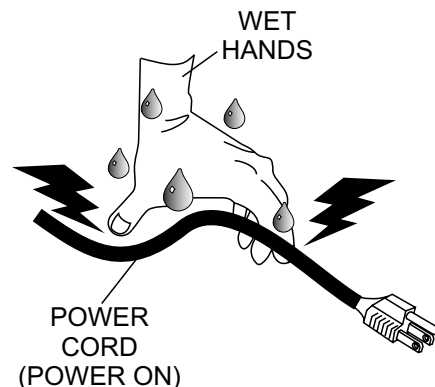

Figure 10. Power Cord (Wet Hands)

ST-1500 SERIES SUB. PUMP— CONTROL BOX INSTALLATION

DANGER

The ST-1500 series submersible pumps are also designed to work with a control box (**Model CB3**). This control box contains the necessary electronics (float switch connections) to operate the pump. Remember this control box contains hazardous voltages. Disconnect all sources of power before installing or servicing. There exists the possibility of electrocution, electric shock or burn, which can cause severe bodily harm or even **death!**



CAUTION

This control box should only be installed or serviced by a **licensed electrician or qualified personnel.**

Control Box Mounting

Mount the control box in an **upright vertical position**. Make sure the control box is securely fastened to a flat surface, that is free of dust, dirt, moisture or any elements that may contaminate or erode the electronic components of the control box.

Single-Phase Power Installation (Input)

All ST-1500 series submersible pumps require 115 V, 60 Hz., single-phase power for **normal operation**.

If you cannot determine what your pump's power requirements are, look at the vendor supplied identification name tag attached to the pump or please contact Multiquip's Service/Technical Assistance department.

CAUTION

Applying incorrect power (**voltage phasing**) to the submersible pump can cause severe damage to the pump. Please make sure that the correct voltage and phase are transferred to the pump at all times.

Power Cord Requirements

When routing the 115 VAC, 60 Hz., single phase power via a power cord to the control box, **ALWAYS** use the correct wire size. Please reference Table 4 below (Cord Length/Wire Size) to determine the correct wire size. Incorrect wire size can adversely affect the performance of the pump.

TABLE 4. CORD LENGTH AND WIRE SIZE

AMPS	50 FT.	100 FT.	150 FT.
6	16 AWG	16 AWG	14 AWG
8	16 AWG	14 AWG	12 AWG
10	16 AWG	14 AWG	12 AWG
12	14 AWG	14 AWG	12 AWG
14	14 AWG	12 AWG	10 AWG
16	12 AWG	12 AWG	10 AWG

Connecting Dual float Switch (SW-1WOP) To Control Box

1. Remove the float switch input connector housing, then route the float switch wires through the cable gland on the control box. Attach the wires of the float switch to the terminal block as indicated by Table 5 and Figure 6.

TABLE 5. FLOAT SWITCH CONNECTIONS

FLOAT SWITCH	TERMINAL BLOCK NUMBER
START	TERMINAL 1 (BLACK) TERMINAL 2 (WHITE)
STOP	TERMINAL 7 (WHITE) TERMINAL 8 (BLACK)

2. Tighten the connector housing to ensure a tight fit between the cord and the connector body. This will prevent the cable from pulling out of the terminal block and also prevent moisture from entering the control box.
3. Determine the length of the float switch wires, then secure float switch wires to pump discharge hose. See Figures 3 and 6 and Table 3 to determine the pumping range.

ST-1500 SERIES SUB. PUMP— CONTROL BOX INSTALLATION

Connecting AC Power to the Control Box

1. The AC power cord (input) should have three wires. Each wire is color coded. The colors are **WHITE, BLACK** and **GREEN**.
2. Remove the AC input connector housing from the control box, then route the power cord through the cable gland on the control box.
3. Connect the AC power cord to the contactor as shown in Figure 7 and Table 6.

CABLE WIRE COLOR	CONTACTOR
BLACK	L1
WHITE	L2
GREEN	GROUND

4. Tighten the connector housing to ensure a tight fit between the power cord and the connector body. This will prevent the cable from pulling out of the terminal block and also prevent moisture from entering the control box.

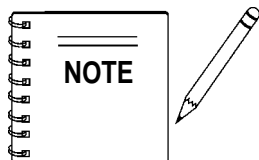

It is recommended that the power being supplied to the control box **ALWAYS** be connected to a **circuit breaker** or a **quick disconnect** switch. This safety feature allows for quick removal of power from the control box in the event of an emergency.

5. Connect the other end of the AC power cord to the voltage source. Remember to provide a means of disconnecting the power from the control box (circuit breaker or quick disconnect switch). Also make sure to provide a good earth ground to the control box.

Connecting AC Power to the Pump

1. AC power is transferred to the pump via a contactor. The coil of the contactor is energized or de-energized by the opening and closing of the float switch contacts. The power cord should have three wires. Each wire is color coded. The colors are **WHITE, BLACK** and **GREEN**.

2. Remove the pump AC input connector housing from the control box, then route the power cord through the cable gland on the control box.
3. Connect the pump power cord to the contactor as shown in Figure 7 and Table 7.

CABLE WIRE COLOR	CONTACTOR
BLACK	T1
WHITE	T2
GREEN	GROUND

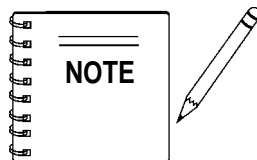

Electrical connections to the power source should only be performed by a **licensed electrician** or **qualified personnel**.

Turning On The Pump

1. If all of the pump's electrical requirements have been met, place the **circuit breaker** or power **ON/OFF** switch in the **ON** position.
2. The CB3 control box has an **operation switch** located on the front cover. This switch has 3 positions, **AUTO, MANUAL** and **OFF**. The **AUTO** position allows the pump to run in an unattended mode. The **MANUAL** position will let the pump run without the float switches controlling the pump. When in the manual mode be careful not to let the pump run dry. Severe damage to the pump may occur if it is allowed to run dry. **NEVER** let the pump **run dry**.
3. Place the operation switch in the **AUTO** position. The AC power indicator lamp should be lit (**ON**).
4. Wait a few seconds and water should begin to flow from the discharge hose.
5. If water is not flowing from the discharge hose or not flowing freely after a few minutes, remove the power from the pump and check the system for leaks.
6. To stop the pump from pumping, place the operation switch in the **OFF** position.

Pump Shut-Down/Clean-up

1. Remove the power from the pump by turning off the circuit breaker or switch that provides power to the pump. Remember to make sure that hands are dry (not wet), and feet are not standing in water when removing disconnecting power from the pump.
2. Using the lifting rope, lift the pump up from its current position. Remove the discharge hose from the discharge port on the pump.
3. Remove all power cables and float switches from the control box. Place cables and float switches in a suitable container where they will not get damaged.
4. If the pump was used to pump mud, grit or silt, flush vigorously with clean water.
5. Remove the pump from the water. Wipe off any mud or debris that might have attached itself to the pump.
6. Store pump in a clean dry place away from dirt and debris.

ST-1500 SERIES SUB. PUMP — MAINTENANCE

LUBRICATION

To check the oil level of the mechanical seal, perform the following:

1. Lay the pump (Figure 11) on its side with the oil plug facing upwards.
2. Remove oil fill plug.
3. Visually inspect oil plug hole to verify that oil cavity is full enough to cover seal spring. Check every 300 hours, change hydraulic oil every 6 months (1,000 hours) or as needed.
4. While checking the hydraulic oil level, also check the condition of the hydraulic oil in the seal cavity. Block the opening with a finger and roll pump to one side to drain oil into a small transparent container. If oil is cloudy or has water in it, drain oil from pump cavity and replace hydraulic oil. Check the seal for wear damage.

5. If oil level is low fill with SAE 10 weight non-detergent hydraulic oil (i.e. Shell Turbo 32 or equivalent). Fill oil cavity 75% to 85% full (allow air space for expansion). See Table 1 for pump oil cavity capacity.

IMPELLER

1. Make sure the clearance between the impeller and the friction disk is approximately .012 - .020 inches (.304 - .508 mm.)
2. If impeller is defective or badly worn, replace impeller immediately.

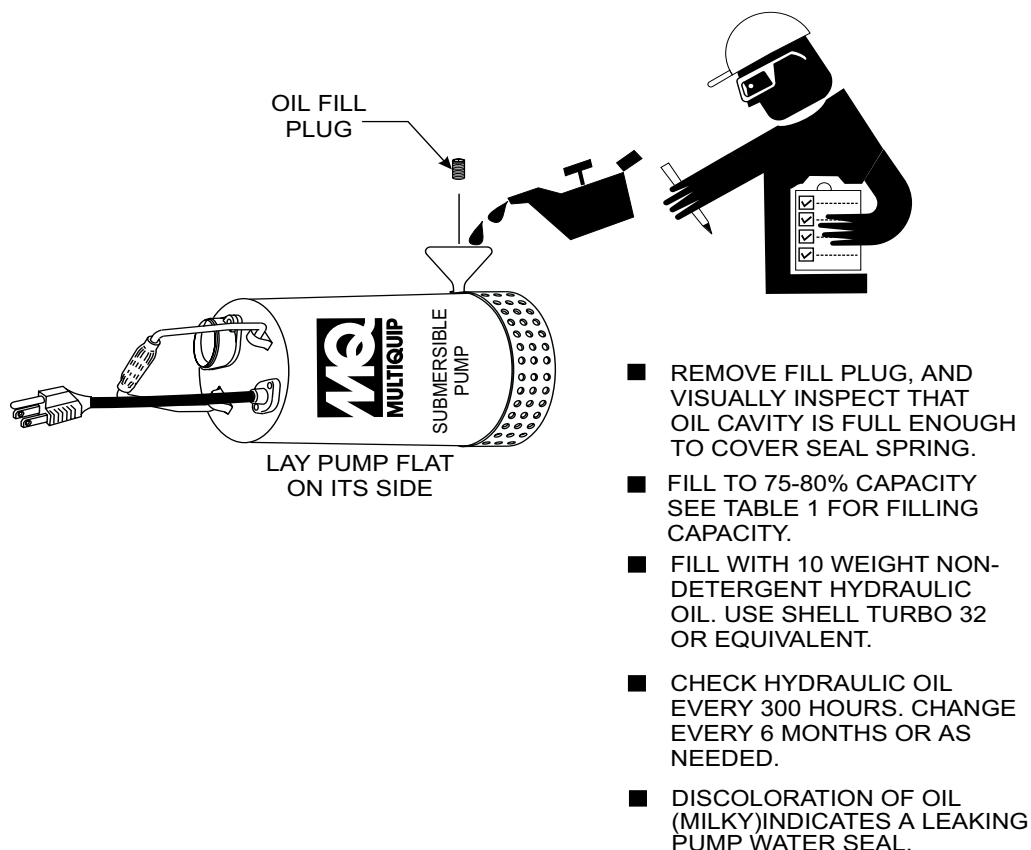

Figure 11. Checking Hydraulic Oil

ST-1500 SERIES SUB. PUMP — TROUBLESHOOTING

Practically all breakdowns can be prevented by proper handling and maintenance inspections, but in the event of a breakdown, use Table 8 (Pump Troubleshooting) as a basic guideline for troubleshooting the pump. If the problem cannot be remedied, contact Multiquip's service department.

TABLE 8. PUMP TROUBLESHOOTING

SYMPTOM	POSSIBLE PROBLEM	SOLUTION
Pump Fails To Start	Incorrect voltage/amps?	Check that proper voltage (115 VAC, 60 Hz, single-phase) is being supplied to the pump. Also check that there is an adequate amount of current (amps) to run the pump. Check power source circuit breaker.
	Check electrical connections?	If using float switches check wiring, inspect power cord.
	Blown power fuse?	Replace fuse, check cause of blown fuse.
	Impeller locked?	Disconnect power cord and check for clogging and improper impeller clearance. Unclog pump. Check overload protection device.
	Wet motor windings?	Use multimeter to check motor insulation. Insulation resistance must be approximately 15 megaohms. If resistance is low, disassemble pump motor and bake windings to dry them.
	Defective motor and pump bearings?	Check for excessive bearing wear, if worn replace bearings. Replace motor if defective.
Pump Fails to Deliver Full Output	Twisted or restricted discharge hose?	Lay hose flat un-kinked. Remove clog from hose line.
	Clogged pump strainer?	Clean strainer.
	Low voltage?	Use a voltmeter to check voltage while pump is energized. Voltage must be within $\pm 10\%$. Check power source (no load and load). If an extension cord is used, make sure it has adequate current-carrying capacity for the required length. See Table 4.
	Impeller worn?	Replace impeller.
Water in Seal Oil	Defective water seal?	Replace water seal.
	Loose Oil Fill Plug?	Tighten securely.

ST-1500 SERIES SUB. PUMP — PERFORMANCE CURVES

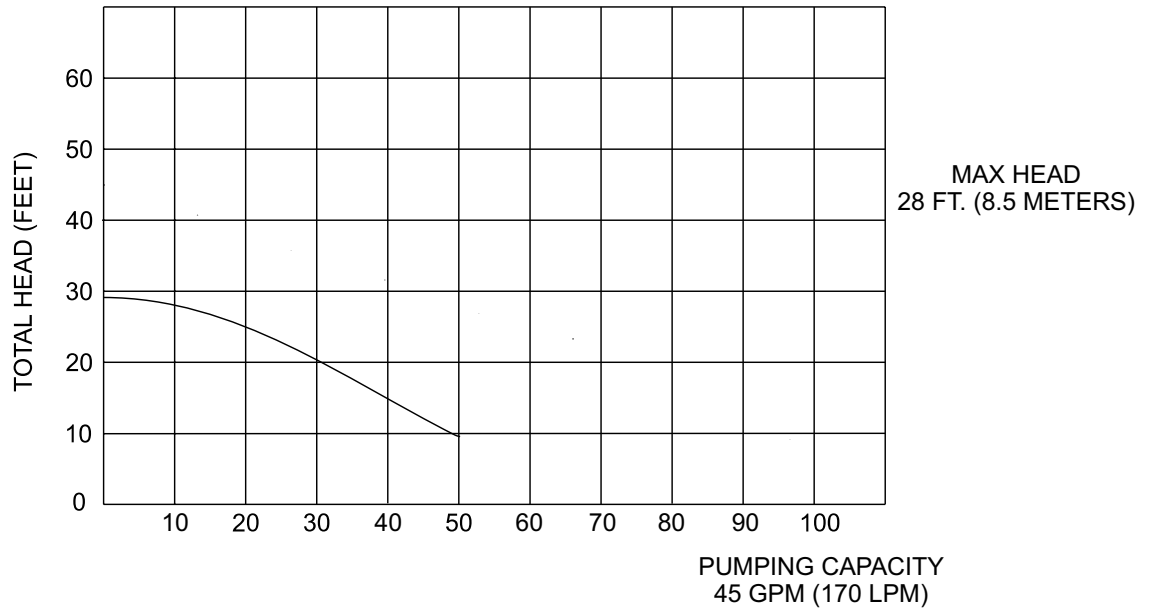
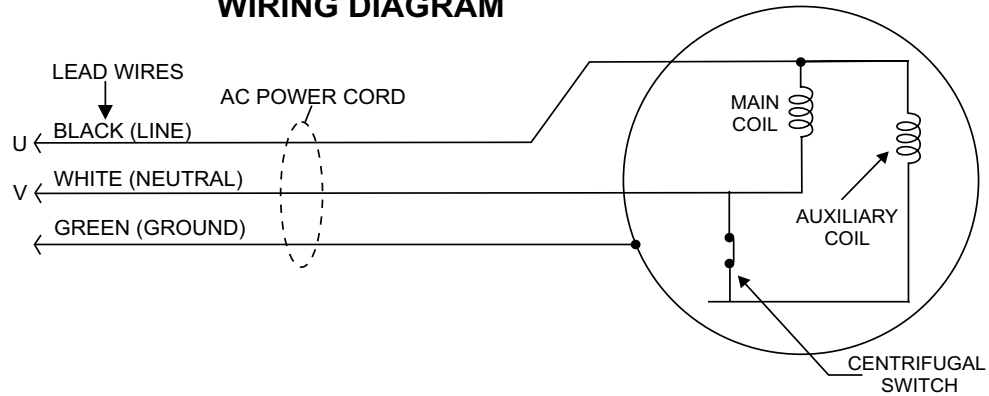

Figure 12. Pump Performance Curves

ST-1500 SERIES SUB. PUMP — WIRING DIAGRAMS

115 VAC, 60 Hz. ELECTRIC MOTOR WIRING DIAGRAM



CONTROL BOX WIRING DIAGRAM

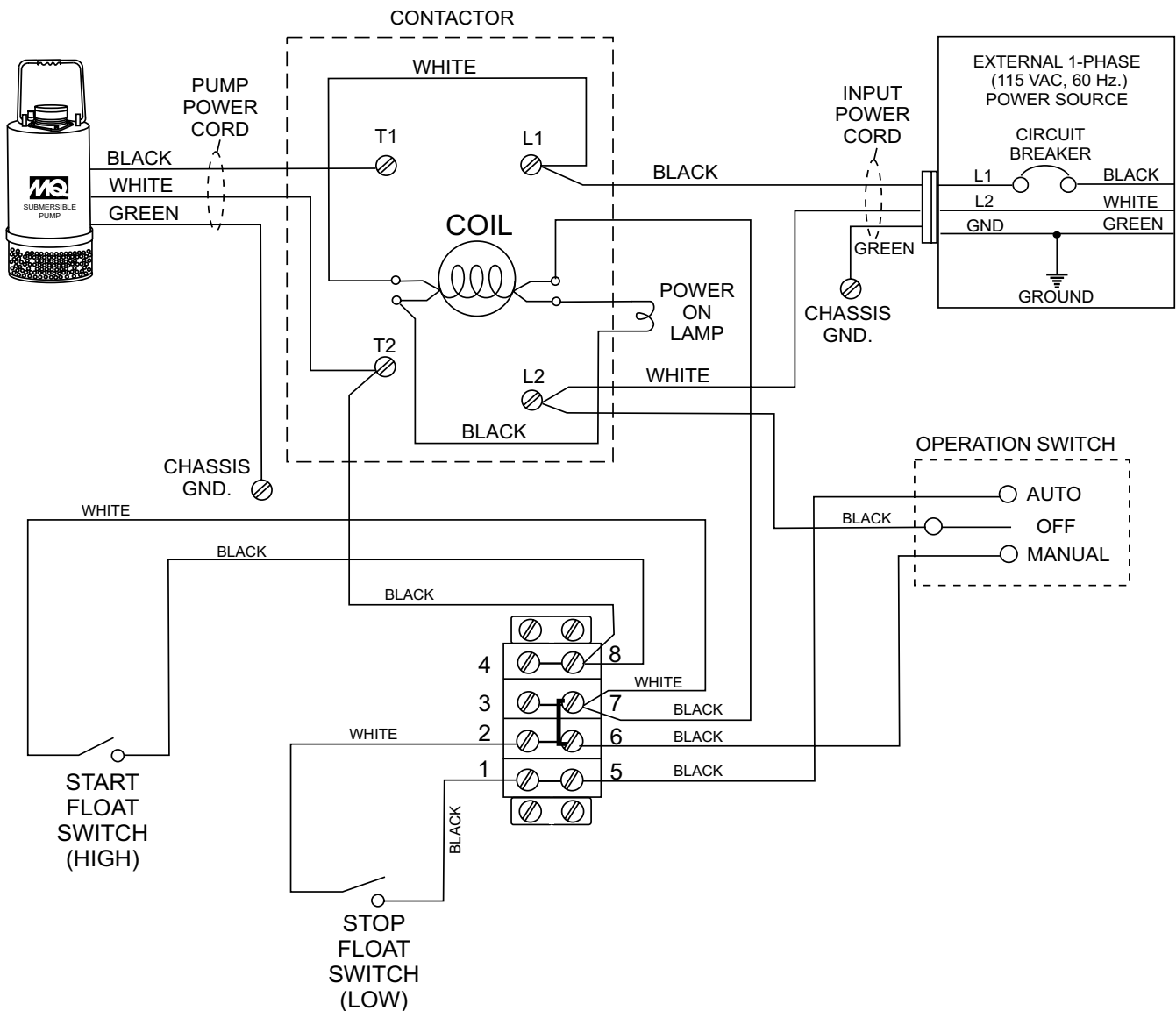

ST-1500 SERIES SUB. PUMP — EXPLANATION OF CODE IN REMARKS

How to read the marks and remarks used in this parts book.

Items Found In the “Remarks” Column

Serial Numbers-Where indicated, this indicates a serial number range (inclusive) where a particular part is used.

Model Number-Where indicated, this shows that the corresponding part is utilized only with this specific model number or model number variant.

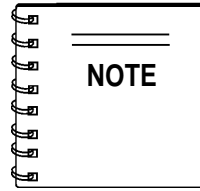

The contents of this parts catalog are subject to change without notice.

Items Found In the “Items Number” Column

All parts with same symbol in the number column, *, #, +, %, or >, belong to the same assembly or kit.

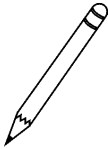
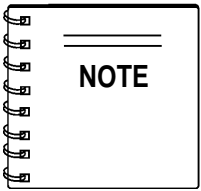

If more than one of the same reference number is listed, the last one listed indicates newest (or latest) part available.

ST-1500 SERIES SUB. PUMP — SUGGESTED SPARE PARTS

ST-1503A/CUL SUBMERSIBLE PUMP 1 TO 3 UNITS

Qty.	P/N	Description	Remarks
1	0201503A120	AC CORD W/ GLAND	ST-1503A
1	0201503UL120	AC CORD W/ GLAND	ST-1503CUL
1	0201503A081	OIL SEAL	ST-1503A
1	0201503081	OIL SEAL	ST-1503CUL
1	0201503A112	OIL SEAL	
1	0201503A008	PACKING, CASING	ST-1503A
1	0201503UL008	PACKING, CASING	ST-1503CUL
1	0201503A060	MECHANICAL SEAL	ST-1503A
1	0201503060	MECHANICAL SEAL	ST-1503CUL
1	0201503A003	IMPELLER	ST-1503A
1	0201503003	IMPELLER	ST-1503CUL

ST-1503A — ELECTRIC SUBMERSIBLE PUMP ASSY.

ST-1503A - ELECTRIC SUBMERSIBLE PUMP ASSY.

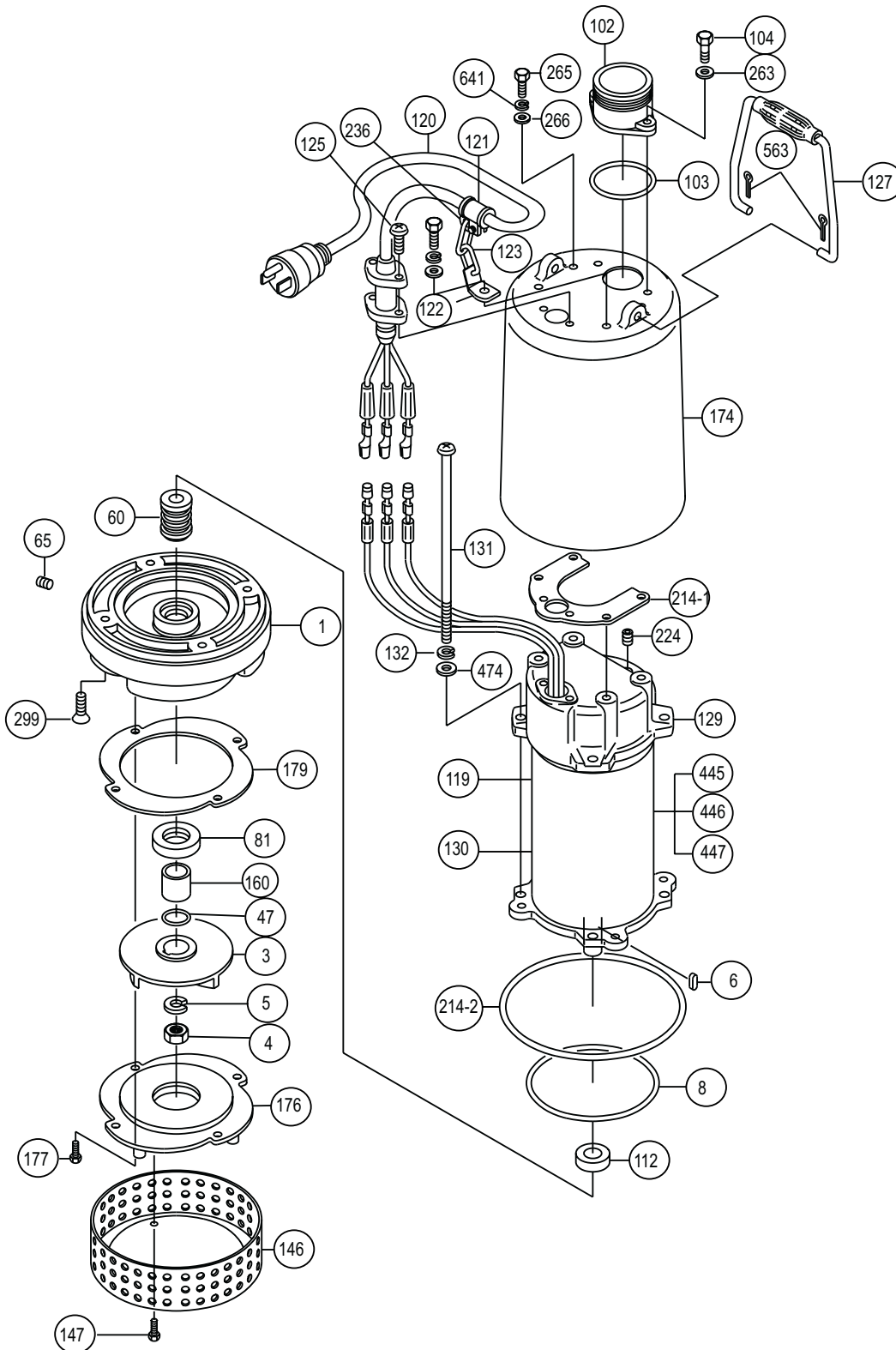

ST-1503A — ELECTRIC SUBMERSIBLE PUMP ASSY.

ST-1503A - ELECTRIC SUBMERSIBLE PUMP ASSY.

<u>NO</u>	<u>PART NO</u>	<u>PART NAME</u>	<u>QTY.</u>	<u>REMARK</u>
1	0201503A001	CASING	1	
3	0201503A003	IMPELLER	1	
4	0201503A004	IMPELLER NUT	1	
5	0201503A005	IMPELLER NUT WASHER	1	
6	0201503A006	IMPELLER KEY	1	
8	0201503A008	CASING PACKING	1	
47	0201503A047A	LINER (0.2MM)	1	
47	0201503A047B	LINER (0.3MM)	1	
60	0201503A060	MECHANICAL SEAL	1	
65	0201503A065	PLUG	1	
81	0201503A081	OIL SEAL	1	
102	0201503A102	DISCHARGE PORT	1	
103	0201503A103	PACKING	1	
104	0201503A104	BOLT	2	
112	0201503A112	OIL SEAL FOR OIL CHAMBER	1	
119	0201503A119	MOTOR	1	
120	0201503A120	AC CORD W/CORD GLAND	1	
121	0201503A121	CORD CLAMP	1	
122	0201503A122	HANGER METAL	1	
123	0201503A123	CHAIN	1	
125	0201503A125	SCREW	2	
127	0201503A127	CARRYING HANDLE	1	
129	0201503A129	FRAME COVER	1	
130	0201503A130	PACKING	1	
131	0201503A131	BOLT	4	
132	0201503A132	SPRING WASHER	4	
146	0210503A146	STRAINER	1	
147	0201503A147	BOLT	3	
160	0201503A160	SLEEVE	1	
174	0201503A174	OUTER PIPE	1	

ST-1503A — ELECTRIC SUBMERSIBLE PUMP ASSY.

ST-1503A - ELECTRIC SUBMERSIBLE PUMP ASSY.

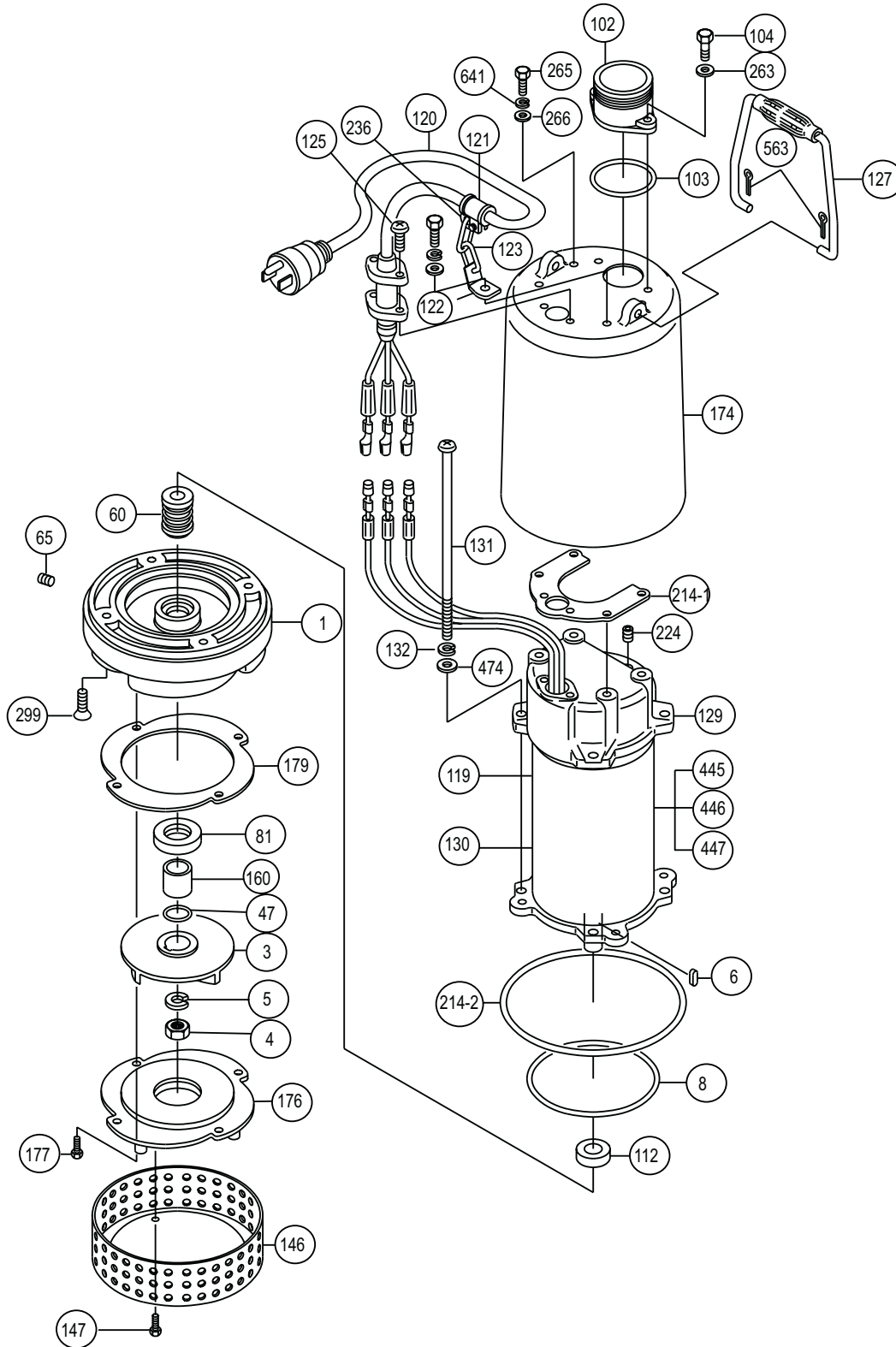

ST-1503A — ELECTRIC SUBMERSIBLE PUMP ASSY.

ST-1503A - ELECTRIC SUBMERSIBLE PUMP ASSY.

176	0201503A176	SUC COVER	1
177	0201503A177	BOLT	4
179	0201503A179	PACKING	1
214-1	0201503A214A	PACKING	1
214-2	0201503A214B	PACKING	1
224	0201503A224	PLUG	1
236	0201503A236	S-TIP	1
263	0201503A263	WASHER	2
265	0201503A265	BOLT	4
266	0201503A266	WASHER	4
299	0201503A299	SCREW 6MM X 40MM	4
445	0201503A445	CONDENSER STARTING	1
446	0201503A446	AUTO-CUT	1
447	0201503A447	CENTRIFUGAL SWITCH	1
474	0201503A474	WASHER	4
563	0201503A563	SPLIT PIN	2

ST-1503CUL — ELECTRIC SUBMERSIBLE PUMP ASSY.

ST-1503CUL SUBMERSIBLE PUMP ASSY.

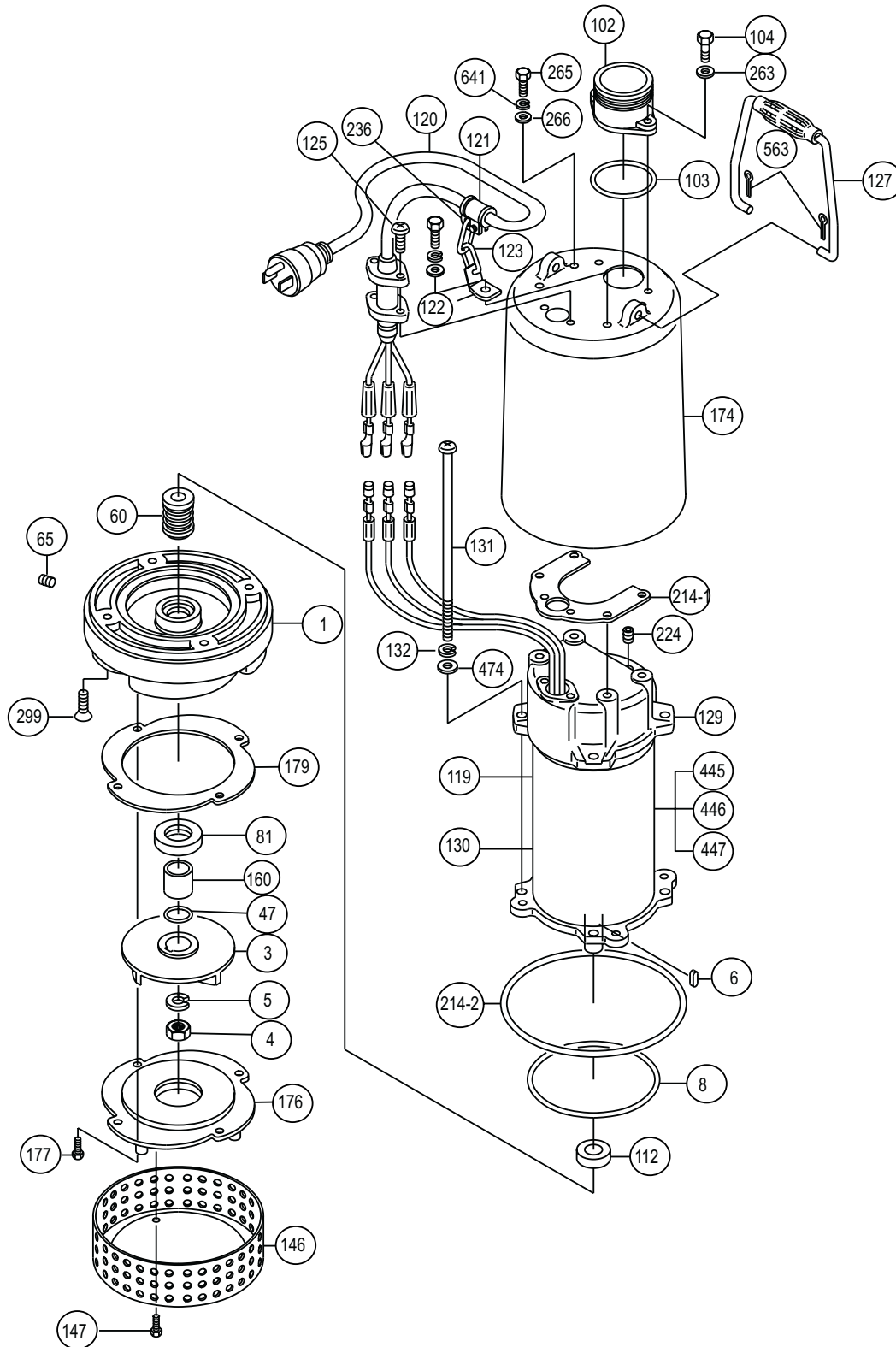

ST-1503CUL — ELECTRIC SUBMERSIBLE PUMP ASSY.

ST-1503CUL SUBMERSIBLE PUMP ASSY.

<u>NO</u>	<u>PART NO</u>	<u>PART NAME</u>	<u>QTY.</u>	<u>REMARK</u>
1	0201503001	CASING	1	
3	0201503003	IMPELLER	1	
4	0201503004	IMPELLER NUT	1	
5	0201503005	IMPELLER NUT WASHER	1	
6	0201503006	IMPELLER KEY	1	
8	0201503UL008	CASING PACKING	1	
47	0201503047A	LINER (0.2MM)	1	
47	0201503047B	LINER (0.3MM)	1	
60	0201503060	MECHANICAL SEAL	1	
65	0201503065	PLUG	1	
81	0201503081	OIL SEAL	1	
102	0201503A102	DISCHARGE PORT	1	
103	0201503A103	PACKING	1	
104	0201503A104	BOLT	2	
112	0201503A112	OIL SEAL FOR OIL CHAMBER	1	
119	0201503UL119	MOTOR	1	
120	0201503UL120	AC CORD W/CORD GLAND	1	
121	0201503121	CORD CLAMP	1	
122	0201503122	HANGER METAL	1	
123	0201503123	CHAIN	1	
125	0201503125	SCREW	2	
127	0201503127	CARRYING HANDLE	1	
129	0201503129	FRAME COVER	1	
130	0201503UL130	PACKING	1	
131	0201503131	BOLT	4	
132	0201503132	SPRING WASHER	4	
146	0201503146	STRAINER	1	
147	0201503147	BOLT	3	
160	0201503160	SLEEVE	1	
174	0201503UL174	OUTER PIPE	1	

ST-1503CUL — ELECTRIC SUBMERSIBLE PUMP ASSY.

ST-1503CUL - ELECTRIC SUBMERSIBLE PUMP ASSY.

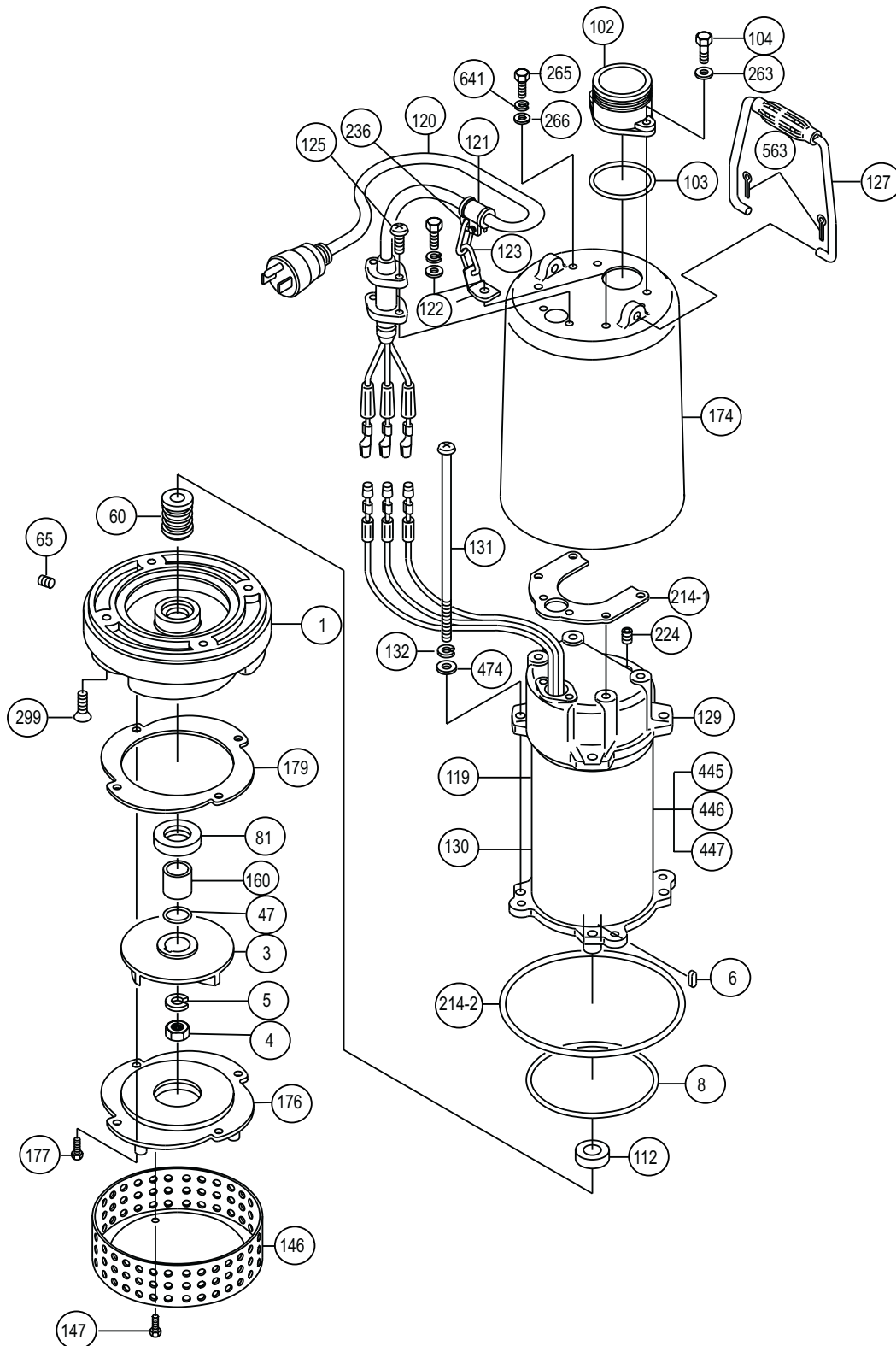

ST-1503CUL — ELECTRIC SUBMERSIBLE PUMP ASSY.

ST-1503CUL - ELECTRIC SUBMERSIBLE PUMP ASSY.

176	0201503176	SUC COVER	1
177	0201503177	BOLT	4
179	0201503179	PACKING	1
214-1	0201503UL214	PACKING	1
214-2	0201503214B	PACKING	1
224	0201503224	PLUG	1
236	0201503236	S-TIP	1
263	0201503263	WASHER	2
265	0201503265	BOLT	4
266	0201503266	WASHER	4
299	0201503299	SCREW 5 X 30	4
299	0201503299	SCREW 6MM X 40MM	4
446	0201503UL446	AUTO-CUT	1
447	0201503A447	CENTRIFUGAL SWITCH	1
474	0201503A474	WASHER	4
563	0201503A563	SPLIT PIN	2
641	0201503641	SPRING WASHER	4

ST-1503A/CUL — ELECTRIC MOTOR ASSY.

ST-1503A/CUL ELECTRIC MOTOR ASSY.

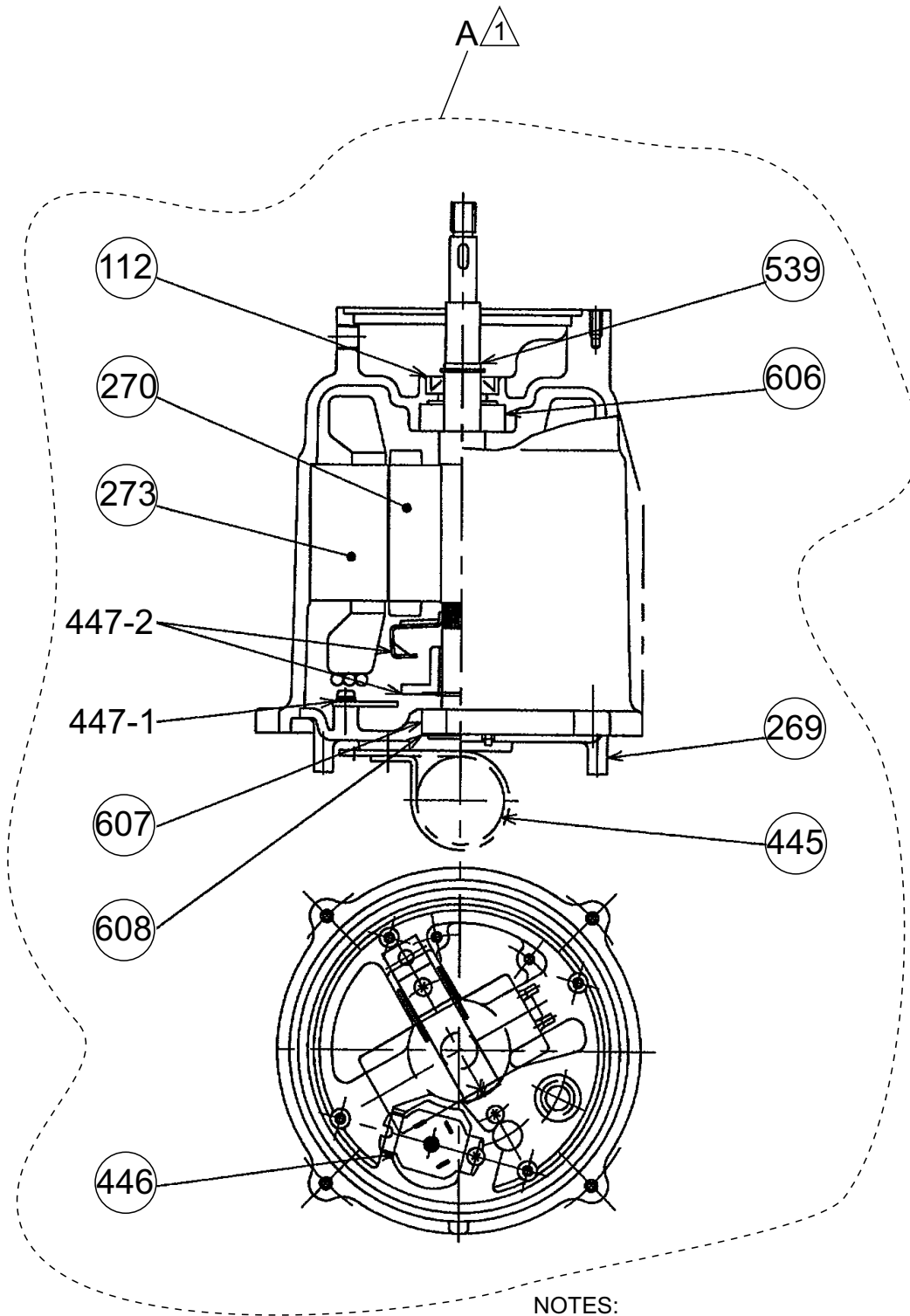

NOTES:

 COMPLETE ASSEMBLY INCLUDES
ITEMS WITHIN DASHED LINES

ST-1503A/CUL — ELECTRIC MOTOR ASSY.

ST-1503A/CUL ELECTRIC MOTOR ASSY.

<u>NO</u>	<u>PART NO</u>	<u>PART NAME</u>	<u>QTY.</u>	<u>REMARK</u>
112*	0201503112	OIL SEAL	1	
129*	0201503A129	MOTOR HEAD COVER	1	
131*	0201503A131	BOLT	4	
132*	0201503A132	SPRING WASHER	4	
268*	0201503A268	MOTOR A BRACKET	1	
270*	0201503UL270	MOTOR ROTOR	1	
273*	0201503UL273	MOTOR STATOR	1	
446*	0201503UL446	AUTO-CUT (PROTECTOR)	1	
447-1*	0202005T4471	CENTRIFUGAL SWITCH-1	1	
447-2*	0201503A4472	CENTRIFUGAL SWITCH-2	1	
539*	0202005T539	SNAP RING	1	
540*	0201503UL540	A PACKING	1	
541*	0201503UL541	B PACKING	1	
606*	0202005T606	MOTOR A BEARING	1	
607*	0202005S607	MOTOR B BEARING	1	
608*	0202005T608	WAVE WASHER	1	
611	0201503A611	MOTOR GUARD	1	
A	0201503UL119	MOTOR ASSEMBLY	1	INCLUDES ITEMS W/*

PAYMENT TERMS

Terms of payment for parts are net 10 days.

FREIGHT POLICY

All parts orders will be shipped collect or prepaid with the charges added to the invoice. All shipments are F.O.B. point of origin. Multiquip's responsibility ceases when a signed manifest has been obtained from the carrier, and any claim for shortage or damage must be settled between the consignee and the carrier.

MINIMUM ORDER

The minimum charge for orders from Multiquip is \$15.00 net. Customers will be asked for instructions regarding handling of orders not meeting this requirement.

RETURNED GOODS POLICY

Return shipments will be accepted and credit will be allowed, subject to the following provisions:

1. A Returned Material Authorization must be approved by Multiquip prior to shipment.
2. To obtain a Return Material Authorization, a list must be provided to Multiquip Parts Sales that defines item numbers, quantities, and descriptions of the items to be returned.
 - a. The parts numbers and descriptions must match the current parts price list.
 - b. The list must be typed or computer generated.
 - c. The list must state the reason(s) for the return.
 - d. The list must reference the sales order(s) or invoice(s) under which the items were originally purchased.
 - e. The list must include the name and phone number of the person requesting the RMA.
3. A copy of the Return Material Authorization must accompany the return shipment.
4. Freight is at the sender's expense. All parts must be returned freight prepaid to Multiquip's designated receiving point.

5. Parts must be in new and resalable condition, in the original Multiquip package (if any), and with Multiquip part numbers clearly marked.
6. The following items are not returnable:
 - a. Obsolete parts. (If an item is in the price book and shows as being replaced by another item, it is obsolete.)
 - b. Any parts with a limited shelf life (such as gaskets, seals, "O" rings, and other rubber parts) that were purchased more than six months prior to the return date.
 - c. Any line item with an extended dealer net price of less than \$5.00.
 - d. Special order items.
 - e. Electrical components.
 - f. Paint, chemicals, and lubricants.
 - g. Decals and paper products.
 - h. Items purchased in kits.
7. The sender will be notified of any material received that is not acceptable.
8. Such material will be held for five working days from notification, pending instructions. If a reply is not received within five days, the material will be returned to the sender at his expense.
9. Credit on returned parts will be issued at dealer net price at time of the original purchase, less a 15% restocking charge.
10. In cases where an item is accepted, for which the original purchase document can not be determined, the price will be based on the list price that was effective twelve months prior to the RMA date.
11. Credit issued will be applied to future purchases only.

PRICING AND REBATES

Prices are subject to change without prior notice. Price changes are effective on a specific date and all orders received on or after that date will be billed at the revised price. Rebates for price declines and added charges for price increases will not be made for stock on hand at the time of any price change.

Multiquip reserves the right to quote and sell direct to Government agencies, and to Original Equipment Manufacturer accounts who use our products as integral parts of their own products.

SPECIAL EXPEDITING SERVICE

A \$35.00 surcharge will be added to the invoice for special handling including bus shipments, insured parcel post or in cases where Multiquip must personally deliver the parts to the carrier.

LIMITATIONS OF SELLER'S LIABILITY

Multiquip shall not be liable hereunder for damages in excess of the purchase price of the item with respect to which damages are claimed, and in no event shall Multiquip be liable for loss of profit or good will or for any other special, consequential or incidental damages.

LIMITATION OF WARRANTIES

No warranties, express or implied, are made in connection with the sale of parts or trade accessories nor as to any engine not manufactured by Multiquip. Such warranties made in connection with the sale of new, complete units are made exclusively by a statement of warranty packaged with such units, and Multiquip neither assumes nor authorizes any person to assume for it any other obligation or liability whatever in connection with the sale of its products. Apart from such written statement of warranty, there are no warranties, express, implied or statutory, which extend beyond the description of the products on the face hereof.

OPERATION AND PARTS MANUAL

HERE'S HOW TO GET HELP

PLEASE HAVE THE MODEL AND SERIAL
NUMBER *ON-HAND* WHEN CALLING

MULTIQUIP CORPORATE OFFICE

18910 Wilmington Ave.
Carson, CA 90746
Email: mq@multiquip.com
Internet: www.multiquip.com

800-421-1244
FAX: 310-537-3927

PARTS DEPARTMENT

800-427-1244
310-537-3700

FAX: 800-672-7877
FAX: 310-637-3284

MAYCO PARTS

800-306-2926
310-537-3700

FAX: 800-672-7877
FAX: 310-637-3284

SERVICE DEPARTMENT

800-421-1244
310-537-3700

FAX: 310-537-4259

TECHNICAL ASSISTANCE

800-478-1244

FAX: 310-631-5032

WARRANTY DEPARTMENT

800-421-1244, EXT. 279
310-537-3700, EXT. 279

FAX: 310-537-1173

Your Local Dealer is:



MULTIQUIP INC.
18910 WILMINGTON AVE.
CARSON, CALIFORNIA 90746
800-421-1244 • 310-537-3700
FAX: 310-537-3927
E-mail: mq@multiquip.com
Internet: multiquip.com

Free Manuals Download Website

<http://myh66.com>

<http://usermanuals.us>

<http://www.somanuals.com>

<http://www.4manuals.cc>

<http://www.manual-lib.com>

<http://www.404manual.com>

<http://www.luxmanual.com>

<http://aubethermostatmanual.com>

Golf course search by state

<http://golfingnear.com>

Email search by domain

<http://emailbydomain.com>

Auto manuals search

<http://auto.somanuals.com>

TV manuals search

<http://tv.somanuals.com>