

OPERATION AND PARTS MANUAL





Mikasa SERIES
MODEL MVC80VH/VHW
ONE-WAY PLATE COMPACTOR
(HONDA GX160U1SM12 GASOLINE ENGINE)

Revision #3 (01/13/11)

To find the latest revision of this
publication, visit our website at:
www.multiquip.com



THIS MANUAL MUST ACCOMPANY THE EQUIPMENT AT ALL TIMES.

 **WARNING** 

CALIFORNIA — Proposition 65 Warning

Gasoline engine exhaust and some of its constituents are known to the State of California to cause cancer, birth defects and other reproductive harm.

TABLE OF CONTENTS

MVC80VH/VHW

Plate Compactor

Proposition 65 Warning	2
Table Of Contents	4
Parts Ordering Procedures	5
Safety Information	6-10
Specifications	11
Dimensions	12
General Information	13
Components	14
Basic Engine	15
Inspection	16-17
Startup	18-19
Operation	19
Maintenance	20-22
Preparation For Long Term Storage	23
Troubleshooting	24-25
Explanation Of Codes In Remarks Column	26
Suggested Spare Parts	27

Honda GX160U1SM12 Engine

Cylinder Head Assembly	38-39
Cylinder Barrel (Recoil) Assembly	40-41
Crankcase Cover Assembly	42-43
Crankshaft Assembly	44-45
Piston/Rings Assembly	46-47
Camshaft Assembly	48-49
Recoil Starter	50-51
Fan Cover Assembly	52-53
Carburetor Assembly	54-55
Air Cleaner Assembly	56-57
Muffler Assembly	58-59
Fuel Tank Assembly	60-61
Cooling Fan & Flywheel Assembly	62-63
Ignition Coil Assembly	64-65
Control Assembly	66-67
Terms and Conditions Of Sale — Parts	68

Component Drawings

Nameplate and Decals	28-29
Main Body Assembly	30-31
Vibrator Assembly	32-33
Water Tank Assembly (Option)	34-35
Transport Wheel Assembly (Option)	36-37

NOTICE

Specification and part number are subject to change without notice.

PARTS ORDERING PROCEDURE

Ordering parts has never been easier! Choose from three easy options:

Effective:
January 1st, 2006



Order via Internet (Dealers Only):

Order parts on-line using Multiquip's SmartEquip website!

- View Parts Diagrams
- Order Parts
- Print Specification Information



If you have an MQ Account, to obtain a Username and Password, E-mail us at: parts@multiquip.com.

To obtain an MQ Account, contact your District Sales Manager for more information.

Goto www.multiquip.com and click on

Order Parts to log in and save!

Use the **internet** and qualify for a **5% Discount** on **Standard orders** for all orders which include complete part numbers.*

Note: Discounts Are Subject To Change

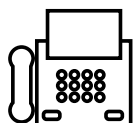

Order via Fax (Dealers Only):

All customers are welcome to order parts via Fax.

Domestic (US) Customers dial:
1-800-6-PARTS-7 (800-672-7877)

Fax your order in and qualify for a **2% Discount** on **Standard orders** for all orders which include complete part numbers.*

Note: Discounts Are Subject To Change



Order via Phone: Domestic (US) Dealers Call:
1-800-427-1244

Non-Dealer Customers:

Contact your local Multiquip Dealer for parts or call 800-427-1244 for help in locating a dealer near you.



International Customers should contact their local Multiquip Representatives for Parts Ordering information.

When ordering parts, please supply:

- | | |
|---|--|
| <input type="checkbox"/> Dealer Account Number | <input type="checkbox"/> Specify Preferred Method of Shipment: |
| <input type="checkbox"/> Dealer Name and Address | <input checked="" type="checkbox"/> UPS/Fed Ex <input checked="" type="checkbox"/> DHL |
| <input type="checkbox"/> Shipping Address (if different than billing address) | <input checked="" type="checkbox"/> Priority One <input checked="" type="checkbox"/> Truck |
| <input type="checkbox"/> Return Fax Number | <input checked="" type="checkbox"/> Ground |
| <input type="checkbox"/> Applicable Model Number | <input checked="" type="checkbox"/> Next Day |
| <input type="checkbox"/> Quantity, Part Number and Description of Each Part | <input checked="" type="checkbox"/> Second/Third Day |

NOTICE

All orders are treated as *Standard Orders* and will ship the same day if received prior to 3PM PST.

WE ACCEPT ALL MAJOR CREDIT CARDS!



www.multiquip.com



SAFETY INFORMATION

Do not operate or service the equipment before reading the entire manual. Safety precautions should be followed at all times when operating this equipment. Failure to read and understand the safety messages and operating instructions could result in injury to yourself and others.



SAFETY MESSAGES

The four safety messages shown below will inform you about potential hazards that could injure you or others. The safety messages specifically address the level of exposure to the operator and are preceded by one of four words: **DANGER**, **WARNING**, **CAUTION** or **NOTICE**.

SAFETY SYMBOLS

! DANGER

Indicates a hazardous situation which, if not avoided, **WILL** result in **DEATH** or **SERIOUS INJURY**.

! WARNING

Indicates a hazardous situation which, if not avoided, **COULD** result in **DEATH** or **SERIOUS INJURY**.

! CAUTION

Indicates a hazardous situation which, if not avoided, **COULD** result in **MINOR** or **MODERATE INJURY**.

NOTICE

Addresses practices not related to personal injury.

Potential hazards associated with the operation of this equipment will be referenced with hazard symbols which may appear throughout this manual in conjunction with safety messages.

Symbol	Safety Hazard
	Lethal exhaust gas hazards
	Explosive fuel hazards
	Burn hazards
	Respiratory hazards
	Accidental starting hazards
	Eye and hearing hazards
	Rotating parts hazards

SAFETY INFORMATION

GENERAL SAFETY

CAUTION

- **NEVER** operate this equipment without proper protective clothing, shatterproof glasses, respiratory protection, hearing protection, steel-toed boots and other protective devices required by the job or city and state regulations.



- **NEVER** operate this equipment when not feeling well due to fatigue, illness or when under medication.



- **NEVER** operate this equipment under the influence of drugs or alcohol.



- **ALWAYS** check the equipment for loosened threads or bolts before starting.
- **DO NOT** use the equipment for any purpose other than its intended purposes or applications.
- **ALWAYS** clear the work area of any debris, tools, etc. that would constitute a hazard while the equipment is in operation.

NOTICE

- This equipment should only be operated by trained and qualified personnel 18 years of age and older.
- Whenever necessary, replace nameplate, operation and safety decals when they become difficult read.
- Manufacturer does not assume responsibility for any accident due to equipment modifications. Unauthorized equipment modification will void all warranties.
- **NEVER** use accessories or attachments that are not recommended by Multiquip for this equipment. Damage to the equipment and/or injury to user may result.
- **ALWAYS** know the location of the nearest **fire extinguisher**.
- **ALWAYS** know the location of the nearest **first aid kit**.
- **ALWAYS** know the location of the nearest phone or **keep a phone on the job site**. Also, know the phone numbers of the nearest **ambulance, doctor and fire department**. This information will be invaluable in the case of an emergency.



SAFETY INFORMATION

COMPACTOR SAFETY

DANGER

- **NEVER** operate the equipment in an explosive atmosphere or near combustible materials. An explosion or fire could result causing severe **bodily harm or even death.**



WARNING

- **NEVER** disconnect any **emergency or safety devices.** These devices are intended for operator safety. Disconnection of these devices can cause severe injury, bodily harm or even death. Disconnection of any of these devices will void all warranties.

CAUTION

- **NEVER** lubricate components or attempt service on a running machine.

NOTICE

- **ALWAYS** keep the machine in proper running condition.
- Fix damage to machine and replace any broken parts immediately.
- **ALWAYS** store equipment properly when it is not being used. Equipment should be stored in a clean, dry location out of the reach of children and unauthorized personnel.

ENGINE SAFETY

DANGER

- The engine fuel exhaust gases contain poisonous carbon monoxide. This gas is colorless and odorless, and can cause death if inhaled.
- The engine of this equipment requires an adequate free flow of cooling air. **NEVER** operate this equipment in any enclosed or narrow area where free flow of the air is restricted. If the air flow is restricted it will cause injury to people and property and serious damage to the equipment or engine.



WARNING

- **DO NOT** place hands or fingers inside engine compartment when engine is running.
- **NEVER** operate the engine with heat shields or guards removed.
- Keep fingers, hands hair and clothing away from all moving parts to prevent injury.
- **DO NOT** remove the radiator cap while the engine is hot. High pressure boiling water will gush out of the radiator and severely scald any persons in the general area of the compactor.
- **DO NOT** remove the coolant drain plug while the engine is hot. Hot coolant will gush out of the coolant tank and severely scald any persons in the general area of the compactor.
- **DO NOT** remove the engine oil drain plug while the engine is hot. Hot oil will gush out of the oil tank and severely scald any persons in the general area of the compactor.



CAUTION

- **NEVER** touch the hot exhaust manifold, muffler or cylinder. Allow these parts to cool before servicing equipment.



NOTICE

- **NEVER** run engine without an air filter or with a dirty air filter. Severe engine damage may occur. Service air filter frequently to prevent engine malfunction.
- **NEVER** tamper with the factory settings of the engine or engine governor. Damage to the engine or equipment can result if operating in speed ranges above the maximum allowable.
- **NEVER** tip the engine to extreme angles during lifting as it may cause oil to gravitate into the cylinder head, making the engine start difficult.





SAFETY INFORMATION

FUEL SAFETY

DANGER

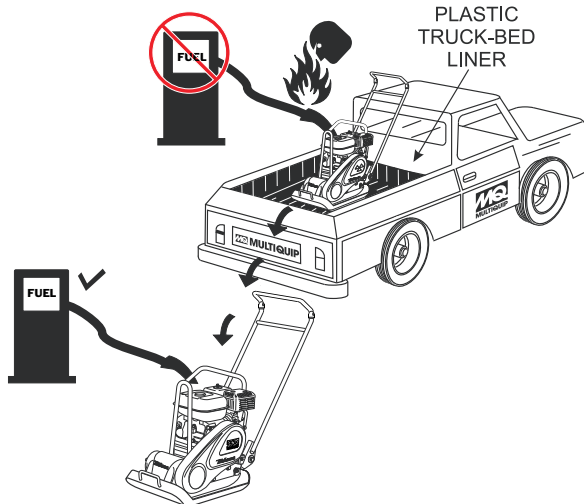
- **DO NOT** add fuel to equipment if it is placed inside truck bed with plastic liner. Possibility exists of explosion or fire due to static electricity.





- **DO NOT** start the engine near spilled fuel or combustible fluids. Diesel fuel is extremely flammable and its vapors can cause an explosion if ignited.
- **ALWAYS** refuel in a well-ventilated area, away from sparks and open flames.
- **ALWAYS** use extreme caution when working with **flammable** liquids.
- **DO NOT** fill the fuel tank while the engine is running or hot.
- **DO NOT** overfill tank, since spilled fuel could ignite if it comes into contact with hot engine parts or sparks from the ignition system.
- Store fuel in appropriate containers, in well-ventilated areas and away from sparks and flames.
- **NEVER** use fuel as a cleaning agent.
- **DO NOT** smoke around or near the equipment. Fire or explosion could result from fuel vapors or if fuel is spilled on a hot engine. 

BATTERY SAFETY (ELECTRIC START ONLY)

DANGER

- **DO NOT** drop the battery. There is a possibility that the battery will explode.
- **DO NOT** expose the battery to open flames, sparks, cigarettes, etc. The battery contains combustible gases and liquids. If these gases and liquids come into contact with a flame or spark, an explosion could occur. 

WARNING

- **ALWAYS** wear safety glasses when handling the battery to avoid eye irritation. The battery contains acids that can cause injury to the eyes and skin. 
- Use well-insulated gloves when picking up the battery.
- **ALWAYS** keep the battery charged. If the battery is not charged, combustible gas will build up.
- **DO NOT** charge battery if frozen. Battery can explode. When frozen, warm the battery to at least 61°F (16°C).
- **ALWAYS** recharge the battery in a well-ventilated environment to avoid the risk of a dangerous concentration of combustible gases.
- If the battery liquid (dilute sulfuric acid) comes into contact with **clothing or skin**, rinse skin or clothing immediately with plenty of water. 
- If the battery liquid (dilute sulfuric acid) comes into contact with **eyes**, rinse eyes immediately with plenty of water and contact the nearest doctor or hospital to seek medical attention.

CAUTION

- **ALWAYS** disconnect the **NEGATIVE** battery terminal before performing service on the equipment.
- **ALWAYS** keep battery cables in good working condition. Repair or replace all worn cables.

TRANSPORTING SAFETY

CAUTION

- NEVER allow any person or animal to stand underneath the equipment while lifting.

NOTICE

- Before lifting, make sure that the equipment parts (hook and vibration insulator) are not damaged and screws are not loose or missing.
- Always make sure crane or lifting device has been properly secured to the lifting bail (hook) of the equipment.
- **ALWAYS** shutdown engine before transporting.
- **NEVER** lift the equipment while the engine is running.
- Tighten fuel tank cap securely and close fuel cock to prevent fuel from spilling.
- Use adequate lifting cable (wire or rope) of sufficient strength.
- Use one point suspension hook and lift straight upwards.
- **DO NOT** lift machine to unnecessary heights.
- **ALWAYS** tie down equipment during transport by securing the equipment with rope.

ENVIRONMENTAL SAFETY

NOTICE

- Dispose of hazardous waste properly. Examples of potentially hazardous waste are used motor oil, fuel and fuel filters. 
- **DO NOT** use food or plastic containers to dispose of hazardous waste.
- **DO NOT** pour waste, oil or fuel directly onto the ground, down a drain or into any water source.

TABLE 1. Specifications (Compactor)

Models	MVC-80VH/MVC-80VHW
Centrifugal Force	2,928 lbs. (1,327 kg)
Number of Vibrations	5,600 vibrations/min (93Hz)
Traveling Speed	72 ft./min (22 meters/min)
Plate Size (LxW)	22.4 x 17.7 in. 570 x 450 mm
Overall Dimensions (L x W x H)	36.6 x 17.7 x 39.4 in. (930 x 450 x 1000 mm)
Operating Weight (VH) Operating Weight (VHW)	161 lbs. (80.5 kg.) 183 lbs. (88.5 kg.)
Water Tank Capacity (VHW Model Only)	13.8 qt. (13.0 liters)
Max. Area Of Compaction	6,827 sq. ft./hr. (660 sq. m/hr)

Table 2. Specifications (Engine)

Table 2. Specifications (Engine)		
Engine	Model	HONDA GX160U1SM12
	Type	Air-cooled 4 stroke, Single Cylinder, OHV, Horizontal Shaft Gasoline Engine
	Bore X Stroke	2.7 in. x 1.8 in. (68 mm x 45 mm)
	Displacement	163 cc (9.9 cu-in)
	Max Output	5.5 H.P./3600 R.P.M.
	Fuel Tank Capacity	Approx. 0.95 U.S. gallons (3.6 liters)
	Fuel	Unleaded Automobile Gasoline
	Lube Oil Capacity	.60 liters (0.63 qts)
	Speed Control Method	Centrifugal Fly-weight Type
	Starting Method	Recoil Start
Dimension (L x W x H)	120 x 14.2 x 13.2 in. (304 x 362 x 335 mm)	
Dry Net Weight	23.1 lbs (10.48 Kg.)	

DIMENSIONS

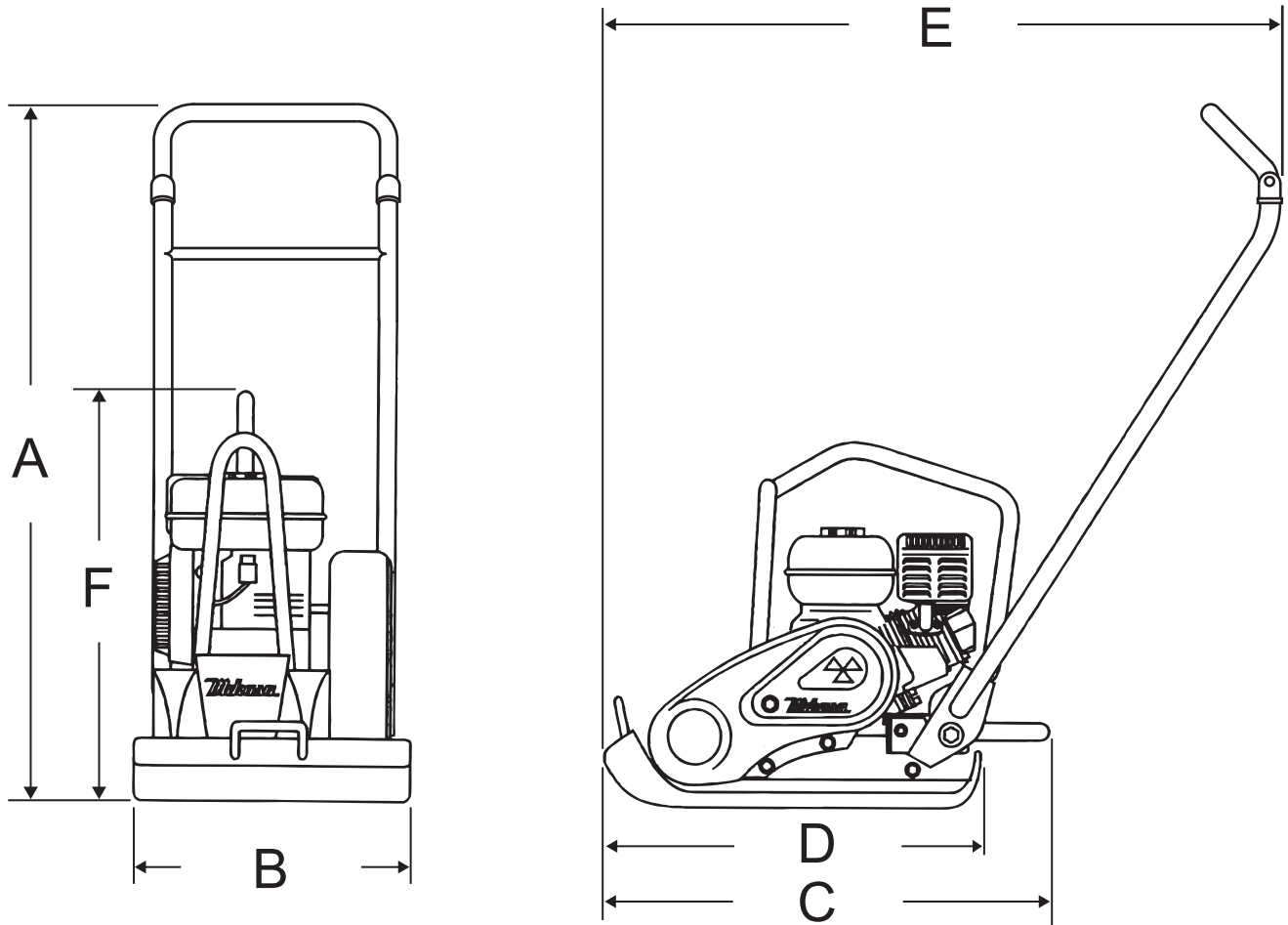

TABLE 3. DIMENSIONS

REFERENCE LETTER	DESCRIPTION	DIMENSION in. (mm)
A	Height (Handle Upright)	36 inches (1000 mm)
B	Width	17 inches (450 mm)
C	Length (Handle Upright)	24 inches (620 mm)
D	Plate Length	22 inches (570 mm)
E	Length (Handle Lowered)	37 inches (930 mm)
F	Height (Compactor Only)	23 inches (590 mm)
	Shipping Dimensions	35 x 19 x 26 inches (860 x 480 x 670 mm)

Definition of Plate Compactor

The Mikasa MVC80VH/VHW is a walk behind, plate compactor designed for the compaction of sand, mixed soils and asphalt. This plate compactor is a powerful compacting tool capable of applying a tremendous force in consecutive high frequency vibrations to a soil surface. Its applications include compacting for road, embankments and reservoirs as well as backfilling for gas pipelines, water pipelines and cable installation work.

Vibratory Plates

The vibratory plates of the MVC80VH/VHW produce low amplitude high frequency vibrations, designed to compact granular soils and asphalt.

The resulting vibrations cause forward motion. The engine and handle are vibration isolated from the vibrating plate.

Frequency/Speed

The compactor's vibrating plate has a frequency range between 5600 vpm (vibrations per minute). The travel speed of the compactor is approximately 72 ft./minute (22 meters/minute).

Engine

The Mikasa MVC80VH/VHW Plate Compactor is equipped with a Honda GX160U1SM12 gasoline engine.

Controls

Before starting the MVC80VH/VHW Plate Compactor identify and understand the function of the controls and components.

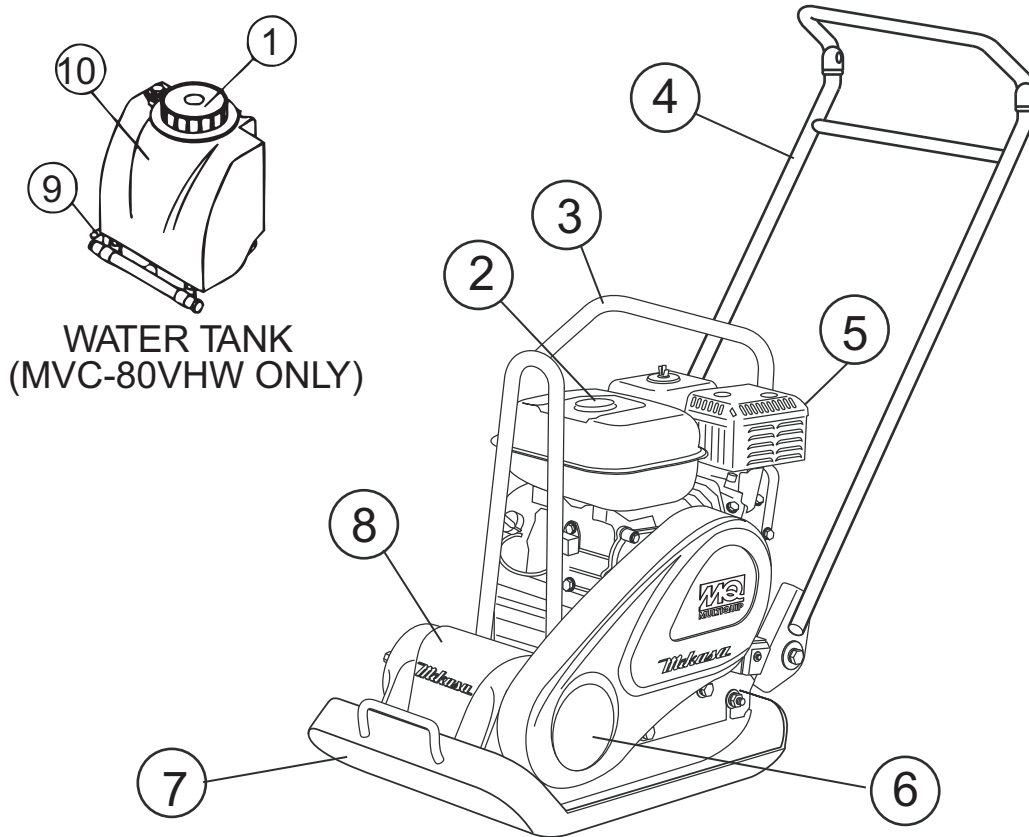

Figure 1. Plate Compactor Controls

Figure 1 shows the location of the basic controls and components of the MVC80VH/VHW Plate Compactor. The function of each control is described below:

1. **Water Tank Cap (VHW Only)** – Remove this cap to add water to the water tank.
2. **Fuel Tank Cap** – Remove this cap to add fuel.
3. **Lifting Bale** – When lifting of the compactor is required either by forklift, crane etc., tie rope or chain around this lifting point.
4. **Handle Bar** – When operating the compactor use this handle bar to maneuver the compactor.
5. **Gasoline Engine** – This plate compactor uses a HONDA GX160U1SM12 engine. Refer to the HONDA owner's manual for engine information and related topics.
6. **Belt Cover** – Remove this cover to gain access to the V-belts. **NEVER** run the compactor without the V-belt cover. If the V-belt cover is not installed, the possibility exists that your hand may get caught between the V-belt and clutch, causing serious injury and bodily harm.
7. **Vibrating Plate** – A flat, open plate made of durable cast iron construction used in the compacting of soil.
8. **Vibration Case** – Encloses the eccentric, gears and counter weights.
9. **Water Shut-Off Valve (VHW only)** – Turn this valve downward to let water flow from the water tank to the water tube.
10. **Water Tank (VHW only)** – Holds 13.8 quarts of water (removable, no tools required).

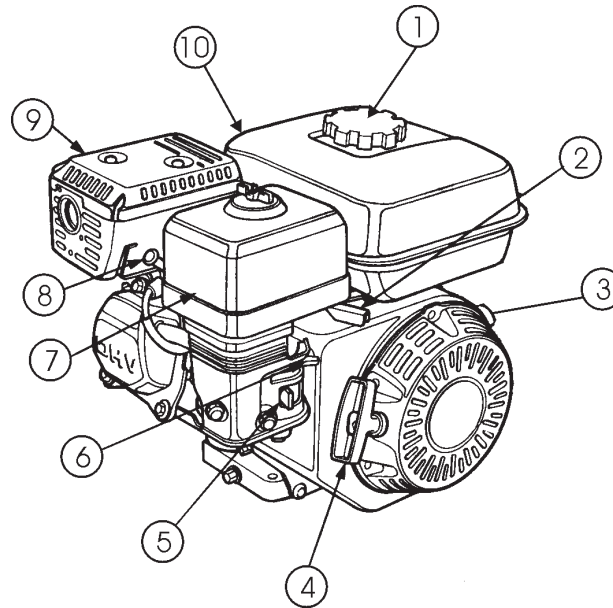



Figure 2. Engine Controls & Components

ENGINE COMPONENTS

The engine (Figure 2) must be checked for proper lubrication and filled with fuel prior to operation. Refer to the manufacturers Engine manual for instructions & details of operation and servicing.

1. **Fuel Filler Cap** – Remove this cap to add unleaded gasoline to the fuel tank. Make sure cap is tightened securely. **DO NOT** over fill.

⚠ WARNING



Add fuel to the tank only when the engine is stopped and has cooled down. In the event of a fuel spill, **DO NOT** attempt to start the engine until the fuel residue has been completely wiped up and the area surrounding the engine is dry.

2. **Throttle Lever** – Used to adjust engine RPM speed (lever advanced forward - **SLOW**, lever back toward operator - **FAST**).
3. **Engine ON/OFF Switch** – **ON** position permits engine starting, **OFF** position stops engine operations.
4. **Recoil Starter (pull rope)** – Manual-starting method. Pull the starter grip until resistance is felt, then pull briskly and smoothly.

5. **Fuel Valve Lever** – **OPEN** to let fuel flow, **CLOSE** to stop the flow of fuel.
6. **Choke Lever** – Used in the starting of a cold engine, or in cold weather conditions. The choke enriches the fuel mixture.
7. **Air Cleaner** – Prevents dirt and other debris from entering the fuel system. Remove wing-nut on top of air filter cannister to gain access to filter element.

NOTICE

Operating the engine without an air filter, with a damaged air filter, or a filter in need of replacement will allow dirt to enter the engine, causing rapid engine wear.

⚠ WARNING



Engine components can generate extreme heat. To prevent burns, **DO NOT** touch these areas while the engine is running or immediately after operating. **NEVER** operate the engine with the muffler removed.

8. **Spark Plug** – Provides spark to the ignition system. Set spark plug gap to 0.6 - 0.7 mm (0.028 - 0.031 inch) Clean spark plug once a week.
9. **Muffler** – Used to reduce noise and emissions.
10. **Fuel Tank** – Holds unleaded gasoline. For additional information refer to engine owner's manual.

Before Starting

1. Read safety instructions at the beginning of manual.
2. Clean the compactor, removing dirt and dust, particularly the engine cooling air inlet, carburetor and air cleaner.
3. Check the air filter for dirt and dust. If air filter is dirty, replace air filter with a new one as required.
4. Check carburetor for external dirt and dust. Clean with dry compressed air.
5. Check fastening nuts and bolts for tightness. Loosened screws or bolts due to vibration, could lead to unexpected accident.



NOTICE

The Oil Alert System will automatically stop the engine before the engine falls below safe limits. Always be sure to check the engine oil level prior to starting the engine.

Table 4. Oil Type

Season	Temperature	Oil Type
Summer	25°C or Higher	SAE 10W-30
Spring/Fall	25°C~10°C	SAE 10W-30/20
Winter	0°C or Lower	SAE 10W-10

Engine Oil Check

1. To check the engine oil level, place the pump on secure level ground with the engine stopped.
2. Remove the filler dipstick from the engine oil filler hole (Figure 3) and wipe clean.

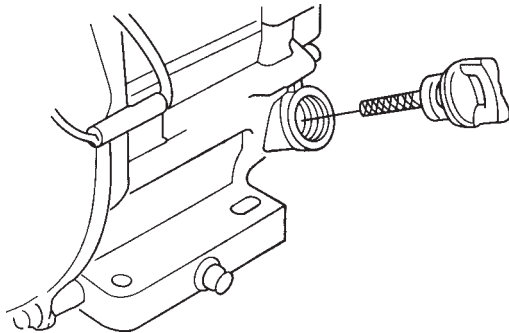

Figure 3. Engine Oil Dipstick (Removal)

3. Insert and remove the dipstick without screwing it into the filler neck. Check the oil level shown on the dipstick.
4. If the oil level is low (Figure 4), fill to the edge of the oil filler hole with the recommended oil type (Table 4). Maximum oil capacity is 0.63 quarts (0.60 liters)

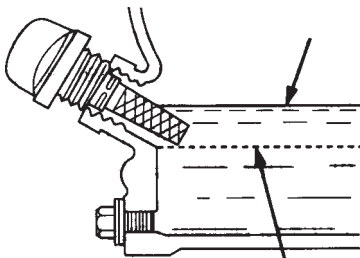
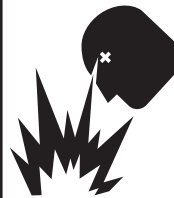

Figure 4. Engine Oil Dipstick (Oil Level)

DANGER



EXPLOSIVE FUEL!

Motor fuels are highly flammable and can be dangerous if mishandled. **DO NOT** smoke while refueling. **DO NOT** attempt to refuel if the engine is *hot* or *running*.

Fuel Check

1. Remove the gasoline cap located on top of fuel tank.
2. Visually inspect to see if the fuel level is low. If fuel is low, replenish with unleaded fuel.
3. When refueling, be sure to use a strainer for filtration. **DO NOT** top-off fuel. Wipe up any spilled fuel *immediately!*

CAUTION

NEVER attempt to check the V-belt with the engine running. Severe injury can occur if your hand (Figure 5) gets caught between the V-belt and the clutch. Always use safety gloves.

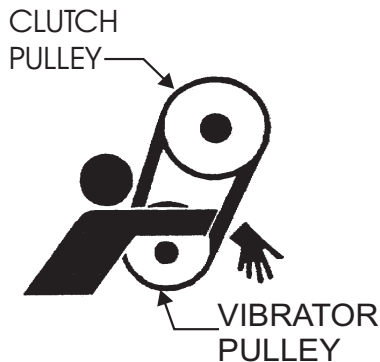

Figure 5. V-Belt Hazard

1. To check the V-belt tension, remove the three bolts that secure the belt cover to the frame as shown in Figure 6.

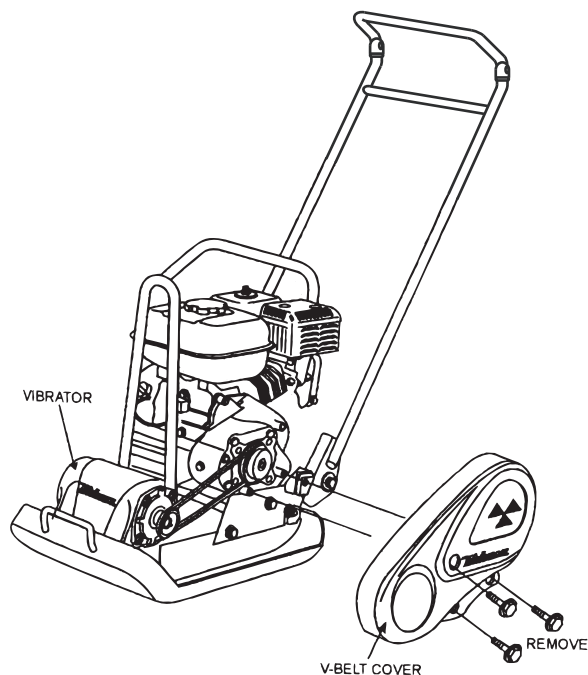

Figure 6. V-Belt Cover Removal

2. The V-belt tension is proper if the V-belt bends 10 to 15 mm (Figure 7) when depressed with finger at midway between the clutch and vibration pulley shafts.

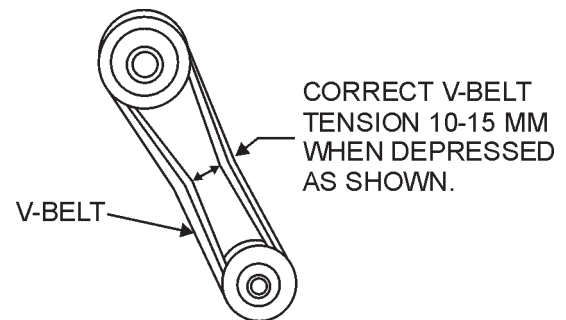

Figure 7. V-Belt Tension

3. A loose V-belt will decrease the power transmission output, causing reduced compaction and premature wear of the belt.
4. If the V-belt becomes worn or loose, replace it.

Vibrator Oil Check

1. Place the MVC80VH/VHW plate compactor horizontally on a flat surface. Make sure the compactor is level when checking the oil in the vibrator assembly.
2. Check vibrator oil level by removing the plug (vibrator oil gauge) as shown in Figure 8. The oil level should be up to the oil plug. The vibrator holds 140 cc (approximately 4 oz.). **IMPORTANT**, if oil is required, replace using only SAE 10W-30 motor oil.

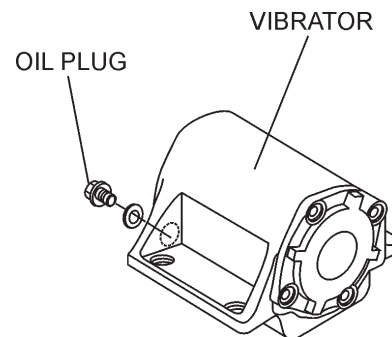

Figure 8. Vibrator Oil Plug

CAUTION



DO NOT attempt to run the compactor until the Safety and Initial Start-up sections have been read and understood.

NOTICE

The **CLOSED** position of the choke lever enriches the fuel mixture for starting a **COLD** engine. The **OPEN** position provides the correct fuel mixture for normal operation after starting, and for restarting a warm engine.

1. Place the **fuel valve lever** (Figure 9) in the "ON" position.

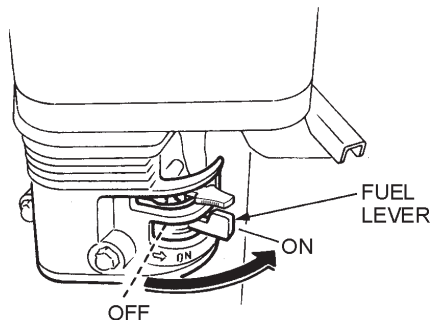

Figure 9. Fuel Valve Lever

2. Place the **Engine ON/OFF switch** (Figure 10) in the "ON" position.

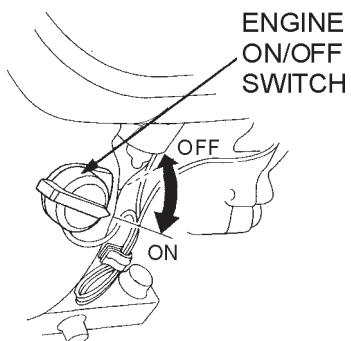

Figure 10. Engine ON/Off Switch

3. Place the **Choke Lever** (Figure 11) in the "OPEN" position.

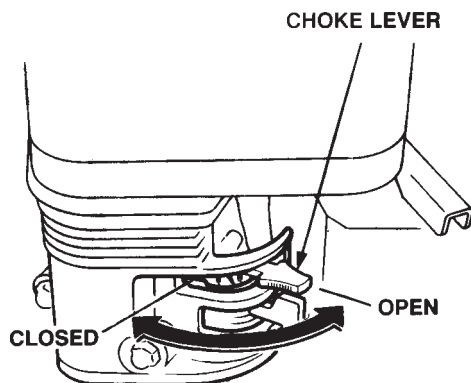

Figure 11. Choke Lever

4. Place the **throttle lever** (Figure 12) halfway between **fast** and **slow**.

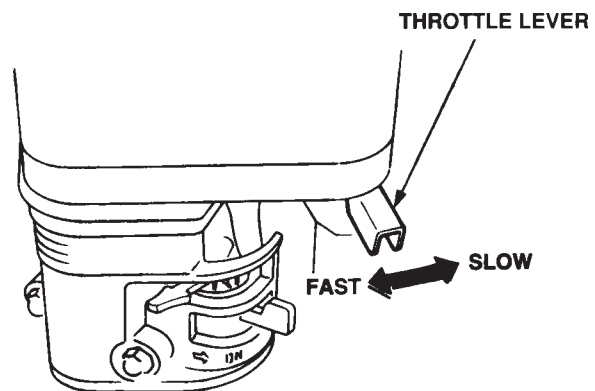

Figure 12. Throttle Lever

5. Grasp the starter grip (Figure 13) and slowly pull it out. The resistance becomes the hardest at a certain position, corresponding the compression point. Rewind the rope a little from that point and pull out sharply.

CAUTION

DO NOT pull the starter rope all the way to the end
DO NOT release the starter rope after pulling. Allow it to rewind as soon as possible.

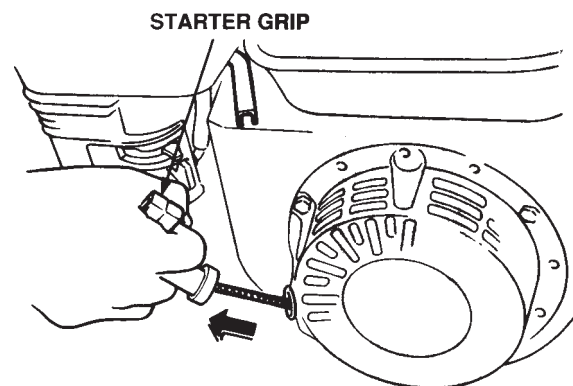

Figure 13. Starter Grip

6. If the engine has started, slowly return the choke lever (Figure 11) to the **CLOSED** position. If the engine has not started, repeat steps 1 through 5.
7. Before the compactor is put into operation, run the engine for 3-5 minutes.
8. Check for abnormal engine noises or fuel leaks.

Operation

CAUTION

Make sure to follow all safety rules referenced in the safety section of this manual before operating compactor. Keep work area clear of debris and other objects that could cause damage to the compactor or bodily injury.

1. Once the engine has started, move the engine throttle lever quickly to the **fast** position.
2. With the throttle lever in the fast position, the engine speed should be around 2,300 RPM, therefore engaging the centrifugal clutch.

NOTICE

ALWAYS move the throttle lever quickly without hesitation, because increasing the engine speed slowly causes the clutch to slip.

5. Firmly grasp the compactor's handle bar with both hands, the compactor will begin moving forward.
6. Slowly walk behind the compactor and be on the lookout for any large objects or foreign matter that might cause damage to the compactor or bodily injury.
7. Compactor traveling speed may drop on soils which contain clay, however there may be cases where traveling speed drops because the compaction plate does not leave the ground surface easily due to the composition of the soil. To rectify this problem do the following:
 - Check the bottom plate to see if clay or equivalent material has been lodged in the plate mechanism. If so, wash with water and remove.
 - Remember the compactor does not work as efficiently on clay or soils that have a high moisture content level.
 - If the soil has a high moisture level, dry soil to appropriate moisture content level or carry out compaction twice.

Stopping the Engine

NOTICE

NEVER stop the engine suddenly while working at high speeds.

Normal Shutdown

1. Place the **throttle lever** (Figure 12) in **slow** position, and listen for the engine speed to decrease.
2. Place the **Engine ON/OFF switch** (Figure 10) in the "**OFF**" position.
3. Place the **fuel valve lever** (Figure 9) in the "**OFF**" position.

Emergency Shutdown

1. Move the **throttle lever** quickly to the **slow** position, and place the **Engine ON/OFF switch** in the "**OFF**" position.

MAINTENANCE

⚠ CAUTION

Inspection and other services should **always** be carried out on hard and level ground with the engine shutdown.

⚠ CAUTION

These inspection intervals are for operation under normal conditions. Adjust your inspection intervals based on the number hours plate compactor is in use, and particular working conditions.

Inspection and Maintenance Service Tables.

- To make sure your plate compactor is always in good working condition before using, carry out the maintenance inspection in accordance with Tables 5 through 7.

⚠ CAUTION

Fuel piping and connections should be replaced every 2 years.

Table 5. Engine Maintenance Schedule

DESCRIPTION (3)	OPERATION	BEFORE	FIRST MONTH OR 10 HRS.	EVERY 3 MONTHS OR 25 HRS.	EVERY 6 MONTHS OR 50 HRS.	EVERY YEAR OR 100 HRS.	EVERY 2 YEARS OR 200 HRS.
Engine Oil	CHECK	X					
	CHANGE		X				
Air Cleaner	CHECK	X					
	CHANGE			X (1)			
All Nuts & Bolts	Re-tighten If Necessary	X					
Spark Plug	CHECK-CLEAN				X		
	REPLACE						X
Cooling Fins	CHECK				X		
Spark Arrester	CLEAN					X	
Fuel Tank	CLEAN					X	
Fuel Filter	CHECK					X	
Idle Speed	CHECK-ADJUST					X (2)	
Valve Clearance	CHECK-ADJUST						X (2)
Fuel lines	CHECK	Every 2 years (replace if necessary) (2)					

(1) Service more frequently when used in **DUSTY** areas.

(2) These items should be serviced by your service dealer, unless you have the proper tools and are mechanically proficient. Refer to the HONDA Shop Manual for service procedures.

(3) For commercial use, log hours of operation to determine proper maintenance intervals.

MAINTENANCE

TABLE 6. MACHINE INSPECTION

Item	Hours of Operation
(Starting check)	Every 8 hours (every day)
Loose or lost screws	Every 8 hours (every day)
Damage of any part	Every 8 hours (every day)
Function of controlling system part	Every 8 hours (every day)
Vibrator oil check	Every 100 hours
Vibrator oil replacement	Every 300 hours
V-belt (clutch) check	Every 200 hour

Daily Service

- Check for leakage of fuel or oil.
- Check engine oil.
- Check for loose screws including tightness. See Table 6 below (tightening torque), for retightening.

TABLE 7.

TIGHTENING TORQUE (in. kg/cm) Diameter

Material	6mm	8mm	10mm	12mm	14mm	16mm	18mm	20mm
4T	70	150	300	500	750	1,100	1,400	2,000
6-8T	100	250	500	800	1,300	2,000	2,700	3,800
11T	150	400	800	1,200	2,000	2,900	4,200	5,600
*	100 (6mm) 300 ~ 350 (8mm) 650 ~ 700 (10mm)							
* (In case counter-part is of aluminum)								
(Threads in use with this machine are all right handed)								
Material and quality of material is marked on each bolt, and screw.								

ENGINE OIL

1. Replace the engine oil in first 20 hours of operation and every 100 hours afterwards.
2. Drain the engine oil when the oil is **warm** after operation. Remove the oil filler cap then unscrew the engine oil drain plug located at the base of the engine. Drain the old oil into a pan (Figure 14).

3. Replace engine oil with recommended type oil as listed in Table 4. For engine oil capacity, see Table 2 (engine specifications). **DO NOT** overfill.
4. Reinstall drain bolt with sealing washer and tighten securely.

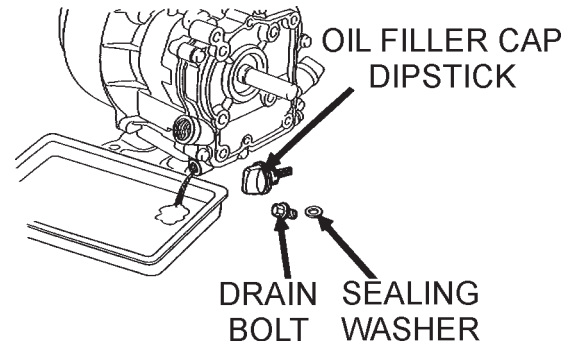

Figure 14. Engine Oil (Draining)

Air Filter

1. The air filter element should be cleaned because a clogged air cleaner can cause poor engine starting, lack of power and shorten engine life substantially.
2. To clean or replace air filter loosen the wing nut on the air filter housing (Figure 15), remove the cover and take out air filter cartridge. If only cleaning of the air filter is desired blow through the air filter cartridge from the inside, moving a jet of dry compressed air up and down until all dust is removed.

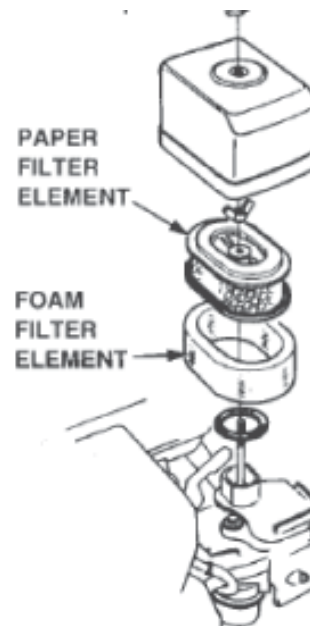

Figure 15. Air Cleaner

Spark Plug

1. Remove and clean the spark plug (Figure 16).
2. Adjust the spark gap to 0.028 ~0.031 inch (0.6~0.7 mm). This unit has electronic ignition, which requires no adjustments.

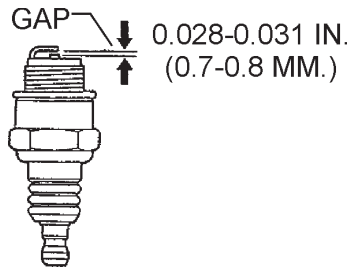

Figure 16. Spark Plug Gap

Changing Vibrator Oil

1. When changing the vibrator oil, remove the drain plug (Figure 8), and simply tip the compactor to drain the oil. Note that the oil will drain more easily while it is hot. Remember to use only 10W-30 motor oil when replacing vibrator oil.

Checking and Replacing the V-Belt and Clutch

1. After 200 hours of operation, remove the upper belt cover to check the V-belt tension. Tension is proper if the belt bends about 10 mm when depressed strongly with finger between shafts. Loose or worn V-belts reduces power transmission efficiency, causing weak compaction and reduces the life of the belt itself.

- Replacing the V-belt

Remove the upper and lower belt covers. Engage an offset wrench (13 mm) or the like to vibrator pulley (lower) fastening bolt. Engage waste cloth or the like at midway of V-belt on the left side and while pulling it back strongly, rotate the offset wrench clockwise so that the V-belt will come off.

- Reinstalling the V-belt

Engage V-belt to lower vibrator pulley and push the V-belt to left side of upper clutch and, in the same manner as in removal, rotate offset wrench clockwise so that the V-belt goes back on.

- Checking Clutch

Check the clutch simultaneously with V-belt checking. With belt removed, check outer drum of the clutch for seizure and "V" groove for wear or damage with your eyes. Clean the "V" groove as necessary. Wear of lining or shoe should be checked with running check. If the shoe is worn, power transmission becomes deficient and slipping will result.

WARNING

NEVER attempt to check the V-belt with the engine running. Severe injury can occur if your hand (Figure 5) gets caught between the V-belt and the clutch. Always use safety gloves.

WARNING

Whenever the compactor's vibration becomes weak or lost during normal operation regardless of operation hours, check the V-belt and clutch immediately.

PREPARATION FOR LONG-TERM STORAGE

Plate Compactor Storage

For storage of the plate compactor for over 30 days, the following is required:

- Drain the fuel tank completely or add STA-BIL to the fuel.
- Run the engine until the fuel is completely consumed.
- Completely drain the oil from the engine crankcase and follow procedures described in the **HONDA** engine Owner's Manual for engine storage.
- Completely drain the compactor's hydraulic oil from the vibrating case.
- Clean entire plate compactor, especially the bottom plate removing all dirt and foreign matter.
- Cover plate compactor and engine with plastic covering or equivalent and store in a clean, dry place.

TABLE 8. ENGINE TROUBLESHOOTING

SYMPTOM	POSSIBLE CAUSE	SOLUTION
Difficult to start, "fuel is available, but no SPARK at spark plug".	Spark plug bridging?	Check gap, insulation or replace spark plug.
	Carbon deposit on spark plug?	Clean or replace spark plug.
	Short circuit due to deficient spark plug insulation?	Check spark plug insulation, replace if worn.
	Improper spark plug gap?	Set to proper gap.
Difficult to start, "fuel is available, and SPARK is present at the spark plug".	ON/OFF switch is shorted?	Check switch wiring, replace switch.
	Ignition coil defective?	Replace ignition coil.
	Improper spark gap, points dirty?	Set correct spark gap and clean points.
	Condenser insulation worn or short circuiting?	Replace condenser.
	Spark plug wire broken or short circuiting?	Replace defective spark plug wiring.
Difficult to start, "fuel is available, spark is present and compression is normal"	Wrong fuel type?	Flush fuel system, and replace with correct type of fuel.
	Water or dust in fuel system?	Flush fuel system.
	Air cleaner dirty?	Clean or replace air cleaner.
Difficult to start, "fuel is available, spark is present and compression is low"	Suction/exhaust valve stuck or protruded?	Re-seat valves.
	Piston ring and/or cylinder worn?	Replace piston rings and or piston.
	Cylinder head and/or spark plug not tightened properly?	Torque cylinder head bolts and spark plug.
	Head gasket and/or spark plug gasket damaged?	Replace head and spark plug gaskets.
No fuel present at carburetor.	Fuel not available in fuel tank?	Fill with correct type of fuel.
	Fuel cock does not open properly?	Apply lubricant to loosen fuel cock lever, replace if necessary.
	Fuel filter clogged?	Replace fuel filter.
	Fuel tank cap breather hole clogged?	Clean or replace fuel tank cap.
	Air in fuel line?	Bleed fuel line.

TABLE 8. ENGINE TROUBLESHOOTING (CONTINUED)

SYMPTOM	POSSIBLE CAUSE	SOLUTION
"Weak in power" compression is proper and does not misfire.	Air cleaner not clean?	Clean or replace air cleaner
	Improper level in carburetor?	Check float adjustment, re-build carburetor.
	Defective Spark plug?	Clean or replace spark plug.
	Defective Spark plug?	
"Weak in power" compression is proper but misfires.	Water in fuel system?	Flush fuel system, and replace with correct type of fuel.
	Dirty spark plug?	Clean or replace spark plug.
	Ignition coil defective?	Replace ignition coil.
Engine overheats.	Spark plug heat value improper?	Replace with correct type of spark plug.
	Correct type of fuel?	Replace with correct type of fuel
	Cooling fins dirty?	Clean cooling fins.
Rotational speed fluctuates.	Governor adjusted correctly?	Adjust governor.
	Governor spring defective?	Replace governor spring.
	Fuel flow restricted?	Check entire fuel system for leaks or clogs.
Recoil starter malfunction.	Recoil mechanism clogged with dust and dirt?	Clean recoil assembly with soap and water.
	Spiral spring loose?	Replace spiral spring.

TABLE 9. PLATE COMPACTOR TROUBLESHOOTING

SYMPTOM	POSSIBLE CAUSE	SOLUTION
Travel speed too low, and vibration is weak.	Engine speed too low?	Set engine speed to correct RPM.
	Clutch slips?	Check or replace clutch.
	V-belt slips?	Adjust or replace V-belt.
	Excessive oil in vibrator?	Drain excess oil and fill to proper level.
	Malfunction in vibrator housing?	Check eccentric, gears and counter weights.
	Bearing Failure?	Replace Bearing
	Insufficient engine output?	Check engine, compression etc.

EXPLANATION OF CODES IN REMARKS COLUMN

The following section explains the different symbols and remarks used in the Parts section of this manual. Use the help numbers found on the back page of the manual if there are any questions.

NOTICE

The contents and part numbers listed in the parts section are subject to change **without notice**. Multiquip does not guarantee the availability of the parts listed.

SAMPLE PARTS LIST

NO.	PART NO.	PART NAME	QTY.	REMARKS
1	12345	BOLT.....	1	INCLUDES ITEMS W/%
2%		WASHER, 1/4 IN.....		NOT SOLD SEPARATELY
2%	12347	WASHER, 3/8 IN....	1	MQ-45T ONLY
3	12348	HOSE	A/R	MAKE LOCALLY
4	12349	BEARING	1	S/N 2345B AND ABOVE

NO. Column

Unique Symbols — All items with same unique symbol

(@, #, +, %, or >) in the number column belong to the same assembly or kit, which is indicated by a note in the “Remarks” column.

Duplicate Item Numbers — Duplicate numbers indicate multiple part numbers, which are in effect for the same general item, such as different size saw blade guards in use or a part that has been updated on newer versions of the same machine.

NOTICE

When ordering a part that has more than one item number listed, check the remarks column for help in determining the proper part to order.

PART NO. Column

Numbers Used — Part numbers can be indicated by a number, a blank entry, or TBD.

TBD (To Be Determined) is generally used to show a part that has not been assigned a formal part number at the time of publication.

A blank entry generally indicates that the item is not sold separately or is not sold by Multiquip. Other entries will be clarified in the “Remarks” Column.

QTY. Column

Numbers Used — Item quantity can be indicated by a number, a blank entry, or A/R.

A/R (As Required) is generally used for hoses or other parts that are sold in bulk and cut to length.

A blank entry generally indicates that the item is not sold separately. Other entries will be clarified in the “Remarks” Column.

REMARKS Column

Some of the most common notes found in the “Remarks” Column are listed below. Other additional notes needed to describe the item can also be shown.

Assembly/Kit — All items on the parts list with the same unique symbol will be included when this item is purchased.

Indicated by:

“INCLUDES ITEMS W/(unique symbol)”

Serial Number Break — Used to list an effective serial number range where a particular part is used.

Indicated by:

“S/N XXXXX AND BELOW”

“S/N XXXX AND ABOVE”

“S/N XXXX TO S/N XXX”

Specific Model Number Use — Indicates that the part is used only with the specific model number or model number variant listed. It can also be used to show a part is NOT used on a specific model or model number variant.

Indicated by:

“XXXXX ONLY”

“NOT USED ON XXXX”

“Make/Obtain Locally” — Indicates that the part can be purchased at any hardware shop or made out of available items. Examples include battery cables, shims, and certain washers and nuts.

“Not Sold Separately” — Indicates that an item cannot be purchased as a separate item and is either part of an assembly/kit that can be purchased, or is not available for sale through Multiquip.

SUGGESTED SPARE PARTS

MVC80VH/VHW COMPACTOR WITH HONDA GX160U1SM12 ENGINE

1 to 5 Units

<u>Qty.</u>	<u>P/N</u>	<u>Description</u>
3	070100312	V-BELT
4	939010254	SHOCK ABSORBER
3	9807956846	SPARK PLUG
1	28462ZH8003	ROPE, RECOIL STARTER
3	17210ZE1517	ELEMENT, AIR CLEANER
1	17620Z4H000	CAP, FUEL TANK
1	17672ZE2W01	FUEL FILTER, FUEL TANK

NAMEPLATE AND DECALS

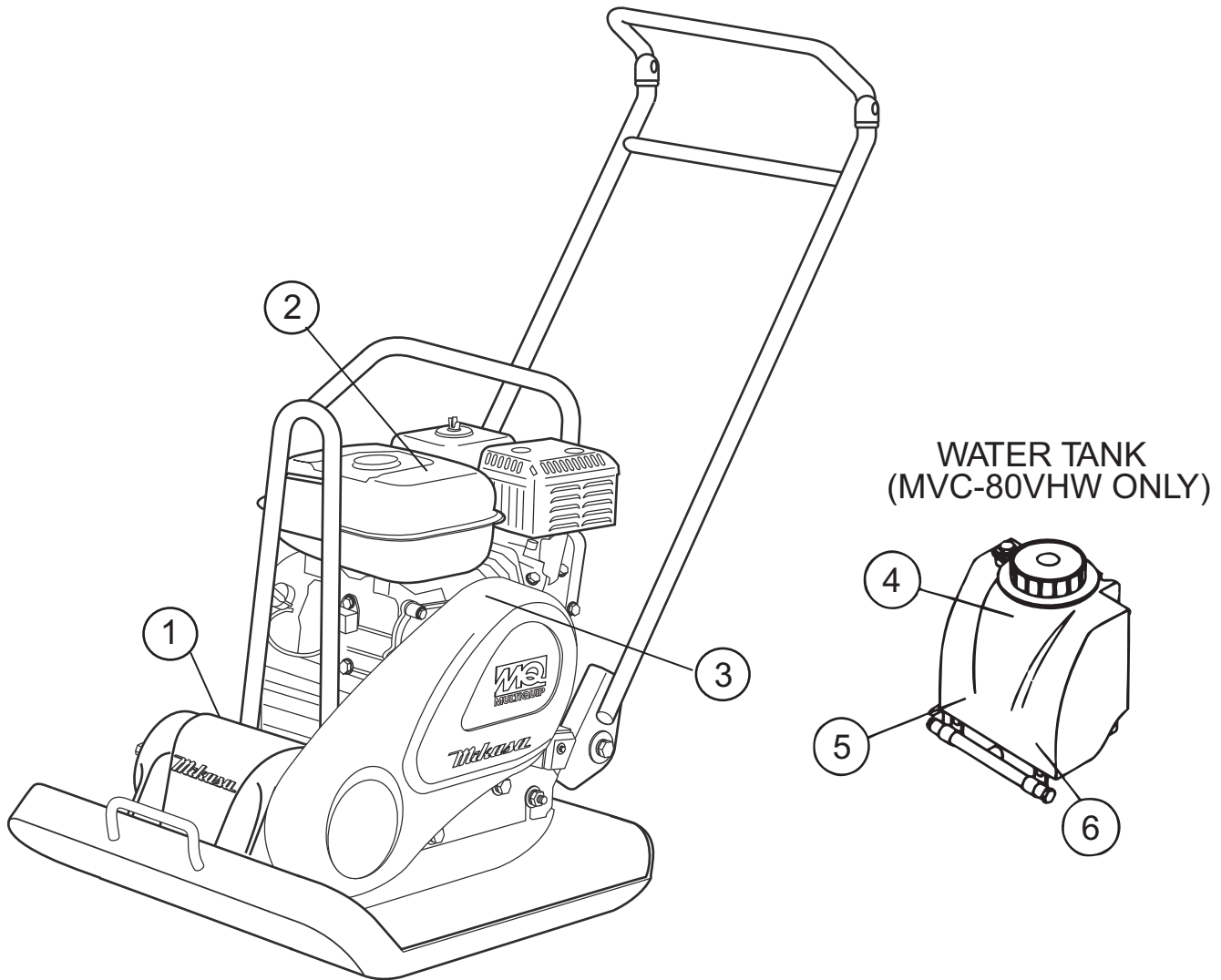

NAMEPLATE AND DECALS

<u>NO</u>	<u>PART NO</u>	<u>PART NAME</u>	<u>QTY.</u>	<u>REMARKS</u>
1		NAMEPLATE, SERIAL NO.	1	CONTACT MQ PARTS DEPT.
2	920203290	DECAL, READ OWNERS MANUAL	1	NPA-329
3	920203989	DECAL, BELT GUARD WARNING	1	NPA-989
4	920101410	DECAL, MIKASA (120 X 60))	1	WATER TANK
5	920201580	DECAL, MQ LOGO (71 X 55)	2	MQ/WATER TANK
6	920105070	DECAL, MIKASA LOGO (125 MM)	1	WATER TANK
8	920201950	DECAL, MOTOR OIL	1	NPA-195
9	920101410	DECAL, MIKASA LOGO (TRIANGLE) ...	1	NPA-141

MAIN BODY ASSY.

MAIN BODY ASSY.

<u>NO</u>	<u>PART NO</u>	<u>PART NAME</u>	<u>QTY.</u>	<u>REMARKS</u>
1	418118530	VIBRATING PLATE 570X450	1	
2	418216501	BASE	1	
3	939010254	SHOCK ABSORBER D45-H41	4	
4	959404350	EARTH WIRE	1	
5	020310080	NUT M10	8	
6	030210250	WASHER, LOCK M10	8	
7	031110160	WASHER, FLAT M10	8	
11	912216004	ENGINE ASSY. GX160U1SM12	1	
12	418457750	BOLT, ENGINE	1	
13	413436870	ENGINE NUT, REAR	1	
14-1	001220840	BOLT 8X40 T	2	
14-2	030208200	WASHER, LOCK M8	2	
14-3	031108160	WASHER, FLAT M8	2	
16	031108160	WASHER, FLAT M8	2	
17	022710809	NYLON NUT M8	1	
18	408421270	CLUTCH SPACER 20.2X25X9.4	1	
19	413332920	CLUTCH ASSY. S-20-A1-124	1	
20	0053005201	KEY 5 X 5 X 35	1	
21	952400130	WASHER 9304	1	
22-1	001220820	BOLT 8 X 20 T	1	
22-2	030208200	WASHER, LOCK M8	1	
23	070100312	V-BELT RPF-3310	1	
25	418216470	BELT COVER	1	
26-1	001221035	BOLT 10X35 T	1	
26-2	030210250	WASHER, LOCK M10	1	
26-3	031110160	WASHER, FLAT M10	1	
27	418216480	BELT COVER (INSIDE)	1	
28-1	001221053	BOLT 10 X 65 T	1	
28-2	030210250	WASHER, LOCK M10	1	
28-3	031110160	WASHER, FLAT M10	1	
29	418343420	COVER SEAL	1	
31	020308060	NUT M8	2	
32	030208200	WASHER, LOCK M8	2	
33	031108160	WASHER, FLAT M8	2	
41	418910070	VIB. PROOF HANDLE ASSY	1	INCLUDES ITEMS W/ #
45	404433430	RUBBER 20X32X28.5/52H	2	
46	952403450	WASHER 11X35X4.5	2	
47-1	001221020	BOLT 10X20 T	2	
47-2	030210250	WASHER, LOCK M10	2	
49	413436720	RUBBER, HANDLE	2	
50	001520845	SOCKET HEAD BOLT 8X45 T	2	
51	020308060	NUT M8	2	
52#	418217060	GRIP, HANDLE	1	
53#	416459340	RUBBER, VIB. PROOF HANDLE	2	
54#	009120407	BOLT, SUNK HEAD 10X20 T	2	
55#	416459320	NUT, VIB. PROOF HANDLE	2	
56#	418217050	VIB. PROOF HANDLE	1	

VIBRATOR ASSY.

VIBRATOR ASSY.

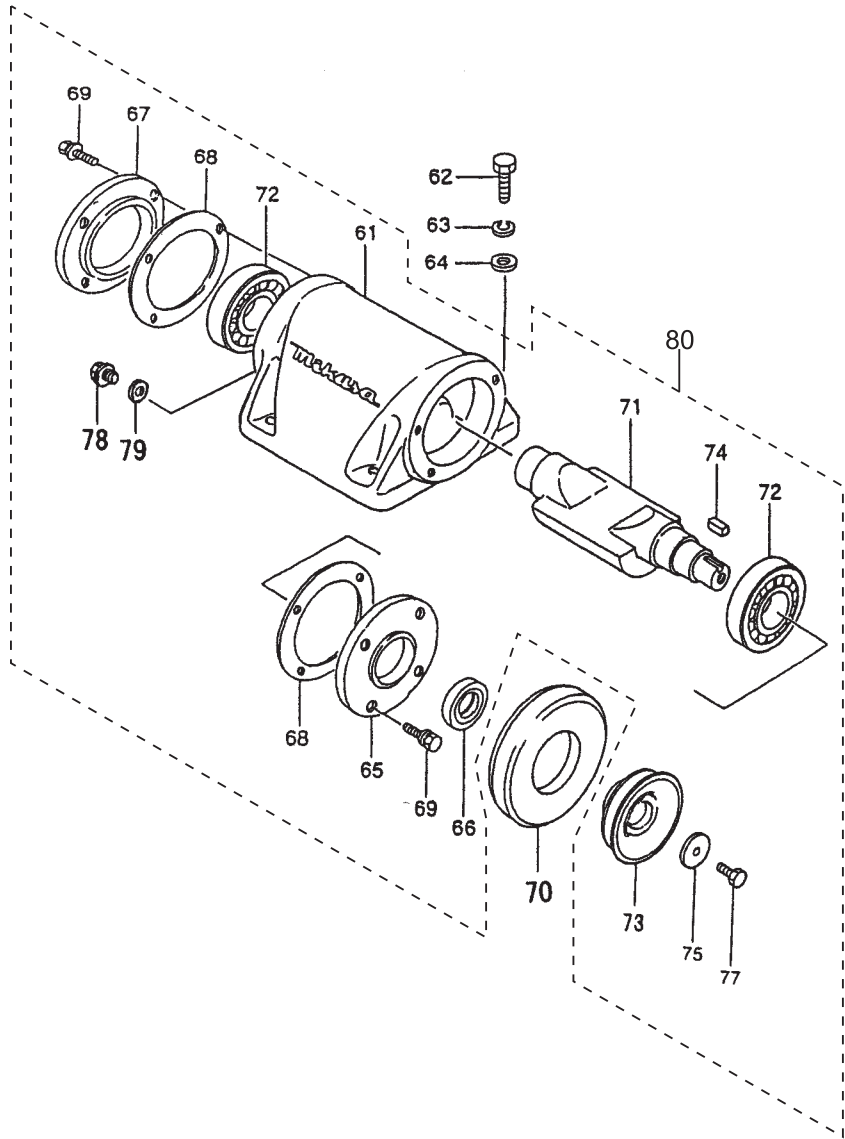

VIBRATOR ASSY.

VIBRATOR ASSY.

<u>NO</u>	<u>PART NO</u>	<u>PART NAME</u>	<u>QTY.</u>	<u>REMARKS</u>
61*	418117730	VIBRATING CASE	1	
62	001221445	BOLT 14X45 T	4	
63	030214350	WASHER, LOCK M14	4	
64	031114260	WASHER, FLAT M14	4	
65*	418456950	CASE COVER/PULLEY	1	
66*	060403020	OIL SEAL TC-30458	1	
67*	418456960	CASE COVER/SHUT-OFF	1	
68*	418456970	PACKING	2	
69*	002400820	BOLT 8X20 SW, PW	8	
70	418456990	COVER SEAL, VIB.	1	
71*	418343630	ECC. ROTOR SHAFT	1	
72*	040306307	BEARING 6307C3	2	
72*	040406307	BEARING 6307C4	2	
73*	418456981	PULLEY, VIBRATOR	1	
74*	951401920	KEY 7X7X30	1	
75*	952403450	WASHER 11X35X4.5	1	
77*	002211030	BOLT 10X30 H, SW	1	
78*	953400270	PLUG 1/4X14 10L	1	
79*	953405260	PACKING	1	
80	418910110	VIBRATOR ASSY	1	INCLUDES ITEMS W/*

WATER TANK ASSY.

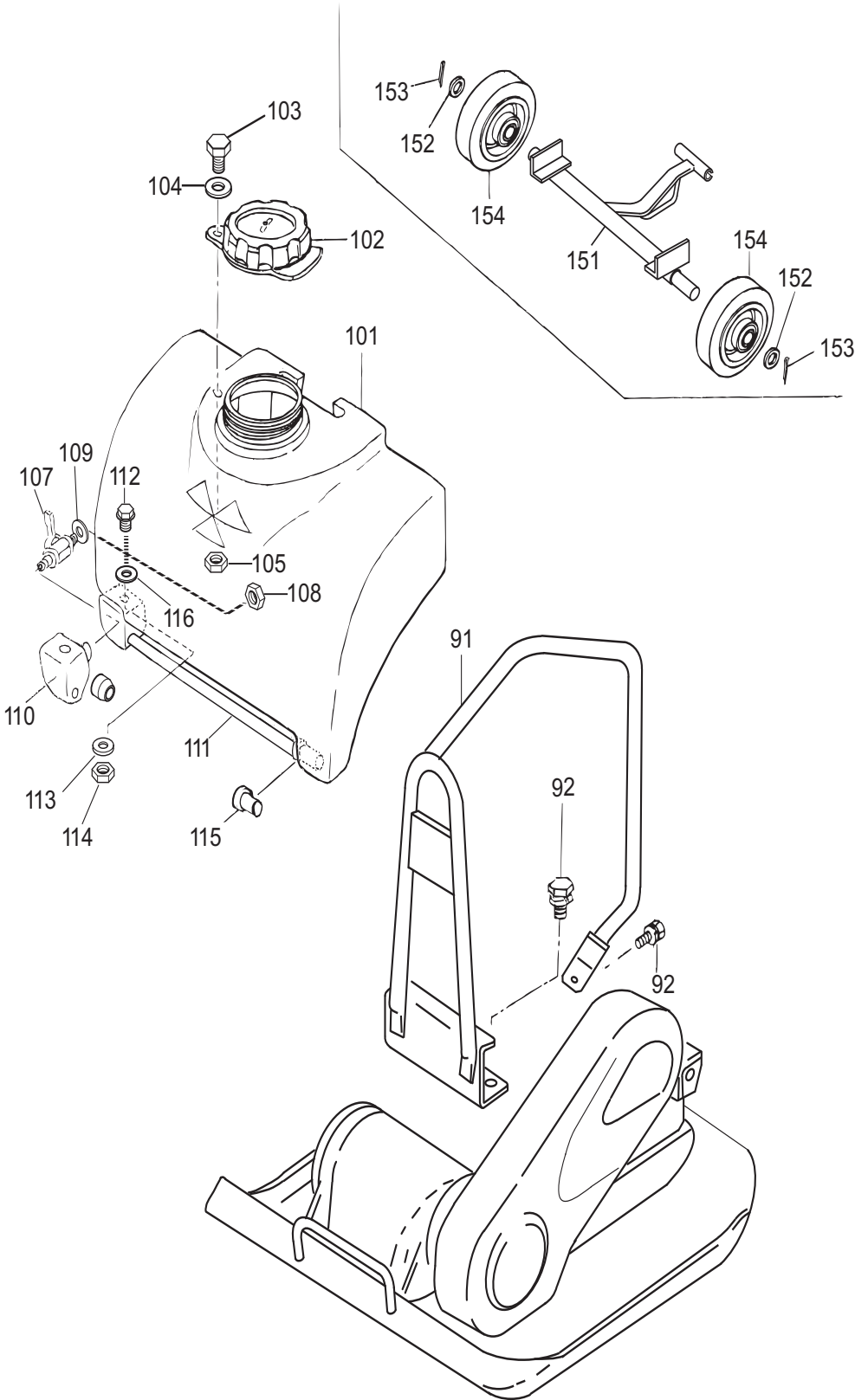

WATER TANK ASSY.

<u>NO</u>	<u>PART NO</u>	<u>PART NAME</u>	<u>QTY.</u>	<u>REMARKS</u>
91	418118580	GUARD HOOK	1	
92	002211025	BOLT 10X25 H, SW	3	
101	418910080	WATER TANK, ORANGE	1	INCLUDES ITEM W/*
102*	954300342	CAP, WATER TANK	1	
103*	001241030	BOLT 10X30 U	1	
104*	033910010	WASHER 10.5X21X2 SUS.	2	
105*	022910180	NYLON NUT M10	1	
107	954403241	COCK PT1/4, BH-1211 AL.	1	
108	959403790	NUT PS-1/4	1	
109	418458320	PACKING 11.5X19.5X2	1	
110	418345150	PIPE HOLDER	1	
111	418345160	SPRINKLING PIPE	1	
112	001740825	FLANGE BOLT 8X2	1	
113	033910110	WASHER, FLAT M8	2	
114	020308064	NUT M8	1	
115	418459330	RUBBER CAP	1	
116	416453780	PACKING 8X19X2T	1	
151	418217120	SHAFT/CARRY	1	
152	031118260	WASHER, FLAT M18	4	
153	025203030	SPLIT COTTER PIN 3X30	2	
154	959300370	WHEEL 200X50	2	

CYLINDER HEAD ASSY.

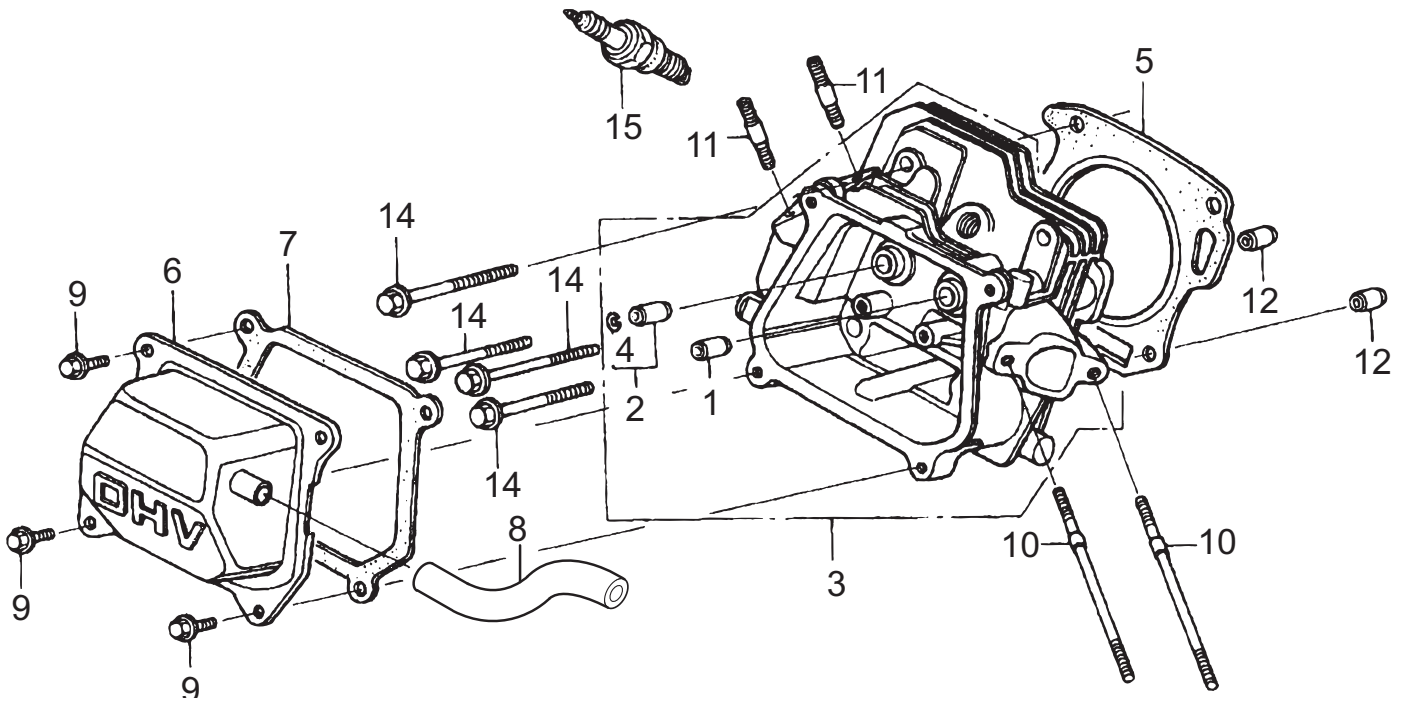

CYLINDER HEAD ASSY.

NO.	PART NO.	PART NAME	QTY.	REMARKS
1%	12204ZE1306	GUIDE, IN. VALVE (OS), OPTIONAL	1	
2%	12205ZE1315	GUIDE, EX. VALVE (OS) OPTIONAL	1	INCLUDES ITEMS W/ #
3	12210ZH8405	HEAD COMP., CYLINDER	1	INCLUDES ITEMS W/ %
4%#	12216ZE5300	CLIP, VALVE GUIDE	1	
5	12251ZH1800	GASKET, CYLINDER HEAD	1	
6	12310ZE1020	COVER, HEAD	1	
7	12391ZE1000	GASKET, CYLINDER HEAD COVER	1	
8	15721ZH8000	TUBE, BREATHER	1	
9	90013883000	BOLT, FLANGE (6 X 12)	4	
10	90043ZE1020	BOLT, STUD (6 X 112)	2	
11	90047ZE1000	BOLT, STUD (8 X 32)	2	
12	9430110160	PIN A, DOWELL (10 X 16)	2	
14	957230806000	BOLT, FLANGE (8 X 55)	4	
15	9807956846	SPARK PLUG BPR6ES (NGK)	1	

CYLINDER BARREL ASSY.

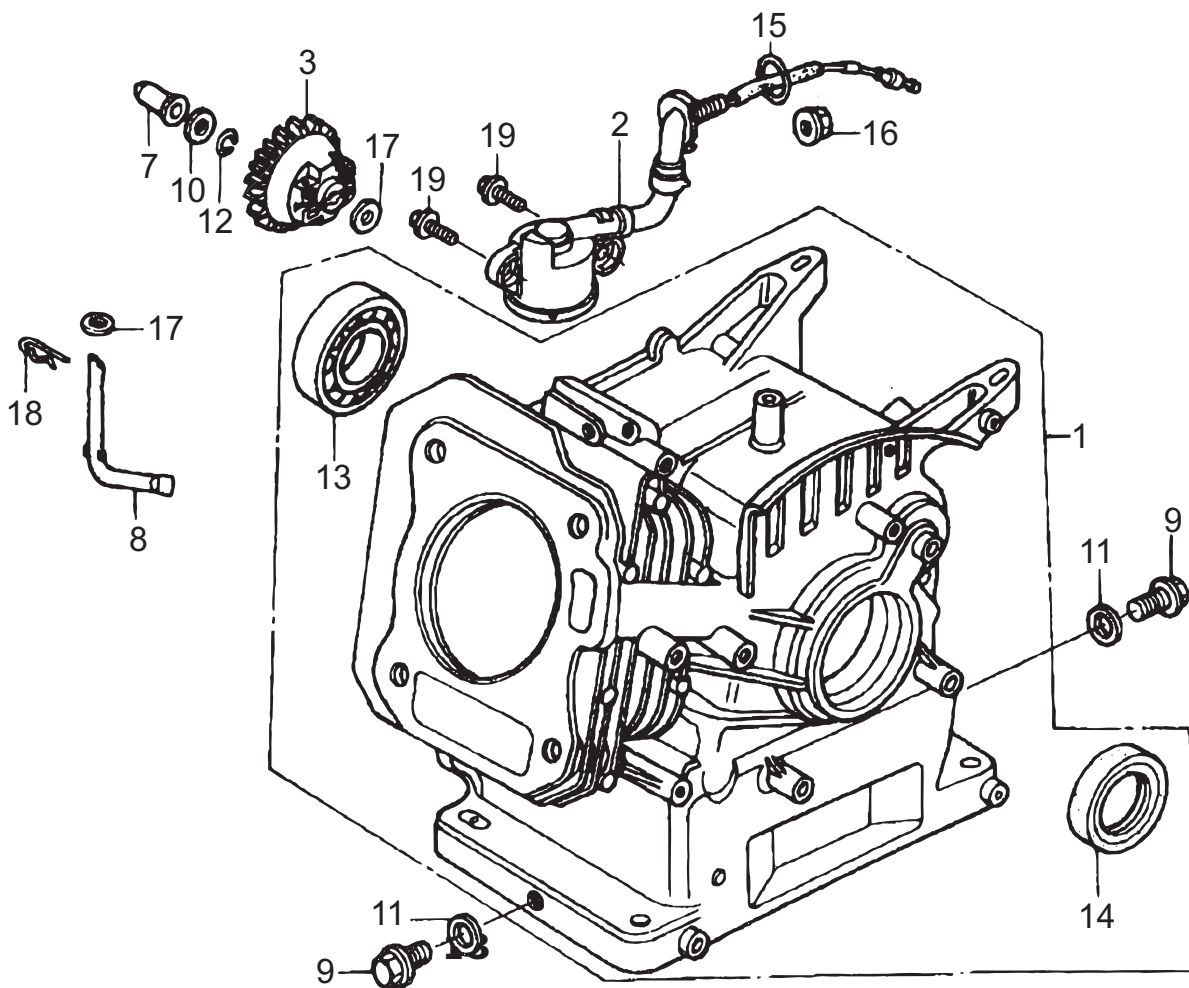

CYLINDER BARREL ASSY.

<u>NO.</u>	<u>PART NO.</u>	<u>PART NAME</u>	<u>QTY.</u>	<u>REMARKS</u>
1	12000ZH8426	CYLINDER BARREL ASSY.	1	INCLUDES ITEMS W/ \$
2	15510ZE1033	SWITCH ASSY., OIL LEVEL	1	
3	16510ZE1000	GOVERNOR ASSY.	1	
7	16531ZE1000	SLIDER, GOVERNOR	1	
8	16541ZE1000	SHAFT, GOVERNOR ARM	1	
9	90131ZE1000	BOLT, DRAIN PLUG	2	
10	90451ZE1000	WASHER, THRUST (6MM)	1	
11	90601ZE1000	WASHER, DRAIN PLUG (10.2MM)	2	
12	90602ZE1000	CLIP, GOVERNOR HOLDER	1	
13\$	91001ZF1003	BEARING, RADIAL BALL (6205)	1	
14\$	91201Z0T801	OIL SEAL (25 X 41 X 6)	1	
15	91353671004	O-RING (14 MM)	1	
16	9405010000	NUT, FLANGE (10MM)	1	
17	9410106800	WASHER, PLAIN (6MM)	2	
18	9425108000	PIN, LOCK (8MM)	1	
19	957010601200	BOLT, FLANGE (6 X 12)	2	

CRANKCASE COVER ASSY.

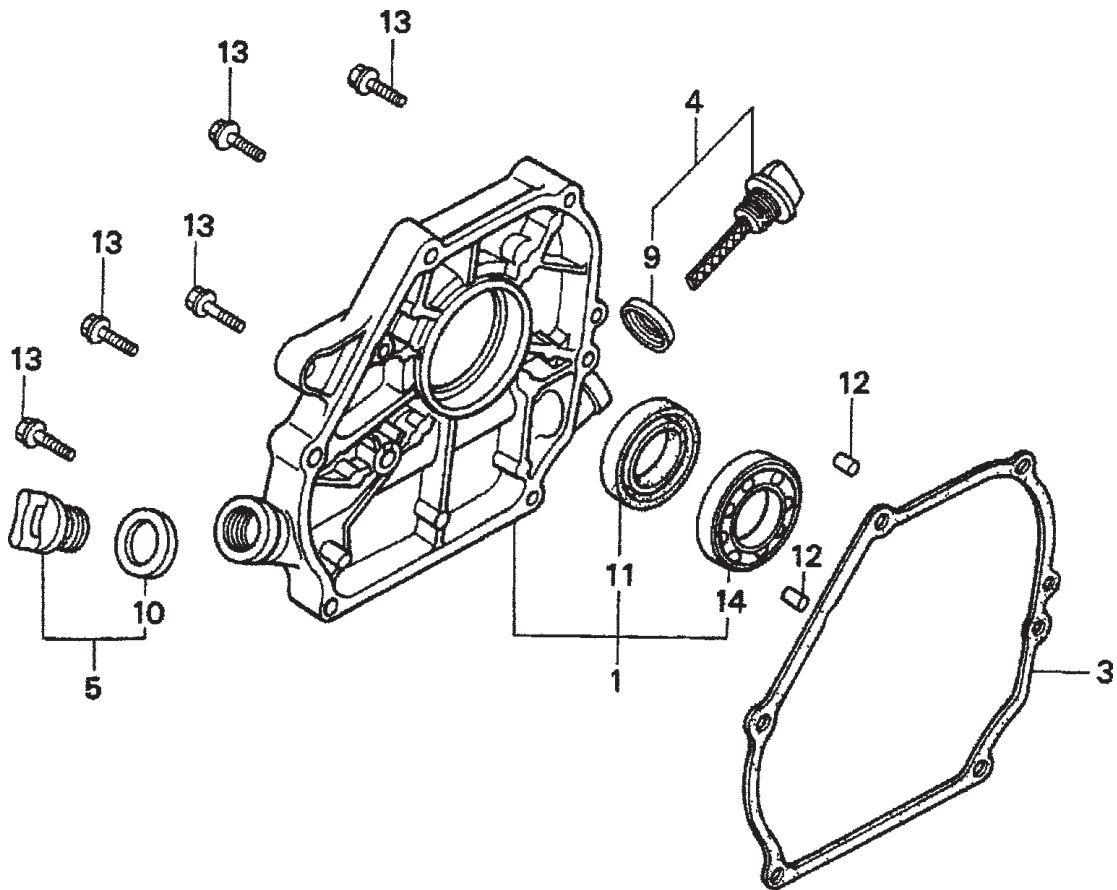

CRANKCASE COVER ASSY.

<u>NO.</u>	<u>PART NO.</u>	<u>PART NAME</u>	<u>QTY.</u>	<u>REMARKS</u>
1	11300ZE1642	COVER ASSY., CRANKCASE	1 INCLUDES ITEMS W/ *
3	11381ZH8801	GASKET, CRANKCASE	1	
4	15600ZE1003	CAP ASSY., OIL FILLER (GRAY)	1 INCLUDES ITEMS W/ #
5	15600ZG4003	CAP ASSY., OIL FILLER	1 INCLUDES ITEMS W/ +
9#	15625ZE1003	GASKET, OIL FILLER CAP	1	
10+	15625ZE1003	GASKET, OIL FILLER CAP	1	
11*	91201Z0T801	OIL SEAL (25 X 41 X 6)	1	
12	9430108140	PIN A, DOWEL (8 X 14)	2	
13	957010803200	BOLT, FLANGE (8 X 32)	6	
14*	961006205000	BEARING, RADIAL BALL (6205)	1	

CRANKSHAFT ASSY.

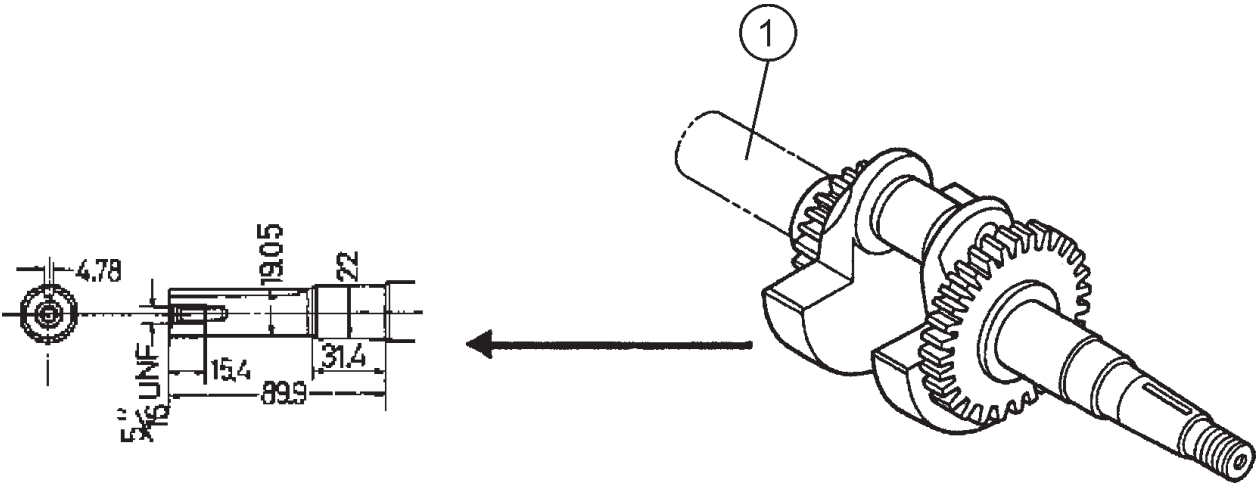

CRANKSHAFT ASSY.

<u>NO.</u>	<u>PART NO.</u>	<u>PART NAME</u>	<u>QTY.</u>	<u>REMARKS</u>
1	13310ZE1000	CRANKSHAFT	1	

PISTON/RINGS ASSY.

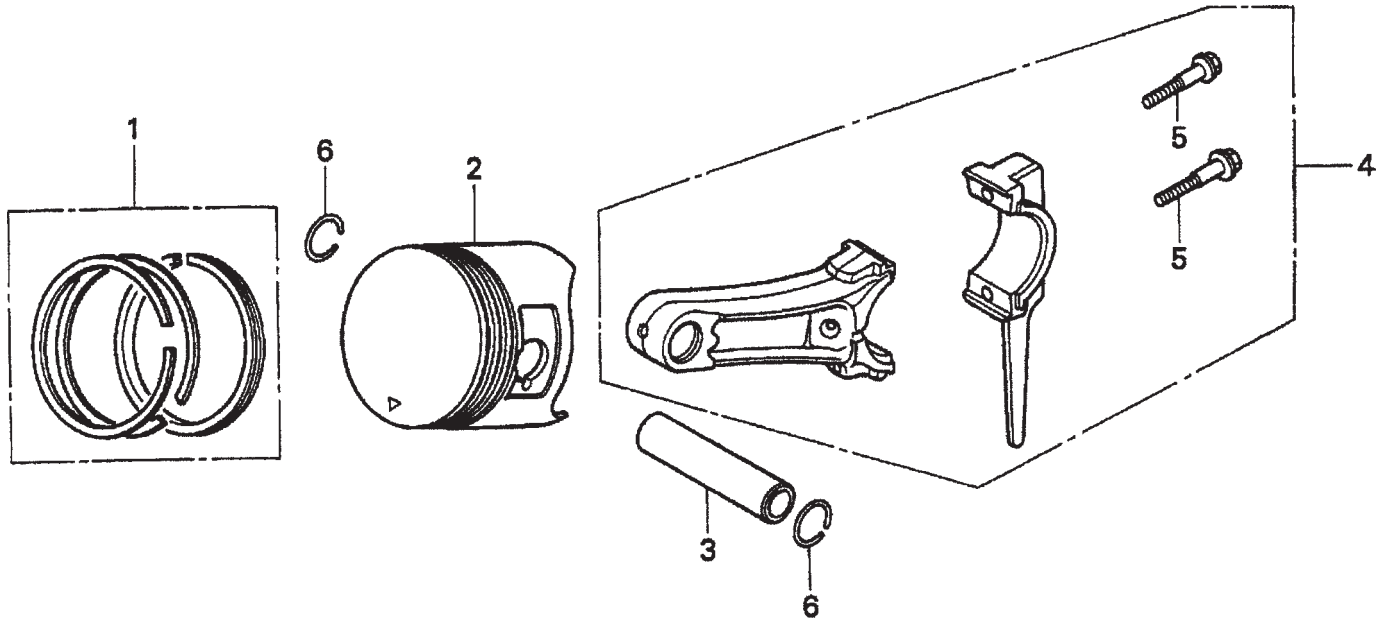

PISTON/RINGS ASSY.

<u>NO.</u>	<u>PART NO.</u>	<u>PART NAME</u>	<u>QTY.</u>	<u>REMARKS</u>
1	13010ZL0003	RING SET, PISTON (STD)	1	
1	13011ZL0003	RING SET, PISTON (OS 0.25)	1	
1	13012ZL0003	RING SET, PISTON (OS 0.50)	1	
1	13013ZL0003	RING SET, PISTON (OS 0.75)	1	
2	13101ZH8010	PISTON (STD)	1	
2	13102ZH8010	PISTON (OS 0.25)	1	
2	13103ZH8010	PISTON (OS 0.50)	1	
2	13104ZH8010	PISTON (0.75)	1	
3	13111ZE1000	PIN, PISTON	1	
4	13200ZE1010	ROD ASSY., CONNECTING	1	INCLUDES ITEMS W/*
5*	90001ZE1000	BOLT, CONNECTING ROD	2	
6	90551ZE1000	CLIP, PISTON PIN (18MM)	2	

CAMSHAFT ASSY.

CAMSHAFT ASSY.

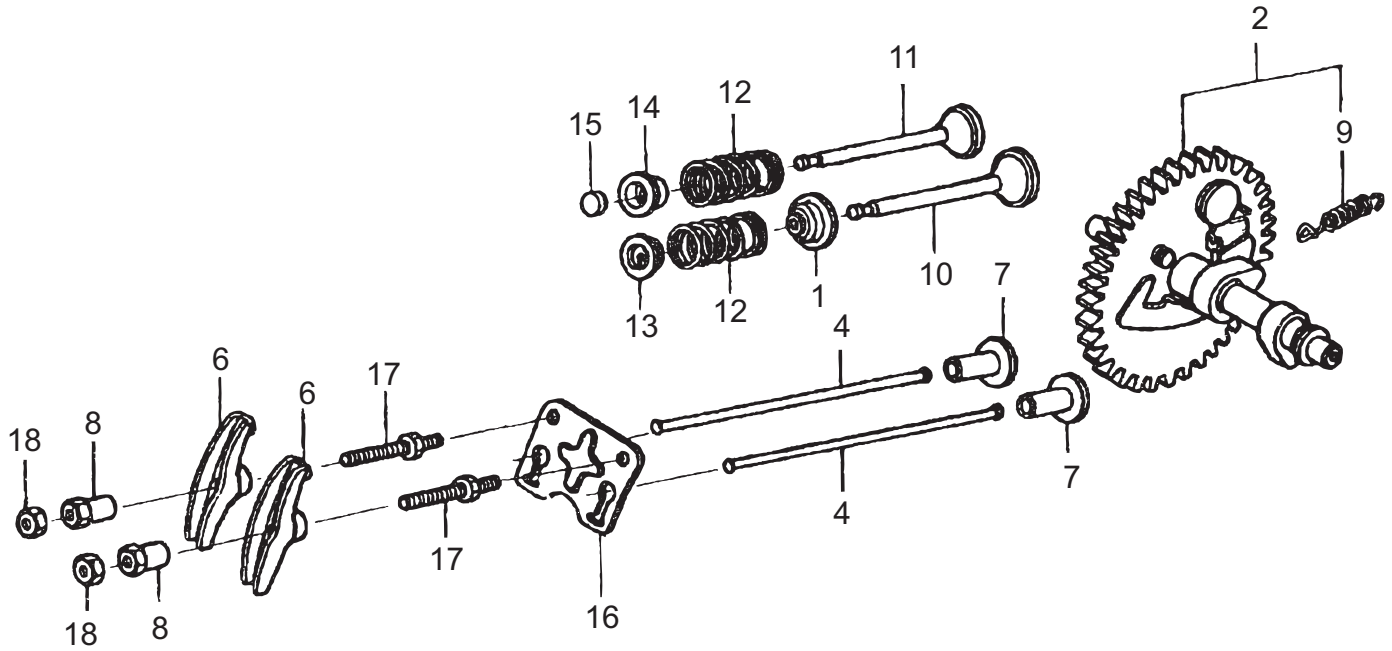

CAMSHAFT ASSY.

CAMSHAFT ASSY.

<u>NO.</u>	<u>PART NO.</u>	<u>PART NAME</u>	<u>QTY.</u>	<u>REMARKS</u>
1	12209ZH8003	SEAL, VALVE STEM	1	
2	14100ZE1812	CAMSHAFT ASSY.	1	INCLUDES ITEMS W/*
4	14410ZE1010	ROD, PUSH	2	
6	14431ZE1000	ARM, VALVE ROCKER	2	
7	14441ZE1010	LIFTER, VALVE	2	
8	14451ZE1013	PIVOT, ROCKER ARM	2	
9*	14568ZE1000	SPRING, WEIGHT RETURN	1	
10	14711ZF1000	VALVE, INLET	1	
11	14721ZF0000	VALVE, EXHAUST	1	
12	14751ZF1000	SPRING VALVE	2	
13	14771ZE1000	RETAINER, IN. VALVE SPRING	1	
14	14773ZE1000	RETAINER, EX. VALVE SPRING	1	
15	14781ZE1000	ROTATOR, VALVE	1	
16	14791ZE1010	PLATE, PUSH ROD GUIDE	1	
17	90012ZE0010	BOLT, PIVOT (8MM)	2	
18	90206ZE1000	NUT, PIVOT ADJ.	2	

RECOIL STARTER ASSY.

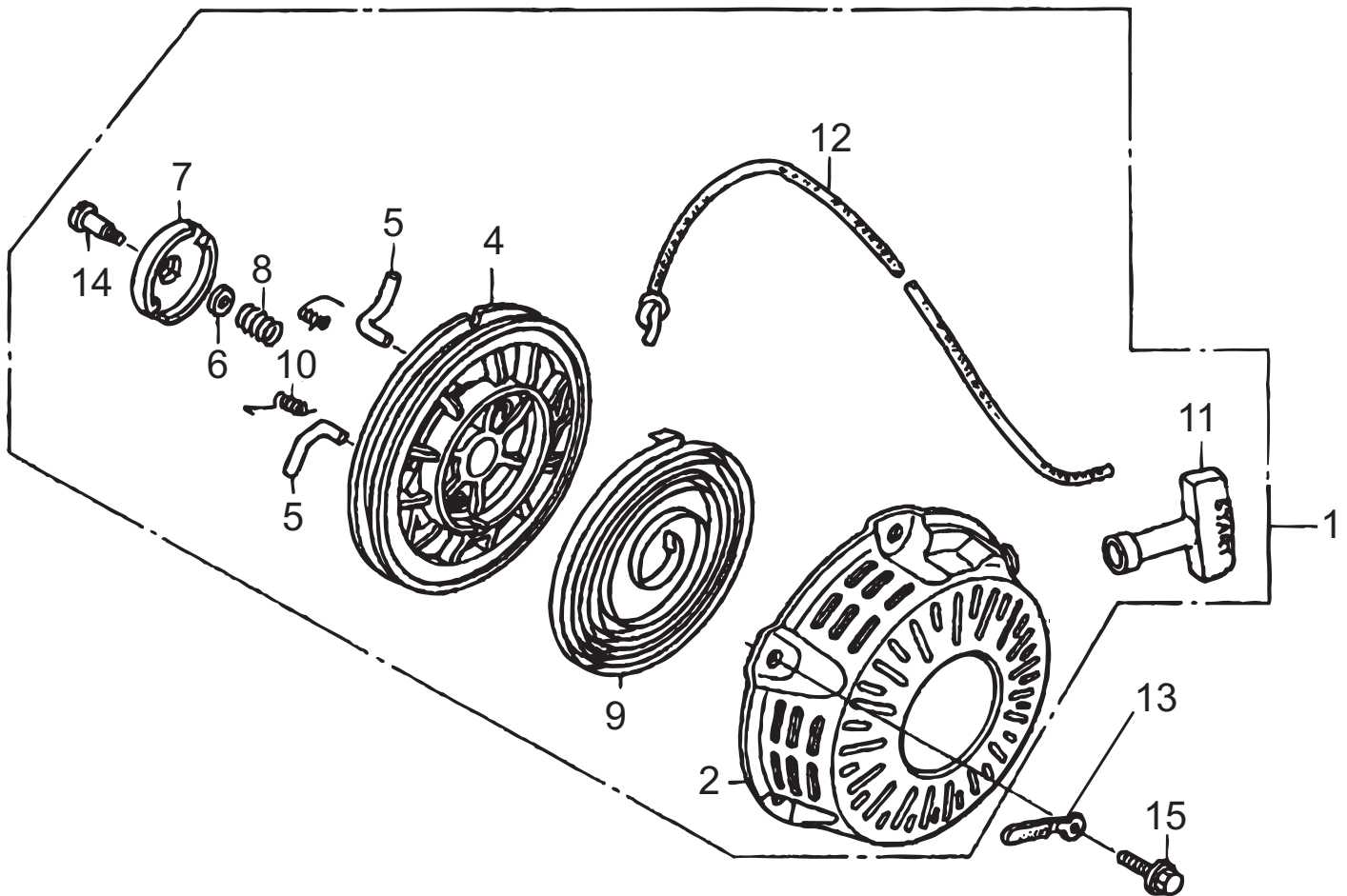

RECOIL STARTER ASSY.

<u>NO.</u>	<u>PART NO.</u>	<u>PART NAME</u>	<u>QTY.</u>	<u>REMARKS</u>
1	28400ZH8023ZB	STARTER ASSY., RECOIL	1 INCLUDES ITEMS W/*
2*	28410ZH8003ZB	CASE, RECOIL STARTER	1	
4*	28421ZH8801	REEL, RECOIL STARTER	1	
5*	28422ZH8801	RATCHET, STARTER	2	
6*	28431ZH8801	PLATE, FRICTION	1	
7*	28433ZH8801	GUIDE, RATCHET	1	
8*	28441ZH8801	SPRING, FRICTION	1	
9*	28442ZH8003	SPRING, RECOIL STARTER	1	
10*	28443ZH8001	SPRING, RETURN	2	
11*	28461ZH8003	KNOB, RECOIL STARTER	1	
12*	28462ZH8003	ROPE, RECOIL STARTER	1	
13	90003ZH8801	CLIP, CORD	1	
14*	90008ZE2003	BOLT, FLANGE (6 X 10)	1	
15	90008ZE2003	BOLT, FLANGE (6 X 10)	1	

FAN COVER ASSY.

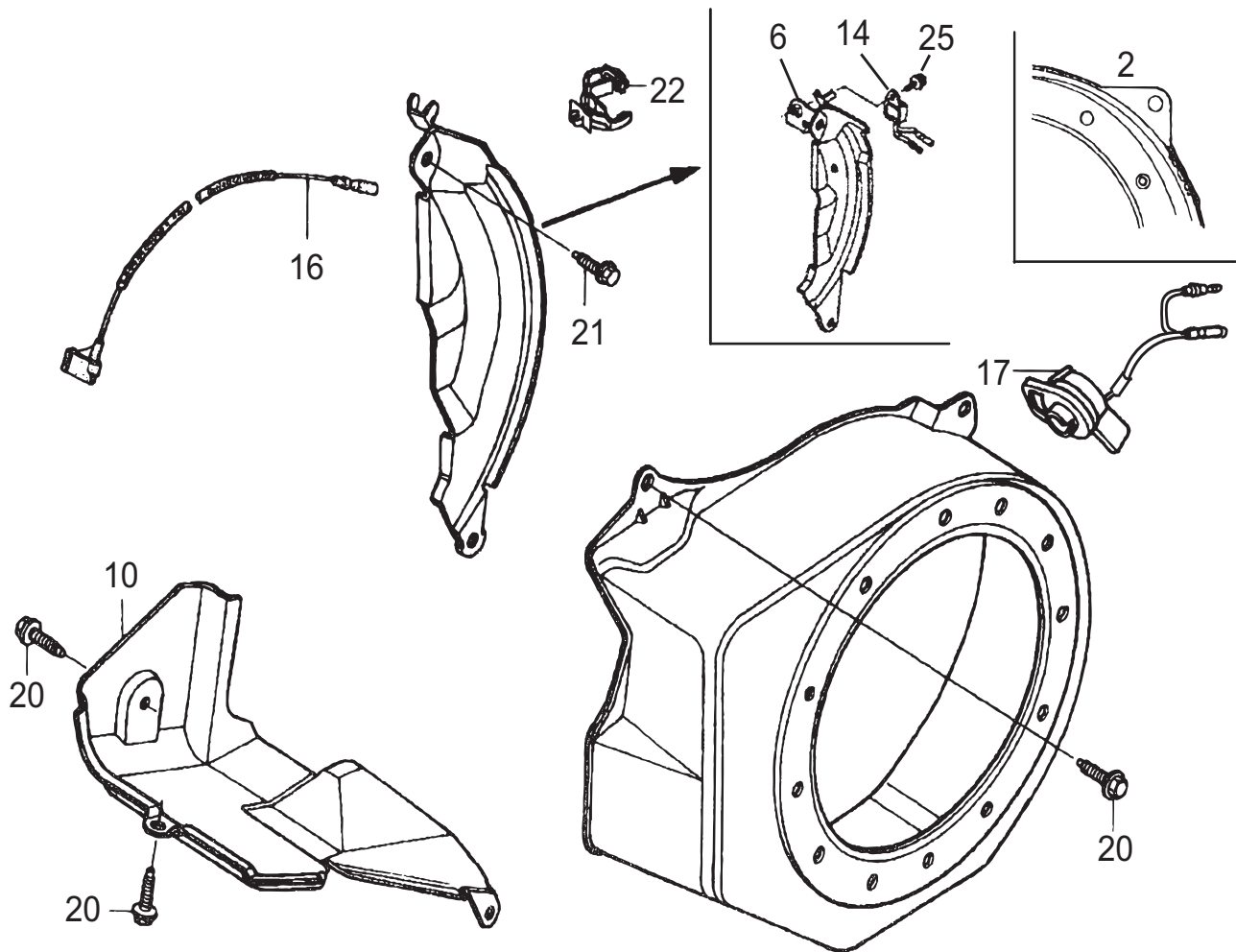

FAN COVER ASSY.

<u>NO.</u>	<u>PART NO.</u>	<u>PART NAME</u>	<u>QTY.</u>	<u>REMARKS</u>
2	19610ZE1000ZC	COVER, FAN (BLACK)	1	
6	19611ZH8810	PLATE, SIDE (OIL ALERT)	1	
10	19630ZH8000	SHROUD	1	
14	34150ZH7003	ALERT UNIT, OIL	1	
16	36101ZE1010	CORD, STOP SWITCH (370MM)	1	
17	36100ZF6P81	SWITCH ASSY., ENGINE STOP	1	
20	90013883000	BOLT, FLANGE (6 X 12)	6	
21	90022888010	BOLT, FLANGE (6 X 20)	1	
22	90601ZH7013	CLIP, HARNESS	1	
25	957010600800	BOLT, FLANGE (6 X 8)	1	

CARBURETOR ASSY.

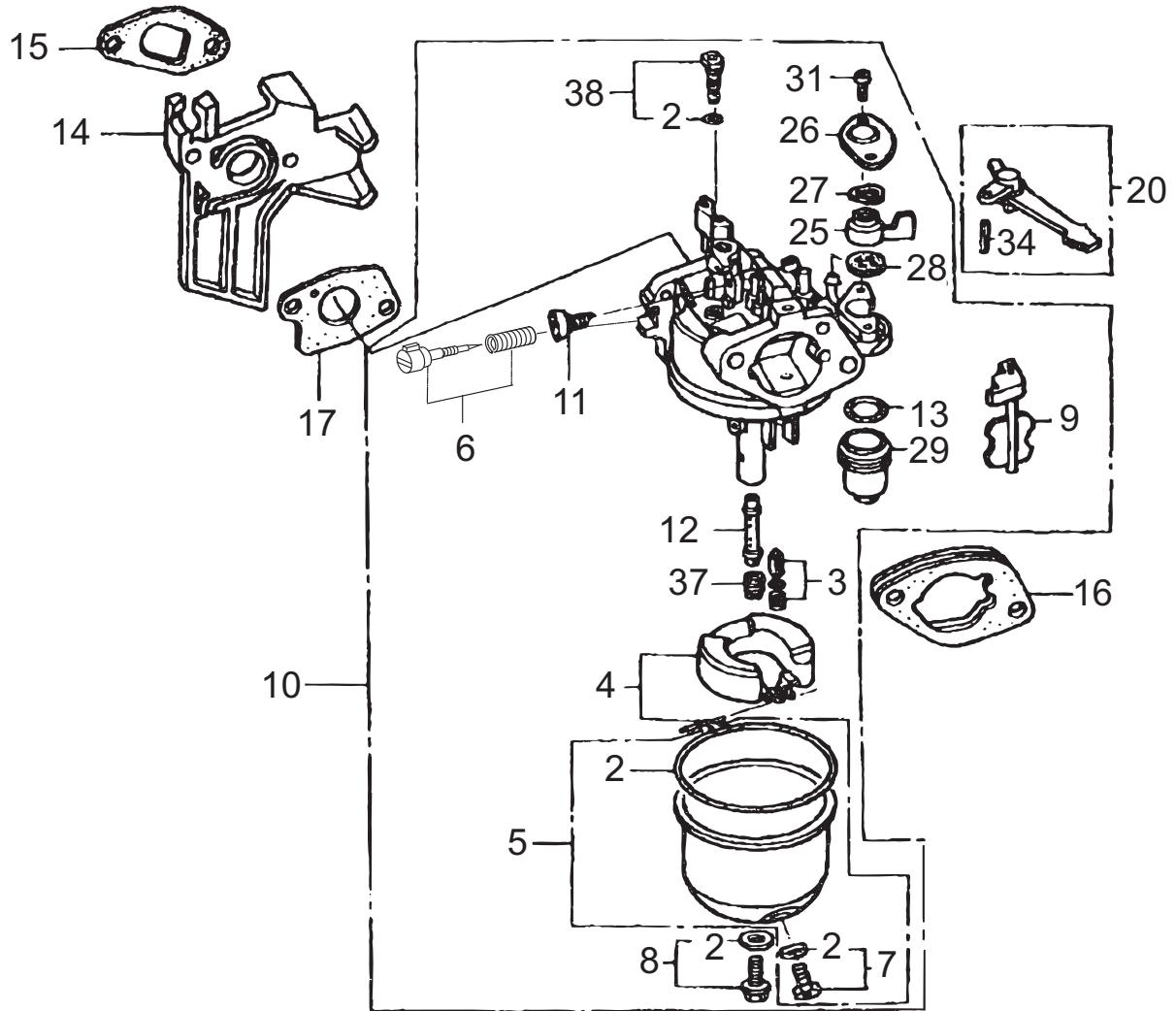

CARBURETOR ASSY.

<u>NO.</u>	<u>PART NO.</u>	<u>PART NAME</u>	<u>QTY.</u>	<u>REMARKS</u>
2*	16010ZE1812	GASKET SET	1	
3*	16011ZE0005	VALVE SET, FLOAT	1	
4*	16013ZE0005	FLOAT SET	1	
5*	16015ZE0831	CHAMBER SET, FLOAT	1 INCLUDES O-RING
6*	16016ZH7W01	SCREW SET	1	
7*	16024ZE1811	SCREW SET, DRAIN	1 INCLUDES GASKET
8*	16028ZE0005	SCREW SET B	1 INCLUDES GASKET
9*	16044ZE0005	CHOKE SET	1	
10	16100ZH8W51	CARBURETOR ASSY. (BE65B B)	1 INCLUDES ITEMS W/ *
11*	16124ZE0005	SCREW, THROTTLE STOP	1	
12*	16166ZH8W50	NOZZLE, MAIN	1	
13*	16173001004	O-RING	1	
14	16211ZE1000	INSULATOR, CARBURETOR	1	
15	16212ZH8800	GASKET, INSULATOR	1	
16	16220ZE1020	SPACER, CARBURETOR	1	
17	16221ZH8801	GASKET, CARBURETOR	1	
20	16610ZE1000	LEVER, CHOKE (STD)	1 INCLUDES ITEMS W/ #
25*	16953ZE1812	LEVER, VALVE	1	
26*	16954ZE1812	PLATE, LEVER SETTING	1	
27*	16956ZE1811	SPRING, VALVE LEVER	1	
28*	16957ZE1812	GASKET, VALVE	1	
29*	16967ZE0811	CUP, FUEL STRAINER	1	
31*	93500030061H	SCREW, PAN (3 X 6)	2	
34#	9430520122	PIN, SPRING (2 X 12)	1	
37*	99101ZH80700	JET, MAIN (#70)	1	
38*	99204ZE00350	JET, SET, PILOT (#35)	1 INCLUDES GASKET

AIR CLEANER ASSY.

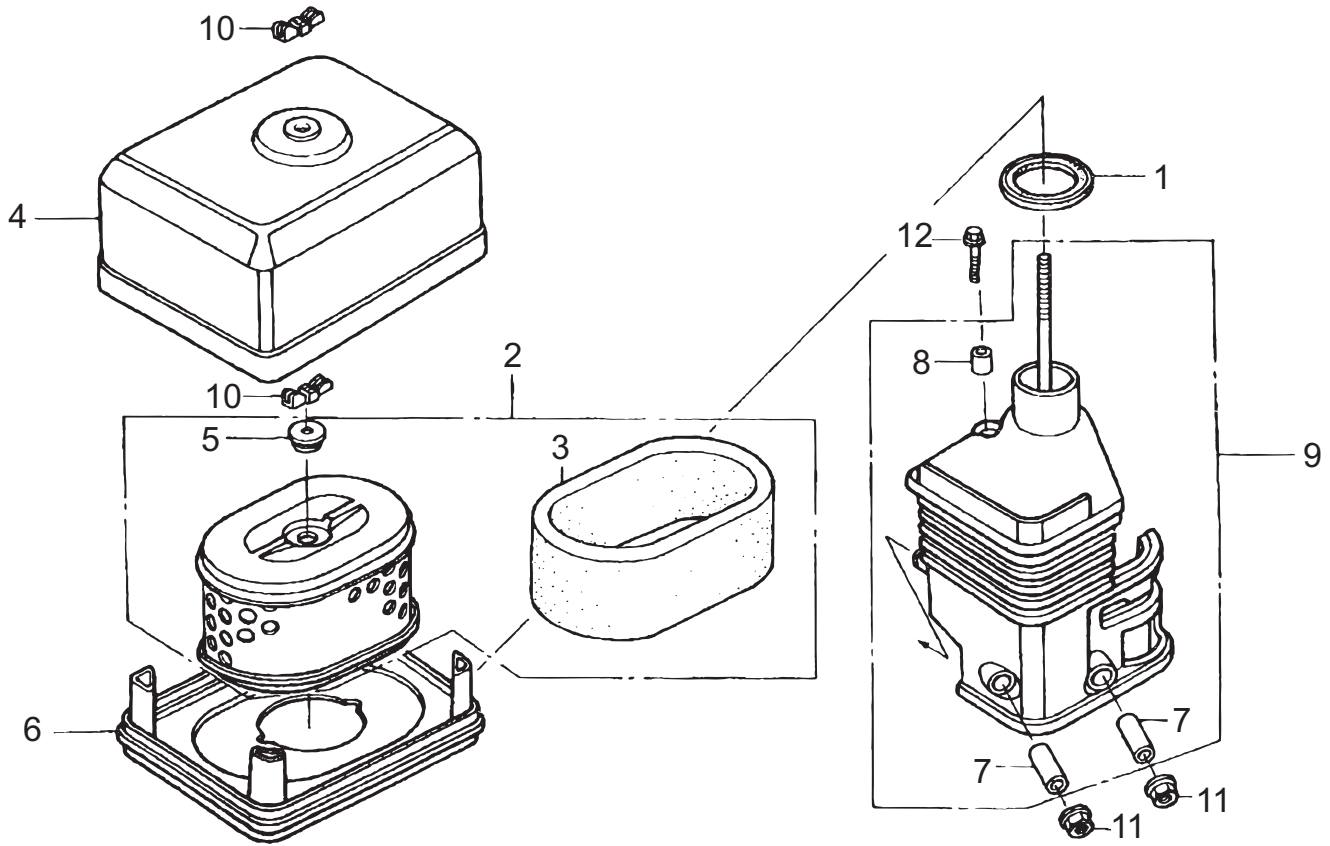

AIR CLEANER ASSY.

<u>NO.</u>	<u>PART NO.</u>	<u>PART NAME</u>	<u>QTY.</u>	<u>REMARKS</u>
1	16271ZE1000	GASKET, ELBOW	1	
2	17210ZE1517	ELEMENT, AIR CLEANER	1	INCLUDES ITEMS W/*
3*	17218ZE1507	FILTER (OUTER)	1	
4	17230ZE1820	COVER, AIR CLEANER	1	
5*	17232891000	GROMMET, AIR CLEANER	1	
6	17235ZE1831	NOISE, MUFFLER	1	
7#	17238ZE7010	COLLAR, AIR CLEANER	2	
8#	17239ZE1000	COLLAR B, AIR CLEANER	1	
9	17410ZE1020	ELBOW, AIR CLEANER	1	INCLUDES ITEMS W/ #
10	90325044000	WINGNUT, TOOL BOX SETTING	1	
11	9405006000	NUT, CAP (6 MM)	2	
12	957010602000	BOLT, FLANGE (6 X 20)	1	

MUFFLER ASSY.

MUFFLER ASSY.

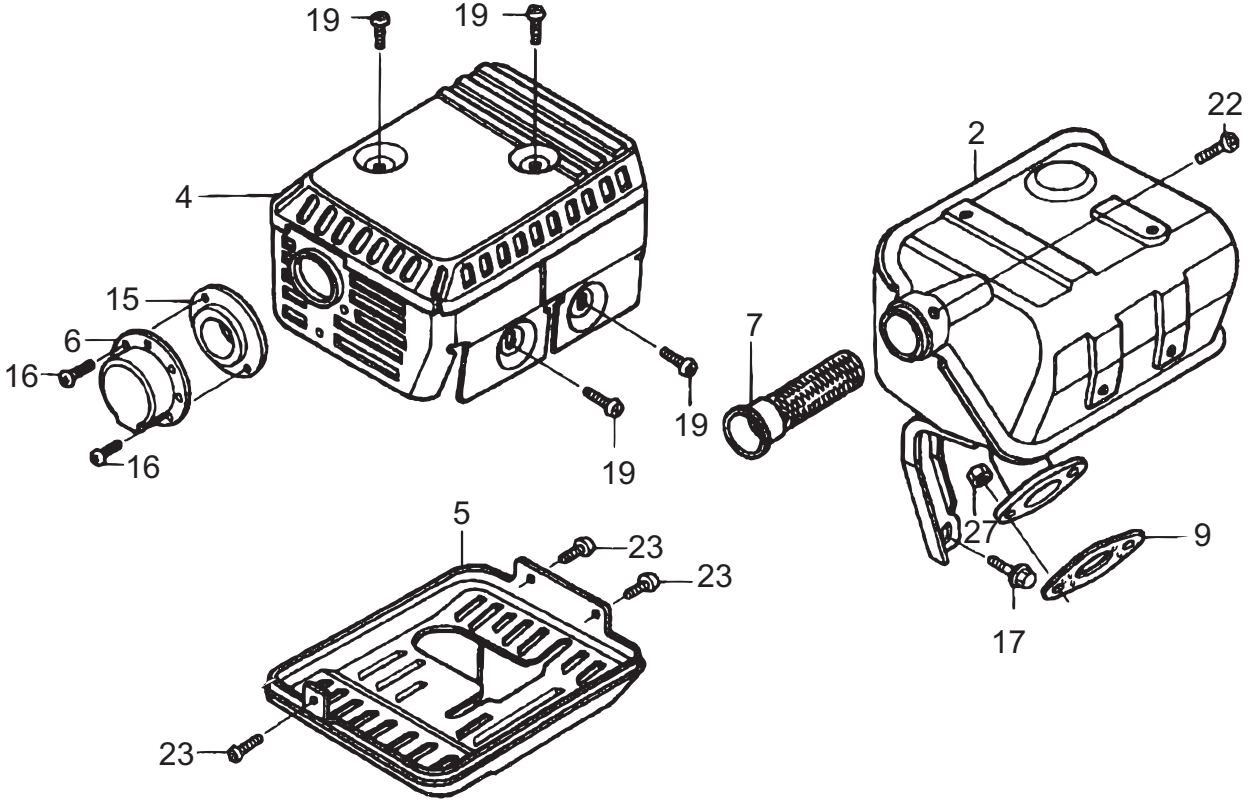

MUFFLER ASSY.

MUFFLER ASSY.

<u>NO.</u>	<u>PART NO.</u>	<u>PART NAME</u>	<u>QTY.</u>	<u>REMARKS</u>
2	18310ZH8810	MUFFLER	1	
4	18320ZF1H01	PROTECTOR, MUFFLER	1	
5	18325ZE1010	PROTECTOR, LOWER	1	
6	18340ZE1010	DEFLECTOR CP	1	
7	18355ZE1000	ARRESTER, SPARK	1	
9	18381ZH8800	GASKET, MUFFLER	1	
15	18522ZE1000	GUIDE, MUFFLER	1	
16	90002ZG0003	SCREW, TAPPING (4 X 8)	2	
17	94001080000S	NUT, HEX (8MM)	2	
19	90050ZE1000	SCREW, TAPPING (5 X 8)	4	
22	90055ZE1000	SCREW, TAPPING (4 X 6)	1	
23	90055ZE1000	SCREW, TAPPING (4 X 6)	4	

FUEL TANK ASSY.

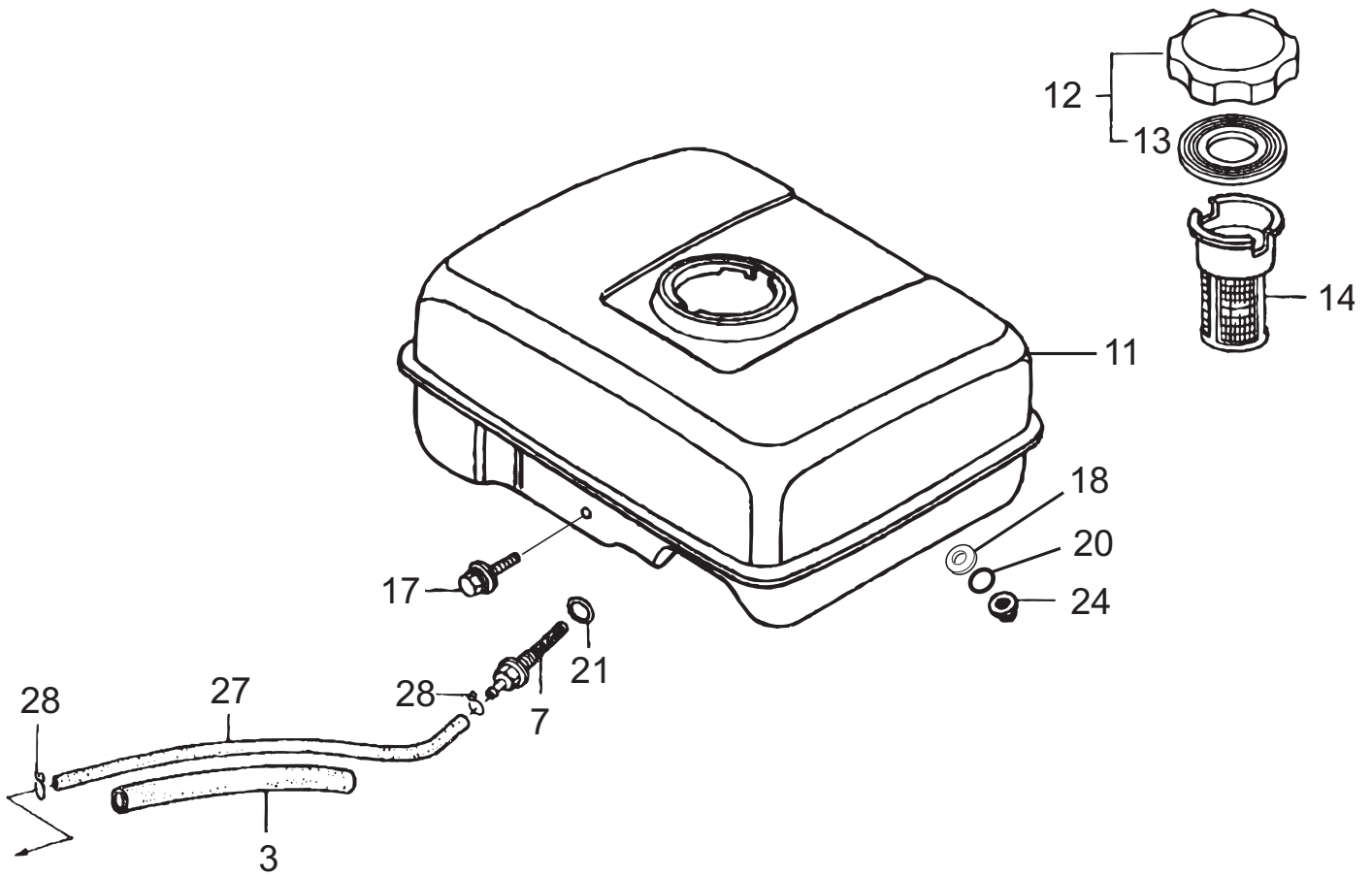

FUEL TANK ASSY.

<u>NO.</u>	<u>PART NO.</u>	<u>PART NAME</u>	<u>QTY.</u>	<u>REMARKS</u>
3	16854ZH8000	RUBBER, SUPPORTER (107MM)	1	
7	16955ZE1000	JOINT, FUEL TANK	1	
11	17510ZE1020ZF	TANK, FUEL (BLACK)	1	
12	17620Z4H000	CAP, FUEL FILLER	1 INCLUDES ITEMS W/ *
13*	17631Z0T812	GASKET, FUEL FILLER CAP	1	
14	17672ZE2W01	FILTER, FUEL	1	
17	90004ZH7003	BOLT, FLANGE (6 X 29)	1	
18	90404680000	WASHER (6.5 X 25 X 1.5)	2	
20	91319ME5003	O-RING (5.5 X 1.4)	2	
21	91353671004	O-RING (14 MM)	1	
24	9405006000	NUT, FLANGE (6MM)	2	
27	950014514040	FUEL TUBE (4.5 X 140)	1	
27	950014500160M	BULK HOSE, FUEL (4.5 X 1M)	1	
28	9500202080	CLIP, TUBE	2	

COOLING FAN AND FLYWHEEL ASSY.

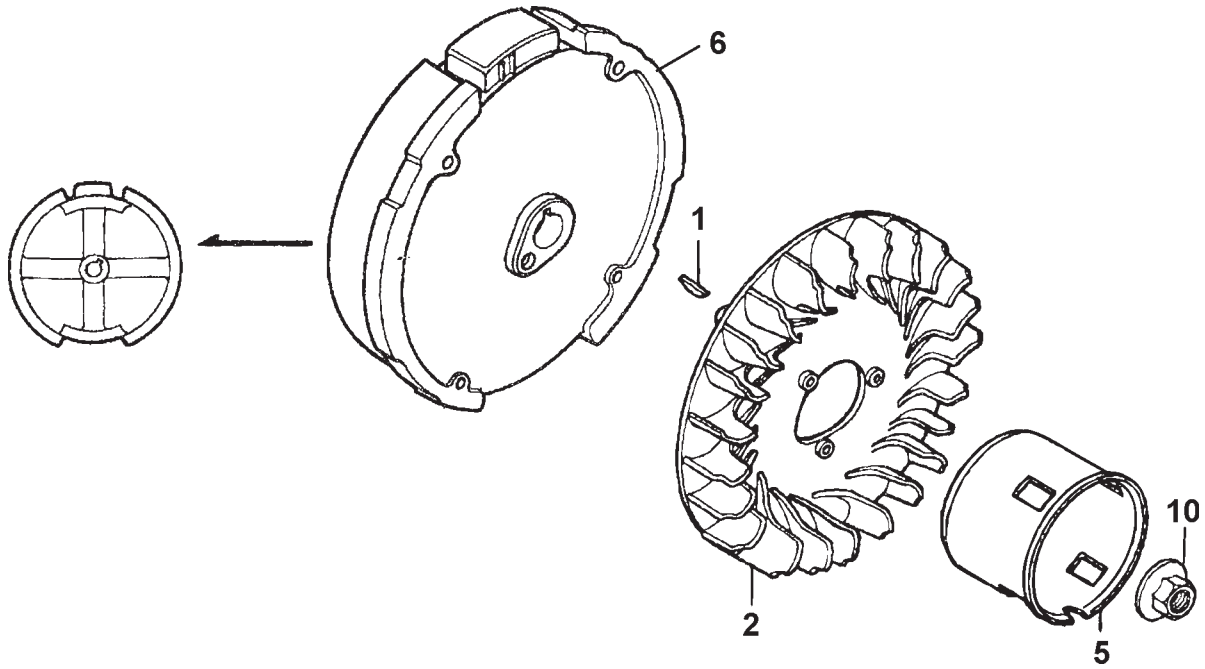

COOLING FAN AND FLYWHEEL ASSY.

<u>NO.</u>	<u>PART NO.</u>	<u>PART NAME</u>	<u>QTY.</u>	<u>REMARKS</u>
1	13331357000	KEY, SPECIAL WOODRUFF (25 X 18)	1	
2	19511ZE1000	FAN, COOLING	1	
5	28451ZH8001	PULLEY, STARTER	1	
6	31100ZE1010	FLYWHEEL	1	
10	90201878003	NUT, SPECIAL (14MM)	1	

IGNITION COIL ASSY.

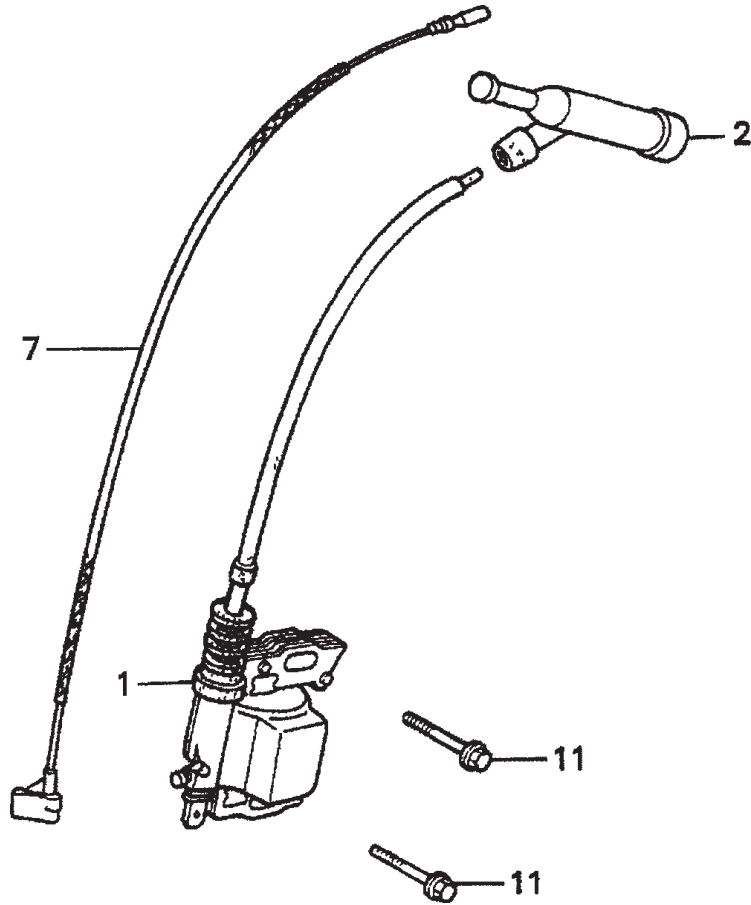

IGNITION COIL ASSY.

<u>NO.</u>	<u>PART NO.</u>	<u>PART NAME</u>	<u>QTY.</u>	<u>REMARKS</u>
1	30500ZE1063	COIL ASSY., IGNITION	1	
2	30700ZE1013	CAP ASSY.	1	
7	36101ZE1010	WIRE, STOP SWITCH (370MM)	1	
11	90121952000	BOLT, FLANGE (6 X 25)	2	

CONTROL ASSY.

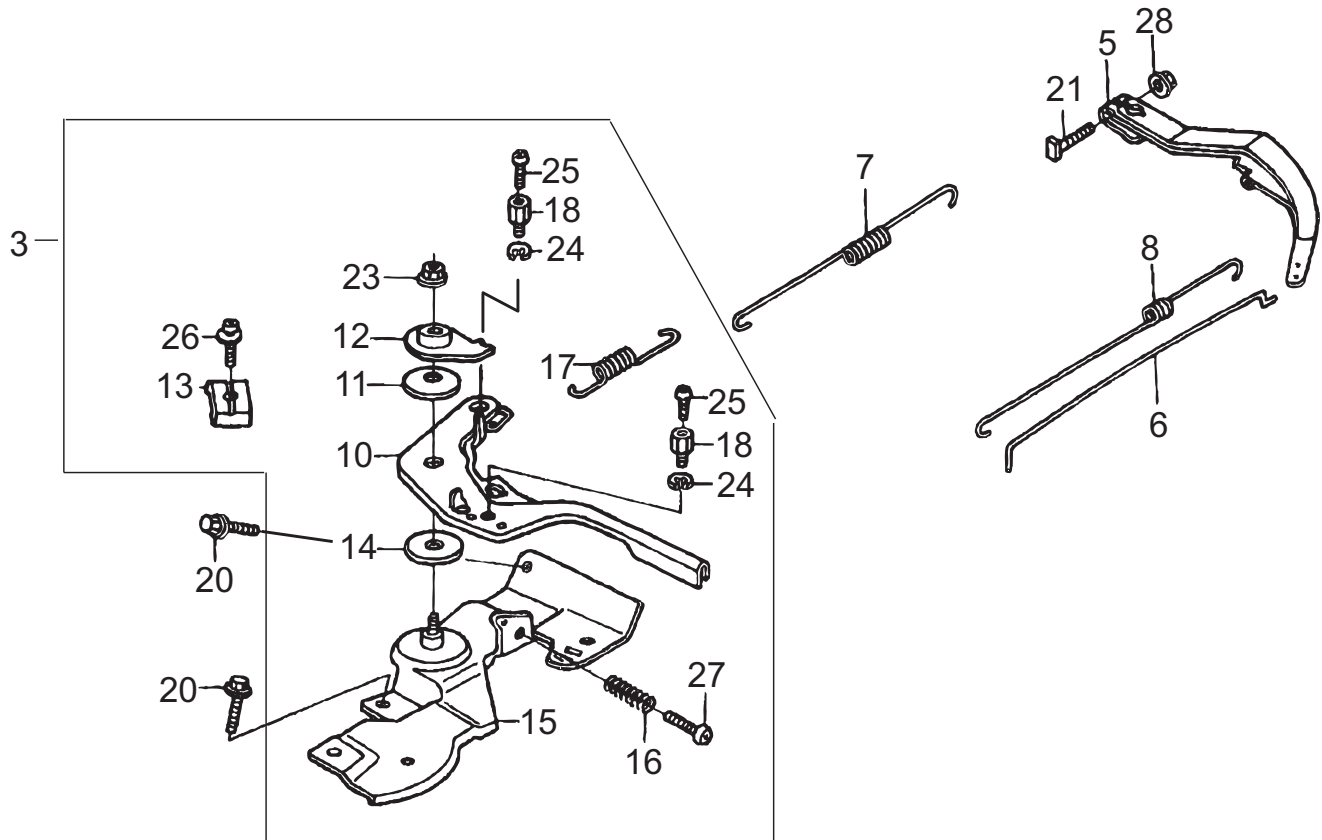

CONTROL ASSY.

<u>NO.</u>	<u>PART NO.</u>	<u>PART NAME</u>	<u>QTY.</u>	<u>REMARKS</u>
3	16500ZH8U43	CONTROL ASSY.	1 INCLUDES ITEMS W/*
5	16551ZE0010	ARM, GOVERNOR	1	
6	16555ZE1000	ROD, GOVERNOR	1	
7	16561ZE1020	SPRING, GOVERNOR	1	
8	16562ZE1020	SPRING, THROTTLE RETURN	1	
10*	16571ZH8020	LEVER CONTROL	1	
11*	16574ZE1000	SPRING LEVER	1	
12*	16575ZH8000	WASHER, CONTROL LEVER	1	
13*	16576891000	HOLDER, CABLE	1	
14*	16578ZE1000	SPACER, CONTROL LEVER	1	
15*	16580ZH8813	BASE CONTROL	1	
16*	16584883300	SPRING, CONTROL ADJUSTING	1	
17*	16592ZE1810	SPRING, CABLE RETURN	1	
18*	16594883010	HOLDER, WIRE	2	
20	90013883000	BOLT, FLANGE (6 X 12)	2	
21	90015ZE5010	BOLT, GOVERNOR ARM	1	
23*	90114SA0000	NUT, SELF-LOCK (6MM)	1	
24*	90605230000	CIRCLIP	2	
25*	93500040060H	SCREW, PAN (4 X 6)	2	
26*	93500050160A	SCREW, PAN (5 X 16)	1	
27*	93500050250H	SCREW, PAN (5 X 25)	1	
28	9405006000	NUT, FLANGE (6MM)	1	

LABELS ASSY.

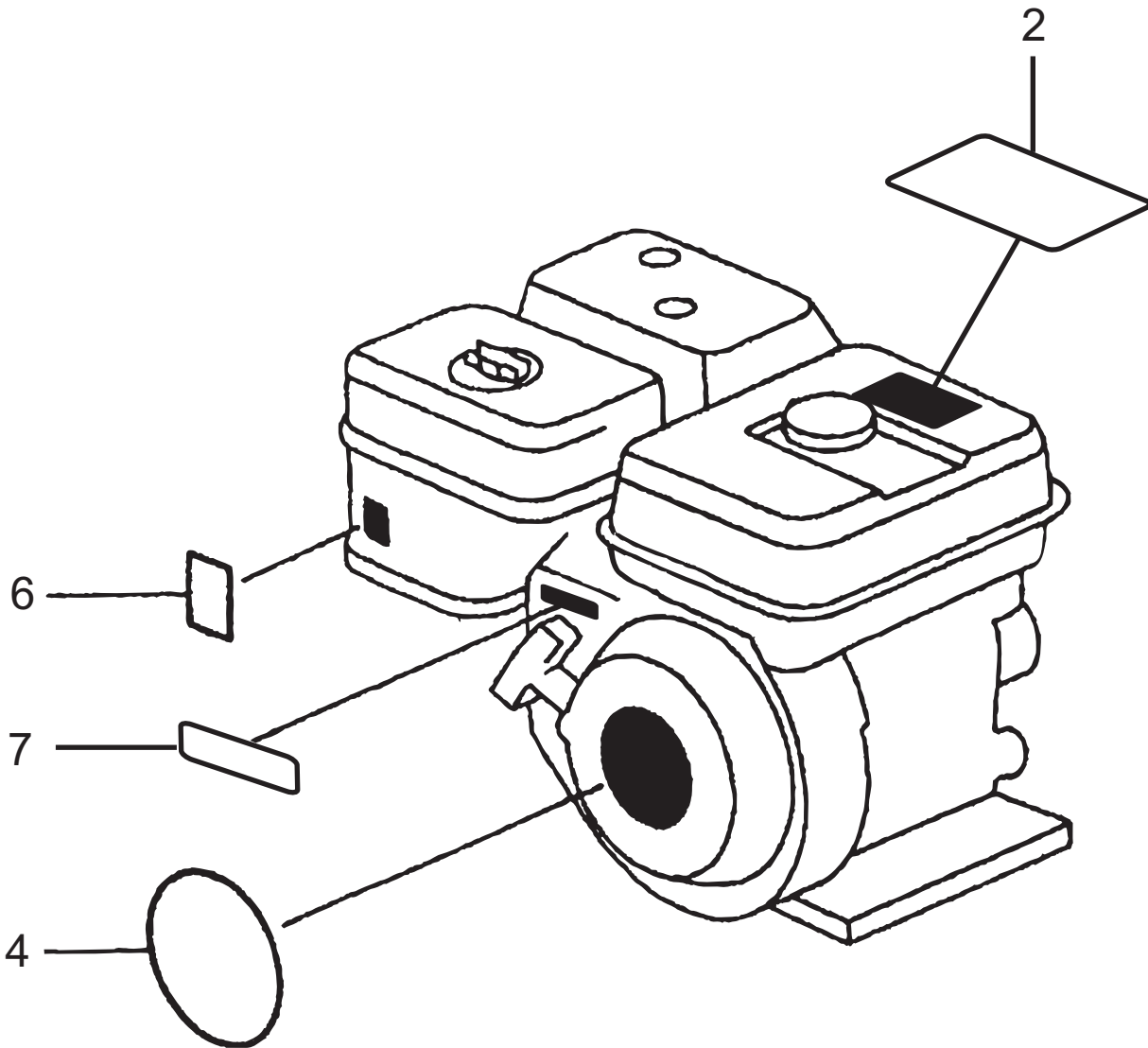

LABELS ASSY.

<u>NO.</u>	<u>PART NO.</u>	<u>PART NAME</u>	<u>QTY.</u>	<u>REMARKS</u>
2	87516ZH7000	MARK, OPERATOR CAUTION	1	
4	87521ZH8030	EMBLEM (5.5)	1	
6	87528ZH7000	MARK, CHOKE (GRAY)	1	
7	87532ZH7000	MARK, THROTTLE INDICATION	1	

TERMS AND CONDITIONS OF SALE — PARTS

PAYMENT TERMS

Terms of payment for parts are net 30 days.

FREIGHT POLICY

All parts orders will be shipped collect or prepaid with the charges added to the invoice. All shipments are F.O.B. point of origin. Multiquip's responsibility ceases when a signed manifest has been obtained from the carrier, and any claim for shortage or damage must be settled between the consignee and the carrier.

MINIMUM ORDER

The minimum charge for orders from Multiquip is \$15.00 net. Customers will be asked for instructions regarding handling of orders not meeting this requirement.

RETURNED GOODS POLICY

Return shipments will be accepted and credit will be allowed, subject to the following provisions:

1. A Returned Material Authorization must be approved by Multiquip prior to shipment.
2. To obtain a Return Material Authorization, a list must be provided to Multiquip Parts Sales that defines item numbers, quantities, and descriptions of the items to be returned.
 - a. The parts numbers and descriptions must match the current parts price list.
 - b. The list must be typed or computer generated.
 - c. The list must state the reason(s) for the return.
 - d. The list must reference the sales order(s) or invoice(s) under which the items were originally purchased.
 - e. The list must include the name and phone number of the person requesting the RMA.
3. A copy of the Return Material Authorization must accompany the return shipment.
4. Freight is at the sender's expense. All parts must be returned freight prepaid to Multiquip's designated receiving point.

5. Parts must be in new and resalable condition, in the original Multiquip package (if any), and with Multiquip part numbers clearly marked.
6. The following items are not returnable:
 - a. Obsolete parts. (If an item is in the price book and shows as being replaced by another item, it is obsolete.)
 - b. Any parts with a limited shelf life (such as gaskets, seals, "O" rings, and other rubber parts) that were purchased more than six months prior to the return date.
 - c. Any line item with an extended dealer net price of less than \$5.00.
 - d. Special order items.
 - e. Electrical components.
 - f. Paint, chemicals, and lubricants.
 - g. Decals and paper products.
 - h. Items purchased in kits.
7. The sender will be notified of any material received that is not acceptable.
8. Such material will be held for five working days from notification, pending instructions. If a reply is not received within five days, the material will be returned to the sender at his expense.
9. Credit on returned parts will be issued at dealer net price at time of the original purchase, less a 15% restocking charge.
10. In cases where an item is accepted, for which the original purchase document can not be determined, the price will be based on the list price that was effective twelve months prior to the RMA date.
11. Credit issued will be applied to future purchases only.

PRICING AND REBATES

Prices are subject to change without prior notice. Price changes are effective on a specific date and all orders received on or after that date will be billed at the revised price. Rebates for price declines and added charges for price increases will not be made for stock on hand at the time of any price change.

Multiquip reserves the right to quote and sell direct to Government agencies, and to Original Equipment Manufacturer accounts who use our products as integral parts of their own products.

SPECIAL EXPEDITING SERVICE

A \$35.00 surcharge will be added to the invoice for special handling including bus shipments, insured parcel post or in cases where Multiquip must personally deliver the parts to the carrier.

LIMITATIONS OF SELLER'S LIABILITY

Multiquip shall not be liable hereunder for damages in excess of the purchase price of the item with respect to which damages are claimed, and in no event shall Multiquip be liable for loss of profit or good will or for any other special, consequential or incidental damages.

LIMITATION OF WARRANTIES

No warranties, express or implied, are made in connection with the sale of parts or trade accessories nor as to any engine not manufactured by Multiquip. Such warranties made in connection with the sale of new, complete units are made exclusively by a statement of warranty packaged with such units, and Multiquip neither assumes nor authorizes any person to assume for it any other obligation or liability whatever in connection with the sale of its products. Apart from such written statement of warranty, there are no warranties, express, implied or statutory, which extend beyond the description of the products on the face hereof.

Effective: February 22, 2006

OPERATION AND PARTS MANUAL

HERE'S HOW TO GET HELP

PLEASE HAVE THE MODEL AND SERIAL
NUMBER ON-HAND WHEN CALLING

UNITED STATES

Multiquip Corporate Office

18910 Wilmington Ave. Tel. (800) 421-1244
Carson, CA 90746 Fax (800) 537-3927
Contact: mq@multiquip.com

Service Department

800-421-1244 Fax: 310-537-4259
310-537-3700

Technical Assistance

800-478-1244 Fax: 310-943-2238

MQ Parts Department

800-427-1244 Fax: 800-672-7877
310-537-3700 Fax: 310-637-3284

Warranty Department

800-421-1244 Fax: 310-943-2249
310-537-3700

MEXICO

MQ Cipsa

Carr. Fed. Mexico-Puebla KM 126.5 Tel: (52) 222-225-9900
Momoxpan, Cholula, Puebla 72760 Mexico Fax: (52) 222-285-0420
Contact: pmastretta@cipsa.com.mx

CANADA

Multiquip

4110 Industriel Boul. Tel: (450) 625-2244
Laval, Quebec, Canada H7L 6V3 Tel: (877) 963-4411
Contact: jmartin@multiquip.com Fax: (450) 625-8664

UNITED KINGDOM

Multiquip (UK) Limited Head Office

Unit 2, Northpoint Industrial Estate, Tel: 0161 339 2223
Globe Lane, Fax: 0161 339 3226
Dukinfield, Cheshire SK16 4UJ
Contact: sales@multiquip.co.uk

© COPYRIGHT 2011, MULTIQUIP INC.

Multiquip Inc, the MQ logo and the Mikasa logo are registered trademarks of Multiquip Inc. and may not be used, reproduced, or altered without written permission. All other trademarks are the property of their respective owners and used with permission.

This manual MUST accompany the equipment at all times. This manual is considered a permanent part of the equipment and should remain with the unit if resold.

The information and specifications included in this publication were in effect at the time of approval for printing. Illustrations, descriptions, references and technical data contained in this manual are for guidance only and may not be considered as binding. Multiquip Inc. reserves the right to discontinue or change specifications, design or the information published in this publication at any time without notice and without incurring any obligations.

Your Local Dealer is:



Free Manuals Download Website

<http://myh66.com>

<http://usermanuals.us>

<http://www.somanuals.com>

<http://www.4manuals.cc>

<http://www.manual-lib.com>

<http://www.404manual.com>

<http://www.luxmanual.com>

<http://aubethermostatmanual.com>

Golf course search by state

<http://golfingnear.com>

Email search by domain

<http://emailbydomain.com>

Auto manuals search

<http://auto.somanuals.com>

TV manuals search

<http://tv.somanuals.com>