



**SERIES MC-900 MURPHYMATIC®
MANUAL GENERATOR
ENGINE CONTROL SYSTEM
DESIGN, INSTALLATION
AND OPERATING MANUAL**



Table of Contents

Section 1: Introduction	<i>page 1</i>
1-1 System	1
1-2 Models	1
1-3 Purpose	1
1-4 Definitions	1
1-5 How To Use This Manual	1
Section 2: Specifications	1
2-1 Enclosure Type	1
2-2 Power Requirements	1
2-3 Input Ratings	1
2-4 Output Ratings	1
2-5 Field Wiring Connections	1
2-6 Operating Temperature	1
Section 3: Model Identification	1
3-1 Model Numbers	1
3-2 MC-900	2
3-3 MC-900-2	3
Section 4: Installation	3
4-1 Location	3
4-2 Wiring	3
4-3 Overspeed Switch	7
4-4 Pre-Operational Check-Out	7
Section 5: Operation	8
5-1 Operator Controls	8
5-2 Operating Modes	8
Section 6: Routine Maintenance and Operational Tests	8
6-1 Routine Maintenance	8
6-2 Operational Tests	8
Section 7: Troubleshooting and Repair	8
7-1 Tools Required	8
7-2 MC-900 SELECTRONIC® Control Operation and Shutdown	9
Section 8: Replacement Parts	11
8-1 Replacement Parts	11
8-2 Replacement Parts Detroit Diesel Modules	11

Section 1: Introduction

1-1 System.

1-1.1 The MURPHYMATIC® Manual Generator Engine Control System, Series MC-900 is designed to meet the requirements of the engine control and shutdown for manual start generator engines.

By combining one of the MC-900 series controls with generator instruments, a complete engine generator control panel can be provided.

1-2 Models.

1-2.1 The Series MC-900 is available in two basic configurations:

1-2.1.1 Model MC-900 for manual start and stop generator sets with four cycle engines which includes the minimum normal shutdowns.

1-2.1.2 Model MC-900-2 for manual start and stop generator sets with two cycle engines which includes the minimum normal shutdowns and an "Overspeed Relay" to operate the air shutoff solenoid for overspeed shutdown.

1-2.2 Both models are available for 12 or 24 volt operation.

1-2.3 Both models include four unlabeled shutdown circuits for additional customer specified shutdowns.

1-2.4 Each model is made up of two parts, a Control/Display module and a Relay module.

1-3 Purpose.

1-3.1 This manual is directed to the installation, maintenance and operating personnel who will be in day to day contact with the MC-900 system.

1-3.2 No manual can cover all aspects of a product. However the basic knowledge gained with this material will allow those personnel to easily adjust to special circumstances.

1-4 Definitions.

1-4.1 Throughout this manual, reference is made to organizations, trade names and trademarks which may not be familiar to the reader. Some of these are:

1-4.1.1 NFPA: National Fire Protection Association.

1-4.1.2 NFPA-70: The National Electrical Code.

1-4.1.3 Several terms used in this manual are registered trademarks of Frank W. Murphy Mfr.

- (a) MURPHYMATIC®: Refers to all Murphy automatic controls.
- (b) SELECTRONIC®: A name that is applied to all electronic controls manufactured by Murphy.
- (c) SWICHGAGE®: A combination indicating gauge and switch.
- (d) TATTLETALE®: A term that refers to a shutdown indicating device or circuit in the control panel.

1-5 How to use this manual.

1-5.1 Section 1, 2, 4, 5, 6 and 7 contain general information that applies to all MC-900 models.

1-5.2 Section 3, Model Identification, is broken into three sub sections. Section 3-1 allows you to chose the model that best fits your requirements and Section 3-2 and 3-3 explain each models features in detail.

Section 2: Specifications

2-1 Enclosure Type.

2-1.1 The MC-900 Series enclosure is designed to be mounted in a standard electrical enclosure for indoor use.

2-1.2 The MC-900 Series shares the same enclosure as the A-900 automatic start controller so they can be used interchangeably in a generator control panel.

2-2 Power Requirements.

2-2.1 The engine controls, shutdown circuits and shut-down indicators are powered from the engine starting battery. The MC-900 series is available in either 12 or 24 volt, negative ground.

2-2.2 The MC-900 is fused for 3 amp. maximum current.

2-3 Input Ratings.

2-3.1 All input switches should be dry contact type, maximum current is 2 ma, 8 VDC or less.

2-3.2 Frequency signal for the speed sensing circuit requires a minimum input of 2 volts RMS from a magnetic pickup (preferred) or from the tachometer terminal of the battery charging alternator.

2-3.2.1 Frequency range of the speed sensing circuit is 300 Hz to 10,000 Hz.

2-4 Output Ratings.

2-4.1 The MC-900 Control / Display Module has outputs for remote indication of shutdowns. These outputs are transistors that close to the negative supply (sink) and are rated at 1 amp, 30 VDC maximum.

2-4.2 The Control / Display Module also has an output for an auxiliary starter contactor which is rated 1 amp, 30 VDC maximum. This is a transistor that closes to the positive supply (source).

2-4.3 The Relay Module includes 3 engine control relays with contact ratings of 7 amp, 30 VDC inductive. These powered contacts must be supplied from an 8 amp. fuse or circuit breaker (customer supplied).

2-5 Field Wiring Connections.

2-5.1 All field wiring connections are barrier terminal blocks, UL rated for 15 amp, 300 volt.

2-6 Operating Temperature.

2-6.1 The operating temperature range of the MC-900 is -4°F to 158°F / -20°C to 70°C.

Section 3: Model Identification

3-1 Model Numbers.

3-1.1 MC-900-12 and MC-900-24: These models are designed for a manual start four cycle engine driven generator, and include the minimum shutdown points normally supplied on such installations. The suffix numbers -12 and -24 indicate the engine starting battery voltage.

3-1.2 MC-900-2-12 and MC-900-2-24: These models are designed for a manual start two cycle engine driven generator, and include the minimum shutdown points normally supplied on such installations. The suffix numbers -12 and -24 indicate the engine starting battery voltage.

3-1.2.1 The MC-900-2 series control includes an "Overspeed Relay" to trip the air shut-off solenoid on overspeed of a two cycle engine.

3-2 MC-900.

3-2.1 Control / Display Module. The Control / Display Module, figure 3-2.1, includes the control and test switches, the solid state logic elements and shutdown TATTLETALE® lights that make up the generator engine control for a four cycle engine.

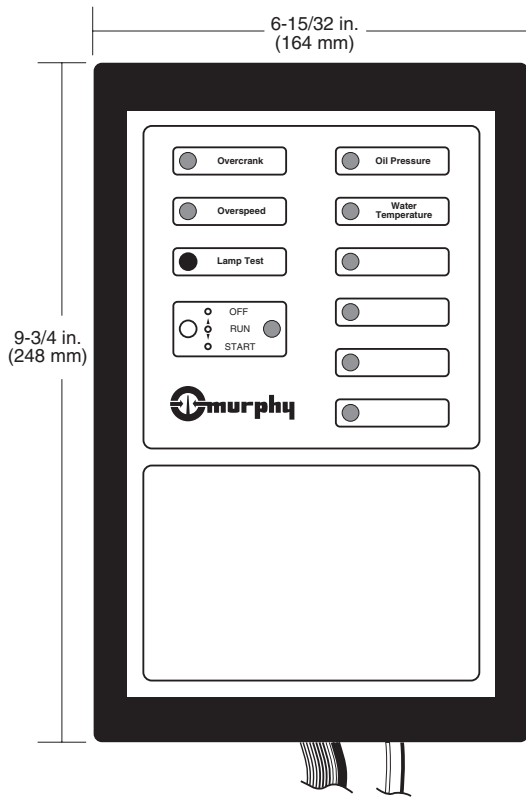

Figure 3-2.1

3-2.1.1 Mode Selector Switch, OFF-RUN-START:

- OFF; turns off the control system and resets any shutdown circuits.
- RUN; turns on the engine controls and shutdown circuits. System is on, waiting for the engine to start. Switch returns to run position from START after starting engine.
- START; turns on the engine start circuit. A start signal is applied to the auxiliary start solenoid and the engine starter engages. Releasing the start switch disconnects cranking.

3-2.1.2 Lamp Test Pushbutton: Tests the lights on the MC-900 module when the Mode Selector Switch is in the RUN position.

3-2.1.3 The MC-900 SELECTRONIC® Control Module includes the following engine control features:

- Overcrank circuit; will stop manual cranking and indicate overcrank if start switch remains closed longer than the overcrank time setting. The crank time is selectable for 10, 15, 20, 25 or 30 seconds before shutdown.
- Shutdown Time Delay Bypass; this delay prevents the oil pressure and water temperature shutdown circuits from operating for 30 seconds after the engine starts as detected by the Mode Selector Switch returning to RUN

position. This same delay can also lock out all other shutdown circuits except Overspeed and Overcrank. The user may select which circuits are locked out by the time delay bypass.

(c) Overspeed Speed Switch;

- Provides a signal to the overspeed shutdown circuit if the engine exceeds the preset speed. The factory setting is approximately 3894 Hz, or 1980 RPM on an engine with 118 teeth on the flywheel ring gear. The adjustment range is 300 Hz to 10,000 Hz.
- A push to test switch is provided to allow testing of the overspeed circuit without overspeeding the engine. When switch is depressed, the set point of the speed switch is lowered approximately 10%.
- The push to test switch can also be used to set the overspeed switch at approximately 110% of running speed. Hold the switch depressed while adjusting the setting until the overspeed trips. When switch is released, the set point will be 10% above normal running speed. This is the method used to make the factory setting. With engine speed at 1800 RPM or 3540 Hz.

3-2.1.4 Eight (8) First-out Shutdown Circuits; provide first-out indication of cause of shutdown. These circuits deactivate the fuel relay and lockout the MC-900 until reset. Shutdown circuits are activated by the Mode Selector Switch and or Shutdown Time Delay Bypass. Eight (8) Red Shutdown Indicating Lights are provided.

- Overcrank; tripped by the overcrank timing circuit which times as long as the START switch is closed.
- Overspeed; tripped by overspeed switch when engine exceeds a preset speed.
- Oil Pressure; tripped by the oil pressure SWITCHGAGE® if pressure drops below preset point while the engine is running.
- Water Temperature; tripped by the water temperature SWITCHGAGE® if engine coolant temperature exceeds the switch setting.
- Spare Shutdowns; tripped by an external switch. These circuits are provided for additional shutdowns that may be recommended by the engine supplier or required by the user.

3-2.2 Relay Module. The Relay Module, figure 3-2.2, includes all of the control and shutdown relays that are required to make up the generator engine control. Relays are available for operation on either 12 or 24 volt battery systems. Two (2) relays are included for:

3-2.2.1 Fuel Relay; this relay provides two outputs, one to energize the engine fuel solenoid and a separate circuit to energize the battery charging alternator field.

3-2.2.2 Shutdown Relay; this relay is operated by the shutdown circuits of the Control / Display Module and provides an output that can be used to trip the generator circuit breaker on an emergency shutdown.

3-2.3 Status Signal; The relay module also includes an output that can be used with external circuits for signaling or control functions.

3-2.3.1 The Run signal at terminal 17 is on (closed to negative) as long as the Mode Selector Switch is in either Run

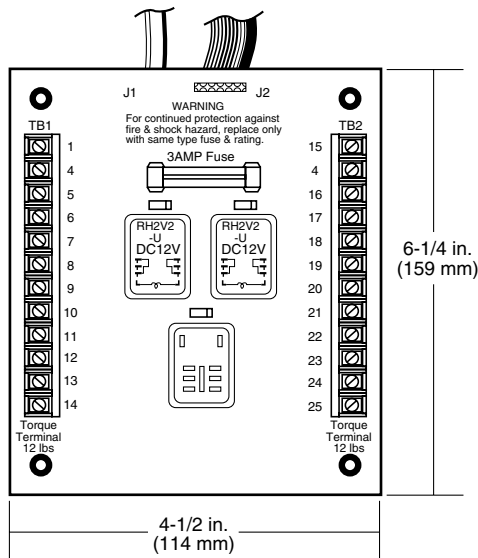

Figure 3-2.2

or Start and no shutdown TATTLETALE® circuit is latched on. This can be used to signal that the generator engine is ready to start or is running.

3-3 MC-900-2.

3-3.1 Control / Display Module. The Control / Display Module, figure 3-2.1, is also used as on the Model MC-900-2.

3-3.2 Relay Module. The Relay Module, figure 3-3.2, includes all of the control and shutdown relays that are required to make up the generator engine control. Relays are available for operation on either 12 or 24 volt battery systems.

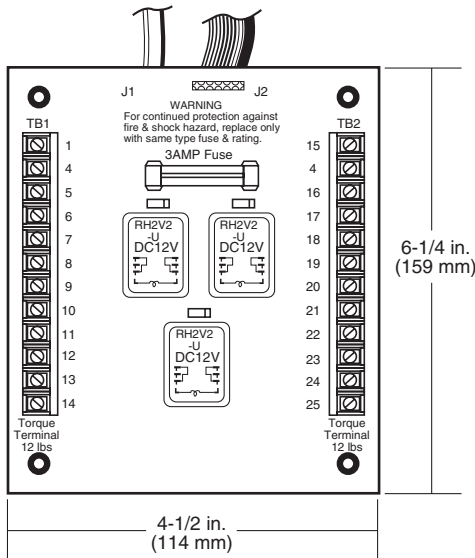

Figure 3-3.2

Three (3) relays are included for:

3-3.2.1 Fuel Relay; this relay provides two outputs, one to energize the engine fuel solenoid and a separate circuit to energize the battery charging alternator field.

3-3.2.2 Shutdown Relay; this relay is operated by the shutdown circuits of the Control / Display Module and provides an output that can be used to trip the generator circuit breaker on an emergency shutdown.

3-3.2.3 Overspeed Relay; operates only on an Overspeed

shutdown. This relay provides an output to trip an air shut off solenoid to close the air damper on a two cycle engine.

3-2.3 Status Signal; The relay module also includes an output that can be used with external circuits for signaling or control functions.

3-2.3.1 The Run signal at terminal 17 is on (closed to negative) as long as the Mode Selector Switch is in either Run or Start and no shutdown TATTLETALE® circuit is latched on. This can be used to signal that the generator engine is ready to start or is running.

Section 4: Installation

4-1 Location.

4-1.1 The MC-900 series is designed to mount in a MURPHYMATIC® Generator Control panel with the Control / Display module on the front panel and the Relay module on the inside bottom surface. Other types of installation is possible as long as the relationship of the two modules are maintained.

4-1.2 Clearance for Installation and Service; The modules must be accessible for wiring to the terminal blocks and adjustment of the user controls on the back of the Control / Display module. Figure 4-1.2 shows the mounting dimensions and the minimum clearances recommended for installation.

4-1.3 Wiring Terminals; Terminal blocks are provided on both sides of the Control / Display enclosure and the Relay Module. Torque all terminal screws to 12 inch pound maximum.

4-2 Wiring.

4-2.1 After the MC-900 has been located and installed, the wiring connections can be made. This work should be done with all electrical power disconnected from the engine. **BE SURE THAT THE BATTERY IS DISCONNECTED.**

4-2.2 All electrical installation work should be done in accordance with the National Electrical Code, NFPA-70, and all applicable local codes.

4-2.3 In general, the following connections will be made:

- Battery positive and negative.
- Engine run device, such as a fuel shutoff solenoid.
- Engine speed sensor, such as a magnetic pickup or the tachometer output of a battery charging alternator.
- Engine starter circuit; an auxiliary starter solenoid is required to handle most starter solenoid requirements.
- Shutdown sensing switches as required.

4-2.3.1 The complete wiring of a Model MC-900 control is shown in figure 4-2.3.1. Provision is made in the MC-900 series to operate remote lights for all of the shutdown circuits however these circuits do not have to be wired for the MC-900 to function.

4-2.3.2 Figure 4-2.3.2 is for wiring of the MC-900-2 control. The same provisions as for the MC-900 are made.

4-2.3.3 Wire Termination; the terminal blocks that are supplied requires that all wires be terminated with #6 stud size forked spade solderless wire connectors or stripped and inserted under the captive terminal plates. Torque all terminal screws to 12 inch pound maximum.

4-2.3.4 All inductive loads (relays-solenoids-coils-etc.) that are connected to the MC-900 must have reverse diodes wired

Figure 4-1.2: Dimensions

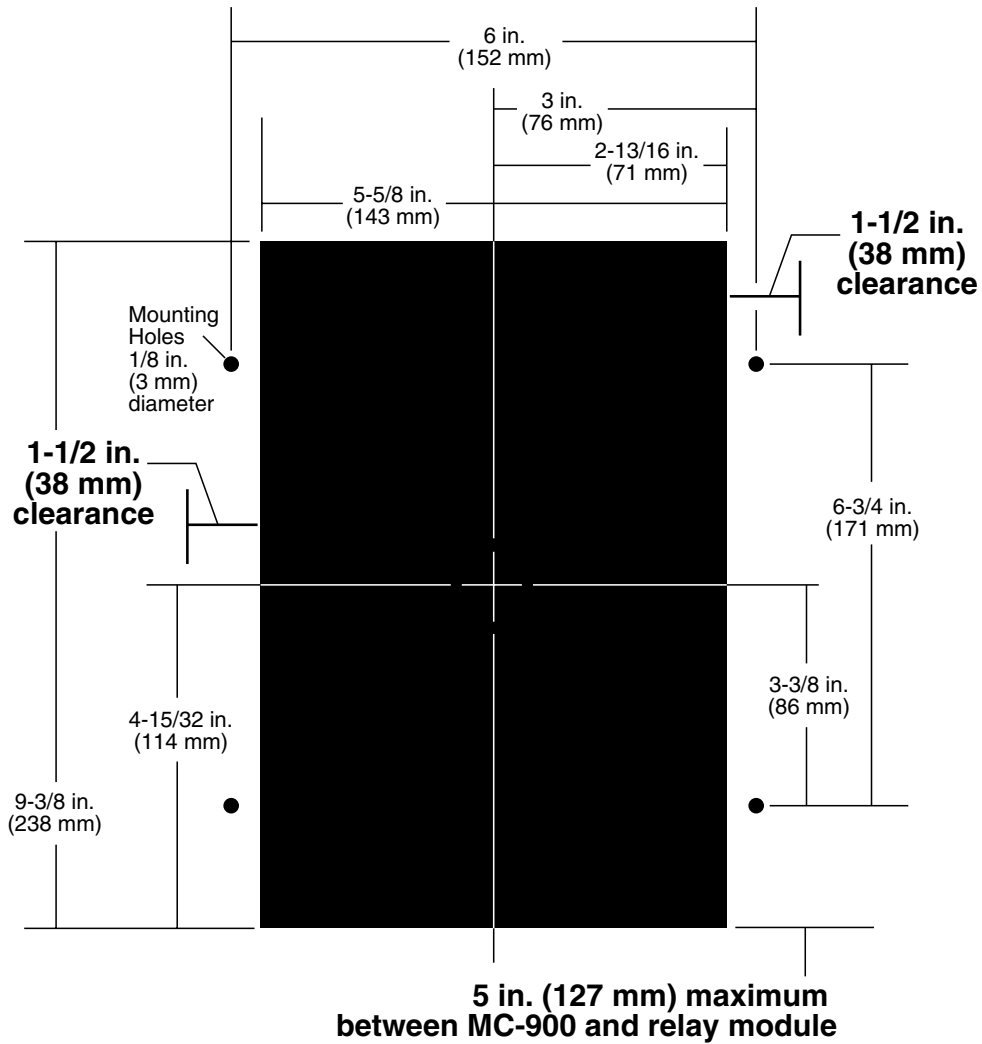

NOTE:
Clearance required for wire run.

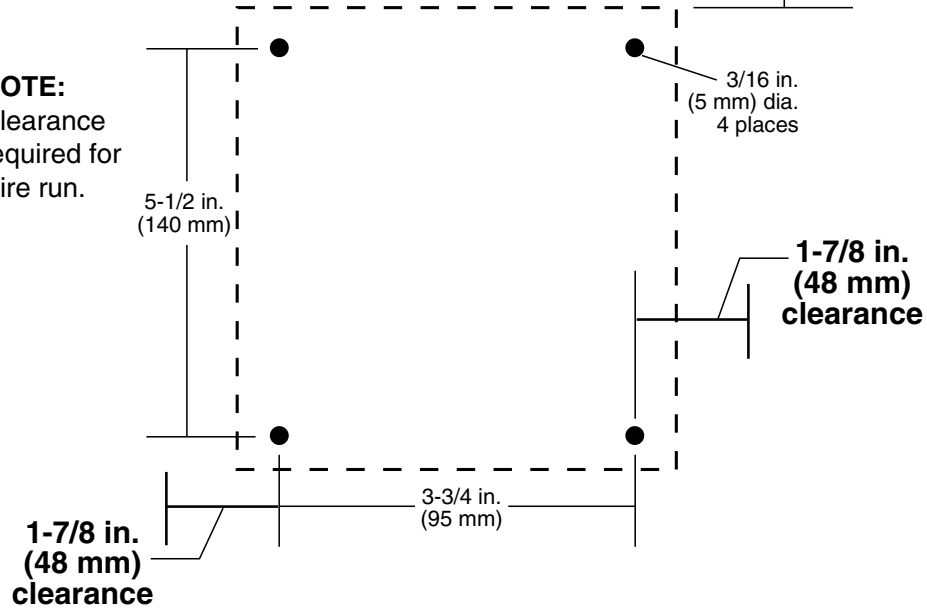

Figure 4-2.3.1: MC-900 wiring

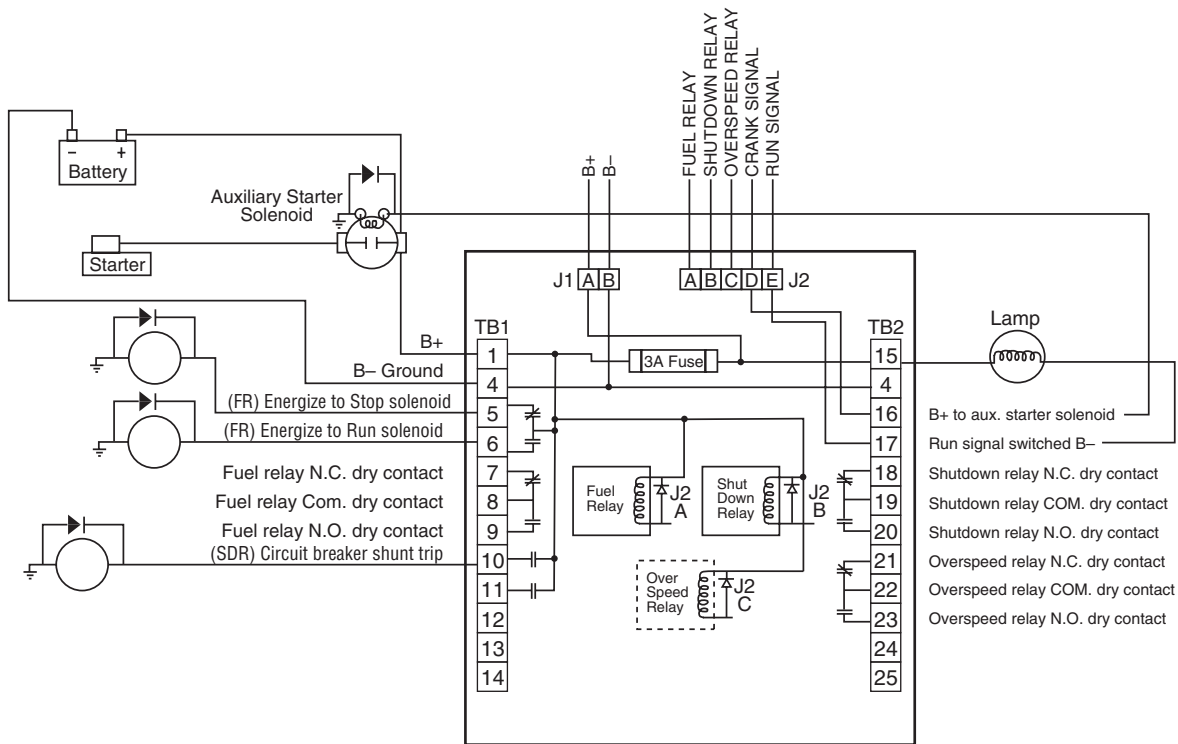
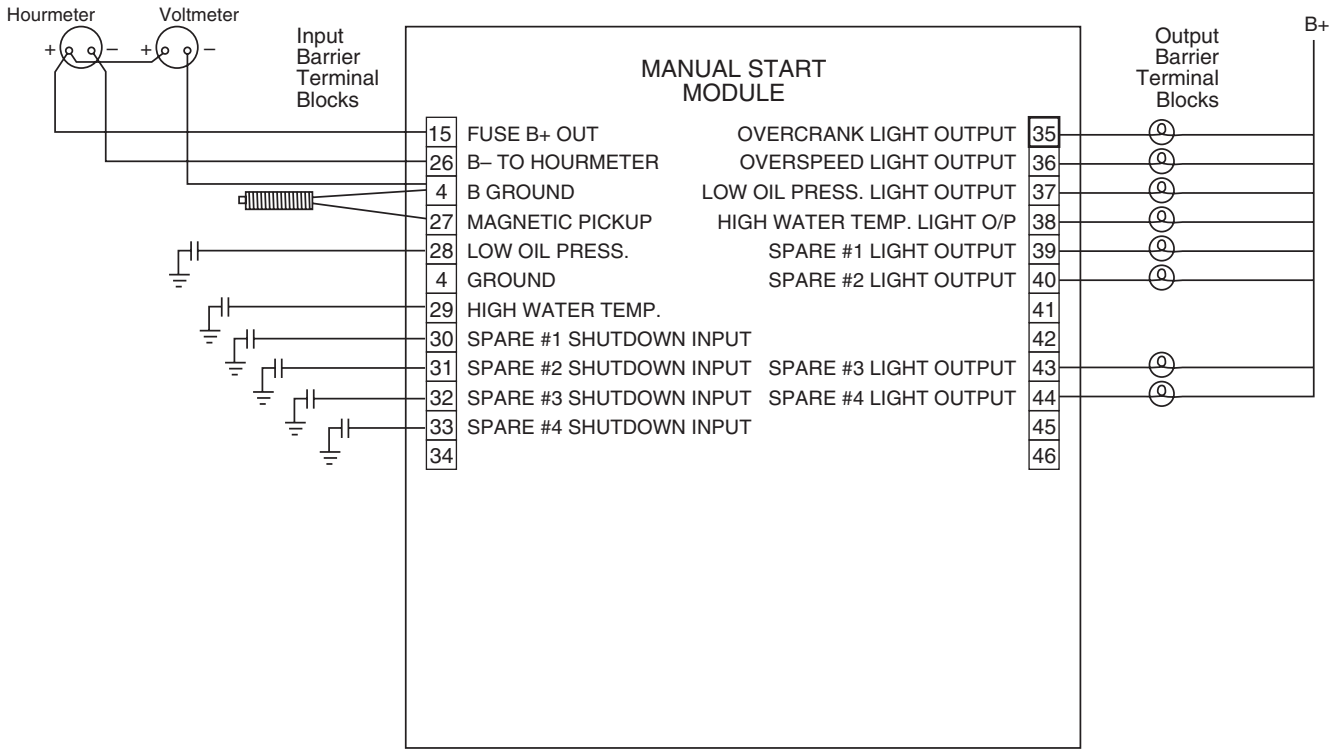
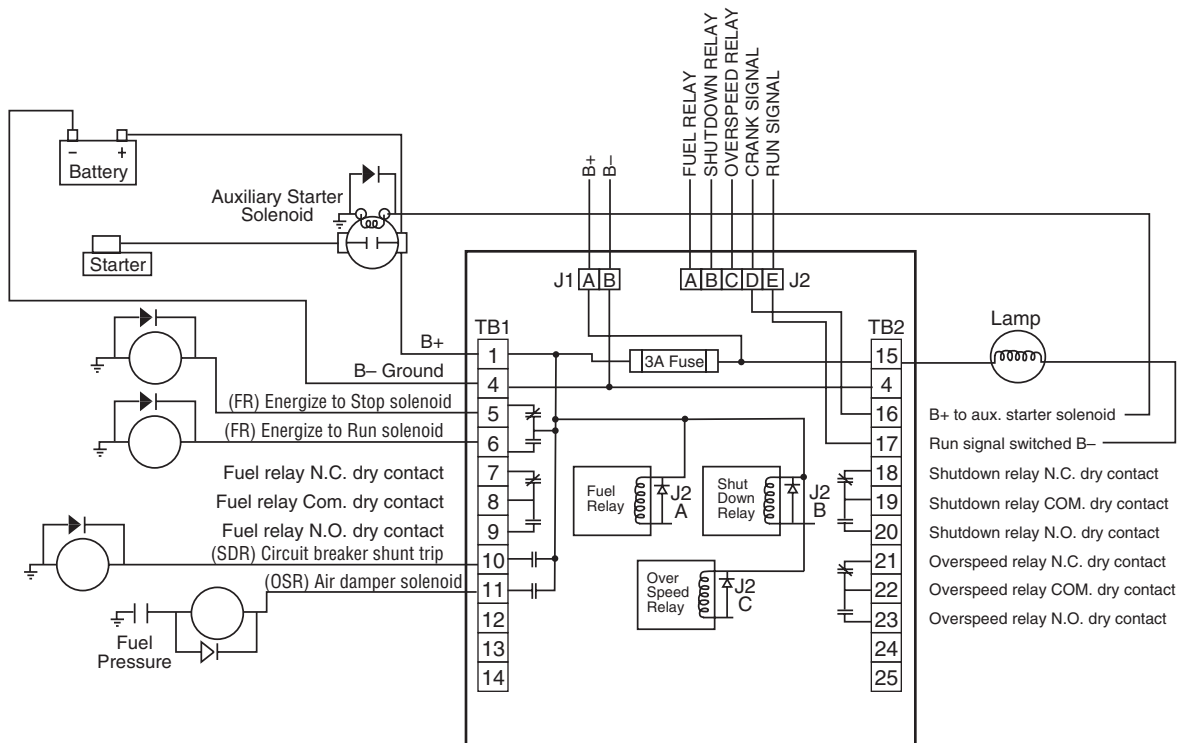
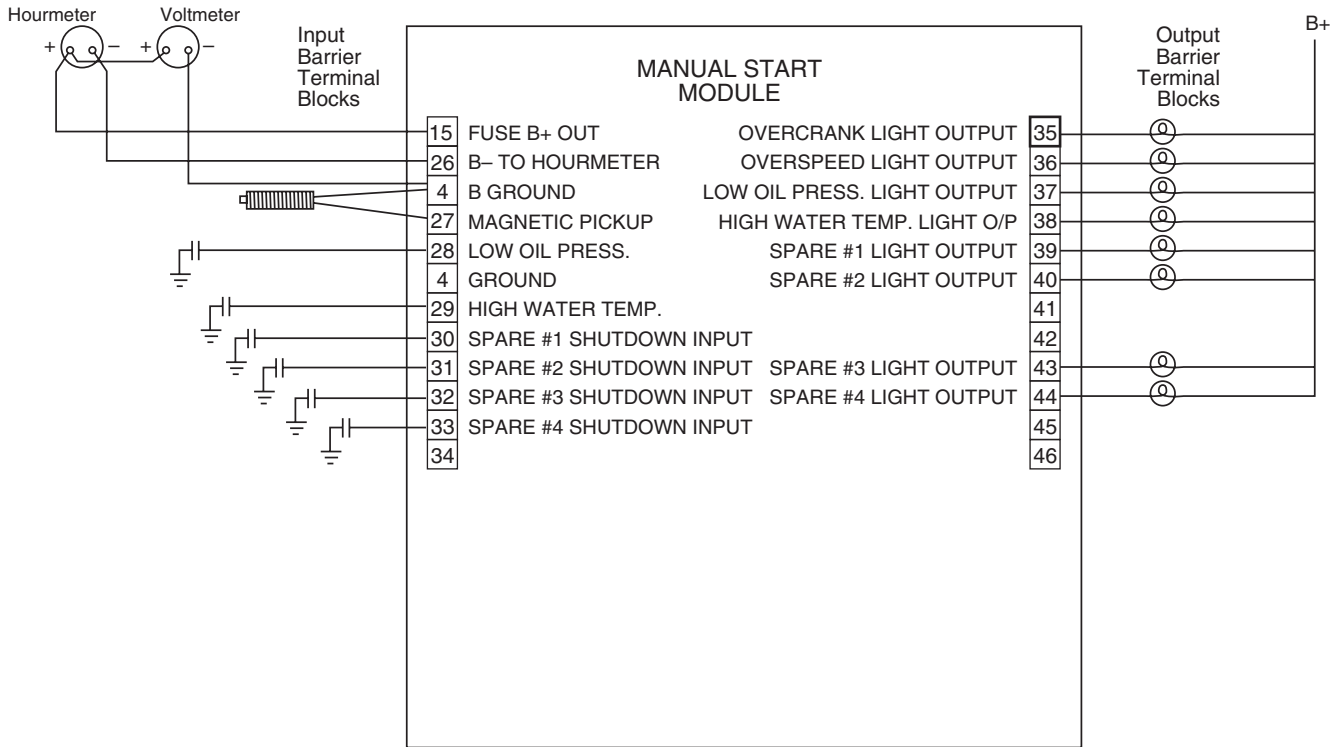

Figure 4-2.3.2: MC-900-2 wiring



across the coil to suppress reverse voltage that is generated whenever the inductive load is de-energized. This will protect the electronic components in the MC-900 and should prevent operating malfunction due to noise. The “rule of thumb” for sizing the reverse diode is to use one with a PIV (Peak Inverse Voltage) rating equal to the operating voltage or at least 100 volts and a current rating that is equal to or greater than the forward current that the coil draws to operate. For example, a relay less than 1 A, use a 1 A diode since they are readily available. The wiring shown in figures 4-2.3.1 and 4-2.3.2 have examples of the places that a reverse diode is required.

4-3 Overspeed Switch.

4-3.1 A magnetic pickup is recommended to supply the speed signal for the MC-900 series overspeed switch. This pickup will be mounted in the flywheel housing in line with the ring gear on the flywheel and wired to the MC-900 using either a twisted pair or a shielded cable to reduce the possibility of electrical noise pickup in the wiring.

4-3.2 The tachometer terminal, of the battery charging alternator, may be used for the speed signal but a broken drive belt will disable this source and some alternators have electrical noise which will cause the speed switches to operate at speeds well below the desired RPM.

4-4 Pre-operational Check-out.

4-4.1 After installation is complete, it is necessary to make some adjustments to the MC-900 SELECTRONIC® Control before the system is operational. All shutdown circuits also should be tested. Table 4-4.1 lists the standard factory setting of the adjustable functions on the MC-900 series control. To determine if the frequency of the speed switch must be changed, calculate the required setting using the following formulas:

$$\text{Set point frequency in HZ} = \frac{\text{No. of Gear Teeth} \times \text{RPM set points}}{60}$$

OR

$$\text{Set point frequency in HZ} = \frac{\text{Pulley ratio} \times \text{No. of Alternator Poles} \times \text{RPM set points}}{60}$$

Refer to Table 4-4.1 to determine if the speed switch setting is below the factory setting listed. If required frequency will be higher than the standard, increase the setting before proceeding. Turn the Overspeed Set pot clockwise to increase setting. The adjustment is a 20 turn control without stops at either end.

Table 4-4.1

Function	Standard Setting	Adjustment Range	Adjustment Type
Crank Time	15 seconds	10, 15, 20, 25 and 30 Seconds	Switch
Overspeed	3894 Hz	300 to 10 KHz	Pot. 500 Hz per turn CW to increase
Lockout for Start	SW1, SW2 Closed SW3, 4, 5, 6 Open	—	Switch

4-4.1.1 Be sure to have a fully charged battery to do these tests. Low battery voltage can cause improper results during the tests.

4-4.1.2 All of the adjustments and controls shown in Table 4-4.1 are located on the rear of the control/display module. See Figure 4-4.1.2. Each light and switch is labeled for ease of identification. The LED’s are supplied as an aid in installation and troubleshooting of the MC-900.

Figure 4-4.1.2

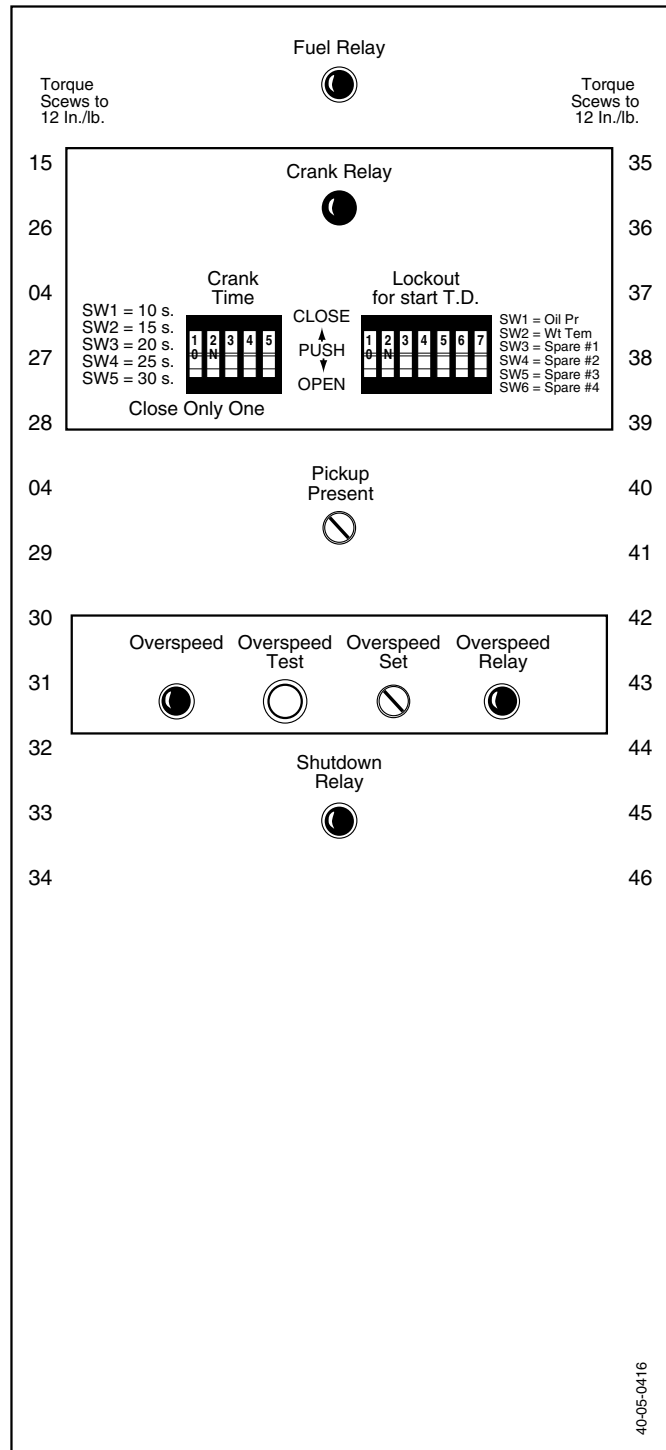

4-4.2 Start and Stop Engine; to test the start and stop function, proceed as follows:

- Double check all wiring to be sure it is connected.
- Turn Mode Selector switch to the START position.
- Engine should crank and start. Return switch to RUN position.
- When engine has come up to speed and governor has

been adjusted for proper running speed, turn Mode Selector switch OFF.

- (e) All lights on the back of the MC-900 should go off and the engine stop. If engine does not stop, check run solenoid to be sure it has returned to the stop position.

4-4.3 Overspeed Switch Setting; To set the speed switch, proceed as follows:

- (a) Turn Mode Selector switch to the START position.
- (b) Engine should crank and start. Return switch to RUN position.
- (c) With engine running, adjust governor to bring engine speed to normal RPM.
- (d) Depress and hold the Overspeed Test pushbutton.
- (e) Slowly turn the Overspeed Set adjustment counter-clockwise until the "Overspeed" and "Overspeed Relay" lights on the MC-900 come on and the engine shuts down.
- (f) Release pushbutton; check "Overspeed" light on front panel to be sure it is on.
- (g) Turn Mode Selector switch OFF to reset shutdown circuits.
- (h) Restart engine, when engine starts, increase governor speed setting slowly until engine shuts down on overspeed. This should occur about 10% above governor speed.
- (i) Turn Mode Selector switch OFF.

4-4.4 Overcrank setting; to test the time before system shuts down on overcrank;

- (a) Disconnect the run solenoid wire from terminal 6 of the Relay Module.
- (b) Check time set on the "Crank Time" switch on MC-900 back panel. It is factory set at 15.
- (c) Turn Mode Selector switch to START.
 1. Engine will crank for 15 seconds.
 2. After 15 seconds the "Overcrank" light on the MC-900 will come on and engine will stop cranking.
- (d) Turn Mode Selector switch OFF.
- (e) Reconnect the run solenoid wire at terminal 6 of the Relay Module.

4-4.5 Oil Pressure; to test oil pressure shutdown circuit:

- (a) Turn Mode Selector switch to START. When engine starts, wait 30 seconds then,
- (b) Use a jumper wire and short from terminal 28 to 4.
- (c) "Oil Pressure" light will come on and engine will stop.
- (d) Turn Mode Selector switch OFF.

4-4.6 Water Temperature; to test the water temperature shutdown circuit:

- (a) Turn Mode Selector switch to START. When engine starts, wait 30 seconds then,
- (b) Use a jumper wire and short from terminal 29 to 4.
- (c) "Water Temperature" light will come on and engine will stop.
- (d) Turn Mode Selector switch OFF.

4-4.7 All other Shutdowns; all other shutdowns would be tested in the same manner.

- (a) For shutdown circuits which are locked out by the Shutdown Time Delay Bypass, you must wait 30 seconds before running the test.
- (b) Circuits that are not locked out may be tested as soon as the engine is running or may be tested without starting

the engine by turning the Mode Selector switch to RUN position.

- (c) To test other shutdowns, a jumper wire can be used to short the input terminal for that circuit, to ground, terminal 4.

Section 5: Operation

5-1 Operator Controls.

5-1.1 Mode Selector Switch; allows the operator to start the engine (START), run the engine (RUN), or stop the engine (OFF).

5-1.2 The OFF position on the mode selector also provides a reset function for the shutdown circuits. If the engine is shut down by the automatic control, the operator must turn selector off and back on to reactivate the system.

5-1.3 Push to Test Lamps; this pushbutton tests the shutdown indicator lights.

5-2 Operating Modes.

5-2.1 The MC-900 Generator Engine Control has only one operating mode: manual start and automatic shutdown on a sensed failure of one of the monitored inputs.

5-2.2 Manual electric start is provided for operation of the generator set.

5-2.2.1 To initiate Manual start, place the Mode Selector switch in the START position. This provides a start signal to the engine starter.

5-2.2.2 When engine starts, return selector switch to RUN. This removes start signal and the engine will run.

5-2.3 OFF or Not Operating; to prevent operation of the engine, turn selector switch OFF.

5-2.3.1 The OFF position is used as a reset for any automatic shutdown that occurs.

Section 6: Routine Maintenance and Operational Tests

6-1 Routine Maintenance.

6-1.1 Due to the design and types of components used, very little maintenance is required to the MC-900 Control.

6-1.2 Visual inspection of the internal wiring of the control panel, along with checking wire connections for tightness, should be done on a semiannual schedule for stand-by systems or quarterly for prime power. Check wire bundles for chafing and wear to the insulation of the wires where they contact the panel or engine.

6-1.4 Shutdown Circuits should be tested on a monthly basis for prime power and quarterly for stand-by sets. The same tests run during pre-operation check out, Section 4-4, should be included.

6-2 Operational Tests.

6-2.1 No special operational tests are required. The routine operational tests for the generator set will exercise the control.

Section 7: Troubleshooting and Repair

7-1 Tools Required.

7-1.1 Some of the tools necessary for troubleshooting are built into the MC-900 Series controls.

7-1.1.1 By observing the lights on the front and rear of the control panel, clues to a problem and the possible source can be seen.

7-1.2 Other tools which may be required are:

7-1.2.1 AC/DC Voltmeter for taking voltage readings and an Ohmmeter for testing resistance of wires and connections.

7-1.2.2 Jumper wires with alligator clips to bypass or simulate circuit closures.

DO NOT USE THESE JUMPER WIRES TO CHECK IF VOLTAGE IS PRESENT AT A TERMINAL BY DRAWING AN ARC TO GROUND. THIS WILL DAMAGE OR DESTROY EQUIPMENT IN THE MC-900 CONTROL PANEL.

7-2 MC-900 SELECTRONIC® Control Operation and Shutdown.

7-2.1 The first step in troubleshooting any equipment is to understand its normal operation. Table 7-2.1 contains normal voltage readings taken at the terminals of the MC-900 with all equipment shown on the standard drawing, connected.

- (a) All voltage readings are DC, except at terminal 27, and were taken with the negative lead of the meter connected to ground at terminal 4. Voltage reading at terminal 27 was taken with negative lead grounded and the meter on AC scale.
- (b) The battery voltage, at the time readings were recorded, was 13.8V and 27.6V. All readings will vary depending on battery voltage, equipment supplied in the panel and external devices connected to the MC-900 control. See notes to the table for examples.
- (c) Voltages less than battery also may vary due to tolerances of the electronic components in the MC-900. Minor variations, 1 or 2 volts, normally will have no effect on the MC-900 operation.
- (d) The AC voltage at terminal 27 must be a minimum of 2 VAC to drive the speed sensing circuits of the MC-900.

7-2.2 With power applied and the Mode Selector switch in OFF, the following occurs when the switch is moved to the START position.

7-2.2.1 The fuel relay is energized, which opens the circuits at terminal 5 and 7, and closes the circuits at terminal 6 and 9. This applies battery power to the run solenoid and to the exciter terminal of the alternator (if used).

7-2.2.2 At the same time, the crank relay driver provides battery voltage at terminal 16 to the auxiliary starter solenoid. This output is controlled by the Mode Selector switch and the Overcrank timer. The output will remain on until the Mode Selector switch is returned to RUN or the Overcrank time expires.

7-2.2.3 If the engine does not start during the Overcrank time, the overcrank shutdown circuit trips and removes the output to the starter solenoid. The Mode Selector switch must be turned OFF to reset the shutdown circuit.

7-2.2.4 When the engine starts and the Mode Selector switch is returned to the RUN position,

- (a) Cranking is terminated.
- (b) A time delay starts timing during which the oil pressure and water temperature shutdown circuits are locked out.
- (c) The overcrank timer is reset to zero.
- (d) The overspeed shutdown circuit is activated.

7-2.2.5 An engine run signal closes to ground at terminal 17 when the Mode Selector switch is in the RUN position and the engine is not shutdown by the MC-900 shutdown circuits.

7-2.3 With the Mode Selector switch in the RUN position, six of the eight shutdown TATTLETALE® circuits are activated and will operate anytime a switch closes from ground to their inputs.

Circuit	Input	Output
(a) Oil Pressure	Terminal 28	Terminal 37
(b) Water Temp	Terminal 29	Terminal 38
(c) Overspeed*	Int. Speed Switch	Terminal 36
(d) Overcrank**	Int. Circuit	Terminal 35
(e) Spare Shutdown #1	Terminal 30	Terminal 39
(f) Spare Shutdown #2	Terminal 31	Terminal 40
(g) Spare Shutdown #3	Terminal 32	Terminal 43
(h) Spare Shutdown #4	Terminal 30	Terminal 44

*Engine must be running to operate speed switch

**Circuit operates only while cranking

7-2.3.1 Each circuit has a indicating light and a transistor output that closes to ground to operate an individual remote indicating light.

7-2.3.2 When any of the eight shutdown functions trip, the shutdown relay K-2, pulls in and applies battery power to terminal 10. At the same time, the fuel relay, K-1 drops out and if the shutdown was due to overspeed, the overspeed relay, K-3 pulls in to signal an air shut off solenoid, terminal 11 to close.

7-2.3.3 The eight shutdown circuits, paragraph 7-2.3, are first out latching type TATTLETALES®. That is, only one of the eight may trip at one time and it must be reset before the MC-900 will operate again.

7-2.3.4 If one of the TATTLETALE® circuits trip, the following occurs to shutdown the engine and generator.

- (a) The TATTLETALE® light for that function turns on.
- (b) Shutdown relay K-2 is energized, closing its contacts at terminal 10. These contacts can be wired to a shunt trip solenoid in the generator circuit breaker if required.
- (c) The fuel relay drops out, removing battery voltage from the run solenoid, terminal 6. The circuit at terminal 5 will close to reconnect the battery positive to this terminal.
- (d) The run signal, terminal 17 turns off.
- (e) If the shutdown is due to overspeed, the overspeed relay operates and applies battery positive to terminal 11 to close an air shutoff solenoid if the engine is so equipped.

7-2.3.5 The dry contacts of relay K-1, at terminals 7, 8 and 9; relay K-2, at terminals 18, 19 and 20; and relay K-3, at terminals 20, 21 and 22; change state when the relays operate.

7-2.3.6 To reset the circuits, the Mode Selector switch must be turned OFF.

7-2.4 Normally, the engine will run until the Mode Selector switch is turned OFF.

7-2.4.1 When this happens, the following occurs to stop the engine;

- (a) The fuel relay drops out, removing battery voltage from the run solenoid. The circuit at terminal 5 will close to reconnect the battery positive to this terminal.
- (b) The run signal, terminal 17 turns off.
- (c) The TATTLETALE® circuits are locked out as soon as the switch is turned OFF. This prevents any TATTLETALE® from tripping while the engine coasts to a stop.

Table 7-2.1

Terminal Number	Mode Selector OFF		Mode Selector START Cranking		Mode Selector RUN Running		Mode Selector RUN Shutdown	
	Input 13.8	Voltage 27.6	Input 13.8	Voltage 27.6	Input 13.8	Voltage 27.6	Input 13.8	Voltage 27.6
1	13.8	27.6	13.8	27.6	13.8	27.6	13.8	27.6
4	0	0	0	0	0	0	0	0
5	13.8	27.6	0	0	0	0	13.8	27.6
6	0	0	13.8	27.6	13.8	27.6	0	0
7	0	0	0	0	0	0	0	0
8	0	0	0	0	0	0	0	0
9	0	0	0	0	0	0	0	0
10	0	0	0	0	0	0	13.8	27.6
11	0	0	0	0	0	0	0	0
12	0	0	0	0	0	0	0	0
13	0	0	0	0	0	0	0	0
14	0	0	0	0	0	0	0	0
15	13.8	27.6	13.8	27.6	13.8	27.6	13.8	27.6
16	0	0	13.8	27.6	0	0	0	0
17	0	0	0	0	0	0	0	0
18	0	0	0	0	0	0	0	0
19	0	0	0	0	0	0	0	0
20	0	0	0	0	0	0	0	0
21	0	0	0	0	0	0	0	0
22	0	0	0	0	0	0	0	0
23	0	0	0	0	0	0	0	0
24	0	0	0	0	0	0	0	0
25	0	0	0	0	0	0	0	0
26	13.8	27.6	0	0	0	0	13.8	27.6
27 (1)	0	0	4	4	4	4	0	0
28 (2)	0	0	0	0	7.5	7.5	0	0
29	0	0	7.5	7.5	7.5	7.5	7.5	7.5
30	0	0	7.5	7.5	7.5	7.5	7.5	7.5
31	0	0	7.5	7.5	7.5	7.5	7.5	7.5
32	0	0	7.5	7.5	7.5	7.5	7.5	7.5
33	0	0	7.5	7.5	7.5	7.5	7.5	7.5
34	0	0	0	0	0	0	0	0
35	13.8	27.6	13.8	27.6	13.8	27.6	13.8	27.6
36	13.8	27.6	13.8	27.6	13.8	27.6	13.8	27.6
37 (2)	13.8	27.6	13.8	27.6	13.8	27.6	0	0
38	13.8	27.6	13.8	27.6	13.8	27.6	13.8	27.6
39	13.8	27.6	13.8	27.6	13.8	27.6	13.8	27.6
40	13.8	27.6	13.8	27.6	13.8	27.6	13.8	27.6
41	0	0	0	0	0	0	0	0
42	0	0	0	0	0	0	0	0
43	13.8	27.6	13.8	27.6	13.8	27.6	13.8	27.6
44	13.8	27.6	13.8	27.6	13.8	27.6	13.8	27.6
45	0	0	0	0	0	0	0	0
46	0	0	0	0	0	0	0	0

NOTES

Note 1: AC voltage measured on AC scale of volt-ohmmeter.

Note 2: Low Oil Pressure shutdown circuit.

Oil pressure was the cause of shutdown on column 4.

Section 8: Replacement Parts

8-1 Replacement Parts

8-1.1 Table 8-1 covers all of the replaceable components of the MC-900 Series Generator Engine Controls. The part numbers shown are Frank W. Murphy Mfr. part numbers and may not appear on the individual parts.

8-1.2 Each complete control is made up of a Control / Display Module, a Relay Module and a number of Relays.

8-1.3 There are no field replaceable parts in the Control / Display Module, the complete module must be replaced if it fails. All relays are individually replaceable in the Relay Module but the module must be replaced if a failure of the circuit board occurs.

8-2 Replacement Parts Waukesha Modules

8-2.1 Table 8-2 part numbers are Murphy part numbers for MC-900 controls manufactured for Waukesha Corporation. These OEM parts are available only to Waukesha and their distributors.

8-2.2 The MC-900 parts are the same as the Murphy MC-900 series that has been covered through out this manual.

Table 8-1

Model Number	Part Number	Control / Display	Relay Module	Relay Part	Relay Qty. Module
MC-900-12	40-70-0130	40-00-0023	40-00-0091	00-00-2952	2
MC-900-24	40-70-0177	40-00-0023	40-00-0091	00-00-2953	2
MC-900-2-24	40-70-0173	40-00-0023	40-00-0091	00-00-2953	3

Table 8-2

Model Number	Part Number	Control / Display	Relay Module	Relay Part	Relay Qty. Module
MC-900-2-24 Waukesha	40-35-0047	40-00-0223	40-00-0224	00-00-2953	2



FW Murphy
P.O. Box 470248
Tulsa, Oklahoma 74147 USA
+1 918 317 4100
fax +1 918 317 4266
e-mail sales@fwmurphy.com
www.fwmurphy.com

CONTROL SYSTEMS & SERVICES DIVISION

P.O. Box 1819; Rosenberg, Texas 77471; USA
+1 281 633 4500 fax +1 281 633 4588
e-mail sales@fwmurphy.com

MURPHY DE MEXICO, S.A. DE C.V.

Blvd. Antonio Rocha Cordero 300, Fracción del Aguaje
San Luis Potosí, S.L.P.; México 78384
+52 444 8206264 fax +52 444 8206336
Villahermosa Office +52 993 3162117
e-mail ventas@murphymex.com.mx
www.murphymex.com.mx

FRANK W. MURPHY, LTD.

Church Rd.; Laverstock, Salisbury SP1 1QZ; U.K.
+44 1722 410055 fax +44 1722 410088
e-mail sales@fwmurphy.co.uk
www.fwmurphy.co.uk

MURPHY SWITCH OF CALIFORNIA

41343 12th Street West
Palmdale, California 93551-1442; USA
+1 661 272 4700 fax +1 661 947 7570
e-mail sales@murphyswitch.com
www.murcal.com

MACQUARRIE CORPORATION

1620 Hume Highway
Campbellfield, Vic 3061; Australia
+61 3 9358 5555 fax +61 3 9358 5558
e-mail murphy@macquarrie.com.au



In order to consistently bring you the highest quality, full featured products, we reserve the right to change our specifications and designs at any time.

Printed in U.S.A. 1291185

Free Manuals Download Website

<http://myh66.com>

<http://usermanuals.us>

<http://www.somanuals.com>

<http://www.4manuals.cc>

<http://www.manual-lib.com>

<http://www.404manual.com>

<http://www.luxmanual.com>

<http://aubethermostatmanual.com>

Golf course search by state

<http://golfingnear.com>

Email search by domain

<http://emailbydomain.com>

Auto manuals search

<http://auto.somanuals.com>

TV manuals search

<http://tv.somanuals.com>