

Installation Instructions for Transmission/Gear Pressure SWICHGAGE®

TP-8318N
Revised 05-99
Section 05
(00-02-0164)

Please read the following information before installing. A visual inspection of this product for damage during shipping is recommended before mounting.

WARNING

BEFORE BEGINNING INSTALLATION OF THIS MURPHY PRODUCT

- ✓ Disconnect all electrical power to the machine.
- ✓ Make sure the machine cannot operate during installation.
- ✓ Follow all safety warnings of the machine manufacturer.
- ✓ Read and follow all installation instructions.

CAUTION: Certain dangers to human safety and to equipment may occur if some equipment is stopped without pre-warning. It is recommended that monitored functions be limited to alarm-only or to alarm before shutdown.

Base Model Description

20P, 25P, A20P and A25P SWICHGAGE®

The gage pointer makes with an adjustable contact to complete a pilot-duty circuit.

20PE, 25PE, A20PE and A25PE SWICHGAGE®

Features internal snap-acting SPDT switches, instead of the single pole/pointer contacts. When the switch closes on falling pressure, it becomes Set, as pressure rises the switch Resets.

20PABS, 25PABS, A20PABS and A25PABS SWICHGAGE®

Same as 20P, 25P, A20P and A25P with internal SPDT snap-switch for pre-alarm.

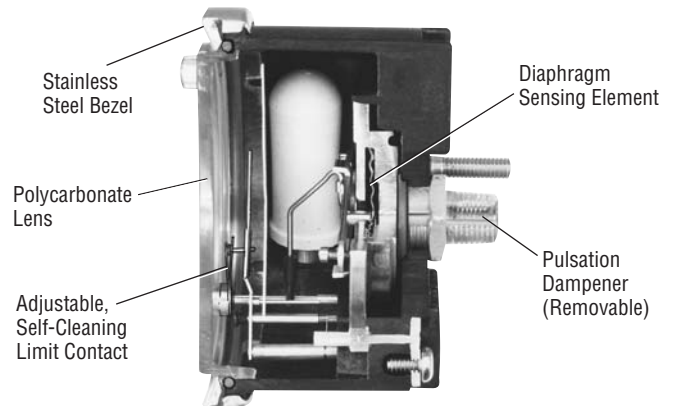

Specifications

Case Material: 20P and 25P Series: *Plated steel.*

A20P and A25P Series: *Polycarbonate.*

Pressure Connection: 1/8-27 NPT.

Contact Rating: Standard is 2A @ 30 VAC/DC resistive (pilot-duty only).
Models 20PE, A20PE, 25PE and A25PE have non-adjustable snap-switch rated 3A @ 30 VDC inductive, 4A @ 125 VAC inductive.

Warranty

A limited warranty on materials and workmanship is given with this FW Murphy product. A copy of the warranty may be viewed or printed by going to www.fwmurphy.com/support/warranty.htm

IMPORTANT Installation Recommendations

SWICHGAGE® Used On Transmission/Clutch Oil Pressure

1. Install the SWICHGAGE® using a Murphy pulsation snubber PD2160 in the pressure connection at the transmission or gear and at the SWICHGAGE®. The snubber helps reduce pressure spikes/surges which will damage the gage sensing element. It also stabilizes the gage readout

through all operating cycles. **Failure to isolate gage in this manner will void Murphy warranty and possibly cause equipment damage.**

2. Models with pre-alarm have two switch points and when used with Murphy SS300 speed switch—allows changing between high and low switch points according to engine RPM. This configuration does away with nuisance alarms when shifting or when at idle—yet maintains maximum pressure protection. See Murphy Application Tip AT-01 for further details.

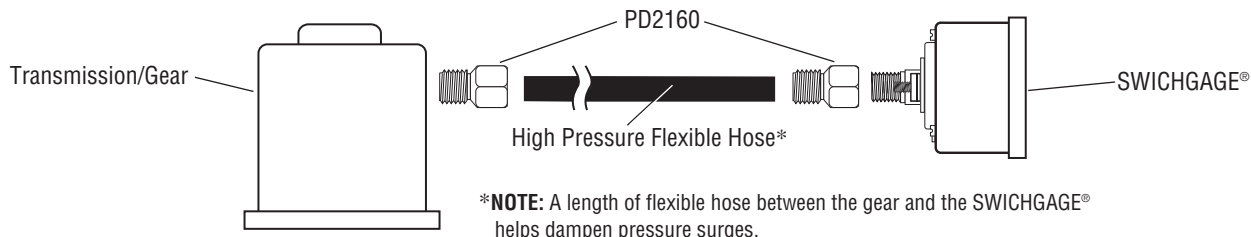

FW Murphy
P.O. Box 470248
Tulsa, Oklahoma 74147 USA
+1 918 317 4100
fax +1 918 317 4266
e-mail sales@fwmurphy.com
www.fwmurphy.com

CONTROL SYSTEMS & SERVICES DIVISION
P.O. Box 1819; Rosenberg, Texas 77471; USA
+1 281 633 4500 fax +1 281 633 4588
e-mail sales@fwmurphy.com

MURPHY DE MEXICO, S.A. DE C.V.
Blvd. Antonio Rocha Cordero 300, Fracción del Aguaje
San Luis Potosí, S.L.P.; México 78384
+52 444 8206264 fax +52 444 8206336
Villahermosa Office +52 993 3162117
e-mail ventas@murphymex.com.mx
www.murphymex.com.mx

FRANK W. MURPHY, LTD.
Church Rd.; Laverstock, Salisbury SP1 1QZ; U.K.
+44 1722 410055 fax +44 1722 410088
e-mail sales@fwmurphy.co.uk
www.fwmurphy.co.uk

MURPHY SWITCH OF CALIFORNIA
41343 12th Street West
Palmdale, California 93551-1442; USA
+1 661 272 4700 fax +1 661 947 7570
e-mail sales@murphyswitch.com
www.murphyswitch.com

MACQUARRIE CORPORATION
1620 Hume Highway
Campbellfield, Vic 3061; Australia
+61 3 9358 5555 fax +61 3 9358 5558
e-mail murphy@macquarrie.com.au



In order to consistently bring you the highest quality, full featured products, we reserve the right to change our specifications and designs at any time.

Printed in U.S.A. 113286N

Free Manuals Download Website

<http://myh66.com>

<http://usermanuals.us>

<http://www.somanuals.com>

<http://www.4manuals.cc>

<http://www.manual-lib.com>

<http://www.404manual.com>

<http://www.luxmanual.com>

<http://aubethermostatmanual.com>

Golf course search by state

<http://golfingnear.com>

Email search by domain

<http://emailbydomain.com>

Auto manuals search

<http://auto.somanuals.com>

TV manuals search

<http://tv.somanuals.com>