

NEC

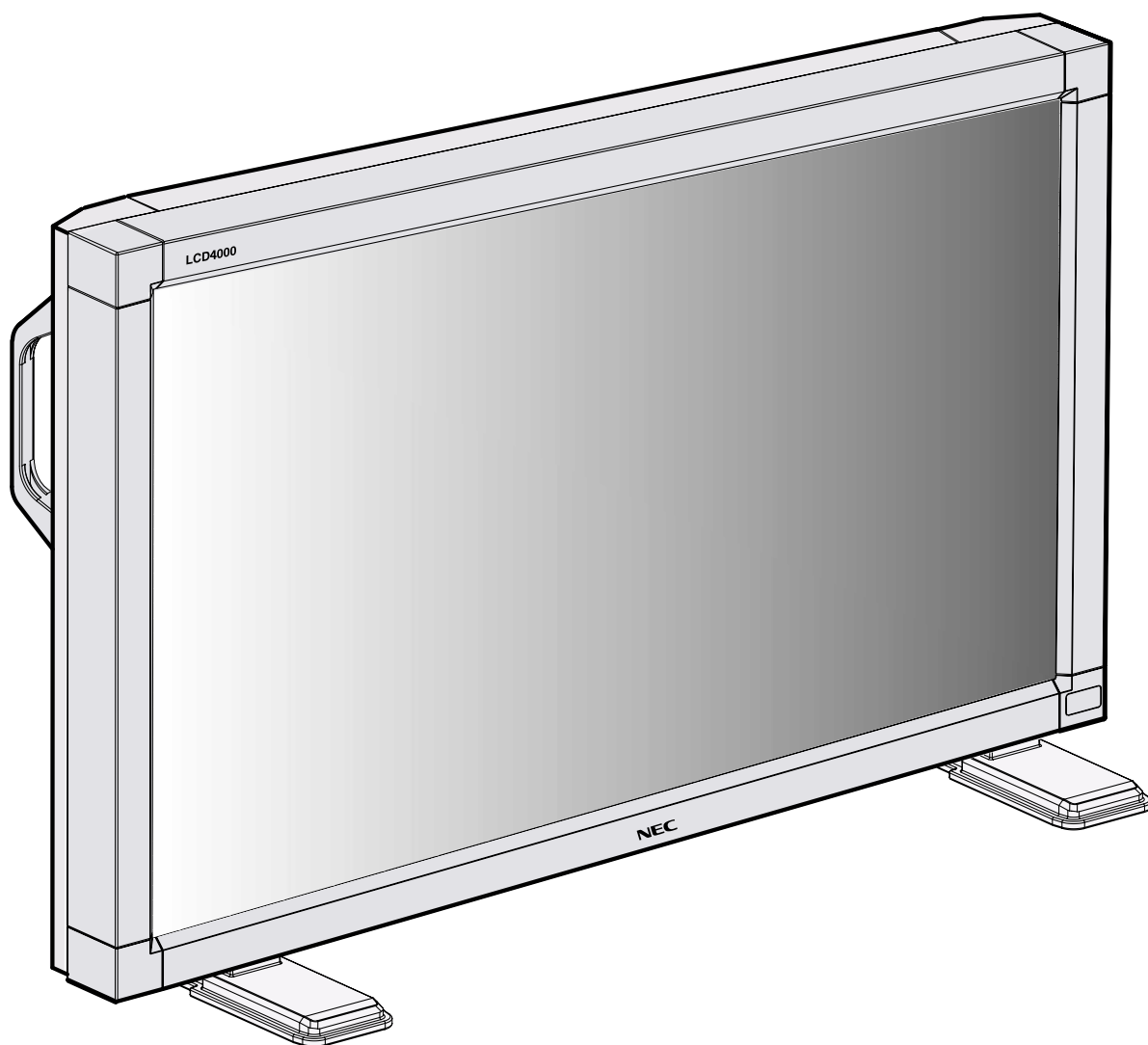

USER'S MANUAL

LCD4000TM

To learn about other special offers, register online at www.necmitsubishi.com/productregistration

Table of Contents

Important Information	1
Safety Precautions, Maintenance, & Recommended Use	2
Contents	3
Attaching LCD Options	4
Parts Name and Functions	
Control Panel	5
Terminal Panel	6
Wireless Remote Control	7
Operating Range for the Remote Control	8
Handling the Remote Control	8
Setup Procedure	9
Connections	
Wiring Diagram	10
Connecting the LCD Monitor to a PC	11
Connecting to a Macintosh Computer	12
Connecting to a Computer with a Digital Output	13
Connecting to a VCR or Laser Disc Player	14
Connecting to a DVD Player	15
Connecting to a Stereo Amplifier	16
Basic Operation	
Power On and Off modes	17
Power Indicator	18
When Using Power Management Function	18
Selecting a video source	18
Picture Size	18
Picture Mode	18
OSM Information	18
OSM (On-Screen-Manager) Controls	
Computer	19
DVD & HD	23
AV INPUT	25
Using the LCD with a Personal Computer (PC)	28
Features	30
Troubleshooting	31
References	32
Specifications	33
Limited Warranty	34

Important Information



WARNING



TO PREVENT FIRE OR SHOCK HAZARDS, DO NOT EXPOSE THIS UNIT TO RAIN OR MOISTURE. ALSO, DO NOT USE THIS UNIT'S POLARIZED PLUG WITH AN EXTENSION CORD RECEPTACLE OR OTHER OUTLETS UNLESS THE PRONGS CAN BE FULLY INSERTED. REFRAIN FROM OPENING THE CABINET AS THERE ARE HIGH VOLTAGE COMPONENTS INSIDE. REFER SERVICING TO QUALIFIED SERVICE PERSONNEL.



CAUTION



CAUTION: TO REDUCE THE RISK OF ELECTRIC SHOCK, MAKE SURE POWER CORD IS UNPLUGGED FROM WALL SOCKET. TO FULLY DISENGAGE THE POWER TO THE UNIT, PLEASE DISCONNECT THE POWER CORD FROM THE AC OUTLET. DO NOT REMOVE COVER (OR BACK). NO USER SERVICEABLE PARTS INSIDE. REFER SERVICING TO QUALIFIED SERVICE PERSONNEL.



This symbol warns user that uninsulated voltage within the unit may have sufficient magnitude to cause electric shock. Therefore, it is dangerous to make any kind of contact with any part inside this unit.



This symbol alerts the user that important literature concerning the operation and maintenance of this unit has been included. Therefore, it should be read carefully in order to avoid any problems.

Canadian Department of Communications Compliance Statement

DOC: This Class B digital apparatus meets all requirements of the Canadian Interference-Causing Equipment Regulations.

C-UL: Bears the C-UL Mark and is in compliance with Canadian Safety Regulations according to CAN/CSA C22.2 No. 950.

FCC Information

1. Use the attached specified cables with the LCD4000 (L40HV201) color monitor so as not to interfere with radio and television reception.
 - (1) Please use the supplied power cord or equivalent to ensure FCC compliance.
 - (2) Please use the supplied shielded video signal cable, 15-pin mini D-SUB to 15-pin mini D-SUB.
2. This equipment has been tested and found to comply with the limits for a Class B digital device, pursuant to part 15 of the FCC Rules. These limits are designed to provide reasonable protection against harmful interference in a residential installation. This equipment generates, uses, and can radiate radio frequency energy, and, if not installed and used in accordance with the instructions, may cause harmful interference to radio communications. However, there is no guarantee that interference will not occur in a particular installation. If this equipment does cause harmful interference to radio or television reception, which can be determined by turning the equipment off and on, the user is encouraged to try to correct the interference by one or more of the following measures:
 - Reorient or relocate the receiving antenna.
 - Increase the separation between the equipment and receiver.
 - Connect the equipment into an outlet on a circuit different from that to which the receiver is connected.
 - Consult your dealer or an experienced radio/TV technician for help.

If necessary, the user should contact the dealer or an experienced radio/television technician for additional suggestions. The user may find the following booklet, prepared by the Federal Communications Commission, helpful: "How to Identify and Resolve Radio-TV Interference Problems." This booklet is available from the U.S. Government Printing Office, Washington, D.C., 20402, Stock No. 004-000-00345-4.

Safety Precautions, Maintenance & Recommended Use

Safety Precautions and Maintenance

FOR OPTIMUM PERFORMANCE, PLEASE NOTE THE FOLLOWING WHEN SETTING UP AND USING THE LCD4000 LCD COLOR MONITOR:

- DO NOT OPEN THE MONITOR. There are no user serviceable parts inside and opening or removing covers may expose you to dangerous shock hazards or other risks. Refer all servicing to qualified service personnel.
- Do not spill any liquids into the cabinet or use your monitor near water.
- Do not insert objects of any kind into the cabinet slots, as they may touch dangerous voltage points, which can be harmful or fatal or may cause electric shock, fire or equipment failure.
- Do not place any heavy objects on the power cord. Damage to the cord may cause shock or fire.
- Do not place this product on a sloping or unstable cart, stand or table, as the monitor may fall, causing serious damage to the monitor.
- When operating the LCD4000 monitor with its AC 220-240V power supply, use a power supply cord that matches the power supply voltage of the AC power outlet being used. The power supply cord you use must have been approved by and comply with the safety standards of your country. (Type H05VV-F 3G 1mm² should be used in Europe)
- In UK, use a BS-approved power cord with molded plug having a black (13A) fuse installed for use with this monitor. If a power cord is not supplied with this monitor, please contact your supplier.
- Do not place any objects onto the monitor and do not use the monitor outdoors.
- The inside of the fluorescent tube located within the LCD monitor contains mercury.
- Do not bend power cord.
- Do not use monitor in high temperature, humid, dusty, or oily areas.
- If glass is broken, handle with care.
- Do not cover vent on monitor.
- If monitor or glass is broken, do not come in contact with the liquid crystal and handle with care.
- Allow adequate ventilation around the monitor so that heat can properly dissipate. Do not block ventilated openings or place the monitor near a radiator or other heat sources. Do not put anything on top of monitor.
- The power cable connector is the primary means of detaching the system from the power supply. The monitor should be installed close to a power outlet which is easily accessible.
- Handle with care when transporting. Save packaging for transporting.
- Please follow the bylaws or rules of your municipality to dispose of the tube properly.
- Keep the holes on the back of the LCD clean of dirt and dust. It is recommended to wipe holes with a soft cloth a minimum of once per year.

CAUTION

Immediately unplug your monitor from the wall outlet and refer servicing to qualified service personnel under the following conditions:

- When the power supply cord or plug is damaged.
- If liquid has been spilled, or objects have fallen into the monitor.
- If the monitor has been exposed to rain or water.
- If the monitor has been dropped or the cabinet damaged.
- If the monitor does not operate normally by following operating instructions.

Recommended Use

CAUTION



CORRECT PLACEMENT AND ADJUSTMENT OF THE MONITOR CAN REDUCE EYE, SHOULDER AND NECK FATIGUE. CHECK THE FOLLOWING WHEN YOU POSITION THE MONITOR:

- For optimum performance, allow 20 minutes for warm-up.
- Rest your eyes periodically by focusing on an object at least 20 feet away. Blink often.
- Position the monitor at a 90° angle to windows and other light sources to minimize glare and reflections.
- Clean the LCD monitor surface with a lint-free, nonabrasive cloth. Avoid using any cleaning solution or glass cleaner.
- Adjust the monitor's brightness and contrast controls to enhance readability.
- Avoid displaying fixed patterns on the monitor for long periods of time to avoid image persistence (afterimage effects).
- Get regular eye checkups.
- The lamp of backlight contains mercury. Please handle it appropriately in case of disposal.

Ergonomics

To realize the maximum ergonomics benefits, we recommend the following:

- Use the preset Size and Position controls with standard signals
- Use the preset Color Setting
- Use non-interlaced signals with a vertical refresh rate between 58-62Hz
- Do not use primary color blue on a dark background, as it is difficult to see and may produce eye fatigue to insufficient contrast

For more detailed information on setting up a healthy work environment, write the American National Standard for Human Factors Engineering of Visual Display Terminal Workstations – ANSI-HFS Standard No. 100-1988 – The Human Factors Society, Inc. P.O. Box 1369, Santa Monica, California 90406.

Contents

Your new LCD4000™ monitor box* should contain the following:

- LCD monitor
- Power Cord (3m)
- Video Signal Cable – SC-B113 (4m)
- User's Manual
- Wireless Remote Control and AA Batteries
- Clamper x 2
- Screw (M4 x 10) x 2
- CD-ROM
- Ferrite Core x 2
- Stand for the Independence x 2
- Screw (M5 x 40) x 4

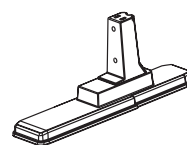
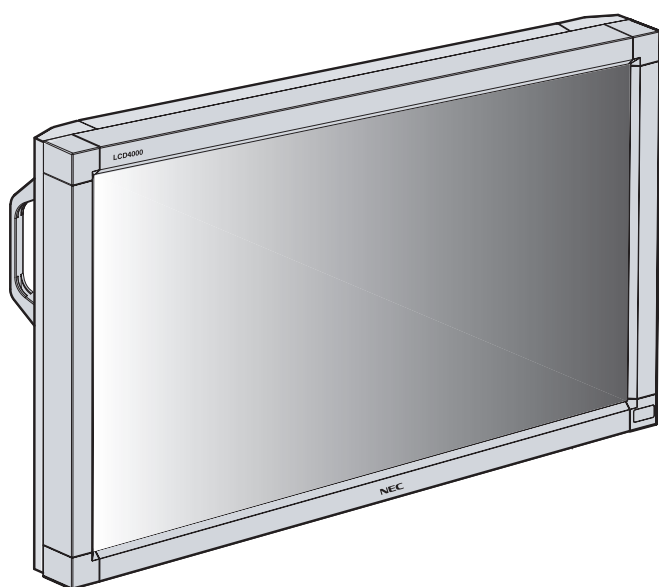

Stand for the Independence x 2



Screw (M5 x 40) for stand x 4

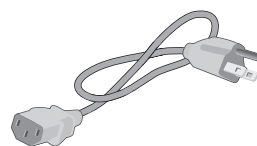

Power Cord

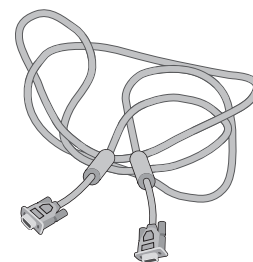

Video Signal Cable (D-SUB to D-SUB Cable)



Screw (M4 x 10) x 2



Clamper x 2

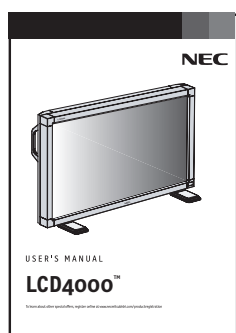

User's Manual



CD-ROM



Wireless Remote Control and AA Batteries



Ferrite Core x 2



Band

*Install an attached stand at the time of unpacking when it uses with the stand.
*Remember to save your original box and packing material to transport or ship the monitor.

The following components are available to use with the LCD4000. To obtain the optional components and additional information, contact Customer Service at (800) 632-4662.

- Macintosh Cable Adapter
- External Speakers

Attaching LCD Options

You can attach mounting accessories to the LCD monitor in one of the following two ways:

1. In the upright position

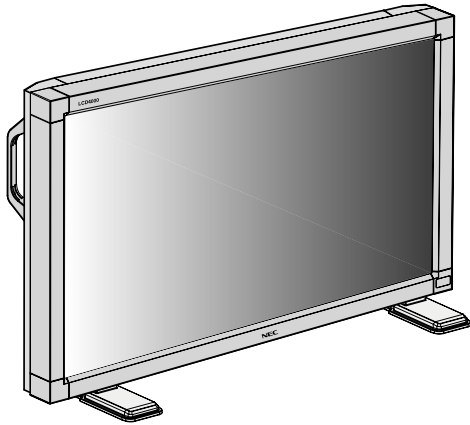

2. Lay the screen face down

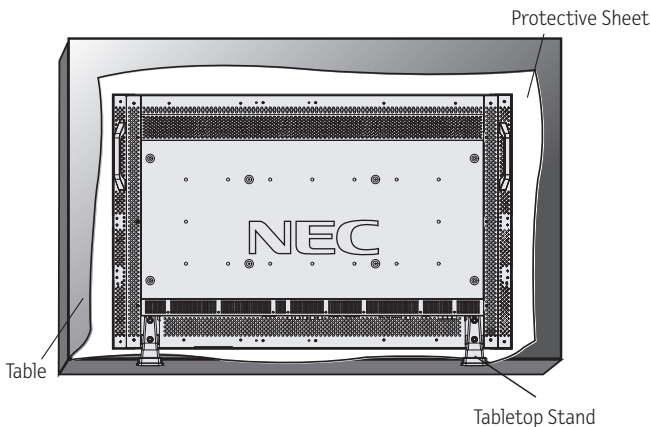

To avoid damaging the screen face, place the protective sheet on the table to lay the LCD on. The protective sheet was wrapped around the LCD in the original packaging.

This device cannot be used or installed without the Tabletop Stand or other mounting accessory. For proper installation it is strongly recommended to use a trained, NEC authorized service person. Failure to follow NEC standard mounting procedures could result in damage to the equipment or injury to the user or installer. Product warranty does not cover damage caused by improper installation. Failure to follow these recommendations could result in voiding your warranty.

When using mounting accessories, other than NEC compliant and approved, they must be VESA-compatible mounting method. NEC strongly recommends using screws M6 size and 8mm in length. If using screws longer than 8mm, check the depth of the hole. (Recommended Fastern Force: 274 ~ 362N*cm)
NEC recommends using mounting interface that comply with UL1678 standard in North America.

Ventilation Requirements for enclosure mounting

To allow heat to disperse, leave space between surrounding objects as shown in the diagram to the right.

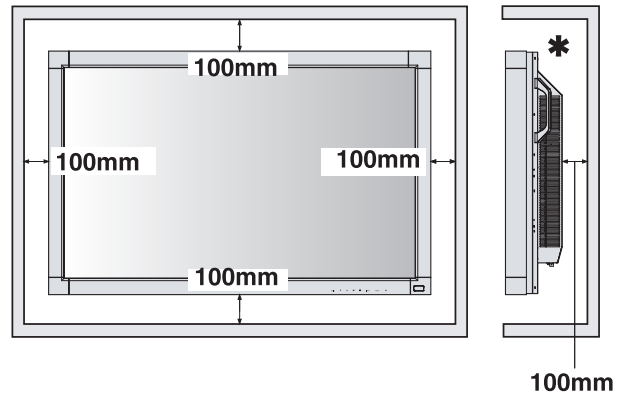

*Ambient temperature should be less than 40 deg C

To avoid falling down

Fasten the LCD monitor to a wall using a cord or chain which is sufficient to support the weight of the LCD monitor (approx. 31.5kg).

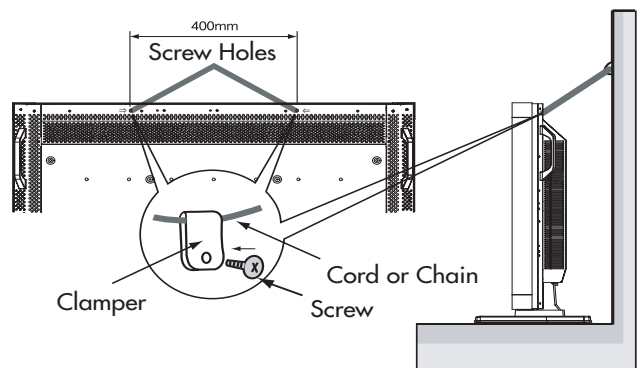

Before moving the LCD monitor, the cord or chain should be removed.

Parts Name and Functions

Control Panel

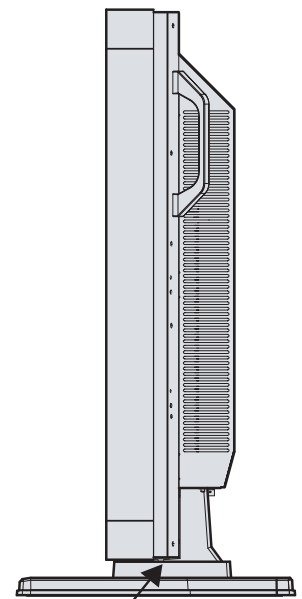
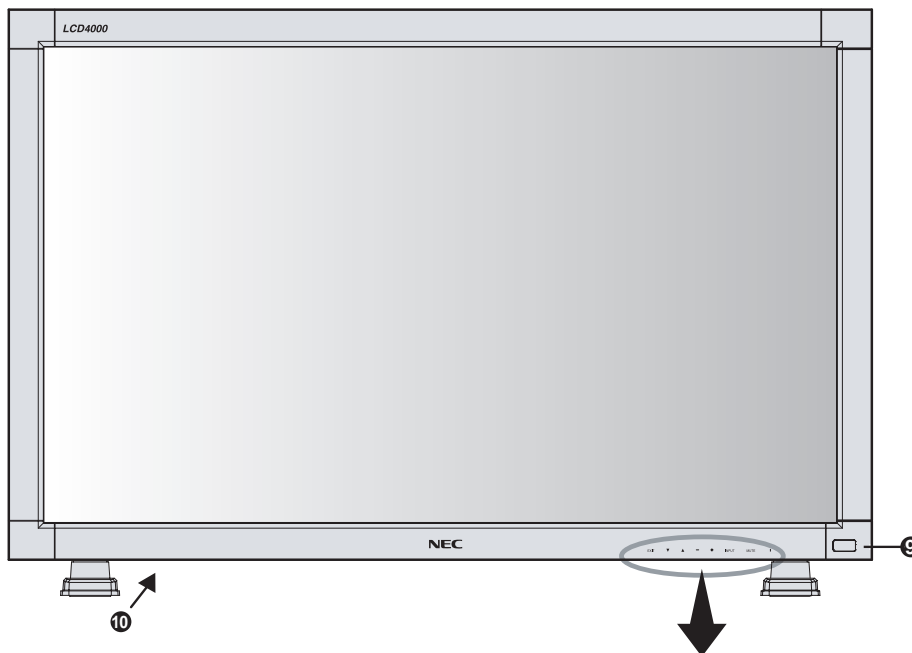

Button Location

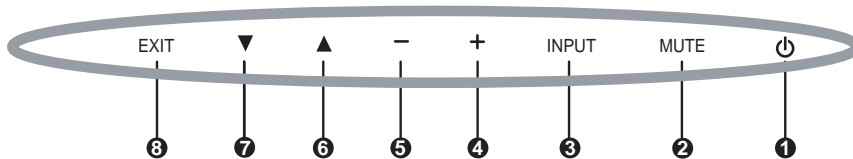

① POWER button (⏻)

Switches the power on/off. See also page 17.

② MUTE button

Switches the audio mute ON/OFF.

③ INPUT button

Acts as SET button with OSM menu.

Selects the signal connected with the RGB input connector. (Toggle switches between [RGB1], [RGB2], [RGB3], [DVD/HD], or [VIDEO].)

④ PLUS (+) button

Acts as (+) button to increase the adjustment with OSM menu. Increase the audio output level when the OSM menu is turned off.

⑤ MINUS (-) button

Acts as (-) button to decrease the adjustment with OSM menu. Decrease the audio output level when the OSM menu is turned off.

⑥ UP (▲) button

Activates the OSM menu when the OSM menu is turned-off. Acts as ▲ button to move the highlighted area up to select the adjustment with OSM menu.

⑦ DOWN (▼) button

Activates the OSM menu when the OSM menu is turned-off. Acts as ▼ button to move the highlighted area down to select the adjustment with OSM menu.

⑧ EXIT button

Activates the OSM menu when the OSM menu is turned-off. Acts as EXIT button to move to previous menu with OSM menu.

⑨ Remote control sensor and Power indicator

Receives the signal from the remote control (when using the wireless remote control). See also page 8. Glows green when the LCD monitor is in active and glows red when the LCD is in POWER OFF mode. When the LCD is in power save mode, it will glow both green and red.

⑩ Main Power Switch

Seesaw Switch for the main power on/off.

⑪ Control Key Lock Mode

This control completely locks out access to all Control Key functions after three (3) seconds. To activate the control key lock function, press both of "▼" and "▲" and hold down simultaneously. To resume back to user mode, press both "▼" and "▲" and hold simultaneously for three (3) seconds.

Parts Name and Functions –continued

Terminal Panel

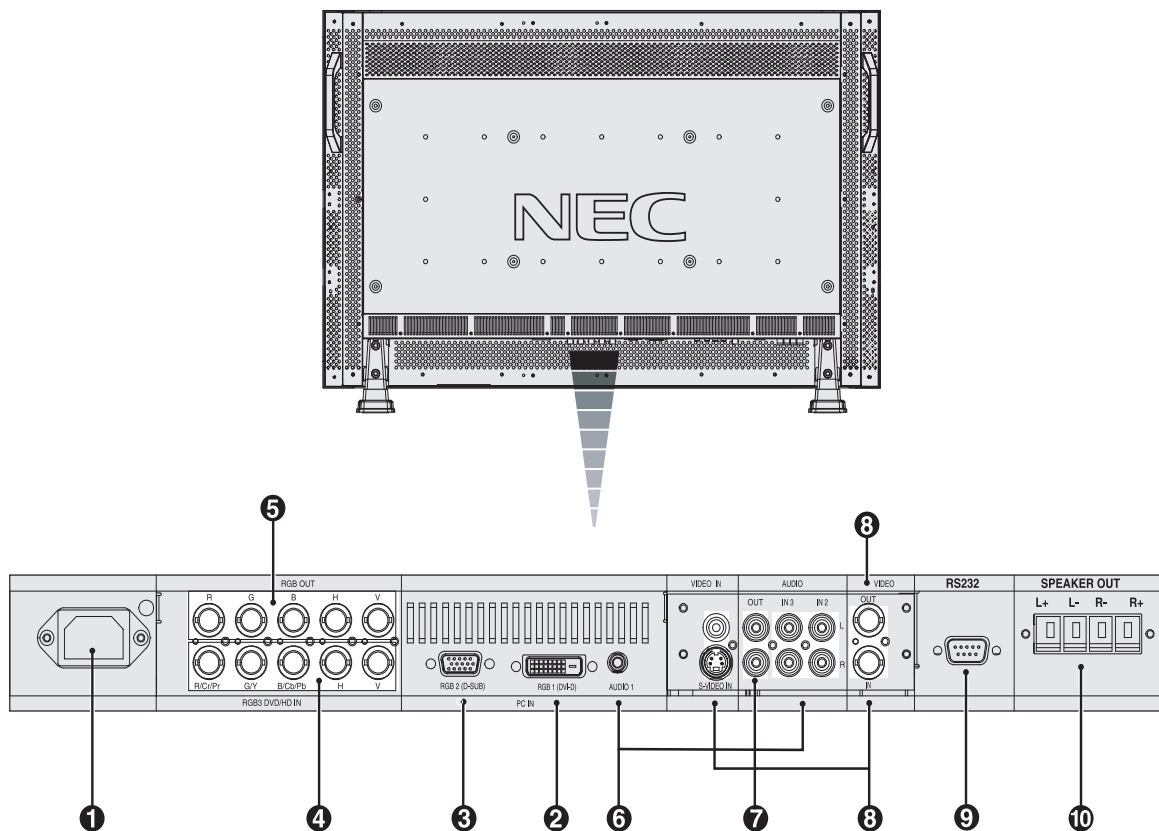

❶ AC IN connector

Connects with the supplied power cord.

❷ RGB 1 IN (DVI-D)

To input digital RGB signals from a computer having a digital RGB output.

* This connector does not support analog input.

❸ RGB 2 IN (mini D-Sub 15 pin)

To input a analog RGB signals from a personal computer or other RGB equipment.

❹ RGB 3 DVD/HD [R/Cr/Pr, G/Y, B/Cb/Pb, H, V] (BNC)

IN connector: To input the analog RGB signals or signals from other RGB equipment. Also for connecting equipment such as a DVD player or HDTV laser disc player. A Sync-on-Green signal can be connected to the G/Y connector.

❺ RGB OUT connector (BNC)

To output the signal from the RGB 2 or RGB 3 DVD/HD IN connector.

❻ AUDIO IN 1,2,3

To input audio signal from external equipment such as a computer, VCR or DVD player.

❼ AUDIO OUT

To output the audio signal from the AUDIO IN 3 jack.

❽ VIDEO

VIDEO IN connector (BNC and RCA): To input a composite video signal. BNC and RCA are not available at the same time. (Use only one input).

VIDEO OUT connector (BNC): To output the composite video signal from the VIDEO IN connector.

S-VIDEO IN connector (DIN 4 pin): To input the S-video (Y/C separate signal).

❾ EXTERNAL CONTROL (mini D-Sub 9 pin) RS232

IN connector: Use when operating the LCD monitor from the RGB equipment like a computer.

❿ EXTERNAL SPEAKER TERMINAL

To output the audio signal from AUDIO 1, 2 or 3 jack.

Parts Name and Functions –continued

Wireless Remote Control

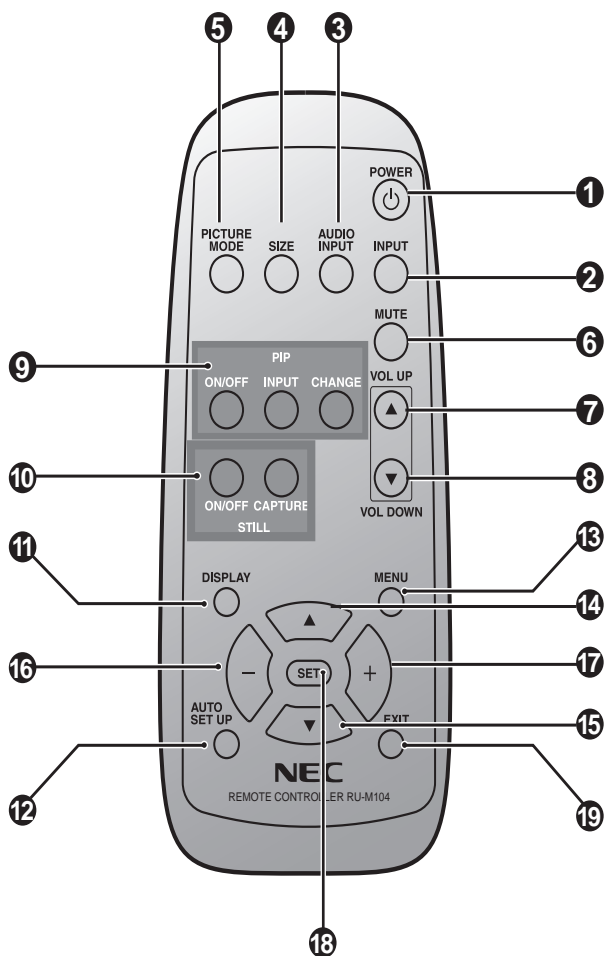

1 POWER button

Switches the power on/off.

* If Power Indicator is not glowing, then no controls will work.

2 INPUT button

Selects from input signal, [RGB1], [RGB2], [RGB3], [DVD/HD], [VIDEO].

3 AUDIO INPUT button

Selects from input audio signal, [AUDIO1], [AUDIO2], [AUDIO3]

4 SIZE button

Selects picture size, [FULL], [NORMAL], [WIDE]. See page 18.

5 PICTURE MODE button

Selects from picture mode, [HIBRIGHT], [STANDARD], [sRGB], [CINEMA].

HIBRIGHT: for moving image such as DVD

STANDARD: for images

sRGB: for text based images

CINEMA: for movies. See page 18.

6 MUTE button

To on/off the mute function.

7 VOLUME UP button

Increase the audio output level.

8 VOLUME DOWN button

Decrease the audio output level.

9 PIP (Picture In Picture) button

ON/OFF button: Toggle switches between PIP-ON/POP-ON/OFF.

INPUT button: Select the 'picture in picture' input signal.

CHANGE button: Replaces to the main picture and sub picture.

Sub Picture

	RGB1	RGB2	RGB3	DVD/HD	VIDEO
Main Picture	RGB1	-	-	✓	✓
	RGB2	-	-	-	✓
	RGB3	-	-	-	✓
	DVD/HD	-	-	-	-
	VIDEO	-	✓	✓	-

Note: The aspect ration of PIP synchronizes with a setup in the Main Picture.

10 STILL button

ON/OFF button: To on/off the still picture mode.

CAPTURE button: Capture the new picture.

11 DISPLAY button

To on/off the OSM information. See page 18.

12 AUTO SETUP button

To enter the auto setup menu. See page 21.

13 MENU button

To on/off the menu mode.

14 UP button

Acts as ▲ button to move the highlighted area up to select the adjustment with OSM menu.

Small screen which adjusted "PIP" mode moves up.

15 DOWN button

Acts as ▼ button to move the highlighted area down to select the adjustment with OSM menu.

Small screen which adjusted "PIP" mode moves down.

16 MINUS button decrease

Acts as (-) button to decrease the adjustment with OSM menu.

Small screen which adjusted "PIP" mode moves left.

17 PLUS button increase

Acts as (+) button to increase the adjustment with OSM menu.

Small screen which adjusted "PIP" mode moves right.

18 SET button

Acts as SET button with OSM menu.

19 EXIT button

Turn to previous menu with OSM menu.

Parts Name and Functions *-continued*

Operating Range for the Remote Control

Point the top of the remote control toward the LCD monitor's remote sensor during button operation.

Use the remote control within a distance of about 7 m/23 ft. from the front of the LCD monitor's remote control sensor and at a horizontal and vertical angle of within 30° within a distance of about 3 m/10 ft.

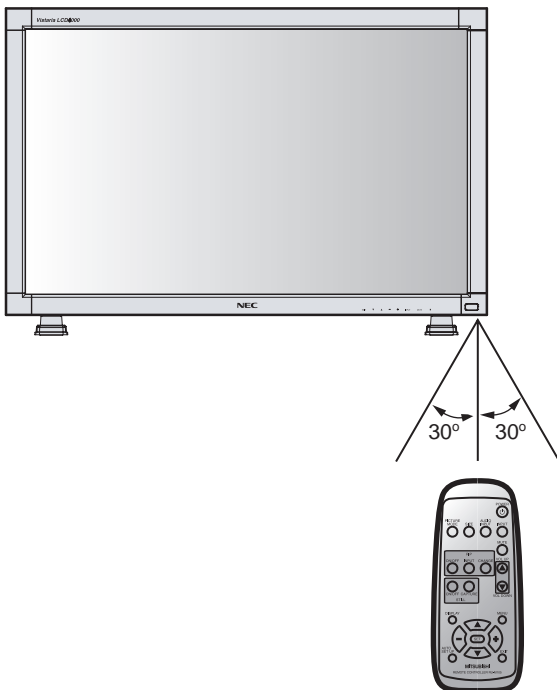

Caution

The remote control system may not function when direct sunlight or strong illumination strikes the remote control sensor of the LCD monitor, or when there is an object in the path.

Handling the remote control

- * Other than to install the batteries, do not open the remote.
- * Do not allow water or other liquid to splash onto the remote control. If the remote control gets wet, wipe it dry immediately.
- * Avoid exposure to heat and steam.

Setup Procedure

1. Determine the installation location

CAUTION

Installing your LCD display must be done by a qualified technician. Contact your dealer for more information.

CAUTION

MOVING OR INSTALLING THE LCD MONITOR MUST BE DONE BY TWO OR MORE PEOPLE. Failure to follow this caution may result in injury if the LCD monitor falls.

IMPORTANT

Lay the protective sheet, which was wrapped around the LCD monitor when it was packaged, beneath the LCD monitor so as not to scratch the panel.

2. Install the remote control batteries

The remote control is powered by 1.5V AA batteries. To install or replace batteries:

1. Press and slide to open the cover.
2. Align the batteries according to the (+) and (-) indications inside the case.
3. Replace the cover.

- ① Remove the cover ② Insert the batteries ③ Replace the cover

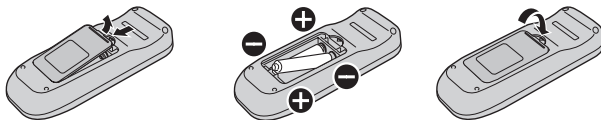

CAUTION

Incorrect usage of batteries can result in leaks or bursting. NEC recommends the following battery use:

- Place "AA" size batteries matching the + and - signs on each battery to the + and - signs of the battery compartment.
- Do not mix battery brands.
- Do not combine new and old batteries. This can cause a shorten life or liquid leakage of batteries.
- Remove dead batteries immediately to prevent battery acid from leaking into the battery compartment. Don't touch exposed battery acid, it cause damage to your skin.

NOTE: If you do not intend to use the Remote Control for a long period, remove the batteries.

3. Connect external equipment (See page 10-16)

- To protect the connected equipment, turn off the main power before making connections.
- Refer to your equipment user manual.

4. Connect the supplied power cord

- The equipment should be installed close to a power outlet and should be easily accessible.
- Fully insert the prongs into the power outlet socket. Loose connection may cause image degradation.

5. Switch on the power of all the attached external equipment

When connected with a computer, switch on the power of the computer first.

6. Operate the attached external equipment

Display the signal on the external equipment you wish.

7. Adjust the sound

Make adjustments when adjustment of the volume is required.

8. Adjust the screen (See pages 19-27)

Make adjustments when adjustment of the screen display position.

9. Adjust the image (See page 19-27)

Make adjustments when picture adjustment such as the brightness or contrast is required.

10. When monitor is installed in the portrait position

- Remove the stand (feet).
- Left edge should be upper from front view.

11. When installing the monitor to a wall

How to remove the stand

1. Spread the protective sheet on the flat surface, such as a desk.
2. Place monitor on the protective sheet.
3. Remove 2 screws by screwdriver and place them in a safe place for reuse.

How to install stand

1. Please turn monitor off.
2. Insert claws of monitor to stand holes until clicks.
3. Fasten 2 screws(M5 x 40mm) on both sides of the monitor.
Torque 280 ~ 300N•cm.

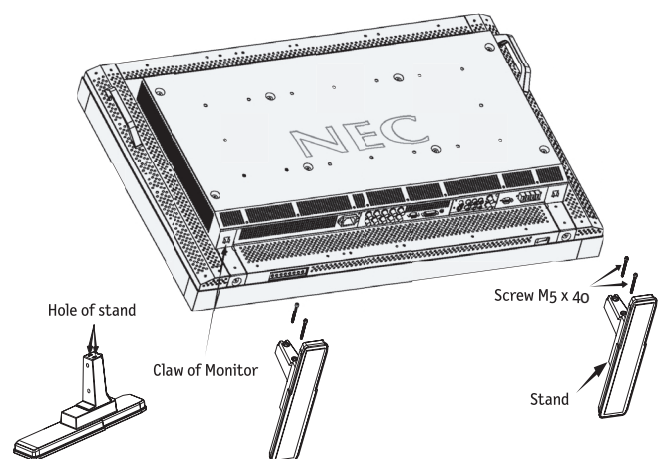

Connections

Before making connections:

- * First turn off the power of all the attached equipment and make connections.
- * Refer to the user manual included with each separate piece of equipment.

Wiring Diagram

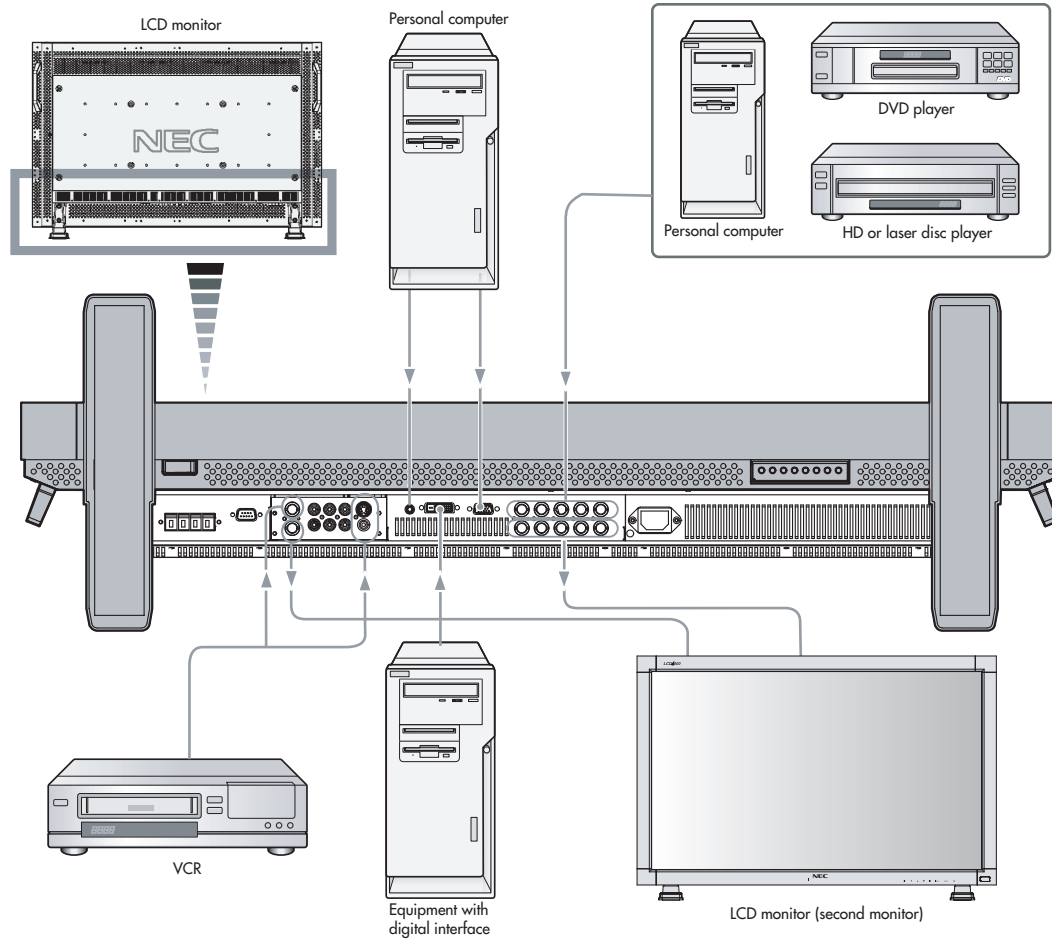

Attaching the Ferrite Core

Attach the Ferrite Core to PC Audio Cable and S-VIDEO Cable. Use of the cable without mounting the ferrite core will result in the occurrence of noise.

• For PC Audio Cable

- 1 Open the ferrite core and clamp it on the PC Audio cable.
- 2 Close the ferrite core.



Mounting Position of Ferrite Core

Attach the Ferrite Core to the end of PC Audio Cable. Only AUDIO 1 side of monitor.

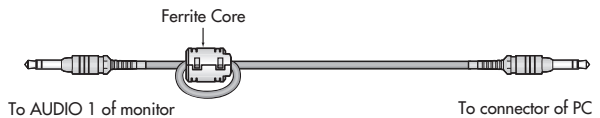

• For S-VIDEO Cable

- 1 Open the ferrite core and clamp it on the S-VIDEO Cable.
- 2 Close the ferrite core.



Attach the Ferrite Core to the end of S-VIDEO Cable. Only S-VIDEO IN side of monitor.



Connections *—continued*

Connecting the LCD Monitor to a PC

Connecting your computer to your LCD monitor will enable you to display your computer's screen image. Some video cards may not display an image correctly.

- To connect the RGB 2 IN connector (mini D-sub 15 pin) on the LCD monitor, use the provided RGB signal cable (mini D-sub 15 pin to mini D-sub 15 pin).
- To connect the RGB 3 DVD/HD IN connector (BNC) on the LCD monitor, use a signal cable (mini D-sub 15 pin to BNC x 5). Select RGB 3 from the INPUT button.

When connecting one or more LCD monitors, use the RGB OUT connector (BNC).

- The AUDIO IN 1, 2 and 3 can be used for audio input. For connection, select AUDIO 1, 2 or 3 from the AUDIO INPUT button.

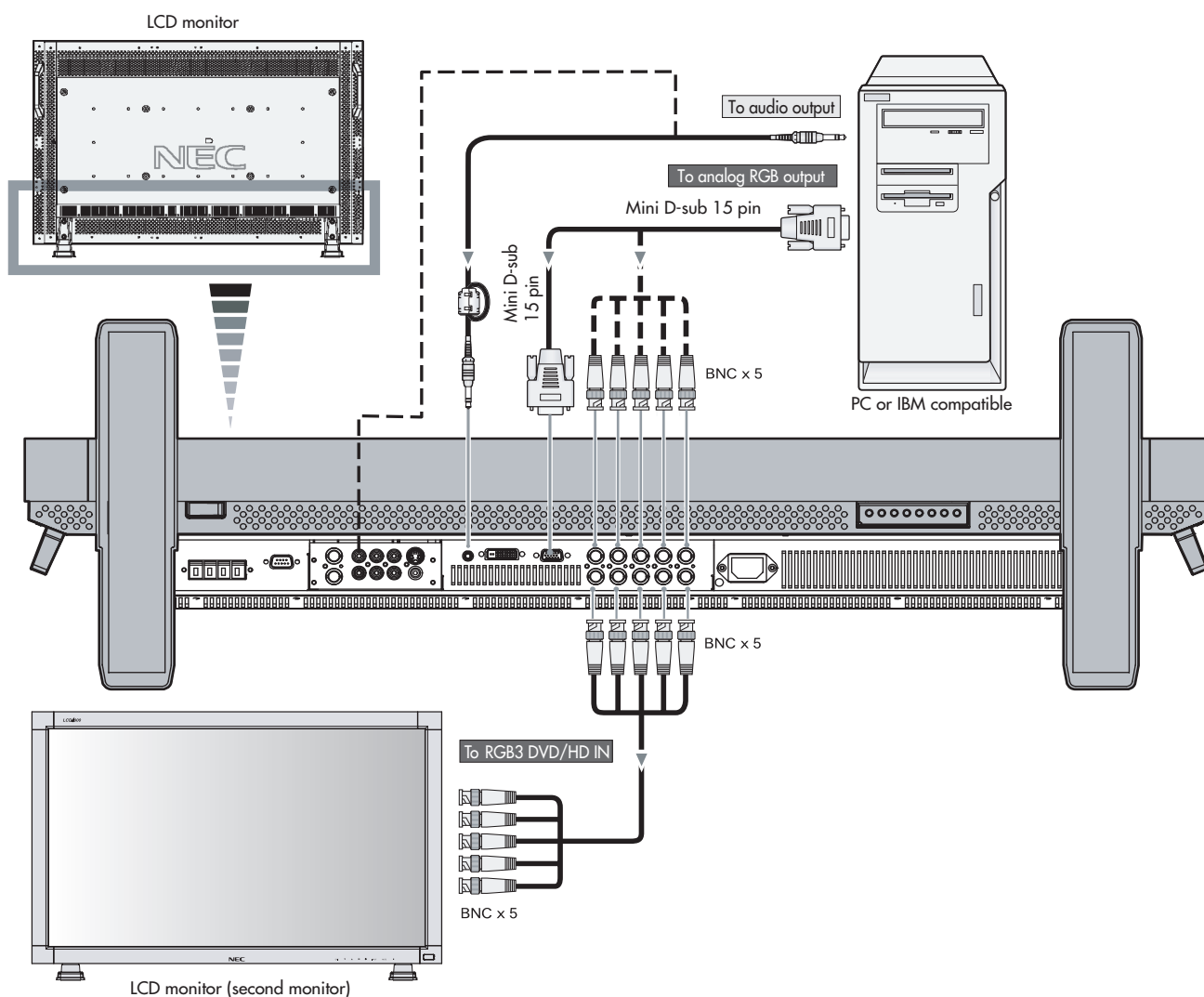

Connections *-continued*

Connecting to a Macintosh® Computer

Connecting your Macintosh® computer to your LCD monitor will enable you to display your computer's screen image. Some video cards or drivers may not display images correctly.

- To connect the RGB 2 IN connector (mini D-sub 15 pin) on the LCD monitor, use the provided RGB signal cable (mini D-sub 15 pin to mini D-sub 15 pin).
For older Macintosh® computers, use Macintosh cable adapter to connect to your Macintosh's video port.
NOTE: To obtain the Macintosh cable adapter call NEC-Mitsubishi Electronics Display of America, Inc. at (800) 632-4662
- To connect the RGB 3 DVD/HD IN connector (BNC) on the LCD monitor, use the signal cable available separately (mini D-sub 15 pin to BNC x 5).
- If you use with a Macintosh PowerBook, set "Mirroring" to off.
Refer to your Macintosh's owner's manual for more information about your computer's video output requirements and any special identification or configuring your monitor's image and monitor may require.
- The AUDIO IN 1, 2 and 3 can be used for audio input. For connection, select AUDIO 1, 2 or 3 from the AUDIO INPUT button.

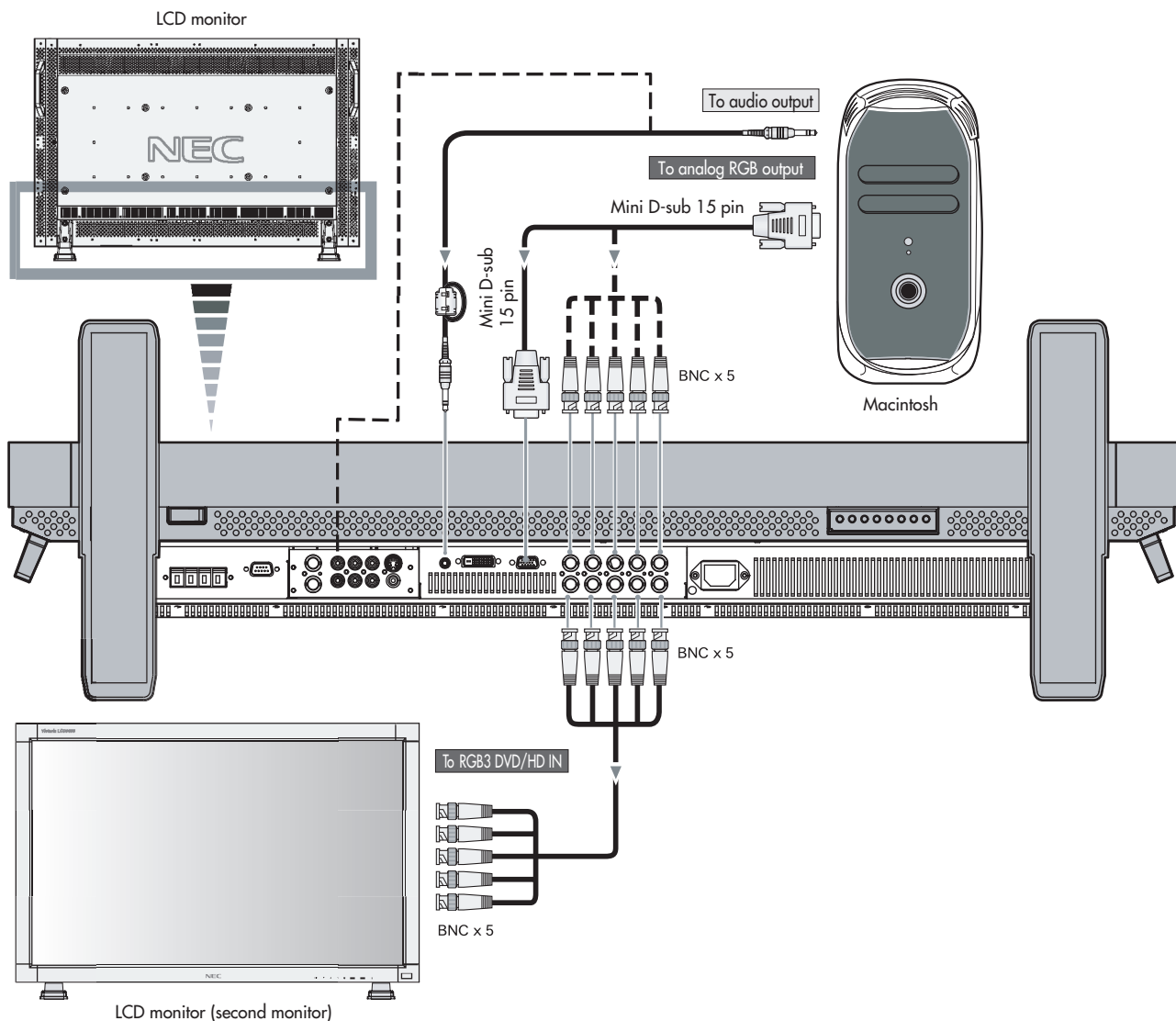

Connections *—continued*

Connecting to a Computer with a Digital Output

Connections can be made with equipment that is equipped with a digital interface compliant with the DVI (Digital Visual Interface) standard.

- The RGB 1 IN connector also accepts a DVI-D cable.
- Input TMDS signals conforming to DVI standards.
- To maintain display quality, use a cable recommended by DVI standards.
- The AUDIO IN 1, 2 and 3 can be used for audio input. For connection, select AUDIO 1, 2 or 3 from the AUDIO INPUT button.

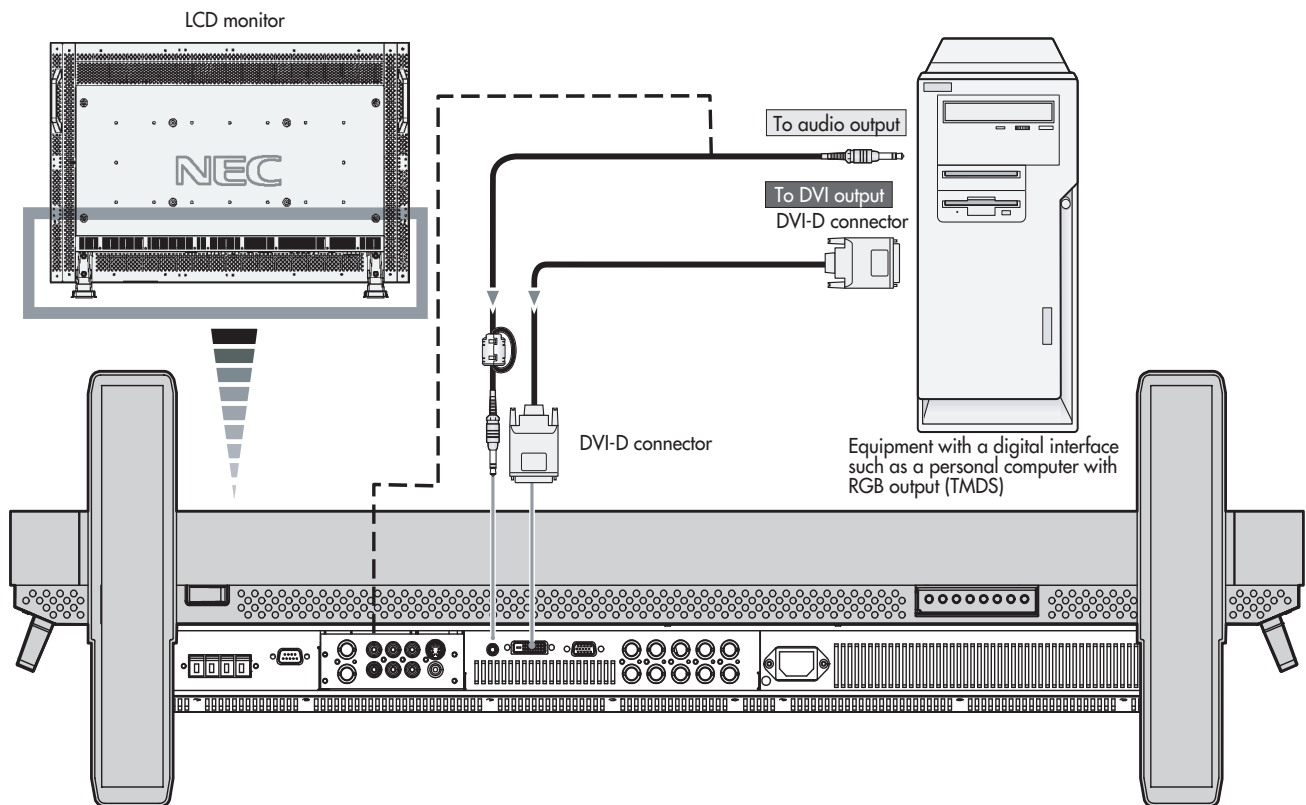

Connections *-continued*

Connecting to a VCR or Laser Disc Player

Connecting your VCR or laser disc player to your LCD monitor will enable you to display your VCR or laser disc player video. Refer to your VCR or laser disc player owner's manual for more information.

- Video signals can be connected to either the VIDEO IN [RCA or BNC] or the S-VIDEO IN connector.
NOTE: If S-VIDEO and RCA are both connected, S-VIDEO will have priority.
- Video output will be from the OUT connector that has been set here.
- When connecting one or more LCD monitors, use the VIDEO OUT connectors (BNC).
- The AUDIO IN 2 and 3 can be both used for audio input. For connection, select [AUDIO 2] or [AUDIO 3] from the AUDIO INPUT button.

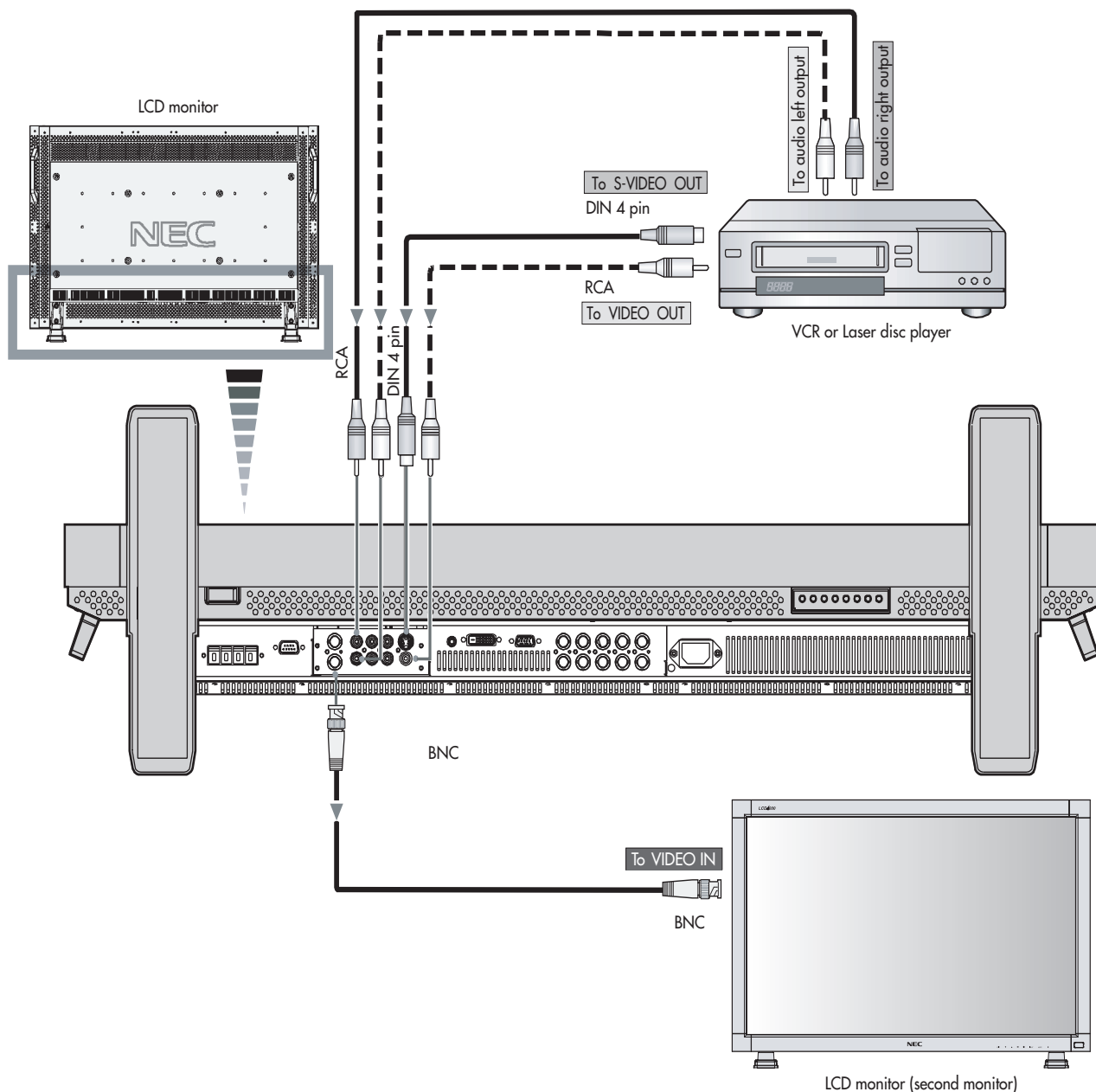

Connections *—continued*

Connecting to a DVD Player

Connecting your DVD player to your LCD monitor will enable you to display your DVD video. Refer to your DVD player owner's manual for more information.

- To connect the RGB 3 DVD/HD In connector (BNC) on the LCD monitor, use a separately available BNC connector cable. You will need a BNC-to-RCA adapter to connect a DVD player with an RCA pin jack to the BNC connector cable (not provided). Some DVD players may have different connectors, such as Cr/Pr, Y and Cb/Pb. Select [DVD/HD] input mode from the INPUT button. When connecting one or more LCD monitors, use the RGB 3 OUT connectors (BNC). The AUDIO IN 2 and 3 (both RCA) can be used for audio input. For connection, select [AUDIO 2] or [AUDIO 3] from the AUDIO INPUT button.

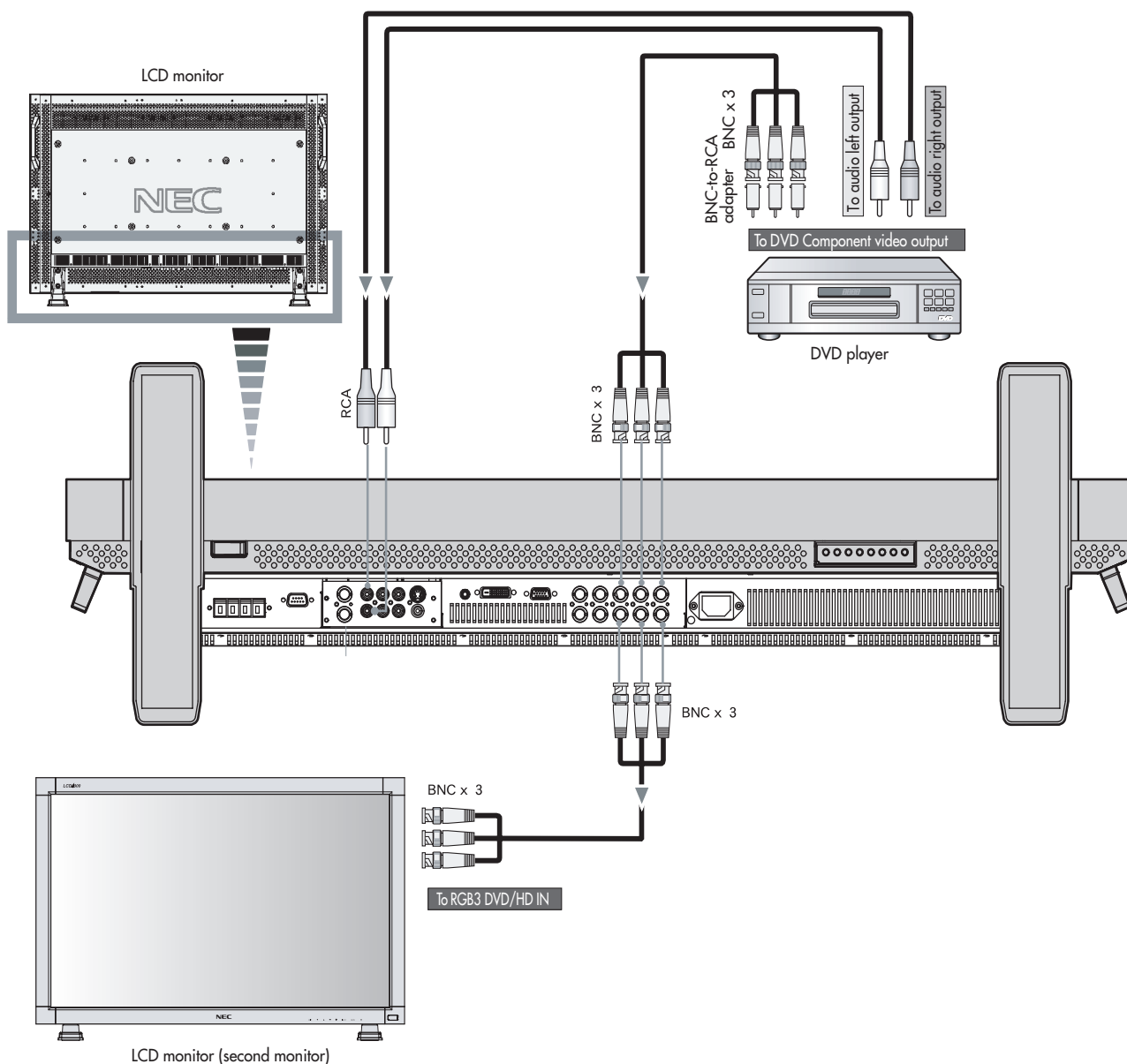

Connections *-continued*

Connecting to a Stereo Amplifier

You can connect your stereo amplifier to your LCD monitor. Refer to your amplifier owner's manual for more information.

- Turn on the LCD monitor and the amplifier only after all hookups have been made.
- Use an RCA cable to connect the AUDIO OUT connector (RCA) on the LCD monitor and the audio input on the amplifier.
- Do not reverse the audio left and right jacks.
- The AUDIO IN 3 used for audio input.
- The AUDIO OUT jack outputs sound for the AUDIO IN 3 only.

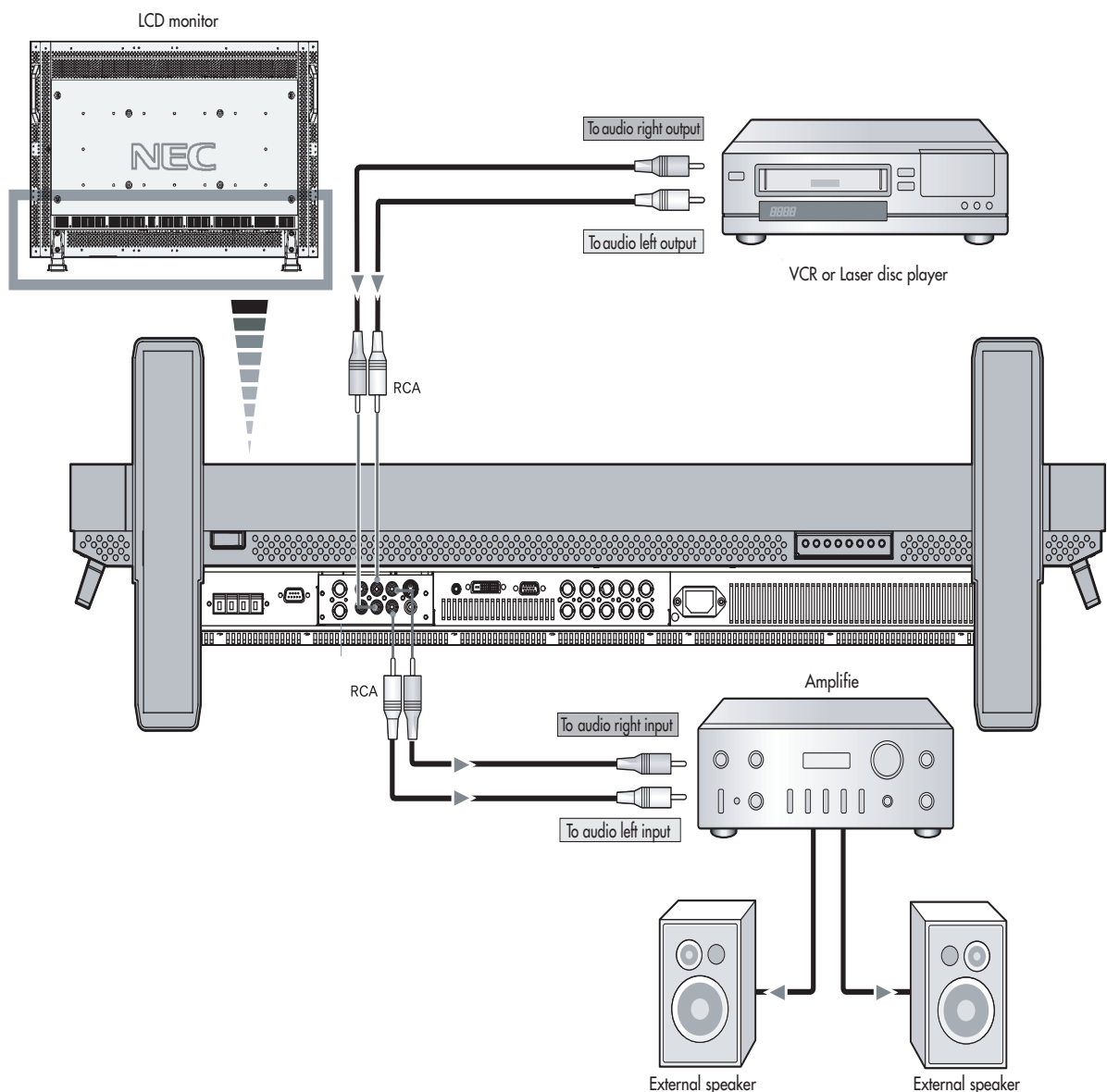

Basic Operation –Power ON and OFF Modes

The LCD monitor power indicator will turn green while powered on or red in off mode. The monitor can be powered on or off using the following three options:

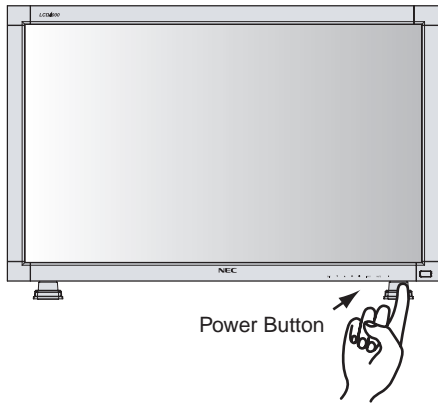

1. Pressing the power button.

NOTE: Before operating the remote control, be sure to turn on the Main Power Switch on the LCD monitor.

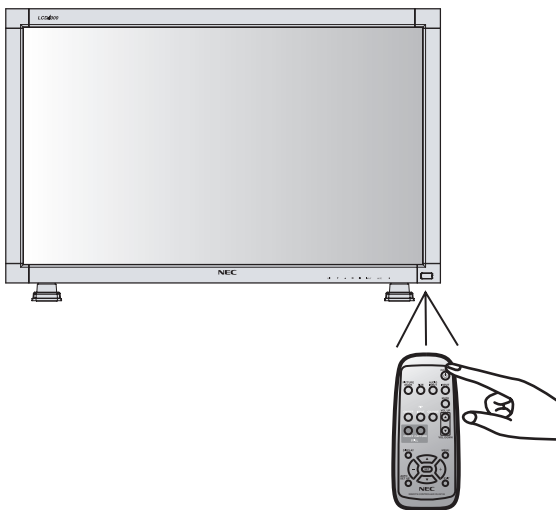

2. Using the remote control

NOTE: Before operating the remote control, be sure to turn on the Main Power Switch on the LCD monitor.

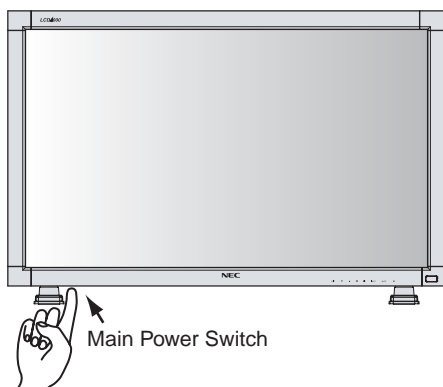

3. Pressing the Main Power Switch.

NOTE: When the Main Power Switch is used to power off the LCD, the remote control and the power switch will not activate the on mode. Be sure to turn the Main Power Switch to the on mode before using these two options.

Basic Operation *-continued*

Power Indicator

Power Indicator

	Status
Power ON	Green
Power OFF	Red
Power Standby	Red and Green

When Using Power Management Function

The LCD monitor follows the VESA approved DPMS Power Management function.

The power management function is an energy saving function that automatically reduces the power consumption of the display when the keyboard or the mouse has not been used for a fixed period of time.

Selecting a Video Source

To view a video source:

Use the input button to set [VIDEO].

Use the COLOR SYSTEM menu to set, [PAL], [SECAM], in according to your video format.

Picture Size

RGB 1, 2, 3 FULL* ↔ NORMAL
 DVD/HD, VIDEO WIDE → FULL → NORMAL

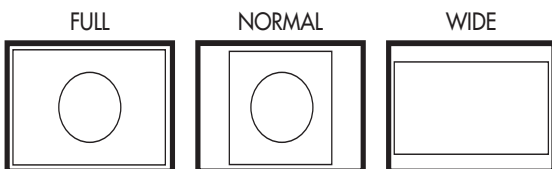

*NOTE: FULL only in W-XGA (1280 x 768) in RGB 1, 2, 3

Picture Mode

RGB 1, 2, 3 HIBRIGHT → sRGB → STANDARD
 DVD/HD, VIDEO HIBRIGHT → CINEMA → STANDARD

OSM Information

RGB1, 2, 3

RGB2
 1024 x 768
 48kHz 60Hz
 AUDIO : 1
 SCREEN SIZE : FULL

- ← Video Input mode
- ← Input signal Information
- ← Audio input mode
- ← Picture Size mode

DVD/HD

DVD/HD
 AUDIO : 3
 SCREEN SIZE : WIDE

- ← Video Input mode
- ← Audio input mode
- ← Picture Size mode

VIDEO

VIDEO<S>
 NTSC
 AUDIO : 3
 SCREEN SIZE : NORMAL

- ← Video Input mode
- ← Input Signal Color System mode
- ← Audio input mode
- ← Picture Size mode

PIP or POP

Main:RGB2

Sub:VIDEO<S>

RGB2
 1024 x 768
 48kHz 60Hz
 AUDIO : 1
 VIDEO<S>
 NTSC
 SCREEN SIZE : FULL

- ← Main picture Information
- ← Sub picture Information
- ← Main picture Information

OSM (On-Screen Manager) Controls –Computer

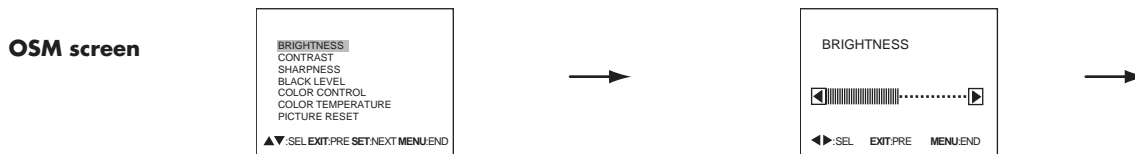
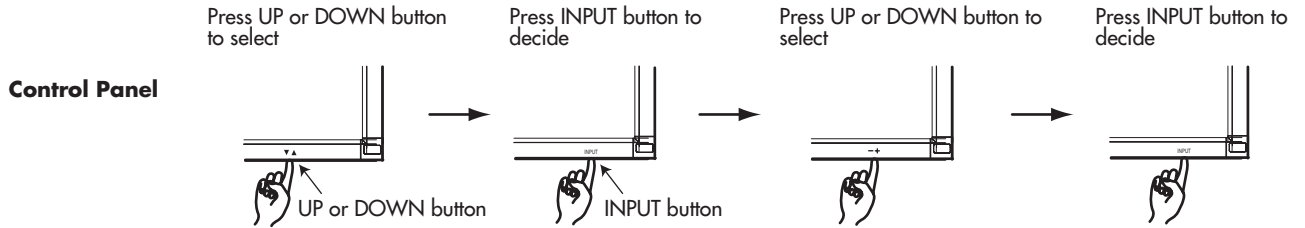
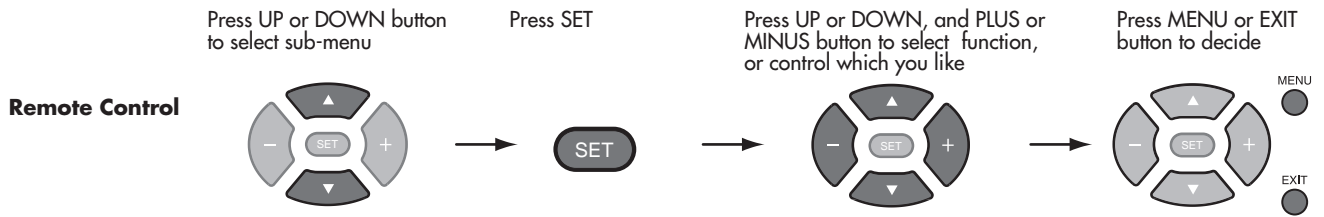

Main-Menu		Sub-Menu	
PICTURE			
BRIGHTNESS			<p>Adjusts the overall image and background screen brightness.</p> <p>Press + button to increase brightness. Press - button to decrease brightness.</p>
CONTRAST *:INPUT RGB2/3 only			<p>Adjusts the image brightness in relation to the background</p> <p>Press + button to increase contrast. Press - button to decrease contrast.</p>
SHARPNESS *:INPUT RGB2/3 only			<p>This function is digitally capable to keep crisp image at any timings. It is adjustable to get a distinct image or a soft one as you prefer and set independently for each timing.</p> <p>Press + button to increase sharpness. Press - button to decrease sharpness.</p>
BLACK LEVEL *:INPUT RGB2/3 only			<p>Press + button to increase black level. Press - button to decrease black level.</p>
COLOR CONTROL			<p>Six color presets select the desired color setting. Color temperature increases or decreases, in each preset. R, Y, G, C, B, M, S: Increases or decreases Red, Yellow, Green, Cyan, Blue Magenta and Saturation depending upon which is selected. The change in color will appear on screen and the direction (increase or decrease) will be shown by the color bars.</p>

OSM Controls –Computer continued

<p>COLOR TEMPERATURE</p>	<pre> BRIGHTNESS CONTRAST SHARPNESS BLACK LEVEL COLOR CONTROL COLOR TEMPERATURE PICTURE RESET </pre> <p>▲▼:SEL EXIT:PRE SET:NEXT MENU:END</p>	<pre> COLOR TEMPERATURE L H ----- ◀▶:SEL EXIT:PRE MENU:END </pre>	<p>To adjust the color temperature of entire screen. Adjusting lower color temperature make the screen reddish and adjusting higher color temperature make the screen bluish.</p>
<p>PICTURE RESET</p>	<pre> BRIGHTNESS CONTRAST SHARPNESS BLACK LEVEL COLOR CONTROL COLOR TEMPERATURE PICTURE RESET </pre> <p>▲▼:SEL EXIT:PRE SET:NEXT MENU:END</p>	<pre> PICTURE RESET NO YES </pre> <p>◀▶:SEL EXIT:PRE MENU:END</p>	<p>Selecting Picture Reset allows you to reset all OSM setting about PICTURE setting.</p> <p>Select "Yes" and press "SET" button to decide to restore to factory preset.</p>

<p>Main-Menu</p> <p>SCREEN</p>		<pre> PICTURE SCREEN AUDIO PICTURE IN PICTURE CONFIGURATION 1 CONFIGURATION 2 </pre> <p>▲▼:SEL EXIT:PRE SET:NEXT MENU:END</p>	
<p>Sub-Menu</p>			
<p>H POSITION</p>	<pre> H POSITION V POSITION CLOCK CLOCK PHASE H RESOLUTION V RESOLUTION SCREEN RESET </pre> <p>▲▼:SEL EXIT:PRE SET:NEXT MENU:END</p>	<pre> H POSITION - 50 + ----- ◀▶:SEL EXIT:PRE MENU:END </pre>	<p>Controls Horizontal Image position within the display area of the LCD.</p> <p>Press + button to move screen to right. Press - button to move screen to left.</p>
<p>V POSITION</p>	<pre> H POSITION V POSITION CLOCK CLOCK PHASE H RESOLUTION V RESOLUTION SCREEN RESET </pre> <p>▲▼:SEL EXIT:PRE SET:NEXT MENU:END</p>	<pre> V POSITION - 50 + ----- ◀▶:SEL EXIT:PRE MENU:END </pre>	<p>Controls Vertical Image position within the display area of the LCD.</p> <p>Press + button to move screen to UP. Press - button to move screen to DOWN.</p>
<p>CLOCK</p> <p>*:INPUT RGB2/3 only</p>	<pre> H POSITION V POSITION CLOCK CLOCK PHASE H RESOLUTION V RESOLUTION SCREEN RESET </pre> <p>▲▼:SEL EXIT:PRE SET:NEXT MENU:END</p>	<pre> CLOCK - + ----- ◀▶:SEL EXIT:PRE MENU:END </pre>	<p>Press + button to expand the width of the image on the screen the right. Press - button to narrow the width of the image on the screen the left.</p>
<p>CLOCK PHASE</p> <p>*:INPUT RGB2/3 only</p>	<pre> H POSITION V POSITION CLOCK CLOCK PHASE H RESOLUTION V RESOLUTION SCREEN RESET </pre> <p>▲▼:SEL EXIT:PRE SET:NEXT MENU:END</p>	<pre> CLOCK PHASE - + ----- ◀▶:SEL EXIT:PRE MENU:END </pre>	<p>To change the snow noise of the image.</p>
<p>H RESOLUTION</p>	<pre> H POSITION V POSITION CLOCK CLOCK PHASE H RESOLUTION V RESOLUTION SCREEN RESET </pre> <p>▲▼:SEL EXIT:PRE SET:NEXT MENU:END</p>	<pre> H RESOLUTION - 1024 + ----- ◀▶:SEL EXIT:PRE MENU:END </pre>	<p>Adjusts the horizontal size by increasing or decreasing the setting. Press + button to expand the width of the image on the screen. Press - button to narrow the width of the image on the screen.</p>
<p>V RESOLUTION</p>	<pre> H POSITION V POSITION CLOCK CLOCK PHASE H RESOLUTION V RESOLUTION SCREEN RESET </pre> <p>▲▼:SEL EXIT:PRE SET:NEXT MENU:END</p>	<pre> V RESOLUTION - 768 + ----- ◀▶:SEL EXIT:PRE MENU:END </pre>	<p>Adjusts the vertical size by increasing or decreasing the setting. Press + button to expand the height of the image on the screen. Press - button to narrow the height of the image on the screen.</p>
<p>SCREEN RESET</p>	<pre> H POSITION V POSITION CLOCK CLOCK PHASE H RESOLUTION V RESOLUTION SCREEN RESET </pre> <p>▲▼:SEL EXIT:PRE SET:NEXT MENU:END</p>	<pre> SCREEN RESET NO YES </pre> <p>◀▶:SEL EXIT:PRE MENU:END</p>	<p>Selecting Picture reset allow you to reset all OSM settings from SCREEN setting.</p> <p>Select "Yes" and press "SET" button to decide to restore to factory preset.</p>

OSM Controls –Computer continued

Main-Menu		AUDIO		PICTURE SCREEN AUDIO PICTURE IN PICTURE CONFIGURATION 1 CONFIGURATION 2 ▲▼:SEL EXIT:PRE SET:NEXT MENU:END
Sub-Menu				
TREBLE	TREBLE BASS AUDIO RESET ▲▼:SEL EXIT:PRE SET:NEXT MENU:END	TREBLE - + ◀▶:SEL EXIT:PRE MENU:END	To accentuate or control the high frequency sound. Press + button to increase TREBLE sound. Press - button to decrease TREBLE sound.	
BASS	TREBLE BASS AUDIO RESET ▲▼:SEL EXIT:PRE SET:NEXT MENU:END	BASS - + ◀▶:SEL EXIT:PRE MENU:END	To accentuate or control the low frequency sound. Press + button to increase BASS sound. Press - button to decrease BASS sound.	
AUDIO RESET	TREBLE BASS AUDIO RESET ▲▼:SEL EXIT:PRE SET:NEXT MENU:END	AUDIO RESET NO YES ◀▶:SEL EXIT:PRE MENU:END	Selecting Picture reset allows you to reset all OSM settings from AUDIO setting. Select "Yes" and press "SET" button to decide to restore to factory preset.	









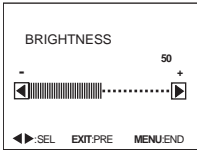

Main-Menu		PICTURE IN PICTURE		PICTURE SCREEN AUDIO PICTURE IN PICTURE CONFIGURATION 1 CONFIGURATION 2 ▲▼:SEL EXIT:PRE SET:NEXT MENU:END
Sub-Menu				
PIP SIZE	PIP SIZE PIP AUDIO PIP RESET ▲▼:SEL EXIT:PRE SET:NEXT MENU:END	PIP SIZE LARGE MIDDLE SMALL REMOTE-PIP ◀▶:SEL EXIT:PRE MENU:END	Selecting the size of picture inserted at the 'Picture-in Picture' (PIP) mode. 'Large', 'Middle', 'Small' and 'REMOTE-PIP' are available.	
PIP AUDIO	PIP SIZE PIP AUDIO PIP RESET ▲▼:SEL EXIT:PRE SET:NEXT MENU:END	PIP AUDIO MAIN AUDIO PIP AUDIO ◀▶:SEL EXIT:PRE MENU:END	Selecting the sound source at the PIP mode. When selecting 'MAIN AUDIO', you will get the sound for the main picture and when selecting 'PIP AUDIO', you will get the sound for the picture inserted.	
PIP RESET	PIP SIZE PIP AUDIO PIP RESET ▲▼:SEL EXIT:PRE SET:NEXT MENU:END	PIP RESET NO YES ◀▶:SEL EXIT:PRE MENU:END	Selecting Picture Reset allows you to reset all OSM settings from PIP setting. Select 'Yes' and press 'SET' button to decide to restore to factory preset.	

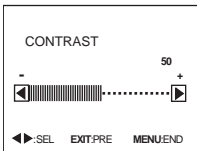

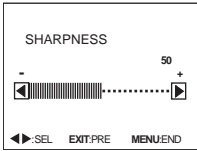

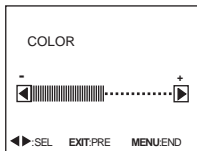
Main-Menu		CONFIGURATION 1		PICTURE SCREEN AUDIO PICTURE IN PICTURE CONFIGURATION 1 CONFIGURATION 2 ▲▼:SEL EXIT:PRE SET:NEXT MENU:END
Sub-Menu				
AUTO SETUP *:INPUT RGB2/3 only	AUTO SETUP AUTO ADJUST AUTO BRIGHTNESS POWER SAVE LANGUAGE OSM TIME OFF TIMER SCREEN SAVER FACTORY PRESET ▲▼:SEL EXIT:PRE SET:NEXT MENU:END	AUTO SETUP NO YES ◀▶:SEL EXIT:PRE MENU:END	Select 'Yes' and press 'SET' button to automatically adjust horizontal position, vertical position, clock, clock-phase, black level.	
AUTO ADJUST *:INPUT RGB2/3 only	AUTO SETUP AUTO ADJUST AUTO BRIGHTNESS POWER SAVE LANGUAGE OSM TIME OFF TIMER SCREEN SAVER FACTORY PRESET ▲▼:SEL EXIT:PRE SET:NEXT MENU:END	AUTO ADJUST ON OFF ◀▶:SEL EXIT:PRE MENU:END	Selecting the auto adjust ON/OFF. When selecting ON, the clock-phase will adjust automatically.	

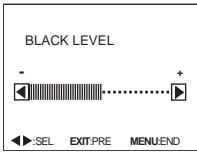
OSM Controls –Computer continued

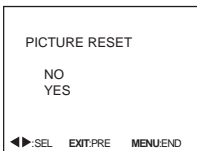

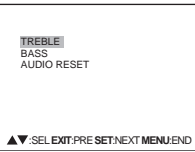
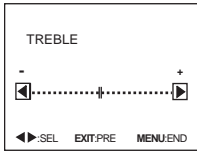

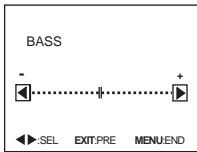
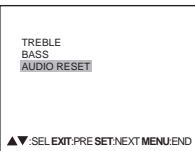



<p>AUTO BRIGHTNESS</p> <p>*:INPUT RGB2/3 only</p>	<pre>AUTO SETUP AUTO ADJUST AUTO BRIGHTNESS POWER SAVE LANGUAGE OSM TIME OFF TIMER SCREEN SAVER FACTORY PRESET ▲▼:SEL EXIT:PRE SET:NEXT MENU:END</pre>	<pre>AUTO BRIGHTNESS ON OFF ◀▶:SEL EXIT:PRE MENU:END</pre>	<p>Selecting the Auto Brightness ON/OFF. When selecting 'ON', the Brightness will adjust automatically.</p>
<p>POWER SAVE</p>	<pre>AUTO SETUP AUTO ADJUST AUTO BRIGHTNESS POWER SAVE LANGUAGE OSM TIME OFF TIMER SCREEN SAVER FACTORY PRESET ▲▼:SEL EXIT:PRE SET:NEXT MENU:END</pre>	<pre>POWER SAVE ON OFF ◀▶:SEL EXIT:PRE MENU:END</pre>	<p>Selecting the power management ON/OFF mode.</p>
<p>LANGUAGE</p>	<pre>AUTO SETUP AUTO ADJUST AUTO BRIGHTNESS POWER SAVE LANGUAGE OSM TIME OFF TIMER SCREEN SAVER FACTORY PRESET ▲▼:SEL EXIT:PRE SET:NEXT MENU:END</pre>	<pre>LANGUAGE ENGLISH DEUTSCH ESPAÑOL FRANÇAIS ITALIANO SVENSKA JAPAN ◀▶:SEL EXIT:PRE MENU:END</pre>	<p>OSM control menus are available in seven languages.</p>
<p>OSM TIME</p>	<pre>AUTO SETUP AUTO ADJUST AUTO BRIGHTNESS POWER SAVE LANGUAGE OSM TIME OFF TIMER SCREEN SAVER FACTORY PRESET ▲▼:SEL EXIT:PRE SET:NEXT MENU:END</pre>	<pre>OSM TIME 5 - + ----- ----- ----- ----- ◀▶:SEL EXIT:PRE MENU:END</pre>	<p>In the OSM Time menu, you can select how long the OSM information appears, when pressing the Display key. Time from 3 to 30 seconds is available.</p>
<p>OFF TIMER</p>	<pre>AUTO SETUP AUTO ADJUST AUTO BRIGHTNESS POWER SAVE LANGUAGE OSM TIME OFF TIMER SCREEN SAVER FACTORY PRESET ▲▼:SEL EXIT:PRE SET:NEXT MENU:END</pre>	<pre>OFF TIMER ON 24H OFF ◀▶:SEL EXIT:PRE MENU:END</pre>	<p>In the OFF TIMER menu, you can preset the monitor to automatically power down. A time between 1 to 24 hours is available.</p>
<p>SCREEN SAVER</p>	<pre>AUTO SETUP AUTO ADJUST AUTO BRIGHTNESS POWER SAVE LANGUAGE OSM TIME OFF TIMER SCREEN SAVER FACTORY PRESET ▲▼:SEL EXIT:PRE SET:NEXT MENU:END</pre>	<pre>SCREEN SAVER ON OFF ◀▶:SEL EXIT:PRE MENU:END</pre>	<p>To select SCREEN SAVER mode, select ON/OFF</p>
<p>FACTORY PRESET</p>	<pre>AUTO SETUP AUTO ADJUST AUTO BRIGHTNESS POWER SAVE LANGUAGE OSM TIME OFF TIMER SCREEN SAVER FACTORY PRESET ▲▼:SEL EXIT:PRE SET:NEXT MENU:END</pre>	<pre>FACTORY PRESET NO YES ◀▶:SEL EXIT:PRE MENU:END</pre>	<p>Selecting YES allows you to reset all OSM control settings back to the factory settings.</p>
<p>Main-Menu</p>			
<p>CONFIGURATION 2</p>		<pre>PICTURE SCREEN AUDIO PICTURE IN PICTURE CONFIGURATION 1 CONFIGURATION 2 ▲▼:SEL EXIT:PRE SET:NEXT MENU:END</pre>	
<p>Sub-Menu</p>			
<p>LONG CABLE ON/OFF</p> <p>*:INPUT RGB2/3 only</p>	<pre>LONG CABLE ON/OFF LONG CABLE MANUAL ▲▼:SEL EXIT:PRE SET:NEXT MENU:END</pre>	<pre>LONG CABLE ON OFF ◀▶:SEL EXIT:PRE MENU:END</pre>	<p>A set up ON/OFF of long cable alteration can be performed. In ON, enforcement of an AUTO Set Up performed alteration. Please refer to the CD-ROM included for alteration.</p>
<p>LONG CABLE MANUAL</p> <p>*:INPUT RGB2/3 only</p>	<pre>LONG CABLE ON/OFF LONG CABLE MANUAL ▲▼:SEL EXIT:PRE SET:NEXT MENU:END</pre>	<pre>LONG CABLE MANUAL R DELAY 0 G DELAY 0 B DELAY 0 R SHARPNESS 0 G SHARPNESS 0 B SHARPNESS 0 SOG PEAK 0 ◀▶:SEL EXIT:PRE MENU:END</pre>	<p>Degradation of the quality of image which happens by using a long cable is adjusted the optimal.</p>

OSM Controls –DVD & HD

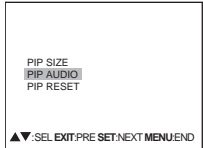

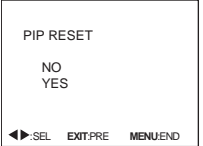

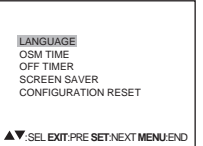

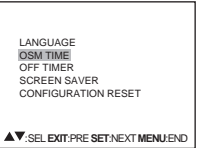
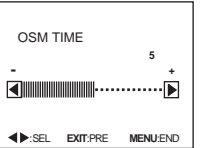
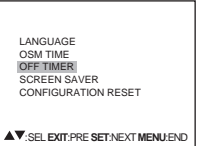
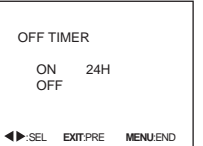
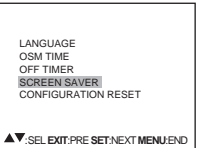
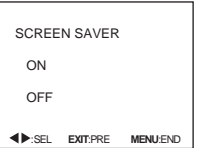
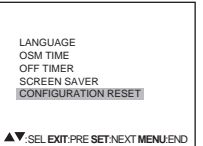
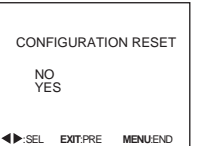







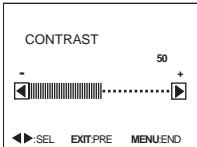

Main-Menu		PICTURE	
Sub-Menu			
BRIGHTNESS			<p>Adjusts the overall image and background screen brightness.</p> <p>Press + button to increase sharpness. Press - button to decrease sharpness.</p>
CONTRAST			<p>Adjusts the image brightness in relation to the back ground</p> <p>Press + button to increase contrast. Press - button to decrease contrast.</p>
SHARPNESS			<p>This function is digitally capable to keep crisp image at any timings. It is adjustable to get a distinct image or a soft one as you prefer and set independently for each timing.</p> <p>Press + button to increase sharpness. Press - button to decrease sharpness.</p>
COLOR			<p>Adjust the color depth of the screen.</p> <p>Press + button to increase color depth. Press - button to decrease color depth.</p>
BLACK LEVEL			<p>Press + button to increase black level. Press - button to decrease black level.</p>
PICTURE RESET			<p>Selecting Picture Reset allows you to reset all OSM settings from color.</p> <p>Select "Yes" and press "SET" button to restore to factory preset.</p>

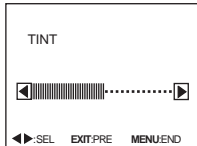
Main-Menu		AUDIO	
Sub-Menu			
TREBLE			<p>To accentuate or quiet the high frequency sound.</p> <p>Press + button to increase TREBLE sound. Press - button to decrease TREBLE sound.</p>
BASS			<p>To accentuate or quiet the low frequency sound.</p> <p>Press + button to increase BASS sound. Press - button to decrease BASS sound.</p>
AUDIO RESET			<p>Selecting Picture Reset allow you to reset all OSM settings from AUDIO setting.</p> <p>Select "Yes" and press "SET" button to restore factory preset.</p>

OSM Controls –DVD & HD continued



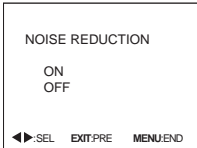
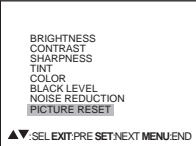



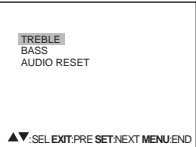
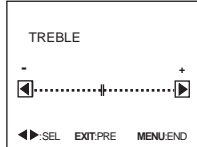



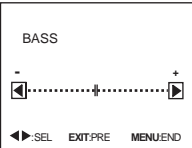
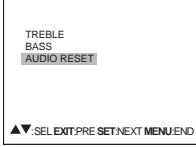

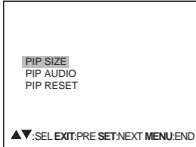
Main-Menu		PICTURE IN PICTURE	
Sub-Menu			
			
PIP SIZE			<p>Selecting the size of picture inserted at the 'Picture-in Picture' (PIP) mode. 'Large', 'Middle', and 'Small' are available.</p>
PIP AUDIO			<p>Selecting the sound source at the PIP mode. When selecting 'MAIN AUDIO', you get the sound for the main picture and when selecting 'PIP AUDIO', you get the sound for the picture inserted.</p>
PIP RESET			<p>Selecting Picture Reset allows you to reset all OSM settings from PIP setting.</p> <p>Select 'Yes' and press the 'SET' button to restore the factory preset.</p>
Main-Menu		CONFIGURATION	
Sub-Menu			
			
LANGUAGE			<p>OSM control menus are available in seven languages.</p>
OSM TIME			<p>In the OSM Time menu, you can select how long the OSM information disappear after Display key push. A time between 3 to 30 seconds, are available.</p>
OFF TIMER			<p>To select OFF TIMER mode ON/OFF.</p> <p>In the OFF TIMER menu, you can preset the monitor to automatically power down. A time between 1 to 24 hours is available.</p>
SCREEN SAVER			<p>To select SCREEN SAVER mode, select ON/OFF</p>
CONFIGURATION RESET			<p>Selecting the configuration reset allow you to reset all configuration settings.</p> <p>Select 'Yes' and press 'SET' button to decide to restore to factory preset.</p>

OSM Controls –AV Input

Main-Menu			
PICTURE			
Sub-Menu			
BRIGHTNESS			<p>Adjusts the overall image and background screen brightness.</p> <p>Press + button to increase brightness. Press - button to decrease brightness.</p>
CONTRAST			<p>Adjusts the image brightness in relation to the background</p> <p>Press + button to increase contrast. Press - button to decrease contrast.</p>
SHARPNESS			<p>This function is digitally capable to keep crisp image at any timings. It is continuously adjustable to get distinct image or soft one as you prefer and set independently by different timing.</p> <p>Press + button to increase sharpness. Press - button to decrease sharpness.</p>
TINT			<p>Adjust the tint of the screen.</p> <p>Press + button the flesh tone color becomes greenish. Press - button the flesh tone color becomes purplish.</p>
COLOR			<p>Adjust the color depth of the screen.</p> <p>Press + button to increase color depth. Press - button to decrease color depth.</p>
BLACK LEVEL			<p>Press + button to increase black level. Press - button to decrease black level.</p>
NOISE REDUCTION			<p>Activates Auto Noise reduction function.</p>
PICTURE RESET			<p>Selecting Picture reset allows you to reset all OSM settings from picture setting.</p> <p>Select "Yes" and press "SET" button to decide to restore to factory preset.</p>

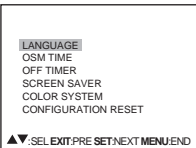
Main-Menu			
AUDIO			
Sub-Menu			
TREBLE			<p>To accentuate or control the high frequency sound.</p> <p>Press + button to increase TREBLE sound. Press - button to decrease TREBLE sound.</p>

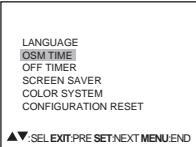
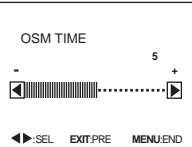
OSM Controls –AV Input continued

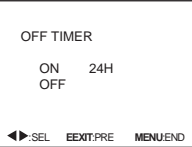
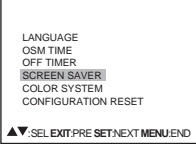
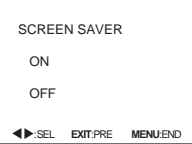
<p>BASS</p>			<p>To accentuate or control the low frequency sound.</p> <p>Press + button to increase BASS sound. Press - button to decrease BASS sound.</p>
<p>AUDIO RESET</p>			<p>Selecting Picture Reset allows you to reset all OSM settings from AUDIO setting.</p> <p>Select "Yes" and press "SET" button to decide to restore to factory preset.</p>
<p>Main-Menu</p> <p>PICTURE IN PICTURE</p> <p>Sub-Menu</p>			
<p>PIP SIZE</p>			<p>Selecting the size of picture inserted at the 'Picture-in Picture' (PIP) mode.</p> <p>'Large', 'Middle', and 'Small' are available.</p>
<p>PIP AUDIO</p>			<p>Selecting the sound source at the PIP mode.</p> <p>When selecting 'MAIN AUDIO', you get the sound for the main picture and when selecting 'PIP AUDIO', you get the sound for the picture inserted.</p>
<p>PIP RESET</p>			<p>Selecting Picture reset allow you to reset all OSM setting about PIP setting.</p> <p>Select 'Yes' and press 'SET' button to decide to restore to factory preset.</p>
<p>Main-Menu</p> <p>CONFIGURATION</p> <p>Sub-Menu</p>			
<p>LANGUAGE</p>			<p>OSM control menus are available in seven languages.</p>
<p>OSM TIME</p>			<p>In the OSM Time menu, you can select how long the OSM information disappear after Display key push.</p> <p>A time between 3 to 30 seconds is available.</p>
<p>OFF TIMER</p>			<p>To select OFF TIMER mode ON/OFF.</p> <p>In the OFF TIMER menu, you can select how long monitor auto turn off time after monitor turn on.</p> <p>A time between 1 to 24 hours is available.</p>
<p>SCREEN SAVER</p>			<p>To select SCREEN SAVER mode, select ON/OFF</p>

OSM Controls –AV Input continued

<p>COLOR SYSTEM</p>	<pre> LANGUAGE OSM TIME OFF TIMER SCREEN SAVER COLOR SYSTEM CONFIGURATION RESET </pre> <p>▲▼.SEL EXIT:PRE SET:NEXT MENU:END</p>	<pre> COLOR SYSTEM PAL SECAM </pre> <p>◀▶.SEL EXIT:PRE MENU:END</p>	<p>Selecting the Color System depends on your input video format.</p> <p>NTSC is automatic.</p>
<p>CONFIGURATION RESET</p>	<pre> LANGUAGE OSM TIME OFF TIMER SCREEN SAVER COLOR SYSTEM CONFIGURATION RESET </pre> <p>▲▼.SEL EXIT:PRE SET:NEXT MENU:END</p>	<pre> CONFIGURATION RESET NO YES </pre> <p>◀▶.SEL EXIT:PRE MENU:END</p>	<p>Selecting the Configuration Reset allows you to reset all configuration settings.</p> <p>Select 'Yes' and press 'SET' button to decide to restore to factory preset.</p>

Using the LCD with a Personal Computer (PC)

This LCD monitor can be controlled by connecting a personal computer with a RS-232C terminal.

Functions that can be controlled by a personal computer are:

- Power ON or OFF
- Switching between input signals

Connection

LCD Monitor + PC

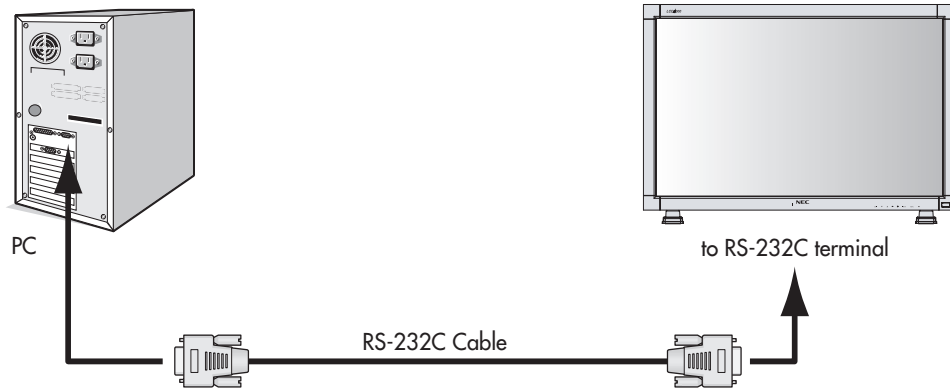

Note: If your PC (IBM or IBM compatible) is equipped only with a 25-pin serial port connector, a 25-pin serial port adapter is required. Contact your dealer for details.

1) Interface

PROTOCOL	RS-232C
BAUD RATE	9600 [bps]
DATA LENGTH	8 [bits]
PARITY BIT	NONE
STOP BIT	1 [bits]
FLOW CONTROL	NONE

This LCD monitor uses RXD, TXD and GND lines for RS-232C control.

For RS-232C cable, the reverse type cable should be used.

2) Control command diagram

The command is structured by the address code, function code, data code and end code. The length of the command is different for each function.

	Address code	Function code	Data code	End code
HEX	30h 30h	Function	Data	0Dh
ASCII	'0' '0'	Function	Data	↵

[Address code] 30h 30h (In ASCII code, '0' '0') fixed.

[Function code] A code of each fixed control move.

[Data code] A code of each fixed control data (number) and not always indicated.

[End code] 0Dh (In ASCII code, '↵') fixed.

Using the LCD with a Personal Computer *-continued*

3) Control sequence

- (1) The command from a personal computer to the LCD monitor will be sent in 400ms.
- (2) The LCD monitor will send a return command 400ms* after it has received an encode. If the command isn't received correctly, the LCD monitor will not send the return command.
- (3) The personal computer checks the command and confirms if the command which has been sent has been executed or not.
- (4) This LCD monitor sends various codes other than return code. When having a control sequence by RS-232C, reject other codes from personal computers side.

*: The sending time of return command may delay depending on the condition (during changing of the input signal, etc.).

[Example] Turn the power ON (' ' is for ASCII code)

Sending commands from the PC etc.	Status code from LCD monitor	Meaning
30 30 21 0D '0' '0' '!' '↵'		Command for POWER ON
	30 30 21 0D '0' '0' '!' '↵'	Command received (Command echo back)

4) Operation commands

The operation commands execute the basic operation setting of this LCD monitor.
It may not operate when changing the signal:

Operation	ASCII	HEX
POWER ON	!	21h
POWER OFF	"	22h
INPUT RGB 1	_r1	5Fh 72h 31h
INPUT RGB 2	_r2	5Fh 72h 32h
INPUT RGB 3	_r3	5Fh 72h 33h
INPUT VIDEO	_v1	5Fh 76h 31h
INPUT DVD/HD	_v2	5Fh 76h 32h

- POWER OFF command will not work for 1 minute after the power is turned on.
- POWER ON command will not work for 1 minute after the power is turned off.

Features

40" diagonal screen size adds a new option to information display visual offerings.

1280 x 768 resolution allows for crisp text and precise images.

No permanent phosphor image burn-in contributes to optimal screen performance and longer monitor life.

XtraView® technology allows for wide-angle viewing.

DDC/CI capabilities allow control commands to be sent directly to the monitor through a standard PC or over an existing network by a system administrator.

CableComp™ automatic long cable compensation prevents image quality degradation caused by long cable lengths.

User-friendly, efficient design features the currently proposed VESA-standard mounting and an overall lightweight construction for easy transport and installation.

Optional detachable speakers deliver an enhanced multimedia experience with amazing sound quality.

Low power consumption and reduced heat emission lead to a lower total cost of ownership.

On Screen Manager (OSM®) puts you in complete control of display setting adjustments.

NEC's quality and reliability provide peace of mind with a 1-year warranty (including backlight) and 24/7 customer service and technical support.

No Touch Auto Adjust: No Touch Auto Adjust automatically adjusts the monitor to optimal settings upon initial setup.

Reduced Footprint: Provides the ideal solution for environments requiring superior image quality but with size and weight limitations. The monitor's small footprint and low weight allow it to be moved or transported easily from one location to another.

AccuColor® Control System with sRGB allows you to change between the color settings on your display to match your personal preference.

Plug and Play: The Microsoft® solution with the Windows®95/98/ME/2000/XP operating system facilitates setup and installation by allowing the monitor to send its capabilities (such as screen size and resolutions supported) directly to your computer, automatically optimizing display performance.

Intelligent Power Manager (IPM™) System provides innovative power-saving methods, saving two-thirds of your monitor energy costs.

Multiple Frequency Technology automatically adjusts monitor to the display card's scanning frequency, thus displaying the resolution required.

FullScan® Capability allows you to use the entire screen area in most resolutions, significantly expanding image size.

VESA Standard Mounting Interface allows users to connect their LCD monitor to any VESA standard third party mounting arm or bracket. Allows for the monitor to be mounted on a wall or an arm using any third party compliant device. NEC recommends using mounting interface that comply with UL1678 standard in North America.

DVI-D: The digital-only subset of DVI created by the Digital Display Working Group (DDWG) for digital connections between computers and displays. As a digital-only connector, analog support is not provided off a DVI-D connector. As a DVI-based digital only connection, only a simple adapter is necessary for compatibility between DVI-D and other DVI-based digital connectors such as DFP and P&D.

OSM Display Screen Copyright 2002 by NEC-Mitsubishi Electronics Display of America, Inc.

Troubleshooting

No picture

- The signal cable should be completely connected to the display card/computer.
- The display card should be completely seated in its slot.
- Front Power Switch and computer power switch should be in the ON position.
- Check to make sure that a supported mode has been selected on the display card or system being used. (Please consult display card or system manual to change graphics mode.)
- Check the monitor and your display card with respect to compatibility and recommended settings.
- Check the signal cable connector for bent or pushed-in pins.

Power Button does not respond

- Unplug the power cord of the monitor from the AC outlet to turn off and reset the monitor.

Image persistence

- Image persistence is when a residual or "ghost" image of a previous image remains visible on the screen. Unlike CRT monitors, LCD monitors image persistence is not permanent, but constant images being displayed for a long period of time should be avoided. To alleviate image persistence, turn off the monitor for as long as the previous image was displayed. For example, if an image was on the monitor for one hour and a residual image remains, the monitor should be turned off for one hour to erase the image.

NOTE: As with all personal display devices, NEC-Mitsubishi Electronics Display recommends using a moving screen saver at regular intervals whenever the screen is idle or turning off the monitor when not in use.

Image is unstable, unfocused or swimming is apparent

- Signal cable should be completely attached to the computer.
- Use the OSM screen controls to focus and adjust display by increasing or decreasing the clock phase total. When the display mode is changed, the OSM Image Adjust settings may need to be readjusted.
- Check the monitor and your display card with respect to compatibility and recommended signal timings.
- If your text is garbled, change the video mode to non-interlace and use 60Hz refresh rate.

Image of component signal is greenish

- Check to see if the DVD/HD input connector is selected.

LED on monitor is not lit (no green or red color can be seen)

- Power Switch should be in the ON position and power cord should be connected.
- Make certain the computer is not in a power-saving mode (touch the keyboard or mouse).

Display image is not sized properly

- Use the OSM screen controls to increase or decrease the clock total.
- Check to make sure that a supported mode has been selected on the display card or system being used. (Please consult display card or system manual to change graphics mode.)

Selected resolution is not displayed properly

- Use OSM information to enter Information menu and confirm that the appropriate resolution has been selected. If not, select corresponding option.

No Sound

- Check to see if speaker cable is properly connected.
- Check to see if mute is activated.
- Check to see if volume is set at minimum.

Remote Control is not available

- Test the Remote Control's batteries for strength/life.
- Check if the batteries are inserted correctly.
- Check if the Remote Control is pointed at the monitor's remote sensor.

Light vertical or horizontal stripes may appear depending on different display patterns.

References

NEC-Mitsubishi Monitor Customer Service & Support

Customer Service and Technical Support:	(800) 632-4662
Fax:	(800) 695-3044
Parts and Accessories/Macintosh Cable Adapter:	(888) NEC-MITS [888-632-6487]
Customer Service Policies & Processes:	http://www.necmitsubishi.com/css/ServicePolicies/ServicePolicies.htm
Online Technical Support Knowledge Base:	http://www.necmitsubishi.com/css/knowledgebase.cfm
Customer Service & Technical Support Email:	http://www.necmitsubishi.com/css/techform.htm

Sales and Product Information

Sales Information Line	(888) NEC-MITS [888-632-6487]
Canadian Customers	(866) 771-0266, Ext#: 4037
Government Sales	(800) 284-6320
Government Sales	email: gov@necmitsubishi.com

Rebate Status Information

NEC Rebate Status	www.rebatesHQ.com or 866-765-5696
Mitsubishi Rebate Status	www.rebatesHQ.com or 877-405-4692

Electronic Channels

World Wide Web:	http://www.necmitsubishi.com
Product Registration:	http://www.necmitsubishi.com/productregistration
European Operations:	http://www.nec-mitsubishi.com

Windows® 95/98/Me/2000/XP INF File:

<http://www.necmitsubishi.com> and select "Drivers and Downloads"

Specifications

LCD Module	Analog Input		Digital Input
	(40" / 101.6cm diagonal)		
	Pixel Pitch	0.681mm	
	Resolution	1280 x 768 dots (WXGA)	
	Color	Over 16 million colors	
	Brightness	450cd/m2 (Typ.)	
Viewing Angle	Up 85 / Down 85 / Left 85 / Right 85 (typ) @ CR >10		
External speaker output impedance		Rating 7W x 7W (8 Ohm)	
Frequency	Horizontal	31.5kHz - 75.0kHz (15.75kHz)	31.5kHz - 48.4kHz
	Vertical	58.0 - 62.0 Hz	58.0 - 62.0 Hz
Pixel Clock		25.0MHz - 162.0MHz	25.0MHz - 65.0MHz
Viewable Size		871.68 x 523.008mm	
Input Signal	PC Input		
	Video	Analog RGB 0.7V p-p	TMDS
		Input Impedance 75 Ohm Composite : TTL level (Positive / Negative) Composite sync on Green Video : 0.3Vp-p Nega (video 0.7Vp-p Positive)	
	Sync	Separate : TTL level (Positive / Negative), Input Impedance 2.2k Ohm	
	Input terminal	BNC (R,G,B,H,V)	DVI-D (Digital)
	Signal cable	1.5pin Mini D-sub	
	VIDEO Input	Composite 1.0V p-p Input Impedance 75 Ohm BNC and RCA-INPUT Y/C Y:0.7V p-p C:0.283V p-p Input Impedance 75 Ohm S-TERMINAL-INPUT Component 1.0/0.7V p-p Input Impedance 75 Ohm BNC-INPUT	
	AUDIO Input	RCA PIN-JACK L/R 2INPUT, STEREO Mini Jack 1INPUT	
	Control Input	9 Pin Mini D-sub (RS-232C)	
Power Supply		2.5A @ 100-120V, 1.1A @ 220V-240V	
Operational Environment	Temperature	5 - 40 deg C	
	Humidity	10 - 80% (without condensation)	
Storage Environment	Temperature	-20 - 60 deg C	
	Humidity	10 - 90% (without condensation) / below 60% over 40 deg C	
Dimension	Net	949 (W) x 605 (H) x 141 (D) mm (without Stand), 949 (W) x 643.9 (H) x 306 (D) mm (with Stand)	
	Gross	1125 (W) x 770 (H) x 261 (D) mm	
Weight	Net	69.4 lbs / 27.5kg	
	Gross	82.7 lbs / 33.5kg	
VESA compatible arm mounting interface		3 x 200mm x 100mm (8 Holes)	
		2 x 200mm x 100mm (6 Holes)	
Complied Regulatory and Guidelines		UL 1950/CSA C22.2 No.950/ TUV-GS/EN60950 FCC-B/DOC-B/EN55022-A/EN55024/EN61000-3-2/EN61000-3-3/CE	
Power Management		VESA DPMS	
Plug & Play		VESA DDC2Bi, DDCCI	
Resolutions Supported		640 x 480 at 60 Hz 800 x 600 at 60 Hz 1024 x 768 at 60 Hz 1280 x 768 at 60 Hz NEC-Mitsubishi Electronics Display cites recommended resolution NTSC / PAL HDTV: 480i, 480p, 720p, 1080i	
Accessories		User's manual, Power Cord, Video Signal Cable, Remote Control, AA Battery x 2, Clamper x 2, Screw x 2, CD-ROM Ferrite Core x 2, Stand for the Independence x 2, Screw (M5 x 40) for stand x 4, Band	

Limited Warranty

NEC-Mitsubishi Electronics Display of America, Inc. (hereinafter "NMD-A") warrants this Product to be free from defects in material and workmanship and, subject to the conditions set forth below, agrees to repair or replace (at NMD-A's sole option) any part of the enclosed unit which proves defective for a period of one (1) year from the date of first consumer purchase. Spare parts are warranted for ninety (90) days. Replacement parts or unit may be new or refurbished and will meet specifications of the original parts or unit.

This warranty gives you specific legal rights and you may also have other rights, which vary from state to state. This warranty is limited to the original purchaser of the Product and is not transferable. This warranty covers only NMD-A-supplied components. Service required as a result of third party components is not covered under this warranty. In order to be covered under this warranty, the Product must have been purchased in the U.S.A. or Canada by the original purchaser. This warranty only covers Product distribution in the U.S.A. or Canada by NMD-A. No warranty service is provided outside of the U.S.A. or Canada. Proof of Purchase will be required by NMD-A to substantiate date of purchase. Such proof of purchase must be an original bill of sale or receipt containing name and address of seller, purchaser, and the serial model number of the product.

It shall be your obligation and expense to have the Product shipped, freight prepaid, or delivered to the authorized reseller from whom it was purchased or other facility authorized by NMD-A to render the services provided hereunder in the original package. All Products returned to NMD-A for service MUST have prior approval, which may be obtained by calling 1-800-632-4662. The Product shall not have been previously altered, repaired, or serviced by anyone other than a service facility authorized by NMD-A to render such service, the serial number of the product shall not have been altered or removed. In order to be covered by this warranty the Product shall not have been subjected to displaying of fixed images for long periods of time resulting in image persistence (afterimage effects), accident, misuse or abuse or operated contrary to the instructions contained in the User's Manual. Any such conditions will void this warranty.

NMD-A SHALL NOT BE LIABLE FOR DIRECT, INDIRECT, INCIDENTAL, CONSEQUENTIAL, OR OTHER TYPES OF DAMAGES RESULTING FROM THE USE OF ANY NMD-A PRODUCT OTHER THAN THE LIABILITY STATED ABOVE. THESE WARRANTIES ARE IN LIEU OF ALL OTHER WARRANTIES EXPRESS OR IMPLIED, INCLUDING, BUT NOT LIMITED TO, THE IMPLIED WARRANTIES OF MERCHANTABILITY OR FITNESS FOR A PARTICULAR PURPOSE. SOME STATES DO NOT ALLOW THE EXCLUSION OF IMPLIED WARRANTIES OR THE LIMITATION OR EXCLUSION OF LIABILITY FOR INCIDENTAL OR CONSEQUENTIAL DAMAGES SO THE ABOVE EXCLUSIONS OR LIMITATIONS MAY NOT APPLY TO YOU.

This Product is warranted in accordance with the terms of this limited warranty. Consumers are cautioned that Product performance is affected by system configuration, software, the application, customer data, and operator control of the system, among other factors. While NMD-A Products are considered to be compatible with many systems, specific functional implementation by the customers of the Product may vary. Therefore, suitability of a Product for a specific purpose or application must be determined by consumer and is not warranted by NMD-A.

For the name of your nearest authorized NEC-Mitsubishi Electronics Display service facility, contact NEC-Mitsubishi Electronics Display of America at 1-800-632-4662.

Declaration of the Manufacturer

We hereby certify that the color monitors LCD4000 is in compliance with Council Directive 73/23/EEC:

– EN 60950

Council Directive 89/336/EEC:

— EN 55022

— EN 61000-3-2

— EN 61000-3-3

— EN 55024

and marked with



NEC-Mitsubishi Electric Visual
Systems Corporation
4-13-23, Shibaura,
Minato-Ku
Tokyo 108-0023, Japan

NEC LCD4000

PROPRIETARY NOTICE AND LIABILITY DISCLAIMER

The information disclosed in this document, including all designs and related materials, is the valuable property of NEC-Mitsubishi Electronics Display of America and/or its licensors, as appropriate, reserve all patent, copyright and other proprietary rights to this document, including all design, manufacturing, reproduction, use and sales rights thereto, except to the extent said rights are expressly granted to others.

The NEC-Mitsubishi Electronics Display of America product(s) discussed in this document are warranted in accordance with the terms of the Limited Warranty Statement accompanying each product. However, actual performance of each such product is dependent upon factors such as system configuration, customer data and operator control. Since implementation by customers of each product may vary, the suitability of specific product configurations and applications must be determined by the customer and is not warranted by NEC-Mitsubishi Electronics Display of America.

To allow for design and specification improvements, the information in this document is subject to change at any time without notice. Reproduction of this document or portions thereof without prior approval of NEC-Mitsubishi Electronics Display of America is prohibited.

DECLARATION OF CONFORMITY

This device complies with Part 15 of FCC Rules. Operation is subject to the following two conditions. (1) This device may not cause harmful interference, and (2) this device must accept any interference received, including interference that may cause undesired operation.

U.S. Responsible Party:	NEC-Mitsubishi Electronics Display of America, Inc.
Address:	1250 North Arlington Heights Road, Suite 500 Itasca, Illinois 60143-1248
Tel. No.:	(630) 467-3000

Type of Product:	Computer Monitor
Equipment Classification:	Class B Peripheral
Model:	LCD4000



We hereby declare that the equipment specified above conforms to the technical standards as specified in the FCC Rules.

Windows is a registered trademark of Microsoft Corporation. NEC is a registered trademark of NEC Corporation. All other brands and product names are trademarks or registered trademarks of their respective owners.

NEC

Free Manuals Download Website

<http://myh66.com>

<http://usermanuals.us>

<http://www.somanuals.com>

<http://www.4manuals.cc>

<http://www.manual-lib.com>

<http://www.404manual.com>

<http://www.luxmanual.com>

<http://aubethermostatmanual.com>

Golf course search by state

<http://golfingnear.com>

Email search by domain

<http://emailbydomain.com>

Auto manuals search

<http://auto.somanuals.com>

TV manuals search

<http://tv.somanuals.com>