

SCXI™

SCXI-1503 User Manual

March 2007
374271A-01



Worldwide Technical Support and Product Information

ni.com

National Instruments Corporate Headquarters

11500 North Mopac Expressway Austin, Texas 78759-3504 USA Tel: 512 683 0100

Worldwide Offices

Australia 1800 300 800, Austria 43 662 457990-0, Belgium 32 (0) 2 757 0020, Brazil 55 11 3262 3599, Canada 800 433 3488, China 86 21 5050 9800, Czech Republic 420 224 235 774, Denmark 45 45 76 26 00, Finland 385 (0) 9 725 72511, France 33 (0) 1 48 14 24 24, Germany 49 89 7413130, India 91 80 41190000, Israel 972 3 6393737, Italy 39 02 413091, Japan 81 3 5472 2970, Korea 82 02 3451 3400, Lebanon 961 (0) 1 33 28 28, Malaysia 1800 887710, Mexico 01 800 010 0793, Netherlands 31 (0) 348 433 466, New Zealand 0800 553 322, Norway 47 (0) 66 90 76 60, Poland 48 22 3390150, Portugal 351 210 311 210, Russia 7 495 783 6851, Singapore 1800 226 5886, Slovenia 386 3 425 42 00, South Africa 27 0 11 805 8197, Spain 34 91 640 0085, Sweden 46 (0) 8 587 895 00, Switzerland 41 56 2005151, Taiwan 886 02 2377 2222, Thailand 662 278 6777, Turkey 90 212 279 3031, United Kingdom 44 (0) 1635 523545

For further support information, refer to the *Technical Support Information* document. To comment on National Instruments documentation, refer to the National Instruments Web site at ni.com/info and enter the info code feedback.

© 2007 National Instruments Corporation. All rights reserved.

Important Information

Warranty

The SCXI-1503 is warranted against defects in materials and workmanship for a period of one year from the date of shipment, as evidenced by receipts or other documentation. National Instruments will, at its option, repair or replace equipment that proves to be defective during the warranty period. This warranty includes parts and labor.

The media on which you receive National Instruments software are warranted not to fail to execute programming instructions, due to defects in materials and workmanship, for a period of 90 days from date of shipment, as evidenced by receipts or other documentation. National Instruments will, at its option, repair or replace software media that do not execute programming instructions if National Instruments receives notice of such defects during the warranty period. National Instruments does not warrant that the operation of the software shall be uninterrupted or error free.

A Return Material Authorization (RMA) number must be obtained from the factory and clearly marked on the outside of the package before any equipment will be accepted for warranty work. National Instruments will pay the shipping costs of returning to the owner parts which are covered by warranty.

National Instruments believes that the information in this document is accurate. The document has been carefully reviewed for technical accuracy. In the event that technical or typographical errors exist, National Instruments reserves the right to make changes to subsequent editions of this document without prior notice to holders of this edition. The reader should consult National Instruments if errors are suspected. In no event shall National Instruments be liable for any damages arising out of or related to this document or the information contained in it.

EXCEPT AS SPECIFIED HEREIN, NATIONAL INSTRUMENTS MAKES NO WARRANTIES, EXPRESS OR IMPLIED, AND SPECIFICALLY DISCLAIMS ANY WARRANTY OF MERCHANTABILITY OR FITNESS FOR A PARTICULAR PURPOSE. CUSTOMER'S RIGHT TO RECOVER DAMAGES CAUSED BY FAULT OR NEGLIGENCE ON THE PART OF NATIONAL INSTRUMENTS SHALL BE LIMITED TO THE AMOUNT THEREOF PAID BY THE CUSTOMER. NATIONAL INSTRUMENTS WILL NOT BE LIABLE FOR DAMAGES RESULTING FROM LOSS OF DATA, PROFITS, USE OF PRODUCTS, OR INCIDENTAL OR CONSEQUENTIAL DAMAGES, EVEN IF ADVISED OF THE POSSIBILITY THEREOF. This limitation of the liability of National Instruments will apply regardless of the form of action, whether in contract or tort, including negligence. Any action against National Instruments must be brought within one year after the cause of action accrues. National Instruments shall not be liable for any delay in performance due to causes beyond its reasonable control. The warranty provided herein does not cover damages, defects, malfunctions, or service failures caused by owner's failure to follow the National Instruments installation, operation, or maintenance instructions; owner's modification of the product; owner's abuse, misuse, or negligent acts; and power failure or surges, fire, flood, accident, actions of third parties, or other events outside reasonable control.

Copyright

Under the copyright laws, this publication may not be reproduced or transmitted in any form, electronic or mechanical, including photocopying, recording, storing in an information retrieval system, or translating, in whole or in part, without the prior written consent of National Instruments Corporation.

National Instruments respects the intellectual property of others, and we ask our users to do the same. NI software is protected by copyright and other intellectual property laws. Where NI software may be used to reproduce software or other materials belonging to others, you may use NI software only to reproduce materials that you may reproduce in accordance with the terms of any applicable license or other legal restriction.

Trademarks

National Instruments, NI, ni.com, and LabVIEW are trademarks of National Instruments Corporation. Refer to the *Terms of Use* section on ni.com/legal for more information about National Instruments trademarks.

Other product and company names mentioned herein are trademarks or trade names of their respective companies.

Patents

For patents covering National Instruments products, refer to the appropriate location: **Help»Patents** in your software, the `patents.txt` file on your CD, or ni.com/patents.

WARNING REGARDING USE OF NATIONAL INSTRUMENTS PRODUCTS

(1) NATIONAL INSTRUMENTS PRODUCTS ARE NOT DESIGNED WITH COMPONENTS AND TESTING FOR A LEVEL OF RELIABILITY SUITABLE FOR USE IN OR IN CONNECTION WITH SURGICAL IMPLANTS OR AS CRITICAL COMPONENTS IN ANY LIFE SUPPORT SYSTEMS WHOSE FAILURE TO PERFORM CAN REASONABLY BE EXPECTED TO CAUSE SIGNIFICANT INJURY TO A HUMAN.

(2) IN ANY APPLICATION, INCLUDING THE ABOVE, RELIABILITY OF OPERATION OF THE SOFTWARE PRODUCTS CAN BE IMPAIRED BY ADVERSE FACTORS, INCLUDING BUT NOT LIMITED TO FLUCTUATIONS IN ELECTRICAL POWER SUPPLY, COMPUTER HARDWARE MALFUNCTIONS, COMPUTER OPERATING SYSTEM SOFTWARE FITNESS, FITNESS OF COMPILERS AND DEVELOPMENT SOFTWARE USED TO DEVELOP AN APPLICATION, INSTALLATION ERRORS, SOFTWARE AND HARDWARE COMPATIBILITY PROBLEMS, MALFUNCTIONS OR FAILURES OF ELECTRONIC MONITORING OR CONTROL DEVICES, TRANSIENT FAILURES OF ELECTRONIC SYSTEMS (HARDWARE AND/OR SOFTWARE), UNANTICIPATED USES OR MISUSES, OR ERRORS ON THE PART OF THE USER OR APPLICATIONS DESIGNER (ADVERSE FACTORS SUCH AS THESE ARE HEREAFTER COLLECTIVELY TERMED "SYSTEM FAILURES"). ANY APPLICATION WHERE A SYSTEM FAILURE WOULD CREATE A RISK OF HARM TO PROPERTY OR PERSONS (INCLUDING THE RISK OF BODILY INJURY AND DEATH) SHOULD NOT BE RELIANT SOLELY UPON ONE FORM OF ELECTRONIC SYSTEM DUE TO THE RISK OF SYSTEM FAILURE. TO AVOID DAMAGE, INJURY, OR DEATH, THE USER OR APPLICATION DESIGNER MUST TAKE REASONABLY PRUDENT STEPS TO PROTECT AGAINST SYSTEM FAILURES, INCLUDING BUT NOT LIMITED TO BACK-UP OR SHUT-DOWN MECHANISMS. BECAUSE EACH END-USER SYSTEM IS CUSTOMIZED AND DIFFERS FROM NATIONAL INSTRUMENTS' TESTING PLATFORMS AND BECAUSE A USER OR APPLICATION DESIGNER MAY USE NATIONAL INSTRUMENTS PRODUCTS IN COMBINATION WITH OTHER PRODUCTS IN A MANNER NOT EVALUATED OR CONTEMPLATED BY NATIONAL INSTRUMENTS, THE USER OR APPLICATION DESIGNER IS ULTIMATELY RESPONSIBLE FOR VERIFYING AND VALIDATING THE SUITABILITY OF NATIONAL INSTRUMENTS PRODUCTS WHENEVER NATIONAL INSTRUMENTS PRODUCTS ARE INCORPORATED IN A SYSTEM OR APPLICATION, INCLUDING, WITHOUT LIMITATION, THE APPROPRIATE DESIGN, PROCESS AND SAFETY LEVEL OF SUCH SYSTEM OR APPLICATION.

Conventions

The following conventions are used in this manual:

<>

Angle brackets that contain numbers separated by an ellipsis represent a range of values associated with a bit or signal name—for example, P0.<3..0>.

»

The » symbol leads you through nested menu items and dialog box options to a final action. The sequence **File»Page Setup»Options** directs you to pull down the **File** menu, select the **Page Setup** item, and select **Options** from the last dialog box.



This icon denotes a note, which alerts you to important information.



This icon denotes a caution, which advises you of precautions to take to avoid injury, data loss, or a system crash. When this symbol is marked on the product, refer to the *Read Me First: Safety and Radio-Frequency Interference* document, shipped with the product, for precautions to take.



When symbol is marked on a product it denotes a warning advising you to take precautions to avoid electrical shock.



When symbol is marked on a product it denotes a component that may be hot. Touching this component may result in bodily injury.

bold

Bold text denotes items that you must select or click in the software, such as menu items and dialog box options. Bold text also denotes parameter names.

italic

Italic text denotes variables, emphasis, a cross-reference, hardware labels, or an introduction to a key concept. Italic text also denotes text that is a placeholder for a word or value that you must supply.

monospace

Text in this font denotes text or characters that you should enter from the keyboard, sections of code, programming examples, and syntax examples. This font is also used for the proper names of disk drives, paths, directories, programs, subprograms, subroutines, device names, functions, operations, variables, filenames, and extensions.

Contents

Chapter 1

About the SCXI-1503

What You Need to Get Started	1-1
National Instruments Documentation	1-2
Installing Application Software, NI-DAQ, and the E/M Series DAQ Device	1-4
Installing the SCXI-1503 Module into the SCXI Chassis.....	1-4
Installing the Terminal Block.....	1-4
Configuring the SCXI System Software	1-4
Verifying the SCXI-1503 Installation.....	1-5

Chapter 2

Connecting Signals

Analog Input Signal Connections	2-1
Ground-Referencing the Signals	2-2
Connecting Resistive Devices to the SCXI-1503	2-2
4-Wire Configuration	2-3
2-Wire Configuration	2-4
3-Wire Resistive Sensor Configuration.....	2-5
Lead-Resistance Compensation Using a 3-Wire Resistive Sensor and Two Matched Current Sources	2-6
Front Connector	2-7
Rear Signal Connector	2-10
Rear Signal Connector Descriptions	2-11

Chapter 3

Configuring and Testing

SCXI-1503 Software-Configurable Settings	3-1
Common Software-Configurable Settings	3-1
Gain/Input Range	3-1
Input Coupling	3-2
CJC Source/Value	3-2
Auto-Zero.....	3-2
Configurable Settings in MAX	3-2
NI-DAQmx.....	3-3
Creating a Global Channel or Task.....	3-3
Verifying the Signal.....	3-4
Verifying the Signal in NI-DAQmx Using a Task or Global Channel	3-4

Chapter 4 Theory of Operation

Rear Signal Connector, SCXIBus Connector, and SCXIBus Interface.....	4-3
Digital Control Circuitry	4-3
Analog Circuitry	4-3
Analog Input Channels.....	4-3
Operation of the Current Sources	4-4
Theory of Multiplexed Operation.....	4-4
Measuring Temperature with Resistive Transducers	4-5
RTDs	4-5
RTD Measurement Errors	4-6
The Relationship Between Resistance and Temperature in RTDs...	4-6
Thermistors	4-10
Thermistor Measurement Circuits	4-11
Resistance/Temperature Characteristic of Thermistors.....	4-12

Chapter 5 Using the SCXI-1503

Developing Your Application in NI-DAQmx.....	5-1
Typical Program Flowchart	5-1
General Discussion of Typical Flowchart.....	5-3
Creating a Task Using DAQ Assistant or Programmatically	5-3
Adjusting Timing and Triggering.....	5-3
Configuring Channel Properties	5-4
Acquiring, Analyzing, and Presenting	5-7
Completing the Application.....	5-8
Developing an Application Using LabVIEW	5-8
Using a NI-DAQmx Channel Property Node in LabVIEW	5-10
Specifying Channel Strings in NI-DAQmx	5-11
Text Based ADEs	5-11
Programmable NI-DAQmx Properties	5-13
Calibration	5-13
Internal/Self-Calibration	5-13
External Calibration	5-13

Appendix A Specifications

Appendix B Removing the SCXI-1503

Appendix C Common Questions

Glossary

Index

Figures

Figure 2-1.	4-Wire Resistive Sensor Connected in a 4-Wire Configuration	2-3
Figure 2-2.	2-Wire Resistive Sensor Connected in a 2-Wire Configuration	2-4
Figure 2-3.	3-Wire Resistive Sensor Configuration.....	2-5
Figure 2-4.	3-Wire Configuration Using Matched Current Sources.....	2-6
Figure 4-1.	Block Diagram of SCXI-1503.....	4-2
Figure 4-2.	2-Wire RTD Measurement.....	4-6
Figure 4-3.	Resistance-Temperature Curve for a 100 Ω Platinum RTD, $\alpha = 0.00385$	4-7
Figure 4-4.	Resistance-Temperature Curve for a 2,252 Ω Thermistor	4-11
Figure 4-5.	Thermistor Measurement with Constant Current Excitation	4-11
Figure 5-1.	Typical Program Flowchart for Voltage Measurement Channels.....	5-2
Figure A-1.	SCXI-1503 Dimensions	A-5
Figure B-1.	Removing the SCXI-1503	B-2

Tables

Table 1-1.	Supported SCXI-1503 Terminal Blocks	1-4
Table 2-1.	Front Signal Pin Assignments	2-8
Table 2-2.	Signal Descriptions	2-9
Table 2-3.	Rear Signal Pin Assignments	2-10
Table 2-4.	SCXI-1503 50-Pin Rear Connector Signals	2-11
Table 4-1.	Platinum RTD Types	4-8
Table 5-1.	NI-DAQmx Voltage Measurement Properties	5-4
Table 5-2.	NI-DAQmx RTD Measurement Properties	5-5
Table 5-3.	NI-DAQmx Thermistor Measurement Properties	5-6
Table 5-4.	NI-DAQmx Thermocouple Measurement Properties	5-7
Table 5-5.	Programming a Task in LabVIEW	5-8
Table A-1.	RTD Measurement Accuracy	A-2

About the SCXI-1503

This manual describes the electrical and mechanical aspects of the SCXI-1503 module and contains information concerning its installation and operation. The SCXI-1503 module provides 16 differential input channels and 16 channels of 100 μ A current excitation and one cold junction sensor channel. The SCXI-1503 is ideally suited for measuring resistive transducers, such as RTDs or thermistors.

Each channel has an amplifier with a selectable gain of 1 or 100 and a lowpass filter with a 5 Hz cutoff frequency to reject 50/60 Hz noise.

The SCXI-1503 can programmatically connect each input to ground, which greatly improves its accuracy by enabling a self-calibration of each input to reduce offset drift errors.

You can multiplex several SCXI-1503 modules and other SCXI modules into a single channel on the DAQ device, greatly increasing the number of analog input signals that you can digitize.

Detailed specifications of the SCXI-1503 modules are listed in Appendix A, *Specifications*.

What You Need to Get Started

To set up and use the SCXI-1503, you need the following items:

- Hardware
 - SCXI-1503 module
 - One of the following terminal blocks:
 - SCXI-1306—front-mount terminal block with screw terminal connectivity.
 - SCXI-1310—custom kit for custom connectivity.
 - TBX-96—DIN EN mount terminal block with screw terminal connectivity.
 - SCXI or PXI/SCXI combo chassis

- One of the following:
 - SCXI-1600
 - E/M Series DAQ device
- Computer
- Cabling, cable adapter, and sensors as required for your application
- ☐ Software
 - NI-DAQ 8.1 or later
 - Application software, such as LabVIEW, LabWindows™/CVI™, Measurement Studio, or other programming environments
- ☐ Documentation
 - *Read Me First: Safety and Radio-Frequency Interference*
 - *DAQ Getting Started Guide*
 - *SCXI Quick Start Guide*
 - *SCXI-1503 User Manual*
 - Terminal block installation guide
 - Documentation for your software
- ☐ Tools
 - Wire cutter
 - Wire stripper
 - Flathead screwdriver
 - Phillips screwdriver

National Instruments Documentation

The SCXI-1503 User Manual is one piece of the documentation set for data acquisition (DAQ) systems. You could have any of several types of manuals depending on the hardware and software in the system. Use the manuals you have as follows:

- The *SCXI Quick Start Guide*—This document contains a quick overview for setting up an SCXI chassis, installing SCXI modules and terminal blocks, and attaching sensors. It also describes setting up the SCXI system in MAX.

- SCXI or PXI/SCXI chassis manual—Read this manual for maintenance information on the chassis and for installation instructions.
- The *DAQ Getting Started Guide*—This document has information on installing NI-DAQ and the E/M Series DAQ device. Install these before you install the SCXI module.
- The SCXI hardware user manuals—Read these manuals for detailed information about signal connections and module configuration. They also explain, in greater detail, how the module works and contain application hints.
- Accessory installation guides or manuals—Read the terminal block and cable assembly installation guides. They explain how to physically connect the relevant pieces of the system. Consult these guides when you are making the connections.
- The E/M Series DAQ device documentation—This documentation has detailed information about the DAQ device that plugs into or is connected to the computer. Use this documentation for hardware installation and configuration instructions, specification information about the DAQ device, and application hints.
- Software documentation—You may have both application software and NI-DAQ software documentation. National Instruments (NI) application software includes LabVIEW, LabWindows/CVI, and Measurement Studio. After you set up the hardware system, use either your application software documentation or the NI-DAQ documentation to help you write your application. If you have a large, complex system, it is worthwhile to look through the software documentation before you configure the hardware.
- One or more of the following help files for software information:
 - **Start»Programs»National Instruments»NI-DAQ»NI-DAQmx Help**
 - **Start»Programs»National Instruments»NI-DAQ»Traditional NI-DAQ User Manual**
 - **Start»Programs»National Instruments»NI-DAQ»Traditional NI-DAQ Function Reference Help**

You can download NI documents from ni.com/manuals. To download the latest version of NI-DAQ, click **Drivers and Updates** at ni.com.

Installing Application Software, NI-DAQ, and the E/M Series DAQ Device

Refer to the *DAQ Getting Started Guide* packaged with the NI-DAQ software to install your application software, NI-DAQ driver software, and the DAQ device to which you will connect the SCXI-1503. NI-DAQ 8.1 or later is required to configure and program the SCXI-1503 module. If you do not have NI-DAQ 8.1 or later, you can either contact an NI sales representative to request it on a CD or download the latest NI-DAQ version from ni.com.



Note Refer to the *Read Me First: Radio-Frequency Interference* document before removing equipment covers or connecting or disconnecting any signal wires.

Installing the SCXI-1503 Module into the SCXI Chassis

Refer to the *SCXI Quick Start Guide* to install your SCXI-1503 module.

Installing the Terminal Block

Table 1-1 shows the supported SCXI-1503 terminal blocks. Refer to the *SCXI Quick Start Guide* and the terminal block installation guide for more information about the terminal block.

Table 1-1. Supported SCXI-1503 Terminal Blocks

Terminal Block	CJC Sensor	Measurement Type
SCXI-1306	Yes	Resistive temperature measurements
TBX-96	No	Custom signals
SCXI-1310	No	

Configuring the SCXI System Software

Refer to the *SCXI Quick Start Guide* and the user manuals of the modules in your application to configure and verify them in software.

Verifying the SCXI-1503 Installation

Refer to the *SCXI Quick Start Guide*, for details about testing the SCXI chassis and module installation in software. Refer to Chapter 3, *Configuring and Testing*, for details about setting up a task and verifying the input signal.

Connecting Signals

This chapter describes the input and output signal connections to the SCXI-1503 module with the module front connector and rear signal connector. This chapter also includes connection instructions for the signals on the SCXI-1503 module when using the SCXI-1306 terminal block.

In addition to this section, refer to the installation guide of the terminal block for detailed information regarding connecting the signals. If you are using a custom cable or connector block, refer to the [Front Connector](#) section.

Analog Input Signal Connections

Each differential input (AI+ and AI-) goes to a separate filter and amplifier that is multiplexed to the module output buffer. If the terminal block has a temperature sensor, the sensor output—connected to pins A3 and/or A4 (CJ SENSOR)—is also filtered and multiplexed to the module output buffer.

The differential input signal range of an SCXI-1503 module input channel is ± 10 V when using a gain of 1 or ± 0.1 V when using a gain of 100. This differential input range is the maximum measurable voltage difference between the positive and negative channel inputs. The common-mode input signal range of an SCXI-1503 module input channel is ± 10 V. This common-mode input range for either positive or negative channel input is the maximum input voltage that results in a valid measurement. Each channel includes input protection circuitry to withstand the accidental application of voltages up to ± 42 VDC powered on or ± 25 VDC powered off.



Caution Exceeding the input damage level (± 42 VDC powered on or ± 25 VDC powered off between input channels and chassis ground) can damage the SCXI-1503 module, the SCXIbus, and the DAQ device. NI is *not* liable for any injuries resulting from such signal connections.



Note Exceeding the differential or common-mode input channel ranges results in a distorted signal measurement, and can also increase the settling time requirement of the connected E/M Series DAQ device.

Ground-Referencing the Signals

Do not ground signals that are already ground-referenced; doing so results in a ground loop, which can adversely affect the measurement accuracy. Directly grounding floating signals to the chassis ground without using a bias resistor is not recommended as this can result in noisy readings

Connecting Resistive Devices to the SCXI-1503

You can connect resistive devices to the SCXI signal conditioning system in a 4-, 2-, or 3-wire configuration. Figures 2-1 through 2-4 illustrate various ways to connect sensors for current excitation and voltage measurements using the SCXI-1503 with the SCXI-1306 terminal block.

Refer to the appropriate ADE and SCXI documentation for information concerning setting appropriate voltage gains for the analog inputs.

You can use the SCXI-1306 terminal block to make signal connections to the SCXI-1503. When using the SCXI-1306 terminal block, refer to the *SCXI-1306 Terminal Block Installation Guide*.

4-Wire Configuration

The 4-wire configuration, also referred to as a Kelvin connection, is shown in Figure 2-1. The 4-wire configuration uses one pair of wires to deliver the excitation current to the resistive sensor and uses a separate pair of wires to sense the voltage across the resistive sensor. Because of the high input impedance of the differential amplifier, negligible current flows through the sense wires. This results in a very small lead-resistance voltage drop error. The main disadvantage of the 4-wire connection is the greater number of field wires required.

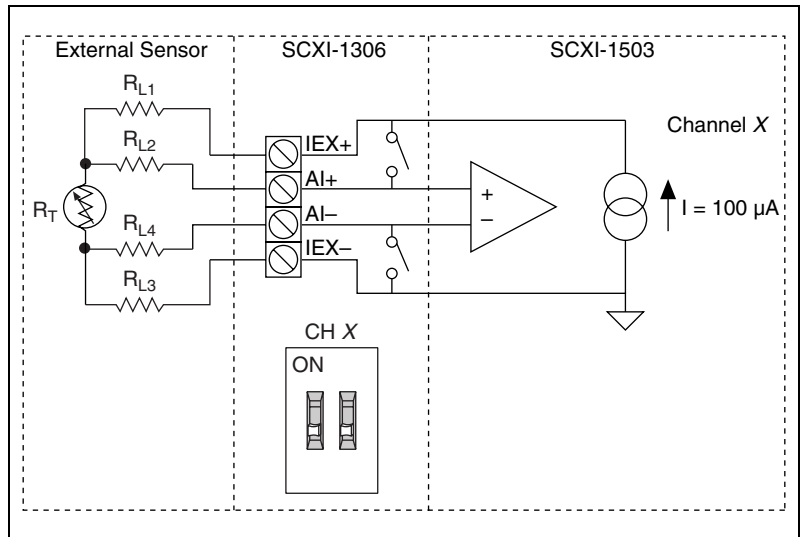

Figure 2-1. 4-Wire Resistive Sensor Connected in a 4-Wire Configuration

2-Wire Configuration

The basic 2-wire configuration is shown in Figure 2-2. In this configuration an error voltage (V_E) is introduced into the measurement equal to the excitation current (I_{EX}) times the sum of the two lead resistances, R_{L1} and R_{L2} . If we assume equal lead resistances, $R_{L1} = R_{L2} = R_L$, the magnitude of the error voltage is:

$$V_E = 2R_L I_{EX}$$

This is the most commonly used configuration for connecting thermistors to a signal conditioning system because the large sensitivity of thermistors usually results in the introduction of a negligible error by the lead resistances.

RTDs typically have a much smaller sensitivity and nominal resistance than thermistors, therefore a 2-wire configuration usually results in the introduction of larger errors by the lead resistance.

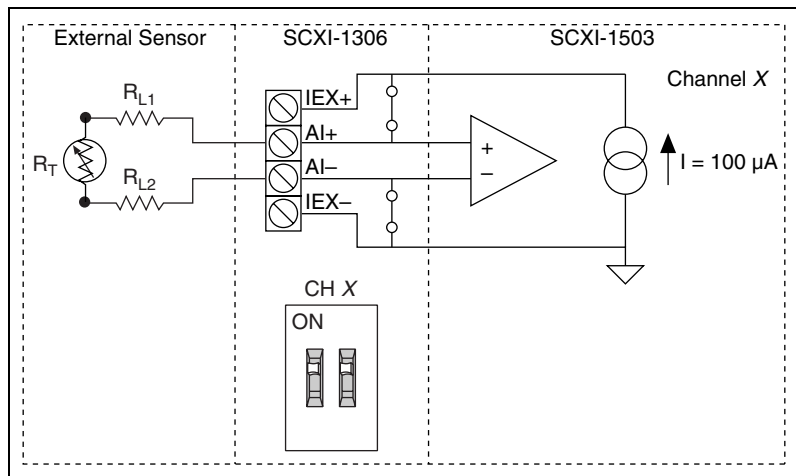

Figure 2-2. 2-Wire Resistive Sensor Connected in a 2-Wire Configuration

3-Wire Resistive Sensor Configuration

If you are using a 3-wire resistive sensor, you can reduce the error voltage by one-half over the 2-wire measurement by connecting the device as shown in Figure 2-3. In this configuration, very little current flows through R_{L3} and therefore R_{L2} is the only lead resistance that introduces an error into the measurement. The resulting measurement error is:

$$VE = R_{L2}I_{EX}$$

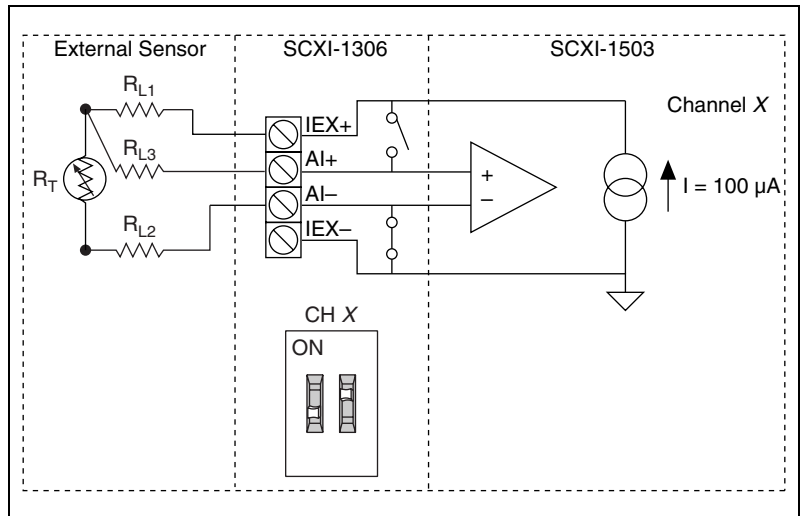

Figure 2-3. 3-Wire Resistive Sensor Configuration

Lead-Resistance Compensation Using a 3-Wire Resistive Sensor and Two Matched Current Sources

You can compensate for the errors introduced by lead-resistance voltage drops by using a 3-wire resistive sensor and two matched current sources connected as shown in Figure 2-4.

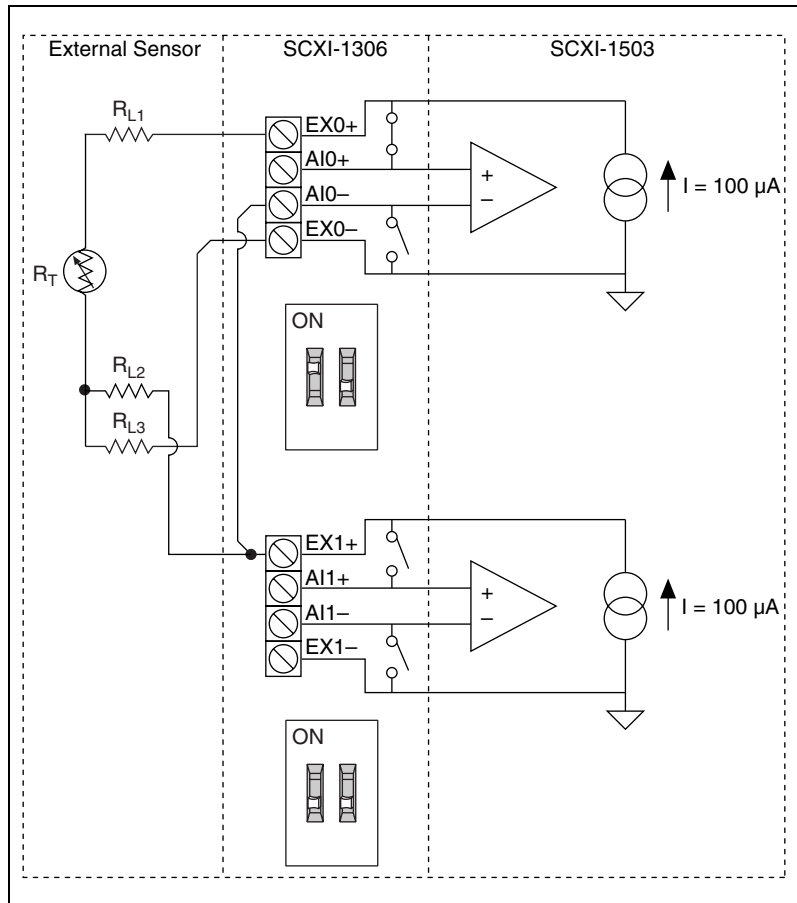

Figure 2-4. 3-Wire Configuration Using Matched Current Sources

In this configuration, the lead-resistance voltage drop across R_{L3} is converted into a common-mode voltage that is rejected by the differential amplifier. Also, the polarity of the lead-resistance voltage drops across R_{L1} and R_{L2} are series opposing, relative to the inputs of the differential amplifier, eliminating their effect on the voltage measured across R_T .



Note R_{L1} and R_{L2} are assumed to be equal.

The effectiveness of this method depends on the matching of the current sources. Each current source on the SCXI-1503 has an accuracy of $\pm 0.05\%$. This accuracy results in a worst-case matching of $\pm 0.1\%$. Refer to the Chapter 4, *Theory of Operation*, for accuracy considerations of RTDs and thermistors.

Front Connector

The pin assignments for the SCXI-1503 front signal connector are shown in Table 2-1.



Note Do *not* make any connections to RSVD pins.

Table 2-1. Front Signal Pin Assignments

Front Connector Diagram	Pin Number	Column A	Column B	Column C																																																																																																																																				
<div style="text-align: center;">Column</div> <table border="1" style="margin-left: auto; margin-right: auto;"> <tr> <td></td> <td style="text-align: center;">A</td> <td style="text-align: center;">B</td> <td style="text-align: center;">C</td> </tr> <tr> <td style="text-align: center;">32</td> <td style="text-align: center;">○</td> <td style="text-align: center;">○</td> <td style="text-align: center;">○</td> </tr> <tr> <td style="text-align: center;">31</td> <td style="text-align: center;">○</td> <td style="text-align: center;">○</td> <td style="text-align: center;">○</td> </tr> <tr> <td style="text-align: center;">30</td> <td style="text-align: center;">○</td> <td style="text-align: center;">○</td> <td style="text-align: center;">○</td> </tr> <tr> <td style="text-align: center;">29</td> <td style="text-align: center;">○</td> <td style="text-align: center;">○</td> <td style="text-align: center;">○</td> </tr> <tr> <td style="text-align: center;">28</td> <td style="text-align: center;">○</td> <td style="text-align: center;">○</td> <td style="text-align: center;">○</td> </tr> <tr> <td style="text-align: center;">27</td> <td style="text-align: center;">○</td> <td style="text-align: center;">○</td> <td style="text-align: center;">○</td> </tr> <tr> <td style="text-align: center;">26</td> <td style="text-align: center;">○</td> <td style="text-align: center;">○</td> <td style="text-align: center;">○</td> </tr> <tr> <td style="text-align: center;">25</td> <td style="text-align: center;">○</td> <td style="text-align: center;">○</td> <td style="text-align: center;">○</td> </tr> <tr> <td style="text-align: center;">24</td> <td style="text-align: center;">○</td> <td style="text-align: center;">○</td> <td style="text-align: center;">○</td> </tr> <tr> <td style="text-align: center;">23</td> <td style="text-align: center;">○</td> <td style="text-align: center;">○</td> <td style="text-align: center;">○</td> </tr> <tr> <td style="text-align: center;">22</td> <td style="text-align: center;">○</td> <td style="text-align: center;">○</td> <td style="text-align: center;">○</td> </tr> <tr> <td style="text-align: center;">21</td> <td style="text-align: center;">○</td> <td style="text-align: center;">○</td> <td style="text-align: center;">○</td> </tr> <tr> <td style="text-align: center;">20</td> <td style="text-align: center;">○</td> <td style="text-align: center;">○</td> <td style="text-align: center;">○</td> </tr> <tr> <td style="text-align: center;">19</td> <td style="text-align: center;">○</td> <td style="text-align: center;">○</td> <td style="text-align: center;">○</td> </tr> <tr> <td style="text-align: center;">18</td> <td style="text-align: center;">○</td> <td style="text-align: center;">○</td> <td style="text-align: center;">○</td> </tr> <tr> <td style="text-align: center;">17</td> <td style="text-align: center;">○</td> <td style="text-align: center;">○</td> <td style="text-align: center;">○</td> </tr> <tr> <td style="text-align: center;">16</td> <td style="text-align: center;">○</td> <td style="text-align: center;">○</td> <td style="text-align: center;">○</td> </tr> <tr> <td style="text-align: center;">15</td> <td style="text-align: center;">○</td> <td style="text-align: center;">○</td> <td style="text-align: center;">○</td> </tr> <tr> <td style="text-align: center;">14</td> <td style="text-align: center;">○</td> <td style="text-align: center;">○</td> <td style="text-align: center;">○</td> </tr> <tr> <td style="text-align: center;">13</td> <td style="text-align: center;">○</td> <td style="text-align: center;">○</td> <td style="text-align: center;">○</td> </tr> <tr> <td style="text-align: center;">12</td> <td style="text-align: center;">○</td> <td style="text-align: center;">○</td> <td style="text-align: center;">○</td> </tr> <tr> <td style="text-align: center;">11</td> <td style="text-align: center;">○</td> <td style="text-align: center;">○</td> <td style="text-align: center;">○</td> </tr> <tr> <td style="text-align: center;">10</td> <td style="text-align: center;">○</td> <td style="text-align: center;">○</td> <td style="text-align: center;">○</td> </tr> <tr> <td style="text-align: center;">9</td> <td style="text-align: center;">○</td> <td style="text-align: center;">○</td> <td style="text-align: center;">○</td> </tr> <tr> <td style="text-align: center;">8</td> <td style="text-align: center;">○</td> <td style="text-align: center;">○</td> <td style="text-align: center;">○</td> </tr> <tr> <td style="text-align: center;">7</td> <td style="text-align: center;">○</td> <td style="text-align: center;">○</td> <td style="text-align: center;">○</td> </tr> <tr> <td style="text-align: center;">6</td> <td style="text-align: center;">○</td> <td style="text-align: center;">○</td> <td style="text-align: center;">○</td> </tr> <tr> <td style="text-align: center;">5</td> <td style="text-align: center;">○</td> <td style="text-align: center;">○</td> <td style="text-align: center;">○</td> </tr> <tr> <td style="text-align: center;">4</td> <td style="text-align: center;">○</td> <td style="text-align: center;">○</td> <td style="text-align: center;">○</td> </tr> <tr> <td style="text-align: center;">3</td> <td style="text-align: center;">○</td> <td style="text-align: center;">○</td> <td style="text-align: center;">○</td> </tr> <tr> <td style="text-align: center;">2</td> <td style="text-align: center;">○</td> <td style="text-align: center;">○</td> <td style="text-align: center;">○</td> </tr> <tr> <td style="text-align: center;">1</td> <td style="text-align: center;">○</td> <td style="text-align: center;">○</td> <td style="text-align: center;">○</td> </tr> </table>		A	B	C	32	○	○	○	31	○	○	○	30	○	○	○	29	○	○	○	28	○	○	○	27	○	○	○	26	○	○	○	25	○	○	○	24	○	○	○	23	○	○	○	22	○	○	○	21	○	○	○	20	○	○	○	19	○	○	○	18	○	○	○	17	○	○	○	16	○	○	○	15	○	○	○	14	○	○	○	13	○	○	○	12	○	○	○	11	○	○	○	10	○	○	○	9	○	○	○	8	○	○	○	7	○	○	○	6	○	○	○	5	○	○	○	4	○	○	○	3	○	○	○	2	○	○	○	1	○	○	○	32	GND	AI0-	AI0+
		A	B	C																																																																																																																																				
	32	○	○	○																																																																																																																																				
	31	○	○	○																																																																																																																																				
	30	○	○	○																																																																																																																																				
	29	○	○	○																																																																																																																																				
	28	○	○	○																																																																																																																																				
	27	○	○	○																																																																																																																																				
	26	○	○	○																																																																																																																																				
	25	○	○	○																																																																																																																																				
	24	○	○	○																																																																																																																																				
	23	○	○	○																																																																																																																																				
	22	○	○	○																																																																																																																																				
	21	○	○	○																																																																																																																																				
	20	○	○	○																																																																																																																																				
	19	○	○	○																																																																																																																																				
	18	○	○	○																																																																																																																																				
	17	○	○	○																																																																																																																																				
	16	○	○	○																																																																																																																																				
	15	○	○	○																																																																																																																																				
	14	○	○	○																																																																																																																																				
	13	○	○	○																																																																																																																																				
	12	○	○	○																																																																																																																																				
	11	○	○	○																																																																																																																																				
	10	○	○	○																																																																																																																																				
	9	○	○	○																																																																																																																																				
	8	○	○	○																																																																																																																																				
	7	○	○	○																																																																																																																																				
	6	○	○	○																																																																																																																																				
	5	○	○	○																																																																																																																																				
	4	○	○	○																																																																																																																																				
	3	○	○	○																																																																																																																																				
2	○	○	○																																																																																																																																					
1	○	○	○																																																																																																																																					
31	GND	AI1-	AI1+																																																																																																																																					
30	GND	AI2-	AI2+																																																																																																																																					
29	GND	AI3-	AI3+																																																																																																																																					
28	RSVD	AI4-	AI4+																																																																																																																																					
27	RSVD	AI5-	AI5+																																																																																																																																					
26	RSVD	AI6-	AI6+																																																																																																																																					
25	RSVD	AI7-	AI7+																																																																																																																																					
24	NC	IEX0-	IEX0+																																																																																																																																					
23	NC	IEX1-	IEX1+																																																																																																																																					
22	NC	IEX2-	IEX2+																																																																																																																																					
21	NC	IEX3-	IEX3+																																																																																																																																					
20	RSVD	IEX4-	IEX4+																																																																																																																																					
19	RSVD	IEX5	IEX5+																																																																																																																																					
18	NC	IEX6-	IEX6+																																																																																																																																					
17	NC	IEX7-	IEX7+																																																																																																																																					
16	GND	AI8-	AI8+																																																																																																																																					
15	GND	AI9-	AI9+																																																																																																																																					
14	GND	AI10-	AI10+																																																																																																																																					
13	GND	AI11-	AI11+																																																																																																																																					
12	NC	AI12-	AI12+																																																																																																																																					
11	NC	AI13-	AI13+																																																																																																																																					
10	NC	AI14-	AI14+																																																																																																																																					
9	NC	AI15-	AI15+																																																																																																																																					
8	NC	IEX8-	IEX8+																																																																																																																																					
7	NC	IEX9-	IEX9+																																																																																																																																					
6	NC	IEX10-	IEX10+																																																																																																																																					
5	NC	IEX11-	IEX11+																																																																																																																																					
4	CJ SENSOR	IEX12-	IEX12+																																																																																																																																					
3	CJ SENSOR	IEX13-	IEX13+																																																																																																																																					
NC—no connection	2	CGND	IEX14-	IEX14+																																																																																																																																				
RSVD—reserved	1	+5 V	IEX15-	IEX15+																																																																																																																																				

Table 2-2. Signal Descriptions

Pin	Signal Name	Description
A1	+5 V	+5 VDC Source—Used to power circuitry on the terminal block. 0.1 mA of source not protected.
A13 – A16, A29 – A32	GND	Ground—Tied to the SCXI module ground.
A1, A19, A20, A25 – A28	RSVD	Reserved—This pin is reserved. Do <i>not</i> connect any signal to this pin.
A2	C GND	Chassis Ground—Connects to the SCXI chassis.
B24 – B17, B8 – B1	IEX<0..7> –, IEX<8..15> –	Negative Excitation—Connects to the channel ground reference. This is the return path for the corresponding IEX+ channel.
C24 – C17, C8 – C1	IEX<0..7> +, IEX<8..15> +	Positive Excitation—Connects to the positive current output of the channel.
A3, A4	CJ SENSOR	Cold-Junction Temperature Sensor Input—Connects to the temperature sensor of the terminal block.
B30 – B 25, B16 – B9	AI <0..7> –, AI <8..15> –	Negative Input Channels—Negative side of differential input channels.
C32 – C25, C16 – C9	AI <0..7> +, AI <8..15> +	Positive Input Channels—Positive side of differential input channels.

Rear Signal Connector

Table 2-3 shows the SCXI-1503 module rear signal connector pin assignments.

Table 2-3. Rear Signal Pin Assignments

Rear Connector Diagram	Signal Name	Pin Number	Pin Number	Signal Name
	AI GND	1	2	AI GND
	AI 0 +	3	4	AI 0 –
	NC	5	6	NC
	NC	7	8	NC
	NC	9	10	NC
	NC	11	12	NC
	NC	13	14	NC
	NC	15	16	NC
	NC	17	18	NC
	NC	19	20	NC
	NC	21	22	NC
	NC	23	24	DIG GND
	SER DAT IN	25	26	SER DAT OUT
	DAQ D*/A	27	28	NC
	SLOT 0 SEL*	29	30	NC
	NC	31	32	NC
	DIG GND	33	34	NC
	NC	35	36	SCAN CLK
	SER CLK	37	38	NC
	NC	39	40	NC
	NC	41	42	NC
	RSVD	43	44	NC
	NC	45	46	RSVD
NC means no connection.	NC	47	48	NC
RSVD means reserved.	NC	49	50	NC

Rear Signal Connector Descriptions

The rear signal connector on the cabled module is the interface between the DAQ device and all modules in the SCXI chassis. AI 0 is used to differentially multiplex all 16 channels, the CJ sensor, and analog signals from the modules to the connected DAQ device.

The communication signals between the DAQ device and the SCXI system are listed in Table 2-4. If the DAQ device is connected to the SCXI-1503, these digital lines are unavailable for general-purpose digital I/O.

Table 2-4. SCXI-1503 50-Pin Rear Connector Signals

Pin	SCXI Signal Name	NI-DAQmx Device Signal Name	Direction	Description
1, 2	AI GND	AI GND	—	Analog input ground—connects to the analog input ground of the DAQ device.
3	AI 0 +	AI 0 +	Input	Channel 0 positive—used to differentially multiplex all 16 channels, the CJ sensor, and analog signals from the modules to the connected DAQ device.
4	AI 0 –	AI 0 –	Input	Channel 0 negative—used to differentially multiplex all 16 channels, the CJ sensor, and analog signals from the modules to the connected DAQ device.
24, 33	DIG GND	D GND	—	Digital ground—these pins supply the reference for E/M Series DAQ device digital signals and are connected to the module digital ground.
25	SER DAT IN	P0.0	Input	Serial data in—this signal taps into the SCXIbus MOSI line to send serial input data to a module or Slot 0.

Table 2-4. SCXI-1503 50-Pin Rear Connector Signals (Continued)

Pin	SCXI Signal Name	NI-DAQmx Device Signal Name	Direction	Description
26	SER DAT OUT	P0.4	Output	Serial data out—this signal taps into the SCXIBus MISO line to accept serial output data from a module.
27	DAQ D*/A	P0.1	Input	Board data/address line—this signal taps into the SCXIBus D*/A line to indicate to the module whether the incoming serial stream is data or address information.
29	SLOT 0 SEL*	P0.2	Input	Slot 0 select—this signal taps into the SCXIBus INTR* line to indicate whether the information on MOSI is being sent to a module or Slot 0.
36	SCAN CLK	AI HOLD COMP, AI HOLD	Input	Scan clock—a rising edge indicates to the scanned SCXI module that the E/M Series DAQ device has taken a sample and causes the module to advance channels.
37	SER CLK	EXTSTROBE*	Input	Serial clock—this signal taps into the SCXIBus SPICLK line to clock the data on the MOSI and MISO lines.
43, 46	RSVD	RSVD	Input	Reserved.
Note: All other pins are not connected.				

Configuring and Testing

This chapter discusses configuring the SCXI-1503 in MAX using NI-DAQmx, creating and testing a virtual channel, global channel, and/or task.



Notes You must have NI-DAQmx 8.1 or later installed.

Refer to the *SCXI Quick Start Guide* if you have not already configured the chassis.

SCXI-1503 Software-Configurable Settings

This section describes how to set the gain/input signal range and how to configure your software for compatible sensor types. It also describes how to perform configuration of these settings for the SCXI-1503 in NI-DAQmx. For more information on the relationship between the settings and the measurements and how to configure settings in your application, refer to Chapter 4, *Theory of Operation*.

Common Software-Configurable Settings

This section describes the most frequently used software-configurable settings for the SCXI-1503. Refer to Chapter 5, *Using the SCXI-1503*, for a complete list of software-configurable settings.

Gain/Input Range

Gain/input range is a software-configurable setting that allows you to choose the appropriate amplification to fully utilize the range of the E/M Series DAQ device. In most applications NI-DAQ chooses and sets the gain for you determined by the input range. This feature is described in Chapter 5, *Using the SCXI-1503*. Otherwise, you should determine the appropriate gain using the input signal voltage range and the full-scale limits of the SCXI-1503 output. You can select a gain of 1 or 100 on a per channel basis.

Input Coupling

The front end of the SCXI-1503 includes a software configurable switch that allows you to programmatically connect the input channels of the SCXI-1503 to either the front connector or internal ground. When using autozero, the coupling mode is set automatically. Refer to Table 5-1, *NI-DAQmx Voltage Measurement Properties*, for details about the available input coupling modes supported by the SCXI-1503.

CJC Source/Value

When using a terminal block that has a CJ sensor for thermocouple measurements, you can set the CJC source as internal, which scans the sensor at the beginning of each measurement and scales the readings accordingly.

Auto-Zero

Setting the Auto-zero mode to *Once* improves the accuracy of the measurement. With auto-zero enabled, the inputs of the SCXI-1503 are internally grounded. The driver makes a measurement when the task begins and then subtracts the measured offset from all future measurements.

Configurable Settings in MAX



Note If you are not using an NI ADE or are using an unlicensed copy of an NI ADE, additional dialog boxes from the NI License Manager appear allowing you to create a task or global channel in unlicensed mode. These messages continue to appear until you install version 8.1 or later of an NI ADE.

This section describes where you can access each software-configurable setting in MAX. The location of the settings varies depending on the version of NI-DAQmx you use. Refer to the *DAQ Getting Started Guide* and the *SCXI Quick Start Guide* for more information on installing and configuring the hardware. You can use DAQ Assistant to graphically configure common measurement tasks, channels, or scales.

NI-DAQmx

Using NI-DAQmx, you can configure software settings such as sensor type and gain/input signal range in the following ways:

- Task or global channel in MAX
- Functions in your application



Note All software-configurable settings are not configurable both ways. This section only discusses settings in MAX. Refer to Chapter 5, *Using the SCXI-1503*, for information on using functions in your application.

Dependent upon the terminal block configuration use, you can use the SCXI-1503 module to make the following types of measurements:

- Voltage input
- Thermocouple
- RTD
- Thermistors

Creating a Global Channel or Task

To create a new voltage, temperature, or current input NI-DAQmx global task or channel, complete the following steps:

1. Double-click **Measurement & Automation** on the desktop.
2. Right-click **Data Neighborhood** and select **Create New**.
3. Select **NI-DAQmx Task** or **NI-DAQmx Global Channel**, and click **Next**.
4. Select **Analog Input**.
5. Select one of the following:
 - **Voltage**
 - **Temperature** and then select one of the following:
 - **Iex Thermistor**
 - **RTD**
 - **Thermocouple**
 - **Vex Thermistor**
6. If you are creating a task, you can select a range of channels by holding down the <Shift> key while selecting the channels. You can select multiple individual channels by holding down the <Ctrl> key while

selecting channels. If you are creating a channel, you can only select one channel. Click **Next**.

7. Name the task or channel and click **Finish**.
8. Select the channel(s) you want to configure. You can select a range of channels by holding down the <Shift> key while selecting the channels. You can select multiple individual channels by holding down the <Ctrl> key while selecting channels.



Note If you want to add channels of various measurement types to the same task, click the **Add Channels** button to select the measurement type for the additional channels.

9. Enter the specific values for your application in the **Settings** tab. Context help information for each setting is provided on the right side of the screen. Configure the input signal range using either **NI-DAQmx Task** or **NI-DAQmx Global Channel**. When you set the minimum and maximum range of **NI-DAQmx Task** or **NI-DAQmx Global Channel**, the driver selects the best gain for the measurement. You also can set it through your application.
10. If you are creating a task and want to set timing or triggering controls, enter the values in the **Task Timing** and **Task Triggering** tabs.
11. Click **Device** and select **Auto Zero** mode if desired.

Verifying the Signal

This section describes how to take measurements using test panels in order to verify signal, and configuring and installing a system in NI-DAQmx.

Verifying the Signal in NI-DAQmx Using a Task or Global Channel

You can verify the signals on the SCXI-1503 using NI-DAQmx by completing the following steps:

1. Expand **Data Neighborhood**.
2. Expand **NI-DAQmx Tasks**.
3. Click the task you created in the *Creating a Global Channel or Task* section.
4. Select the channel(s) you want to verify. You can select a block of channels by holding down the <Shift> key or multiple channels by holding down the <Ctrl> key. Click **OK**.
5. Enter the appropriate information on the **Settings** and **Device** tab.

6. Click the **Test** button.
7. Click the **Start** button.
8. After you have completed verifying the channels, click the **Stop** button.

You have now verified the SCXI-1503 configuration and signal connection.



Note For more information on how to further configure the SCXI-1503, or how to use LabVIEW to configure the module and take measurements, refer to Chapter 5, [Using the SCXI-1503](#).

Theory of Operation

This chapter provides a brief overview and a detailed discussion of the circuit features of the SCXI-1503 module. Refer to Figure 4-1 while reading this section.

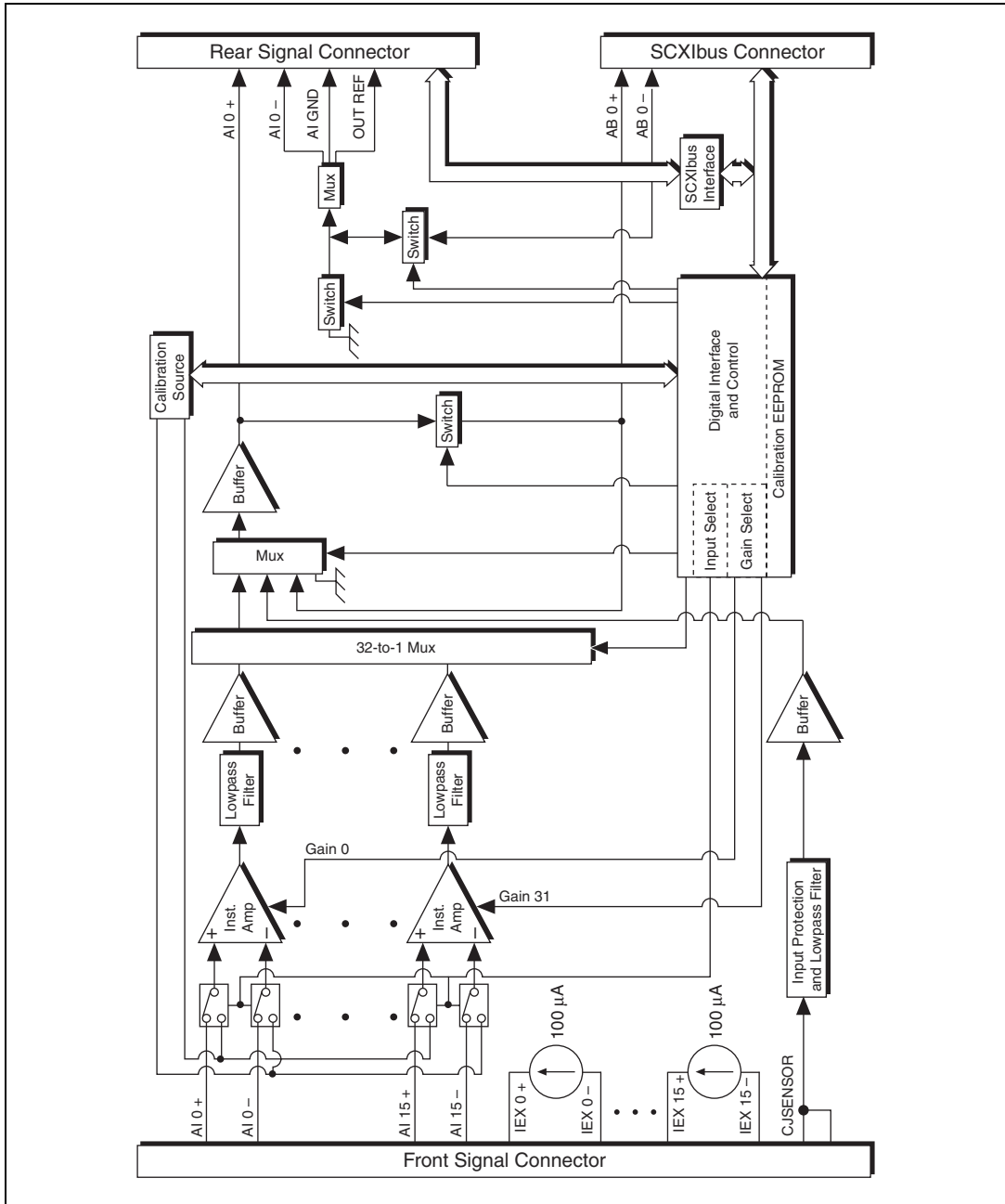

Figure 4-1. Block Diagram of SCXI-1503

The major components of the SCXI-1503 modules are as follows:

- Rear signal connector
- SCXIbus connector
- SCXIbus interface
- Digital control circuitry
- Analog circuitry

The SCXI-1503 modules consist of 16 multiplexed input channels, each with a software-programmable gain of 1 or 100. Each input channel has its own lowpass filter. Each channel has a fixed 100 μ A current excitation. The SCXI-1503 modules also have a digital section for automatic control of channel scanning, temperature sensor selection, gain selection, and auto-zero mode.

Rear Signal Connector, SCXIbus Connector, and SCXIbus Interface

The SCXIbus controls the SCXI-1503 module. The SCXIbus interface connects the rear signal connector to the SCXIbus, allowing a DAQ device to control the SCXI-1503 module and the rest of the chassis.

Digital Control Circuitry

The digital control circuitry consists of the Address Handler and registers that are necessary for identifying the module, reading/setting calibration information, setting the gain, and selecting the appropriate channel.

Analog Circuitry

The analog circuitry per channel consists of a fixed lowpass filter and an amplifier with a software selectable gain of 1 or 100. The CJ SENSOR channel has a lowpass filter buffered by a unity gain amplifier. The channels and CJ SENSOR are multiplexed to a single output buffer.

Analog Input Channels

Each of the 16 differential analog input channels feeds to a separate instrumentation amplifier with a programmable gain of 1 or 100. Each channel has a fixed 100 μ A current excitation. Then the signal passes through a fixed 2-pole, 5 Hz lowpass filter.

The CJ SENSOR input channel is used to read the sensor temperature from the terminal block. The temperature sensor is for cold-junction compensation of thermocouple measurements. The CJ SENSOR channel also passes through a 5 Hz lowpass filter to reject unwanted noise on the SCXI-1503. Along with the other 16 input channels, the CJ SENSOR is multiplexed to the output buffer, where it can be read by the DAQ device.

Operation of the Current Sources

The current sources on the SCXI-1503 continuously provide 16 channels of 100 μ A current excitation. These current sources are on whenever the SCXI chassis is powered-on. The current sources on the SCXI-1503 are designed to be accurate to within $\pm 0.05\%$ of the specified value with a temperature drift of no more than ± 5 ppm/ $^{\circ}$ C. The high accuracy and stability of these current sources makes them especially well suited to measuring resistance to a high degree of accuracy.

Theory of Multiplexed Operation

In multiplexed mode, all input channels of an SCXI module are multiplexed into a single analog input channel of the DAQ device. Multiplexed mode operation is ideal for high channel count systems. Multiplexed mode is typically used for performing scanning operations with the SCXI-1503. The power of SCXI multiplexed mode scanning is its ability to route many input channels to a single channel of the DAQ device.

The multiplexing operation of the analog input signals is performed entirely by multiplexers in the SCXI modules, not inside the DAQ device or SCXI chassis. In multiplexed mode the SCXI-1503 scanned channels are kept by the NI-DAQ driver in a scan list. Immediately prior to a multiplexed scanning operation, the SCXI chassis is programmed with a module scan list that controls which module sends its output to the SCXIbus during a scan through the cabled SCXI module.

The list can contain channels in any physical order and the multiplexer can sequence the channel selection from the scan list in any order. The ordering of scanned channels need not be sequential. Channels can occur multiple times in a single scan list. The scan list can contain an arbitrary number of channels for each module entry in the scan list, limited to a total of 512 channels per DAQ device. This is referred to as flexible scanning (random scanning). Not all SCXI modules provide flexible scanning.

The module includes first-in first-out (FIFO) memory for storing the channel scan list defined in your application code. NI-DAQ drivers load the FIFO based on the channel assignments you make in your application. You need not explicitly program the module FIFO as this is done automatically for you by the NI-DAQ driver.

When you configure a module for multiplexed mode operation, the routing of multiplexed signals to the DAQ device depends on which module in the SCXI system is cabled to the DAQ device. There are several possible scenarios for routing signals from the multiplexed modules to the DAQ device.

If the scanned SCXI-1503 module is not directly cabled to the DAQ device, the module sends its signals through the SCXIbus to the cabled module. The cabled module, whose routing is controlled by the SCXI chassis, routes the SCXIbus signals to the DAQ device through the AI 0 pin on its rear signal connector.

If the DAQ device scans the cabled module, the module routes its input signals through the AI 0 pin on its rear signal connector to a single channel on the DAQ device.

Measuring Temperature with Resistive Transducers

This section discusses RTDs and thermistors, and describes accuracy considerations when connecting resistive transducers to the signal conditioning system.

RTDs

A resistive-temperature detector (RTD) is a temperature-sensing device whose resistance increases with temperature. An RTD consists of a wire coil or deposited film of pure metal. RTDs are made of different metals and have different resistances, but the most popular RTD is made of platinum and has a nominal resistance of 100 Ω at 0 $^{\circ}\text{C}$.

RTDs are known for their excellent accuracy over a wide temperature range. Some RTDs have accuracies as high as 0.01 Ω (0.026 $^{\circ}\text{C}$) at 0 $^{\circ}\text{C}$. RTDs are also extremely stable devices. Common industrial RTDs drift less than 0.1 $^{\circ}\text{C}/\text{year}$, and some models are stable to within 0.0025 $^{\circ}\text{C}/\text{year}$.

RTDs are sometimes difficult to measure because they have relatively low nominal resistance (commonly 100 Ω) that changes only slightly with temperature (less than 0.4 $\Omega/^{\circ}\text{C}$). To accurately measure these small

changes in resistance, you must use special configurations that minimize measured errors caused by lead-wire resistance.

RTD Measurement Errors

Because the RTD is a resistive device, you must pass a current through the device and monitor the resulting voltage. However, any resistance in the lead wires that connect the measurement system to the RTD adds error to the readings. For example, consider a 2-wire RTD element connected to a measurement system that also supplies a constant current, I_{EX} , to excite the RTD. As shown in Figure 4-2, the voltage drop across the lead resistances (labeled R_L) adds an error voltage to the measured voltage.

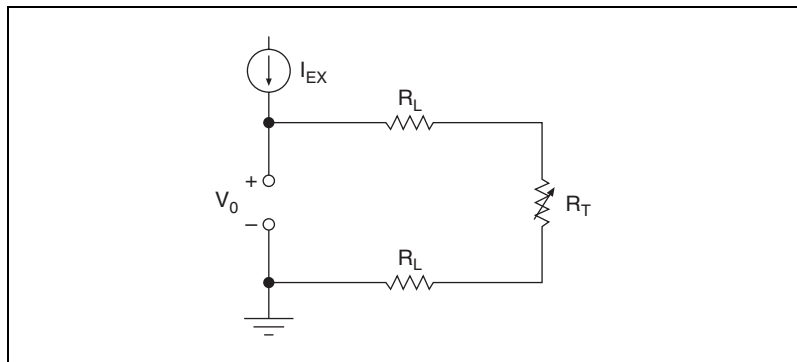

Figure 4-2. 2-Wire RTD Measurement

For example, a lead resistance of 0.3Ω in each wire adds a 0.6Ω error to the resistance measurement. For a platinum RTD at 0°C with $\alpha = 0.00385$, the lead resistance equates to an error of approximately

$$\frac{0.6 \Omega}{0.385 \Omega/^\circ\text{C}} = 1.6^\circ\text{C}$$

Chapter 2, *Connecting Signals*, describes different ways of connecting resistive devices to the SCXI system.

The Relationship Between Resistance and Temperature in RTDs

Compared to other temperature-measurement devices, the output of an RTD is relatively linear with respect to temperature. The temperature coefficient, called alpha (α), differs between RTD curves. Although various manufacturers specify alpha differently, alpha is most commonly

defined as the change in RTD resistance from 0 to 100 °C, divided by the resistance at 0 °C, divided by 100 °C:

$$\alpha(\Omega/\Omega/^{\circ}C) = \frac{R_{100} - R_0}{R_0 \times 100^{\circ}C}$$

where

R_{100} is the resistance of the RTD at 100 °C.

R_0 is the resistance of the RTD at 0 °C.

For example, a 100 Ω platinum RTD with $\alpha = 0.003911$ has a resistance of 139.11 Ω at 100 °C.

Figure 4-3 displays a typical resistance-temperature curve for a 100 Ω platinum RTD.

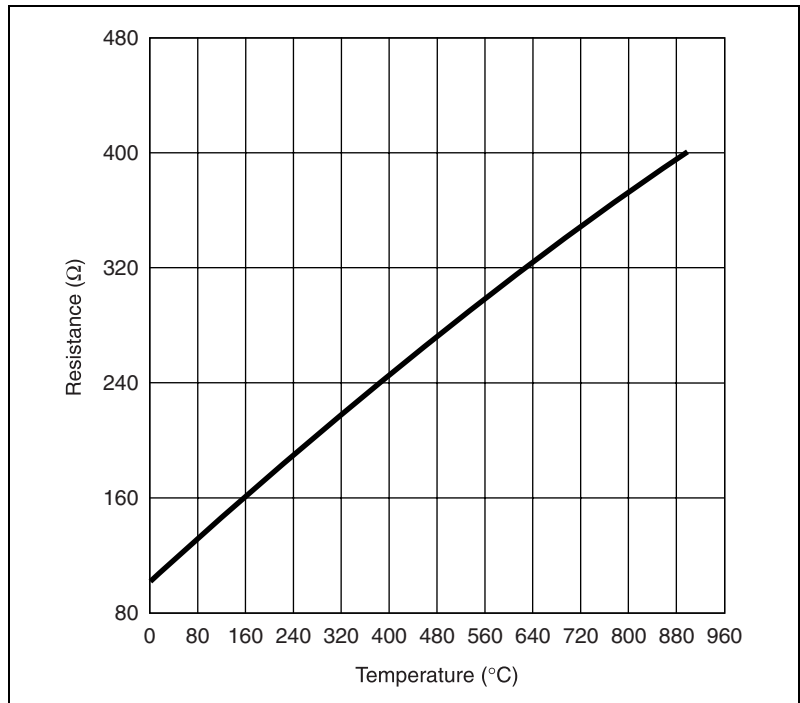

Figure 4-3. Resistance-Temperature Curve for a 100 Ω Platinum RTD, $\alpha = 0.00385$

Although the resistance-temperature curve is relatively linear, accurately converting measured resistance to temperature requires curve fitting. The following Callendar-Van Dusen equation is commonly used to approximate the RTD curve:

$$R_T = R_0[1 + AT + BT^2 + C(T - 100)^3]$$

where

R_T is the resistance of the RTD at temperature T .

R_0 is the resistance of the RTD at 0 °C.

A , B , and C are the Callendar-Van Dusen coefficients shown in Table 4-1.

T is the temperature in °C.

Table 4-1 lists the RTD types and their corresponding coefficients.

Table 4-1. Platinum RTD Types

Standard	Temperature Coefficient of Resistance (TCR, PPM)	Typical R_0	Callendar-Van Dusen Coefficient
IEC-751 DIN 43760 BS 1904 ASTM-E1137 EN-60751	3851	100 Ω 1000 Ω	$A = 3.9083 \times 10^{-3}$ $B = -5.775 \times 10^{-7}$ $C = -4.183 \times 10^{-12}$
Low cost vendor compliant ¹	3750	1000 Ω	$A = 3.81 \times 10^{-3}$ $B = -6.02 \times 10^{-7}$ $C = -6.0 \times 10^{-12}$
JISC 1604	3916	100 Ω	$A = 3.9739 \times 10^{-3}$ $B = -5.870 \times 10^{-7}$ $C = -4.4 \times 10^{-12}$
US Industrial Standard D-100 American	3920	100 Ω	$A = 3.9787 \times 10^{-3}$ $B = -5.8686 \times 10^{-7}$ $C = -4.167 \times 10^{-12}$

Table 4-1. Platinum RTD Types (Continued)

Standard	Temperature Coefficient of Resistance (TCR, PPM)	Typical R_0	Callendar-Van Dusen Coefficient
US Industrial Standard American	3911	100 Ω	$A = 3.9692 \times 10^{-3}$ $B = -5.8495 \times 10^{-7}$ $C = -4.233 \times 10^{-12}$
ITS-90	3928	100 Ω	$A = 3.9888 \times 10^{-3}$ $B = -5.915 \times 10^{-7}$ $C = -3.85 \times 10^{-12}$
¹ No standard. Check TCR.			

For temperatures above 0 °C, coefficient C equals 0, reducing this equation to a quadratic. If you pass a known current, I_{EX} , through the RTD and measure the output voltage developed across the RTD, V_0 , you can solve for T as follows:

$$T = \frac{R_0 - \frac{V_0}{I_{EX}}}{-0.5 \left(R_0 A + \sqrt{R_0^2 A^2 - 4 R_0 B \left(R_0 - \frac{V_0}{I_{EX}} \right)} \right)}$$

where

V_0 is the measured RTD voltage.

I_{EX} is the excitation current.

Thermistors

A thermistor is a piece of semiconductor made from metal oxides, pressed into a small bead, disk, wafer, or other shape, sintered at high temperatures, and finally coated with epoxy or glass. The resulting device exhibits an electrical resistance that varies with temperature.

There are two types of thermistors: negative temperature coefficient (NTC) thermistors, whose resistance decreases with increasing temperature, and positive temperature coefficient (PTC) thermistors, whose resistance increases with increasing temperature. NTC thermistors are more commonly used than PTC thermistors, especially for temperature measurement applications.

A main advantage of thermistors for temperature measurement is their extremely high sensitivity. For example, a 2,252 Ω thermistor has a sensitivity of $-100 \Omega/^\circ\text{C}$ at room temperature. Higher resistance thermistors can exhibit temperature coefficients of $-10 \text{ k}\Omega/^\circ\text{C}$ or more. In comparison, a 100 Ω platinum RTD has a sensitivity of only $0.4 \Omega/^\circ\text{C}$.

Also, the physically small size and low thermal mass of a thermistor bead allows a very fast response to temperature changes.

Another advantage of the thermistor is its relatively high resistance. Thermistors are available with base resistances (at 25°C) ranging from hundreds to millions of ohms. This high resistance diminishes the effect of inherent resistances in the lead wires, which can cause significant errors with low resistance devices such as RTDs. For example, while RTD measurements typically require 3- or 4-wire connections to reduce errors caused by lead-wire resistances, 2-wire connections to thermistors are usually adequate.

The major trade-off for the high resistance and sensitivity of the thermistor is its highly nonlinear output and relatively limited operating range. Depending on the type of thermistor, the upper range is typically limited to around 300°C . Figure 4-4 shows the resistance-temperature curve for a 2,252 Ω thermistor. The curve of a 100 Ω RTD is also shown for comparison.

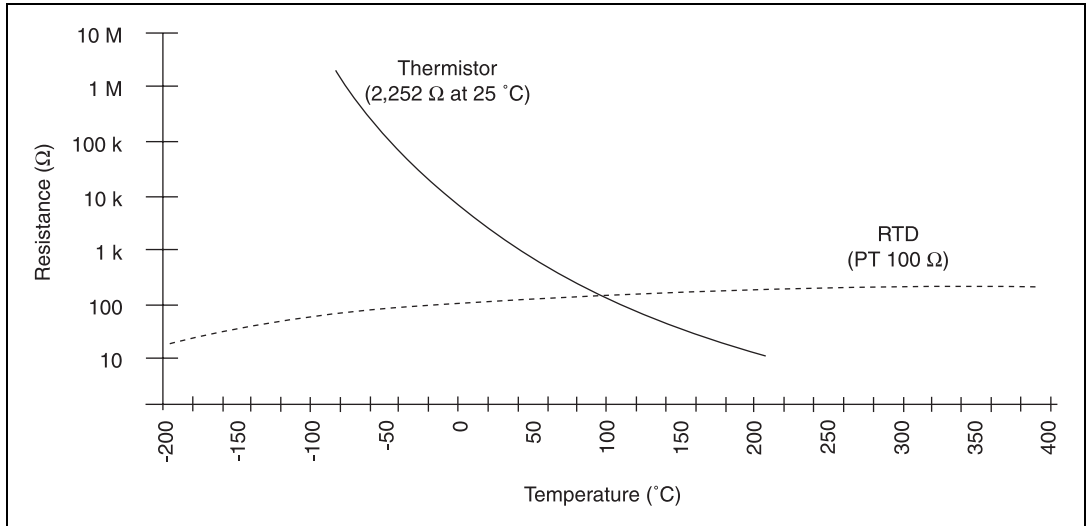

Figure 4-4. Resistance-Temperature Curve for a 2,252 Ω Thermistor

The thermistor has been used primarily for high-resolution measurements over limited temperature ranges. However, continuing improvements in thermistor stability, accuracy, and interchangeability have prompted increased use of thermistors in a variety of applications.

Thermistor Measurement Circuits

This section details information about thermistor measurement circuits. The most common technique is to use a current-source, and measure the voltage developed across the thermistor. Figure shows the measured voltage V_0 equals $R_T \times I_{EX}$.

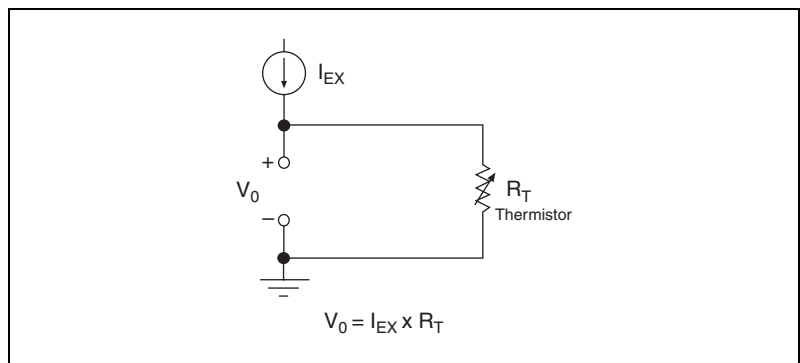

Figure 4-5. Thermistor Measurement with Constant Current Excitation

The maximum resistance of the thermistor is determined from the current excitation value and the maximum voltage range of the input device. When using the SCXI-1503, the maximum measurable resistance is 100 k Ω .

The level of the voltage output signal depends directly on the thermistor resistance and magnitude of the current excitation. Do *not* use a higher level of current excitation in order to produce a higher level output signal because the current causes the thermistor to heat internally, leading to temperature-measurement errors. This phenomena is called self-heating. When current passes through the thermistor, power dissipated by the thermistor equaling ($I_{EX}^2 R_T$), heats the thermistor.

Thermistors, with their small size and high resistance, are particularly prone to these self-heating errors. Manufacturers typically specify this self-heating as a dissipation constant, which is the power required to heat the thermistor 1 $^{\circ}\text{C}$ from ambient temperature (mW/ $^{\circ}\text{C}$). The dissipation constant depends heavily on how easily heat is transferred away from the thermistor, so the dissipation constant can be specified for different media—in still air, water, or oil bath. Typical dissipation constants range anywhere from less than 0.5 mW/ $^{\circ}\text{C}$ for still air to 10 mW/ $^{\circ}\text{C}$ or higher for a thermistor immersed in water. A 2,252 Ω thermistor powered by a 100 μA excitation current dissipates:

$$I^2 R = 100 \mu\text{A}^2 \times 2,252 \Omega = 0.0225 \text{ mW}$$

If this thermistor has a dissipation constant of 10 mW/ $^{\circ}\text{C}$, the thermistor self-heats 0.00225 $^{\circ}\text{C}$ so the self-heating from the 100 μA source of the SCXI-1503 is negligible for most applications. It is still important to carefully read self-heating specifications of the thermistors.

Resistance/Temperature Characteristic of Thermistors

The resistance-temperature behavior of thermistors is highly dependent upon the manufacturing process. Therefore, thermistor curves are not standardized to the extent that thermocouple or RTD curves are standardized. Typically, thermistor manufacturers supply the resistance-versus-temperature curves or tables for their particular devices. You can, however, approximate the thermistor curve relatively accurately with the Steinhart-Hart equation:

$$T(^{\circ}\text{K}) = \frac{1}{a + b[\ln(R_T)] + c[\ln(R_T)]^3}$$

where

$T(^{\circ}\text{K})$ is the temperature in degrees Kelvin, equal to $T(^{\circ}\text{C}) + 273.15$.

R_T is the resistance of the thermistor.

a, b, and c are coefficients obtained from the thermistor manufacturer or calculated from the resistance-versus-temperature curve.

Using the SCXI-1503

This chapter makes suggestions for developing your application and provides basic information regarding calibration.

Developing Your Application in NI-DAQmx



Note If you are not using an NI ADE, using an NI ADE prior to version 8.1, or are using an unlicensed copy of an NI ADE, additional dialog boxes from the NI License Manager appear allowing you to create a task or global channel in unlicensed mode. These messages continue to appear until you install version 8.1 or later of an NI ADE.

This section describes how to configure and use NI-DAQmx to control the SCXI-1503 in LabVIEW, LabWindows/CVI, and Measurement Studio. These ADEs provide greater flexibility and access to more settings than MAX, but you can use ADEs in conjunction with MAX to quickly create a customized application.

Typical Program Flowchart

Figure 5-1 shows a typical program voltage measurement flowchart for creating a task to configure channels, take a measurement, analyze the data, present the data, stop the measurement, and clear the task.

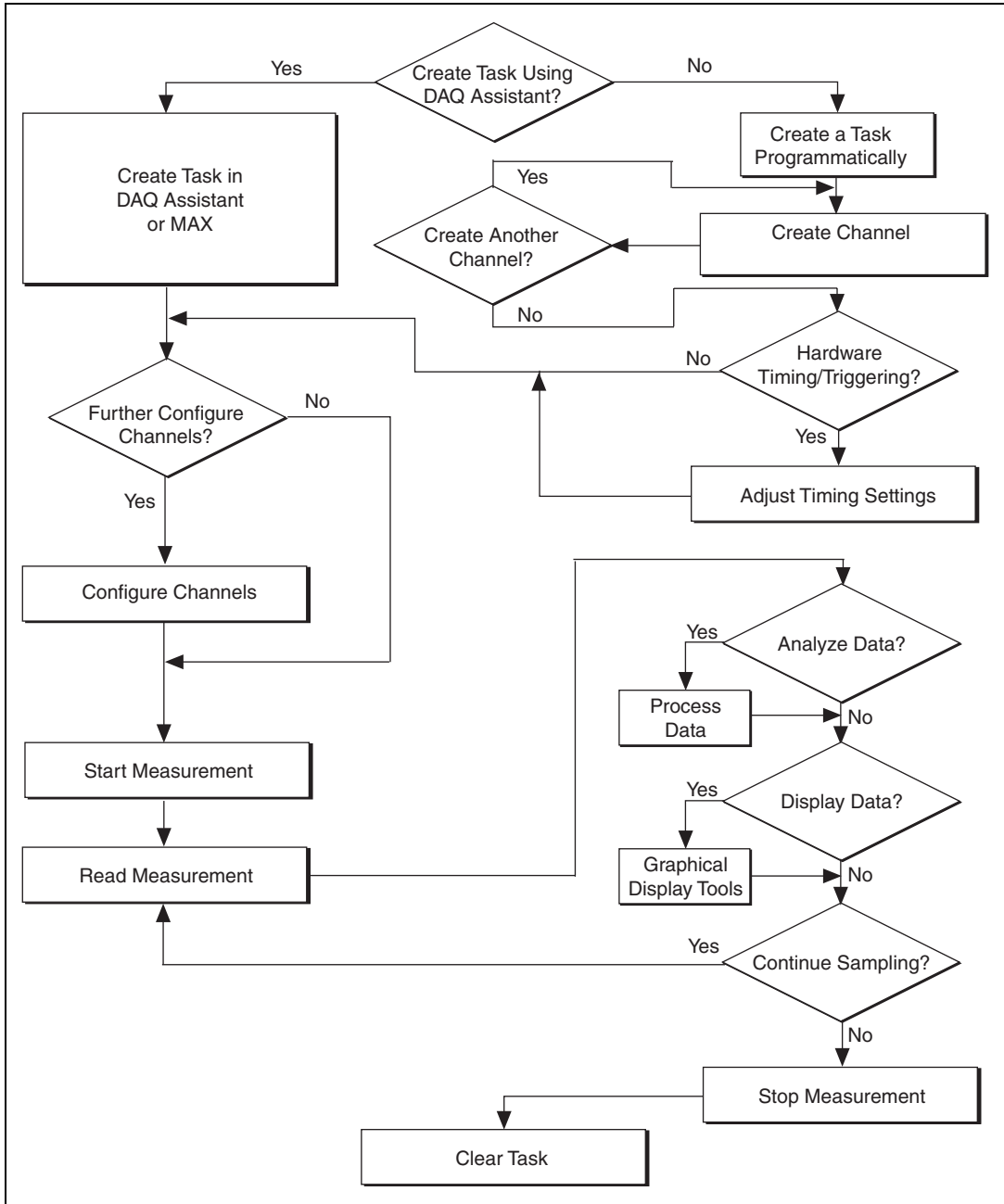

Figure 5-1. Typical Program Flowchart for Voltage Measurement Channels

General Discussion of Typical Flowchart

The following sections briefly discuss some considerations for a few of the steps in Figure 5-1. These sections are meant to give an overview of some of the options and features available when programming with NI-DAQmx.

Creating a Task Using DAQ Assistant or Programmatically

When creating an application, you must first decide whether to create the appropriate task using the DAQ Assistant or programmatically in the ADE.

Developing your application using DAQ Assistant gives you the ability to configure most settings such as measurement type, selection of channels, excitation voltage, signal input limits, task timing, and task triggering. You can access the DAQ Assistant through MAX or your NI ADE. Choosing to use the DAQ Assistant can simplify the development of your application. NI recommends creating tasks using the DAQ Assistant for ease of use, when using a sensor that requires complex scaling, or when many properties differ between channels in the same task.

If you are using an ADE other than an NI ADE, or if you want to explicitly create and configure a task for a certain type of acquisition, you can programmatically create the task from your ADE using functions or VIs. If you create a task using the DAQ Assistant, you can still further configure the individual properties of the task programmatically with functions or property nodes in your ADE. NI recommends creating a task programmatically if you need explicit control of programmatically adjustable properties of the DAQ system.

Programmatically adjusting properties for a task created in the DAQ Assistant overrides the original, or default, settings only for that session. The changes are not saved to the task configuration. The next time you load the task, the task uses the settings originally configured in the DAQ Assistant.

Adjusting Timing and Triggering

There are several timing properties that you can configure through the DAQ Assistant or programmatically using function calls or property nodes. If you create a task in the DAQ Assistant, you can still modify the timing properties of the task programmatically in your application.

When programmatically adjusting timing settings, you can set the task to acquire continuously, acquire a buffer of samples, or acquire one point at a

time. For continuous acquisition, you must use a while loop around the acquisition components even if you configured the task for continuous acquisition using MAX or the DAQ Assistant. For continuous and buffered acquisitions, you can set the acquisition rate and the number of samples to read in the DAQ Assistant or programmatically in your application. By default, the clock settings are automatically set by an internal clock based on the requested sample rate. You also can select advanced features such as clock settings that specify an external clock source, internal routing of the clock source, or select the active edge of the clock signal.

Configuring Channel Properties

All ADEs used to configure the SCXI-1503 access an underlying set of NI-DAQmx properties. Table 5-1 shows some of these properties. You can use Table 5-1 to determine what kind of properties you need to set to configure the module for your application. For a complete list of NI-DAQmx properties, refer to your ADE help file.



Note You cannot adjust some properties while a task is running. For these properties, you must stop the task, make the adjustment, and re-start the application. Tables 5-1 through 5-3 assume all properties are configured before the task is started.

Table 5-1. NI-DAQmx Voltage Measurement Properties

Property	Short Name	Description	DAQ Assistant Accessible
Analog Input»Maximum Value	AI.Max	Specifies the maximum value you expect to measure. The SCXI-1503 gain and E/M Series DAQ device range are computed automatically from this value.	Yes
Analog Input»Minimum Value	AI.Min	Specifies the minimum value you expect to measure. The SCXI-1503 gain and E/M Series DAQ device range are computed automatically from this value.	Yes

Table 5-1. NI-DAQmx Voltage Measurement Properties (Continued)

Property	Short Name	Description	DAQ Assistant Accessible
Analog Input»General Properties»Advanced»Gain and Offset»Gain Value	AI.Gain	Specifies a gain factor to apply to the signal conditioning portion of the channel. The SCXI-1503 supports 1 or 100.	No
Analog Input»General Properties»Advanced»High Accuracy Settings»Auto Zero Mode	AI.AutoZeroMode	Specifies when to measure ground. NI-DAQmx subtracts the measured ground voltage from every sample. The SCXI-1503 supports None or Once.	Yes
Analog Input»General Properties»Advanced»Input Configuration»Coupling	AI.Coupling	Specifies the input coupling of the channel. The SCXI-1503 supports DC and GND coupling.	No

Table 5-2. NI-DAQmx RTD Measurement Properties

Property	Short Name	Description	DAQ Assistant Accessible
Analog Input»Temperature»RTD»Type	AI.RTD.Type	Specifies the type of RTD connected to the channel.	Yes
Analog Input»Temperature»RTD»R0	AI.RTD.R0	Specifies the resistance in ohms of the sensor at 0 °C.	Yes

Table 5-2. NI-DAQmx RTD Measurement Properties (Continued)

Property	Short Name	Description	DAQ Assistant Accessible
Analog Input»Temperature»RTD»Custom»A, B, C	AI.RTD.A AI.RTD.B AI.RTD.C	Specifies the A, B, or C constant of the Callendar-Van Dusen equation when using a custom RTD type.	Yes
Analog Input»General Properties»Signal Conditioning»Resistance Configuration	AI.Resistance.Cfg	Specifies the resistance configuration for the channel, such as 2-wire, 3-wire, or 4-wire.	Yes

Table 5-3. NI-DAQmx Thermistor Measurement Properties

Property	Short Name	Description	DAQ Assistant Accessible
Analog Input»Temperature»Thermistor»R1	AI.Thrmistr.R1	Specifies the resistance in ohms of the sensor at 0 °C.	Yes
Analog Input»Temperature»Thermistor»Custom»A, B, C	AI.Thrmistr.A AI.Thrmistr.B AI.Thrmistr.C	Specifies the A, B, or C constant of the Steinhart-Hart thermistor equation, which NI-DAQmx uses to scale thermistors.	Yes

Table 5-4. NI-DAQmx Thermocouple Measurement Properties

Property	Short Name	Description	DAQ Assistant Accessible
Analog Input»Temperature» Thermocouple»Type	AI.Thermcpl.Type	Specifies the type of thermocouple connected to the channel.	Yes
Analog Input»Temperature» Thermocouple»CJC Source	AI.Thermcpl.CJC Src	Indicates the source of cold-junction compensation.	Yes
Analog Input»Temperature» Thermocouple»CJC Value	AI.Thermcpl.CJCVal	Specifies the temperature of the cold-junction if the CJC source is constant value.	Yes
Analog Input»Temperature» Thermocouple»CJC Channel	AI.Thermcpl.CJCChan	Indicates the channel that acquires the temperature of the cold junction if CJC is channel.	Yes



Note This is *not* a complete list of NI-DAQmx properties and does not include every property you may need to configure your application. It is a representative sample of important properties to configure for voltage measurements. For a complete list of NI-DAQmx properties and more information about NI-DAQmx properties, refer to your ADE help file.

Acquiring, Analyzing, and Presenting

After configuring the task and channels, you can start the acquisition, read measurements, analyze the data returned, and display it according to the needs of your application. Typical methods of analysis include digital filtering, averaging data, performing harmonic analysis, applying a custom scale, or adjusting measurements mathematically.

NI provides powerful analysis toolsets for each NI ADE to help you perform advanced analysis on the data without requiring you to have a programming background. After you acquire the data and perform any required analysis, it is useful to display the data in a graphical form or log it to a file. NI ADEs provide easy-to-use tools for graphical display, such as

charts, graphs, slide controls, and gauge indicators. NI ADEs have tools that allow you to easily save the data to files such as spread sheets for easy viewing, ASCII files for universality, or binary files for smaller file sizes.

Completing the Application

After you have completed the measurement, analysis, and presentation of the data, it is important to stop and clear the task. This releases any memory used by the task and frees up the DAQ hardware for use in another task.



Note In LabVIEW, tasks are automatically cleared.

Developing an Application Using LabVIEW

This section describes in more detail the steps shown in the typical program flowchart in Figure 5-1, such as how to create a task in LabVIEW and configure the channels of the SCXI-1503. If you need more information or for further instructions, select **Help»VI, Function, & How-To Help** from the LabVIEW menu bar.



Note Except where otherwise stated, the VIs in Table 5-5 are located on the **Functions»All Functions»NI Measurements»DAQmx - Data Acquisition** subpalette and accompanying subpalettes in LabVIEW.

Table 5-5. Programming a Task in LabVIEW

Flowchart Step	VI or Program Step
Create Task in DAQ Assistant	Create a DAQmx Task Name Control located on the Controls»All Controls»I/O»DAQmx Name Controls subpalette, right-click it, and select New Task (DAQ Assistant).
Create a Task Programmatically (optional)	DAQmx Create Task.vi located on the Functions»All Functions»NI Measurements»DAQmx - Data Acquisition»DAQmx Advanced Task Options subpalette—This VI is optional if you created and configured the task using the DAQ Assistant. However, if you use it in LabVIEW, any changes you make to the task are not saved to a task in MAX.

Table 5-5. Programming a Task in LabVIEW (Continued)

Flowchart Step	VI or Program Step
Create Virtual Channel(s)	DAQMX Create Virtual Channel.vi located on the Functions»All Functions»NI Measurements»DAQmx - Data Acquisition subpalette—Use this VI to add virtual channels to the task. Select the type of virtual channel based on the measurement you plan to perform.
Adjust Timing Settings (optional)	DAQmx Timing.vi (Sample Clock by default)—This VI is optional if you created and configured the task using the DAQ Assistant. Any timing settings modified with this VI are not saved in the DAQ Assistant. They are only available for the present session.
Configure Channels (optional)	NI-DAQmx Channel Property Node, refer to the Using a NI-DAQmx Channel Property Node in LabVIEW section for more information. This step is optional if you created and fully configured the channels using the DAQ Assistant. Any channel modifications made with a channel property node are not saved in the task in the DAQ Assistant. They are only available for the present session.
Start Measurement	DAQmx Start Task.vi
Read Measurement	DAQmx Read.vi
Analyze Data	Some examples of data analysis include filtering, scaling, harmonic analysis, or level checking. Some data analysis tools are located on the Functions»Signal Analysis subpalette and on the Functions»All Functions»Analyze subpalette.
Display Data	You can use graphical tools such as charts, gauges, and graphs to display the data. Some display tools are located on the Controls»All Controls»Numeric»Numeric Indicator subpalette and Controls»All Controls»Graph subpalette.
Continue Sampling	For continuous sampling, use a While Loop. If you are using hardware timing, you also need to set the DAQmx Timing.vi sample mode to Continuous Samples. To do this, right-click the terminal of the DAQmx Timing.vi labeled sample mode and click Create»Constant . Click the box that appears and select Continuous Samples .

Table 5-5. Programming a Task in LabVIEW (Continued)

Flowchart Step	VI or Program Step
Stop Measurement	DAQmx Stop Task.vi (This VI is optional, clearing the task automatically stops the task.)
Clear Task	DAQmx Clear Task.vi

Using a NI-DAQmx Channel Property Node in LabVIEW

You can use property nodes in LabVIEW to manually configure the channels. To create a LabVIEW property node, complete the following steps:

1. Launch LabVIEW.
2. Create the property node in a new VI or in an existing VI.
3. Open the block diagram view.
4. From the **Functions** toolbox, select **All Functions»NI Measurements»DAQmx - Data Acquisition**, and select **DAQmx Channel Property Node**.
5. The **ActiveChans** property is displayed by default. This allows you to specify exactly what channel(s) you want to configure. If you want to configure several channels with different properties, separate the lists of properties with another **Active Channels** box and assign the appropriate channel to each list of properties.



Note If you do not use Active Channels, the properties are set on all of the channels in the task.

6. Right-click **ActiveChans**, and select **Add Element**. Left-click the new **ActiveChans** box. Navigate through the menus, and select the property you wish to define.
7. Change the property to read or write to either get the property or write a new value. Right-click the property, go to **Change To**, and select **Write, Read, or Default Value**.
8. After you have added the property to the property node, right-click the terminal to change the attributes of the property, add a control, constant, or indicator.
9. To add another property to the property node, right-click an existing property and left-click **Add Element**. To change the new property, left-click it and select the property you wish to define.



Note Refer to the *LabVIEW Help* for information about property nodes and specific NI-DAQmx properties.

Specifying Channel Strings in NI-DAQmx

Use the channel input of **DAQmx Create Channel** to specify the SCXI-1503 channels. The input control/constant has a pull-down menu showing all available external channels. The strings take one of the following forms:

- single device identifier/channel number—for example `SC1Mod1/ai0`
- multiple, noncontinuous channels—for example `SC1Mod1/ai0, SC1Mod1/ai4`.
- multiple continuous channels—for example `SC1Mod1/ai0:4` (channels 0 through 4)

When you have a task containing SCXI-1503 channels, you can set the properties of the channels programmatically using the **DAQmx Channel Property Node**.

Text Based ADEs

You can use text based ADEs such as LabWindows/CVI, Measurement Studio, Visual Basic 6, .NET, and C# to create code for using the SCXI-1503.

LabWindows/CVI

LabWindows/CVI works with the **DAQ Assistant** in MAX to generate code for an voltage measurement task. You can then use the appropriate function call to modify the task. To create a configurable channel or task in LabWindows/CVI, complete the following steps:

1. Launch LabWindows/CVI.
2. Open a new or existing project.
3. From the menu bar, select **Tools>Create/Edit DAQmx Tasks**.
4. Choose **Create New Task In MAX** or **Create New Task In Project** to load the DAQ Assistant.
5. The DAQ Assistant creates the code for the task based on the parameters you define in MAX and the device defaults. To change a property of the channel programmatically, use the `DAQmxSetChanAttribute` function.



Note Refer to the *NI LabWindows/CVI Help* for more information on creating NI-DAQmx tasks in LabWindows/CVI and NI-DAQmx property information.

Measurement Studio (Visual Basic 6, .NET, and C#)

When creating an voltage measurement task in Visual Basic 6, .NET and C#, follow the general programming flow in Figure 5-1. You can then use the appropriate function calls to modify the task. This example creates a new task and configures an NI-DAQmx voltage measurement channel on the SCXI-1503. You can use the same functions for Visual Basic 6, .NET and C#.

The following text is a function prototype example:

```
void AIChannelCollection.CreateVoltageChannel(
    System.String physicalChannelName,
    System.String nameToAssignChannel,
    System.Double minVal,
    System.Double maxVal);
```

To actually create and configure the channel, you would enter something resembling the following example code:

```
Task myTask = new
NationalInstruments.DAQmx.Task("myTaskName");
MyTask.DAQmxCreateAIVoltageChan (
    "SC1Mod1/ai0", // System.String physicalChannelName
    "Voltage0", // System.String nameToAssignChannel
    -10.0, // System.Double minVal
    10.0); // System.Double maxVal
// setting attributes after the channel is created
AIChannel myChannel = myTask.AIChannels["Voltage0"];
myChannel.AutoZeroMode = kAutoZeroTypeOnce;
```

Modify the example code above or the code from one of the shipping examples as needed to suit your application.



Note You can create and configure the voltage measurement task in MAX and load it into your application with the function call
NationalInstruments.DAQmx.DaqSystem.Local.LoadTask.

Refer to the *NI Measurement Studio Help* for more information on creating NI-DAQmx tasks in LabWindows/CVI and NI-DAQmx property information.

Programmable NI-DAQmx Properties

All of the different ADEs that configure the SCXI-1503 access an underlying set of NI-DAQmx properties. Tables 5-1 through 5-4 provide a list of some of the properties that configure the SCXI-1503. You can use this list to determine what kind of properties you need to set to configure the device for your application. For a complete list of NI-DAQmx properties, refer to your ADE help file.



Note Tables 5-1 through 5-4 are *not* complete lists of NI-DAQmx properties and do not include every property you may need to configure voltage measurements. It is a representative sample of important properties to configure voltage measurements. For a complete list of NI-DAQmx properties and more information on NI-DAQmx properties, refer to your ADE help file.

Calibration

The SCXI-1503 is shipped with a calibration certificate and is calibrated at the factory to the specifications described in Appendix A, *Specifications*. Calibration constants are stored inside the calibration EEPROM and provide software correction values your application development software uses to correct the measurements for both offset and gain errors in the module.

Internal/Self-Calibration

You can self-calibrate the SCXI-1503 in MAX by right-clicking the module and selecting Self Calibrate. The NI-DAQmx Self Calibrate Device function does the same. A self-calibration of the SCXI-1503 grounds all the input channels and stores the resulting measurement as an offset correction constant on the module. You should perform a self-calibration every time you install the SCXI-1503 to a new system.



Note You should self-calibrate the connected DAQ device before self-calibrating the SCXI-1503.

External Calibration

If you have an accurate calibrator and DMM, you can externally calibrate the SCXI-1503 gain and offset constants using NI-DAQmx functions. You can also calibrate the 100 μ A current excitation.

The functions that are required for externally calibrating the SCXI-1503 are available in NI-DAQmx 8.1 or later. Refer to the *NI-DAQmx Help* for details about these functions.

Most external calibration documents for SCXI modules are available to download from ni.com/calibration by clicking **Manual Calibration Procedures**. For external calibration of modules not listed there, Basic Calibration Service or Detailed Calibration Service is recommended. You can get information about both of these calibration services from ni.com/calibration. NI recommends performing an external calibration once a year.



Note Performing an external calibration of the SCXI-1503 permanently overwrites the factory calibration settings, which impacts the accuracy of the inputs.

Specifications

This appendix lists the specifications for the SCXI-1503 modules. These specifications are typical at 25 °C unless otherwise noted.

Analog Input

Input Characteristics

Number of channels	16 differential
Input coupling	DC
Input signal ranges	± 100 mV (gain = 100) or ± 10 V (gain = 1)
Input overvoltage protection	
Powered on	± 42 VDC
Powered off	± 25 V
Inputs protected	AI<0..15>
CJ sensor input protection	± 15 VDC powered on or off

Transfer Characteristics

Nonlinearity	0.005% FSR
Input offset error (RTI)	
Gain = 1	
Calibrated ¹	± 650 μ V max ± 250 μ V typ
With autozero enabled ²	± 300 μ V max ± 150 μ V typ

¹ Assumes 1,000 point average, 25 °C ± 10 °C over one year.

² Assumes 1,000 point average, ± 1 °C of autozero temperature.

Gain = 100

Calibrated¹±25 µV max
 ±10 µV typ

With autozero enabled²±10 µV max
 ±5 µV typ

Gain error (relative to calibration reference)

Gain = 1 or 100

Calibrated¹0.074% of reading max
 0.02% of reading typ

RTD Measurement Accuracy

Table A-1. RTD Measurement Accuracy

Measured Temperature °C	100 Ω Max °C	100 Ω Typ °C	1000 Ω Max °C	1000 Ω Typ °C
-100 to 0	0.60	0.23	1.09	0.46
0 to 25	0.62	0.23	1.11	0.47
25 to 100	0.69	0.25	1.20	0.49
100 to 500	1.11	0.37	1.68	0.65
500 to 1200	2.06	0.65	2.81	1.04

Notes: The accuracies in this table reflect using the module in 4-wire mode. They do not include errors from the RTD including lead-wire errors when using 2- or 3-wire connection.

The accuracies assume auto-zero is enabled and the environmental conditions are 25 °C ±10 °C over a one year period.

These accuracies were computed using a standard RTD with a TCR of 3851.

Amplifier Characteristics

Input couplingDC

Input impedance

Normal powered on>1 GΩ

Input bias current±2.8 nA

¹ Assumes 1,000 point average, 25 °C ±10 °C over one year.

² Assumes 1,000 point average, ±1 °C of autozero temperature.

CMRR characteristics (DC to 60 Hz)

Gain 1	-75 dB min -90 dB typ
Gain 100.....	-106 dB min -110 dB typ

Output range..... ± 10 VOutput impedance 91Ω **Dynamic Characteristics**

Minimum scan interval (per channel, any gain)

$\pm 0.012\%$ accuracy.....	3 μ s
$\pm 0.0061\%$ accuracy.....	10 μ s
$\pm 0.0015\%$ accuracy.....	20 μ s

Noise characteristics (RTI)

Gain = 1	
10 Hz to 1 MHz	100 μ V _{rms}
Gain = 100	
10 Hz to 1 MHz	1 μ V _{rms}
0.1 to 10 Hz.....	0.5 μ V _{p-p}

Filter

Cutoff frequency (-3 dB)..... 5 Hz

NMR (60 Hz) -40 dB min

Step response characteristics (gain 1 or 100)

To 0.0015%..... 0.6 s

Stability

Recommended warm-up time 20 min

Offset temperature coefficient

Gain = 1	$\pm 35 \mu$ V/ $^{\circ}$ C max $\pm 10 \mu$ V/ $^{\circ}$ C typ
Gain = 100	$\pm 1.5 \mu$ V/ $^{\circ}$ C max $\pm 0.5 \mu$ V/ $^{\circ}$ C typ

Gain temperature coefficient
(gain 1 or 100) ± 15 ppm/ $^{\circ}\text{C}$ max
 ± 5 ppm/ $^{\circ}\text{C}$ typ

Excitation

Channels 16 single-ended outputs
Current output 100 μA
Accuracy $\pm 0.05\%$
Temperature drift ± 5 ppm/ $^{\circ}\text{C}$
Output voltage compliance 10 V
Maximum resistive load 100 k Ω
Overvoltage protection ± 40 VDC
Measurement Category CAT I

Power Requirements From SCXI Backplane

V+ 18.5 to 25 VDC, 170 mA
V- -18.5 to -25 VDC, -170 mA
+5 V +4.75 to 5.25 VDC, 50 mA

Environmental

Operating temperature 0 to 50 $^{\circ}\text{C}$
Storage temperature -20 to 70 $^{\circ}\text{C}$
Humidity 10 to 90% RH, noncondensing
Maximum altitude 2,000 meters
Pollution Degree (indoor use only) 2

Physical

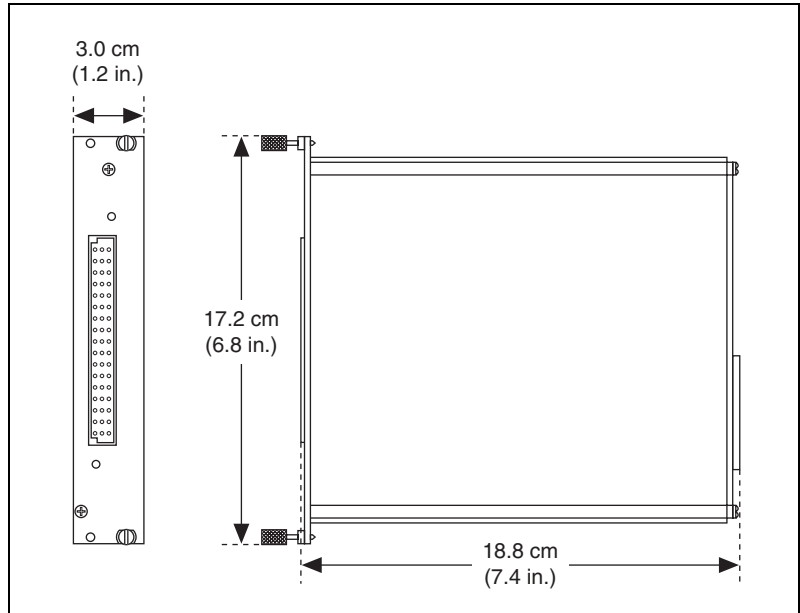

Figure A-1. SCXI-1503 Dimensions

Weight..... 745 g (26.3 oz)

Maximum Working Voltage

Maximum working voltage refers to the signal voltage plus the common-mode voltage.

Signal + common mode Each input should remain within ± 10 V of AI GND

Safety

This product is designed to meet the requirements of the following standards of safety for electrical equipment for measurement, control, and laboratory use:

- IEC 61010-1, EN-61010-1
- UL 61010-1, CSA 61010-1



Note For UL and other safety certifications, refer to the product label or visit ni.com/certification, search by model number or product line, and click the appropriate link in the Certification column.

Electromagnetic Compatibility

This product is designed to meet the requirements of the following standards of EMC for electrical equipment for measurement, control, and laboratory use:

- EN 61326 EMC requirements; Minimum Immunity
- EN 55011 Emissions; Group 1, Class A
- CE, C-Tick, ICES, and FCC Part 15 Emissions; Class A



Note For EMC compliance, operate this device according to product documentation.

CE Compliance

This product meets the essential requirements of applicable European Directives, as amended for CE marking, as follows:

- 73/23/EEC; Low-Voltage Directive (safety)
- 89/336/EEC; Electromagnetic Compatibility Directive (EMC)



Note Refer to the Declaration of Conformity (DoC) for this product for any additional regulatory compliance information. To obtain the DoC for this product, visit ni.com/certification, search by model number or product line, and click the appropriate link in the Certification column.

Waste Electrical and Electronic Equipment (WEEE)



EU Customers At the end of their life cycle, all products *must* be sent to a WEEE recycling center. For more information about WEEE recycling centers and National Instruments WEEE initiatives, visit ni.com/environment/weee.htm.

Removing the SCXI-1503

This appendix explains how to remove the SCXI-1503 from MAX and an SCXI chassis or PXI/SCXI combination chassis.

Removing the SCXI-1503 from MAX

To remove a module from MAX, complete the following steps after launching MAX:

1. Expand **Devices and Interfaces**.
2. Click the + next to **NI-DAQmx** to expand the list of installed chassis.
3. Click the + next to the appropriate chassis to expand the list of installed modules.
4. Right-click the module or chassis you want to delete and click **Delete**.
5. A confirmation window opens. Click **Yes** to continue deleting the module or chassis or **No** to cancel this action.



Note Deleting the SCXI chassis deletes all modules in the chassis. All configuration information for these modules is also lost.

The SCXI chassis and/or SCXI module(s) should now be removed from the list of installed devices in MAX.

Removing the SCXI-1503 from a Chassis

Consult the documentation for the chassis and accessories for additional instructions and precautions. To remove the SCXI-1503 module from a chassis, complete the following steps while referring to Figure B-1:

1. Power off the chassis. Do *not* remove the SCXI-1503 module from a chassis that is powered on.
2. If the SCXI-1503 is the module cabled to the E/M Series DAQ device, disconnect the cable.
3. Remove any terminal block that connects to the SCXI-1503.

4. Rotate the thumbscrews that secure the SCXI-1503 to the chassis counterclockwise until they are loose, but do not completely remove the thumbscrews.

Remove the SCXI-1503 by pulling steadily on both thumbscrews until the module slides completely out.

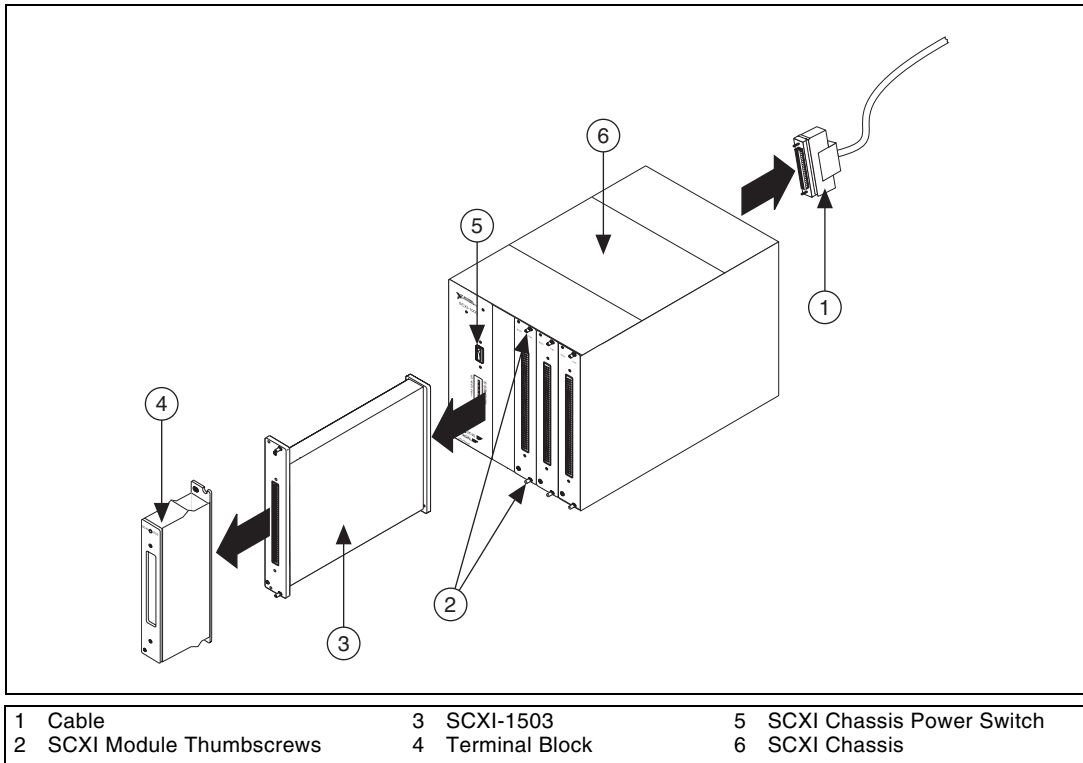

Figure B-1. Removing the SCXI-1503



Common Questions

This appendix lists common questions related to the use of the SCXI-1503.

Which version of NI-DAQ works with the SCXI-1503, and how do I get the most current version of NI-DAQ?

You must have NI-DAQ 8.1 or later. Visit the NI Web site at ni.com and select **Download Software»Drivers and Updates»Search Drivers and Updates**. Enter the keyword NI-DAQ to find the latest version of NI-DAQ for your operating system.

I cannot correctly test and verify that my SCXI-1503 is working. What should I do?

Unfortunately, there is always the chance that one or more components in the system are not operating correctly. You may have to call or email a technical support representative. The technical support representative often suggests troubleshooting measures. If requesting technical support by phone, have the system nearby so you can try these measures immediately. NI contact information is listed in the *Technical Support Information* document.

Can the SCXI-1503 current outputs be interactively controlled in MAX or programmatically controlled using NI-DAQ function calls, LabVIEW, or Measurement Studio?

No. The current-output level is 100 μ A as long as the chassis is powered on. You cannot power off or adjust the current output using MAX, NI-DAQ function calls, or an ADE such as LabVIEW or Measurement Studio. If you require this functionality, consider using an SCXI-1124 module or NI 670X device instead.

How can I ground a floating voltage measurement?

You can use the IEX– terminal of each channel as a ground reference. Refer to the *SCXI-1306 Terminal Block Installation Guide* for details about using the SCXI-1306 DIP switches to control ground referencing.

Can I connect N current-output channels in parallel to create a precision current source that provides $N \times 100 \mu\text{A}$?

Yes, you can connect the current output in parallel. When connecting the output in parallel, connect the appropriate IEX+ terminals together and the corresponding IEX- terminals together.

Can I connect N current-output channels in series to achieve a higher terminal-voltage compliance limit?

No. Each current source is ground referenced. Therefore, you cannot place multiple current-outputs in series.

Are the SCXI-1503 channels isolated with respect to each other, the E/M Series DAQ device, or ground?

No. The SCXI-1503 does not contain any isolation circuitry. If you require isolation, consider the SCXI-1124 or SCXI-1125 module instead.

Can I modify the SCXI-1503 circuitry to generate current at a level different than $100 \mu\text{A}$?

No. Do not attempt to modify any circuitry in the SCXI-1503.

Are there any user-serviceable parts inside the SCXI-1503?

No. There are no fuses, potentiometers, switches, socketed resistors, or jumpers inside the module. Disassembly of the module for any reason can void its warranty and nullify its accuracy specification.

Can I access the unused analog-input channels of the E/M Series DAQ device if it is directly cabled to the SCXI-1503 in a single-chassis system?

Yes. E/M Series DAQ device channels 1 through 7 are available to measure unconditioned signals. Use an SCXI-1180 or the 50-pin breakout connector on the SCXI-1346 or SCXI-1349 cable adapter to route signals to these channels.

Which digital lines are unavailable on the E/M Series DAQ device if I am cabled to an SCXI-1503 module?

Table 2-4 shows the digital lines that are used by the SCXI-1503 for communication and scanning. These lines are unavailable for general-purpose digital I/O if the SCXI-1503 is connected to the E/M Series DAQ device.

Does short-circuiting a current-output channel do any damage to the SCXI-1503?

No. The SCXI-1503 delivers 100 μA into any load from 0 Ω to 100 k Ω .

Does open-circuiting a current-output channel damage the SCXI-1503? What is the open-circuit voltage level?

No. An SCXI-1503 current-output channel is not damaged if no load is connected. The open-circuit voltage is 12.4 VDC.

Glossary

Symbol	Prefix	Value
μ	micro	10^{-6}
m	milli	10^{-3}
k	kilo	10^3
M	mega	10^6

Numbers/Symbols

%	percent
+	positive of, or plus
-	negative of, or minus
\pm	plus or minus
<	less than
/	per
°	degree
Ω	ohms
+5 V (signal)	+5 VDC source signal

A

A	amperes
ADE	application development environment such as LabVIEW, LabWindows/CVI, Visual Basic, C, and C++
AI	analog input
AI GND	analog input ground signal

B

bit one binary digit, either 0 or 1

C

CE European emissions control standard

C GND chassis ground signal

channel pin or wire lead to which you apply, or from which you read, an analog or digital signal. Analog signals can be single-ended or differential. For digital signals, channels (also known as lines) are grouped to form ports.

chassis the enclosure that houses, powers, and controls SCXI modules

CLK clock input signal

common-mode voltage voltage that appears on both inputs of a differential amplifier

current excitation a source that supplies the current needed by a sensor for its proper operation

D

D/A digital-to-analog

D*/A Data/Address

DAQ data acquisition—(1) collecting and measuring electrical signals from sensors, transducers, and test probes or fixtures and processing the measurement data using a computer; (2) collecting and measuring the same kinds of electrical signals with A/D and/or DIO devices plugged into a computer, and possibly generating control signals with D/A and/or DIO devices in the same computer

DAQ device a data acquisition device. Examples are E/M Series data acquisition devices

DAQ D*/A the data acquisition device data/address line signal used to indicate whether the SER DAT IN pulse train transmitted to the SCXI chassis contains data or address information

device a plug-in data acquisition device, module, card, or pad that can contain multiple channels and conversion devices. SCXI modules are distinct from devices, with the exception of the SCXI-1200, which is a hybrid.

D GND	digital ground signal
differential amplifier	an amplifier with two input terminals, neither of which are tied to a ground reference, whose voltage difference is amplified
DIN	Deutsche Industrie Norme (German Industrial Standard)
DIO	digital input/output
DoC	Declaration of Conformity
drivers/driver software	software that controls a specific hardware device such as an E/M Series DAQ device

E

EMC	electromagnetic compliance
EMI	electromagnetic interference
excitation	a voltage or current source used to energize a sensor or circuit
EXT CLK	external clock signal

G

gain	the factor by which a signal is amplified, sometimes expressed in decibels
------	--

I

ID	identifier
IEX+	positive excitation channel
IEX-	negative excitation channel
in.	inch or inches
input impedance	the measured resistance and capacitance between the input terminals of a circuit

J

jumper a small rectangular device used to connect two adjacent posts on a circuit board. Jumpers are used on some SCXI modules and terminal blocks to either select certain parameters or enable/disable circuit functionality.

L

lead resistance the small resistance of a lead wire. The resistance varies with the lead length and ambient temperature. If the lead wire carries excitation current, this varying resistance can cause measurement error.

M

m meters

M (1) Mega, the standard metric prefix for 1 million or 10^6 , when used with units of measure such as volts and hertz; (2) mega, the prefix for 1,048,576, or 2^{20} , when used with B to quantify data or computer memory

MISO master-in-slave-out signal

MOSI master-out-slave-in signal

multiplex to route one of many input signals to a single output

multiplexed mode an SCXI operating mode in which analog input channels are multiplexed into one module output so that the cabled E/M Series DAQ device has access to the multiplexed output of the module as well as the outputs of all other multiplexed modules in the chassis

N

NC not connected (signal)

NI-DAQ the driver software needed in order to use National Instruments E/M Series DAQ devices and SCXI components

NI-DAQmx The latest NI-DAQ driver with new VIs, functions, and development tools for controlling measurement devices.

O

output voltage compliance the largest voltage that can be generated across the output of a current source without the current going out of specification

OUT REF output reference signal

P

ppm parts per million

PXI PCI eXtensions for Instrumentation—an open specification that builds on the CompactPCI specification by adding instrumentation-specific features

R

R_L lead resistance

RMA Return Material Authorization

RSVD reserved bit, pin, or signal

RTD resistance-temperature detector

S

s seconds

S samples

scan one or more analog samples taken at the same time, or nearly the same time. Typically, the number of input samples in a scan is equal to the number of channels in the input group. For example, one scan, acquires one new sample from every analog input channel in the group.

SCAN CLK scan clock signal used to increment to the next channel after each E/M Series DAQ device analog-to-digital conversion

SCXI Signal Conditioning eXtensions for Instrumentation

SCXIBus located in the rear of an SCXI chassis, the SCXIBus is the backplane that connects modules in the same chassis to each other

sensor	a type of transducer that converts a physical phenomenon into an electrical signal
SER CLK	serial clock signal used to synchronize digital data transfers over the SER DAT IN and SER DAT OUT lines
SER DAT IN	serial data input signal
SER DAT OUT	serial data output signal
signal conditioning	the manipulation of signals to prepare them for digitizing
Slot 0	refers to the power supply and control circuitry in the SCXI chassis
SLOT 0 SEL	slot 0 select signal
SPI CLK	serial peripheral interface clock signal

T

thermistor	a thermally sensitive resistor
Traditional NI-DAQ (Legacy)	An upgrade to the earlier version of NI-DAQ. Traditional NI-DAQ (Legacy) has the same VIs and functions and works the same way as NI-DAQ 6.9.x. You can use both Traditional NI-DAQ (Legacy) and NI-DAQmx on the same computer, which is not possible with NI-DAQ 6.9.x.
transducer	a device capable of converting energy from one form to another

U

UL	Underwriters Laboratory
----	-------------------------

V

V	volts
VAC	volts, alternating current
VDC	volts, direct current

- VI virtual instrument—(1) a combination of hardware and/or software elements, typically used with a PC, that has the functionality of a classic stand-alone instrument; (2) a LabVIEW software module (VI), which consists of a front panel user interface and a block diagram program
- virtual channels channel names that can be defined outside the application and used without having to perform scaling operations

W

- W watts

Index

Numerics

- 2-wire configuration of resistive devices, 2-4
- 3-wire resistive sensor
 - connected in 2-wire configuration, 2-5
 - lead-resistance compensation
 - with two matched current sources, 2-6
- 4-wire configuration of resistive devices, 2-3

A

- adjusting timing and triggering, 5-3
- AI 0 signal, multiplexing, 2-11
- amplifier characteristics specifications, A-2
- analog circuitry
 - analog input channels, 4-3
 - CJ SENSOR, 4-3
- analog input channels, 4-3
- analog input signal connections, 2-1
 - ground-referencing of signals, 2-2
- analog input signals, multiplexed, 4-4
- analog input specifications, A-1
 - amplifier characteristics, A-2
 - dynamic characteristics, A-3
 - input characteristics, A-1
 - transfer characteristics, A-1
- applications
 - developing in NI-DAQmx, 5-1
 - acquiring, analyzing, and presenting, 5-7
 - completing, 5-8
 - LabVIEW, 5-8
 - program flowchart (figure), 5-2
 - programmable properties, 5-13
 - specifying channel strings, 5-11

C

- cables, custom, 2-1
- calibration, SCXI-1503, 5-13
- CE compliance specifications, A-6
- channel properties, configuring, 5-4
- channels, voltage measurement flowchart (figure), 5-2
- circuitry
 - analog, 4-3
 - digital control, 4-3
- CJC source/value, 3-2
- common questions, C-1
- common software-configurable settings
 - CJC source/value, 3-2
 - gain/input range, 3-1
- configuration, 3-1
 - channel properties, 5-4
 - SCXI-1503
 - common software settings, 3-1
 - settings in MAX
 - NI-DAQmx, 3-3
 - creating a global channel or task, 3-3
 - verifying signal, 3-4
 - NI-DAQmx, 3-4
- configuration and testing, 3-1
- configuration settings, gain/input range, 3-1
- configuring channel properties, 5-4
- connecting resistive devices to SCXI-1503, 2-2
 - 2-wire configuration, 2-4
 - 3-wire resistive sensor connected in 2-wire configuration, 2-5
 - 4-wire configuration, 2-3
 - lead-resistance compensation
 - using 3-wire resistive sensor and two matched current sources, 2-6

conventions used in the manual, *iv*
creating a task
 DAQ Assistant, 5-3
 programmatically, 5-3
current output channels, questions
 about, C-1, C-3
current sources, operating, 4-4
custom cables, 2-1

D

DAQ Assistant, creating a task, 5-3
DAQ device
 accessing unused analog input
 channels, C-2
DAQ devices
 unavailable digital lines, C-2
digital control circuitry, 4-3
dynamic characteristics specifications, A-3

E

E/M Series DAQ devices, 4-4
electromagnetic compatibility
 specifications, A-6
environment specifications, A-4
excitation specifications, A-4

F

filters specifications, A-3
front connector
 pin assignments (table), 2-8

G

gain/input range, configuration, 3-1

I

input characteristics specifications, A-1
installation into SCXI chassis, 1-4

L

LabVIEW
 developing an application, 5-8
 programming a task (table), 5-8
 using a NI-DAQmx channel property
 node, 5-10
LabWindows/CVI
 creating code for using SCXI-1503, 5-11

M

maximum working voltage specifications, A-5
Measurement & Automation Explorer
 configurable settings, 3-2
 removing the SCXI-1503, B-1
measurement properties, NI-DAQmx
 RTD (table), 5-5
 thermistor (table), 5-6
 thermocouple (table), 5-7
 voltage (table), 5-4
Measurement Studio
 creating code for using SCXI-1503, 5-12
multiplexed mode operation
 theory, 4-4
multiplexing
 analog input signals, 4-4
 SCXI-1503, 4-4
 with AI 0 signal, 2-11

N

NI-DAQ version required, C-1
NI-DAQmx
 configurable settings, 3-3
 developing applications, 5-1
 acquiring, analyzing, and
 presenting, 5-7
 adjusting timing and triggering, 5-3
 completing, 5-8
 configuring channel properties, 5-4
 LabVIEW, 5-8

- NI-DAQmx channel property node, 5-10
- program flowchart (figure), 5-2
- programmable properties, 5-13
- specifying channel strings, 5-11
- RTD measurement properties (table), 5-5
- thermistor measurement properties (table), 5-6
- thermocouple measurement properties (table), 5-7
- voltage measurement properties (table), 5-4

O

- operation of current sources, 4-4

P

- physical specifications, A-5
- pin assignments
 - front connector (table), 2-8
- power requirements from SCXI backplane, A-4

Q

- questions and answers, C-1

R

- rear signal connector, 4-3
 - descriptions, 2-11
- removing the SCXI-1503
 - from Measurement & Automation Explorer, B-1
- resistive devices, connecting to SCXI-1503
 - 2-wire configuration, 2-4
 - 3-wire resistive sensor connected to
 - 2-wire configuration, 2-5
 - 4-wire configuration, 2-3

- lead-resistance compensation
 - using 3-wire resistive sensor and two matched current sources, 2-6

RTD

- measurement properties (table), 5-5
- RTDs (resistive-temperature detectors)
 - measurement errors, 4-6
 - overview, 4-5
 - relationship between resistance and temperature, 4-6
 - resistance-temperature curve (figure), 4-7

S

- safety specifications, A-6
- SCXI-1503
 - calibration, 5-13
 - common questions, C-1
 - common software settings, 3-1
 - communication signals (table), 2-11
 - configuration settings, 3-1
 - major components, 4-3
 - measurements, 3-3
 - multiplexing, 4-4
 - removing (figure), B-2
 - removing from SCXI chassis, B-1
 - taking measurements. *See* measurements using
 - LabWindows/CVI to create code, 5-11
 - Measurement Studio to create code, 5-12
- SCXIbus
 - connector, 4-3
 - interface, 4-3
- self-test verification, troubleshooting, C-1
- signal connections
 - analog input, 2-1
 - front connector
 - pin assignments (table), 2-8

- signals
 - verifying, 3-4
 - NI-DAQmx, 3-4
 - software, NI-DAQ version required, C-1
 - specifications
 - analog input, A-1
 - CE compliance, A-6
 - electromagnetic compatibility, A-6
 - environment, A-4
 - excitation, A-4
 - filters, A-3
 - maximum working voltage, A-5
 - physical, A-5
 - power requirements from SCXI
 - backplane, A-4
 - safety, A-6
 - stability, A-3
 - specifying channel strings in
 - NI-DAQmx, 5-11
 - stability specifications, A-3
- T**
- taking measurements. *See* measurements
 - temperature measurement with resistive transducers, 4-5
 - connecting resistive devices to
 - SCXI-1503, 2-2
 - 2-wire configuration, 2-4
 - 3-wire resistive sensor connected in
 - 2-wire configuration, 2-5
 - 4-wire configuration, 2-3
 - lead resistance compensation
 - using 3-wire resistive sensor and two matched current sources, 2-6
 - RTDs
 - measurement errors, 4-6
 - overview, 4-5
 - relationship between resistance and temperature, 4-6
 - resistance temperature curve (figure), 4-7
 - thermistors
 - measurement circuits, 4-11
 - overview, 4-10
 - resistance/temperature characteristics, 4-12
 - resistance-temperature curve (figure), 4-11
 - theory of multiplexed operation, 4-4
 - theory of operation
 - analog circuitry, 4-3
 - digital circuitry, 4-3
 - rear signal connector, 4-3
 - SCXIbus connector, 4-3
 - SCXIbus interface, 4-3
 - theory of multiplexed operation, 4-4
 - thermistor, measurement properties (table), 5-6
 - thermistors
 - measurement circuits, 4-11
 - overview, 4-10
 - resistance/temperature characteristics, 4-12
 - resistance-temperature curve (figure), 4-11
 - thermocouple, measurement properties (table), 5-7
 - timing and triggering, adjusting, 5-3
 - transfer characteristics specifications, A-1
 - troubleshooting
 - incorrect test and verification, C-1
- V**
- verifying
 - signal, 3-4
 - NI-DAQmx, 3-4
 - troubleshooting, C-1
 - Visual Basic
 - creating code for the SCXI-1503, 5-11

Free Manuals Download Website

<http://myh66.com>

<http://usermanuals.us>

<http://www.somanuals.com>

<http://www.4manuals.cc>

<http://www.manual-lib.com>

<http://www.404manual.com>

<http://www.luxmanual.com>

<http://aubethermostatmanual.com>

Golf course search by state

<http://golfingnear.com>

Email search by domain

<http://emailbydomain.com>

Auto manuals search

<http://auto.somanuals.com>

TV manuals search

<http://tv.somanuals.com>