

NEC

**MultiSync XG85
MultiSync XG135LC**

**Large Screen MultiSync Projection Monitor
Operation Manual**

Model Number:

XG-852/XG-1352

XG-852G/XG-1352G

For the customers in Germany

CAUTION: To turn off main power, be sure to remove the plug from power outlet. The power outlet socket should be installed as near to the equipment as possible, and should be easily accessible.

3. GSGV Acoustic Noise Information Ordinance:

The sound pressure level is less than 70 dB(A) according to ISO 3744 or ISO 7779.

INTRODUCTION

Before operating this projector, please read this manual carefully and completely. This manual will provide you with the basic instructions for operation of the projector. Installation, preliminary adjustments and procedures which require the opening of the projector and contact with electrical components should be performed by service personnel. For continued safe and reliable operation, use only cables supplied by the manufacturer for power. Adhere to all notes and warnings.

Features

- ▶ Multi scan circuit automatically locks on video, superdata from 15 to 85 kHz (XG85) and graphics signals 15 to 135 kHz (XG135LC).
You can interface video and high resolution RGB signals from various computers, workstations and graphics boards.
- ▶ 8" CRTs with deflection angle 90 degrees produce a detailed picture with a resolution of 2500×2000 (addressable) XG135LC and 1600×1200 (addressable) XG85.
- ▶ Newly developed video output circuit makes possible 110 MHz of Video Bandwidth (XG85) and 150MHz (XG135LC) with 1100 lumens peak light output (XG85) and 1200 lumens (XG135LC).
- ▶ ECP lens produces an image with true color reproduction.
- ▶ AKB circuit provides stable white balance.
- ▶ Display size can be altered to accommodate any picture size from 60" to 300" diagonal. In addition to ceiling mounting, floor, desk top and rear installations are possible. (The ceiling mounting kits can be purchased as an optional item for ceiling installation.)
- ▶ Digital convergence provides high accuracy for projecting fine graphic displays.
- ▶ On-screen menus provide easy access to adjustment items.
- ▶ ISS-6020/ISS-6020G interface allows 100 inputs.
- ▶ Video system compatible with NTSC, PAL, SECAM and NTSC 4.43.
- ▶ Up to 100 sources can be stored in digital memory.
- ▶ Quick copy convergence for fast easy set up from one pre-set signal.
- ▶ Built in self diagnostics for on-sight troubleshooting.
- ▶ Built in test patterns such as "CROSS HAIR", "CROSS HATCH", "DOT", "WINDOW", "ALL WHITE", "GRAY SCALE", and "H (FOCUS)" for accurate setup.
- ▶ Source information status display.
- ▶ The SEQUENCER function allows the projector to automatically select input signals one after another as programmed by the user.
- ▶ Compatible with a component video signal such as DVD.

INTRODUCTION

Important Safeguards

The following are important safety instructions designed to ensure the long life of your projector and to prevent fire and shock hazards. Be sure to read these safety instructions carefully and follow all warnings given below.

Installation

The projector must be installed by trained personnel.

Place the projector on a flat, level surface and in a dry area free from dust and moisture. Do not place the projector in direct sunlight, near stoves or other heat radiating appliances. Smoke, steam and exposure to direct sunlight could adversely affect the internal components. Avoid rough handling when moving your equipment as a strong shock could damage its internal components. If installing the projector on the ceiling, use only optional ceiling kits (two types) supplied by the manufacturer. Observe all instructions and warnings. Since installing the projector on the ceiling requires special techniques and a optional ceiling kit, users must not try to install it. Contact your dealer for ceiling installation. When ordering the ceiling kit, specify the part name, PG CMKIT-F or PG CMKIT.

Power supply

The XG-852 and XG-1352 projector are designed to operate on 120 V 60 Hz, and the XG-852G and XG-1352G are designed to operate on 220-240 V 50 Hz AC power supply. Make sure your local power supply matches these requirements before operation.

Handle the power cord carefully and avoid excessive bending. A damaged cord may cause electric shock or fire. If the projector is not to be used for an extended period, remove the plug from the power outlet.

Cleaning

Unplug the projector from the power outlet before cleaning.

Clean the cabinet and front panel periodically with a soft cloth. If heavily stained, use a mild detergent solution. Never use strong detergents or solvents such as alcohol or thinner to clean your projector.

Lens cleaning: Avoid touching the lens surfaces.

Special coating is applied to the lens surfaces.

Consult your dealer for lens cleaning.

Fire and Shock Precautions

Adequate ventilation must be provided to prevent heat build-up inside the projector. Make sure the ventilation holes are unobstructed.

Keep the inside of the projector free from foreign objects, such as paper clips, nails, paper, etc. Do not attempt to retrieve such objects yourself or insert metal objects such as wire and screw-drivers inside the projector. If a hazardous object falls inside the projector, unplug it immediately and call a qualified electrical repairman for removal.

Do not set liquids on top of the projector.

CONTENTS

PART NAMES AND FUNCTIONS	6
Front Panel	7
Rear Panel	7
Remote Control Unit	8
Battery installation and replacement	9
Remote control cautions	9
Handling remote control and batteries	9
EXAMPLES OF CONNECTIONS	10
Cautions on Connections	10
When Used in Stand Alone Operation	10
When Used with One Switcher (ISS-6020/ISS-6020G)	11
When Used with Two or More Switchers (100 Inputs)	12
REMOTE 1 Terminal	14
BASIC OPERATION	16
Picture Projection	16
Displaying the Menu and Adjustment Screens	17
Storing Projector Settings (Automatic Save Feature)	18
Picture Adjustment	20
Position Adjustment	21
Sound Adjustment	
(only when used with the ISS-6020/ISS-6020G switcher)	23
Input Selection	24
Source Information	26
Static Convergence Adjustment	27
Closed Caption Mode Selection	28
Setting Timer	29
Mute	33
Normal, Load, and Cancel Function	33
Data Area for Output and Storage	34
Searching Registered Signals	35
Screen Format in Projecting a Picture	36
SPECIFICATIONS	37

This manual covers the XG135LC and XG85 projectors.
The operating procedures are common to the two models.

PART NAMES AND FUNCTIONS

Front Terminal Panel

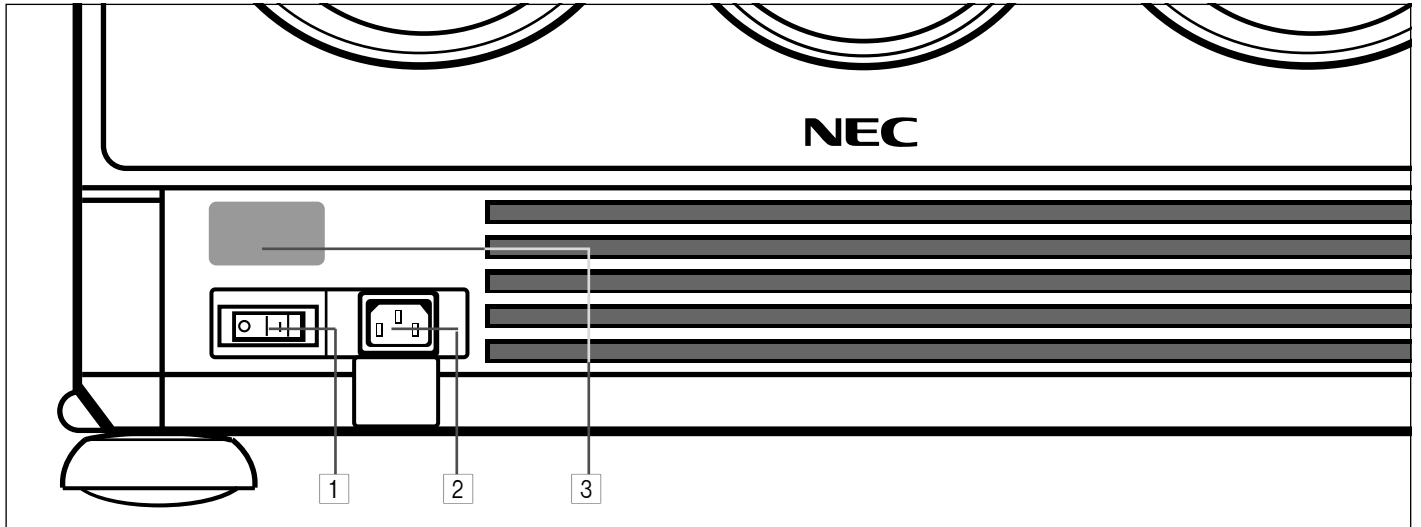

Rear Control Panel

A cover is provided to attach the rear control panel.

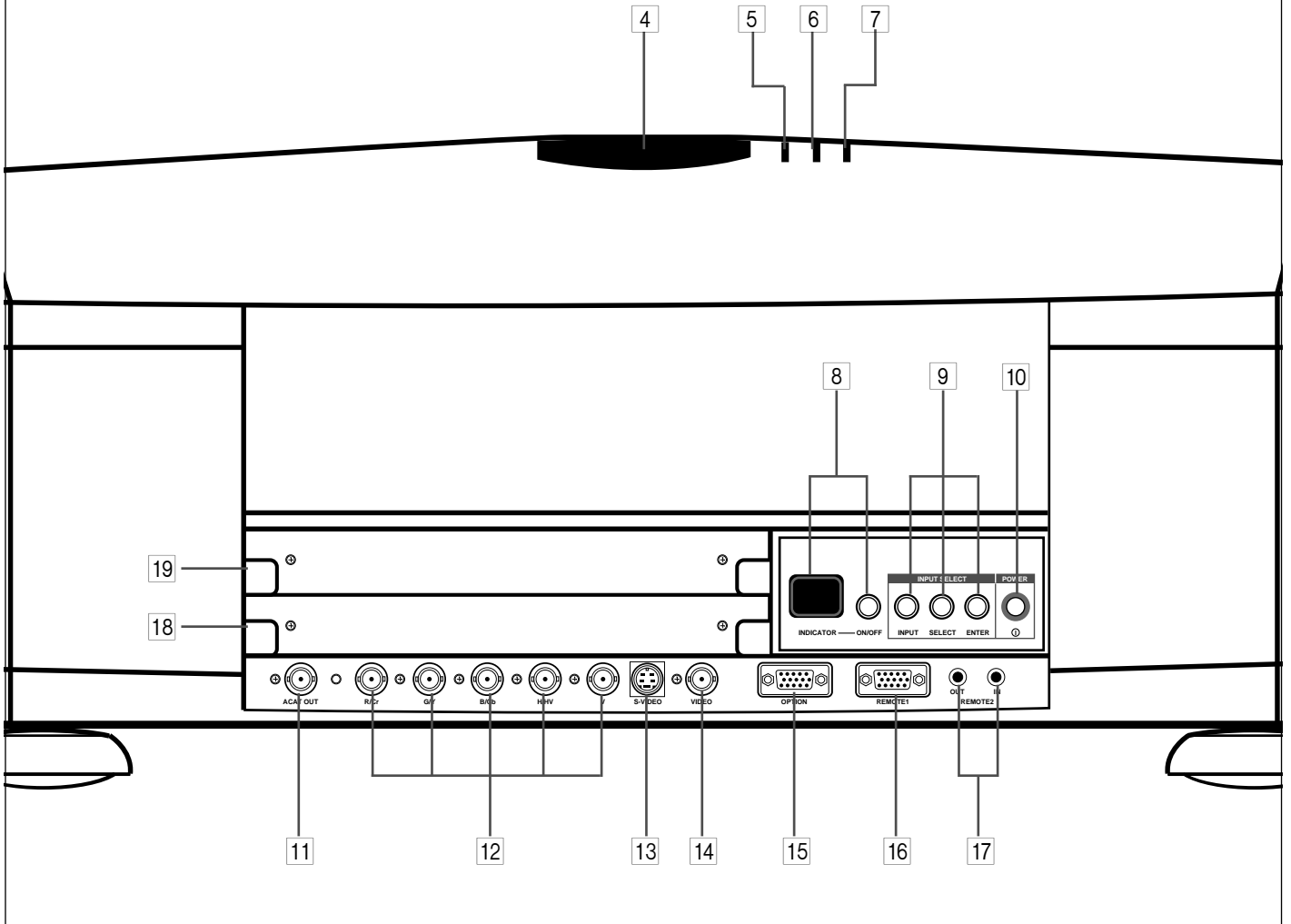

Front Panel

1 Power Switch (Main power)

To turn on the main power to the projector press the switch to the ON position (I). The STANDBY and the RC READY indicator will light.

In this condition you can start up the projector by pressing the POWER ON button on the remote control or the POWER button on the rear panel.

Press to the OFF position (O) to turn the main power off.

NOTE: When turning off the main power, first return the projector to the standby condition by pressing the POWER OFF button on the remote control or the POWER button on the rear panel and then turn off the main POWER switch. These procedures are necessary to protect your projector and the connected equipment.

2 AC INPUT

Connect the supplied power cord here.

3 Remote Sensor

Receives the signal from the supplied remote control when used in the wireless mode.

Rear Panel

4 Remote Sensor

Receives the signal from the supplied remote control when used in the wireless mode.

5 POWER Indicator

Lights up when the projector is turned on.

6 STANDBY Indicator

Lights up when the projector's main POWER switch is on. Flashes when the projector is not connected with the Switcher correctly or when the Switcher is turned off.

7 RC READY Indicator

Lights up when the projector's main POWER switch is on. Flashes when the projector receives a signal from the remote control.

8 Two Digit Display INDICATOR:

Displays projector error codes. ("00" in normal operation)

ON/OFF Switch:

Turns the INDICATOR on or off.

9 INPUT SELECT Buttons

INPUT: press to display the INPUT SELECT screen.

SELECT: press to select an input by highlighting the input terminal.

ENTER: press to execute selection and to switch input.

10 POWER Button

Turns the projector on or off when the projector is in the standby condition (Main Power switch must be on and the STANDBY and the RC READY indicator lit).

11 ACAT OUT Terminal

This is a video output connector for the optional built in CCD camera. The CCD camera is needed in order to perform automatic convergence with the optional ACAT software.

12 R/Cr, G/Y, B/Cb, H H/V and V Input Terminals (INPUT A)

Connect R,G,B,H (Horizontal sync) and V (Vertical sync) outputs of the external equipment (such as the Switcher). If using a component with a combined sync (SYNC) output, connect it to the H/V terminal. When using luminance and color-difference signals of HDTV and DVD, connect a Pr/Cr to the R, a Y to the G and a Pb/Cb to the B input of the projector.

13 S-VIDEO Input Terminal (INPUT A)

Connect to the S-video output of the external equipment such as a VCR with an S-video output. This terminal allows switching between S2 and S1 VIDEO input modes.

14 VIDEO Input Terminal (INPUT A)

Connect to the video output of the external equipment such as a VCR or laser disk player.

15 OPTION Terminal

For system expansion such as PC-control.

16 REMOTE 1 Terminal

This terminal allows external control of the projector from either the Switcher or from an external control. When the Switcher is used, connect to the REMOTE 1 terminal on the back of the Switcher.

NOTE: The ISS-6020/ISS-6020G Switcher is compatible with this projector.

17 REMOTE 2 Terminal

IN: for the supplied service remote control.

OUT: connect to a second projector's IN terminal to relay the input at the IN terminal.

NOTE: The wireless control does not work when the plug of the supplied remote cable is inserted into the REMOTE 2 IN terminal.

18 INPUT B

Slot for adding optional RGB or video input cards.

19 INPUT C

Slot for adding optional RGB or video input cards.

NOTE: The optional RGB INPUT and VIDEO INPUT modules can be installed in the INPUT B and INPUT C slots.

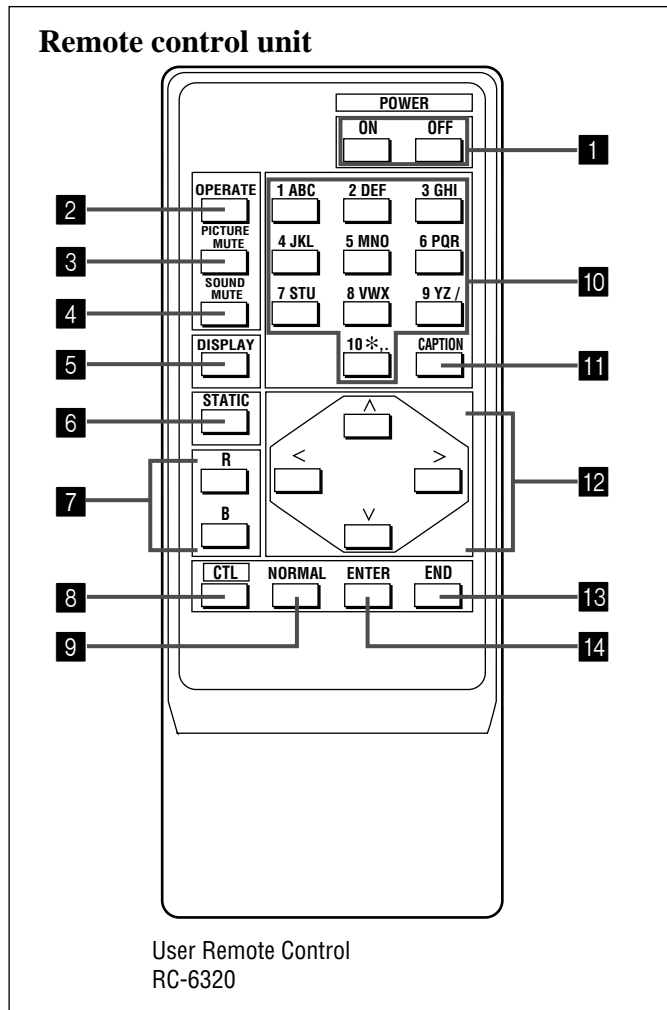

NOTE: The full function remote control is designed for setup adjustment. Use the user remote control for normal operation.

1 POWER Buttons (ON/OFF)

Press the ON button to turn the projector on when the projector is in the standby condition (STANDBY and RC READY indicators lit). Press the OFF button to return the projector to the standby condition.

2 OPERATE Button

Press to display the "OPERATE" menu.

3 PICTURE MUTE Button

Press to mute the picture. Press again to display the picture. You can also mute the picture by holding down CTL and pressing PICTURE MUTE buttons. To restore the picture, holding down CTL and press PICTURE MUTE again. Or simply press END.

NOTE: When the picture is muted by using CTL and PICTURE MUTE buttons, even if an input is switched to another or the power is turned off using the remote POWER OFF button, the mute cannot be canceled.

4 SOUND MUTE Button

Press to mute the sound. Press again to return the sound.
NOTE: This works only with the ISS-6020/ISS-6020G Switcher.

5 DISPLAY Button

Press to turn on or off the on-screen display. Pressing with CTL eliminates the on-screen display; pressing with CTL again restores it.

NOTE: Even if the on-screen display may be turned off with pressing CTL and DISPLAY, any adjustment will still change the projector's memory settings. This mode is available even when an input is switched to another or the power is turned off using the POWER OFF button on the remote control.

6 STATIC Button

Press to enter the STATIC mode. You can adjust the static convergence.

7 R and B Buttons

Turn each CRT beam on and off separately. When using with the CTL button, you can select the CRT to be adjusted during static convergence.

8 CTL Button

Used in conjunction with other buttons, similar to a shift key on a computer.

9 NORMAL Button

Returns the standard level for each signal. When pressed once, the confirmation message will be displayed. When "YES" is selected and ENTER is pressed, the data will be returned to the standard level. While holding down the CTL button, press the NORMAL button to display the "LOAD/CANCEL" menu to select either LOAD (last stored level) or CANCEL (data cancelled).

10 INPUT Buttons

Select menus and switches input signals.

11 CAPTION Button

Press to display the CLOSED CAPTION menu.

12 CURSOR Buttons

Used for increasing and decreasing control levels, cursor movement and convergence adjustments.

13 END Button

Ends the adjustment mode.

14 ENTER Button

Executes menu selection and switches to selected input.

Battery installation and replacement

User remote control (RC-6320)

1 Press down on the battery compartment cover and slide the cover in the direction of the arrow.

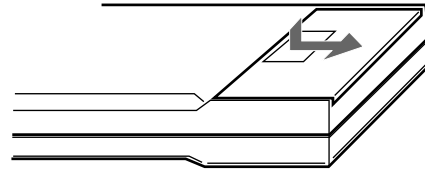

2 Install the two new batteries, making sure that their polarity matches the \oplus \ominus diagrams inside the battery compartment. Incorrect polarity could damage the unit.

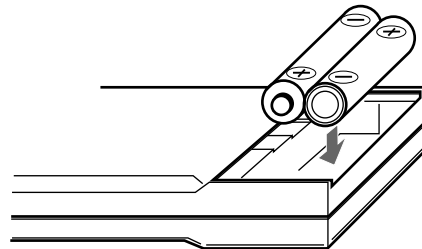

3 Close the battery compartment cover.

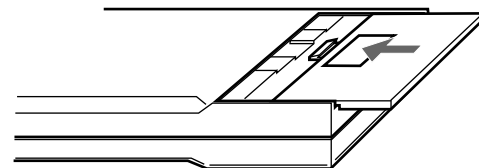

NOTE: The remote control is powered by two alkaline 1.5V AA batteries.

Remote control cautions

Use the remote control within a distance of about 7m (23 ft.) and at 30 degrees angle left and right.

Handling remote control and batteries

- Do not drop or mishandle the remote.
- Do not get the remote wet. If the remote gets wet, wipe it dry immediately.
- Avoid heat and humidity.
- When not using the remote for a long period, remove the batteries.
- Do not use new and old batteries together, or use different types together.
- Do not take apart the batteries, heat them, or throw them into a fire.

EXAMPLES OF CONNECTIONS

CAUTIONS ON CONNECTIONS:

- Unplug the projector and other equipment from the AC supply before making connections.
- Make sure that the plug of the power cord is properly connected to the power outlet. A loose connection may cause hum or noise.
- Confirm your connection layout with the user's manual accompanying the equipment to be connected with the ISS-6020/ISS-6020G Switcher.

When Used in Stand Alone Operation

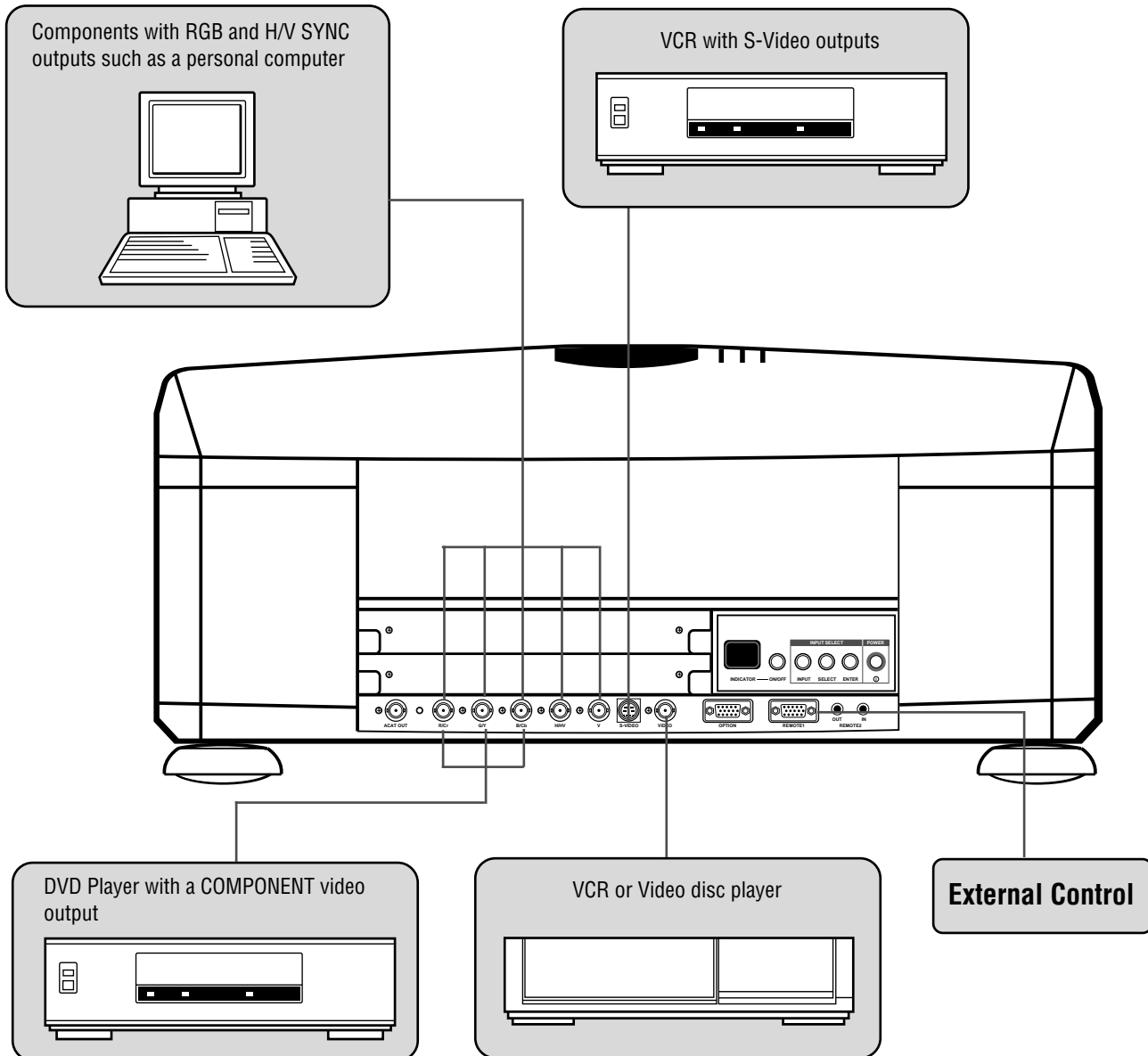

NOTE: This projector does not have built-in speakers.

- Make sure that the STANDALONE mode is selected from the CONNECT CONDITION menu. Contact your dealer for the information in detail.

When Used with One Switcher (ISS-6020/ISS-6020G)

Up to 10 input signals can be accepted when the projector is connected to one Switcher. Using the projector with the Switcher allows easy adjustment and signal selection.

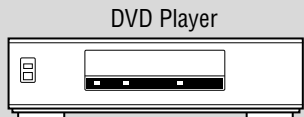
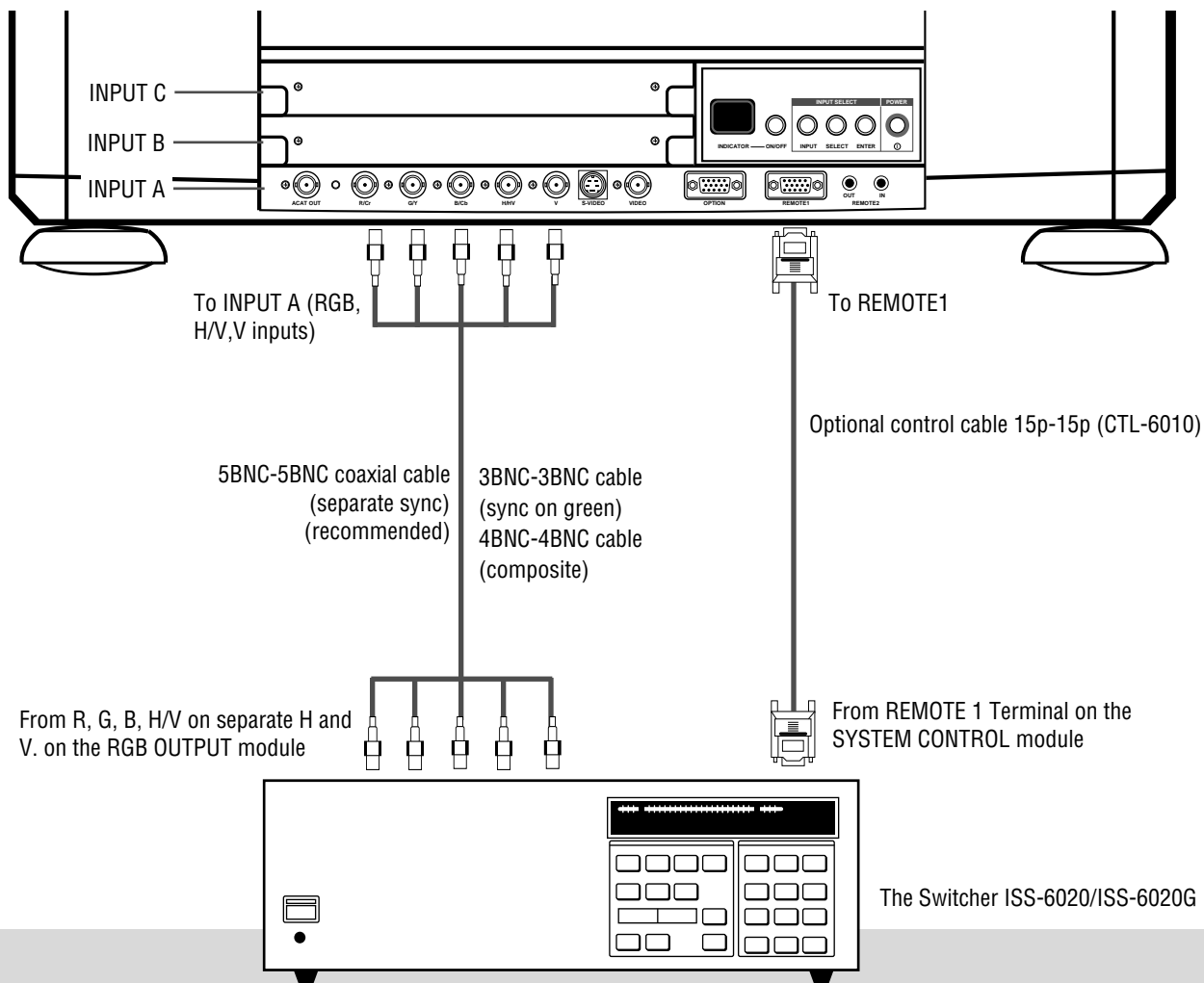

DVD Player

* To connect a COMPONENT signal of the equipment such as DVD player to the optional RGB input board, the projector must recognize the optional RGB input board as a COMPONENT input board. See "RGB/COMPONENT Search Setting" of the Set-up manual.

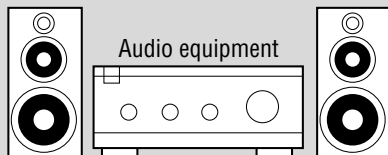

Audio equipment



VCR



Personal computer

- Make sure that the SW1 LEVEL mode is selected from the CONNECT CONDITION menu. Contact your dealer for the information in detail.
- For more information on the Switcher, refer to the user's manual accompanying the ISS-6020/ISS-6020G Switcher.
- All cables mentioned above are optional.

EXAMPLES OF CONNECTIONS

When Used with Two or More Switchers (100 Inputs)

Up to 100 inputs can be accepted using the Switcher.

How to make connections:

- ① Connect the REMOTE 1 terminal of the master Switcher to the REMOTE 1 of the projector using the optional control cable (15p-15p/CTL-6010).
- ② Next connect the REMOTE 2 terminal of the master Switcher to the REMOTE 1 terminal of the first slave Switcher using the same optional control cable as mentioned above. Third, connect the REMOTE 2 terminal of the first slave to the REMOTE 1 of the second slave, and the REMOTE 2 terminal of the second slave to the REMOTE 1 terminal of the third slave (— and the REMOTE 2 of the ninth slave to the REMOTE 1 of the tenth slave). Connect all the Switchers with optional control cables.

NOTE:



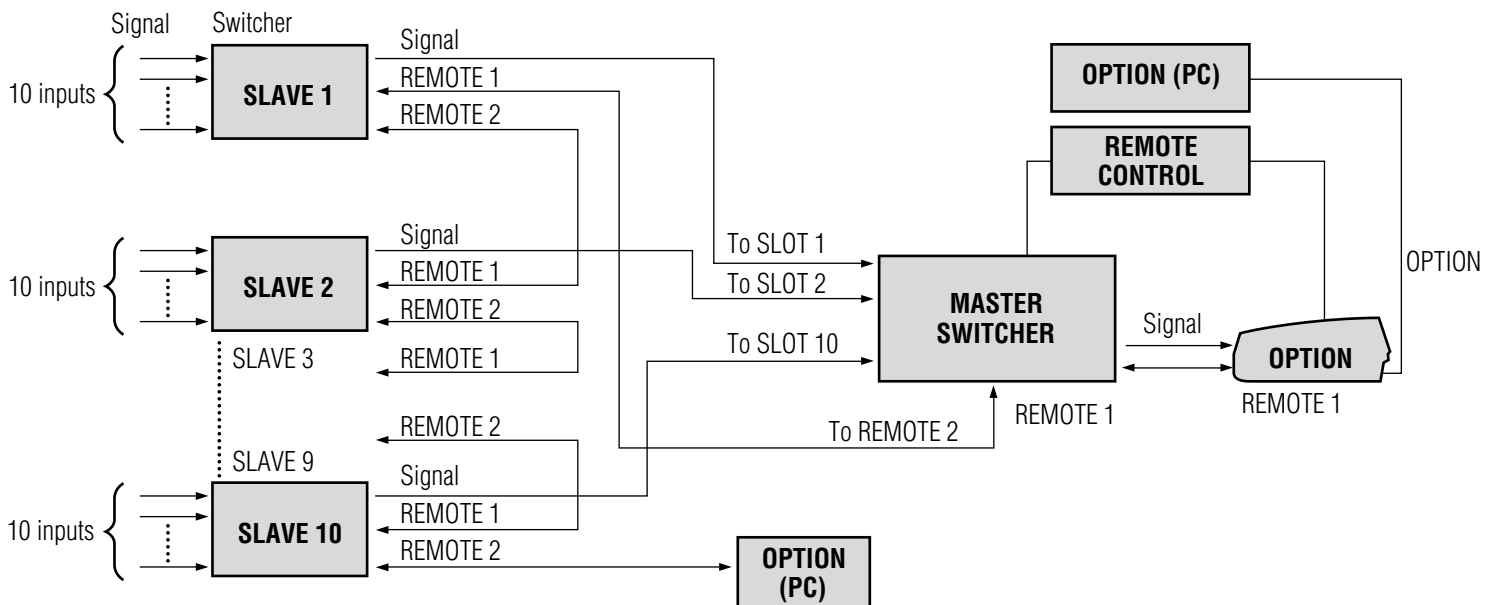



- Be sure to set all the slide switches (S8603) of the Switcher to RS-422 positions. Set the one on the last slave Switcher to the appropriate position to match the connected equipment such as a personal computer. (RS-422/RS-232C for PC control of projector)
- Set the DIP switch S8601 of the Switcher.

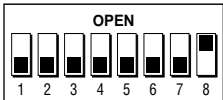
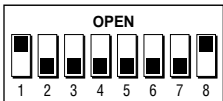

- Make sure that the SW2 LEVEL mode is selected from the CONNECT CONDITION menu. Contact your dealer for the information in detail.
- Refer to the user's manual accompanying the Switcher.
- Cables mentioned are not included with the projector.

Set the DIP switch (S8601) of the Switcher as follows:

NOTE: Slave numbers 1 to 10 must correspond to the master's slot numbers 1 to 10.

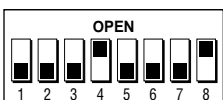
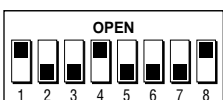
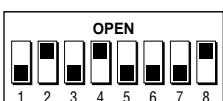
ISS-6020 ISS-6020G	Output to	Setting of S8601
Master	The Projector	
Slave 1	Slot 1 of the Master	
Slave 2	Slot 2 of the Master	
Slave 3	Slot 3 of the Master	
Slave 4	Slot 4 of the Master	
Slave 5	Slot 5 of the Master	
Slave 6	Slot 6 of the Master	
Slave 7	Slot 7 of the Master	
Slave 8	Slot 8 of the Master	
Slave 9	Slot 9 of the Master	
Slave 10	Slot 10 of the Master	

EXAMPLES OF CONNECTIONS

REMOTE 1 Terminal

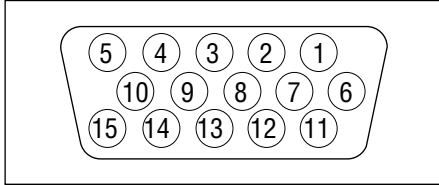

This terminal is used for either connecting the ISS-6020/ISS-6020G Switcher or a third party external control device. When the Switcher is used, connect it with the optional control cable (15-15 pin; 50 ft./16m; CTL-6010) to this terminal.

When used with the Switcher.

Pin No.	FUNCTION
1, 2, 6 and 7	Sending and receiving data when the Switcher is used.
9	Identifying the Projector
15	Ground
Others	Used inside the Projector. Normally set to OPEN.

When using with the Switcher ISS-6020/ISS-6020G, connect no. 1,2,6,7,9 and 15 pins of the projector to the same no. pins of the switcher as shown below.

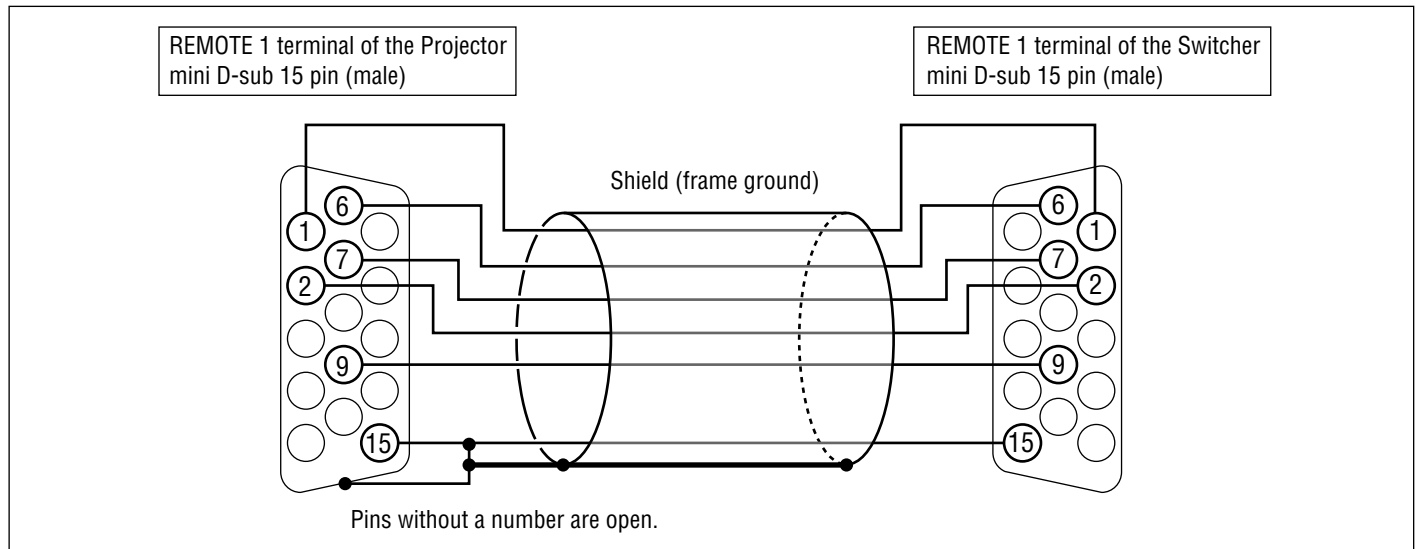

Pin Configuration of Optional CTL-6010 Cable

When used in stand alone operation.

Pin No.	SHORT/OPEN			FUNCTION		Remote button
14	SHORT OPEN			External control mode ON External control mode OFF		-
5	SHORT			POWER ON		POWER ON
	OPEN			POWER OFF		POWER ON
10	SHORT			PICTURE MUTE ON		PICTURE MUTE
	OPEN			PICTURE MUTE OFF		
4,8, and 12	12	8	4			
	OPEN	OPEN	OPEN	INPUT A	RGB*1	1
	OPEN	OPEN	SHORT	INPUT A	VIDEO	2
	OPEN	SHORT	OPEN	INPUT A	S-VIDEO	3
	OPEN	SHORT	SHORT	INPUT A	COMPONENT	10
	SHORT	OPEN	OPEN	INPUT B	*2	4
	SHORT	OPEN	SHORT	INPUT B	*3	5
	SHORT	SHORT	OPEN	INPUT C	*2	7
	SHORT	SHORT	SHORT	INPUT C	*3	8

*1 Some settings allow you to retrieve a COMPONENT signal automatically. See “RGB/COMPONENT Search Setting” of the Set-up manual.

*2 When the optional RGB input board is installed and the RGB input is set, an RGB signal will be selected; when the RGB input board is installed and the COMPONENT input is set, a COMPONENT signal will be selected; when the optional RGB input board is installed and the VIDEO input is set, a VIDEO signal will be selected.

When the optional VIDEO input board is installed, a VIDEO signal will be selected.

*3 An S-VIDEO signal will be selected when :

1. the optional RGB input board is installed and the VIDEO input is set.
2. the optional VIDEO input board is installed.

The term “SHORT” means to connect with pin 15

• When in the external control mode, the POWER, INPUT and PICTURE MUTE buttons on the remote control will not function.

NOTE: Pin 13 is the external remote signal terminal. The projector can be controlled by the same format signal as the supplied remote control from the external controller regardless of setting Pin 14.

NOTE: When turning the power on using the external control, short Pin 5 about three seconds after supplying the AC power to the projector; when turning the power off using the external control, power off the AC supply to the projector about three seconds after opening Pin 5. These procedures are to protect your projector and the connected equipment.

BASIC OPERATION

Picture Projection

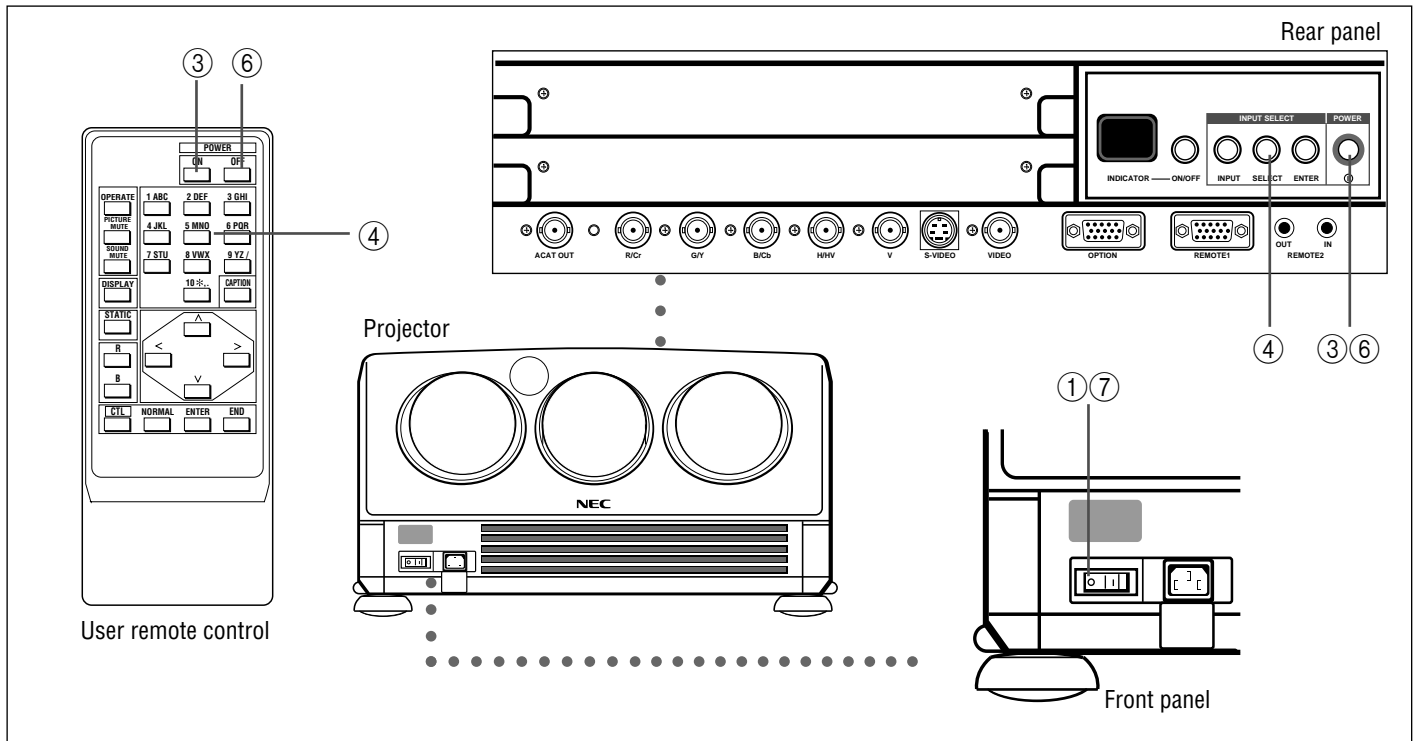

To project a picture source, proceed as follows:

- ① Turn on the main power of the projector.
 - Press the POWER switch on the front panel to the ON position (I).
- ② Turn on the power of the connected equipment.
- ③ Turn on the power of the projector.
 - Press the POWER ON button on the remote control or the POWER button on the rear panel.
- ④ Select an input signal source by pressing one of the ten INPUT buttons on the remote control. You can also select a signal from the “INPUT SELECT” list.
 - See “INPUT SELECTION” on page 24 for more details.
- ⑤ Adjust the picture and sound.
 - See pages 20 through 23 for more details.

NOTE: The volume function works only with the ISS-6020/ISS-6020G Switcher.

- ⑥ To turn off the power, press the POWER OFF button on the remote control or the POWER button on the rear panel.
- ⑦ Press the POWER switch on the front panel to the OFF position (O) to turn off the main power of the projector.
- ⑧ Last, turn off the connected equipment power.

Displaying the Menu and Adjustment Screens

You can easily access your desired screen by selecting menus.

Depending upon button selection, your desired screen will be displayed as shown below:

OPERATE menu

NOTE: Some function items will not be used depending on the input signal or peripheral equipment connected.

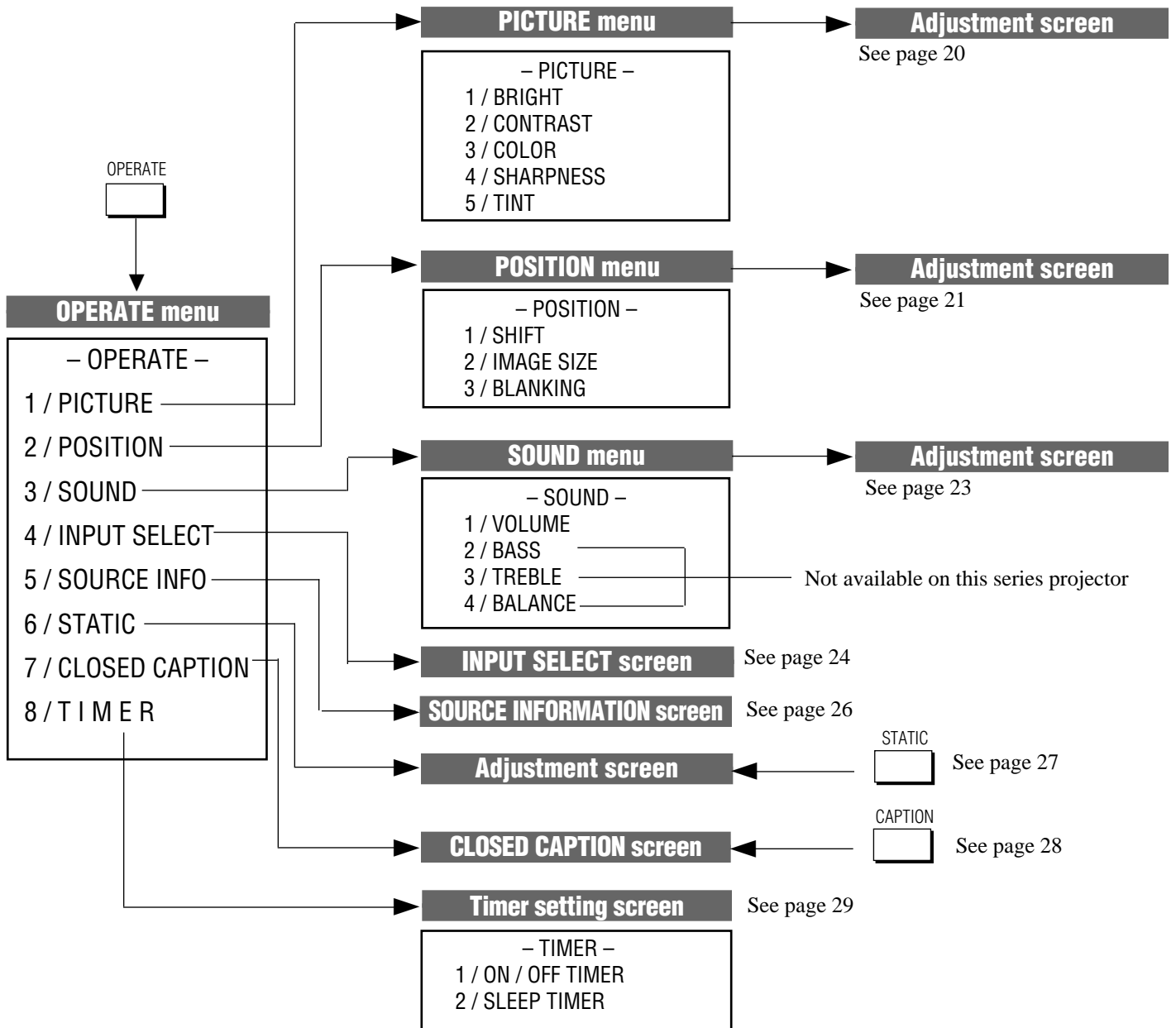

CAUTION: Do not display a bright and still picture for longer than 20 minutes. This could damage the CRTs.

NOTE: The explanation of the operation on the following pages is for use with the remote control.

Storing Projector Settings (Automatic Save Feature)

You have two options to store projector settings in the memory: automatically and manually.

- Storing time is four seconds.
- The Automatic Save Feature mode has been set to DISABLE by factory. For information on setting, see "Automatic Save Feature" in the Set-Up manual included only with the XG-1352/XG-852 models, and if you own XG-1352G/XG-852G, contact your dealer.

■ When the Automatic Save Feature mode is set to "ENABLE", projector settings will be stored in the projector's memory automatically.



Settings are stored automatically when any one of the following procedures is performed:

- The END button is pressed several times to return the adjustment screen to the source screen.
- One input is switched to another.
- The projector is turned off.
- After every 10 minutes of elapsed time.

■ When the Automatic Save Feature mode is set to "DISABLE", projector settings can be stored in the projector's memory manually.

When you try to return the source screen by pressing END several times, the "STORE ?" menu is displayed.

To manually save settings, proceed as follows:

1. Use the END button to display the "STORE" menu from the current adjustment screen or menu.
2. Use the CURSOR  or  button to highlight "CURRENT", "NEW", or "CANCEL" and press ENTER.

Items to select

- CURRENT ----- Overwrites the currently projected signal and saves the settings. NOTE: An unregistered signal cannot be stored under the "CURRENT" settings.
- NEW ----- Starting at memory location No.51, this function saves an unregistered signal as a new signal in memory.
- CANCEL ----- Does not save settings.



■ When selecting “NEW”

The current settings are registered as a new signal and are saved to an unassigned line starting at memory location No.51.

A registered name is automatically given.

The “NEW ENTRY?” menu will be displayed.

Use the CURSOR or button to highlight “YES” or “NO” and press ENTER.

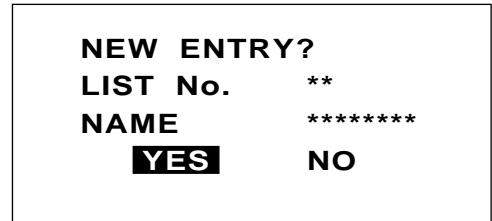

Items to select

- YES ----- Registers settings as a new signal and saves the signal in an unassigned location starting at memory location No.51.
- NO ----- Does not register settings.

A registered name is given as follows:

VIDEO/S-VIDEO ----- Video standard with a list number e.g. NTSC51 or PAL52.
 RGB ----- ”RGB” with a list number e.g. RGB60.

NOTE:





- If the Input list does not have any unassigned memory location starting at No. 51 then, the “NEW” item will be selectable. For signal registration see “SIGNAL ENTRY” in the Set-Up manual included only with the XG-1352/XG-852 models, and if you own XG-1352G/XG-852G, contact your dealer.
- The Automatic Save Feature is available only for signals listed in the INPUT LIST.

BASIC OPERATION

Picture Adjustment

To adjust the picture for each input, proceed as follows:





NOTE: The color, sharpness, and tint controls are not selected in the "PICTURE" menu for RGB signal. The tint control is not selected in the "PICTURE" menu for SECAM/PAL signal.

- ① Press the OPERATE button.
 - The "OPERATE" menu is displayed.
- ② Use the CURSOR  or  button to highlight the "1/PICTURE" line and press ENTER to display the "PICTURE" menu. You can also select the "PICTURE" menu directly by pressing the INPUT "1" button.
- ③ Use the CURSOR  or  button to select a picture function and then press ENTER. You can also select an item directly by pressing the corresponding number button.
 - The picture adjustment screen will be displayed.

Items to select:

- BRIGHT (Brightness control)
- CONTRAST (Contrast control)
- COLOR (Color intensity control)
- SHARPNESS (Picture detail control)
- TINT (Red and green values control)

NOTE: When you are in the BRIGHT adjustment mode, all the CRTs will be in use. The CRT beam cannot be cut-off.

- ④ Use the CURSOR buttons to adjust a picture to your preference.
 - The CURSOR  or  button increases the level.
 - The CURSOR  or  button decreases the level.
- ⑤ To end this adjustment, press the END button.
 - Wherever the END button is pressed, the screen changes in this order:
"PICTURE" menu → "OPERATE" menu → Source screen

```
- OPERATE -  
1 / PICTURE  
2 / POSITION  
3 / SOUND  
4 / INPUT SELECT  
5 / SOURCE INFO  
6 / STATIC  
7 / CLOSED CAPTION  
8 / T I M E R
```

```
- PICTURE -  
1 / BRIGHT  
2 / CONTRAST  
3 / COLOR  
4 / SHARPNESS  
5 / TINT
```

PICTURE





- BRIGHT -

.....▼..... 60%

Position Adjustment

Adjust the position(SHIFT), the size (IMAGE SIZE) and the screen area (BLANKING).

Proceed as follows:

- ① Press the OPERATE button.
 - The “OPERATE” menu is displayed.
- ② Use the CURSOR  or  button to highlight the “2/POSITION” line and press ENTER to display the “POSITION” menu. You can also select the “POSITION” menu directly by pressing the INPUT “2” button.
- ③ Use the CURSOR  or  button to select either “SHIFT”, “IMAGE SIZE”, or “BLANKING” and then press ENTER. You can also select each item directly by pressing the INPUT “1” , “2” or “3” button.
 - The selected adjustment screen will be displayed.

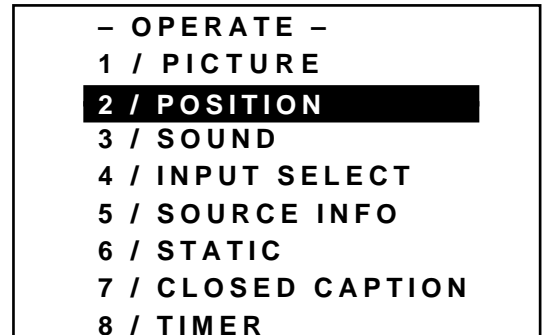





Items to select

- SHIFT (Position of the picture)
- IMAGE SIZE (Picture size)
- BLANKING(Screen area)

- ④ Adjust the position, size, or screen area.

When selecting SHIFT:

Use the CURSOR buttons to move the position of the picture.

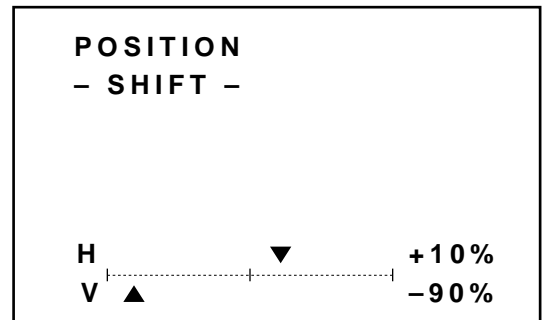

- Pressing  or  moves the picture left or right.
- Pressing  or  moves the picture up or down.





You can also finely adjust the shift .

To do so:

While displaying the SHIFT screen, press and hold CTL and press any one of the CURSOR buttons to display the SHIFT FINE screen.

Pressing  or  moves the picture left or right finely.

Pressing  or  moves the picture up or down finely.



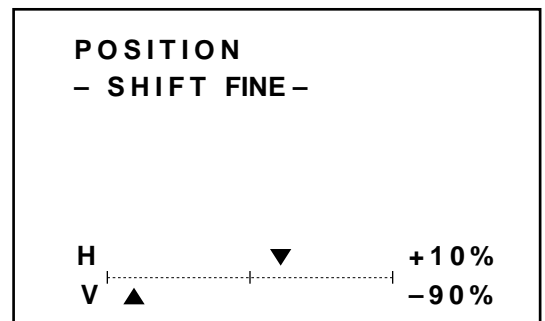

To return to the SHIFT screen, press and hold CTL, then press any one of the CURSOR buttons.



BASIC OPERATION

When selecting IMAGE SIZE:

Use the CURSOR buttons to adjust the size of image.

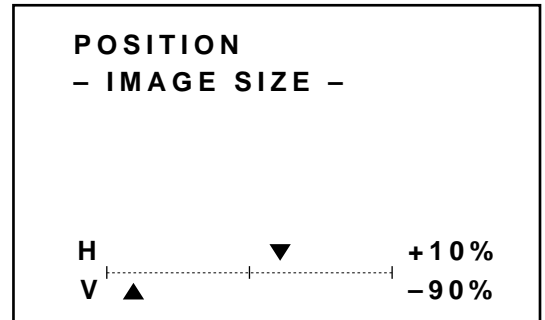

- Pressing  or  button increases or decreases the horizontal size.
- Pressing  or  button increases or decreases the vertical size.







When selecting BLANKING:



- 1) Hold down the CTL button and press CURSOR buttons to choose the right, left, top, or bottom edge.
 - The marker on the selected side will turn to a solid color.

- 2) Adjust the blanking using the CURSOR buttons.

Top and Right Pressing  or  increases the adjustment values.

Pressing  or  decreases the adjustment values.

Bottom and Left Pressing  or  increases the adjustment values.

Pressing  or  decreases the adjustment values.

- ⑤ To end this adjustment, press the END button.
 - Whenever the END button is pressed, the screen changes in this order:
"POSITION" menu → "OPERATE" menu → Source screen

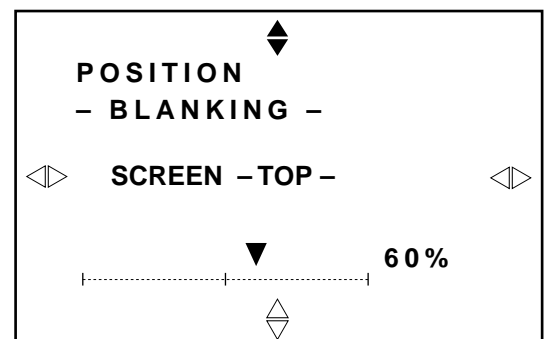





Sound Adjustment (only when used with the ISS-6020/ISS-6020G Switcher)

Adjust the volume to your preference.

Proceed as follows:

- ① Press the OPERATE button.
 - The “OPERATE” menu is displayed.

- ② Use the CURSOR  or  button to highlight the “3/SOUND” line and press ENTER to display the “SOUND” menu. You can also select the “SOUND” menu directly by pressing the INPUT “3” button.



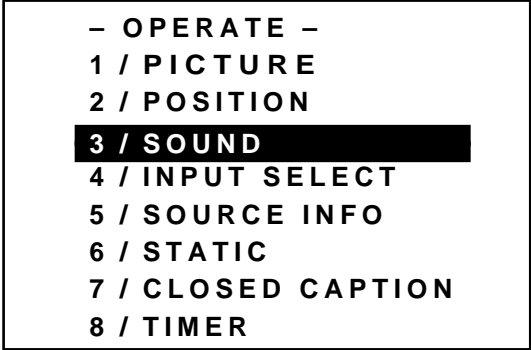

- ③ Use the CURSOR  or  button to select a sound function and press ENTER. You can also select an item directly by pressing the corresponding number button.
 - The sound adjustment screen will be displayed.

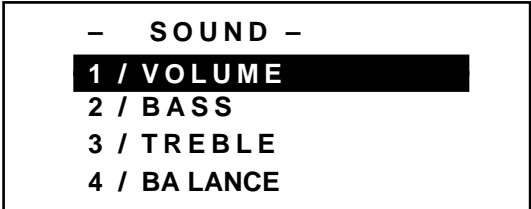

Items to select

- VOLUME
- BASS (Not available on XG135LC, XG110LC and XG75A)
- TREBLE (Not available on XG135LC, XG110LC and XG75A)
- BALANCE (Not available on XG135LC, XG110LC and XG75A)



- ④ Use the CURSOR button to adjust sound controls.
 - The CURSOR  or  button increases the level.
 - The CURSOR  or  button decreases the level.

- ⑤ To end this adjustment, press the END button.
 - Whenever the END button is pressed, the screen changes in this order:
“SOUND” menu → “OPERATE” menu → Source screen.

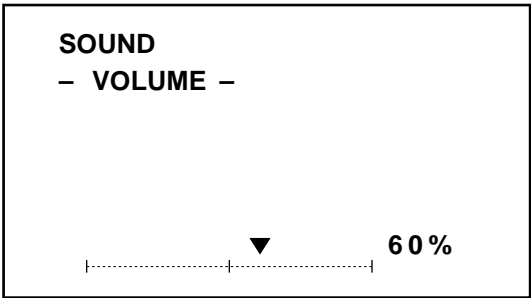



NOTE: Volume level is indicated in a red gauge during muting.



BASIC OPERATION

Input Selection



You can switch from one input to any other input signal.

Proceed as follows:

- ① Press the OPERATE button.
 - The “OPERATE” menu is displayed.
- ② Use the CURSOR  or  button to highlight the “4/INPUT SELECT” line and press ENTER to display the “INPUT SELECT” list. You can also select the “INPUT SELECT” list directly by pressing the INPUT “4” button.

- ③ Use the CURSOR  or  button to highlight the signal to be switched to and press ENTER to switch to the selected input signal.

Press the  or  button to change the sheet.

NOTE: To advance to the next page or to the previous page, hold down the CTL button then press the CURSOR  or  button. To directly access the page, hold down the CTL button then any one of the INPUT buttons.

- ④ To end the INPUT SELECT list, press the END button.
 - Whenever the END button is pressed, the screen changes in this order:
“OPERATE” menu → Source screen

To select inputs using the INPUT SELECT buttons on the rear control panel:

- 1) Press the INPUT button.
 - The INPUT SELECT menu is displayed.
- 2) Press the SELECT button to select an input terminal you wish to input.
- 3) Press the ENTER button to execute selection and to switch to the selected input.

NOTE: Pressing the INPUT button deletes the INPUT SELECT menu during input selection.

```
- OPERATE -  
1 / PICTURE  
2 / POSITION  
3 / SOUND  
4 / INPUT SELECT  
5 / SOURCE INFO  
6 / STATIC  
7 / CLOSED CAPTION  
8 / TIMER
```

```
P01/10-1 INPUT SELECT  
  
STANDALONE  
NO NAME SOURCE INPUT  
01 NTSC3.58 VIDEO A  
02 NTSC4.43 VIDEO A  
03 PAL VIDEO A  
04 SECAM VIDEO A  
05 VESA1024 RGB A  
06  
07  
08  
09  
10  
  
OUTPUT DATA : LIST NO.* *
```

```
INPUT SELECT  
INPUT A RGB  
INPUT A VIDEO  
INPUT A S-VIDEO  
INPUT A COMPONENT  
INPUT B RGB  
INPUT B VIDEO  
INPUT B S-VIDEO  
INPUT B COMPONENT  
INPUT C RGB  
INPUT C VIDEO  
INPUT C S-VIDEO  
INPUT C COMPONENT
```

NOTE:

- While you are viewing a source screen, you can also select the input signal directly by pressing the INPUT “1” through “10” button. In this case INPUT buttons function as follows:

When using the projector in stand alone operation:

Input Mode		RGB	VIDEO	S-VIDEO	COMPONENT	
Input Module A		1	2	3	1*/10	Standard
With RGB board	B	4	4	5	4	Optional (XGRGBIN(A))
	C	7	7	8	7	
With VIDEO board	B	–	4	5	–	Optional (XGVIDIN(B))
	C	–	7	8	–	

*When INPUT “1” button is selected, RGB and COMPONENT signals are retrieved in this order; when INPUT “10” button is selected, a COMPONENT signal is retrieved only.

Numbers designate INPUT buttons on the remote control.



When using the projector with the ISS-6020/ISS-6020G:

INPUT 1 through 10 → Selects the corresponding number slot of the ISS-6020/ISS-6020G

When using the projector with two ISS-6020/ISS-6020G or more:

To switch to another input signal, enter the master slot number, then the slave slot number by using INPUT buttons and press ENTER.

Example: If you want to select a signal from the no.3 slot of the slave Switcher which is connected to the no.2 slot of the master Switcher, first press the INPUT “2” button, then the INPUT “3” button and then press ENTER.

- You can switch to any input signal of NO 01 through 10 on the INPUT SELECT list by holding down the CTL button and pressing one of the INPUT buttons corresponding to the input number. To activate this function you must first select ENABLE in the DIRECT ENTRY ACCESS mode. For further details, contact your dealer.
- If there are two or more memory locations that contain the same signal information the projector will reference the signal nearest the beginning of the list. To select the next signal use the CURSOR  or  button and press ENTER.

INPUT SELECT List Format

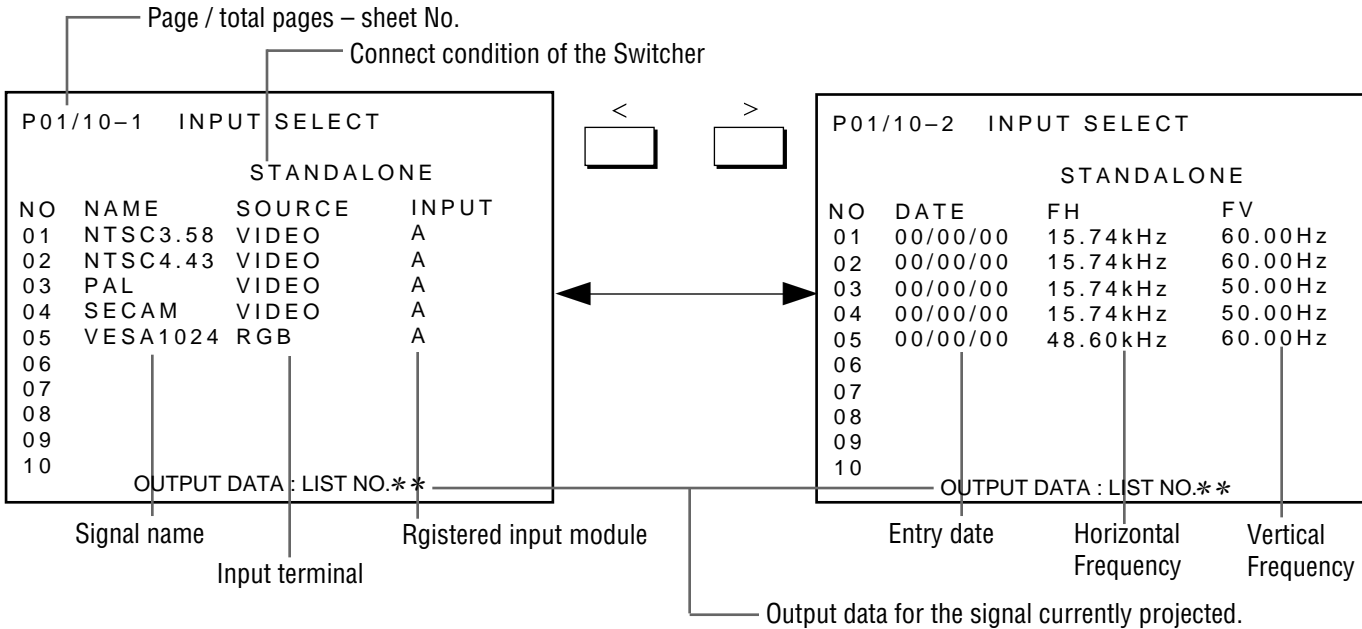





BASIC OPERATION

Source Information

This is for viewing the signal information and the current status of various settings.

Proceed as follows:

- ① Press the OPERATE button.
 - The “OPERATE” menu is displayed.
- ② Use the CURSOR  or  button to highlight the “5/SOURCE INFO” line and press ENTER to display the “SOURCE INFORMATION” screen. You can also select the “SOURCE INFORMATION” screen directly by pressing the INPUT “5” button.
- ③ Press the CURSOR  or  button to select the page.
- ④ To end the “SOURCE INFORMATION” screen, press the END button.
 - Whenever the END button is pressed, the screen changes in this order:
“OPERATE” menu → Source screen

- OPERATE -	
1 /	PICTURE
2 /	POSITION
3 /	SOUND
4 /	INPUT SELECT
5 /	SOURCE INFO
6 /	STATIC
7 /	CLOSED CAPTION
8 /	TIMER

NOTE: The items below cannot be set in the OPERATE mode.

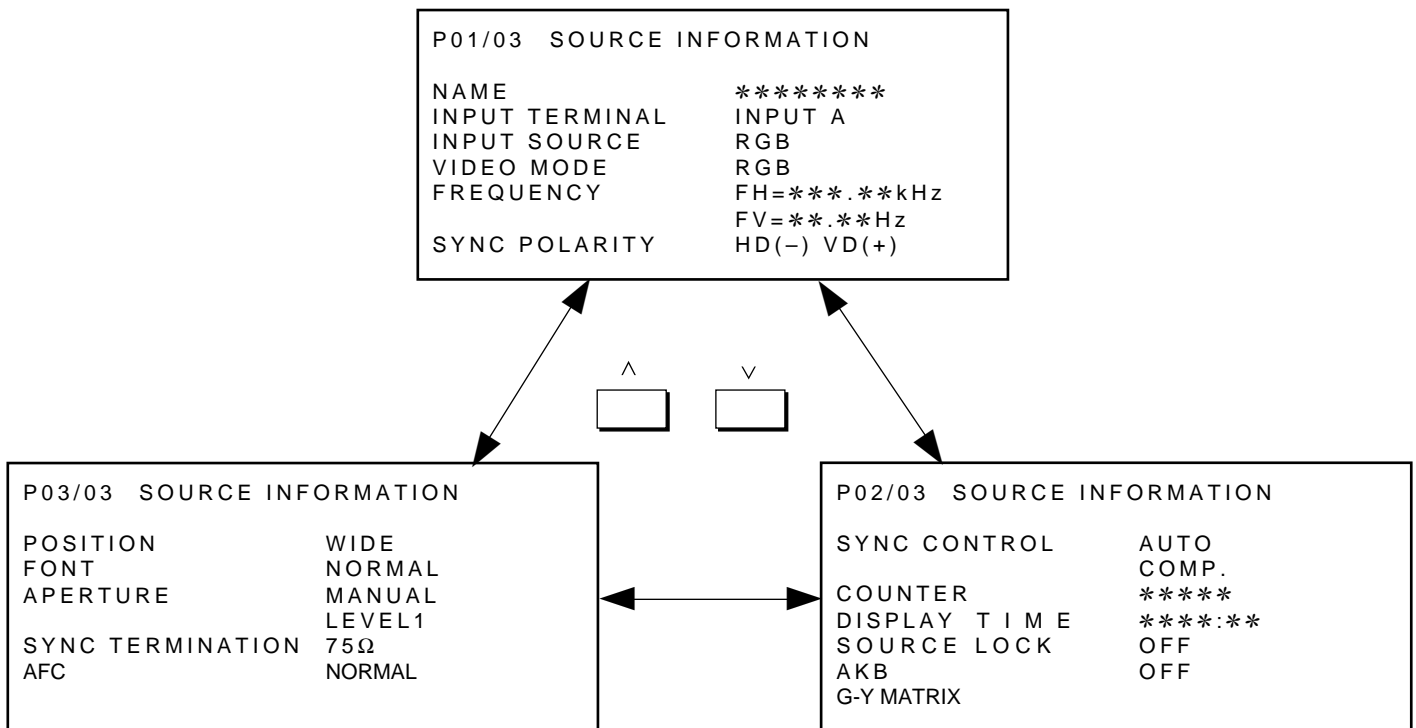







Static Convergence Adjustment

Adjust for the red and blue CRTs to place their pattern on top of the green test pattern (center only).

NOTE: The static convergence adjustment should be performed for R and B CRT. Carry out the adjustment after displaying an active image for 20 minutes or more.

Proceed as follows:

- ① Press the OPERATE button.
 - The “OPERATE” menu is displayed.
- ② Use the CURSOR  or  button to highlight the “6/STATIC” line and then press ENTER to display the STATIC adjustment screen. You can also select the STATIC adjustment screen directly by pressing the INPUT “6” button, or by pressing the STATIC button on the remote control.
 - The CROSS-HAIR test pattern will be automatically displayed.
- ③ Press the R or B button to display the pattern to be aligned with the Green pattern (as used a reference color).
 - You can turn on or off each CRT beam (R and B) separately.
- ④ Hold down the CTL button then select the CRT you wish to adjust with the R and B buttons.
- ⑤ Align the center of the Red or the Blue pattern with the center of the Green pattern using the CURSOR buttons.
 - The CURSOR  or  button moves the pattern right or left.
 - The CURSOR  or  button moves the pattern up or down.
- ⑥ Repeat steps ③ to ⑤ for the other CRTs if necessary.
- ⑦ To end this adjustment, press the END button.
 - Whenever the END button is pressed, the screen changes in this order:
 “OPERATE” menu → Source screen

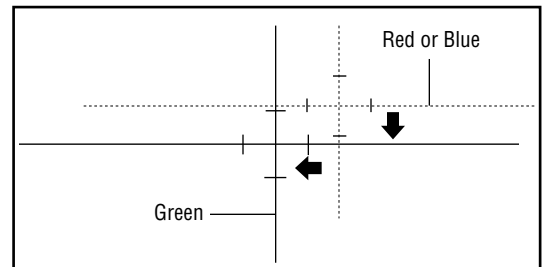
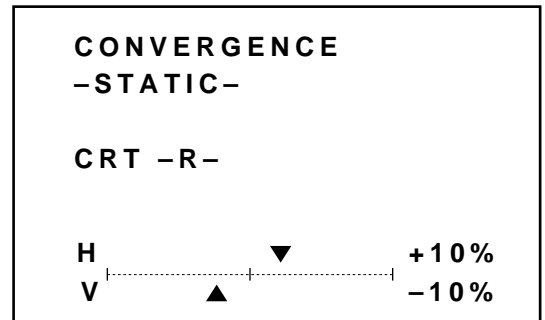
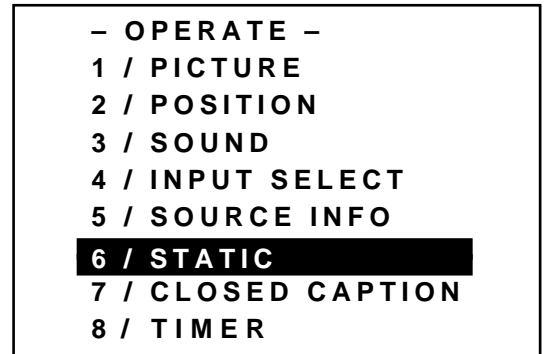





BASIC OPERATION

Closed Caption Mode Selection

Several closed caption modes can be set for text to be superimposed on the projection screen.

To select and set a mode, proceed as follows:

- ① Press the OPERATE button.
 - The “OPERATE” menu is displayed.
- ② Use the CURSOR  or  button to highlight the “7/CLOSED CAPTION” item and then press ENTER to display the “CLOSED CAPTION” menu. You can also select the “CLOSED CAPTION” menu directly by pressing the INPUT “7” button.
 - You can also select the CLOSED CAPTION menu by pressing the CAPTION button on the remote control.
- ③ Use the CURSOR  or  button to select a mode, then press ENTER.
 - The mode selection is executed.

Items to select

- CAPTION 1-4 Text is superimposed
- TEXT 1-4 Text is displayed in full screen
- OFF This exits the CLOSED CAPTION mode

NOTE:

- 1) The closed caption feature will only work with an NTSC3.58 source.
- 2) Pressing ENTER executes store function. Switching to source other than NTSC3.58 will cancel this setting. To activate, select the NTSC3.58 source again.

```
- OPERATE -  
1 / PICTURE  
2 / POSITION  
3 / SOUND  
4 / INPUT SELECT  
5 / SOURCE INFO  
6 / STATIC  
7 / CLOSED CAPTION  
8 / TIMER
```

CLOSED CAPTION

```
CAPTION1  
CAPTION2  
CAPTION3  
CAPTION4  
TEXT1  
TEXT2  
TEXT3  
TEXT4  
OFF
```

- ④ To return to the operate menu, press the END button.
 - Wherever the END button is pressed, the screen changes in this order:
“OPERATE” menu → source screen

Setting Timer





Your projector can be programmed to turn on or off automatically at a specified time. The two timer functions are available: ON/OFF TIMER and SLEEP TIMER.

NOTE:

When the ON TIMER is set and the projector is in standby, the two digit indicator flashes "00" to indicate that the ON TIMER is active.

Proceed as follows:

- Before setting ON/OFF TIMER, make sure that the DATE, TIME PRESET feature is set.
- Even after setting ON/OFF TIMER, turning the projector on or off with the remote control is possible.
- This timer setting is defeated when the projector carries out a Sequencer program. See "Auto Sequence Setting" in Set-Up manual for more information.
- There are two time display formats: 24-hour or AM/PM format. You can set either format in the "DATE TIME DISPLAY" of the OPTION menu See "Various Settings-Setting DATE, TIME DISPLAY Setting" in the Set-Up manual.

- ① Press the OPERATE button.
 - The "OPERATE" menu is displayed.
- ② Use the CURSOR  or  button to highlight the "8/TIMER" item and then press ENTER to display the "TIMER" menu. You can also select the "TIMER" menu directly by pressing the INPUT "8" button.
- ③ Use the CURSOR  or  button to select "ON/OFF TIMER" or "SLEEP TIMER".





Items to select

- ON/OFF TIMER Programs to turn on or off the power at a predetermined time.
- SLEEP TIMER Programs to turn off the power at a predetermined time, up to two hours later in 30-minute increments.

- OPERATE -
 1 / PICTURE
 2 / POSITION
 3 / SOUND
 4 / INPUT SELECT
 5 / SOURCE INFO
 6 / STATIC
 7 / CLOSED CAPTION
 8 / **TIMER**

- TIMER -
 1 / **ON / OFF TIMER**
 2 / SLEEP TIMER

■ Setting ON/OFF TIMER

- 1) Use the CURSOR  or  button to select "ON/OFF TIMER" and press ENTER to display the "ON/OFF TIMER" menu. You can also select the "ON/OFF TIMER" menu directly by pressing the INPUT "1", or by holding down CTL and pressing POWER ON on the remote control.
- 2) Use the CURSOR  or  button to highlight the program number and press ENTER to display the selected "PROGRAM" screen. You can also select the "PROGRAM" screen by INPUT "1" through "8" button.

BASIC OPERATION

- 3) Use the CURSOR or button to select "EDIT" or "CLEAR", and then press ENTER.

Items to select

- EDIT ----- Enters the mode for changing setting time.
- CLEAR ----- Deletes the current setting time.

When making a new setting or selecting "EDIT":

Select "EDIT", and press ENTER to display the "DAY" setting menu which allows you to set the day of the week for TIMER.

- a) Use the CURSOR or button to select the day of the week to be registered and press ENTER.
- The "EVERY WEEK" menu is displayed.

Items to select

- MON ----- Monday
- TUE ----- Tuesday
- WED ----- Wednesday
- THE ----- Thursday
- FRI ----- Friday
- SAT ----- Saturday
- SUN ----- Sunday
- MON-FRI ----- Monday thru Friday
- MON-SAT ----- Monday thru Saturday
- MON-SUN ----- Monday thru Sunday

- b) Use the CURSOR or button to select an item and then press ENTER.
- When "YES" is selected, the item on the day field in the ON/OFF TIMER menu is marked with the letter "E" which indicates that the setting time is enabled.

Items to select

- YES ----- Programs to turn on or off every week.
(not deleted after executing the program)
- NO ----- Does not program to turn on or off every week.
(deleted after executing the program)

- The "ON TIMER" setting screen is displayed.
- c) Enter the ON TIMER time in the HH:MM format using INPUT buttons and the CURSOR or button and then press ENTER. Pressing NORMAL cancels the ON TIMER time.

-ON/OFF TIMER-			
PRG	DAY	ON	OFF
1			
2			
3			
4			
5			
6			
7			
8			
		ACTIVE	INACTIVE

-PROGRAM-	
EDIT	CLEAR

DAY	
TUE	
WED	
THE	
FRI	
SAT	
SUN	
MON-FRI	
MON-SAT	
MON-SUN	

EVERY WEEK?	
YES	NO

- The time display format varies depending on the setting in “DATE TIME DISPLAY” of the “OPTION” menu.
- The “OFF TIMER” setting screen is displayed.

NOTE:
When the ON TIMER is set alone, the timer is programmed to turn off after four hours. While this setting is effective, if any button on the remote control or the rear panel is pressed, or if any operation is made from the external control, the timer will extend the current setting time to add four more hours.



- d) Enter the OFF TIMER time in the HH:MM format using INPUT buttons and the CURSOR or button and then press ENTER. Pressing NORMAL cancels the OFF TIMER time.
- The time display format varies depending on the setting in “DATE TIME DISPLAY” of the “OPTION” menu.
 - The “ON/OFF TIMER” setting screen is displayed.

-ON/OFF TIMER-			
PRG	DAY	ON	OFF
1	MON	09:00	12:00
2	MON-FRI	14:00	15:30
3	MON-SAT	18:00	19:00
4	TUE	22:00	06:00
5			
6			
7			
8			
		ACTIVE	INACTIVE

When selecting “CLEAR”:

- Select “CLEAR” and press ENTER to clear the setting time for the selected program number.
- The “ON/OFF TIMER” menu is displayed.

4) Use the CURSOR or button to select “ACTIVE” or “INACTIVE” and then press ENTER.

Items to select	
• ACTIVE -----	Enables ON/OFF TIMER
• INACTIVE -----	Disables ON/OFF TIMER

-ON/OFF TIMER-			
PRG	DAY	ON	OFF
1	MON	09:00	12:00
2	MON-FRI	14:00	15:30
3	E MON-SAT	18:00	19:00
4	TUE	22:00	06:00
5			
6			
7			
8			
		ACTIVE	INACTIVE

When selecting “ACTIVE”:

- Select “ACTIVE” and press ENTER to enable the programmed timer function.
- The “ON/OFF” display appears on the top left of the screen. When the all the programs are completed, this display disappears.
 - When the OFF TIMER is set, the “THE PROJECTOR WILL TURN OFF SOON” display appears three minutes before turning off.

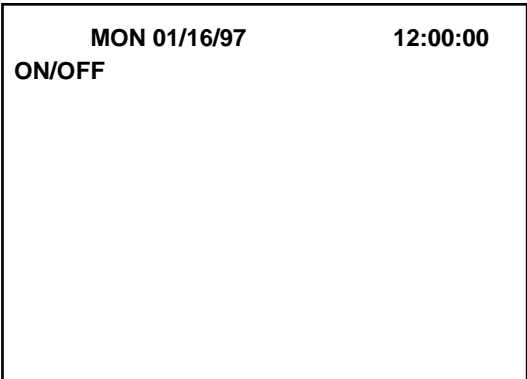



When selecting “INACTIVE”:



- Select “INACTIVE” and press ENTER to disable the programmed timer function.
- The scree is returned to the “TIMER” menu and the “ON/OFF” display disappears.

BASIC OPERATION

■ Setting SLEEP TIMER

- 1) Use the CURSOR  or  button to highlight the “2/ SLEEP TIMER” and press ENTER to display the “SLEEP TIMER” menu. You can also select the “SLEEP TIMER” menu directly by pressing the INPUT “2” or by holding down CTL and pressing POWER OFF on the remote control.

-TIMER-
1/ ON/OFF TIMER
2/ SLEEP TIMER

- 2) Use the CURSOR  or  button to select the time between 30 minutes and 2 hours in 30 minutes.

SLEEP TIMER -:--

Items to select

- -:-- ----- Does not use SLEEP TIMER
- 0:30 ----- 30 minutes
- 1:00 ----- 1 hour
- 1:30 ----- 1 and half an hour
- 2:00 ----- 2 hours



SLEEP TIMER 1:30

- 3) Select the desired time and press ENTER.
 - The “SLEEP” display appears on the top left of the screen.
 - When the SLEEP TIMER is set, the “THE PROJECTOR WILL TURN OFF SOON” display appears three minutes before turning off.

MON 01/16/95 12:00:00
SLEEP

- 4) To refer the remaining time, select the “2/SLEEP TIMER” in the “TIMER” menu and press ENTER to display the SLEEP TIMER screen. This indicates the remaining time.
 - You can also display the remaining time by holding down CTL and pressing POWER OFF on the remote control.
 - To change the setting time, repeat the step 2).

SLEEP TIMER -:48

- 5) To cancel the setting sleep time, select the “2/SLEEP TIMER” in the “TIMER” menu and press ENTER to display the SLEEP TIMER screen. This indicates the remaining time. Use the CURSOR  or  button to clear the settings. The display changes to “-:--”. Then press ENTER.
 - The “SLEEP” display disappears on the top left of the screen.
 - You can also cancel the time by holding down CTL and pressing POWER OFF on the remote control.

- ④ To return to the source screen, press the END button while the TIMER menu is displayed.
 - Wherever the END button is pressed, the screen changes in this order:
“TIMER” menu → “OPERATE” menu → source screen

Mute

This function mutes the picture, sound or on-screen display.

To mute picture:

- Press the PICTURE MUTE button. To restore the picture, press the PICTURE MUTE button again or the END button.
- You can also mute the picture by holding down CTL and pressing PICTURE MUTE.

To mute sound:

- Press the SOUND MUTE button. To restore the sound, press the SOUND MUTE button again or the END button. Note that this function works only with the ISS-6020/ISS-6020G.

To mute on-screen display:

- Press the DISPLAY button. To restore the on-screen display, press the DISPLAY button again or the END button. Pressing CTL + DISPLAY button together will eliminate the on-screen display: pressing this combination again will restore the display.

NOTE: The OPERATE menu can be accessed in the PICTURE MUTE mode.

See “Remote Control Unit” of “Part Names and Functions” for more details.

Normal, Load, and Cancel Function

Adjustment settings can be returned to the factory preset level, or previously stored level, or can be cancelled.

To return to the standard level (NORMAL):

- ① Press the NORMAL button.
 - A confirmation message will be displayed.
- ② Use the CURSOR or button to select “YES”.
- ③ Press ENTER.
 - The NORMAL function is performed.
 - If you select “NO”, you will exit this mode suspending current status.

To return to the last stored level (LOAD):

- ① Press and hold the CTL button then press the NORMAL button.
 - The “LOAD/CANCEL” menu is displayed.
- ② Use the CURSOR or button to select “LOAD”.
 - A confirmation message is displayed.
- ③ Use the CURSOR or button to select “YES”.
 - If you select “NO”, you will exit this mode suspending current status.
- ④ Press ENTER.
 - The LOAD function is performed.

To cancel the adjustment data (CANCEL):

- ① Press and hold the CTL button then press the NORMAL button.
 - The “LOAD/CANCEL” menu is displayed.
- ② Use the CURSOR or button to select “CANCEL”.
 - A confirmation message is displayed.
- ③ Use the CURSOR or button to select “YES”.
 - If you select “NO”, you will exit this mode suspending current status.
- ④ Press ENTER.
 - The CANCEL function is performed.

XXXXXXXX
DATA NORMALIZE?

YES

NO

XXXXXXXX refers to a specific adjustment item to be normalized

XXXXXXXX

LOAD
CANCEL

XXXXXXXX refers to a specific adjustment item to be loaded or cancelled

XXXXXXXX
DATA LOAD?

YES

NO

XXXXXXXX refers to a specific adjustment item to be loaded

XXXXXXXX
DATA CANCEL?

YES

NO

XXXXXXXX refers to a specific adjustment item to be cancelled

Data Area for Output and Storage

Adjustment data have different reference data areas depending on each operation.

Adjustment Area

All Gain : All adjustment data except Ref.Adjust data
 Ref. Adjust : Ref.Adjust data

Adjustment data fall into two: REF. ADJUST menu adjustment and the other adjustment data (Operate and Adjust menu).
 Data area falls into five:

Data Area

INPUT LIST (00-99) : Registered data (100) areas corresponding to INPUT LIST
 DEFAULT DATA (1-6) : Default (6) areas divided by horizontal frequency.
 Cancel Data : Data to be returned to default
 Ref.Adjust Data : REF.ADJUST data (1) area
 Ref.Adjust (FACTORY AREA) : REF.ADJUST data (1) area for factory preset.

NOTE: See the Set-up manual for ADJUST and REF.ADJUST menus.

Output Data Area

	Ref.Adjust Data	All Gain
Signal Select	Input List (00-99) or Default Data (1-6)	Ref. Adjust Data
Normalize	Default Data (1-6)*	Ref. Adjust Data (Factory Area)
Load	Input List (00-99)*	Ref. Adjust Data
Cancel	Cancel Data*	←

* The above list may be different if NORMAL/LOAD/CANCEL operation is performed during POINT convergence.
 Output data during adjusting is the amount of data in each data area and data other than the current adjustment item (data in working area).

Example for FINE adjustment

	Point Data while adjusting Fine
Normalize	Default Data (1-6) + Point data except the current Fine data
Load	Input List (00-99) + Point data except the current Fine data
Cancel	Cancel Data + Point data except the current Fine data

Storage Area of Data

	All Gain	Ref. Adjust
STORE	INPUT LIST (00-99)*	REF. ADJUST

* Point adjustment has more than one item and each item has its own working area. However, there is only one area where data is saved with the Store function, which means no distinction is made among items in data.

Searching Registered Signals

When a source is switched with the remote control or a signal is input, the projector searches the registered signals and outputs its adjustment data as follows:

By using the horizontal frequency the projector searches up to 100 signals previously stored in the INPUT LIST and up to six signals stored in the DEFAULT AREA for a matching or close data to output.

- * When a matching data is found in the INPUT LIST, the matching data will be displayed.
- * When a data with a different input terminal is found, the input terminal and input signal name will be displayed in yellow and output its data.
- * When the data is found in the DEFAULT AREA, the data will be displayed as NEW SIGNAL.
- * When no matching data is found, the nearest thing to a NEW SIGNAL data will be displayed.

This section helps you resolve problems you may encounter while inputting a COMPONENT signal.

- * When a copy-guard-capable software source is played on a DVD player, white lines outside of a picture may appear. If this happens, perform the blanking adjustment.

Regardless of whether or not using a DVD player, when a copy-guarded signal is input, a picture may be distorted at the top of the screen. If this happens, enlarge the image size to display the portion of distortion outside of the screen.

- * When switching signals with the external equipment, there may be cases where G-Sync and DVD signals with horizontal frequencies of approximately 15 kHz cannot be discriminated. There may be cases where an unregistered G-Sync signal with a horizontal frequency of approximately 15 kHz may be mistaken for a DVD signal and may not be displayed correctly. When using G-Sync and DVD signals with horizontal frequencies of approximately 15 kHz at the same time, do not use the same input terminal.
- * A COMPONENT signal can be input with the RGB input board installed when the projector is used with the ISS-6020 switcher on the SW level mode. To enable this, you must first specify the RGB input board as the COMPONENT input board on the projector. See "Setting Mode-RGB/COMPONENT Searching of the Set-up manual.

Screen Format in Projecting a Picture

NOTE: The example of the screen display is only when used with the ISS-6020/ISS-6020G.

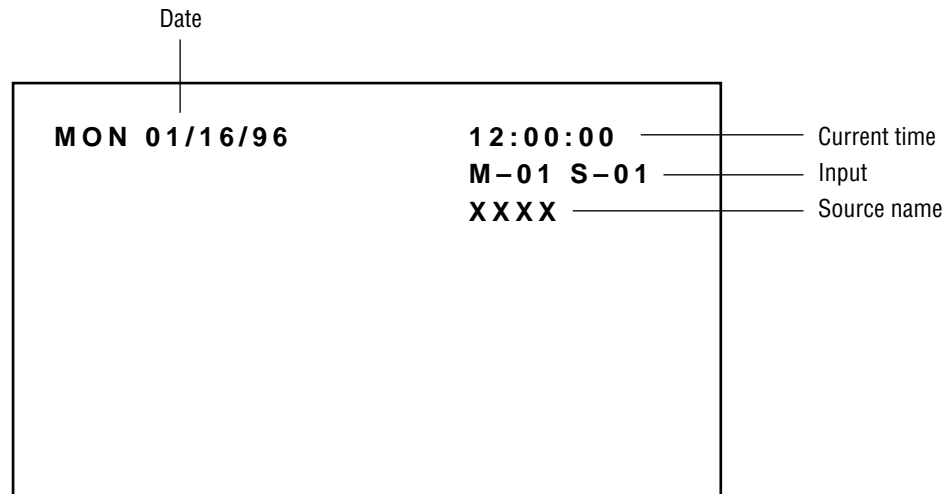

NOTE:

- See the Set-Up manual (not included with XG-1352G/XG-852G) or contact your dealer for changing the on-screen display mode.
- If the main power is not supplied to the projector for three days or more, the built-in clock may be reset. If this happens, contact your dealer for setting date and time.

SPECIFICATIONS

projection type	Refraction type Projector and screen are separated
Projection system	3 lens and 3 CRTs in-line
Scanning frequency	(XG-1352/XG-1352G) H 15 to 135 kHz/V 40 to 160Hz (XG-852/XG-852G) H 15 to 85 kHz/V 40 to 160Hz
Retrace time	H 6.0 μS (fH 15 to 30kHz) H 2.6 μS (fH 30 to 77kHz) H 2.0 μS (fH 77 to 120kHz) H 1.4 μS (fH 120 to 135kHz) V 270 μS
Video bandwidth	150MHz (-3dB) XG-1352/XG-1352G 110MHz (-3dB) XG-852/XG-852G
CRT	8 inch liquid cooled Deflection angle 90 degrees
Lens	Hybrid lens with ECP and ARC , F1.1 HD-134: XG-1352/XG-1352G HD-144N: XG-852/XG-852G (ECP: Enhanced Color Purity except B-lens/ARC: Anti-Reflective Coating)
Picture size	60 to 300 inches diagonal
Resolution	1500TV lines at center (HDTV) 1350TV line at corner (HDTV)
Pixel resolution	2500 × 2000 dots (Addressable) (XG-852/XG-852G: 1600 × 1200 dots)
Light output	240 ANSI lumens (XG-1352/XG-1352G, 230 ANSI lumens (XG-852/XG-852G)
High voltage	32kV
Input	RGB signal 0.7Vp-p 75 ohm positive (BNC) H/V sync 0.7 to 4.0Vp-p 75 ohm/High Z negative or positive (BNC) COMP sync 0.7 to 4.0Vp-p 75 ohm/High Z negative or positive (BNC) Sync on G 0.3 to 0.6Vp-p 75 ohm negative (BNC) COMP Video 1.0Vp-p 75 ohm positive (BNC) S-video: Y 1.0Vp-p 75 ohm positive C 0.28Vp-p 75 ohm (burst level) COMPONENT; 1.0Vp-p 75ohm negative (BNC) Cr,Cb 0.7Vp-p 75ohm (BNC) Video system NTSC, PAL, SECAM and NTSC4.43
Convergence	Digital convergence (Pre-set 100 positions) Quick copy convergence Static and wave convergence Point convergence, Zone convergence
Convergence limits	Less than 0.2% of V-height
Warm up time	20 minutes
Setup signal	Cross hairs, Cross hatch, Dot, Window Pattern, H test pattern
Power supply	AC 120V 60Hz (XG-1352/XG-852) AC 220-240V 50Hz (XG-1352G/XG-852G)
Power consumption	750W (XG-1352), 690W (XG-852) 730W(XG-1352G), 660W (XG-852)

Input current	6.7A (AC 120V)XG-1352 6.2A (AC 120V)XG-852 3.4A (AC 220-240V)XG-1352G 3.1A (AC 220-240V)XG-852G
Safety and regulation	XG-1352/XG-852; Meets FCC class A requirements UL Approved (UL 1950, CSA 950) DHHS Approved Meets DOC (Canada) Meets RED ACT XG-1352G/XG-852G; Meets EMC Directive (EN55022,EN61000-3-2, EN61000-3-3, EN50082-1) Meets Low Voltage Directive (EN60950, TÜV GS Approved) PTB Approved
Cabinet dimensions	610(W)X812(D)X325(H) mm 24.02(W)X31.97(D)X12.80(H) inch
Weight	63.0 kg/139.0 lbs(XG-852/XG-852G) 67.4 kg/148.7 lbs (XG-1352/XG-1352G)
Remote control	Wired application Wireless (operating distance 7m/23ft.)
Remote control functions	User remote (RC-6320); Power ON/OFF, Input signal select, Picture mute, Bright, Contrast, Color 1), Sharpness 1), Tint 2), Volume 3), Sound mute 3), Source information, Static convergence, Normal- ize, Enter, End, Closed Caption Full function remote (RC-6321); Test, Display, Help, Information, Input list, Static focus, Edge focus, H/ V position, White balance select, Static conver- gence, Wave convergence, Point convergence, H/V amplitude, H/V linearity, H/V key-stone, H/V pin- cushion, H/V blanking, Tilt, Skew, H/V bow, Store, Normalize, Enter, End
Main control function	Power ON/OFF, Input signal select,
External control	Power ON/OFF, Input signal select, Picture mute, Sound mute ³⁾ , Remote control data input
PC control	Acceptable
Supplied accessories	Full function remote control unit (RC-6321), User remote control unit (RC-6320), Remote cable 16m/52ft., AC line cable, Terminal cover, Operation manual, Set-Up manual*, Installation manual*
Environment	Temperature 0 to 40 degrees C Humidity 0 to 90% non-condensing Storage -10 to 50 degrees C
Sound emission	XG-1352/XG-852 less than 45dB XG-1352G/XG-852G less than 70dB (A). Complies with ISO 3744 or ISO 7779

- 1) This works only for VIDEO signals.
- 2) This works only for NTSC video signals.
- 3) This works only with the Switcher operation.

*Set-Up manual and Installation manual are not included
with XG-852G/XG-1352G.

Specifications are subject to change without notice.
The dimensions given for the projector do not include
protruding parts.

NEC
NEC Corporation

Printed in Japan
78409161

Free Manuals Download Website

<http://myh66.com>

<http://usermanuals.us>

<http://www.somanuals.com>

<http://www.4manuals.cc>

<http://www.manual-lib.com>

<http://www.404manual.com>

<http://www.luxmanual.com>

<http://aubethermostatmanual.com>

Golf course search by state

<http://golfingnear.com>

Email search by domain

<http://emailbydomain.com>

Auto manuals search

<http://auto.somanuals.com>

TV manuals search

<http://tv.somanuals.com>