

NEC

ND-91649 (E)
ISSUE 3

NEAX 2000 IPS

INTERNET PROTOCOL SERVER

General Description

NEC Corporation

LIABILITY DISCLAIMER

NEC Corporation reserves the right to change the specifications, functions, or features, at any time, without notice.

NEC Corporation has prepared this document for use by its employees and customers. The information contained herein is the property of NEC Corporation and shall not be reproduced without prior written approval from NEC Corporation.

NEAX and D^{term} are registered trademarks of NEC Corporation.

Copyright 2004

NEC Corporation

Printed in Japan.

All other brand or product names are or may be trademarks or registered trademarks of, and are used to identify products or services of their respective owners.

NEAX 2000 IPS General Description

TABLE OF CONTENTS

	Page
CHAPTER 1 INTRODUCTION	1
System Overview	1
Hardware Architecture	5
Software Architecture	7
CHAPTER 2 SYSTEM CONFIGURATION	10
Module Configuration	10
Installation Methods	11
Modules and Installation Hardware	14
Circuit Cards	15
System Conditions	15
CHAPTER 3 TERMINALS	17
Desk Console	18
Figures of D ^{term} Series i/D ^{term} IP	22
Wireless System	28
D ^{term} Softphone (SP30)	37
CHAPTER 4 OVERVIEW OF INSTALLATION, PROGRAMMING, AND MAINTENANCE	39
Installation	39
Programming	40
Maintenance	41
CHAPTER 5 SPECIFICATIONS	42
System Capacity	42
IP Specifications	45
Line Conditions	47
Cell Station/Zone Transceiver Line Conditions	48
Traffic Capacity	49
DRS (Device Registration Server)	49

LIST OF ILLUSTRATIONS

Figure	Title	Page
Figure 1-1	NEAX 2000 IPS.....	1
Figure 1-2	NEAX 2000 IPS System Overview.....	2
Figure 1-3	Example of Network Configuration of Remote PIM over IP	3
Figure 1-4	Retrofit MP/FP for Upgrading NEAX 7400 ICS M100 to IPS (Single MP System).....	4
Figure 1-5	Retrofit MP/FP for Upgrading NEAX 7400 ICS M100 to IPS (Dual MP System).....	4
Figure 1-6	Trunking Diagram of NEAX 2000 IPS	9
Figure 2-1	Module Configuration of NEAX 2000 IPS.....	10
Figure 2-2	Face Layout of NEAX 2000 IPS	11
Figure 2-3	Wall-mounting of PIM.....	12
Figure 2-4	19-inch Rack-mounting.....	13
Figure 3-1	DESK Console	18
Figure 3-2	D ^{term} 2 (White).....	22
Figure 3-3	D ^{term} 8 (White).....	22
Figure 3-4	D ^{term} 8D (White)	22
Figure 3-5	D ^{term} 16D (White)	23
Figure 3-6	D ^{term} 32D (White)	23
Figure 3-7	DSS Console (Black).....	23
Figure 3-8	D ^{term} 16LD (Black).....	24
Figure 3-9	Analog Port Adapter (APR)	24
Figure 3-10	Ancillary Device Adapter (ADA).....	24
Figure 3-11	Computer Telephony Adapter (CTA).....	25
Figure 3-12	IP Adapter (IPW)	25
Figure 3-13	System Configuration of Wireless Communications	29
Figure 3-14	Cell Station (CS), IP Base Station (IP-BS) and PHS Personal Station (PS).....	33
Figure 3-15	Zone Transceiver (ZT) and PCS Personal Station (PS).....	36
Figure 3-16	SP30 Screen.....	37

LIST OF TABLES

Table	Title	Page
Table 1-1	Technical Terms of NEAX 2000 IPS System	8
Table 2-1	Modules of NEAX 2000 IPS System	14
Table 3-1	D ^{term} Series i/D ^{term} IP Specifications and Accessories	26
Table 3-2	Combination Pattern of Optional Accessories to the D ^{term} Series i/ D ^{term} IP.....	27
Table 3-3	PHS Personal Station (PS) Specifications	30
Table 3-4	2-Wired (U-Interface) Cell Station (CS) Specifications	31
Table 3-5	IP Base Station (IP-BS) Specifications	32
Table 3-6	PCS Personal Station (PS) Specifications	34
Table 3-7	Zone Transceiver (ZT) Specifications	35
Table 5-1	System Capacity (Single MP System).....	42
Table 5-2	IP Specifications	45
Table 5-3	Line Conditions	47
Table 5-4	Cell Station/Zone Transceiver Line Conditions	48
Table 5-5	Traffic Capacity	49
Table 5-6	DRS (Device Registration Server)-System Based	49

CHAPTER 1 INTRODUCTION

This document provides an overview of the NEAX 2000 IPS (Internet Protocol Server) stored program control digital electronic PBX. An introduction to the technical characteristics is included, along with a description of available system applications.

System Overview

The NEAX 2000 IPS is a full-featured IP-based communications system providing a rich feature set of NEAX 7400 ICS M100MX*, with pure Voice over IP (VoIP) communications (peer-to-peer connections), across corporate Local and Wide Area Networks (LAN and WAN).



Figure 1-1 NEAX 2000 IPS

The NEAX 2000 IPS supports both pure IP switching (peer-to-peer connections) and Time Division Switching. The pure IP switching is provided for communications between D^{term}IPs and for CCIS connections with another NEAX 2000 IPS/2400 IPX (CCIS over IP). On the other hand, the TDM switching is provided for communication between legacy stations/trunks. Connections between D^{term}IP/CCIS over IP and legacy stations/trunks are made via IP PADs, which converts packet-based voice data to TDM-based voice data, and vice versa.

* "NEAX 7400 ICS M100MX" is marketed in North/Latin America and Australia as "NEAX 2000 IVS²" and in UK as "NEAX 2000 INTEGRATED VOICE SERVER."

INTRODUCTION

D^{term}IP telephones are designed to provide a converged infrastructure at the desktop, with a 100 Base T Ethernet connection to the LAN and built-in hub for a PC connection to the telephone itself. The system can provide peer-to-peer connections between D^{term}IP telephones with voice compression, on a CCIS basis (CCIS over IP).

PHS cell station can also be connected to LAN with 100 Base T Ethernet as IP-BS.

IPS also provide Windows PC based softphone (D^{term} Softphone SP30) to connect to LAN network and it provides IP enabled D^{term} features without the telephone set.

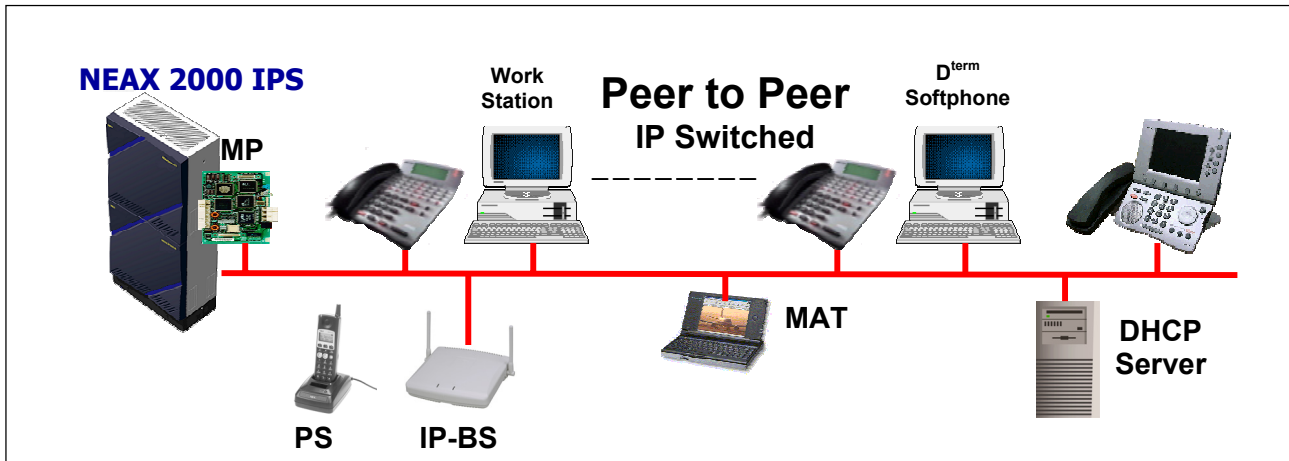

Figure 1-2 NEAX 2000 IPS System Overview

The NEAX 2000 IPS can also provide legacy station/trunk interfaces to support the existing Time Division Multiplexing (TDM) based infrastructure, such as analog telephones, analog networks, and digital networks (T1/E1, ISDN etc.). The legacy station/trunk interface cards (LT and AP cards) can be accommodated in the Port Interface Modules (PIM), in the same manner as the NEAX 7400 ICS M100MX*. At maximum configuration, total system capacity is 768 ports. The system can provide 512 ports for D^{term}IP telephones and legacy LT cards, and 256 ports for legacy AP cards. Communications between legacy station/trunks and D^{term}IP telephones/IP networks are made via IP PAD, which converts packet-based voice data to TDM-based voice data, and vice versa. Both peer-to-peer connections and TDM-based connections are controlled by a new Main Processor (MP) card. The new MP card incorporates a built-in Device Registration Server (DRS) and a single interface point of IP connections to IP telephone, MATWorX, and OAI/ACD servers.

All Application Processor cards used in NEAX 7400 ICS M100MX* except AP01 and CC01 cards are available for the IPS system. All Business/Hotel/Data/CCIS/ISDN/WCS features are available. The following service features are now included on the MP card and do not require the AP01 card.

- Authorization Code with AP01
- Forced Account Code with AP01
- Direct Inward System Access (DISA) with AP01 (For North America)/Remote Access to System with AP01 (For other than North America)
- Call Forwarding set by DISA with AP01

* "NEAX 7400 ICS M100MX" is marketed in North/Latin America and Australia as "NEAX 2000 IVS²" and in UK as "NEAX 2000 INTEGRATED VOICE SERVER."

Remote PIM over IP

NEAX 2000 IPS can install a PIM at remote site through IP network. At the main site, the NEAX 2000 IPS is installed and the Remote PIM is installed at remote site. The main site controls call processing and service feature access for station users located both main and remote sites. When the Remote PIM cannot be connected with the main site due to the IP network and/or main PBX failure, the Remote PIM initializes the system and re-starts operation by its own Main Processor (survival mode). In the survival mode, almost all service features are provided to the station users accommodated in Remote PIM. When IP network/main PBX is recovered, the Remote PIM can be restored to normal mode with system initialization by manual operation or automatically (Selectable by system data setting).

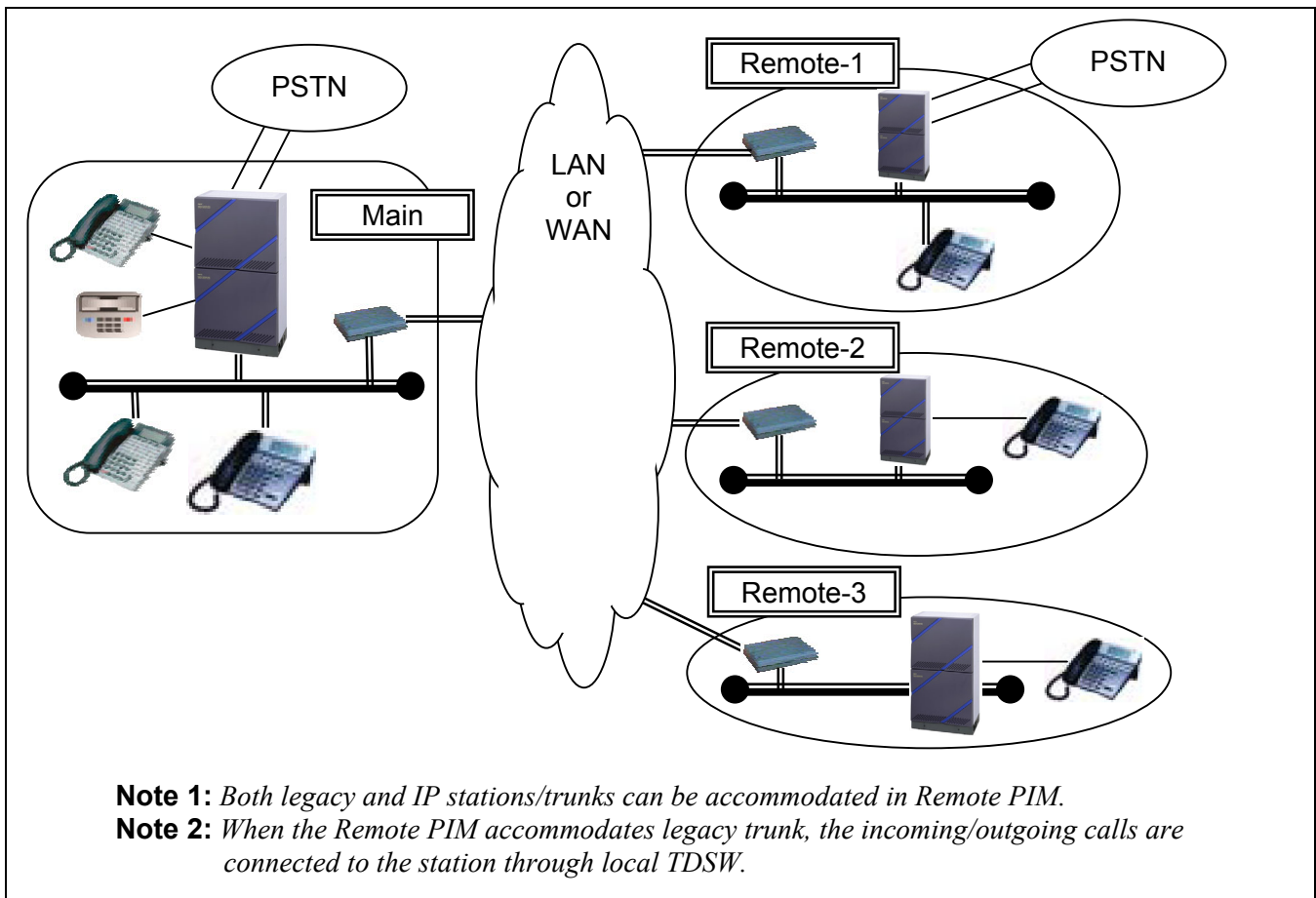

Figure 1-3 Example of Network Configuration of Remote PIM over IP

Migration Path

For customers who are using the NEAX 7400 ICS M100MX*, the migration path is supplied. By replacing the existing MP card to the new IPS MP card, the NEAX 7400 ICS M100MX* can be upgraded to IP/TSW Hybrid System including new and enhanced service features introduced with the NEAX 2000 IPS.

For customers who are using NEAX 7400 ICS M100*/M80VS, by replacing existing PN-CP00/CP03 with Retrofit MP and PN-CP01 with Retrofit FP, the NEAX 7400 ICS M100/M80VS can be upgraded to the NEAX 2000 IPS features. In case of NEAX 7400 ICS M100/M80VS Dual MP System the CP02 is replaced with CP28-A Retrofit Dual MP. (See the following figure showing replacement of control cards. As for the LT/AP card conditions after upgrading, refer to the “NEAX 2000 IPS Card Application List”.)

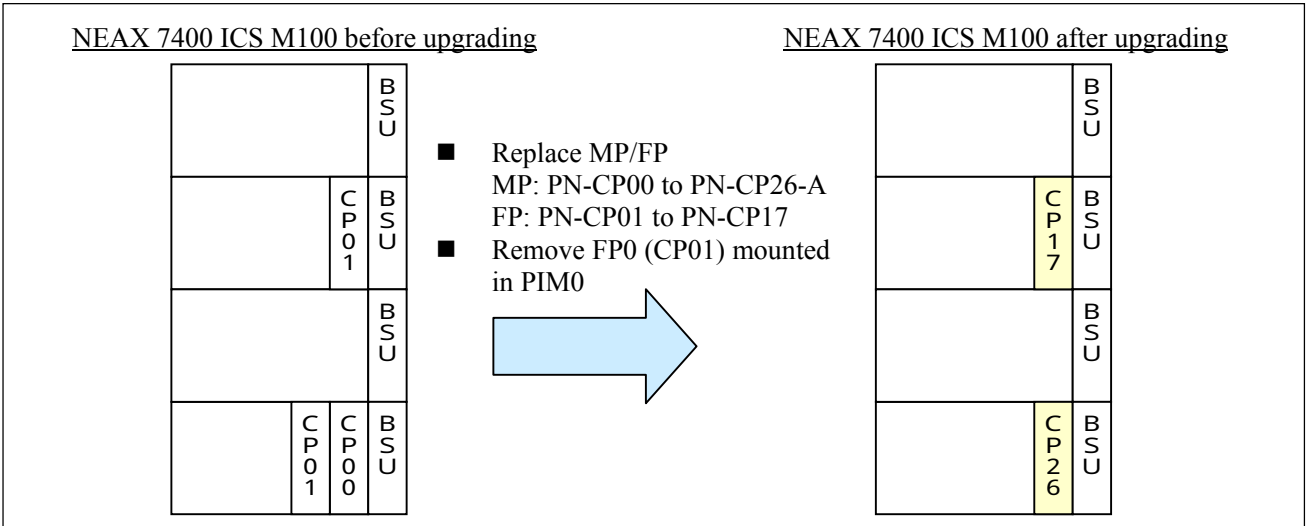

Figure 1-4 Retrofit MP/FP for Upgrading NEAX 7400 ICS M100 to IPS (Single MP System)

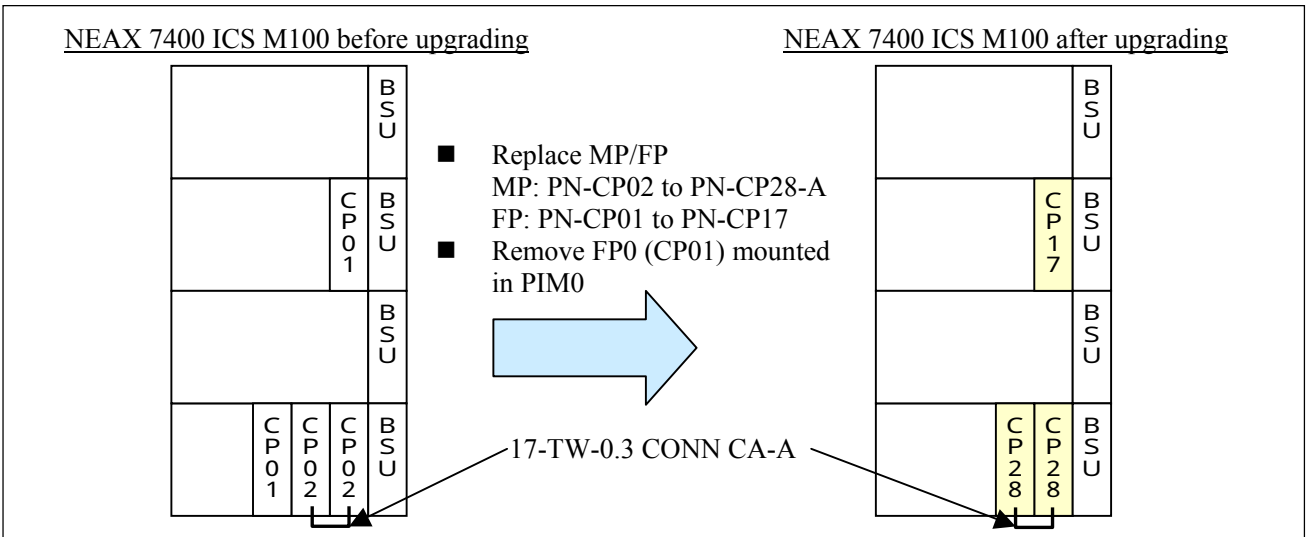

Figure 1-5 Retrofit MP/FP for Upgrading NEAX 7400 ICS M100 to IPS (Dual MP System)

* “NEAX 7400 ICS M100MX” is marketed in North/Latin America and Australia as “NEAX 2000 IVS²” and in UK as “NEAX 2000 INTEGRATED VOICE SERVER.”
 * “NEAX 7400 ICS M100” is marketed in North America as “NEAX 2000 IVS” and in Australia as “NEAX ICS 120”.
 * “NEAX 7400 ICS M80VS” is marketed in Australia as “NEAX ICS 110”.

Hardware Architecture

Reduced Hardware with IP-based Architecture

The D^{term}IPs, D^{term} Softphone and IP-BS connected to the LAN do not require any special interface cards* because they can be interfaced directly with the LAN and connected with peer-to-peer basis. When the D^{term}IP, D^{term} Softphone or IP-BS is connected to a station/trunk that is using TSW, the speech path between LAN and TSW is made via IP PAD under the call processing control of the MP. The D^{term}IP, D^{term} Softphone or IP-BS can be expanded simply adding the terminal itself. With this system architecture, the hardware such as DLC, CSI, CSH, PIM, Power Supply etc. is reduced and easy moves, adds, and changes can be realized.

Standard TDM Hardware	Peer-to-Peer IP Hardware
<ul style="list-style-type: none"> ▪ Line & Trunk Cards ▪ Application Processors ▪ Firmware Processors 	<ul style="list-style-type: none"> ▪ IP PAD (8IPLA, 24IPLA, 32IPLA, 16VCT) ▪ Ether Card (M606)

Powerful, One-board Main Processor (MP) with Integrated Functionality

The NEAX 2000 IPS Main Processor (MP) is the heart of pure IP connections and TDM-based connections. The MP employs a high-speed CPU, which is equivalent with Pentium. With this processing power and System On Chip (SOC) technology, the MP integrates Device Registration Server (DRS), AP01 (OAI) functions, which are provided by an additional card in the previous M100MX*. Also, by means of today's advanced LSI technology, the MP card size is minimized and On-board Ethernet Interface card is mounted on the MP without using an additional slot space in the PIM. This interface card is linked with LAN for call control processing of D^{term}IP and inter-work with MATWorX and OAI server.

Enhanced Built-in Firmware Processor (FP) on MP

The NEAX 7400 ICS M100MX* requires the FP card in PIM0 when the system is configured with 3 or more PIMs. In case of the NEAX 2000 IPS, the FP in PIM0 is not required since the Built-in FP function in new MP has been improved and it provides more call processing capability. (FP is used in PIM2, 4 and 6.)

* DLC, CSI and CS handler.

Extended Application Processor (AP) Port Capacity

The NEAX 2000 IPS provides a maximum of 256 AP ports and it is independent of the 512 ports for the Line/Trunk (LT), therefore, more AP cards such as T1/E1 digital link cards can be used in the system.

Universal Slot

One PIM provides 12 card slots for Line/Trunk (LT). Also, these card slots can be used for Application Processor (AP) cards without complicated limitation. This makes easy quotation and installation, and more AP cards can be mounted in one PIM.

Unified Circuit Card Size

All the circuit cards for the NEAX 2000 IPS are designed in one size (PN-type), and installed in the PIM. This maximizes the efficiency of slot utilization of the PIM.

High Density Line/Trunk Cards

The major line/trunk cards used in the NEAX 2000 IPS are provided with 8 circuits per card. This allows the physical system size to be compact.

Various Power supply system

- AC Input system
The PIM houses the AC/DC power supply with various AC (100V/200V) input that outputs various DC voltage required for several internal cards.
The AC/DC power supply has function of Battery charger. Thus, system can be backed up with battery according to necessity.
The PIM also houses optional DC/DC power supply for the cards that require -48V power such as CSI card used for interface of cell station/zone transceiver.
- DC Input system
NEAX 2000 IPS also provides the DC/DC power supply with -48V DC input house in the PIM that outputs various DC voltage required for several internal cards.
Thus, NEAX 2000 IPS can be installed at various powering environment.

Various Installation Methods

To meet the specific needs of the customer's environment, the NEAX 2000 IPS provides the following installation methods:

- Floor Standing Installation
- Wall-mounting Installation
- IEC standard 19-inch Rack-mounting Installation

Software Architecture

Built-in DRS (Device Registration Server) on MP

The NEAX 2000 IPS incorporates DRS (Device Registration Server) on the MP. DRS provides Log-in/Log-out management of D^{term}IP including Registration and Authentication. Also, the built-in DRS can be inter-worked with DHCP server to provide easy administration on IP address.

Office Data Backup Enhancement

The office data of the NEAX 2000 IPS is stored in Flash ROM, therefore the backup period is extended compared with previous M100MX series which were using RAM with battery.

* M100MX is marketed in North/Latin America and Australia as “NEAX 2000 IVS²” and in UK as “NEAX 2000 INTEGRATED VOICE SERVER.”

Technical Terms

Table 1-1 Technical Terms of NEAX 2000 IPS System

SYMBOL	DESCRIPTION	SYMBOL	DESCRIPTION
AMP	Amplifier Trunk Card	LC	Line Circuit Card (for Single Line Telephone)
AP00	SMDR/Hotel Application Card	LDT	LD Trunk Card
BGM	External Music Source for Dterm Back Ground Music Service	LLC	Long Line Circuit Card
BRT	Basic Rate Interface Trunk Card	M10	Optical Interface Card
CCH	Common Channel Handler Card	MAT	Maintenance Administration Terminal
CFT	6/10 Party Conference Trunk Card	MDF	Main Distribution Frame
CIS	Call Information System	MEM	Main Memory
CIR	CALLER ID Receiver Trunk Card	MFR	MF Receiver/ MFC Receiver/Sender Card
COT	C.O. Trunk Card	MLDT	Melody Trunk
CSI	CS/ZT Interface Card	MODEM	Modem
CS/ZT	Cell Station (For Australia/Others) Zone Transceiver (For North America/ Latin America)	MP	Main Processor Card
DAT	Digital Announcement Trunk Card	PFT	Power Failure Transfer
DCH	D-channel Handler Card	PMS	Property Management System
DIT	DID Trunk Card	OAI	Open Application Interface
DK	External Relay/Key Interface Card	ODT	OD Trunk Card (2/4 wire E&M)
DLC	Digital Line Circuit Card (for Dterm, ATTCON, DESKCON)	PBR	PB Receiver Card
DSS	DSS Console	PBSND	PB Sender
DTI	Digital Trunk Interface Card	PLO	Phase Locked Oscillator
DTG	Digital Tone Generator	PS	Personal Station
ETHER	Ethernet Control Card	PRT	ISDN Primary Rate Interface Trunk Card
ICH	ISDN-channel Handler Card	SMDR	Station Message Detail Recording
ILC	ISDN Line Circuit Card	TDSW	Time Division Switch
IP-BS	IP Base Station	TNT	Tone/Music Source Interface Card
IP PAD	IP Packet Assembler/Disassembler Card	VCT	CODEC Card
IPT	IP Trunk Card	VM	Voice Mail Card
KEY	External Key	16CFT	16-Circuit Four-Party Conference Trunk

Trunking Diagram

This figure shows a typical trunking diagram of the NEAX 2000 IPS system.

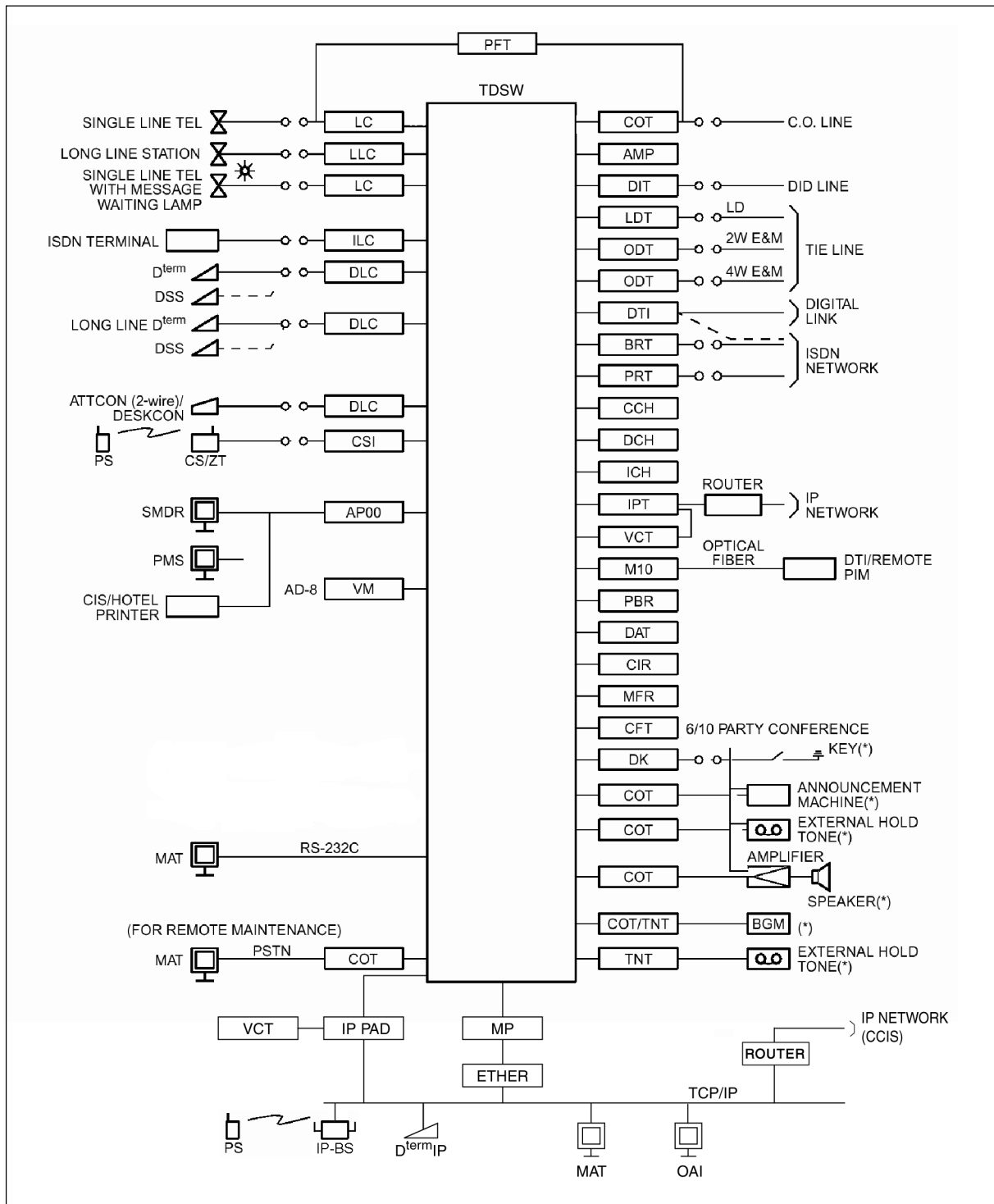

Figure 1-6 Trunking Diagram of NEAX 2000 IPS

CHAPTER 2 SYSTEM CONFIGURATION

Module Configuration

The NEAX 2000 IPS consists of Port Interface Modules (PIM) depending on the system configuration, and there are two types of PIMs; “Physical” PIM and “Virtual” PIM.

The Physical PIM is a “hardware” PIM and is used to accommodate an MP, FPs, IP PADs, legacy LT an AP cards, and power supply units. One Physical PIM provides up to 64 ports.

The Virtual PIM is a “software” PIM and is used to assign D^{term}IP telephones, D^{term} SP30 or IP-BS by system programming. One Virtual PIM provides up to 64 D^{term}IP telephones. The system consists of up to 8 PIMs, by the combination of Physical PIMs and Virtual PIMs, thus providing 448 ports for D^{term} IP telephones and 512 ports for legacy LT cards. The total number of ports for D^{term}IP telephones and legacy LT cards must be 512 or fewer, so that the number of Physical PIMs decreases when that of Virtual PIMs (= number of D^{term}IP telephones) increases. For example, when 256 legacy LT ports are required (= four Physical PIMs), the maximum number of D^{term} IPs is 256.

The figure below shows examples of 512-port configuration by combination of legacy LT ports and D^{term} IP telephones.

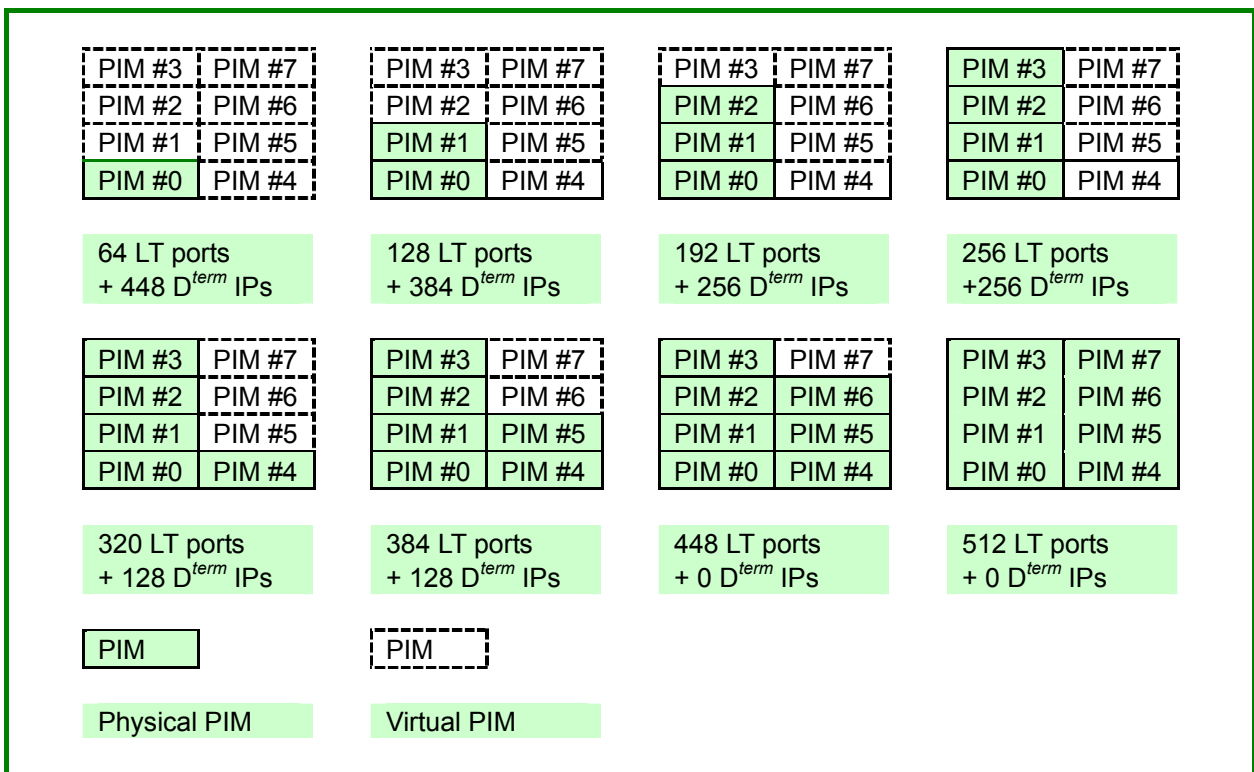

Figure 2-1 Module Configuration of NEAX 2000 IPS

Installation Methods

The NEAX 2000 IPS provides three installation methods as follows:

- Floor Standing Installation
- Wall Mounting Installation
- 19-inch Rack Mounting Installation

Floor Standing Installation

In Floor Standing Installation, the NEAX 2000 IPS is comprised of up to 8 Port Interface Modules (PIMs).

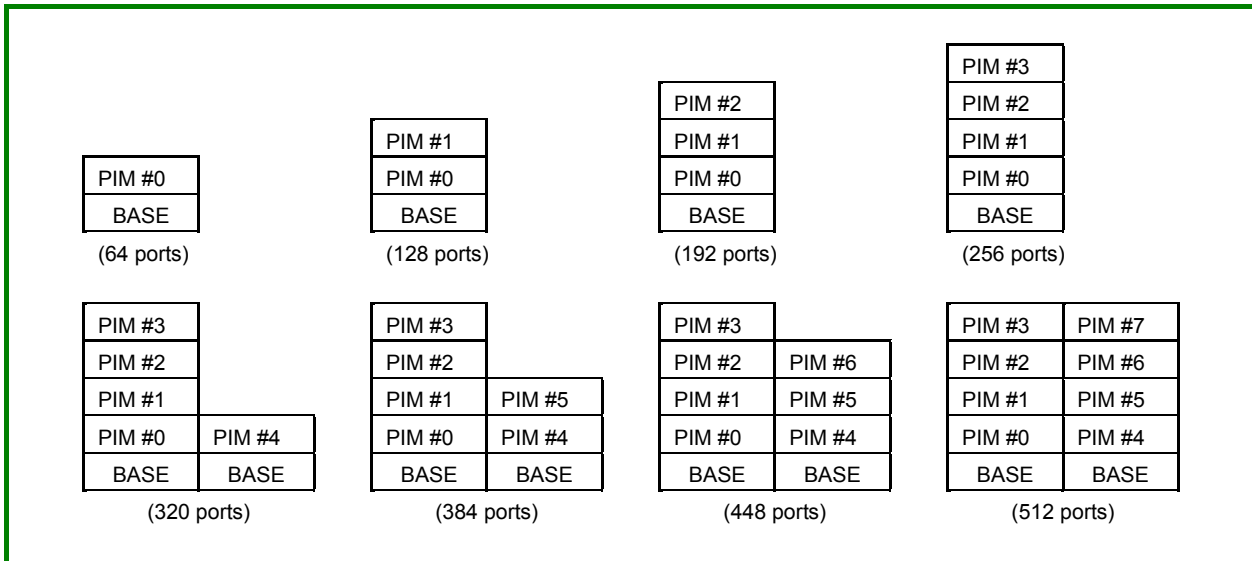

Figure 2-2 Face Layout of NEAX 2000 IPS

Wall-mounting Installation

The NEAX 2000 IPS can be wall-mounted with single or multiple PIM (MAX. 8) configuration.

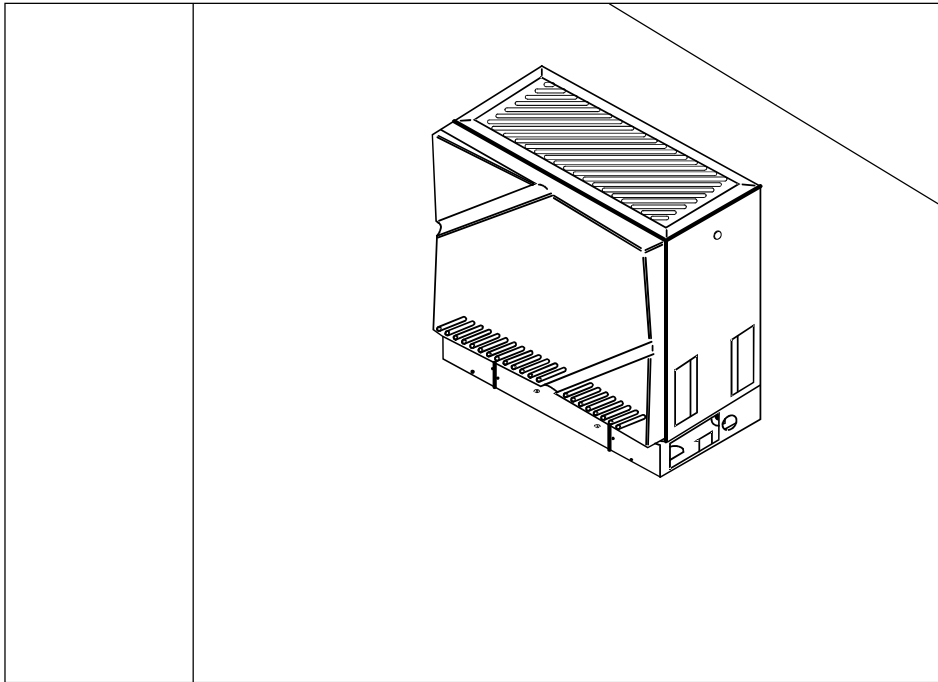

Figure 2-3 Wall-mounting of PIM

19-inch Rack-mounting Installation

The NEAX 2000 IPS can be mounted in the IEC-standard 19-inch rack up to 4 PIMs. (IEC: International Electro-technical Commission)

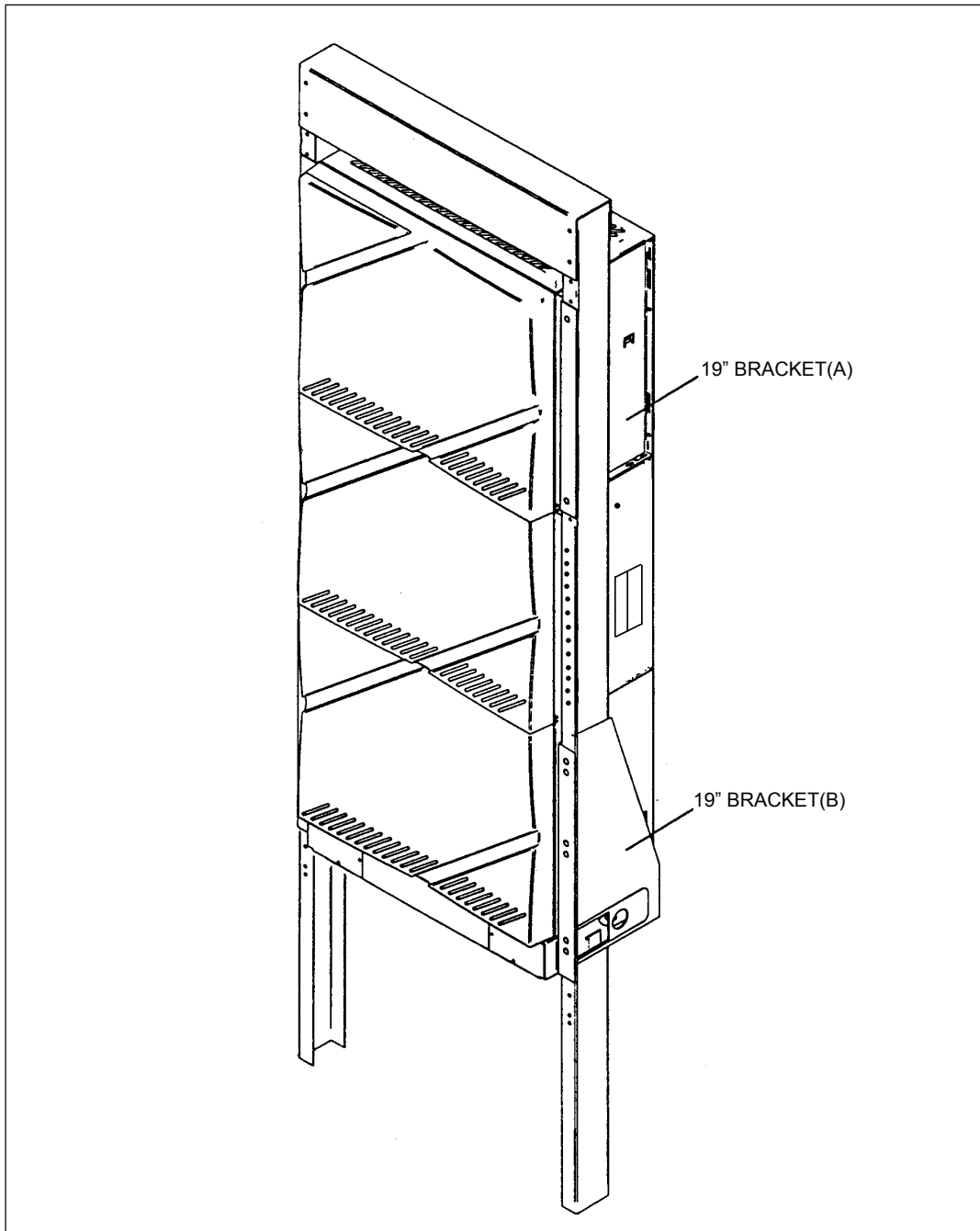

Figure 2-4 19-inch Rack-mounting

Modules and Installation Hardware

The NEAX 2000 IPS is comprised of up to 8 Port Interface Modules (PIMs).

Modules

(1) Port Interface Module (PIM)

A PIM provides 13 card slots for common control, Line/Trunk (LT), and Application Processor (AP) cards. It also houses an AC/DC Power Supply (or DC/DC Power Supply), optional DC/DC Power Supply (for -48V), and batteries for protection from short-term (about 30 min.) power interruption.

Four champ connectors for Line/Trunk (LTC 0 to 3) are located at the lower front side of the PIM.

A PIM provides a maximum of 12 card slots for Line/Trunk (LT) and Application Processor (AP) cards. At maximum configuration, the system is comprised of 8 PIMs.

PIM MD (PIM3)	PIM MD (PIM7)
PIM MD (PIM2)	PIM MD (PIM6)
PIM MD (PIM1)	PIM MD (PIM5)
PIM MD (PIM0)	PIM MD (PIM4)

Single MP System

PIM MD (PIM3)	PIM MD (PIM7)
PIM MD (PIM2)	PIM MD (PIM6)
PIM MD (PIM1)	PIM MD (PIM5)
PIM MF (PIM0)	PIM MD (PIM4)

Dual MP System

(2) Battery Module (BATTM)*

The BATTM is an optional module for installing optional long-term (about 3 hours) backup batteries. The BATTM is designed to accommodate batteries covering up to a 4-PIM system (2 BATTM's support maximum system configuration).

The BATTM is available for Floor Standing Installation. (When the system is Wall-mounting/19-inch Rack-mounting configuration, the BATTM cannot be installed with the PIM.)

Table 2-1 Modules of NEAX 2000 IPS System

Abbrev	Name Code	Remarks
PIMMD	SN1617 PIMMD	PIM 0 ~ PIM 7
PIM MF	SN1658 PIMMF	PIM0 for dual MP system
BATTM	SN1619 BATTM	1/STACK, Max.2/system

* Battery Module is available for Latin America.

Circuit Cards

The circuit cards used for NEAX 2000 IPS are divided into the following three types. According to these card types, the mounting location of card and port allocation of the Time Division Switch are varied.

- Common Control Cards
 - Main Processor (MP)
 - Firmware Processor (FP)
- Line/Trunk (LT) Cards
 - IP PAD, Line Circuit (LC), Central Office Trunk (COT), Tie Line Trunk (LDT/ODT), etc.
- Application Processor (AP) Cards
 - SMDR/PMS/CIS/Hotel Printer Interface (AP00)
 - T1/E1 Digital Trunk Interface (DTI)

System Conditions

Conditions for Peer-to-Peer Connection

- For the communication between D^{term} IPs, the voice data is transmitted and received directly, without converting voice packets into PCM and voice compression in the system.

Conditions for CCIS Connection

- D^{term} IP to D^{term} IP connection (Peer-to-Peer connection) via CCIS is available only when the destination office uses NEAX 2000 IPS or NEAX 2400 IPX.
- The built-in CCH-IPT of MP card can be connected to max. 127 trunks.
- The system provides only Point-to-Multipoint connection.

Conditions for H.323 Connection

- When connecting to the IP network with H.323 protocol, the IPT card is required.
- When connecting to the IP network with H.323 protocol, the voice data is transmitted and received via the IP-PAD card.

Conditions for Legacy Interface (LT/AP)

- All Application Processor cards used in NEAX 7400 ICS M100MX* except AP01 and CC01 cards are available for the system.
- All Line/Trunk cards used in NEAX 7400 ICS M100MX* are available for the system.

* "NEAX 7400 ICS M100MX" is marketed in North/Latin America and Australia as "NEAX 2000 IVS²" and in UK as "NEAX 2000 INTEGRATED VOICE SERVER."

Conditions for Maintenance

- MATWorX can be used as the maintenance program for NEAX 2000 IPS. Direct connection (RS-232C), Modem connection and LAN (TCP/IP) connection are available to connect to the MAT (Maintenance Administration Terminal).

Conditions for DRS

DRS = Device Registration Server

- The D^{term} IP registration is executed by the DRS-System Based. The DRS-Network Based is not available for the D^{term} IP registration.
- The DRS can be used as the Proxy server.

CHAPTER 3 TERMINALS

A variety of terminal equipment may be connected to the NEAX 2000 IPS. The following equipment may be installed with the system.

- Attendant Console
 - Desk Console
- D^{term} Series i
 - D^{term} 2 (White/Black Color) : 2-button terminal
 - D^{term} 8 (White/Black Color) : 8-button terminal
 - D^{term} 8D (White/Black Color) : 8-button terminal with LCD display
 - D^{term} 16D (White/Black Color) : 16-button terminal with LCD display
 - D^{term} 32D (White/Black Color) : 32-button terminal with LCD display
 - D^{term} 16 LD (White/Black Color) : 16-button LD terminal with LCD display
- D^{term} IP
 - D^{term} 8D (White/Black Color) : 8-button terminal with LCD display
 - D^{term} 16D (White/Black Color) : 16-button terminal with LCD display
- PS (Wireless Handset)
 - PHS model
 - PCS model
- D^{term} SP30 (or D^{term} SP20) (IP Softphone)

Desk Console

The SN716 Desk Console has an ergonomic design and provides full access to all PBX Console features. It connects to the NEAX 2000 IPS using the same circuit cards as the D^{term} 75 Series terminals. The SN716 Desk Console operates on a switched-loop basis with a maximum of 6 Attendant loops terminating at each console on the associated Interface card. The Attendant uses these loops for answering, originating, holding, extending, and reentering calls. When Attendant loop release is used, the number of loops is effectively increased to a maximum of 12 for each console.

The NEAX 2000 IPS supports a maximum of eight SN716 DESK Consoles.



SN716 DESKCON Features

- Character LCD (4x40 characters)
- LCD designation strips
- Software-controlled LCD loop key
- Full access to PBX features
- Headset connectivity
- Recorder connectivity

Figure 3-1 DESK Console

D^{term} Series i/D^{term} IP Digital Multifunction Terminals

The D^{term} Series digital multifunction/multiline terminal is available in two colors to meet the needs of various users based on the features and types of communications each end user requires.

D^{term} Series i

D ^{term} 2 (White/Black Color)	:	2-button terminal
D ^{term} 8 (White/Black Color)	:	8-button terminal
D ^{term} 8D (White/Black Color)	:	8-button terminal with LCD display
D ^{term} 16D (White/Black Color)	:	16-button terminal with LCD display
D ^{term} 32D (White/Black Color)	:	32-button terminal with LCD display
D ^{term} 16LD (White/Black Color)	:	16-button LD terminal with LCD display

D^{term} IP

D ^{term} 8D (White/Black Color)	:	8-button terminal with LCD display
D ^{term} 16D (White/Black Color)	:	16-button terminal with LCD display

Features most commonly used in daily operation and functions required by the user are provided by the following dedicated buttons/lamp.

- ◆ **Hold** - Press key to place an internal or external call on hold.
- ◆ **TRANSFER** - Allows the station user to transfer established calls to another station without attendant assistance.
- ◆ **ANSWER** - When LED on this key is lighted, press key to answer a waiting call.
- ◆ **SPEAKER** - Controls the built-in speaker that can be used for Hands Free Dialing/Monitoring and Voice Call.
- ◆ **REDIAL** - Press key to activate the redial feature, then press redial and scroll back through numbers that have been dialed. When desired number is displayed, press the key to activate dialing.
- ◆ **CONF** - Press key to establish a three-way conversation.
- ◆ **RECALL** - Press key to terminate established call and returns to the internal dial tone.
- ◆ **FEATURE** - Used to activate terminal setup functions and to program One-Touch Speed Dial/Feature Keys.
- ◆ **DIRECTORY** - Press key to activate speed calling.
- ◆ **MESSAGE** - Press key to access the voice mail system.
- ◆ **MIC** - Press key to respond hands free. LED on this key lights during speakerphone operation.

This ergonomically designed terminal provides; larger keypad buttons for dialing convenience, an expanded three-line by 24-character LCD display, tiltable legs with nonskid feet, and a highly visible call/message indicator lamp.

All models have built-in hands-free unit as standard. The terminal is connected to the NEAX 2000 IPS via a single pair of cabling, thus optimizing existing cabling environment. These advantages make the D^{term} Series i terminals the standard for telephones that effectively meet today's business requirements.

D^{term} Series i/D^{term} IP Lineup**◆ D^{term} 2 (2-button D^{term})**

This D^{term} Series Digital Multi-line Terminal is equipped with 8 dedicated Function keys (such as Hold, TRANSFER, ANSWER, SPEAKER, REDIAL, CONF, RECALL and FEATURE), 2 programmable Line/Feature keys (each with a two-color LED). 2 programmable keys are flexible and can be assigned to any outside line connected to the system, to another station line, or as a feature button. The terminal is available in two colors - Black (BK) and Ivory White (WH).

◆ D^{term} 8 (8-button D^{term})

This D^{term} Series Digital Multi-line Terminal is fully modular with 11 dedicated Function keys, 8 programmable Line/Feature keys (each with a two-color LED), built-in Speakerphone, built-in Headset Jack, Tone/Volume/Contrast control, Tilt Stand, and a large LED to indicate incoming calls and messages. The terminal is available in two colors - Black (BK) and Ivory White (WH).

◆ D^{term} 8D (8-button D^{term} with Display)

This D^{term} Series Digital Multi-Line Terminal is equipped with 11 dedicated Function keys, 8 programmable Line/Feature keys (each with a two-color LED), built-in Speakerphone, built-in Headset Jack, Tone/Volume/Contrast control, Tilt Stand, 3 line by 24-character LCD Display Panel (adjustable & detachable), four Soft Keys, and a Large LED to indicate incoming calls and messages. This terminal is available in two colors - Black (BK) and Ivory White (WH).

◆ D^{term} 16D (16-button D^{term} with Display)

This D^{term} Series Digital Multi-Line Terminal is equipped with 11 dedicated Function keys, 16 programmable Line/Feature keys (each with a two-color LED), built-in Speakerphone, built-in Headset Jack, Tone/Volume/Contrast control, Tilt Stand, 3 line by 24-character LCD Display Panel (adjustable & detachable), four Soft Keys, and a Large LED to indicate incoming calls and messages. This terminal is available in two colors - Black (BK) and Ivory White (WH).

◆ D^{term} 32D (32-button D^{term} with Display)

This D^{term} Series Digital Multi-Line Terminal is equipped with 11 dedicated Function keys, 32 programmable Line/Feature keys (each with a two-color LED), built-in Speakerphone, built-in Headset Jack, Tone/Volume/Contrast control, Tilt Stand, 3 line by 24-character LCD Display Panel (adjustable & detachable), four Soft Keys, and a Large LED to indicate incoming calls and messages.

◆ D^{term} 16LD (DESI Less 16 LD button D^{term} with Display)

This D^{term} Series Digital Multi-Line Terminal is equipped with 11 dedicated Function keys, 16 programmable Line/Feature keys (each with a two-color LED), built-in Speakerphone, built-in Headset Jack, Tone/Volume/Contrast control, Tilt Stand, 3 line by 24-character LCD Display Panel (adjustable & detachable), four Soft Keys, and a Large LED to indicate incoming calls and messages. This terminal is available in two colors - Black (BK) and Ivory White (WH).

D^{term} Series i/D^{term} IP Accessories

◆ Direct Station Selection (DSS) Console

This Console is equipped with 60 programmable line keys (each with a two-color LED). These keys can be programmed as Direct Station keys, Function keys, or Line keys. The DCU-60 Console is available in two colors - Black (BK) and Ivory White (WH).

◆ Analog Port Adapter (APR)

The Analog Port Adapter with Ringing (APR-U) provides an interface for installing single line telephones (SLTs), modems*. By installing the APR-U, calls may be initiated via a PC modem and switched to voice operation if desired. Data calls at a maximum speed of 28.8 kbps are also supported through the APR-U. The APR-U also has the added benefit of detecting incoming ringing signals. By providing ring detection, the user may wish to install a personal fax machine or an answering machine at the workstation and connect them through the D^{term} Series instrument for convenience.

* When a modem is installed to the D^{term} Series Multi-line terminal with the APR-U, the modem and the D^{term} Series Multi-line Terminal (handset, speakerphone, headset) cannot be used simultaneously.

◆ Ancillary Device Adapter (ADA)

The Ancillary Device Adapter (ADA-U) allows for a direct connection from the D^{term} Series i/ D^{term} IP terminal to a tape recorder for logging/recording telephone calls. A dedicated set of input connectors is also provided for a recording tone unit to inform the parties that the call is being recorded. The ADA-U does ***not*** require an AC adapter.

◆ Computer Telephony Adapter (CTA)

The Computer Telephony Adapter (CTA) provides D^{term} with a connection to desktop PC, allowing users to operate Windows[®]-based Computer Telephony application such as ClientPhone 32.

◆ IP Adapter (IPW)

The IP Adapter Unit (IPW) provides two 10/100 Base-T Ethernet ports to the Local Area Network (LAN) and a built-in switching hub for a PC connection to the adapter itself.

Operating power can be fed by either an AC/DC adapter unit or a power patch panel connected to the LAN switch/hub.

When the IPW is attached to the D^{term}, other optional accessories cannot be attached except for Ancillary Device Adapter (ADA).

◆ Wall Mount Unit (WMU)

The Wall Mount Unit (WMU) allows the D^{term} Series terminal to be conveniently mounted vertically when desk space is not available.

Figures of D^{term} Series i/D^{term} IP



* D^{term} 2 (Black) is also supported.

Figure 3-2 D^{term} 2 (White)



* D^{term} 8 (Black) is also supported.

Figure 3-3 D^{term} 8 (White)



* D^{term} 8 D(Black) is also supported.

Figure 3-4 D^{term} 8D (White)



* D^{term} 16 D (Black) is also supported.

Figure 3-5 D^{term} 16D (White)



* D^{term} 32 D (Black) is also supported.

Figure 3-6 D^{term} 32D (White)



* DSS Console (White) is also supported.

Figure 3-7 DSS Console (Black)



* D^{term} 16LD (White) is also supported.

Figure 3-8 D^{term} 16LD (Black)

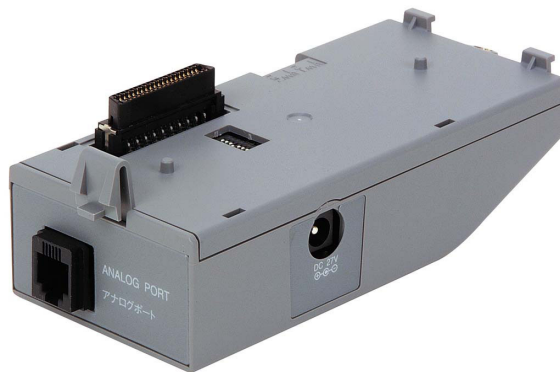

Figure 3-9 Analog Port Adapter (APR)

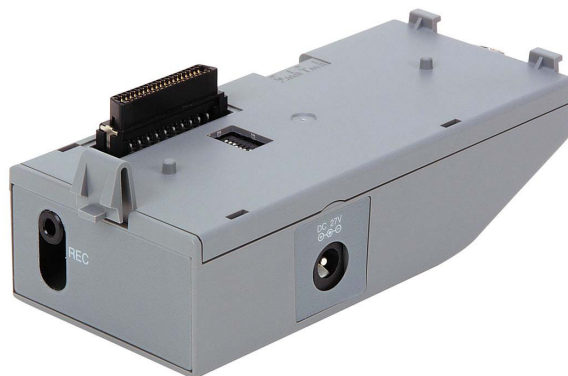

Figure 3-10 Ancillary Device Adapter (ADA)

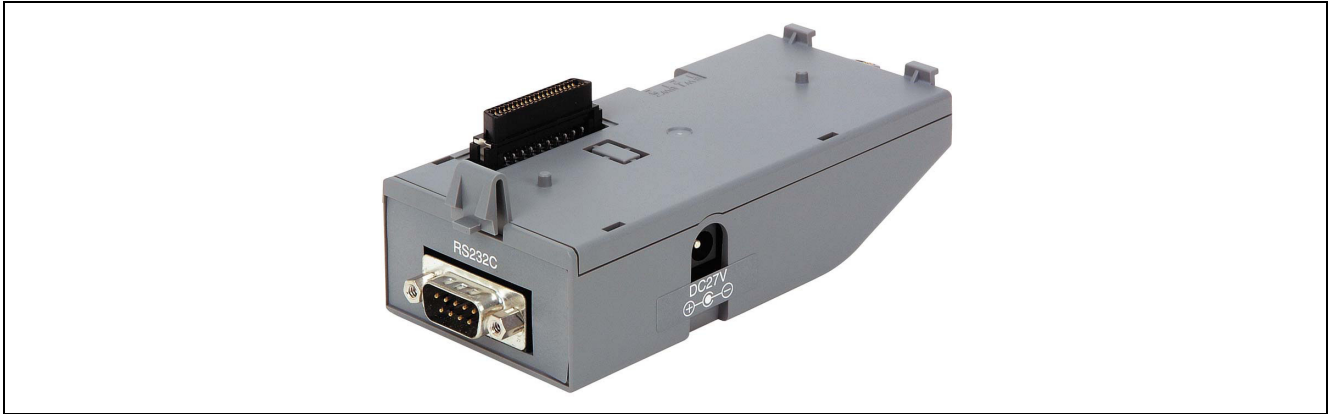

Figure 3-11 Computer Telephony Adapter (CTA)



Figure 3-12 IP Adapter (IPW)

TERMINALS

D^{term} Series i/D^{term} IP Specifications

The specifications of the D^{term} Series i/D^{term} IP are shown in below.

Table 3-1 D^{term} Series i/D^{term} IP Specifications and Accessories

Specifications/Description	D ^{term} 2	D ^{term} 8	D ^{term} 8D		D ^{term} 16D		D ^{term} 32D	D ^{term} 16LD
			D ^{term} Series i	D ^{term} IP	D ^{term} Series i	D ^{term} IP		
Dedicated Function Keys	8	11	11		11		11	11
Line/Feature Access/Programmable Feature Access Key	2	8	8		16		32	16
LCD	None	None	3 Lines 24 Characters		3 Lines 24 Characters		3 Lines 24 Charac- - ters	3 Lines 24 Charac- - ters
Indication on Line/Feature Keys	-	-	LED (Green /Red)	LED (Green /Red)	LED (Green /Red)	LED (Green /Red)	LED (Green /Red)	LCD** Icon
Hands Free Operation: Half Duplex	Yes	Yes	Yes	-	Yes	-	Yes	Yes Optional
Call/Message Indicator	Yes	Yes	Yes		Yes		Yes	Yes
Adjustable Legs (Built-in WMU)	No	Yes	Yes		Yes		Yes	Yes
Volume Control Handset (Receiver)	Yes	Yes	Yes		Yes		Yes	Yes
Volume Control Speakerphone (Receiver)	Yes	Yes	Yes		Yes		Yes	Yes
Volume Control Handset (Receiver)	Yes	Yes	Yes		Yes		Yes	Yes
Ring Volume Control	Yes	Yes	Yes		Yes		Yes	Yes
Brightness Control-LCD Contrast	-	-	Yes		Yes		Yes	Yes
Housing Color	White or Black	White or Black	White or Black		White or Black		White or Black	White or Black
Soft Keys	No	No	Yes		Yes		Yes	Yes
Optional Accessories								
DSS/BLF console*	No	Yes	Yes	No	Yes	No	Yes	Yes
Ancillary Device Adapter (ADA-U)	No	Yes	Yes	No	Yes	No	Yes	Yes
Analog Port Adapter w/ Ringing (APR-U)	No	Yes	Yes	No	Yes	No	Yes	Yes
PC Telephony Adapter (CTA)*	No	Yes	Yes	No	Yes	No	Yes	Yes
IP Adapter (IPW)*	No	No	Yes	No	Yes	No	Yes	Yes

* It requires an AC/DC adapter.

** Displayed characters are Only English.

Table 3-2 Combination Pattern of Optional Accessories to the D^{term} Series i/ D^{term} IP

Combination Pattern	APR	ADA	CTA	IPW	WMU
1		X			X
2					X
3	X				X
4			X		X
5				X	X
6		X			X
7	X	X			X
8		X	X		X
9			X		X
10	X		X		X

X : Available

Wireless System

A mobile work force no longer has to be dependent on special technology.

With personal telephone and Wireless Communication System, employees can travel throughout a multistored building or across a large industrial complex and continue to stay in constant touch with customers and colleagues.

NEAX 2400 IPX has built-in wireless system for providing wireless communication, it can support up to 256 users.

Versatile Communication Tool for a variety of industries

(1) Business Offices

Even when an employee in the company cannot be reached at their desk, the wireless communication service can put them in touch immediately.

A call from a customer can be connected directly to the called employee without holding the call or asking the customer to call back. This means improved customer satisfaction.

Even when a company has offices in several different buildings, just install the connection unit, then all you have to do is carry the handy phone set to place or receive calls anywhere. Since the wireless communication service does not require reinstallation of equipment or re-registration of extension numbers whenever you change the office layout, it can effectively reduce costs.

(2) Medical Centers (or Hospitals)

By assigning a personal handy phone to each doctor and nurse, they can be reached anywhere in the hospital for faster response to emergencies.

Better service can be offered to in-patients as well as patients with walking disabilities by lending them handy phone sets.

Speedier communications is an extra touch that will make the patients reassured that they are in good hands.

(3) Plants

The wireless communication service allows bi-directional communications in large working areas such as plants, warehouses, and factories.

Instructions and messages from the office or reports from the plant can be conveyed in real-time to help improve productivity.

The wireless service also makes it possible to verify the process while moving over a line or to check the inventory in the warehouse with someone in the office over the telephone.

Use the optional headset for hands-free communications without work interruptions for better safety and work efficiency.

(4) Department Stores and Hotels

On the sales floor, the wireless communication service allows a clerk to check inventory for a customer or promptly call the manager. When holding an event or exhibition, or when changing the sales floor layout, the wireless service requires no cable laying or transfer, so telephone installation and removal are simple.

At hotels and resorts, the wireless communication service can be used between the front desk and the rest of the complex and for communications and instructions between staff members of an event in the complex.

Assign each security guard a handy phone set, and you can realize more systematic reporting and higher mobility, as well as higher security in the event of an emergency.

System Configuration

Figure 3-13 shows the system configuration of NEAX 2000 IPX wireless communications system.

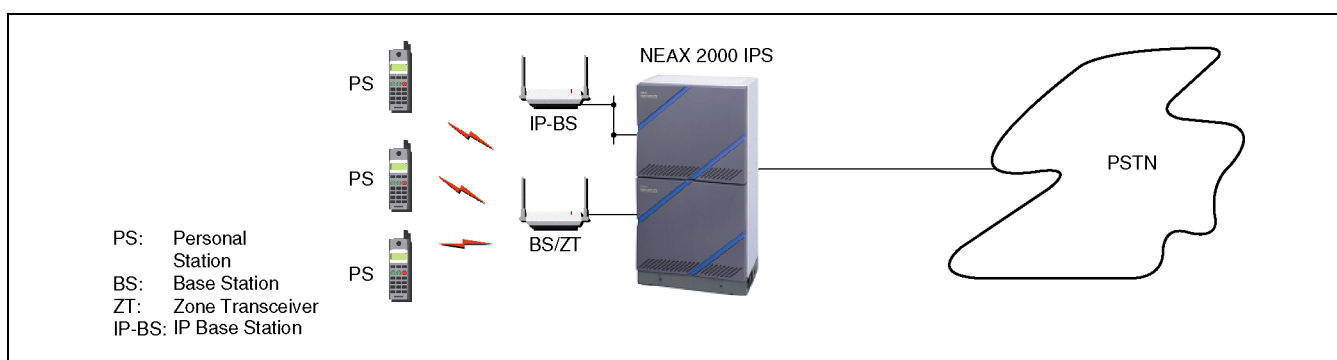

Figure 3-13 System Configuration of Wireless Communications

The wireless communications function conforms to the ARIB standard version 2 RCR STD-28 standardized in Japan as the PHS (Personal Handyphone System) or TIA/EIA-667 PACS WUPE standardized in USA as the unlicensed PCS (Personal Communications System) in accordance with market's regulations.

The PS (Personal Station), BS/ZT (Base Station/Zone Transceiver), IP-BS (IP Base Station) and the NEAX 2000 IPS provide wireless communications service on the private use.

Personal Handyphone System (PHS)

◆ **Personal Station (PS)**

The PS (Personal Station) incorporates the 32 Kbps ADPCM encoding technique and privacy function so that you can talk about even important matters in a noise-free, very clear voice.

Since the PS is light-weight and compact in size, it can conveniently carried around.

Here are specifications for the PS and its major functions.

Specification of Personal Station

Table 3-3 PHS Personal Station (PS) Specifications

Item	Specifications
Frequency	1.895 ~ 1.918 GHz
RF Power	10mW (Average)
Voice Coding/Decoding System	32 Kbps ADPCM
Basic Specifications	Compliance with ARIB Standard RCR STD-28 version 2
Continuous Talk Time	Approx. 6 Hours
Continuous Standby Time	Approx. 500 Hours
Waterproof	Supported
Dimensions	Approx. 40 (W) × 24 (D) × 130 (H) mm (Excluding Antenna)
Volume	Approx. 105 cc
Weight	Approx. 115 g

Feature

<< Display/Indication >>

- 24-Digits Capacity (for Dialing and Storage)
- 11-Characters × 2-Lines Large Display + Indicator
- Battery Indicator
- Receiving Signal Strength Indicator
- Own Telephone Number Display
- Out of Area Indicator
- Softkey Display
- 2-Line Operation (L1 & L2)

<< Memory >>

- Directory Dial (100 numbers with name)
- Speed Dial (20 numbers with name)
- Last Number Redial (10 numbers)
- Calling Party Number (10 numbers)
- Scrolling by Name on Memory Location

<< Calling >>

- Incoming Call Indicator
- DTMF Dialing
- Vibrator Alert
- Automatic Answer

<< General >>

- Back Lighting
- Low Battery Alarm
- Volume Control (ringing tone, earpiece)
- Voice Mail Indication (VMI)
- Lock Function
- Name Display

◆ Cell Station (CS)

Because of its small size, light weight and slenderness, the CS can be installed anywhere...the wall surface, the ceiling or behind the ceiling. In addition, its expansion or relocation can be smoothly performed.

Followings are the specifications for the CS.

Specification of Cell Station

Table 3-4 2-Wired (U-Interface) Cell Station (CS) Specifications

Item	Specifications
Radio Interface	RCR STD-28 Ver. 2 (RF Power : 10mW Average)
PBX Interface	2-Wire (metallic)
Maximum Simultaneous Access per CS	3 Personal Stations
Volume	Approx. 700 cc
Size	Approx. 141 (W) × 183 (D) × 36 (H) mm (Excluding Antenna)
Weight	Approx. 380 g
Power Supply	<ul style="list-style-type: none"> ▪ PBX Power Supply (DC-48V) ▪ Local Power Supply (AC 100V/200V)
Application	In Door Type

* This CS can download new soft program from MAT, so it can easily maintenance and operation.

◆ **IP Base Station (IP-BS)**

PHS Base Station is installed on the IP network and LAN, and Wireless Communication System can be built. Management such as wiring can be reduced by IP-ization.

Specification of IP Base Station

Table 3-5 IP Base Station (IP-BS) Specifications

Item	Specifications
Wire Interface	10M/100M RJ45 Connector 1port
Wireless Interface	RCR STD-28 3rd edition
Number of Simultaneous calls	3CH
Operating environment Power consumption	0-40 degree, 7W
Voice codec	G.711, G.729a, G.723.1
Dimensions	160 × 159 × 40mm (w/o an antenna)
Power Supply	Local power supply:AC-R UNIT Central power supply: Correspond to electric supply HUB <ul style="list-style-type: none"> ▪ SN8051 POESWEA-A(NEC) ▪ Catalyst 3550-24 PWR (Cisco) ▪ Catalyst Inline Power Patch Panel (Cisco)

* This IP-BS can download new soft program from MAT, so it can easily maintenance and operation.



2-Wired Cell Station (CS)
(U-Interface)



IP-BS
(TCP/IP or Ether)



Personal Station (PS)

Figure 3-14 Cell Station (CS), IP Base Station (IP-BS) and PHS Personal Station (PS)

Personal Communication System (PCS)

◆ **Personal Station (PS)**

The PS (Personal Station) incorporates the 32 Kbps ADPCM encoding technique and privacy function so that you can talk about even important matters in a noise-free, very clear voice.

Since the PS is light-weight and compact in size, it can conveniently be carried around.

Here are specifications for the PS and its major functions.

Specification of Personal Station

Table 3-6 PCS Personal Station (PS) Specifications

Item	Specifications
Frequency	1.920 ~ 1.930 GHz
RF Power	6.8 mW (Average)
Voice Coding/Decoding System	32 Kbps ADPCM
Basic Specifications	Compliance with TIA/EIA-667 PACS WUPE
Continuous Talk Time	Approx. 6 Hours
Continuous Standby Time	Approx. 500 Hours
Waterproof	Supported
Dimensions	Approx. 40 (W) × 24 (D) × 130 (H) mm (Excluding Antenna)
Volume	Approx. 105 cc
Weight	Approx. 115 g

Feature

<< Display/Indication >>

- 24-Digits Capacity (for Dialing and Storage)
- 11-Characters × 2-Lines Large Display + Indicator
- Battery Indicator
- Receiving Signal Strength Indicator
- Own Telephone Number Display
- Out of Area Indicator
- Voice mail indication
- Softkey Display
- 2-Line Operation (L1 & L2)

<< Memory >>

- Directory Dial (100 numbers with name)
- Speed Dial (20 numbers with name)
- Last Number Redial (5 numbers)
- Calling Party Number (5 numbers)
- Scrolling by Name on Memory Location

<< Calling >>

- Incoming Call Indicator
- DTMF Dialing
- Vibrator
- Alert
- Automatic Answer

<< General >>

- Back Lighting
- Low Battery Alarm
- Volume Control (ringing tone, earpiece)
- Lock Function
- Voice Mail Indication (VMI)
- Wireless roaming
- Name Display

◆ Zone Transceiver (ZT)

Because of its small size, light weight and slenderness, the ZT can be installed anywhere...the wall surface, the ceiling or behind the ceiling. In addition, its expansion or relocation can be smoothly performed.

Followings are the specifications for the ZT.

Specification of Zone Transceiver (ZT)

Table 3-7 Zone Transceiver (ZT) Specifications

Item	Specifications
	▪ 2 Wire Zone Tranceiver (U-I/F)
Radio Interface	TIA/EIA-667 PACS WUPE (RF Power : 6.8mW Average)
PBX Interface	2-Wire (metallic)
Maximum Simultaneous Access per ZT	3 Personal Stations
Volume	Approx. 560 cc
Size	Approx. 160 (W) × 139 (D) × 40 (H)mm (Excluding Antenna)
Weight	Approx. 400 g
Power Supply	<ul style="list-style-type: none"> ▪ PBX Power Supply (DC-48V) ▪ Local Power Supply (AC 100V/200V)
Application	In Door Type/Outdoor Box (Option)

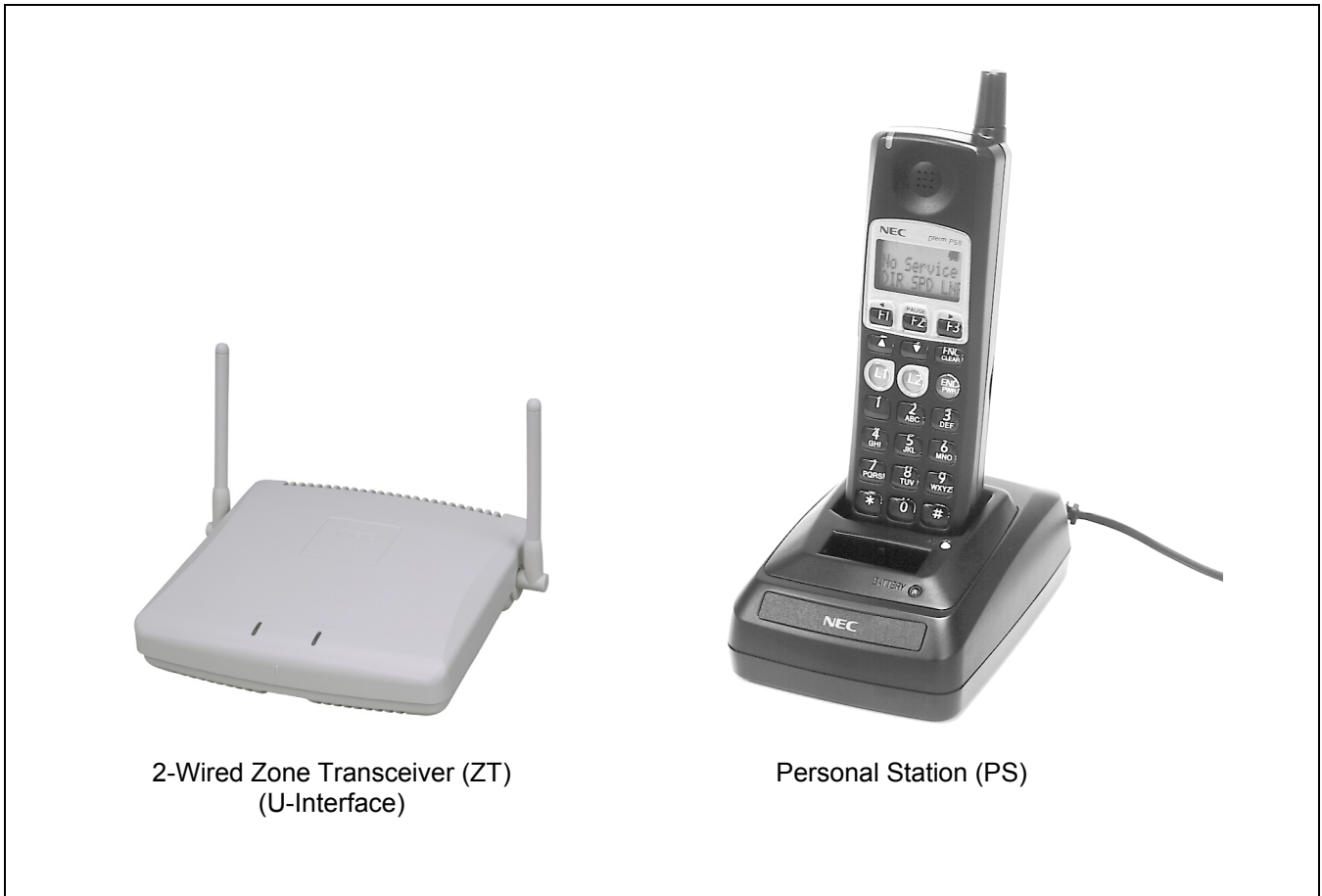

Figure 3-15 Zone Transceiver (ZT) and PCS Personal Station (PS)

D^{term} Softphone (SP30)

This D^{term} Softphone provides the IP-enabled D^{term} features without the telephone set, and it works on the Windows PC connected to LAN network. You click the button on the picture, the button, lamp and LCD works like an actual telephone. In addition to making and answering calls operation, D^{term} SP30 provides call logs for all incoming and outgoing calls the user has made or received, and a recording of live conversation.

D^{term} SP30 also provides telephone directory integration. Users can dial one of four ways:

- Manual entry
- Drag and Drop numbers displayed in the contact book within MS Outlook
- Copy and Paste numbers displayed in Excel and/or the contact book within MS Outlook
- Using any PC telephony directory which can be linked via the API (DDE) interface of the D^{term} SP30 Softphone

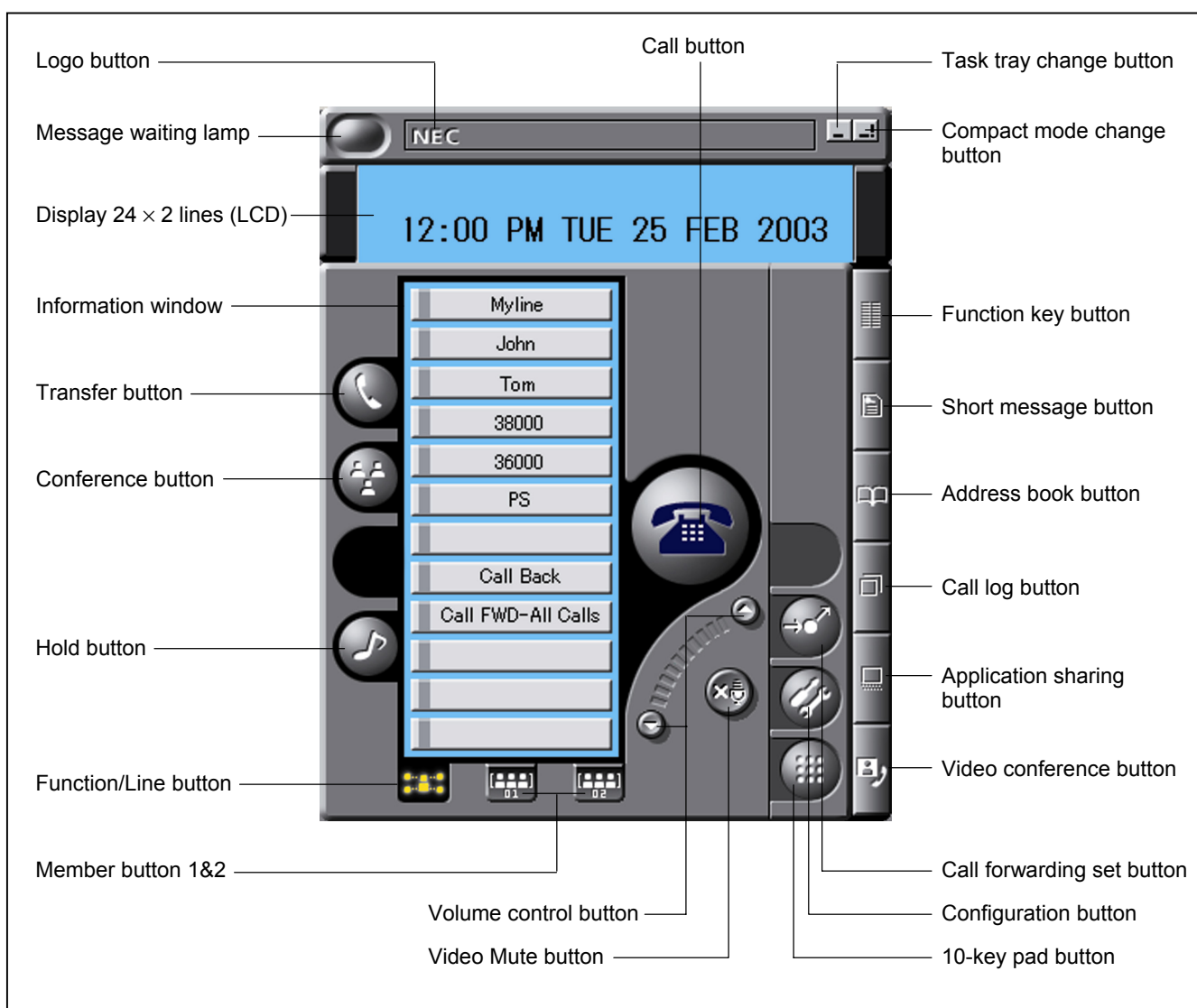

Figure 3-16 SP30 Screen

Subpanels and Functions

Function Key Panel

Displays lines and functions set for PBX and enables changing of button name and pop-up.

Short Message Log Panel

Displays transmission, reception and error logs of simple messages and lets user select a log to telephone or reply to a sender.

Call Forward Settings Panel

For setting or cancelling Call Forwarding-All Calls/Busy Line/ Don't Answer/ Log Out for PBX.

Call Log Panel

A user can see origination and termination types, times, telephone numbers, conversation times, and speech memos; then save them in CSV-format file. Select a log for origination/termination, speech memo input, or deletion.

Configuration Panel

For setting origination rules, termination actions, voices, video conference actions, simple message actions, the number of logs, user names, automatic log in, and other convenient functions.

Video Conference Panel

Using cameras in conjunction with this panel, you can see video of calling party in the upper panel and yourself in the lower panel.

Application Sharing Panel

For application sharing and white board functions.

10-Key Keypad Panel

Can be used like the dial pad of a telephone.



Video Conference Panel

Requirements

Operating Environment

PC	IBM/PC-AT compatible machine
OS	WindowsXP/2000
Memory	256MB or more
PCU	Pentium 800MHz or more
HDD	10MB or more in unused memory
Audio device	USB handset (optional)
PBX-compatible	NEAX 2400 IPX (FP8700-R14 or later) NEAX 2000 IPS (FP3300-R8 or later)

IP Relation

LAN interface	10M/100M Ethernet
Transport protocol	Voice RTP
	Signal UDP/TCP
Setting of IP address	DHCP setting/Direct setting
QoS	TOC, IP Precedence, Diffserve
Payload cycle	20ms/30ms/40ms
Voice encoding	G.711 (64k)

CHAPTER 4 OVERVIEW OF INSTALLATION, PROGRAMMING, AND MAINTENANCE

Installation

Items to be Provided at Site

The following items are required for correct operation.

- a.) Adequate space accommodation
- b.) Adequate ventilation
- c.) Commercial AC power

Grounding Requirements

The system grounding must have a specific ground resistance and AC noise level, and is to be connected to a predetermined terminal in the PBX. Standard grounding requirements are as shown below:

- Communication grounding : Less than 10 ohm
- Protective ground for PIM : Less than 10 ohm

Note: *The AC ripple on these various grounds should be less than 0.5Vp-p.*

CAUTION

Grounding circuit continuity is vital for safe operation of telecommunication equipment. Never operate this equipment with the grounding conductor disconnected.

The following specific requirements apply to ground wiring.

An equipment-grounding conductor that is at least as large as the ungrounded branch-supply conductors is to be installed as part of the circuit that supplies the PBX. Bare, covered, or insulated grounding conductors are acceptable. Individually covered or insulated equipment grounding conductors shall have a continuous outer finish that is either green, or green with one or more yellow stripes. The equipment grounding connector is to be connected to ground at the service equipment.

The attachment-plug receptacles in the vicinity of the PBX are all to be of a grounding type, and the equipment grounding conductors serving these receptacles are to be connected to earth ground at the service equipment.

Installation of Main Equipment

The installation of the NEAX 2000 IPS is comprised of up to 8 Port Interface Modules (PIMs). A PIM provides 13 card slot for Common Control, Line/Trunk (LT), and Application Processors (AP) cards. It also houses an AC/DC Power Supply, DC/DC Power Supply (for -48V), and batteries for protection from short-term (about 30 minutes) power interruption.

Cabling inside the unit, between the switching equipment and the MDF, can all be done by plug-and-jack connections, while printed circuit cards can easily be plugged into the edge connectors. On all installations, a special provision for plug-and-jack connections completely eliminates possible errors in wiring. This allows the installation to be done easily and smoothly.

Mounting Circuit Cards

- (1) Before mounting the circuit cards, confirm the following items.
 - Wrist Strap is connected to Frame Ground.
 - Switch settings of circuit cards are already completed.
 - The “SW1” switches of all PZ-PW121/PZ-PW126 cards are turned off.
- (2) Mount circuit cards into their mounting positions according to the “Bay Face Layout” and “Port Assignment Table” given in the Office Data Programming Manual.

Various installation Methods

To meet the specific needs of the customer's environment, NEAX 2000 IPS provides the following installation methods:

Floor Standing Installation
Wall-mounting Installation
IEC standard 19-inch Rack-mounting Installation

Programming

System Initialization

There are two methods for System Initialization. The first method is to clear All Data, except LEN000 as a CAT terminal, then program the System Data. The second method is to use the Resident System Program, which causes the system to configure itself automatically to the default settings, wherever the line/trunk cards are installed.

System Data Entry

There are two methods for data entry, using a Customer Administration Terminal (CAT) or a Maintenance Administration Terminal (MAT).

CAT

Any D^{term} can be assigned as a CAT through programming. The D^{term} can still be used as a regular telephone when it is not in CAT mode.

MAT

The Maintenance Administration Terminal (MAT) is a personal computer that connects to the PBX using MATWorX software. MATWorX is a Windows-based software application that lets you program and configure any NEAX PBX from your computer. It is a framework or platform wherein PBX maintenance software (add-ins) resides. Its graphical user interface (GUI) makes it easier for you to manage and configure your PBX's features.

Maintenance

Trouble Reporting and Diagnosis

The urgency of a fault is indicated by the MJ/MN lamp provided on the Power Card and optional external alarm indicator.

System Administration

System data, which varies from installation to installation and which is subject to continual change during service, is readily entered or changed from the D^{term} or MAT (Maintenance Administration Terminal). The system data can be downloaded to, or uploaded from, a floppy disk in the MAT computer.

Remote Maintenance

Access to the NEAX 2000 IPS, for the purpose of system diagnosis, status reporting, and database reconfiguration, can be performed from remote locations (e.g., Maintenance Centers, Technical Assistance Service Centers, etc.). By taking advantage of the built-in modem on the NEAX 2000 IPS CPU, the following maintenance administration functions can be accomplished by a remotely located MAT via a modem over a central office network or a tie line network.

- System Data Correction/Upload/Download
- MP/FP Software Upgrade
- Control of Battery Disconnection
- Display of Line/Trunk Connections
- Detection of open or short circuit in the line cables for both analog and D^{term} telephones
- Fault Message Display

CHAPTER 5 SPECIFICATIONS

System Capacity

The following table shows the system capacity.

Table 5-1 System Capacity (Single MP System)

Item		System Capacity Note 1, 2							
		1PIM	2PIM	3PIM	4PIM	5PIM	6PIM	7PIM	8PIM
LT Card	(No. of Ports)	64	128	192	256	320	384	448	512
	(No. of Cards)	12	24	36	48	60	72	84	96
AP Card	(No. of Ports)	Max. 256 ports per system							
	(No. of Cards)	12	24						
Total Number of Lines (Analog Single Line Tel. + D ^{term})		64	128	192	256	320	384	448	512
IP PAD Note 3 (No. of Channel)		64		128		192		256	
Analog Single Line Telephone (Lines)	Standard	64	128	192	256	320	384	448	512
	Long Note 4	44	92	140	188	236	284	332	380
D ^{term}	Standard	64	128	192	256	320	384	448	512
	Long	22	46	70	94	118	142	166	190
D ^{term} IP/ D ^{term} IP INASET/ D ^{term} SP20/ D ^{term} SP30 (Peer-to-Peer Connection)		448	384	320	256	192	128	64	0
D ^{term} PS (Asia) / D ^{term} PS (LA) Note 5		256							
Cell Station (CS) / Zone Transceiver (ZT) Note 6		16	32	48	64	80	96	112	128
IP-BS (PHS) Note 6		112 Note 7							
ISDN Station		16	32	48	64	80	96	112	128
Central Office Trunk (Lines)	Loop Start	64	128	192	256	256	256	256	256
	DID w/4DIT	48	96	144	192	240	256	256	256
Tie Line Trunk (Lines)	4LDT	48	96	144	192	240	256	256	256
	2W E&M	24	48	72	96	120	144	168	192
	4W E&M	24	48	72	96	140	144	168	192
CCIS Trunk (Peer-to-Peer Connection)		Max. 127							
DTI/CCIS Digital Link Note 1	1.5M-AMI	DTI : 10, CCIS : 8							
	2M-AMI	Max. 8 Links per system							
ISDN	1.5M/2M-AMI (PRT)	8							
	2BRT (card)	12	24						
	4BRT (card)	6	12	18	24	24	24	24	24
IP Trunk Note 7		1	2	3	4	5	6	7	8
PFT Connections	8PFT	8	16	24	32	40	48	56	64
3-Party Conference		Max. 16 conference groups per system							
6-/10-Party Conference	6-Party	Max. 4 conference groups per system							
	10-Party	Max. 2 conference groups per system							
32-Party Conference		Max. 8 conference groups per system							
M13 (Splitter Card for HomePNA / VDSL DPC)		PIM 0: Max. 11, PIM 1-7: Max. 12 cards per PIM							
In-skin Router		Max. 8 cards per PIM							
DTMF Sender		Max. 32 circuits per system							
DTMF Receiver		16		32					
SN716 Desk Console		8							

Table 5-1 System Capacity (Single MP System) (Cont'd)

Item	System Capacity							
	1PIM	2PIM	3PIM	4PIM	5PIM	6PIM	7PIM	8PIM
Attendant Terminal (D ^{term} ATT Position)	Max. 8 sets per system							
SMDR Interface	Max. 1 interface port per system							
PMS Interface	Max. 1 interface port per system							
ACD / MIS or OAI Interface Note 8	Max. 1 interface port per system							
Remote PIM over IP (Number of PIM at Remote Site)	20 (depending on network configurations)							
DID Dial Conversion	1000							
Call Forwarding-Outside Set	496							
Authorization. Code / Forced Account Code / Remote Access to System (DISA) Code	3000							
Message Remainder Set	1024							
Name Display / Guest Name Display	512							
Speed Calling-Station (Station Speed Dial) Set	10000							
MP built-in SMDR Call Record	1280							

Note 1: *The total number of trunk line and DTI channel shall be 256 or less.
(Each trunk line and DTI channel are required to assign the “Trunk Number” by system data programming and maximum number of system parameter for “Trunk Number” is 256.)*

Note 2: *“PIM” in this table means “Physical PIM.”*

Note 3: *Maximum number of voice channels per IP PAD card depends on the payload size as follows.*

32IPLA+16VCTA

Payload Size	Maximum Voice Channels per IP PAD (32IPLA+16VCTA)		
	G.711	G.729a	G.723.1
10ms	12	12	-
20ms	20	20	-
30ms	30	30	24
40ms	32	32	-

8IPLA+24IPLA

Payload Size	Maximum Voice Channels per IP PAD (8IPLA+24IPLA)		
	G.711	G.729a	G.723.1
10ms	20	20	-
20ms	32	32	-
30ms	32	32	24
40ms	32	32	-

Table 5-1 System Capacity (Single MP System) (Cont'd)

Note 4: *Message Waiting Lamp is not available when the 4LLC is mounted in slot 08 to 10.*

Note 5: *From FP 3300, maximum 256 PS can be accommodated to the system in addition to the maximum 512 LT ports.*

*Ex: 400 Dterms + 100 CO Lines = 500 LT Ports
150 PSs } Total 650 Ports available*

Note 6: *Total number of CS and IP-BS should be 128 or less.*

Note 7: *Maximum voice channels per IP trunk card depends on the payload size as follows (payload size can be assigned by system data programming):*

▪ *CCIS (p-p/p-mp) and Peer-to-Peer*

Payload Size	G.729a	G.711	G.723.1
10 ms	4 Channel	4 Channel	-----
20 ms	8 Channel	8 Channel	-----
30 ms	16 Channel	16 Channel	16 Channel
40 ms	16 Channel	16 Channel	-----

▪ *VoIP (H.323)*

Payload Size	G.729a	G.711	G.723.1
20 ms	6 Channel	5 Channel	---
30 ms	8 Channel	7 Channel	8 Channel
40 ms	12 Channel	10 Channel	---

Note 8: *It is possible to connect 4 applications at the same time.*

IP Specifications

Table 5-2 IP Specifications

ITEM		SPECIFICATIONS	REMARKS
Voice Encoding		G.729a G.723.1 (5.3 k/6.3 k) G.711	8 kbps CS-ACELP MP-MLQ/ACELP 64 Kbps PCM
IP PAD		8/32 channels per card Automatically seized per call	
FAX Communication Feature		FAX Relay Method (T.30)	G3 FAX (up to 14.4 Kbps) Super G3 Reciprocal: Not allowed FAX communication with H.323: Not available PN-32IPLA/PN-32IPLA-A (IP PAD) card (PN-8IPLA (IP PAD) card is not available.)
		FAX Relay Method (Path-through (G.711/G.726))	PN-8IPLA (IP PAD) card (PN-32IPLA/PN-32IPLA-A (IP PAD) card is not available.)
DTMF Signal		H.245	H.323 IPT/IP PAD/D ^{term} IP
Inter-office/Intra-office Signaling		H.245	D ^{term} IP-to-D ^{term} IP connection D ^{term} IP-to-IP PAD connection
		PROTIMS over IP	D ^{term} IP-to-2000 IPS connection
		CCIS over IP	Point-to-Multipoint connection
		H.323	H.323 IPT/4VCT card and IP PAD card are required
Jitter Control		Dynamic Jitter Buffer	
Quality of Service (QoS)		<ul style="list-style-type: none"> ▪ TOS, IP Precedence ▪ DiffServ 	
LAN Interface		10BASE-T/100BASE-TX	Auto Negotiation is available. 100BASE-TX is recommended.
Echo Canceller (IP PAD)		G.168 (64 ms)	
Payload Size	D ^{term} IP/ CCIS Virtual IPT (32IPLA + 16VCT)	10 ms. -40 ms. (G.723.1: 30 ms. fixed) Note	Max. voice channels per card <u>G.729a</u> <u>G.711</u> <u>G.723.1</u> 10 ms: 12 ch 12 ch - 20 ms: 20 ch 20 ch - 30 ms: 30 ch 30 ch 24 ch 40 ms: 32 ch 32 ch -
	D ^{term} IP/ CCIS Virtual IPT (8IPLA + 24IPLA)	10 ms. -40 ms. (G.723.1: 30 ms. fixed)	Max. voice channels per card <u>G.729a</u> <u>G.711</u> <u>G.723.1</u> 10 ms: 20 ch 20 ch - 20 ms: 32 ch 32 ch - 30 ms: 32 ch 32 ch 24 ch 40 ms: 32 ch 32 ch -
	H.323 IPT	20 ms.-40 ms. (10 ms. increments) (G.723.1: 30 ms. fixed)	Max. voice channels per card <u>G.729a</u> <u>G.711</u> <u>G.723.1</u> 20 ms: 6 ch 5 ch - 30 ms: 8 ch 7 ch 8 ch 40 ms: 12 ch 10 ch -

Table 5-2 IP Specifications (Cont'd)

ITEM	SPECIFICATIONS	REMARKS
PAD Control	0 dB to +16 dB (+2 dB increments) 0 dB to -16 dB (-2 dB increments) When using PN-8IPLA (IP PAD): 0 dB to +14dB (+2 dB increments) 0 dB to -14 dB (-2 dB increments)	Setting is available per Location No. For connection between D ^{term} IPs
	0 dB to -16 dB (For North America) 0 dB to -12 dB (For other than North America)	For connection via the IPT card

Note: *When no 16VCT card is mounted, the CODEC type is fixed to G.711 and the payload size is fixed to 40 ms.*

Line Conditions

Table 5-3 Line Conditions

Loop Resistance Note 1					
Analog Telephone Set	Standard		600 ohms		
	Option		2,500 ohms (DP: 10pps), 1,700 ohms (DP: 20pps), 1,200 ohms (DTMF)		
Loop Start Trunk	Exchange Line		1,700 ohms		
	Tie or DID Line		2,500 ohms		
Cable Length Note 2			Standard	with AC Adapter	
Dterm Series i	D ^{term} 2/8/8D/16D	8DLC	300m (984ft)	Note 3	
		4DLC	300m (984ft)	1200m (3937ft)	
		2DLC	850m (2789ft)	1200m (3937ft)	
	D ^{term} 32D D ^{term} 16LD	8DLC	200m (656ft)	Note 3	
		4DLC	200m (656ft)	1200m (3937ft)	
		2DLC	850m (2789ft)	1200m (3937ft)	
	DSS/BLF Console Note 4	8DLC	-	300m (984ft)	
		4DLC	-	1200m (3937ft)	
		2DLC	-	1200m (3937ft)	
	Operation Position	Attendant Terminal		Same as D ^{term} Series i	
		SN716 Desk Console	8DLC and PN-PW00 or AC Adapter		300m (984ft)
			4DLC and PN-PW00		350m (1148ft)
4DLC and AC Adapter			1200m (3937ft)		
2DLC			350m (1148ft)		

Note 1: Loop resistance includes an internal resistance of telephone set or distant exchange.

Note 2: Cable length is based on the following conditions.

- Diameter of the cable is 0.5 mm.
- The Protection arrester is not inserted between the terminal and PBX.

Note 3: When using 8DLC card, it is not available for long line function, even if it is equipped with AC Adapter.

Note 4: The DSS/BLF Console requires local AC/DC supply.

Cell Station/Zone Transceiver Line Conditions

Table 5-4 Cell Station/Zone Transceiver Line Conditions

▪ DESCRIPTION	▪ SPECIFICATIONS
Cell Station	
BS21A (for S-Interface)	Max. 900 meters @-43V
BS21A with AC Adapter	Max. 960 meters @-43V
BS31 (for U-Interface)	Max. 800 meters (2-wire), Max. 1,600 meters (4-wire) @-43V Note
BS31 with AC Adapter	Max. 5,000 meters
Zone Transceiver (for Latin America)	
ZTII-S (for S-Interface)	Max. 1,219 meters @-48V, Max. 975 meters @-45V
ZTII-S with AC Adapter	Max. 1,341 meters @-48V
ZTII-U (for U-Interface)	Max. 1,219 meters (2-wire), Max. 2,103 meters (4-wire) @-48V Note
	Max. 975 meters (2-wire), Max. 1,706 meters (4-wire) @-45V
ZTII-U with AC Adapter	Max. 3,958 meters

Note: Cable length is based on cable with 0.5 mm diameter and without lightning arresters.

Traffic Capacity

Table 5-5 Traffic Capacity

Number of PIMs	1PIM	2PIM	3PIM	4PIM	5PIM	6PIM	7PIM	8PIM
Traffic Capacity	Max. 2500 BHCA		Max. 5000 BHCA Note		Max. 7500 BHCA Note		Max. 8000 BHCA Note	

Note: The traffic load of each FP shall be 2500 BHCA or less.

DRS (Device Registration Server)

Table 5-6 DRS (Device Registration Server)-System Based

Features of Built-in DRS		Description	Remarks
Max Registration Terminal		512/MP	
Log-in	Login without password	Not Available	Use blank as a password
	Authentication by DRS-Network Based	Not Available	
	Authentication by DRS-System Based	Available	
	Authentication by MAC Address	Available	
	Confirmation when overriding	Available	
Log-out	Dialing Log-out feature access code	Available	
	Function key	Available	
	Soft key	Available	
DHCP	Inter-working with DHCP server	Available	

Free Manuals Download Website

<http://myh66.com>

<http://usermanuals.us>

<http://www.somanuals.com>

<http://www.4manuals.cc>

<http://www.manual-lib.com>

<http://www.404manual.com>

<http://www.luxmanual.com>

<http://aubethermostatmanual.com>

Golf course search by state

<http://golfingnear.com>

Email search by domain

<http://emailbydomain.com>

Auto manuals search

<http://auto.somanuals.com>

TV manuals search

<http://tv.somanuals.com>