

UNIMUX™ Series

UNIMUX-USBV-xHD

High Density VGA USB KVM Switch Installation and Operation Manual



TRADEMARK

UNIMUX is a trademark of Network Technologies Inc in the U.S. and other countries.

COPYRIGHT

Copyright © 2000, 2008 by Network Technologies Inc. All rights reserved. No part of this publication may be reproduced, stored in a retrieval system, or transmitted, in any form or by any means, electronic, mechanical, photocopying, recording, or otherwise, without the prior written consent of Network Technologies Inc, 1275 Danner Drive, Aurora, Ohio 44202.

CHANGES

The material in this guide is for information only and is subject to change without notice. Network Technologies Inc reserves the right to make changes in the product design without reservation and without notification to its users.

FIRMWARE VERSION

Main Controller Firmware Version 1.1

Typographic Conventions

Typeface meaning	Font Configuration	Example
On-screen computer output	Courier New-(not bold)	C:>
What you type on the computer	Courier New-bold	C:>edit text.bat
Keyboard Keys to be pressed as instructed in the body of a paragraph	Courier New-bold Surrounded by < >	"<L>" means press the "L"

General

Character	Meaning	Example
+	When "+" is shown between keystrokes, it indicates a chorded sequence (press and hold the keys consecutively until all keys in the sequence are pressed)	<Ctrl>+<`> (accent/tilde key) is a chorded sequence to enter Command Mode.
-	When "-" is shown between keystrokes, it indicates to press the keys consecutively (press and release one at a time)	<A>-<S>-<S>-<E> is a sequence of keys pressed to enable Security Mode

TABLE OF CONTENTS

INTRODUCTION	1
MATERIALS	2
Materials Supplied:	2
Materials <i>Not</i> Supplied, but <i>REQUIRED</i>	2
FEATURES AND FUNCTIONS.....	3
Additional Features.....	4
RACK MOUNTING INSTRUCTIONS.....	5
To Mount to a Rack	5
INSTALLATION	6
RS232 Connection.....	9
Limitations.....	10
USING THE UNIMUX USB KVM SWITCH	11
Basic Operation	11
Front Panel Control.....	11
Keyboard Control.....	11
OSD CONTROL	12
Guidelines for Navigating OSD Menus.....	12
Security Option	12
Initial startup	13
User Access Functions	13
Command Mode	13
Settings	15
OSD Settings	16
Find Mode	16
Help Mode.....	17
Scan Mode.....	17
Broadcast Mode.....	18
Normal Mode	18
F3- Display Information.....	19
Security	20
Enabling Security.....	20
Password and User Name.....	20
User Login.....	21
Additional OSD Modes Available With Security Enabled	21
Administration Menu	21
System Configuration	22
Port Configuration	22
User Configuration	23
Edit User Account	23
User Access Control	24
Change Administrator Password	24
Display Usage.....	25
Idle Timeout.....	25
OSD Blank Timeout	25

Alternate Command Hot Key	26
Reset Port names	26
Select Keyboard Language	26
Security Configuration	27
Serial Baud Rate.....	28
Serial Address.....	28
Keyboard Mapping.....	29
Key Equivalents	29
Mouse Click Equivalents.....	29
SUN's 16 Extra Keys	29
RS232 CONTROL.....	31
Remote Connection	31
Baud Rate.....	31
Unit Address and Loop Back	31
RS232 Command Protocol.....	33
RS232 Command Protocol Quick Reference	33
Autostatus.....	34
NTI Switch Control Program For Windows 9X, NT, 2000, XP and Vista	34
SerTest- RS232 Interface Test Program	35
Main Options.....	35
Matrix Operations.....	35
Setup Options	35
RMTEST-RS232 Interface Test Program.....	36
CASCADING	37
Limitations.....	37
Cable Connections	37
Operating Cascaded Switches	38
SUN RAY SUPPORT	39
FIRMWARE UPGRADE PROCEDURE.....	40
Requirements	40
PREPARATION FOR UPGRADE	41
UPGRADE PROCEDURES.....	42
Start the Bootloader.....	42
Update the User Controller Firmware.....	43
Update the HID Port Controller Firmware.....	43
Update the Vendor Specific Port Controller Firmware.....	44
Read the Checksum of HID or Vendor Specific Port Controller Firmware.....	45
SAFETY STATEMENTS	46
CABLES	46
TROUBLESHOOTING	47
SPECIFICATIONS	47
INDEX.....	48
WARRANTY INFORMATION.....	48

TABLE OF FIGURES

Figure 1- Secure rackmount ears to switch.....	5
Figure 2- Secure switch to a rack	5
Figure 3- Install user monitor	6
Figure 4- Install user touch screen monitor.....	6
Figure 5- Install user devices (mouse and keyboard)	7
Figure 6- Use USB-A+A-5M to extend a device, or a computer.....	7
Figure 7- Connect each CPU using a HDUSBVEXT-xx-MM cable	8
Figure 8- Connect cable for RS232 control.....	9
Figure 9- Compatible device combinations	10
Figure 10- Command Mode main menu-User.....	14
Figure 11- Administrator's main menu	15
Figure 12- Settings menu.....	15
Figure 13- OSD Settings screen	16
Figure 14- Find Mode in use	16
Figure 15- Main Menu help screen	17
Figure 16- Scan List.....	17
Figure 17- Broadcast List.....	18
Figure 18- Port information- system structure.....	19
Figure 19- User login screen.....	20
Figure 20- Administrator's main menu	20
Figure 21- User Login screen with	21
Figure 22- Administration Mode Menu	21
Figure 23- System Configuration menu	22
Figure 24- Port Configuration menu.....	22
Figure 25- User Configuration.....	23
Figure 26- User Account menu	23
Figure 27- Access Control list	24
Figure 28- Administrator password menu	24
Figure 29- Usage Statistics Page	25
Figure 30- Change value of Idle Timeout.....	25
Figure 31- Change the value of OSD Blank Timeout.....	25
Figure 32- Alternate Command Hot Key selection window	26
Figure 33- Select Language menu.....	26
Figure 34- Security Configuration	27
Figure 35- Login screen with security disabled	27
Figure 36- Adjust Baud Rate.....	28
Figure 37- Adjust Serial Address	28
Figure 38- Keyboard layouts.....	30
Figure 39- RS232 connection with Matrix-Y-1 cable.....	32
Figure 40- Pinout of Matrix-Y-1 cable	32
Figure 41- Cascading with only single-user units.....	37
Figure 42- Cascaded connections with multi-user slaves	38
Figure 43- Preparation for firmware upgrade	41

INTRODUCTION

The UNIMUX-USBV-xHDU High Density VGA USB KVM switch (UNIMUX) allows access to any Windows, MAC, or SUN USB CPUs from one monitor, USB keyboard and USB mouse (up to 32 CPUs as a single switch or 512 CPUs when cascaded). Internal microprocessor circuitry allows all USB CPUs to be booted simultaneously without keyboard error. Port selection is accomplished by front panel push buttons or commands typed on the keyboard. Port lights and status LEDs continuously update on the front panel. Video formats up to 2048X1536 at 150MHz bandwidth can be displayed from all platforms.

Types of User Input Devices Supported:

- Most USB Keyboards and Mice, corded and wireless

Types of CPUs Supported:

Any USB CPU supporting USB version 1.0 or above including:

- USB Windows (all)
- USB MAC
- USB SUN
- Linux

Other Devices Supported:

- Touch screen monitors
- Smart boards
- CAC Card readers

Note: *These devices are not supported when the UNIMUX is cascaded.*

Option:

Extra USB device port for connection of USB cable from touch screen monitor or CAC card reader- add a "U" to the part number (i.e. UNIMUX-USBV-xHDU)

MATERIALS

Materials Supplied:

- NTI UNIMUX-USBV-xHD High Density USB KVM Switch
- IEC Power cord- country specific
- Rackmount kit (4, 8, and 16 port models only)
- CD with pdf file of this manual and RS232 control software
- DB9 Female-to-RJ45 Female adapter
- DB25 Female-to-RJ45 Female adapter
- 5 foot RJ45-to-RJ45 CAT5 patch cable

Materials Not Supplied, but REQUIRED

- HDUSBVEXT-xx-MM cable for each CPU being connected to the switch

Where:

xx is the length of the cable in feet (3,6,10, or 15 feet available)

MM indicates male-to-male connector

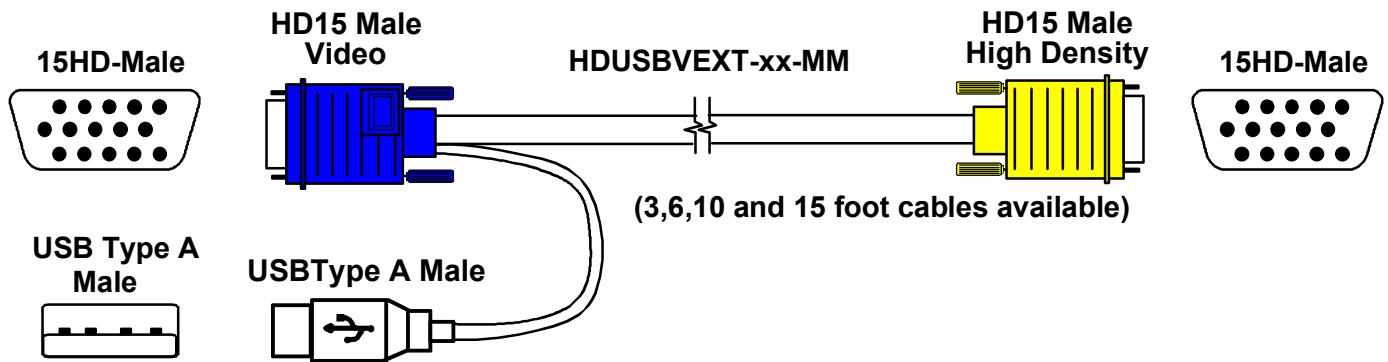

Cables can be purchased from Network Technologies Inc by calling 800-RGB-TECH (800-742-8324) or 330-562-7070 or by visiting our website at www.networktechinc.com.

See page 46 for some of the available cables.

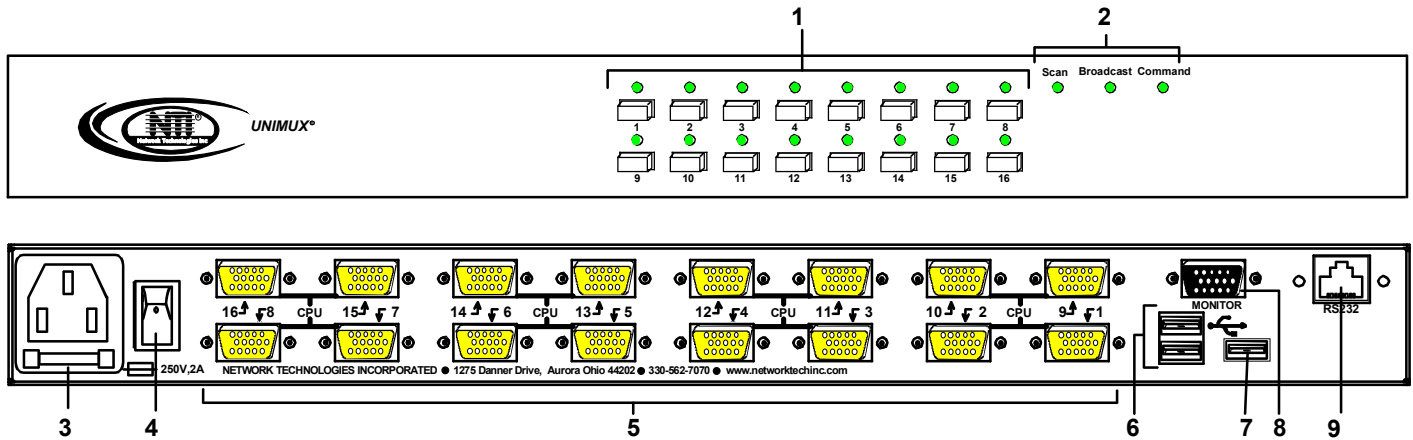

FEATURES AND FUNCTIONS

1. **CPU Select Switches**- push to manually switch to a specific CPU or change the switch operating mode
2. **Mode Status LEDs**- for visual indication of switch operating mode
3. **IEC Power Connector**- for attachment of power cord
4. **Power switch**- for turning the power to the UNIMUX On/Off
5. **CPU x**- 15HD yellow female high-density connectors- for connection of CPU cables for video and device support
6. **USB User Device**- USB Type A female connectors- for connection of user device cables;
7. **USB User Device**- for USB cable from touch screen monitor or CAC card reader (UNIMUX-USBV-xHDU models only)
8. **MONITOR x**- 15HD female connectors- for connection of user monitors
9. **RS232**- RJ45 female- for attaching RS232 interface cable from a CPU to control the functions of one or more switches

Additional Features

- Any USB type user device can control any USB CPU (Windows, MAC, and SUN platforms).
- Power cycle circuit control allows the UNIMUX switch to be powered OFF, then ON, at any time without affecting the attached CPUs. (This assumes that the CPU supports hot plugging.)
- Security features can be enabled.
- A microprocessor is dedicated to each CPU, preventing connected CPUs from locking up.
- Any user device cable can be hot-plugged.
- The front panel LEDs indicate the CPU the user is connected to.
- No dip-switches or jumpers necessary to configure.
- Video formats up to 2048X1536 can be displayed from all platforms.
- Users can control the switch using the On Screen Display (OSD)
- RS232 control allows control of the switch with one CPU serial port. (Windows-based software is provided.)
- NTI Switch Control Program provides easy and powerful graphical control of NTI switches through the RS232 interface. (Windows only.)

RACK MOUNTING INSTRUCTIONS

This NTI switch was designed to be mounted to a rack or to sit on a desktop. It includes rackmount ears to make attachment to a rack easy, and rubber feet to be applied to the bottom of the case if it will instead sit on a flat surface. If this will sit on a flat surface, simply apply the rubber feet to the bottom of the case in each of the 4 corners.

To Mount to a Rack

1. Attach the ears to the switch using the 6-32x3/16" flat Phillips-head screws (6) provided as shown in the illustration below. The holes in the ears should line up with pre-threaded holes in the sides of the NTI switch. Tighten the screws securely.

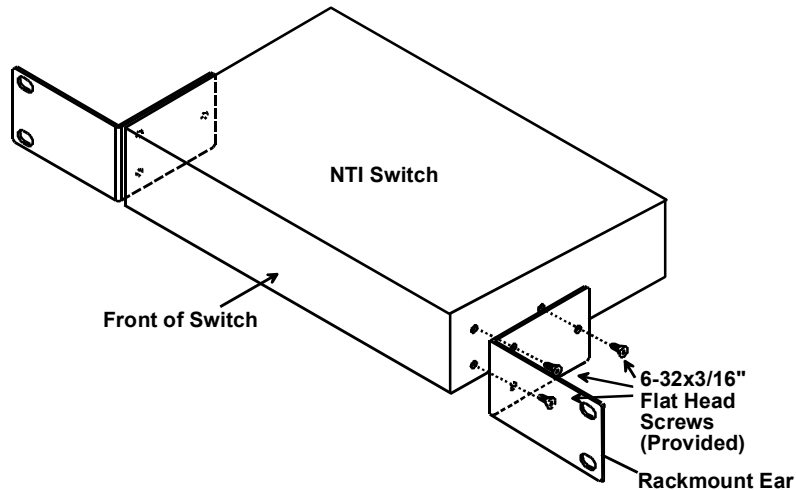

Figure 1- Secure rackmount ears to switch

2. Install 4 captive nuts (not provided) to the rack in locations that line up with the holes in the mounting ear on the NTI switch.
3. Secure the NTI switch to the rack using four 3/16" diameter screws (not provided). Each screw should be of sufficient length to go completely through the NTI mounting ear, rack frame and fully engage all threads in the captive nut. Be sure to tighten all mounting screws securely.
4. Attach all cables securely to the switch and where necessary supply adequate means of strain relief for cables.

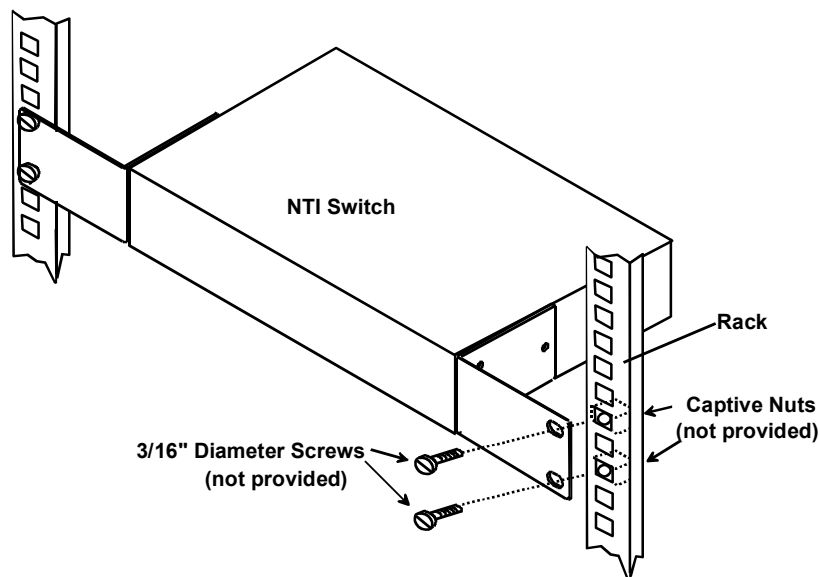

Figure 2- Secure switch to a rack

INSTALLATION

It is not necessary to turn OFF power to CPUs or monitors during this installation unless RS232 is going to be connected. All cables, except for the RS232 cables, may be hot plugged.

If using RS232 Control see RS232 section on page 31 for more information. Observe normal precautions when connecting the RS232 cables to the CPU. Refer to the owner's manual for the CPU being connected for precautions, if any.

1. Connect the 15HD male cable end from the user monitor to the female black 15HD port marked "MONITOR x" on the rear of the UNIMUX switch (see Figure 3). If a touch screen monitor is being connected (models with touch screen support only), connect the USB cable from the monitor to any one of the USB type A connectors in the same user device port group (see Figure 4).

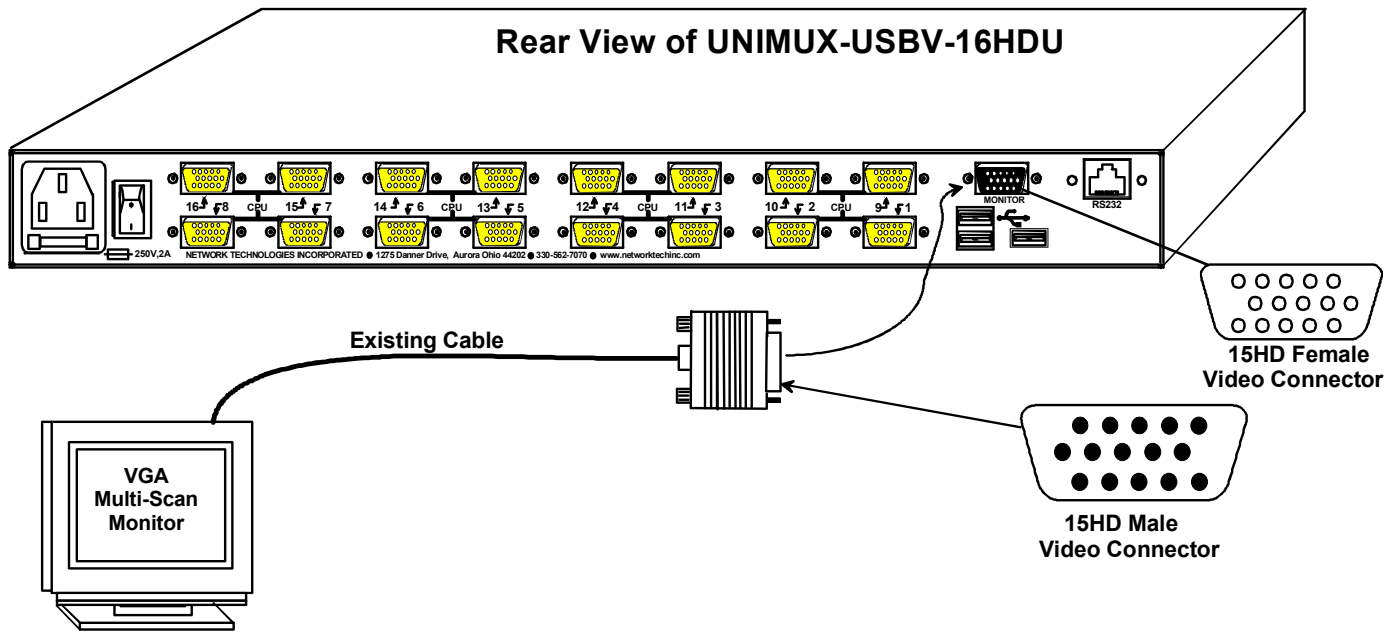

Figure 3- Install user monitor

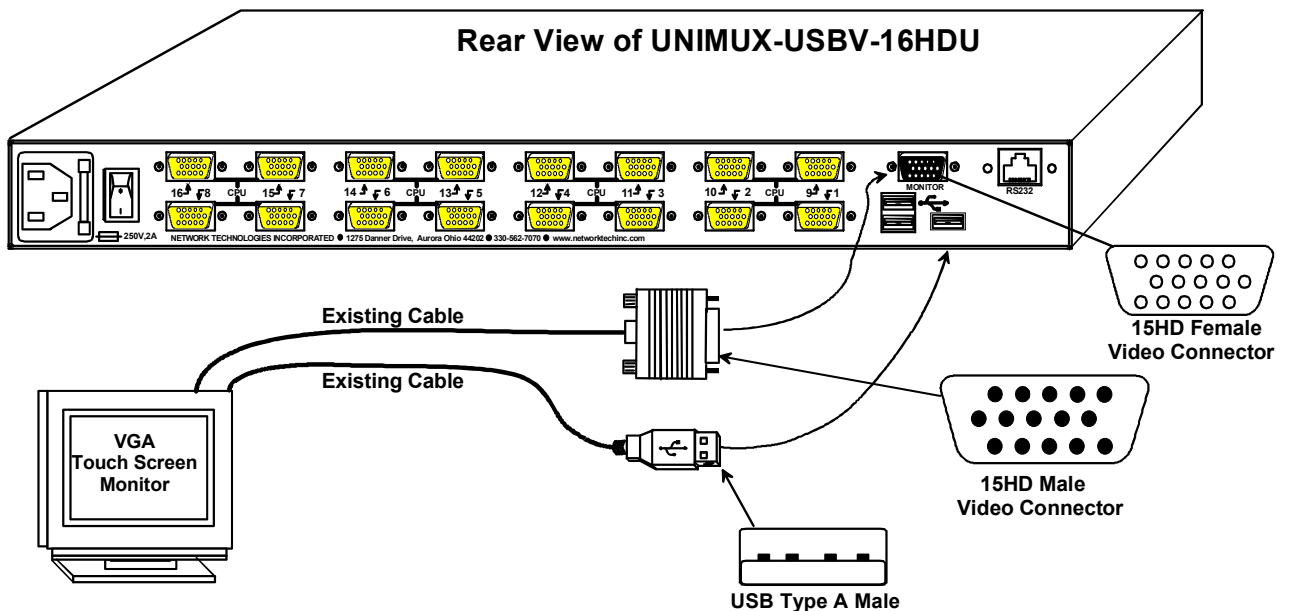



Figure 4- Install user touch screen monitor

- Connect the user devices to the USB type A female ports labeled with the USB symbol () on the rear of the UNIMUX switch (see Figure 5).

Note: If there are three (3) USB type A female ports present (models with CAC card reader or touch screen support only), then the third USB port is available for connection of a USB cable from a touch screen type monitor or CAC card reader. The USB ports are not device specific, so the mouse, keyboard, and touchscreen monitor or CAC card reader cable can be connected to any of the available USB ports present.

Note: If device cables are not long enough to reach the UNIMUX switch, they can be extended either 5 or 10 meters using either 1 or 2 NTI USB-A+A-5M Improved Active USB 5 Meter Extensions (see Figure 6)- purchased separately. Contact your NTI salesperson for more details by calling (800) 742-8324 (800-RGB-TECH) or (330) 562-7070 or visit our website at <http://www.networktechinc.com>.

Note: Only one non-HID (Human Interface Device) can be connected to the UNIMUX at a time. (i.e. if a CAC card reader is present, then a touch screen monitor cannot be used)

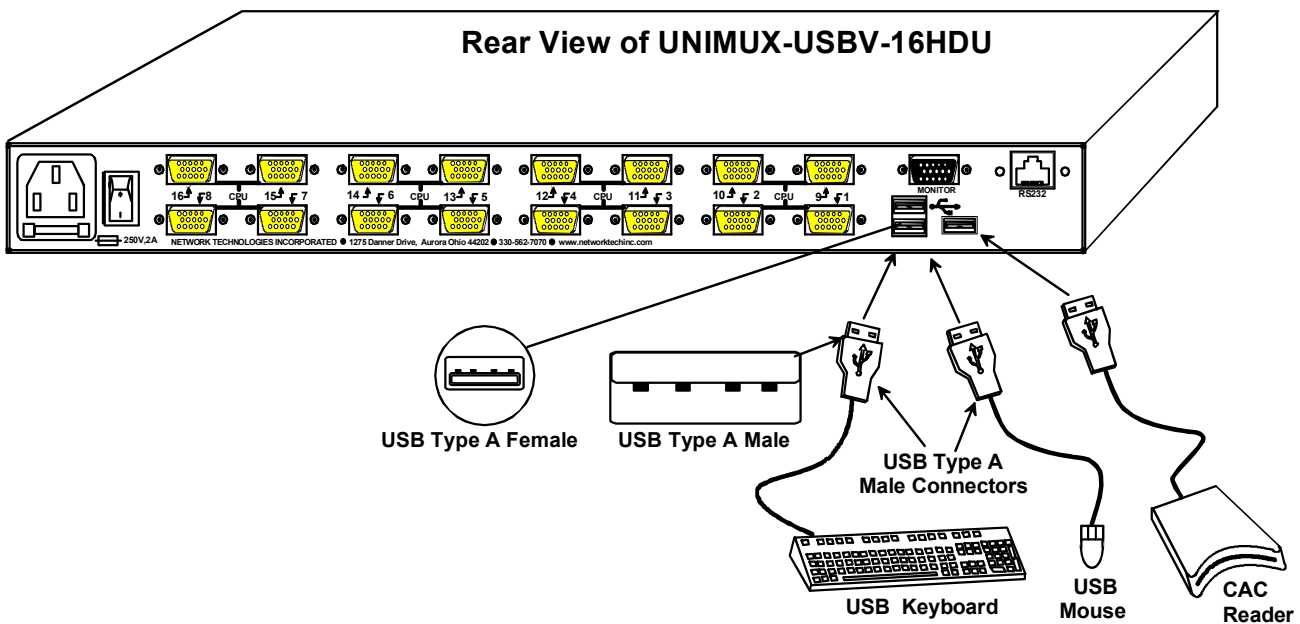

Figure 5- Install user devices (mouse and keyboard)

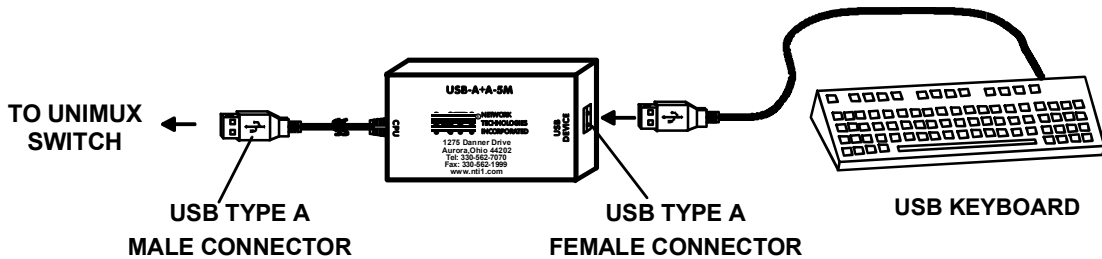

Figure 6- Use USB-A+A-5M to extend a device, or a computer

3. For each CPU:

- Connect a USB type A cable end of a HDUSBVEXT-xx-MM cable to a USB type A female user device port on a CPU.
- Connect the 15HD blue male cable end of a HDUSBVEXT-xx-MM cable to the video port of the same CPU.
- Connect the 15HD yellow male cable end of the HDUSBVEXT-xx-MM cable to a yellow “CPU x” port on the UNIMUX switch. (See Figure 7)

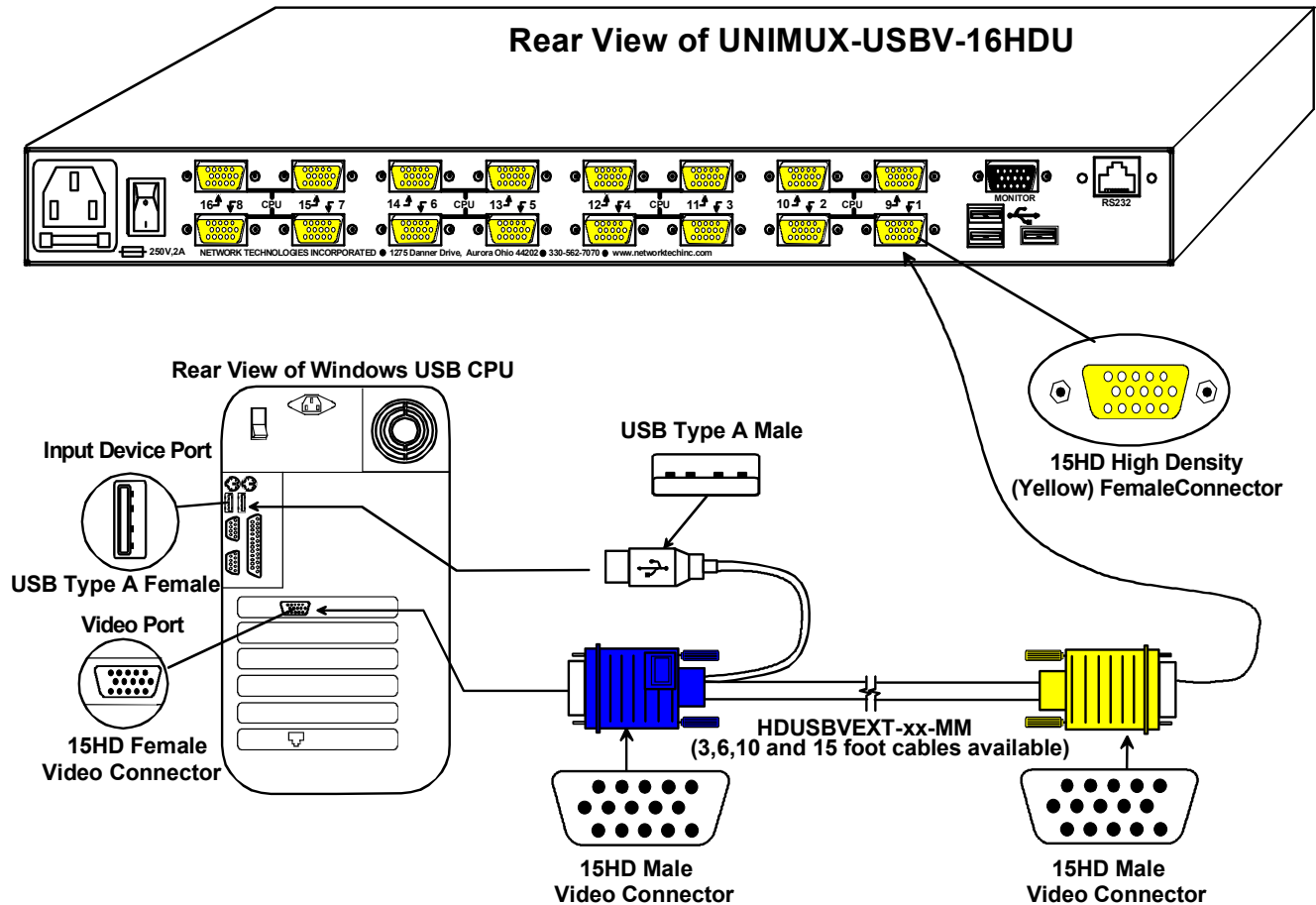

Figure 7- Connect each CPU using a HDUSBVEXT-xx-MM cable

4. Power-up

- The UNIMUX can be powered at any time.
- The CPUs can be powered at any time although if a CPU needs a keyboard and/or mouse at power-ON it should be powered after connecting to and powering-ON the UNIMUX.
- USB input devices (keyboard and mouse) can be hot plugged to and from the UNIMUX at any time.

Note: The order in which the CPUs and switch are powered up does not matter. A power strip can be used.

Immediately after powering ON the UNIMUX, the following splash screen will appear on the monitor if the OSD option is built into the switch:

If the security option is enabled (see page 12 for details on the "Security Option"), when the UNIMUX is powered up the user will be prompted for a username and password to continue. If the security option is not enabled the monitor will display the desktop image for the connected CPU and the user can continue with normal operation of the connected CPU.



RS232 Connection

If RS232 control will be used, connect one end of the CAT5 patch cable (supplied) to the port labeled "RS232" on the rear of the UNIMUX. Plug the other end of the CAT5 cable into either the RJ45-to-DB9 or RJ45-to-DB25 adapter supplied, and connect the adapter to the RS232 port on the control terminal. Follow the instruction under "RS232 Control" on page 31 for configuration and use of the RS232 control feature.

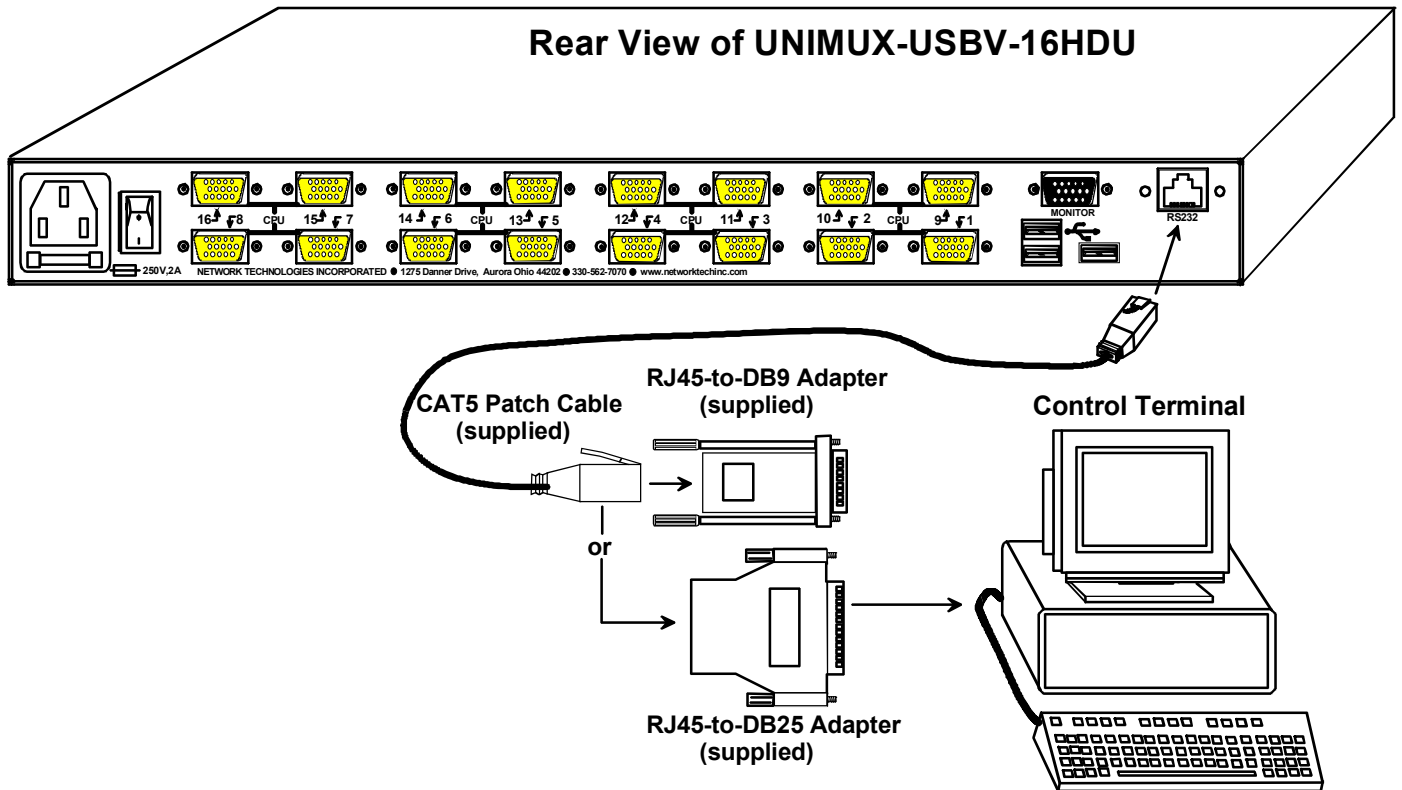

Figure 8- Connect cable for RS232 control

Limitations

- Only one non-HID (Human Interface Device) can be connected at a time (device other than keyboard or mouse)
- A USB hub (single or multi-port) can be used provided only USB input devices are plugged into it.
- Only a USB Windows or SUN keyboard or USB mouse may be connected to the USB port on a USB MAC keyboard
- A maximum of 5 input devices may be connected to the UNIMUX either directly or through hubs.

See Fig. 7 for some examples of input device combinations that can be used with the UNIMUX.

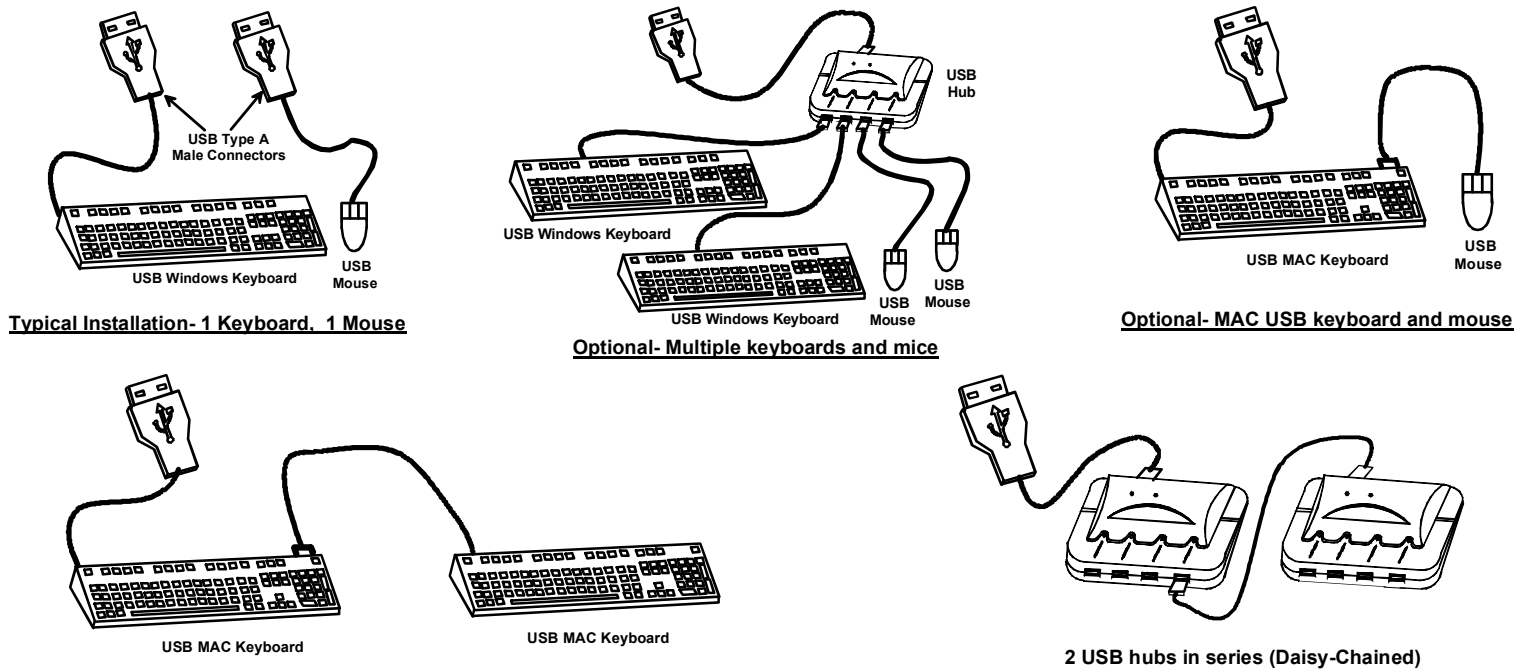

Figure 9- Compatible device combinations

USING THE UNIMUX USB KVM SWITCH

Basic Operation

Once the UNIMUX is properly connected, the UNIMUX will enable a connection to be made between the CPUs attached to its VIDEO and CPU ports and the monitor and input devices attached to the MONITOR and DEVICES ports. The LEDs on the control panel of the UNIMUX will illuminate depending on which port (and corresponding CPU) is being connected to the monitor and input devices.

The UNIMUX can be controlled by three methods:

- front panel control using touch-switches and LEDs
- OSD control via the user devices
- RS-232 control (see page 31)

Front Panel Control

There is a touch-switch and LED on the front panel of the UNIMUX for each CPU the switch will connect the monitor and input devices to. Pressing any touch-switch on the front panel of the UNIMUX will connect the corresponding CPU to the monitor and input devices.

Holding down any front panel touch-switch for more than 2 seconds will cause the UNIMUX to cycle through all modes of operation including COMMAND, BROADCAST, SCAN, and NORMAL (described starting on page 17). The three MODE LEDs on the front panel indicate which mode is selected. Release the touch-switch when the LEDs indicate the desired mode. When no mode LEDs are illuminated the user is in Normal Mode controlling directly the CPU to which the user is connected through the UNIMUX.

Keyboard Control

Keyboard control of the UNIMUX can be achieved using OSD Command Mode. Command Mode is operated using the keyboard and mouse in conjunction with OSD menus superimposed onto the monitor. For all models use the menus as instructed on page 12.

By pressing <Ctrl> + <`> (accent key), the user can enter Command Mode. Once in Command Mode, typing a series of commands will cause the UNIMUX to connect the user to any one CPU connected to the switch. Pressing the <Esc> key will exit Command Mode.

OSD CONTROL

OSD superimposes a menu system on the user's video screen with a list of all connected CPUs. OSD allows CPUs to be named (with up to 12 character names). OSD then allows selection of CPUs by that name. Connected CPUs can be listed by name or by port number. OSD Search Mode enables the user to type in the first few characters of the CPU's name and the OSD will locate it. HELP screens assist with all OSD functions.

Guidelines for Navigating OSD Menus

Throughout this manual, various rules apply to navigating the menus used to control and operate the UNIMUX.

- *OSD menus can be navigated using the mouse, the arrows on the keyboard, hot keys (highlighted in red) and the <Page Up>, <Page Down>, <Home>, <Tab> and <End> keys.*
 - *The <up arrow> and <down arrow> moves the cursor up or down one line item at a time in a scrollable window, or between menu items in a menu item list*
 - *The <left arrow> and <right arrow> will move the cursor left or right through menu items or while in editable fields (such as when editing port names)*
 - *<Page Up> and <Page Down> increase/decrease the listed ports by one page at a time*
 - *<Home> will jump to the beginning of the list*
 - *<Tab> will jump between selectable fields, left to right to move between menu items*
 - *<Shift>+<Tab> will jump between selectable fields, right to left*
 - *<End> will jump to the end of the list.*
- *Only alphabetic and numeric characters can be typed in the OSD menu fields*
- *Positioning the mouse cursor over a menu function or CPU name will highlight the background (green highlight for menu functions, cyan or light blue for CPUs)*
- *The scroll bar can be used by clicking on the corresponding up and down arrow above and below the scroll bar.*
- *The mouse wheel may be used to move the selection bar*
- *The <Shift> key must be used to enter an uppercase letter within all OSD menus.*
- *Clicking on a listed CPU while in Command Mode will connect the user to that CPU.*
- *Available functions will have white characters with one red character. The red character corresponds to a keyboard "hot key". Hot keys are not case sensitive. Functions that are not available will be transparent.*
- *When changing characters for names, passwords, or values within an edit field, click on the field or select and press <Enter> to enter the field for editing, and press <Enter> again to exit the edit field.*
- *To exit (and step back 1 menu) from any menu, press <Esc> on the keyboard .*
- *All screens that include "F1:Help" for context-sensitive help will also respond to pressing the <F2> key to provide "Global Help" screens with basic menu navigation help.*

Security Option

The security option in the OSD Control of the UNIMUX USB KVM switch enables an administrator to control access to CPU ports for each user. Up to 63 users can be created. These users have controlled access to any CPU. Only the administrator can activate or deactivate the security features on the user port. Finally, the administrator can set a maximum idle time value after which the current user will be logged out and the login screen displayed again if the user has no activity. The current security status, idle time out, and scan dwell time are all saved and will be restored whenever power to the switch is cycled OFF, then ON. To reset the administrator's password call NTI and have the device serial number of the UNIMUX available. For more on security, see page 20.

Initial startup

When the UNIMUX is first powered ON, a splash screen similar to the following will appear:



Press any key and the UNIMUX will connect you to the first CPU port with a connected CPU that is powered ON.

To access Command Mode and connect to a different port or perform other user access functions (see below), press <Ctrl> + <~> (accent/tilde key).

User Access Functions

Command Mode

In order to control the switch with the keyboard, Command Mode must be enabled. To enable Command Mode from the keyboard:

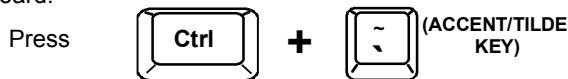

All the status lights on the keyboard will illuminate to indicate that Command Mode is enabled. At this point, the Command Mode menu will be displayed.

The Command Mode menu (see Figure 10) lists all CPUs by name and port number. Only 8 ports are listed on the screen at a time. To view the other portions of the list, scroll using the arrow keys on the keyboard or use the mouse to click on the arrows on the scroll bar in the OSD menu. When the Command Mode main menu is displayed, the first displayed port in the list will be the port the current user is connected to, followed by the next seven consecutively numbered ports. (Alternatively the list may be sorted alphabetically- press the letter <O> to toggle sort method.) The names of accessible ports are displayed with blue characters. If Security is activated, the access rights for the user logged-in may not include all ports. Names of restricted access ports are displayed in black.

Note: In a cascaded system (see page 37), if a switch is connected to a port, all the names of the ports of the slave switch will be displayed instead of the name of that port of the master switch. This rule applies recursively to all slave switches. If one of the slave switches is powered-OFF during operation, the Status field in the ports name list will display question marks. In this situation, the user should either power-ON the slave switch or send an Update Configuration Command (<Ctrl> + <Tab>). If the slave switch is powered back ON without updating the configuration and security is enabled, the text in the window for CPU type and power status will turn red until the configuration is updated. (The red text indicates that the slave switch was logged out.)

An arrow to the left of a port number in the list indicates the port the user is currently connected to. From left to right, the columns display the following:

- Port Number
- Port Name
- Power Status of the CPU (ON/OFF)

Note: "NAC" indicates a non-accessible compute. for that user

- The actual user number (1-8) connected to the CPU.
 - If no user is connected to a CPU, the user number is replaced by a "-" (dash).

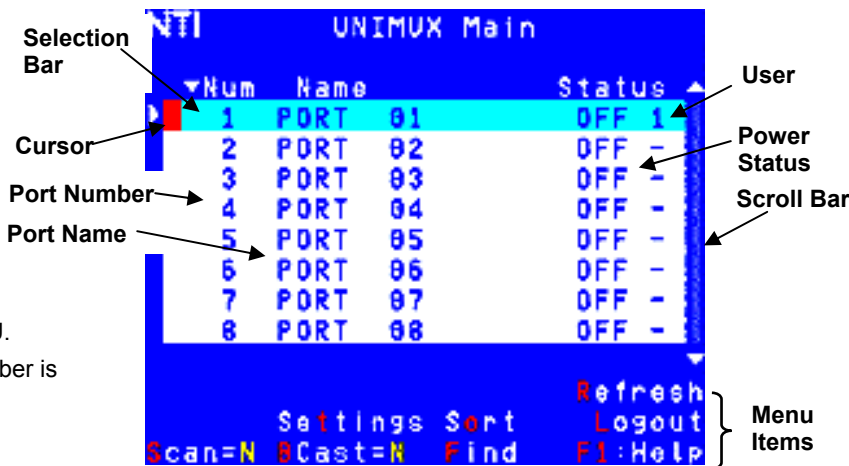

Figure 10- Command Mode main menu-User

Note: While in Command Mode, the numbers on the NUM PAD on the keyboard are not active. If numbers are required while in Command Mode, use the numbers on the main key bank.

The list below describes the command functions available from the keyboard within the OSD mode of control after entering into Command Mode:

Function	Keystroke
Select the previous port	up arrow
Select the next port	down arrow
Go to specific port- Press any valid number from 1-1024 to connect to a desired port.	port # - Enter
Increases the ports listed by 1 page	Page Down
Decreases the ports listed by 1 page	Page Up
Enter "Settings" menu	T
Toggle ports listed to view by port number or alphabetically by port name	O (letter, not number)
Enable/disable Scan Mode	S
Enable/disable Broadcast Mode	B
Enter Administrator menu (only available if the Administrator is logged in)	A
Select the first port on the switch	Home
Select the last port on the switch	End
Display Help menu	F1
Global Help- display window navigation tips used throughout all menus	F2
Display port information- when pressed, a window displays the port name and its position in the configuration structure by level and port number	F3
Update configuration- use to update the information describing the structure of the cascaded switches. Use if a slave is powered-ON or OFF at any time after initial startup	R or F5

Note: The user must exit Command Mode to type to a CPU.

To exit Command Mode press <Esc> on the keyboard.

Function	Keystroke
Enter Find Mode, add a character to search string and select the CPU's name that matches best. Type any alphabetical or numeric character (A-Z, 0-9) <i>Note: use is not case sensitive</i>	F
Switch to selected port	Enter
Logout (you will be prompted for confirmation)	L
Exit Command Mode	Esc

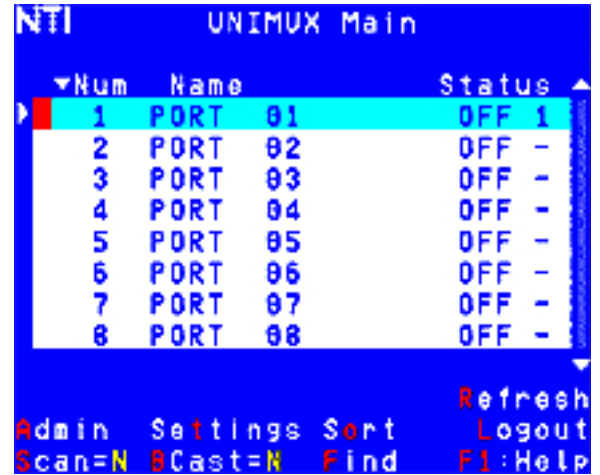

Figure 11- Administrator's main menu

Settings

To enter the Settings menu (see Figure 12) press <T> from the Command Mode menu. The list below describes the Settings menu functions available from the keyboard:

Function	Keystroke
Open OSD Settings screen	O
Go to Broadcast list	B
Go to Scan list	S
Change the scan dwell time period Enter any value from 002-255 (for more on this-see "Scan Mode" page 17)	T
Enable/Disable right mouse button click emulation with Apple 1-button mouse (see "Mouse Click Equivalents" on page 29 for more)	R
Exit from Settings menu Return to Main menu	Esc



Figure 12- Settings menu

When the <T> is pressed, the current value of the scan dwell time is selected with an edit field (see Figure 12) . The user can introduce a new value for scan dwell time and press <Enter> to save it or <Esc> to exit. Any value between 002 and 255 (seconds) is acceptable.

OSD Settings

The OSD Settings screen enables the user to adjust the height of the OSD screen on the monitor and the position of it. The position can be adjusted both horizontally, as well as vertically. Press <O> from the Settings menu (page 15) to open the OSD Settings screen.

Function	Keystroke
Make OSD window taller	T
Make OSD window shorter	S
Move OSD window vertically	up or down arrow
Move OSD window horizontally	left or right arrow
Exit and save OSD Settings	Esc



Figure 13- OSD Settings screen

Find Mode

Find Mode is enabled by typing any alphabetical or numeric characters while in the Command Mode main menu, or by pressing <F> while in supporting menus.

Find Mode allows the user to enter and maneuver through a list of CPU names. The CPU name best matching the characters typed is selected. The list of CPUs may also be searched for a specific (or similar) name. The Find Mode function is not case sensitive. The following commands are valid when the search option has been invoked from Command Mode.

Function	Keystroke
Erase previous character in search name	Backspace
Add a character to the search string and select the best matching CPU name	A-Z, 0-9 (upper or lower case)
Exit Find Mode	Esc or Enter

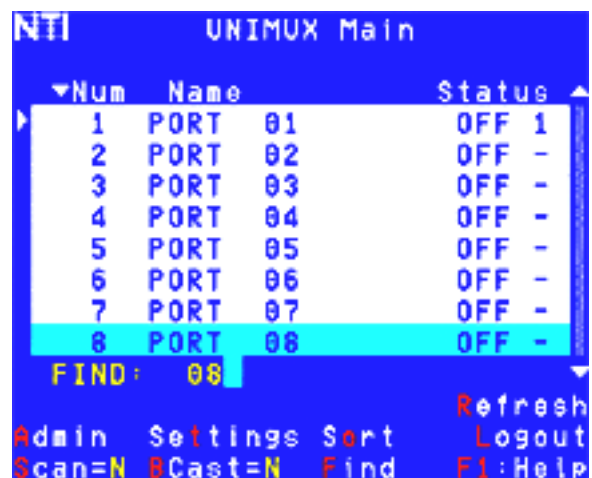

Figure 14- Find Mode in use

Help Mode

To enter Help Mode press the <F1> key from the Command Mode menu (see page 13).

Help Mode displays a list of commands with a short explanation of their function. The following options allow the user to quickly obtain information on any command.

Function	Keystroke
View the previous page of help if available	Page Up
View the next page of help if available	Page Down
Exit Help Mode	Esc



Figure 15- Main Menu help screen

Scan Mode

Using Scan Mode, the user can automatically switch from one CPU to another in predetermined configurable time intervals. The CPU ports to be scanned are easily selected provided the user has access to them. At initial startup, the user has access to all CPU ports by default.

To activate or deactivate Scan Mode press <S> from the Command Mode menu. The text shown in the menu (see Figure 11) will toggle between "Scan=N" and "Scan=Y", each time the <S> key is pressed. When "Scan=Y" is shown, Scan Mode is active. When "Scan=N" is shown, Scan Mode is OFF.

From the Settings menu (see page 15) press <S> to access the "Scan List". The Scan List enables the user to select specific ports to be active in Scan Mode. While active, the user will have full device control of the connected port. Only the selected ports will be scanned in Scan Mode.

The "Scan List" is a check list with all the port numbers displayed

- unchecked box = the corresponding port is **not** in the scan list
- checked box = the corresponding port **is** in the scan list

From the "Scan List" the user can:

- toggle the state of the selected port (press <Spacebar>)
- select all ports to be scanned (press <A>)
- deselect all ports so that none are scanned (press <N>)
- find a specific port to either select or deselect (press <F> , then any alphabetical or numeric character to locate the desired port).

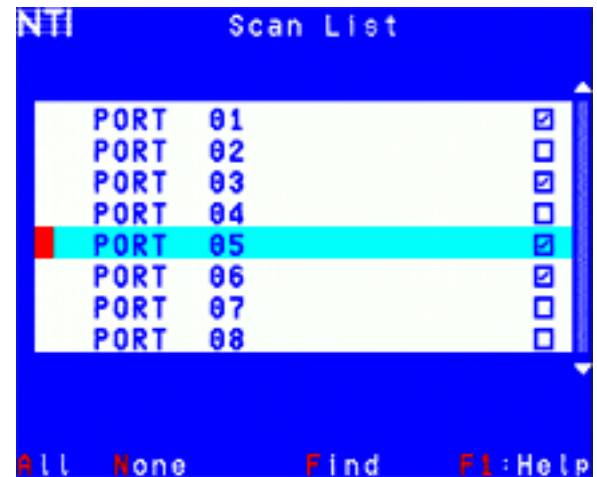

Figure 16- Scan List

A port is skipped from the scan cycle if one of the following conditions is true:

- the port is not in the Scan List
- Security Mode is enabled and the user does not have access rights to the port
- the CPU connected to the port is OFF

When switching to a new port the port name is displayed by OSD in the left upper corner of the monitor for 5 seconds or until a key is pressed or the mouse is moved, whichever comes first. The **scan dwell time** is programmable from 2 to 255 seconds (default time-out period is 5 seconds). While using the mouse, keyboard or touchscreen the scanned port becomes active and scanning is stopped. The switch will resume scanning after a period of user inactivity determined by the scan dwell time. See Settings Menu on page 15 for configuring the scan dwell time.

To return to the Settings menu, press **<Esc>**. The scan selection list is automatically saved.

Note: The scan dwell time set by the user only affects that user and has no effect on other switch users.

Note: The keyboard, mouse and touchscreen must remain idle for the full scan dwell time before the switch selects the next active port.

Broadcast Mode

To activate or deactivate Broadcast Mode press **** from the Command Mode menu. The text shown in the menu (Figure 11) will toggle between “BCast=N” and “BCast=Y”, each time the **** key is pressed. When “BCast=Y” is shown, Broadcast Mode is active. When “BCast=N” is shown, Broadcast Mode is OFF.

Broadcast Mode enables the user to type characters to more computers simultaneously. From the Settings menu (see page 15) press **** to access the “Broadcast List” where the user can edit the list of ports that receive data in Broadcast Mode.

The “Broadcast List” is a check list with all the port numbers displayed

- unchecked box = the corresponding port is **not** in the broadcast list
- checked box = the corresponding port **is** in the broadcast list

From the “Broadcast List” the user can:

- select all ports to be broadcasted to (press **<A>**)
- deselect all ports so that none are broadcasted to (press **<N>**)
- select only a limited number of ports to be broadcasted to
- find a specific port to either select or deselect (press **<F>** , then any alphabetical or numeric character to locate the desired port).

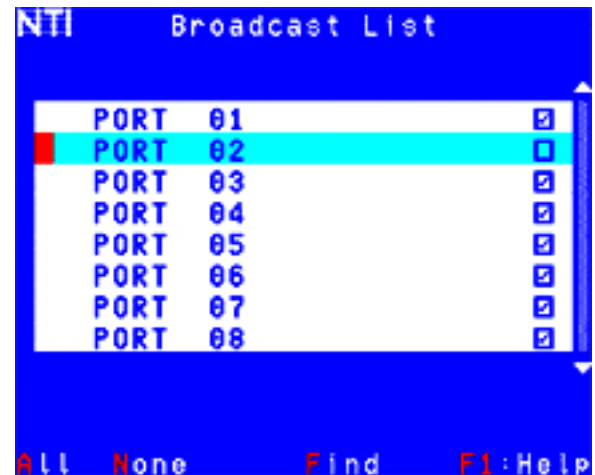

Figure 17- Broadcast List

A port doesn’t receive broadcast data if one of the following conditions is true:

- the port is not in the Broadcast List
- Security Mode is enabled and the user does not have access rights to the port

Note: The user must type somewhat slowly when in Broadcast Mode (less than 20 wpm) and cannot use the <Backspace> key.

Note: The mouse and touchscreen will be disabled while in Broadcast Mode.

To return to the Settings menu, press **<Esc>**. The broadcast selection list is automatically saved.

Normal Mode

When the UNIMUX switch is not in Command, Scan, or Broadcast mode and the OSD control is not active on the monitor, the user is in Normal Mode, controlling the CPU to which the user is connected through the UNIMUX switch.

F3- Display Information

To display information about a selected port, pressing the <F3> key from within the Command Mode main menu will cause a window to open (see below). The window will show the name of the port and its position in the system structure, level by level. This is most useful when cascading switches (see Cascading- page 37).

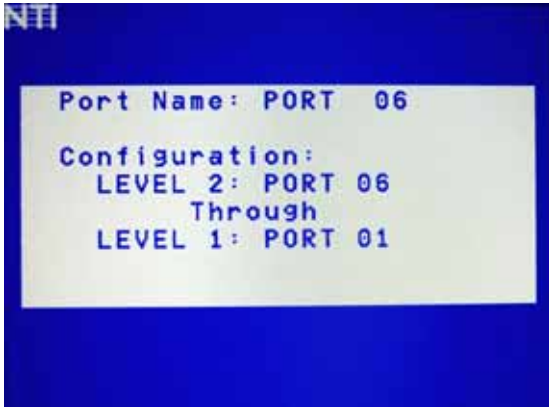

The image above indicates that the CPU connected to this port is actually connected through port 1 of the master switch (Level 1), and through port 6 of the slave connected to the master switch port 1 (Level 2). (See Figure 18.)

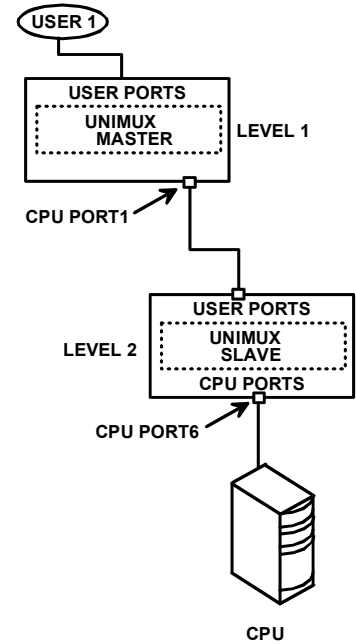

Figure 18- Port information- system structure

Security

Enabling Security

To enable the security feature the administrator must first enter Command Mode. If the Command Mode menu is not already displayed, press <Ctrl> + <`> (accent/tilde key). The OSD menu will automatically appear on the monitor.

To login as the administrator, the user must first logout by pressing <O>, and then <Y> to confirm. A login prompt will appear.

Password and User Name

The factory settings are:

- default user name = <root>
- default password = <nti>

Note: The username for the administrator cannot be changed from "root".

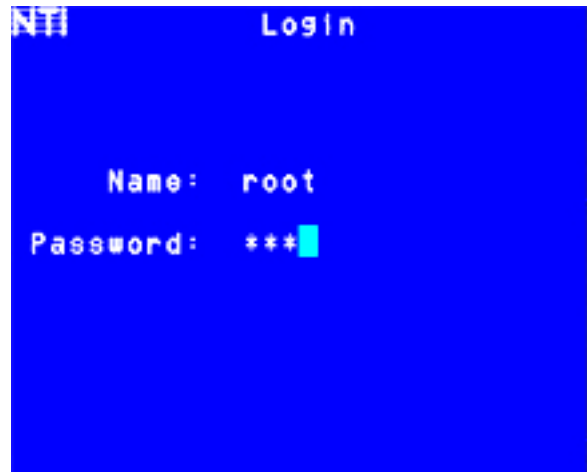

Figure 19- User login screen

Note: The <F1> Autologin key (see Figure 21) is only for use by users other than the administrator, and is only displayed and available for use if security is not enabled.

With a valid login, the user will be connected to the first CPU that is powered-ON. To enter Command Mode, press <Ctrl> + <`> (accent/tilde key). The OSD menu will automatically appear on the monitor.

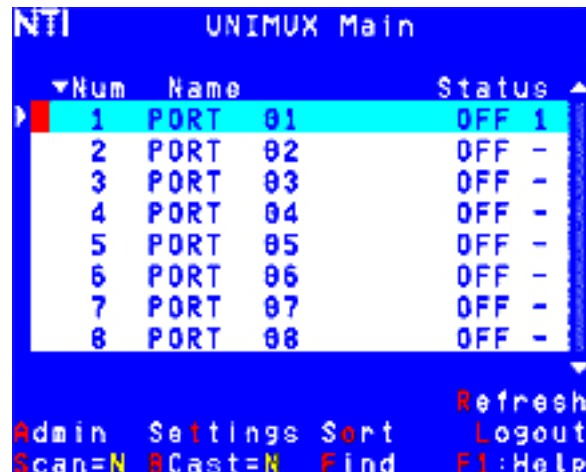

Figure 20- Administrator's main menu

The administrator will activate security (after logging in) by pressing <A>-<S>-<S>-<E> (see page 27).

Once logged-in, follow the instructions on page 21 for setting up users and changing the password. Once the password is setup, if it is lost or forgotten the administrator will have to contact NTI for assistance on clearing the password and set it up again. The administrator can setup each of the users and the limitations of their use of the individual CPUs using the administration menus.

When a standard user powers up the UNIMUX with security enabled, the login screen will appear. Enter the user name and password as set by the administrator. Unless a valid user name and password are entered, the login screen will remain on the monitor. For more on "User Login", see page 21.

User Login

User Login Mode requires a user to login with a user name and password from the list created by the administrator. The user will only be able to login if security is enabled. With security enabled, the user will be locked to the current CPU and the login screen will remain on the monitor until the user logs in.

Function	Keystroke
Autologin <small>(This is only available (but must be used when available) if security for the connected port is disabled)</small>	F1 <i>See note below</i>
Add a character to the user name/password <i>See note below</i>	A-Z /0-9 or Shift + A-Z (upper and/or lower case characters)
Remove previous character from the user name/password	Backspace
Submit user name/password	Enter
Move from Name to Password field	Tab or Enter



Figure 21- User Login screen with security disabled

If the password submitted is incorrect, the user will not be able to proceed.

If the password submitted is correct, the user will proceed to Normal Mode (see page 17).

Once a user name and password is accepted, the UNIMUX will connect to the first CPU that is powered-ON and the user has access to. To enter Command Mode, press **<Ctrl> + <`>** (tilde/accent key).

See the Command Mode functions described on page 13 to control the system of CPUs within the limitations as determined by the administrator.

Note: If security is not enabled, the message "Press F1 to Autologin" will appear in the login screen. While security is disabled, a standard user must press <F1> (see Figure 21) to access the switch. Only the administrator can login using the name and password when security is not enabled.

Additional OSD Modes Available With Security Enabled

Administration Menu

To access the Administration Menu press **<A>** from the Administrator's Main menu (see Figure 20). The Administration Menu can be accessed only when the administrator is logged-in. Users other than the administrator are not able to enter the Administration Menu.

If a different user is logged-in, log-out by pressing **<L>** from the Main menu, then log-in as Administrator. (See page 20, "Enabling Security".)

Administration Mode allows the administrator to use the following functions:

Function	Keystroke
Go to System Configuration menu	S
Go to Ports Configuration menu	P
Go to User Configuration menu	U
Change administrator's password	C
Display Usage Statistics	D
Exit from Administration Menu Return to Command Mode	Esc

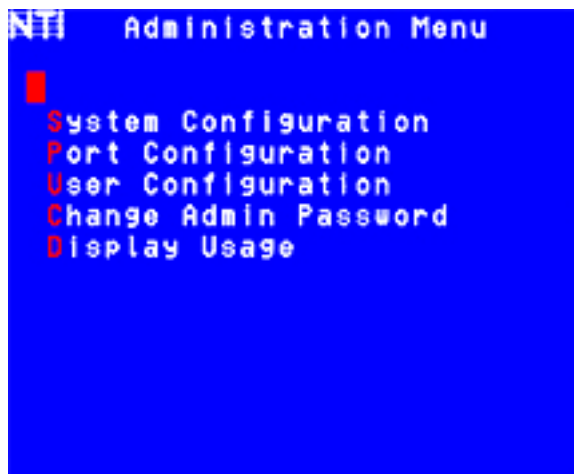

Figure 22- Administration Mode Menu

System Configuration

To enter the System Configuration menu: press <S> from the Administration menu. The System Configuration menu can only be accessed when the administrator is logged-in.

Function	Keystroke
Change Idle Timeout	I
Change OSD Blank Timeout	O
Change Alternate Command Hot Key (See page 26 for details)	A
Reset the port names to default settings *You will be prompted to confirm this selection* <i>Note: The UNIMUX must be power cycled or the OSD Refreshed (main menu) for the reset to take effect.</i>	R
Configure the Keyboard Language	K
Open Security Configuration menu	S
Serial Baud Rate	B
Serial Address	E
Exit from System Configuration menu and return to Administration Menu	Esc

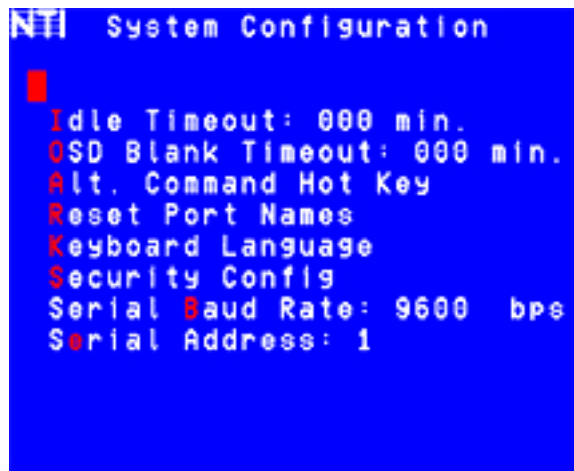

Figure 23- System Configuration menu

Port Configuration

To enter the Port Configuration menu: press <P> from the Administration menu. The Port Configuration menu can only be accessed when the administrator is logged-in.

The port configuration screen is used to edit the names of ports and to configure ports to be compatible with MAC or non-MAC CPUs. If the port will have a MAC CPU connected, use the mouse to click on the box associated with the port to place a check mark in the box.

Note: If a port is configured as connected to a non-MAC CPU, but is in fact connected to a MAC CPU, the mouse will still work as a generic mouse. No special functions provided by software drivers will be available.

Note: MAC mode must be enabled on any CPU ports that are connected to a CPU through an NTI ST-C5USBV extender.

Function	Keystroke
Open an edit field for the selected port to rename the port (see Figure 24). Names of CPUs can be up to 12 characters in length. Characters typed can be upper or lower case. Press <Enter> a second time to save the changes.	Enter
Configure all ports for MAC CPU connection	A
Configure all CPUs for non-MAC CPU connection	N
Open field in which you can type characters to quickly locate a specific port to be configured	F
Toggle the selected port between MAC and non-MAC configuration	Spacebar
Open Help window for this topic	F1
Exit from System Configuration menu and Return to Administration Menu. All changes made will be saved	Esc



Figure 24- Port Configuration menu

- To save the change to characters in an edit field, press <Enter>.
- To exit an edit field without saving the changes, press <Esc>.

User Configuration

To enter the User Configuration menu: press <U> from the Administration menu. The User Configuration menu can only be accessed when the administrator is logged-in.

The User Configuration screen lists the users configured to access the UNIMUX. Up to 63 users can be assigned access.

To assign a user name, password, and port access control, select the user number or an empty record and press <Enter>, <E>, or click it with the mouse.

Function	Keystroke
Select previous user in the list	up arrow
Select next user in the list	down arrow
Scroll to previous 8 names	Page up
Scroll to next 8 names	Page down
Edit account for selected user	E
Exit and return to previous menu	Esc



Figure 25- User Configuration

Edit User Account

The User Account mode (see Figure 26) enables the administrator to:

- add a new user
- remove an existing user
- edit the settings for an existing user

Function	Keystroke
Place edit field around the name- enabling it to be edited If no name is entered, a default name "userXX" (where XX is the user number) will be entered	N
Open an edit field to insert a user password- up to 15 characters in length If no characters are entered, no password will be required for that user	P
Usable characters for Name or Password (Upper and lower case characters can be used)	A-Z /0-9 or Shift + A-Z
Open an edit field to confirm the password by retying	C
Close an edit field	Enter
Open access control list for the user, to assign ports the user will be able to connect to For new users, by default, no ports are user accessible unless selected by the administrator	A
Delete all account information for the selected user	D
Exit and return to previous menu	Esc
Changes made will be saved automatically	



Figure 26- User Account menu

Note: To change the characters of a name while in the edit field, type the new characters or use the <Spacebar> to overwrite the existing characters. Pressing the <Delete> key will have no effect on existing characters and the <Backspace> key will only work if the cursor is at the end of the edit field. Use the <left arrow>, <right arrow>, <home> or <end> keys to move the cursor while in editable fields.

User Access Control

To enter the Access Control list for a user, press A from the User Account screen for that user. From the Access Control list the administrator can:

- select all ports to have access to
- deselect all ports so that none can be connected to
- select only a limited number of ports to be accessed

The Access Control list is a check list with all the port numbers displayed

- unchecked box = the corresponding port is **not** in the access list
- checked box = the corresponding port **is** in the access list

Function	Keystroke
Toggle the state of the selected check box	Spacebar
Select the next or previous port	up or down arrow
Quickly place check marks in all boxes	A
Quickly remove check marks from all boxes	N
Open Help window for this topic	F1
Exit and return to previous menu	Esc
Changes made will be saved automatically	



Figure 27- Access Control list

Change Administrator Password

To change the Administrator Password, press <C> from the Administration menu.

The Admin Password menu (see Figure 28) enables the administrator to change his password. Two edit fields are available, one for password, the other for verify password. The password can be up to 15 characters in length.

Note: The default password for the administrator is "nti".

Function	Keystroke
Switch between Password and Confirm (password) fields	Tab
Add character to password string or confirm string	A-Z, 0-9 (upper or lower case)
Delete previous character in edited string	Backspace
Save new password. (The administrator will be prompted for a Yes or No confirmation)	S
Exit and return to previous menu	Esc



Figure 28- Administrator password menu

Note: If the confirmation password does not match the first password entered, the message "INVALID PASSWORD" will be displayed when you try to save it.

Display Usage

To display usage statistics for the UNIMUX, press <D> from the Administration menu.

The Display Usage page shows the user how many times the UNIMUX has been power cycled and how many total hours it has been powered ON. The counters for these statistics can be reset to 0 by pressing <F7> to reset the number of power cycles or <F8> to reset the hours of usage.

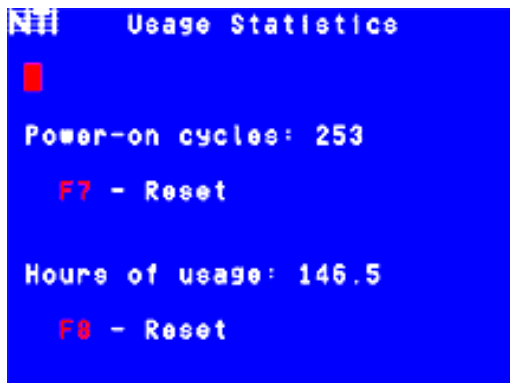

Figure 29- Usage Statistics Page

Idle Timeout

The idle timeout is the amount of time that the user can be idle while in Command Mode before the user is automatically logged out. The idle timeout can be set to any value from 000 to 255 minutes. A value of 000 will disable it. After the idle timeout period has elapsed, the login screen will appear.

To change the Idle Timeout setting,

1. press <I> from the System Configuration menu (page 22) to display the edit field around the value (see Figure 30)
2. enter the desired value (000-255 minutes)
3. press <Enter> to save it and move to the next field
4. press <Esc> to exit the System Configuration menu

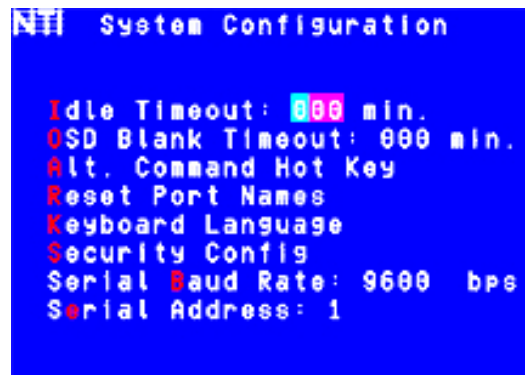

Figure 30- Change value of Idle Timeout

OSD Blank Timeout

The OSD Blank Timeout is the amount of time that the user can be idle while in Command Mode before the OSD menu will disappear. The time period can be set to any value from 000 to 255 minutes. A value of 000 will disable it. After the OSD disappears when the configured time period has elapsed, the user can make it reappear by either pressing a key on the keyboard or moving the mouse.

To change the OSD Blank Timeout setting,

1. press <O> from the System Configuration menu to display the edit field around the value (see Figure 31)
2. enter the desired value (000-255 minutes)
3. press <Enter> to save it and move to the next field
4. press <Esc> to exit the System Configuration menu



Figure 31- Change the value of OSD Blank Timeout

Alternate Command Hot Key

To enable the administrator to assign a key in addition to the <`> (accent/tilde key) to use with <Ctrl> to enter into OSD Command Mode, an Alternate Command Hot Key option is provided. The default factory setting for this option is <`> (disabling the option).

To select an Alternate Command Hot Key, press <A> from the System configuration menu (page 21). A window will open and the administrator will be prompted to press a key. Any key **except** Ctrl, Shift, Alt, Tab, Esc, or Enter can be used. After pressing the key, a confirmation message will appear. The administrator should press <Y> (Yes) to validate the key as the Alternate Command Hot Key, or <N> (No) to select another key.

Pressing <Esc> will return to the Administration Mode menu.

Only the administrator is able to set or change the Alternate Command Hot Key. This function must be set individually for each of the USB User Device ports on the UNIMUX USB KVM switch.

Note: The Alternated Command Hot Key does not replace the <`> (accent) key, it just works as another way to enter into Command Mode. After setting it, the user can enter into Command Mode either with <Ctrl> + <`> or with <Ctrl> + <Alternate Command Hot Key> combination. To disable it, the administrator should set <`> as the Alternate Command Hot Key.



Figure 32- Alternate Command Hot Key selection window

Reset Port names

To erase all configured port names and return them to the factory-default names, press <R> from the System Configuration menu. After pressing the key, a confirmation message will appear. The administrator should press <Y> (Yes) to validate the selection or <N> (No) to cancel it.

Pressing <Esc> will return to the Administration Mode menu.

The switch must be power cycled for the reset to take effect.

Select Keyboard Language

To enter the Select Language menu (see Figure 33) press K from the System Configuration menu described on page 22. Only the administrator has the Select Language menu option.

The Select Language menu enables the administrator to select a specific keyboard language (country code) to be used. Typically only SUN CPUs require a specific country code to be registered at boot up. (For other types of CPUs this feature may have no effect.) A list of available languages is displayed and can be scrolled using the mouse (scroll wheel) and/or <up arrow>, <down arrow>, <Home> and <End> keys.



Figure 33- Select Language menu

- To manually program a specific language, select a language and press <Enter> (or click the left mouse button).
- To automatically detect the language of the keyboard, select "AutoDetect" and press <Enter> (or click the left mouse button). The list will advance to the actual detected keyboard language and that language will be programmed.

Some keyboards don't have a country code. In this case the selection will remain in the "AutoDetect" position and the default country code "00" will be programmed in the UNIMUX. If a specific country code is manually programmed, it will be the country code for the switch, regardless of the actual country code of the connected keyboard. The programmed country code is saved in memory and restored each time the UNIMUX is powered-ON. Because the CPUs that use country code (i.e. SUN CPUs) read it at boot time, it is necessary to boot the CPU(s) after programming the country code.

Security Configuration

The UNIMUX can be configured to either have no security enabled such that any user can connect to the UNIMUX, or have security enabled such that a user must have a login name and password in order to enter Command Mode and make a connection with an accessible CPU. Only the administrator has access to Security Configuration.

Within Security Configuration, the administrator has three options:

Function	Keystroke
Enable security just for the user port that his currently connected through	U
Enable Global Security- security enabled on all user ports	E
Disable Global Security- security disabled on all user ports	D
Return to previous menu	Esc



Figure 34- Security Configuration

If Security is disabled for the port the user is connected to, and the user attempts to login to Command Mode with the command key, the login screen will include the instruction "Press F1 to Autologin".

With security disabled, Autologin provides full access to all connected CPUs and all users except the administrator must use it to login.

When security is enabled, Autologin is not available and the user must login using the administrator assigned user name and password. The user will have access to only those CPU ports as configured by the administrator.

If Global security is disabled, and security for the port the user is connected through is enabled, the user will only need to provide a username and password when connecting through that user port.



Figure 35- Login screen with security disabled

If Global security is enabled, the user must provide the username and password when connecting through any user port.

Serial Baud Rate

The serial baud rate for the UNIMUX can be changed by pressing from the System Configuration menu. In order to control the UNIMUX via RS232 (page 31), the baud rate must be set the same as the communication port on the control terminal attached to the UNIMUX (page 9)

The baud rate value can be set to 115000, 57600, 38400, 19200, 9600, 4800, 2400, or 1200. A data protocol of 8 data bits, no parity, and 1 stop bit is used for communications. With the edit field highlighted, press the <Left arrow> or <Right arrow> to change the value of the baud rate.

Note: The baud rate can also be changed from the RS232 Command Protocol (see page 31).

For more on RS232 Control, see page 31.



Figure 36- Adjust Baud Rate

Serial Address

To allow multiple UNIMUXs to be controlled from a single control terminal, the RS232 control interface is designed to allow "daisy chaining" up to 15 units. Each unit must be assigned a unique address. The unit address for the UNIMUX can be changed by pressing <E> from the System Configuration menu. With the edit field highlighted, press the <Left arrow> or <Right arrow> to change the value of the unit address. The address range is 1-15. For more on daisy chaining, see page 31.

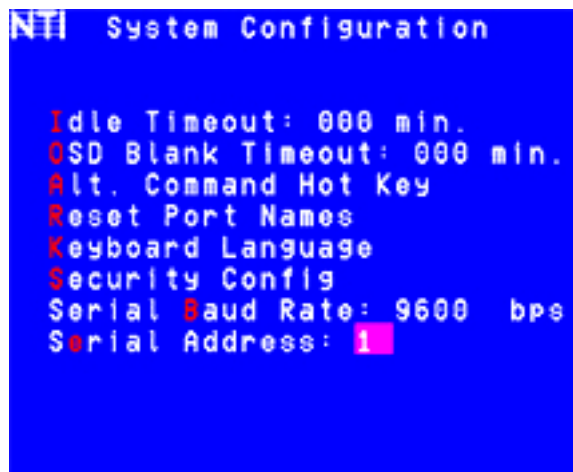

Figure 37- Adjust Serial Address

Keyboard Mapping

The keyboard configuration of each CPU is saved in the UNIMUX switch. For example, if the CPU attached to Port 4 had CAPS LOCK and NUM LOCK selected the last time that CPU was accessed, then they will automatically be set when that CPU is accessed again.

Key Equivalents

Using the chart below, find the character needed to be typed on the CPU being accessed, then follow the row across for the equivalent on the keyboard being used. (See Figure 38 on page 30 for reference.)

USB 101	WINxx	MAC (Apple USB)	SUN
L-Ctrl	L-Ctrl	L-Ctrl	L-Ctrl
L-Alt	L-Alt	L-Option	L-Alt
SB+F12	Application	SB+F12	Compose
R-Alt	R-Alt	R-Option	Alt-Graph
SB+Alt	Windows Logo	Command	Meta
SB+R Arrow	SB+R Arrow	Power	Suspend

SB = Space Bar

L and R = Left and Right keys when two keys are marked the same on a keyboard.

Mouse Click Equivalents

To emulate a right button click using Apple 1 button mouse, hold down the Command key () while pressing the mouse button.

Note: Right mouse button emulation must be enabled (see Settings on page 15) for this to work.

SUN's 16 Extra Keys

101, WINxx, MAC Keyboards	SUN Extras
SB+F1	Stop (L1)
SB+F2	Again (L2)
SB+F3	Props (L3)
SB+F4	Undo (L4)
SB+F5	Front (L5)
SB+F6	Copy (L6)
SB+F7	Open (L7)
SB+F8	Paste (L8)
SB+F9	Find (L9)
SB+F10	Cut (L10)
SB+F11	Help
SB+F12	Compose
SB + Up Arrow	Vol +
SB + Down Arrow	Vol -
SB + L Arrow	Mute
SB + R Arrow	Suspend

Use the chart to the left to type SUN's additional 16 keys using a 101, WINxx, or MAC (Apple) USB keyboard

SB= Space Bar

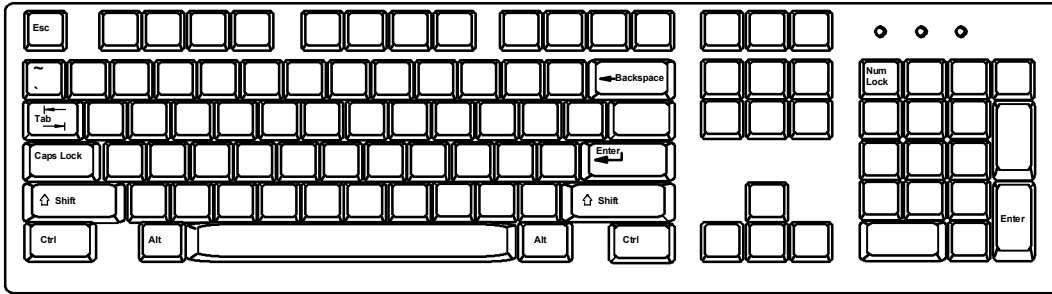

Typical 101 Keyboard

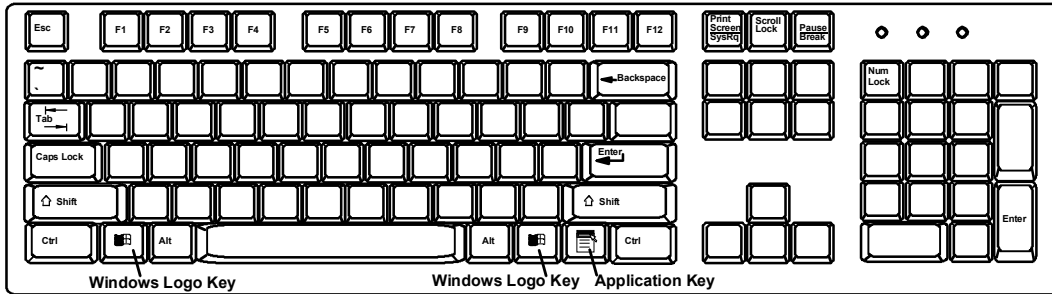

Windows Keyboard

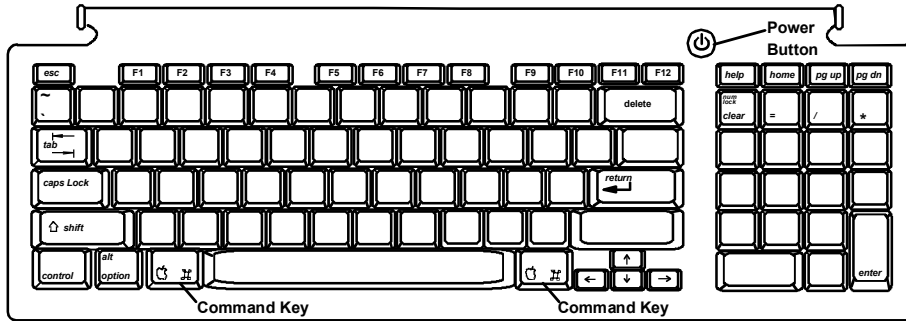

Apple USB Keyboard



SUN USB Keyboard

Figure 38- Keyboard layouts

RS232 CONTROL

RS232 enables the UNIMUX to be remotely controlled via RS232. To control the UNIMUX via RS232 the user has three options:

- write a program that runs on a PC using the Command Protocol (page 33)
- use the NTI Switch Control Program (page 34) provided on the CD
- use the SerTest or RMTEST programs (pages 34 and 36) provided on the CD

Remote Connection

The RS232 Interface is designed to meet the RS232C standard and can be controlled from any CPU or other controller with an RS232 communications port. The pin-out for the RJ45 connector on the unit is as follows:

RS232 (RJ45) CONNECTOR

PIN	SIGNAL	FUNCTION
1	-	No connection
2	-	No connection
3	RX+	Receive data (TXD at host)
4	GND	Ground
5	-	No connection
6	TX+	Transmit data (RXD at host)
7	-	No connection
8	-	No connection

NOTE: Security must be disabled or user access granted on the port(s) to be selected by RS232 control.

A 5 foot patch cable and two adapters, RJ45-to-DB9 and RJ45-to-DB25, have been provided for connection to most CPUs (see page 9). To daisy chain multiple units, connect a Matrix-Y-1 cable (sold separately) between the CPU and the first switch, and between each switch (as shown in Figure 39).

Baud Rate

The baud rate can be changed using the OSD menu (page 31) or from the RS232 commands (page 33). The baud rate can be set to 115000, 57600, 38400, 19200, 9600, 4800, 2400, or 1200. A data protocol of 8 data bits, no parity, and 1 stop bit is used for communications.

Unit Address and Loop Back

To allow multiple units to be controlled from a single host port, the RS232 control interface is designed to allow "daisy chaining" up to 15 units using an NTI Matrix-Y-1 cable. Connect the Matrix-Y-1 cable between the RJ45-to-DB9 serial adapter and the CPU as shown in Figure 39. By setting the appropriate unit address (page 31), each unit can be given a unique address (1-15). Then the unit will only respond to commands on the bus if its address is embedded in the command.

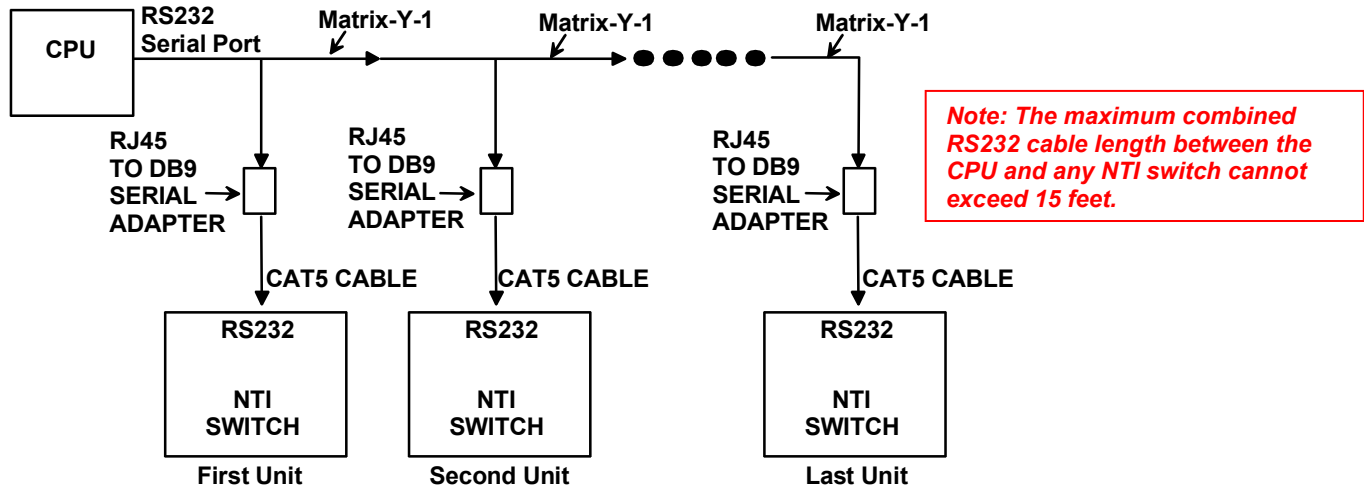

Figure 39- RS232 connection with Matrix-Y-1 cable

Wiring Schematic of Matrix-Y-1 cable

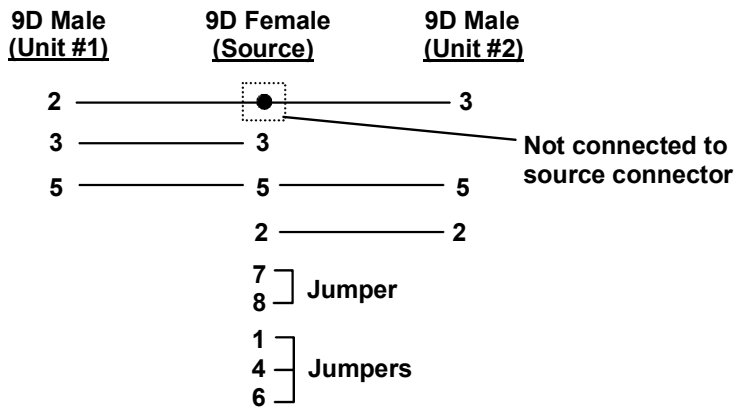

Figure 40- Pinout of Matrix-Y-1 cable

RS232 Command Protocol

Host controller commands supported by the unit are defined below.

RS232 Command Protocol Quick Reference

Legend: (All numbers must be two digits)

SW : Switch (01-15)

IP : Input Port/CPU (01-MAXINPUTS)

BR : Baud Rate Code

<CR>: Carriage Return (Hex 0xD)

OP : Output/User Port (01-MAXOUTPUTS)

Command String	Good Response	Description
CS SW,IP,OP	*<CR>	Connect one User port To CPU port
RO SW,OP	*<CR>IP<CR>	Read Connection For User Port
CB 00,BR	None	Change Baud Rate For All Switches BR = 12 (1200), 24 (2400), 48 (4800), 96 (9600), 19 (19200), 38 (38400), 57 (57600), 11(115000) (9600 is the default)
RV SW,00	*<CR>string\0<CR>	Read NTI Version String
RU SW	*<CR>IP,OP<CR>	Read Unit Size
SS SW,00	*<CR>	Disable Autostatus feature (see below)
SS SW,01	*<CR>	Enable Autostatus feature (see below)
GO SW OP	*<CR>go SW OP IP<CR>	Report the User port that is connected to the CPU port
GM SW,00	*<CR>go SW OP IP<CR> (all connections)	List all switch User port connections; all User ports to all CPU ports

If the first field is not a known command (as listed above) or SW field is different from the serial address programmed in the switch memory, the command will be ignored. If the SW field corresponds to the serial address, but the syntax is wrong after this field, the switch will answer with ?<CR>.

Syntax example:

CS 01,05,02<CR> (insert the space and commas as shown)

which means “At the switch with unit address 01, connect CPU port 05 to user port 02”

The switch will answer with:

***<CR>**

The HEX code representation of example above is:

Byte 1	Byte 2	Byte 3	Byte 4	Byte 5	Byte 6	Byte 7	Byte 8	Byte 9
'C' (0x43)	'S' (0x53)	Space (0x20)	Switch – 1st digit (0x30)	Switch – 2nd digit (0x31)	',' (0x2C)	Output – 1st digit (0x30)	Output – 2nd digit (0x35)	',' (0x2C)

Byte 10	Byte 11	Byte 12
Input –1st digit (0x30)	Input –2nd digit (0x32)	<CR> (0x0D)

Response:

Byte 1	Byte 2
'*' (0x2A)	<CR> (0x0D)

Autostatus

When Autostatus is enabled, any output-to-input connection change in the UNIMUX will cause an Autostatus message to be sent via RS232 to the administrator. The format of the message would be "pc SW,OP:IP<CR>"

Example of an Autostatus message:

```
pc 01,01:04<CR>
```

which means "At the switch with unit address 01, the output (01) has changed connection to input 04."

Notes: Message to the administrator will be delayed by any RS232 traffic being received by the switch from the administrator.

Autostatus must be disabled before using SerTest or the NTI Switch Control Program (below).

By default, Autostatus is disabled and must be manually enabled. Autostatus is also disabled any time the power to the UNIMUX is interrupted.

NTI Switch Control Program For Windows 9X, NT, 2000, XP and Vista

The NTI Switch Control Program is an easy and powerful graphical program that controls NTI matrix switches through an RS232 interface. The NTI Switch Control Program is included on the CD packaged with the UNIMUX. The NTI Switch Control Program is downloaded by clicking on the link "Download NTI Switch Control Program" found on the webpage the opens when the CD is inserted into the CDROM drive.

To install the NTI Switch Control Program after downloading

1. Locate the **Setup.exe** in the directory the program was downloaded to and double-click on it
2. Follow the instructions on the screen

Note: In order to use the NTI NTI Switch Control Program to control the UNIMUX, the UNIMUX RS232 port must be set at a baud rate of 9600 bps (see page 31).

The NTI Switch Control Program performs best on monitors set to a screen resolution of at least 800 X 600. Instruction for using the NTI Switch Control Program is available by opening "MSCP Help" in the "NTI" program group once the program has been installed and is open on the screen.

To open "MSCP Help" from the Windows desktop

1. Click on **START**
2. Click on **PROGRAMS**
3. Click on **NTI**
4. Click on **MSCP Help**

SerTest- RS232 Interface Test Program

This software allows a user to test the functions of an NTI server switch, matrix switch or Multi-user/Multi-platform switch RS232 interface. The program SERTTEST along with the NTI Switch Control Program (page 34) is installed from the CD packaged with this switch. SERTTEST generates a main menu with the selections described below:

Main Options

- Matrix Operations - send commands to the matrix unit.
- Ethernet Operations - set Ethernet connection variables (not applicable to this product)
- Setup Options - set COM port, baud rate, and unit address
- About SerTest - display the program version

Matrix Operations

Key	Selection	Description
1)	Connect Output/User to an Input/CPU	- connect an output to an input
2)	Connect All Outputs/Users to an Input/CPU	- connect all outputs to an input
3)	Connect Audio Output/User to an Input/CPU	- connect an output to an input (audio ports only)
4)	Connect All Audio Outputs/Users to an Input	- connect all outputs to an input (audio ports only)
5)	Change Mute Status for Audio Output/User	- mute or un-mute the Audio port output
6)	Change Volume for Audio Output/User	- change Audio port output volume
7)	Read Connection for Video Output/User	-read the connection of a specific video output
8)	Read Connection for Audio Output/User	-read the connection of a specific audio output
9)	Read Mute and Volume for Audio Output/User	- read the volume and the mute status of the specified output (audio ports only)
a)	Save I/O Connections into Unit Memory	-save the connections into switch memory bank
b)	Restore I/O Connections from Unit Memory	-restore the connections from switch memory bank
c)	Change All Units Baud Rate (9600/COM1:)	-change RS232 Baud rate of all switches -the current baud rate and serial port are displayed in parentheses
d)	Reset Unit	- send a reset command to the switch (This command does not function at this time)
e)	Reset All Units	- send an internal reset command to all switches
f)	Read Unit Size	- read the switch size (number of inputs and outputs)
g)	Read Unit Version/Revision String	-read a string containing the switch version, type, and size
h)	Save All Units I/O Connections into Units Memory	-save the connections into switch memory bank, command for all switches
i)	Restore All Units I/O Connections from Units Memory	-restore the connections from switch memory bank, command for all switches

Selections in the "Key" column that are gray are not applicable to this product.

Setup Options

Key	Selection	Description
1)	select Com port current: (COM1:)	- select PC serial port - the current PC serial port is displayed in parentheses
2)	select Baud rate current: (9600)	- select PC serial port baud rate - the current baud rate is displayed in parentheses
3)	set unit Address current: (1)	- select the unit address - the current address is displayed in parentheses

For any selection that requires user input, the user is prompted. When commands are sent to the matrix unit, the command string and matrix unit responses are echoed to the screen. All commands generated by the program are formatted according to the information provided in sections above. If any transmission problems are detected, an error message is displayed.

Press <Esc> or <Enter> to back out to the main menu and press again to exit.

RMTEST-RS232 Interface Test Program

This software also allows a user to test the functions of an NTI server switch, matrix switch or Multi-user/Multi-platform switch RS232 interface. The RMTEST program is automatically loaded when installing the NTI Switch Control Program as described on page 34. The RMTEST program, located in the NTI program group, generates a main menu with the 3 selections described below:

MAIN OPTIONS

1. Matrix Options - send commands to the matrix unit.
2. Setup Options - set COM port, baud rate, and unit address
3. Quit - quit the program

If Matrix Options is selected, the following menu, which has 7 options, is displayed:

MATRIX OPTIONS

1. Reset single unit - reset single matrix to power-up defaults (matrix switch only)
2. Reset all units - reset all daisy chained matrix units (matrix switch only)
3. Change single output - connect an input to one output
4. Change all outputs - connect an input to all outputs
5. Read single output - read which input is connected to an output
6. Read unit size - read how many inputs and outputs the unit has
7. Return to main menu - go back to the MAIN OPTIONS menu

The Setup Options main menu selection only needs to be executed if the switches baud rate or unit address have been changed from the factory defaults (9600 baud, and unit address = 1). When this option is selected, the following menu, which has 4 options, is displayed:

SETUP OPTIONS

1. Set COM port (default = COM1) - set port to COM1-COM3
2. Set baud rate (default = 9600) - set baud rate (see interface manual for supported baud rates)
3. Set unit address (default = 01) - set the unit address (if multiple units are daisy-chained)
4. Return to main menu - Go back to the MAIN OPTIONS menu

For any selection that requires user input, the user is prompted. When commands are sent to the matrix unit, the command string and matrix unit responses are echoed to the screen. All commands generated by the program are formatted according to the information provided in the sections above. If any transmission problems are detected, an error message is displayed.

CASCADING

The UNIMUX USB Matrix switch can be expanded to access up to 1024 CPUs by cascading multiple units together. As many switches as there are CPU ports may be connected to a UNIMUX USB Matrix switch. (See Figure 41) All downstream switches are referred to as "slaves" in a cascaded system. The only additional hardware required to cascade switches is a set of device and monitor cables for each "SLAVE UNIT" (see MATERIALS on page 2). All CPUs and switches can then be controlled by users using OSD commands with Command Mode.

Limitations

The front panel keypad is only used to operate standalone switches. To control a cascaded network of switches, only the OSD commands within Command Mode will be recognized.

Users connected to accessible ports on downstream slaves (i.e. ports not connected to the master) will not be able to control switches or CPUs connected upstream. Only control over CPUs and slaves downstream from a user's connection point will be enabled. (See Figure 41)

Slaves in a cascaded system must be either all single-user switches or all multi-user switches, but not a combination of both.

Cable Connections

The same cable used to connect a CPU to the UNIMUX is used to connect two UNIMUX-USBV-xHD switches together-HDUSBVEXT-xx-MM. No other cables will be necessary. To connect a slave to a master

1. Connect the USB-A-male end of the HDUSBVEXT-xx-MM to the USER port on the slave.
2. Connect the 15HD male at the same end of the HDUSBVEXT-xx-MM cable to the MONITOR port on the slave.
3. Connect the yellow 15HD male end of the HDUSBVEXT-xx-MM to the CPU 1 port on the master.

Repeat this procedure for each USER and MONITOR port on each slave that is desired to be controlled through the master.

The same procedure can be used to connect multi-user switches (UNIMUX-nXm-UHDU) as slaves (see Figure 42).

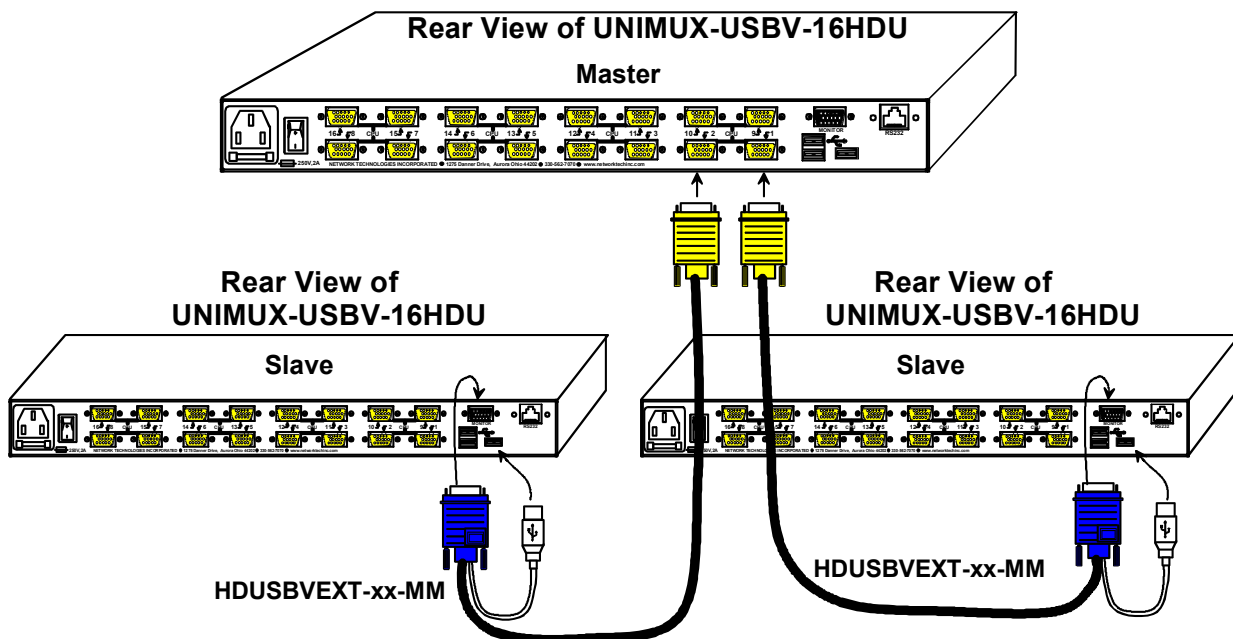

Figure 41- Cascading with only single-user units

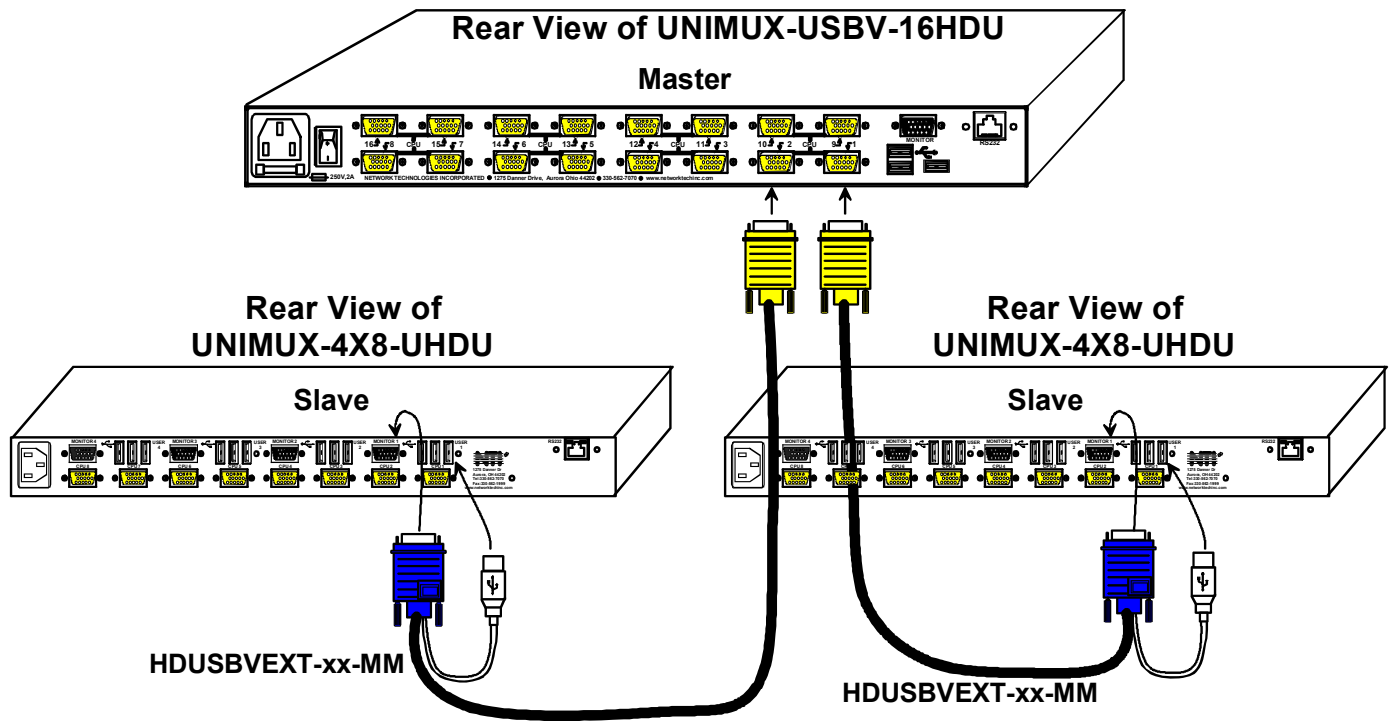

Figure 42- Cascaded connections with multi-user slaves

Operating Cascaded Switches

Immediately after powering-ON the Master switch, the following splash screen will display on the monitor:



All the downstream switches should be powered ON before pressing any key. If there are USB extenders connected, they should also be powered ON. An extra time of about 5 seconds after powering-ON the last unit may be needed to complete the USB enumeration process. If the switch is a standalone unit (no downstream switches connected), the key could be pressed immediately.

When a key is pressed, the master switch will start the process of detecting the configuration. This could take several seconds, depending on how many switches are connected together. When configuration update is ready, the splash screen disappears and the system is ready to operate. (If security mode is activated, the login window will be displayed on the screen). The update-configuration function can be recalled at any time by entering into Command Mode and pressing the <F5> key.

Note: If a slave switch is power cycled, use the Refresh command (page 14) to update the configuration.

After completing the configuration detection, the splash screen is turned OFF and the switches can be operated. All configuration can be controlled from the keyboard, mouse and monitor through OSD menus (page 12).

SUN RAY SUPPORT

The UNIMUX fully supports SUN Ray CPUs, however, a lack of horizontal mouse movement may be experienced. If this occurs, enable MAC mode (page 22) for the port that the SUN Ray is connected to. This should enable proper mouse movement.

FIRMWARE UPGRADE PROCEDURE

This procedure describes how to upgrade the firmware in this UNIMUX switch. If you are not certain whether this UNIMUX has the most up-to-date firmware available, see page 45 for instruction on how to determine what version the UNIMUX has. All versions of firmware can be downloaded from the NTI firmware download website at <http://www.networktechinc.com/download/d-srvsw-usb-hd.html>.

The UNIMUX switch has 3 types of micro-controllers:

1. Main User Controller – there is only one on each UNIMUX and it will be upgraded with a binary file named **unimux-suhd-csx-x.bin. (where x-x is the rev number)**
2. HID Port Controller – there is one HID Port Controller for each CPU port available on the switch – it will be upgraded with an Intel hex file named **unimux-suhd-cpkmx-x.hex**. Each CPU port is upgraded independently.
3. Vendor Specific Port Controller – there is one such controller for each CPU port available on the switch – it will be upgraded with an Intel hex file named **unimux-suhd-cpvdx-x.hex**. Each CPU port is upgraded independently.

The UNIMUX firmware has a bootloader which can be used for firmware upgrades. The bootloader resides in a protected area of Flash memory, so that if the upgrade fails for any reason, the bootloader will still be available to be used to re-program the entire unit.

Upgrades can be made to the User Controller, HID Port Controller, or Vendor Specific Port Controller on an individual basis as needed. Not all CPU ports must be at the same revision level for the UNIMUX to work, but it is highly recommended that if you upgrade one CPU port, you upgrade all CPU ports on a switch.

Requirements

- CAT5 Patch Cable (supplied with UNIMUX)
- RJ45-DB9 or DB25 Adapter (supplied with UNIMUX)
- Computer with a Terminal Console (for example, HyperTerminal in Windows, or any similar program able to send files using Xmodem protocol)
- Firmware files for the UNIMUX on the computer with the Terminal Console.

PREPARATION FOR UPGRADE

1. With the power to the UNIMUX OFF, connect the computer to the UNIMUX as shown in the figure below.

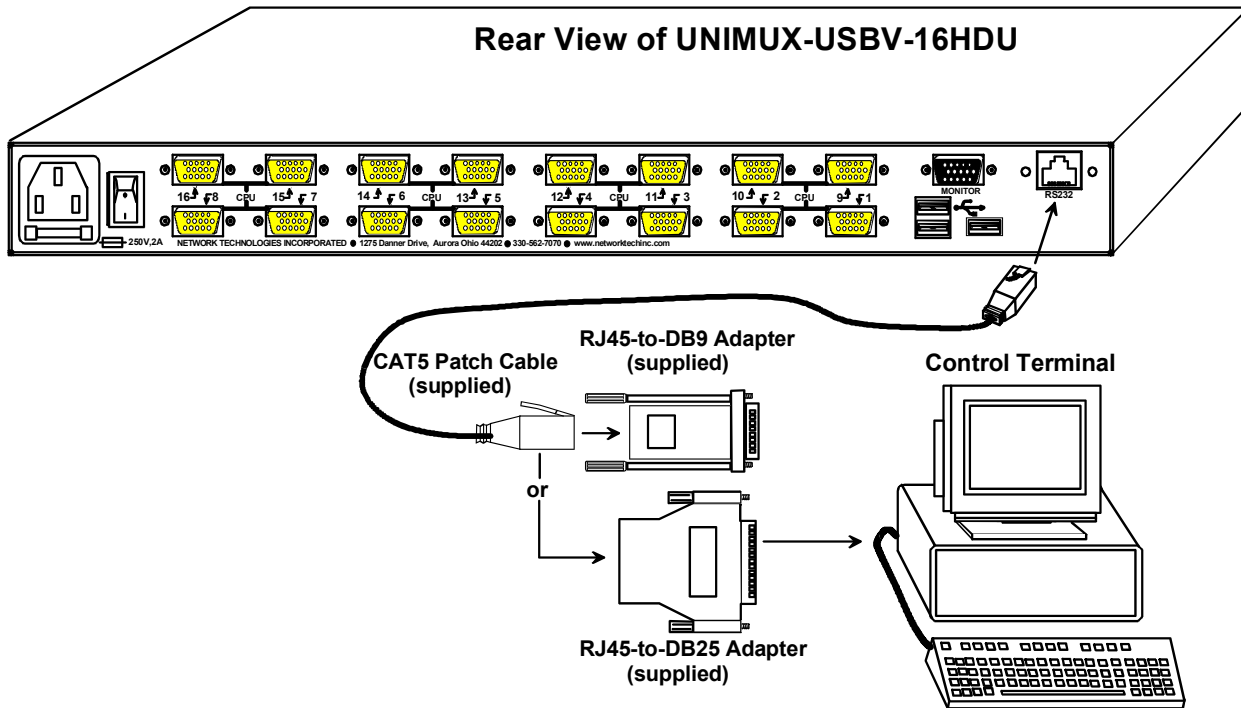

Figure 43- Preparation for firmware upgrade

2. Power ON the computer only. Open the terminal console and apply the following settings to the terminal console for the port connected to the UNIMUX:

Baud rate: 57600

Data bits: 8

Parity: none

Stop bits: 1

Flow control: none

UPGRADE PROCEDURES

Start the Bootloader

In the HyperTerminal window on the attached computer, press **and hold** the <Tab> key and power ON the UNIMUX. The following message (or one similar) will be displayed on the screen:

```
UNIMUX-HD-NxM Bootloader
Revision: 1.1
Date: 2008/09/11 15:40:16
Copyright (C) Network Technologies Inc.
```

```
Press <H> for help..
>
```

Release the <Tab> key.

The “>” prompt indicates that the bootloader is waiting for commands. The available commands are composed by sending one ASCII character. To send a command to the bootloader, type the key in the terminal window that corresponds to the desired command. The available commands, listed below, can be viewed by typing <h> or <H> (the Help command) from the keyboard.

Note: Commands can be typed using upper or lower case letters.

Commands:

```
h, H - Display list of commands
x, X - Exit Bootloader
u, U - Upgrade user controller firmware
p, P - Upgrade HID port controller firmware
v, V - Upgrade vendor specific controller firmware
s, S - Read Checksum of the HID port controller firmware
t, T - Read Checksum of the vendor specific controller firmware
```

Update the User Controller Firmware

Note: The User Controller Firmware update only needs to be done once, whether the UNIMUX switch is a single-user, or a multi-user model.

The user controller firmware comes as a file in binary format and has the extension .bin. (i.e. filename.bin). To upgrade the user controller to this file, press <u> from Terminal window. The following message should appear on the screen:

```
Erasing flash memory...
Memory successfully erased
Send .bin file using Xmodem protocol..
```

At this point the binary file **unimux-suhd-csx-x.bin** must be sent. To do this, from HyperTerminal:

1. go to "Transfer" menu in the Menu Bar of the HyperTerminal window
2. click the item "Send File ..."
3. in the dialog box which pops up on the screen, browse for the file to be sent and select it
4. select "Xmodem" from the Protocol drop-down menu
5. press "Send" button

The transmission will start shortly. Wait until the transmission is finished. There will be some pauses during transmission, since the processor writes blocks of 4KB.

When the transmission is complete, the HyperTerminal window should show the following status message and return to the menu prompt:

```
Device successfully programmed!
```

```
>
```

To exit from the bootloader, press <x>.

Update the HID Port Controller Firmware

The HID port controller firmware comes as a file in Intel Hex format and has the extension .hex (i.e. filename.hex). To upgrade any of HID controllers (there is one per CPU port) with this firmware, press <p> from the terminal window. The following message should appear on the screen:

```
Send .hex file using XModem protocol...
```

At this point, the hex format file **unimux-suhd-cpkmx-x.hex** has to be sent, using HyperTerminal and the same procedure as before. When the transmission is done, the following message will be shown in the HyperTerminal window:

```
File transfer OK!
Please, type the two-digit number of the port to be updated,
<A> to program all or <X> to exit
(the two-digit number should be between 01 and nn,
where nn is the number of available ports):
```

To **program only one device** (CPU port), the corresponding port number must be typed (two-digit number, zero leading, number between 01 and the last CPU port number, depending on switch size). To **program all devices**, just press <a>).

The following message will be shown on the screen (it may take about 12 seconds to program each device):

```
Programming device, please wait...
```

```
Device ID: 0x001E
```

```
Device successfully programmed!
```

The bootloader will then ask again for a port number.

To program another port, type the two-digit number of the port,

To exit from this function and the bootloader, press <x>.

If <a> was pressed instead of a single port number, and all devices were programmed, the message above will be repeated for each port that was programmed. After all are programmed, unless the switch has 32 CPU ports, the following message will be shown on the screen

```
Programming device, please wait...
```

```
Device ID: 0x0000
```

```
Device failed!
```

```
Error Code 1
```

This is shown because the bootloader continues to look for devices until it has found up to 32 (the maximum number of possible CPU ports a single UNIMUX can have). If it doesn't find another port, the procedure will fail and discontinue. On switches with fewer than 32 ports, this is normal.

To exit from the bootloader, press <x>.

Update the Vendor Specific Port Controller Firmware

Updating the vendor specific port controller firmware is similar to updating the HID port controller firmware (described on page 3). The only differences are that key <v> is used to enter this command and the hex file to send will be **unimux-suhd-cpvdx-x.hex**

To exit from the bootloader, press <x>.

Read the Checksum of HID or Vendor Specific Port Controller Firmware

Reading firmware checksum is useful to determine the version of software running on port controllers. While the firmware revision for user controller can be found on the UNIMUX splash screen when it is powered-ON, the firmware revision of port controllers is not displayed anywhere. Reading checksum is an easy way to identify the current firmware revision in your UNIMUX and to determine if a new firmware revision is available for download.

To read the checksum, type <s> for HID port controllers or <t> for vendor specific port controllers, at the bootloader prompt. The following message will be displayed:

```
Please, type the two-digit number of the port to be checked,  
<A> to check all or <X> to exit  
(the two-digit number should be between 01 and nn,  
where nn is the number of available ports):
```

To read the checksum for only one device, type the number of the port (two digits, leading 0). To read the checksum for all ports type <a>.

The device ID and the checksum will be displayed in the following format:

```
Device ID: 0x001E  
Device Checksum: 0x3AB1
```

The checksums for all revisions of UNIMUX firmware can be found on the NTI download webpage at <http://www.networktechinc.com/download/d-srvsw-usb-hd.html>.

To exit from the bootloader, press <x>.

SAFETY STATEMENTS

Grounding

These products have protective earth ground terminals and are built with full attention to consumer safety. There must be an uninterrupted safety earth ground between the main power source and the product's power cord or supplied power cord set.

If ever the possibility exists for the grounding protection to have been reduced in any way, disconnect the power supply until the grounding connection has been fully restored.

Servicing

NTI products are not intended to be serviced in the field and contain no user-serviceable parts. In the event repair is needed, all servicing must be performed by factory trained and authorized service personnel. Only those items specifically identified in this manual (if any) may be adjusted by the user of this product and adjusted only as instructed in this manual.

CABLES

NTI #	DESCRIPTION
HDUSBVEXT-3/6/10/15-MM	Connect each CPU to the UNIMUX-UHD with one
USBVEXT-3/6/10	VGA and USB extension
USBVEXT-3/6/10/15-MM	VGA and USB interface
USB-AA-5M	Connect up to 5 cables in a series for up to 25 additional meters
USB-A+A-5M	Improved Active USB 5 meter extension
VEXT-3/6/10/15/25/35/50/75/100	VGA extension through 100 feet

Where:

xx is the length of the cable in feet

MM indicates male-to-male connector

M is the length of the cable in meters

Cables can be purchased from Network Technologies Inc by calling 800-RGB-TECH (800-742-8324) or 330-562-7070.

TROUBLESHOOTING

Each and every piece of every product produced by Network Technologies Inc is 100% tested to exacting specifications. We make every effort to insure trouble-free installation and operation of our products. If problems are experienced while installing this product, please look over the troubleshooting chart below to see if perhaps we can answer any questions that arise. If the answer is not found in the chart, please check the FAQs (Frequently Asked Questions) at our website at <http://www.networktechinc.com> or contact us directly for help at 1-800-742-8324 (800-RGB-TECH) in US & Canada or 1-330-562-7070 worldwide. We will be happy to assist in any way we can.

Problem	Cause	Solution
No mouse or keyboard	<ul style="list-style-type: none"> Cable connections loose 	<ul style="list-style-type: none"> Check all cables for proper connection
No video	<ul style="list-style-type: none"> Loose video cable Power to monitor OFF 	<ul style="list-style-type: none"> Check video cable connection Make sure monitor is plugged into live outlet and powered ON
Mouse only moves up and down on computer(s) connected to the switch through a ST-C5USBV Extender	Driver communication not correct between mouse and CPU. Port set for non-MAC mode	Configure any CPU ports that have a ST-C5USBV connected for MAC Mode operation (see page 22)
Mouse not working properly or at all with SUN or PS/2 CPU connected	Driver communication not correct between mouse and CPU. Port set for MAC mode with a SUN or PS/2 CPU connected.	Configure ports correctly. Only MACs or ST-C5USBV Extender should be connected to port configured as MAC ports.

SPECIFICATIONS

Video Connectors	female 15HD-black
Video Resolution	1900 x 1200 (max.)
Video Support	SVGA, XGA, VGA, most DVI monitors (when used with NTI DVIF-15HDM adapter)
Video Bandwidth	150 Mhz
USER Keyboard/Mouse connectors	female USB Type A
Mouse and Keyboard Compatibility	most USB mice and keyboards
CPU connectors	female 15HD-yellow (high density)
CPUs supported	Windows USB, SUN USB, MAC USB
RS232 Connector	female RJ45
Power required	110 or 220 VAC @ 50-60 Hz at less than 25 watts.
Fuse Protection	2A, 240VAC
Regulatory approval	CE

INDEX

- Alternate command hot key, 26
- Apple Mouse, 29
- autologin, 27
- Autostatus, 34
- baud rate, 28, 31
- Broadcast Mode**, 18
- cables chart, 46
- Cascading**, 37
- Change password**, 24
- edit user, 23
- Find Mode, 16
- Firmware upgrade**, 40
- forgot password, 20
- front panel control, 11
- hot-plug, 4
- idle timeout, 25
- Installation**, 6
- Key Equivalents, 29
- keyboard control, 11
- limitations, 10
- Matrix Switcher's Control Program**, 34
- navigating OSD menus, 12
- OSD, 12
- Password and User Name, 20
- port configuration, 22
- Rack mounting**, 5
- reset port names, 26, 28
- RMTEST, 36
- RS232 Command Protocol, 33
- RS232 pinout, 31
- Scan Mode**, 17
- security configuration, 27
- security enable, 27
- Security features**, 12
- Select Language**, 26
- SerTest, 35
- Settings**, 15
- Sun's extra keys, 29
- system configuration, 22
- Troubleshoot**, 47
- usage statistics, 25
- USBVEXT-xx-MM cable, 8
- user access control, 24
- user configuration, 23
- user control methods, 11

WARRANTY INFORMATION

The warranty period on this product (parts and labor) is two (2) years from the date of purchase. Please contact Network Technologies Inc at **(800) 742-8324** (800-RGB-TECH) or **(330) 562-7070** or visit our website at <http://www.networktechinc.com> for information regarding repairs and/or returns. A return authorization number is required for all repairs/returns.

Man039 Rev 12/8/2008

Free Manuals Download Website

<http://myh66.com>

<http://usermanuals.us>

<http://www.somanuals.com>

<http://www.4manuals.cc>

<http://www.manual-lib.com>

<http://www.404manual.com>

<http://www.luxmanual.com>

<http://aubethermostatmanual.com>

Golf course search by state

<http://golfingnear.com>

Email search by domain

<http://emailbydomain.com>

Auto manuals search

<http://auto.somanuals.com>

TV manuals search

<http://tv.somanuals.com>