



# NILES®



## INSTALLATION GUIDE



**FOR USE IN MULTI-CHANNEL MUSIC OR HOME THEATER SYSTEMS**  
**HIGH DEFINITION, SIDE/REAR CHANNEL EFFECTS, IN-WALL LOUDSPEAKERS**

# HDFX

## CONGRATULATIONS!

Thank you for choosing **HDFX High-Definition, Side-/Rear-Channel Effects, In-Wall Loudspeakers** from Niles. With proper installation and operation, you should enjoy years of trouble-free use.

Niles manufactures the industry's most complete line of custom installation components and accessories for audio/video systems. To see the complete Niles product assortment, visit us on the Internet at: [www.nilesaudio.com](http://www.nilesaudio.com)

## TABLE OF CONTENTS

Introduction	1
Features and Benefits	1
Installation Considerations	3
Loudspeaker Placement	6
Installation Fundamentals	9
New Construction: Installing A Bracket	14
Existing Construction: Installing A Bracket	15
Finishing the Installation	17
Operation	22
Removing the Grille and Loudspeaker	22
Specifications	23

## INTRODUCTION

Niles HDFX High-Definition, Side-/Rear-Channel Effects, In-Wall Loudspeakers are expressly designed for superior sonic quality in side- or rear-channel applications. They employ advanced technology components that extract the subtle nuances in recorded music or the thunderous action sound in a movie. HDFX loudspeakers are the perfect choice wherever quality of sound is the most important consideration.

## FEATURES AND BENEFITS

### **5-1/4-INCH INJECTION-MOLDED TCC WOOFER WITH BUTYL-RUBBER SURROUND, LONG-THROW VOICE COIL/MAGNET STRUCTURE, AND VENTED POLE PIECE**

The HDFX features newly-developed woofer-cone material that combines injection-molded polypropylene with talc, carbon, and ceramic (TCC) stiffening agents. As a result, the cone offers extreme stiffness and light weight for accurate, dynamic response. A long-throw voice coil/magnet structure ensures increased cone excursion to enhance low frequency response and dynamic impact. Additionally, the woofer employs a vented pole piece for increased bass linearity and a butyl-rubber surround for improved midrange damping and clarity as well as moisture resistance.

### **DUAL 2-1/4-INCH INJECTION-MOLDED TCC FULL-RANGE DRIVERS FOR SIDE-CHANNEL EFFECTS**

Dual 2-1/4-inch injection-molded TCC™ (talc, carbon, and ceramic-filled) polypropylene full-range drivers fire to either side, providing a uniform, sound field that is ideal for special effects.

### **COAXIAL 1-INCH TETERON TRI-LAMINATE TWEETER WITH FLUID-COOLING AND ULTRA-WIDE DISPERSION FOR CLEAR AND DETAILED HIGH FREQUENCIES**

The HDFX's 1-inch Coaxial Teteron Tweeter employs a tri-laminate design consisting of an inner textile layer, which forms the dome, a high damping layer to kill unwanted resonances, and an outside layer of urethane to add stiffness and prevent breakup modes. The result is a transparently clear, sweet, natural-sounding tweeter, which still maintains extended frequency response.

### **INSTALLER-SELECTABLE ACOUSTIC FINE TUNING**

Using the baffle-mounted TREBLE/CUT and BASS/CUT controls, the installer can de-emphasize the bass and/or treble response by 3 dB after installing the HDFX to precisely tone match the sound in any room.

---

## **BIPOLE/DIPOLE AND FX/CUT SWITCHES**

The HDFX also includes a baffle-mounted BIPOLE/DIPOLE mode switch so the installer can set the surround effects for either side or rear placement. A companion FX/CUT switch allows adjustment of the direct/diffuse sound field balance to provide realistic effects, regardless of room size.

## **EASY RETROFIT INSTALLATION IN YOUR EXISTING HOME**

Designed for ease of installation, the Niles mounting system makes retrofit installations simple and fast. A supplied template assures fast and accurate hole cutting. The bracket slips behind the drywall, and the screws secure the bracket to the frame, sandwiching the drywall between them. The loudspeaker baffle attaches to the frame, and the grille mounts over the loudspeaker.

## **THREE-STAGE INSTALLATION SYSTEM FOR REMODELS OR NEW CONSTRUCTION**

Only the parts needed are installed during a particular stage of construction. After framing and wiring are finished, the bracket is installed. After the drywall is up, but before the painter begins to paint, the frame is installed, and the rustproof aluminum grille is left for the painter to match to the surroundings. The loudspeaker is installed only when construction is completely finished. Masking or prepping the loudspeaker for painting and worries about loudspeaker theft during final construction are never an issue!

## **MICROPERF™ ALUMINUM GRILLES**

Niles' exclusive MicroPerf™ aluminum-grille construction provides an exceptionally tight hole pattern for acoustic transparency at all audio frequencies and enables the loudspeaker elements to remain invisible. MicroPerf™ aluminum grilles can also be painted to blend seamlessly with the surrounding decor.

## **NILES' HD HIGH-DEFINITION VOICE MATCHING**

Ensures compatibility with other Niles HD High-Definition in-wall, on-wall, and ceiling-mount models to accommodate a wide range of system designs.

## **DOLBY® DIGITAL READY**

The HDFX is specifically designed for Home Theater Sound. This model exceeds the specifications set forth by Dolby Laboratories for the accurate reproduction of Dolby Digital-Encoded Sources.

## INSTALLATION CONSIDERATIONS

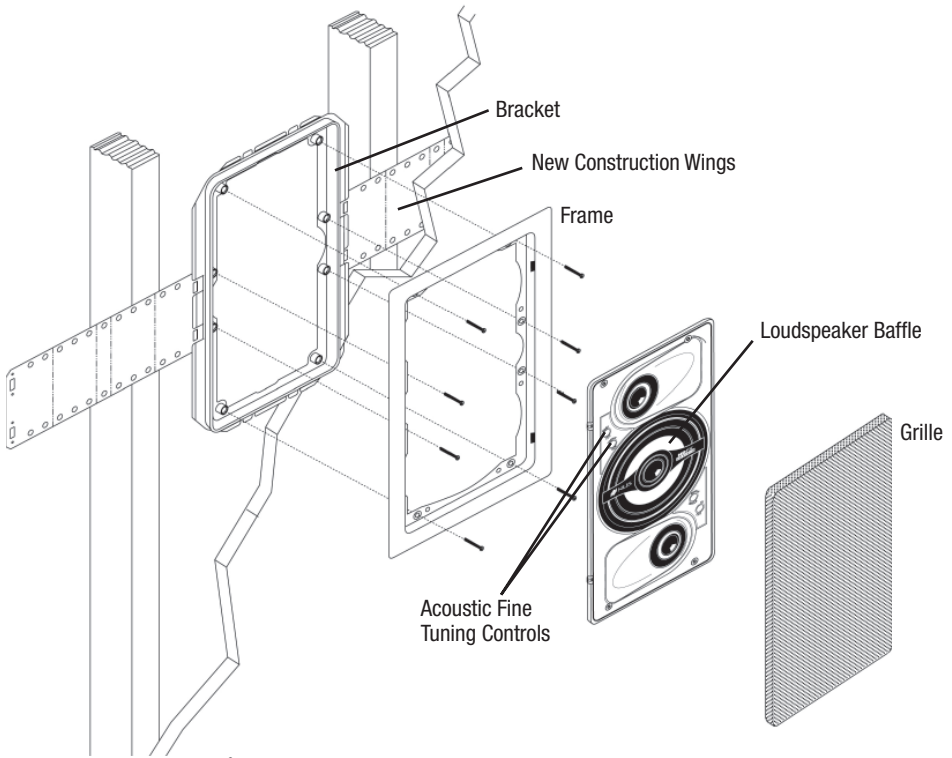

**Figure 1.** Mounting an HDFX vertically into a wall

## TOOLS AND PRECAUTIONS

We recommend using the following tools to install an HDFX loudspeaker:

- *Electric drill with 1/4- and 1/2-inch drill bits, and a 1-inch flat drill bit (for drilling through studs)*
- *Keyhole or drywall saw*
- *Stiff wire, fish tape, or glow rods (for routing cables)*
- *Phillips screwdriver set*
- *Cable ties*
- *Pencil*
- *Level*
- *Rubber gloves and protective eyewear*

Before starting the installation, please observe the following precautions:

- *Turn off all system power before making any connections.*
- *Always wear protective eyewear when using tools.*
- *Make sure hands are clean before installation.*
- *Wear gloves when working with fiberglass insulation.*

## RECOMMENDED AMPLIFIER POWER

For satisfactory performance, we recommend using a surround amplifier with a power rating of 10 to 150 watts. Curiously, most loudspeakers are not damaged by large amplifiers, but rather by small amplifiers. If your system is playing loud music, a small amplifier will run out of power very quickly and can create damaging “clipping” distortions. A more powerful amplifier will play at the same volume without distorting. See **OPERATION** on page 22 for more information about amplifier clipping distortion.

## LOUDSPEAKER WIRE

Use 2-conductor loudspeaker wire when connecting loudspeakers to your receiver or amplifier. For most applications, we recommend using 16- or 18-gauge wire. For wiring runs longer than 80 feet, we recommend 14-gauge wire. The spring-loaded terminals of the HDFX will accommodate up to 12-gauge wire directly. Larger sizes can be accommodated via pin connectors.

When running wire inside walls or ceilings, use special jacketed cable (CL-2 or CL-3) to protect the wire and for fire prevention. In some areas, conduit is also required. For a trouble-free installation, low-voltage wire such as loudspeaker wire must be run in accordance with the National Electrical Code and any applicable provisions of the local building code. If you are unsure of the correct installation techniques, wire jacket, or type of conduit to use, consult a professional audio/video installer, building contractor, or the local building and inspection department.

## INSULATING THE WALL CAVITY

For best performance from your loudspeakers, fill the wall cavity behind the loudspeaker with fiberglass insulation (e.g., R-19 unfaced insulation). Try to keep the same amount of insulation for each loudspeaker, particularly in the same room, for consistent bass response.

### TECH TIP

Wire size is expressed by its AWG (American Wire Gauge) number – the lower the number, the larger the wire. For example, 12 AWG is physically larger than 14 AWG.

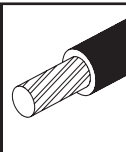

## LOUDSPEAKER PLACEMENT

NOTE: THE NILES HDFX LOUDSPEAKER IS DESIGNED FOR USE IN SIDE- OR REAR-CHANNEL APPLICATIONS ONLY. FOR FRONT-OR CENTER-CHANNEL APPLICATIONS, WE RECOMMEND USING A NILES HDLCR OR HDLCR<sub>BX</sub> LOUDSPEAKER

### PLACEMENT FOR HOME THEATER REAR APPLICATIONS

In home theater, the goal is to reproduce the experience of a great movie theater in your home. The biggest difference between the two venues is the use of a rear- or surround-loudspeaker array in a commercial theater. Here, it is not uncommon to see 20 or 30 loudspeakers placed around theater walls. This huge array of loudspeakers assures the audience will feel completely surrounded by the ambient soundtrack of the movie.

Filmmakers carefully use the “surround” soundtrack to envelope viewers in the sound environment on screen. They will place background music, rain sounds, traffic noise, etc. on the “surround” soundtrack to create desired effects. However, in a home with a single pair of front loudspeakers, this surround effect will be lost, and jungle sounds may actually sound like they are emanating “from the middle of your head,” just like headphones!

Each HDFX loudspeaker is equipped with a BIPOLE/DIPOLE switch that optimizes the surround effects for either side or rear placement (see **SETTING THE BIPOLE/DIPOLE MODE** on page 20). Here are some recommended loudspeaker placement tips:

- *Place the surround loudspeakers on a rear wall directly behind the listening position. If possible, try placing the loudspeakers nearer to the corners, as shown in **Figure 2** and **3**. Set each BIPOLE/DIPOLE switch to DIPOLE for reflected sound. Moreover, the adjoining walls will act as powerful reflectors to create even more reflections.*
- *If you place the surround loudspeakers farther away from the listener, the surround sound will dissipate, requiring even more power from the surround-sound channels. If your sound system uses a small 5- or 10-watt surround amplifier for the rear loudspeakers, be sure to place the loudspeakers within 5 to 8 feet of the listening location.*
- *If you are using a larger 25- to 50-watt surround amplifier, you can mount the loudspeakers 10 to 15 feet away from the listening location and still achieve reasonably high volume levels. In large or unusually-shaped rooms, this might be the only way to achieve a good effect.*



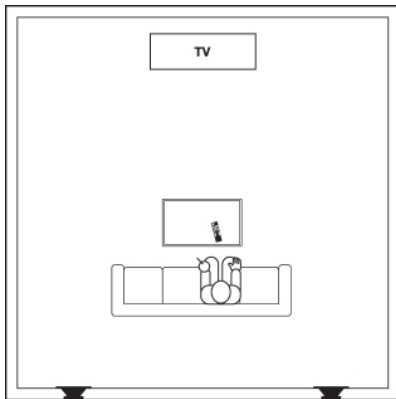

**Figure 2.** HDFX loudspeakers are placed near back corner walls of a home theater room.

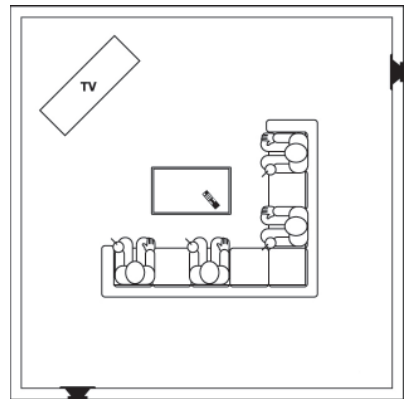

**Figure 3.** HDFX loudspeakers are placed near back corner walls of a home theater room with an L-shaped sofa.

- *If your home theater system is capable of reproducing Dolby EX surround sound, consider using a second pair of HDFX loudspeakers (on the side walls) for an additional rear surround effect, as shown in **Figure 4** (on the next page). Ideally, the side loudspeakers should be placed in-line with the listening position with the BIPOLE/DIPOLE controls set to DIPOLE. For a more focused surround effect, set the BIPOLE/DIPOLE controls to BIPOLE.*
- *If you like listening to music in surround modes (which emulate concert hall acoustics), consider using more than two surround loudspeakers to provide an extraordinary effect. With Niles HDFX loudspeakers, it is easy to add another pair without affecting the decor of the room.*

NOTE: FOR THIS APPLICATION, YOU WILL NEED TO USE A MORE POWERFUL AMPLIFIER THAN THE ONE BUILT INTO A TYPICAL SURROUND-SOUND RECEIVER OR AMPLIFIER. NILES MAKES A NUMBER OF SYSTEMS INTEGRATION AMPLIFIERS WITH PROPRIETARY FEATURES THAT MAKE THEM UNIQUELY SUITED TO ENHANCE YOUR EXISTING SURROUND-SOUND SYSTEM. CONSULT YOUR LOCAL NILES DEALER FOR MORE INFORMATION.

(CONTINUED ON NEXT PAGE)

## PLACEMENT FOR HOME THEATER REAR APPLICATIONS (CONTINUED)

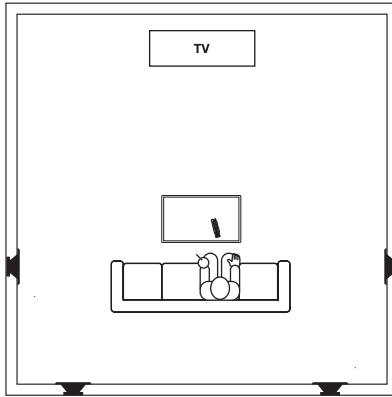

**Figure 4.** Two pairs of HDFX loudspeakers reproduce Dolby EX surround sound in a home theater room.

### THE BOUNDARY EFFECT

Placing a loudspeaker in a corner can powerfully affect the way a listener perceives bass response. Known as the boundary effect, placing loudspeakers close to a wall/ceiling boundary or near a corner-wall boundary will emphasize certain bass frequencies, while canceling others. This effect can make the loudspeaker sound excessively boomy and inaccurate to some listeners, while to others it just seems like more bass sound.

As a good rule-of-thumb, if you like listening to your current pair of loudspeakers with the bass turned up, you'll enjoy corner placement. However, if you listen with the tone controls at neutral, try keeping the loudspeakers at least 2 or 3 feet from the boundaries of the room.

## INSTALLATION FUNDAMENTALS

### RUNNING THE LOUDSPEAKER WIRE IN NEW CONSTRUCTION

**IMPORTANT: IF YOU HAVE DOUBTS ABOUT WHETHER YOU ARE CAPABLE OF INSTALLING A NILES WALL-MOUNT LOUDSPEAKER, PLEASE CONSULT A NILES DEALER OR PROFESSIONAL INSTALLER. THEY HAVE SPECIAL TOOLS, TECHNIQUES, AND EXPERIENCE TO MAKE THE IMPOSSIBLE JOB POSSIBLE. THE INSTALLER CAN PROVIDE YOU WITH AN ESTIMATE BEFORE ANY WORK IS DONE.**

#### OBSERVE SAFETY FIRST!

- *Always wear gloves, safety goggles, and head protection gear when drilling or cutting holes.*
- *Avoid drilling near nails – they ruin bits and can cause injury.*
- *Be careful using “hole-hogs” and other powerful electric drills. The torque of this drill when suddenly stopped by a nail can break the wrist of a strong man.*

#### SCHEDULING AND PREPARATION

Plan to schedule the loudspeaker wiring after the electrical wiring is finished. That way you can avoid wire routes, which could potentially induce hum over the loudspeaker wire. The basic wiring rules are:

- *Never run loudspeaker wire through the same hole as an electrical cable.*
- *Never run loudspeaker wire into the same J-box as electrical cable.*
- *Avoid running the loudspeaker wire beside the electrical cable. Keep your loudspeaker cable at a distance of at least 3 feet from any electrical power cable.*
- *If side-by-side wiring is unavoidable in particular spots in the house, move the loudspeaker wire route away as soon as possible.*
- *If construction forces a side-by-side run for more than 10 feet, install metal conduit or shielded loudspeaker wire. Low-voltage wires such as doorbells, intercoms, telephone, security, or television cannot cause interference or hum on your loudspeaker wires, so you can safely run all of them at the same time, through the same holes, side-by-side.*
- *Before drilling any holes, mount the loudspeaker brackets in the desired loudspeaker locations and mount p-rings or open-backed J-boxes where the in-wall volume controls and stereo equipment will be located.*

(CONTINUED ON NEXT PAGE)

# RUNNING THE LOUDSPEAKER WIRE IN NEW CONSTRUCTION (CONTINUED)

## ABOUT DRILLING

Use a bit that is large enough for the wires you plan to run. This is an important consideration, since you may be drilling a lot of holes. Here are some additional tips:

- *We recommend using an auger bit for rough-in wiring. It will actually pull itself through the wood, so that the drill motor, not you, does most of the work.*
- *Always drill the holes in the center of the stud. If you have to notch the stud or drill the hole closer than 1 inch from the edge of the stud, protect the wire with a nail plate, as shown in **Figure 5**.*
- *When drilling holes in ceiling joists, drill in the center of the joists and try to locate the hole near the end of the joist.*

**IMPORTANT: DO NOT DRILL THROUGH A GIVE-LAM OR LOAD-BEARING BEAM WITHOUT THE DIRECTION OF YOUR CONTRACTOR.**

- *Try to line the holes up perfectly, because it makes pulling the wire much easier. A good technique is to snap a chalk line across the face of the studs or against the bottom of the ceiling joists. Then work backward so that you can always see the holes you have already drilled. Paying careful attention to this will save you time later on.*

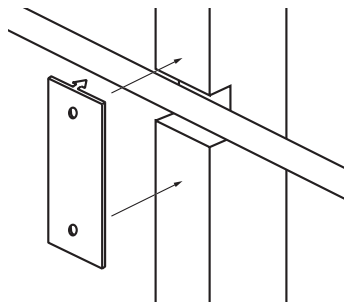

**Figure 5.** Installing a nail plate to protect wiring in a notched stud.

## PULLING THE CABLE

Pull the cable in sections (from the stereo to the volume control, from the volume control to the loudspeaker). Start with the longest sections and use leftover wire to complete the short sections. Also consider the following wiring tips:

- *If you plan to pull many rooms at the same time through a central route, walk off the distance to each destination, add a generous “fudge factor” for turns and other obstacles, and then cut off each section, so you can pull a bundle of wires at once.*
- *When running the wire further than 4-1/2 feet from a hole in a stud or joist (e.g., open attic space, going up walls, etc.), be sure to fasten the wire to the joists or studs using cable clamps or appropriately-sized wire staples. The wire should not have large sags in it, nor should it be too tight.*
- *Try to protect the wire from being stepped on in attics or other unfinished crawl spaces. Use guard strips, raceways, or conduits to protect the cable. Consult the local building code for special requirements in your area.*

# CONCEALING LOUDSPEAKER WIRE

## ABOUT INTERIOR WALLS

Interior walls in almost all North American residences are hollow, so they are easy installation sites for flush mounting loudspeakers and routing new loudspeaker cable in the house. Looking at a painted wallboard, plaster, or paneling, you only see the skin of the wall. Behind it is the home's skeleton; 2-by-4 inch wood or metal "studs" running vertically from the floor to the ceiling in walls and 2-by-6 inch or larger "joists" running horizontally in the ceilings and floors. The space between the studs and joists is used for the home's wiring and plumbing.

## ABOUT EXTERIOR WALLS

Concealing wires in exterior walls is more complex, since the walls are stuffed with insulation to protect the house from the heat and cold outside. Moreover, our national building code requires that a horizontal stud placed between the vertical studs break the hollow wall space in exterior walls. This "fire blocking" makes it very difficult to retrofit long lengths of wire. In some areas of the country, the exterior walls are constructed of solid masonry and have no hollow space for loudspeakers or wires.

## PLANNING THE LOUDSPEAKER WIRE ROUTE

Start by examining all the possible routes you might take to run the loudspeaker wire from the loudspeaker to the home theater system. Use a stud sensor or other device to locate the internal structure of the wall. You will want to avoid all studs or joists. **Figure 6** shows a typical wire run from the loudspeaker location in the wall, across the attic, then down through a top plate (i.e., the horizontal 2-by-4 or 2-by-6 inch wood laid across the vertical studs) to a wall plate or a J-Box in the wall behind the home theater system itself.

Find all the locations of your existing electrical, phone, and TV wiring, and then plan the loudspeaker wire route to avoid them. Crossing wire paths is acceptable, but 60 Hz hum may be induced in the reproduced audio if loudspeaker wire is run parallel to electrical wire for more than a few feet. If possible, try to keep loudspeaker wire away from parallel power cables by at least 3 feet.

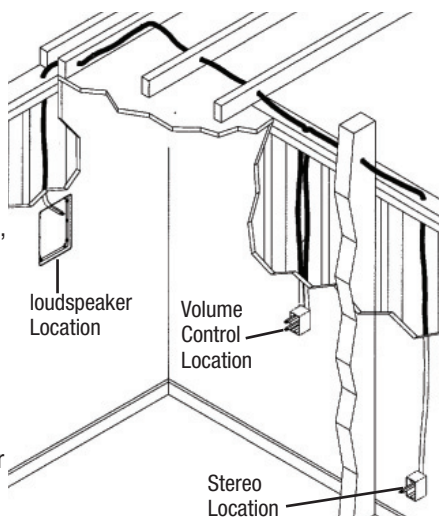

**Figure 6.** Running loudspeaker wire from a wall loudspeaker to a home theater system location.

(CONTINUED ON NEXT PAGE)

## CONCEALING LOUDSPEAKER WIRE (CONTINUED)

### PLANNING THE LOUDSPEAKER WIRE ROUTE (CONTINUED)

To find exactly where an electrical cable is routed, try inspecting the inside of the wall by turning off the breaker for a particular power outlet or switch, removing the cover plate and switch or receptacle, and then shining a penlight into the wall. If you have access to an attic or base-ment space, you can quickly see which part of the wall space is free of obstructions, as shown in **Figure 7**.

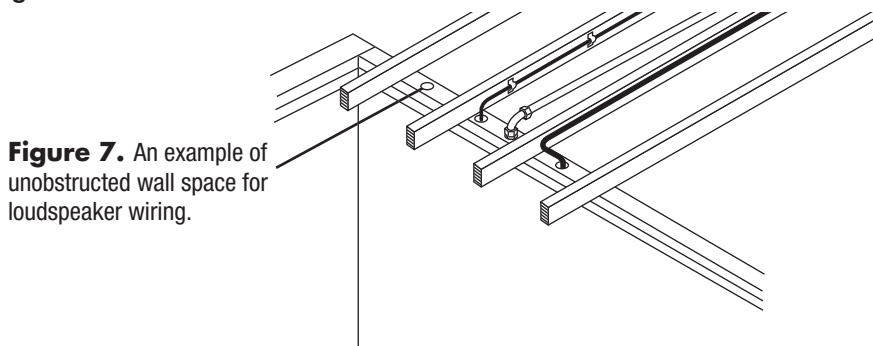

**Figure 7.** An example of unobstructed wall space for loudspeaker wiring.

When you don't have access above or below the wall, try to estimate the existing wire and pipe locations from known positions of electrical outlets and plumbed fixtures on both sides of the wall. Take a look at the outside of your house too – sometimes conduit, vents, or drainpipe will provide useful visible clues. Choose the route with the fewest potential obstacles.

If the home is built on a slab, or a loudspeaker wire route is planned between two finished floors, look for baseboards that could be removed for wire placement. Doorjamb can also be removed and often have enough space for loudspeaker wire all the way around the door, as shown in **Figure 8**.

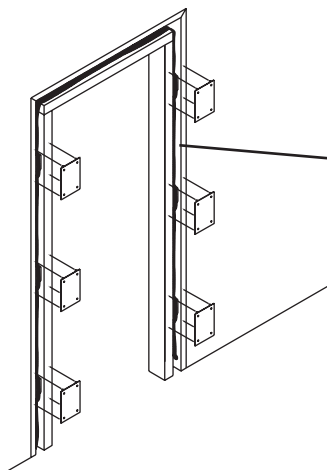

**Figure 8.** Running loudspeaker wire between a wall and a removed doorjamb. Nail plates are also installed to protect the wire when the doorjamb is replaced.

## OTHER POSSIBLE LOUDSPEAKER WIRE ROUTES INCLUDE:

- *Under-the-carpet runs using flat loudspeaker wires.*
- *Heating and air conditioning vents used as wire raceways for plenum-rated wire.*

NOTE: CHECK YOUR LOCAL BUILDING CODES, SINCE SOME MUNICIPALITIES REQUIRE CONDUIT.

## CUTTING HOLES

In traditional wood stud/drywall construction, first cut the hole for the loudspeaker. Then, in the opening, use a drill with a long bit to auger a wire route up or down the wall. Next, cut a hole in the drywall for stud access, drill holes through the studs, and run your wire, as shown in **Figure 9**.

After the wire has been run, patch the hole with the cut drywall using standard drywall joint tape and joint compound. Let the patch dry, sand the surface, and touch-up the wall with paint.

NOTE: BE PATIENT WITH UNKNOWN STRUCTURES OR DIFFICULT-TO-PATCH WALL MATERIALS LIKE PLASTER, LATH AND PLASTER, FAUX FINISHES, WALLPAPER ETC. ALWAYS PERFORM A CAREFUL STUDY OF THE POTENTIAL PROBLEMS BEFORE STARTING THE JOB.

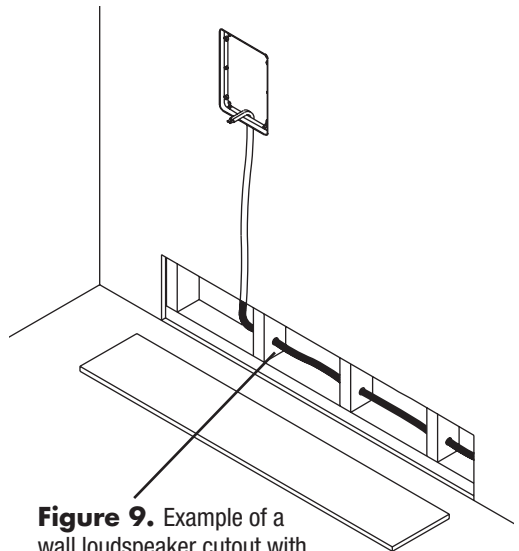

**Figure 9.** Example of a wall loudspeaker cutout with studs drilled for wire run.

(CONTINUED ON NEXT PAGE)

## NEW CONSTRUCTION: INSTALLING A BRACKET

The hole-saving bracket enables a faster and cleaner final installation of the loudspeaker. It forces the drywall installer to cut out the loudspeaker hole for you and provides wire ties for the loudspeaker wire, reducing the risks of accidental loss or movement of the wire. In addition, it enables you to align your loudspeakers with other ceiling fixtures with greater accuracy, since you can see exactly where the loudspeaker will be.

### INSTALLING THE BRACKET

1. Attach the QuickSnap™ new-construction wings to the bracket by snapping them into the bracket sides, as shown in **Figure 10**. If the length will interfere with corner or eaves, shorten the wings by breaking them along the scored lines.

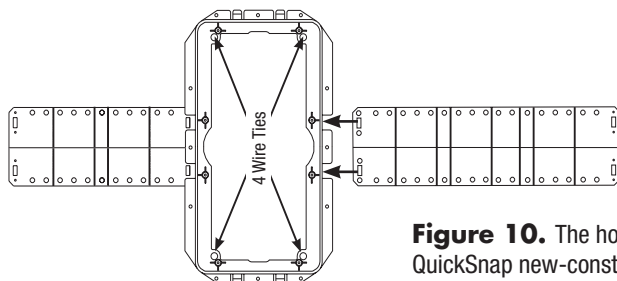

**Figure 10.** The hole-saving brackets include QuickSnap new-construction wings.

2. Screw one side of the assembled bracket with wings to the stud or joist, using one of the supplied screws. Level the bracket, and then screw the other side of the bracket/wing assembly to the stud or joist. Two screws on each side make for a very secure installation.
3. Attach the wire to the bracket at the indicated wire tie points, as shown in **Figure 11**.

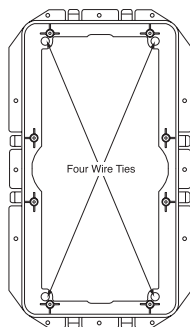

**Figure 11.** The brackets have four wire-tie points.



## CONCEALING LOUDSPEAKER WIRE FOR A FUTURE INSTALLATION

1. *Attach the loudspeaker wire in a loop between the wall studs or ceiling joists and carefully mark the exact location of the wire on a set of plans.*
2. *Ask the general contractor to inform the drywall installers that the loudspeaker wire loops are concealed for future installations, as shown in **Figure 12**.*

**Figure 12.** The loudspeaker wire is looped and hung on two nails attached to the joists, securing it for future use. Be sure to note the location on house plans.

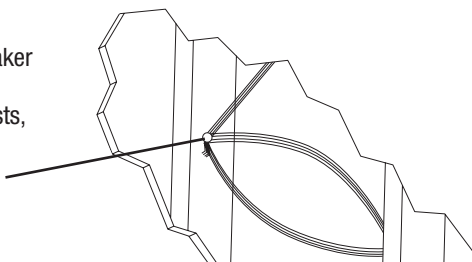

### EXISTING CONSTRUCTION: INSTALLING A BRACKET

**IMPORTANT: BEFORE YOU CUT INTO ANY WALL, REVIEW THE SECTIONS ON RUNNING WIRE AND LOUDSPEAKER PLACEMENT STARTING ON PAGE 6. BE SURE NOT TO DRILL OR CUT THROUGH EXISTING WIRES, PIPES, OR STRUCTURE. IF YOU FEEL ANY EXTRA RESISTANCE AS YOU ARE DRILLING OR SAWING, STOP!**

1. *Locate studs or joists by using a stud sensor or by hand knocking. Do not place the edge of the cutout directly next to a stud or joist, since the frame and bracket will extend beyond the cutout.*
2. *At the planned cutout site, drill a 1/8-inch pilot hole just barely through the wall, about an inch below the center of your proposed loudspeaker location.*

NOTE: IN MOST HOMES, THE WALL THICKNESS IS 1/2 TO 5/8 INCH.

3. *Cut a foot-long piece of coat hanger and bend it to create a right angle. Poke the "L-shaped" wire into the pilot hole and turn it in a complete circle, as shown in **Figure 13**.*

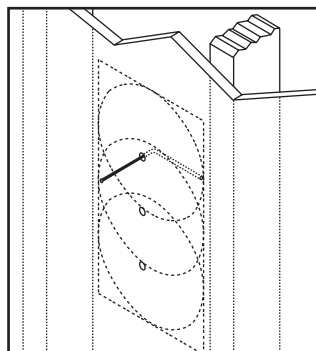

**Figure 13.** Using a coat hanger to check for obstructions behind the wall loudspeaker site.

(CONTINUED ON NEXT PAGE)

## EXISTING CONSTRUCTION: INSTALLING A BRACKET (CONTINUED)

4. *Continue turning the coat hanger as you move it into the cavity to a depth of approximately 4 inches. If you feel an obstruction, fill the hole(s) with spackling compound and repeat steps 1 through 4 at a new location.*
5. *If the coat hanger moves freely in a complete circle, hold the supplied template up to the wall or ceiling and level it in the horizontal or vertical position. Use a pencil to outline the cutout on the surface and then drill the four corner holes with a 1/4-inch bit (see **Figure 14** on page 17).*
6. *If you are cutting drywall, use a sheetrock or keyhole saw. Cut the outline with the saw at a 45-degree angle. That way, the drywall section can be replaced cleanly if there is an unseen obstruction behind the wall.*
7. *If you are cutting into a plaster ceiling, use masking tape to outline the penciled opening and use a razor to score the plaster down to the lath beneath. Then use a chisel to remove all of the plaster within the taped outline. To actually cut the lath, consider the following two professional methods:*
  - *Use a saber saw with a metal cutting blade for the quickest cut. However, sawing lath with a saber saw can easily vibrate plaster off the ceiling in a completely distant location, thereby creating more patchwork.*
  - *If you have the patience, use a pair of tin snips to slowly nip away at the lath instead. There is little risk with this method – it is just more time consuming.*

## FINISHING THE INSTALLATION

### PAINTING THE GRILLE AND FRAME

After drywall is up, each HDFX frame and grille may be painted without the need for primer. For best results, use a spray gun or airless sprayer, thin the paint to prevent clogging of the grille holes, and apply several light coats instead of one heavy one.

1. *Paint each grille and let it dry before installation.*
2. *Paint each frame and let it dry before installation.*

### INSTALLING THE FRAME

1. *Fill each wall cavity with insulation. Remember to use equal amounts of insulation for each loudspeaker.*
2. *For existing construction, slip the mounting bracket through the hole and pull it toward you so that its front edge slides into the hole and stops in place.*

NOTE: FOR NEW CONSTRUCTION, THE MOUNTING BRACKET SHOULD ALREADY BE IN PLACE (AS DESCRIBED IN THE SECTION **NEW CONSTRUCTION: INSTALLING A BRACKET** ON PAGE 14.

3. *Attach each frame to its bracket using the supplied screws, as shown in **Figure 14**. The screws should pull the frame and bracket together (sandwiching the drywall) so that the frame is absolutely flush with the wall surface. There should be no gaps between the wall and the frame.*

**IMPORTANT: DO NOT OVER TIGHTEN THE SCREWS! OVER TIGHTENING THEM MAY MAKE THE GRILLE DIFFICULT TO INSTALL.**

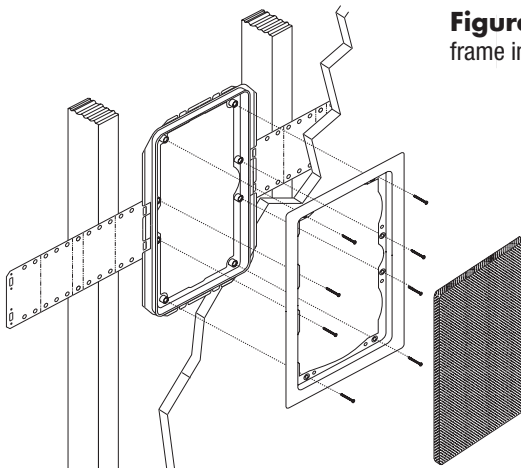
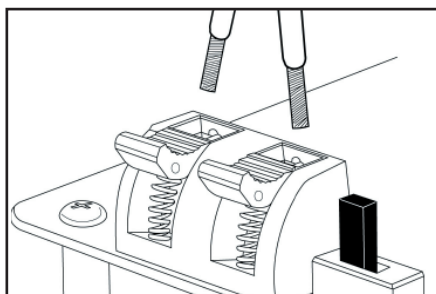

**Figure 14.** Installing the frame into a mounting bracket.

## CONNECTING AND INSTALLING THE LOUDSPEAKER

1. At each loudspeaker, separate the loudspeaker wire so that at least 2 inches of each conductor are free. Strip away 1/4 inch of insulation from each loudspeaker wire.
2. On each set of loudspeaker connectors, press down the spring-loaded lever, insert the appropriate conductor, and then release the lever, as shown in **Figure 15**. Gently tug on the loudspeaker wire to make sure it is held in place. If not, repeat this procedure until it is.

NOTE: OBSERVE CORRECT POLARITY: POSITIVE (+) GOES INTO THE RED TERMINAL AND NEGATIVE (-) GOES INTO THE BLACK TERMINAL.

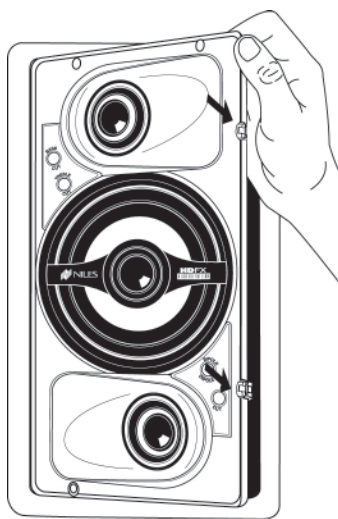

**Figure 15.** Connecting a loudspeaker wire to the HDFX terminals.

3. Connect the other end of each loudspeaker wire to the receiver (or amplifier) in the same way. If you are unsure of wire polarity, see the next section, **Checking Loudspeaker Phase** on page 19.

NOTE: OBSERVE CORRECT POLARITY: POSITIVE (+) GOES INTO THE RED TERMINAL AND NEGATIVE (-) GOES INTO THE BLACK TERMINAL.

4. Install the loudspeaker baffle into its frame by inserting the tabs at the base into the corresponding holes in the frame and pushing the loudspeaker forward until the snaps engage, as shown in **Figure 16**.



**Figure 16.** Installing the loudspeaker baffle into its frame.

**IMPORTANT: WHEN INSTALLING THE LOUDSPEAKERS IN THE CEILING, OR IF THE INSTALLATION IS IN AN EARTHQUAKE ZONE, WE RECOMMEND USING THE ENCLOSED SHEET METAL SCREWS TO SECURE THE BAFFLE TO THE FRAME AS FOLLOWS:**

- a. *Locate the dimples on the front baffle.*
- b. *Place the self-tapping sheet-metal screw in the dimple and turn it with a screwdriver until it cuts through the baffle and anchors securely in the frame, as shown in **Figure 17**.*

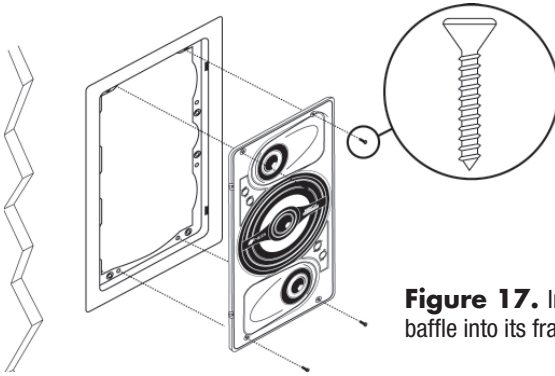

**Figure 17.** Inserting the loudspeaker baffle into its frame with sheet-metal screws.

5. *Turn on the home theater receiver and calibrate all loudspeakers in the system according to the receiver manufacturer's instructions.*

## CHECKING LOUDSPEAKER PHASE

*Loudspeaker wire has two conductors. On both your loudspeaker and amplifier, one conductor is attached to the negative (-) terminals, while the other is attached to the positive (+) terminals. Usually, the wire is marked for your convenience, but the marking can be done in the following different ways:*

- *Stripe on one wire*
- *Ribbed area you can feel on one conductor*
- *Different colors of metal wire on each conductor*
- *Fabric strand or string wound into one of the conductors*

(CONTINUED ON NEXT PAGE)

## CHECKING LOUDSPEAKER PHASE (CONTINUED)

Of course, there are some wires that appear completely identical. So be careful, or you might make a connection mistake. If you do, one loudspeaker will be playing “out-of-phase” with the other loudspeaker. A pair of out-of-phase loudspeakers works against each other, and the sound of the two playing together will be lacking in bass and sound “phasey.” If you suspect the sound is not right, and you cannot see any markings on the wire, try this simple test:

1. *Stand halfway between the loudspeakers.*
2. *Play some music with the amplifier or radio set to Mono.*
3. *Listen to the richness of the bass and the loudness of the sound.*
4. *Turn off the amplifier and reverse the connections on one amplifier channel only.*
5. *Repeat the listening test with the same volume control setting. When the sound has a richer bass and is slightly louder, the loudspeakers are working together or “in-phase.”*

## SETTING THE BIPOLE/DIPOLE MODE

Set the BIPOLE/DIPOLE switch on each HDFX according to the loudspeaker’s side or rear placement, as shown in **Figure 18** (on the next page). Here are some tips on usage:

- *Use the DIPOLE setting on rear loudspeakers when listening to movies and classical music. The sound will be less focused as it is reflected along the room’s boundaries. This is the best choice, since most films are mixed using non-localized surround effects, and classical music is usually recorded in a favorable acoustic environment.*
- *Use the BIPOLE setting on rear loudspeakers when listening to discrete multichannel recordings that equally emphasize front and surround sounds.*
- *For multiple sets of HDFX loudspeakers, use the BIPOLE setting on the side loudspeakers (aimed at the listening position) for a more focused surround effect. For the rear loudspeakers, use the DIPOLE setting to diffuse the sound.*

## SETTING THE DIRECT/DIFFUSE SOUND FIELD BALANCE

Each HDFX also includes a companion FX/CUT control (see **Figure 18**) that allows adjustment of the direct/diffuse sound field balance to provide realistic effects regardless of room size.

- *In large rooms (where the loudspeakers are farther away from the listening position), use the FX setting for a more direct sound.*
- *In small rooms, use the CUT setting for a more diffuse sound.*

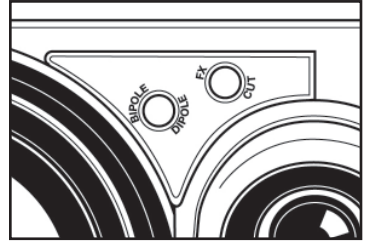
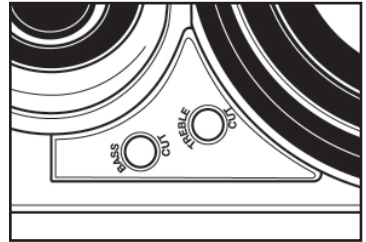

**Figure 18.** The HDFX includes BIPOLE/DIPOLE and FX/CUT controls.

## ACOUSTIC FINE TUNING

Each HDFX loudspeaker features separate, baffle-mounted TREBLE/CUT and BASS/CUT controls for acoustic fine-tuning after installation, as shown in **Figure 19**.

- *If an HDFX is placed near a boundary, use the CUT setting to lower the bass response by 3 dB.*
- *If an HDFX is placed in a room with highly reflective surfaces like glass or tile, use the CUT setting to lower the high-frequency response by 3 dB.*



**Figure 19.** The HDFX features TREBLE/CUT and BASS/CUT controls.

## INSTALLING THE GRILLE

At each loudspeaker, carefully fit the grille into its recess so that it is barely in place. Starting with one corner, gently press the grille around the loudspeaker, pushing it in a little bit each time. Be gentle – the aluminum grille can be easily bent out of shape. When properly installed, the grille will be absolutely flush in appearance with the surrounding frame.

## OPERATION

### LISTENING AT HIGHER VOLUMES

Achieving a reasonable volume of sound in a large room requires more amplifier power than it does in a small room. It is possible to turn the volume up so high that the amplifier runs out of power. This creates “clipping” distortion, which will make treble sound very harsh and unmusical.

When you hear harsh-sounding treble from any good loudspeaker, turn the volume down immediately! Those harsh sounds are masking much more powerful ultra-high-frequency sound spikes, which will quickly damage any fine loudspeaker. You are much less likely to damage a loudspeaker driven by a large amplifier because it will be very loud before any clipping distortion is produced.

### CLEANING

Clean the Niles HDFX loudspeaker with a dampened soft cloth or paper towel. If the loudspeaker is mounted high up on a wall or ceiling, use a broom to gently brush it off.

## REMOVING THE GRILLE AND LOUDSPEAKER

### REMOVING THE GRILLE

If you need to remove an installed grille, use a bent paper clip or the tip of a corkscrew to gently pull it away from the frame.

### REMOVING THE LOUDSPEAKER

After removing the grille, use two small screwdrivers (or needle-nose pliers) to release the snaps that hold the loudspeaker (and baffle) to the frame. Insert the screwdrivers into the holes in the snaps and exert force straight down (towards the woofer) until the snaps release, as shown in **Figure 20**.

Once the snaps release, the loudspeaker can be tilted away from the frame to be removed.

**NOTE: DO NOT ATTEMPT TO USE THE FRAME FOR LEVERAGE, AS THIS MAY DAMAGE THE SURFACE OF THE FRAME.**

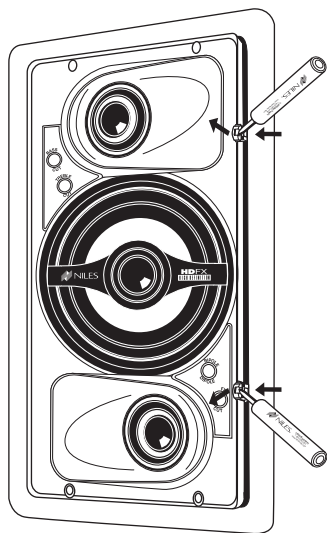

**Figure 20.** Removing the HDFX loudspeaker baffle from its frame.



## SPECIFICATIONS

### Recommended Amplifier Power

10 to 150 watts per channel

### Frequency Response

65 Hz to 21 kHz, +/- 3 dB

### Frame Dimensions

8-1/4" x 14-1/2"  
(21.0 cm x 36.8 cm)

### Depth Behind Wall

3-1/2" (based on 1/2" drywall)  
(8.9 cm)

### Wiring Requirements

We recommend using 16- to 18-gauge loudspeaker wire for runs up to 80 feet and 14-gauge loudspeaker wire for runs up to 200 feet. The connectors will accommodate 12- to 22-gauge wire.

### Nominal Impedance

8 ohm

### Sensitivity

88 dB with 2.83 V pink noise input,  
measured at 1 meter on axis

### Hole Cut-Out Dimensions

7-1/8" x 13-1/4"  
(18.1 cm x 33.7 cm)







BLENDING HIGH FIDELITY AND ARCHITECTURE®

Niles Audio Corporation  
12331 S.W. 130 Street Miami, Florida 33186  
Designed and Engineered in USA

1-800-BUY-HIFI or 305-238-4373

©2008 Niles Audio Corporation. All rights reserved. Niles, the Niles logos and Architecture are registered trademarks of Niles Audio Corporation. MicroPerf and TCC are trademarks of Niles Audio Corporation. All other trademarks are the property of their respective owners. DS00421B  
Download from [www.Somanuals.com](http://www.Somanuals.com). All Manuals Search And Download.

## Free Manuals Download Website

<http://myh66.com>

<http://usermanuals.us>

<http://www.somanuals.com>

<http://www.4manuals.cc>

<http://www.manual-lib.com>

<http://www.404manual.com>

<http://www.luxmanual.com>

<http://aubethermostatmanual.com>

Golf course search by state

<http://golfingnear.com>

Email search by domain

<http://emailbydomain.com>

Auto manuals search

<http://auto.somanuals.com>

TV manuals search

<http://tv.somanuals.com>