

M O D E L
OS-25

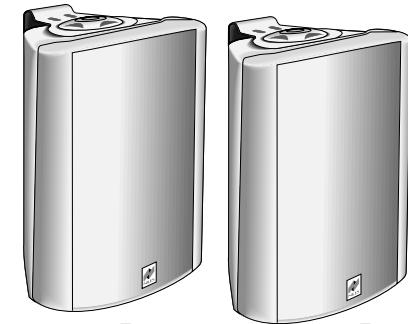

Indoor/Outdoor Loudspeaker.



NILES®

Niles Audio
Corporation

12331 S.W. 130 Street
Miami, Florida 33186
Tel: (305) 238-4373
Fax: (305) 238-0185

Printed in Taiwan



NILES®

CONGRATULATIONS

Thank you for choosing the **OS-25 Indoor/Outdoor Loudspeaker** from Niles. With proper installation and operation, you'll enjoy years of trouble-free use.

Niles manufactures the industry's most complete line of custom installation components and accessories for audio/video systems. For a free full line catalog write: **Niles, Catalog Request, P.O. Box 160818, Miami, Florida 33116-0818**

TABLE OF CONTENTS

INTRODUCTION	2
FEATURES & BENEFITS	3
PARTS GUIDE	6
INSTALLATION CONSIDERATIONS	7
PAINTING THE OS-25	12
INSTALLATION	15
OPERATION	18
SPECIFICATIONS	19
WARRANTY REGISTRATION CARD	21
LIMITED WARRANTY	22

INTRODUCTION

The **OS-25** marries unparalleled listening satisfaction with the freedom to listen to music anywhere! You can use them indoors and outdoors (even on a boat). The extraordinary sonic performance of the **OS-25** was achieved by harmonizing unique and proprietary technology with the most advanced manufacturing methods and materials available.

The **OS-25** is a two-way speaker in an acoustic suspension enclosure. The cabinet is shaped to fit neatly into corners or eaves. It is supplied with a swiveling mounting bracket for easy installation anywhere. In addition, our engineers constructed the **OS-25's** to withstand the stresses and strains of the world outside! For the first time, serious listeners can enjoy a concert on the green in their own back yard.



FEATURES & BENEFITS

Precision Crossover

An electronic dividing network inside the cabinet precisely distributes the music to the woofer and the tweeter. The two-way design of the OS-25's crossover provides excellent stereo imaging and low distortion.

1" Teteron Tweeter

In the past, every weather-resistant speaker has disappointed listeners with a fatiguing and harsh treble sound caused by tweeter ringing. The OS-25's 1" Teteron tweeter utilizes a tri-laminate design consisting of an inner textile layer which forms the dome, a high damping layer to kill unwanted resonances, and an outside layer of urethane to add stiffness and prevent breakup modes. The result is a transparently clear, sweet, natural sounding tweeter which still maintains extended frequency response.

6-1/2" Injection Molded TCC Woofer

The unusually stiff and light injection molded TCC cone, the butyl rubber surround, the substantial magnet, and the rigid steel basket are all optimized for large excursions of the woofer. In this way, the 6-1/2" woofer can create the same deep bass output of a much larger speaker moving small distances in and out. The end result is rich satisfying bass from a compact, weather-resistant loudspeaker.

Rigid, Acoustically Inert Enclosure

The cabinet of the OS-25 is composed of mineral filled polypropylene. This material is extremely non-resonant. All you hear is the music.

Low Diffraction MicroPerf™ Aluminum Grille and Front Baffle

The aluminum MicroPerf™ grille of the OS-25 has hundreds of precisely sized perforations, creating an acoustically transparent grille. The aluminum construction resists oxidation enabling years of trouble-free operation in the harshest conditions. The front baffle is gently curved in a radius optimized for the best sound. Sound waves emanating from the woofer and the tweeter are not reflected by the surrounding parts of the speaker.

Tapering Shape

The cabinet of the OS-25 is shaped so that the speaker will tuck discretely away into corners or under eaves.

Swiveling Bracket

The U-shaped bracket and bracket knobs allow the OS-25 to be pointed at the optimum listening position and locked into place quickly and easily.

Easy Three-Way Mounting System

1. The OS-25 can be hung from a nail using the nail hole on the bracket.
2. The bracket can be screwed into the mounting surface using your hardware.
3. The OS-25 is equipped with 1/4-20 threaded inserts for OmniMount® or custom brackets.

Stable Shelf Placement

The bracket knobs serve as one of the speaker's feet when the OS-25 is placed directly on a shelf or desktop without the bracket. In addition, two feet are molded into the base of the cabinet to give added stability.

PARTS GUIDE

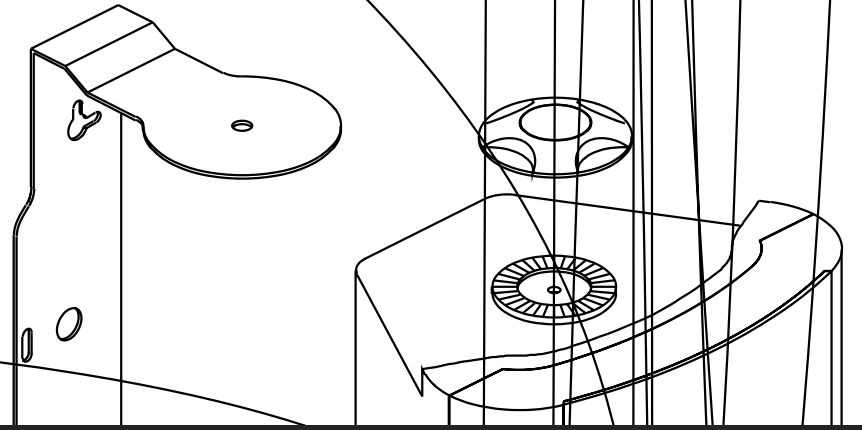

INSTALLATION CONSIDERATIONS

Tools and Materials Required

- A wire stripper
- A pencil
- A level (optional)
- Three screws or bolts suitable for the mounting surface
- The proper screwdriver for your mounting hardware
- A drill bit of the right size and type
- An electric drill

Wiring

The OS-25 connects to your receiver or amplifier using 2-conductor speaker wire (See Figure 2). For most applications, we recommend using 16 or 18 gauge wire. For wiring runs longer than 80 feet, we recommend 14 gauge wire. The binding posts of the OS-25 will accommodate up to 12 gauge wire directly. Larger sizes can be accommodated using spade, banana, or pin connectors.

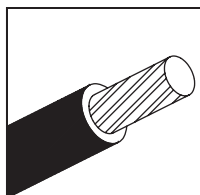

TECH TIP

Wire size is expressed by its AWG (American Wire Gauge) number. The lower the number, the larger the wire, i.e. twelve AWG is physically larger than fourteen AWG.

When you run wire inside walls, outdoors or in marine installations, special jacketing or conduit is required for a trouble-free installation and conformation to the local and national building codes. If you are not sure of the correct wire jacket or type of conduit to use, consult a professional audio/video installer, building contractor, or the local building and inspection department.

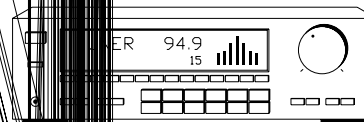

Incorporating a Volume Control

It's possible to control the volume of the sound at the speaker location. Plan to wire the system so that each pair of speakers has it's own volume control. Niles makes a wide range of indoor and outdoor volume controls. Consult your local Niles dealer for more information. Volume controls are connected in line with the speaker, so you must connect the wire from the amplifier to the volume control and then from the volume control to the speaker (See Figure 3).

Recommended Amplifier Power

We recommend an amplifier with a power rating of five to one hundred fifty watts per channel for optimum performance. Ironically, most speakers are not damaged by large amplifiers but by small amplifiers. If you are playing at high volume, a small amplifier will run out of power very quickly. When an amplifier runs out of power it creates damaging "clipping" distortion. A large amplifier will play at the same volume without distorting. See the section "Operation" for more information about clipping distortion.

Placing the OS-25 for the Best Sound Quality

The OS-25's dispersion pattern is very broad. The speaker is very sensitive and will handle a lot of amplifier power. This allows good sound quality over an extremely large listening area. However, if a single pair is positioned to provide coverage of a very large room or patio, you will have "hot spots" of loud sound when you are near the speakers. The best way to avoid hot spots for a large space is to use several pairs. A good rule of thumb is a pair of speakers for every 200 to 400 square feet of listening area. Your local Niles dealer is a good source for advice on speaker placement for your particular installation.

When using more than one pair, it is usually best to alternate a left channel and then a right channel, so that you never have a "left next to a left".

The position of the speakers and the surroundings around them play a very important role in how a stereo image is created. You should experiment to find the very best position for your speakers. Here are some guidelines to make the process quick and easy.

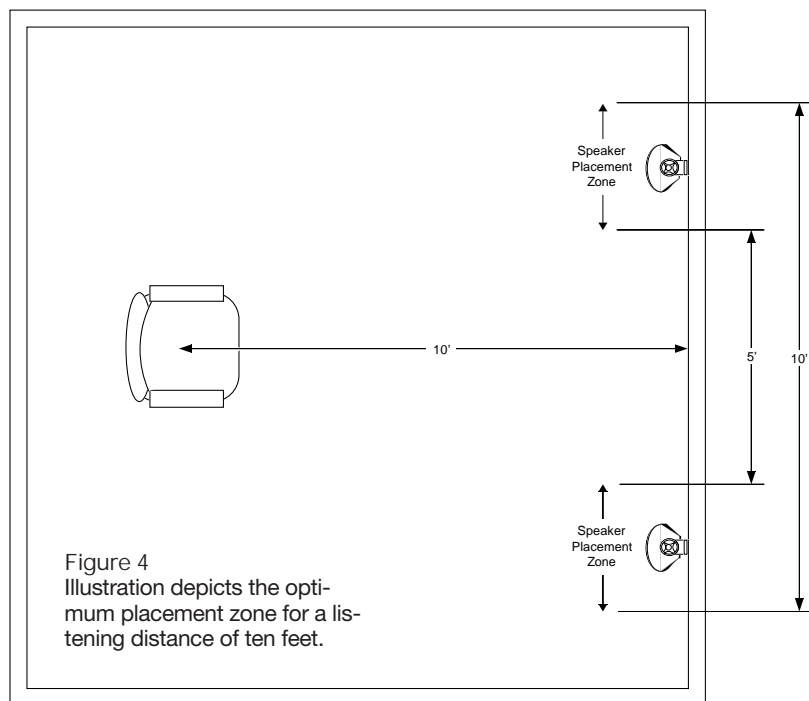

Make sure you are not blocking or reflecting the sound off of furniture or other objects. You should have a direct line of sight with the front of the speaker. To determine the best position, measure the distance between the ideal listening position and the wall you plan to mount the speakers on. Try to place the speakers so that they are at least one-half the listening distance apart (this maintains a large, pleasant stereo "image") and less than the entire listening distance (this avoids a "hole-in-the-middle" effect). For example; if you are ten feet back from the wall, the speakers should be between five and ten feet apart (See Figure 4).

You can control the speakers bass output by placement. This is called the boundary effect. You will get more bass response by mounting the OS-25 directly to a wall or other flat surface (any boundary close to the speaker will reinforce the bass frequencies). You can increase the bass output even more by mounting the OS-25 in a corner or under an eave (See Figure 5) This type of placement gives the speaker two boundaries, both reinforcing the bass sounds. Of course, if you wish to hear less bass, try moving the speaker away from the boundary (See Figure 6).

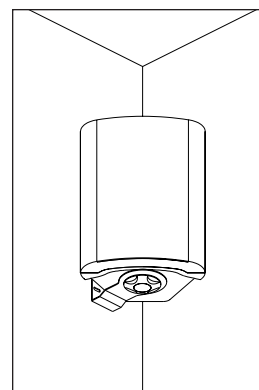

Figure 5
Placement for more bass output

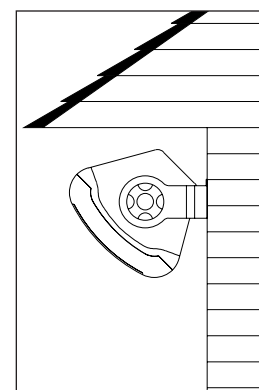
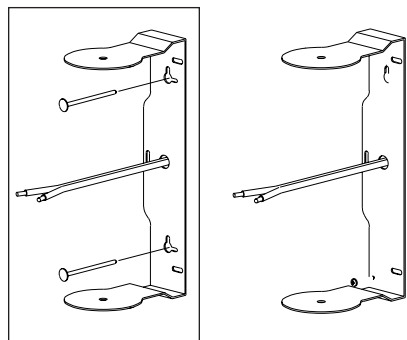

Figure 6
Placement for less bass output

Mounting Methods

The OS-25 can be mounted either horizontally or vertically. The bracket knobs will keep the speaker angled correctly in any position once they are tightened. You can choose from three mounting methods to attach the OS-25 to the wall, ceiling, or other mounting surface.

1. If the speaker is never going to be exposed to sudden accidental impacts, wind, waves or earthquakes you can simply hang it on a nail using the nail hole(s) of the bracket (See Figure 7).



2. The safest and most secure way to mount the speaker is by screwing it to the mounting surface using your own hardware (suitable for the surface you are mounting to) and the bracket supplied with the speaker (See Figure 7).

PAINTING THE OS-25

The enclosure, the brackets, and the grills of the OS-25 can all be painted to match the surroundings. Because we want you to preserve the acoustic qualities of the grille, please paint the grille according to the grille painting instructions. Make sure you pick a paint that is appropriate for the mounting location. There are interior and exterior varieties, and even paint for marine uses. If you are not sure what paint to use, consult a paint store professional or a painter.

Tools Required

- A spray can of primer paint (Krylon Sandable Spray Primer #1318)
- The correct paint for the surroundings (oil or water based paint is fine)
- A paint brush or applicator if the paint is not in a spray can.
- A paper clip or a corkscrew (for removing the grille)
- Masking tape
- 2 paint masks (supplied)
- A damp cloth and a dry cloth

2. Wipe off the other sides of the cabinet, the bracket, bracket knobs, and grille with a damp cloth. Do not touch or rub the speakers on the front baffle. Make sure everything is dry before masking.
3. Mask off the binding posts and the brass threaded inserts on the back panel with masking tape.
4. Mask off the threaded inserts on the top and bottom with masking tape.
5. Protect the front of the speakers by inserting the supplied paint masks in place of the grills.

Painting the Cabinet, Bracket Knobs and Bracket

1. Apply two thin coats of a primer to the cabinet and knobs. We recommend Krylon Sandable Spray Primer #1318. The bracket doesn't require a coat of primer.
2. Allow the primer to completely dry.
3. Apply the finish color.
4. Allow the paint to completely dry.
5. Carefully remove the masking material.
6. Do not reattach the speaker to the bracket e8 To the bracket es dmundted. TryTj0

If you are using an applicator or brush and a can of paint, thin the paint first. Thick paint will tend to clog the grille holes.

Replacing the Grille

Carefully fit the grille into its recess so that it is barely in place. Starting with one corner, go around the speaker, pushing the grille in a little bit each time. You should be gentle, the aluminum grille can be easily bent out of shape. You will feel a positive "snap" when it is fully in place.

INSTALLATION

Mounting the Bracket

1. Remove the bracket knobs and the bracket from the speaker.
2. Hold the bracket up to the mounting surface. The speaker can be mounted either horizontally or vertically. Hold the bracket so that the speaker wire fits through the large, circular wire hole in the bracket. Align the bracket to be square with the surroundings (use a level for accuracy).
3. Mark the locations of the three oval-shaped screw holes (See Figure 9). Be sure to use all of the holes.
4. Drill pilot holes into the mounting surface.

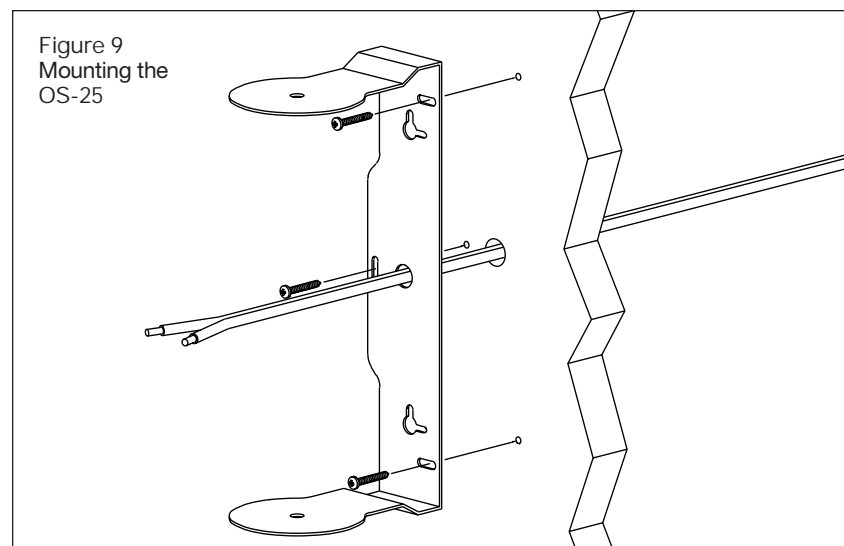

5. Pull the speaker wire through the wire hole in the center of the mounting bracket. Align the bracket so that the holes all line up.
6. Use your hardware to attach the bracket to the mounting surface.

Connecting the Speaker

1. Separate the two conductors of the speaker wire so that at least two inches of each conductor are free.
2. Strip one half inch of insulation from the end of each conductor of the speaker wire.
3. If you have any connectors (gold pins or bananas) which you prefer to use, affix them to the stripped wire ends now. Only gold plated connectors should be used outside as they will not tarnish or corrode.
4. Use the bracket knobs to attach the speaker to the bracket. Do not tighten the knobs completely. Angle the speaker so that the rear terminals are accessible.
5. Connect one stripped wire end (or connector) to the black and one to the red terminal. Pay attention to the markings on the wire. Each speaker must be connected to the amplifier in the same way.

Speaker Phase

Speaker wire has two conductors. One conductor is attached to the negative (-) terminals and one conductor is attached to the positive (+) terminals of both your speaker and your amplifier. Usually, the wire is marked for your convenience. There are different ways to mark the wire; a stripe on one wire, a ribbed area of one conductor you can only feel, different colors of metal wire on each conductor, or there might be a fabric strand or string wound into one of the conductors. Of course, there are some wires which appear completely identical. Be careful to avoid mistakes. If you do, one speaker will be playing out of "phase" with the other speaker. An out-of-phase pair of speakers work against each other and the sound of the two speakers playing together will be lacking in bass and "phasey" sounding. If you suspect the sound is not right and you cannot see any markings on the wire, try this simple test:

1. Point the speakers at each other, rather than at you.
2. Play some music with the amplifier or radio set to Mono.

3. Stand so you are the same distance from each speaker and listen to the richness of the bass and the loudness of the sound.
4. Turn off the amplifier and reverse the connections on one speaker only.
5. Repeat the listening test with the same setting of the volume control. When the sound has a richer bass and is slightly louder the speakers are working together or "in-phase".

Final Adjustments

1. After checking that the speaker is in phase and works correctly, angle the speaker for the best sound.
2. Tighten the bracket knobs using only your hands. Use of any power tools may over-tighten the knob, and strip the threads of the insert.
3. Check that the entire installation is safe and secure.

OPERATION

Listening at Higher Volumes

Outdoors there are no walls to reflect and contain the sound. It requires more power to achieve a reasonable volume of sound outside than it does when you are indoors. You also frequently find yourself very far from the speaker. It is possible to turn the volume so high that the amplifier runs out of power. This creates "clipping" distortion.

Clipping distortion makes treble sound very harsh and unmusical. When you hear harsh sounding treble from any good speaker indoors or outdoors, turn the volume down immediately! Those harsh sounds are masking some much more powerful ultra-high-frequency sound spikes which will quickly damage any fine loudspeaker.

Cleaning

You can clean the OS-25's with a dampened soft cloth or paper towel. If the speaker is mounted high up on a wall or ceiling, use a broom to gently brush it off. Hosing off the speaker is not recommended, as the tweeter is a precise mechanism which might be damaged by a high pressure stream of water.

SPECIFICATIONS**Recommended Amplifier Power**

Five to one hundred fifty watts per channel

Nominal Impedance

4 Ohms

Frequency Response

68 Hz to 21 kHz, plus or minus 3 dB (on axis)

Sensitivity

91 decibels for 2.83 volts of Pink Noise, measured at 1 meter on axis

Wiring Requirements

Sixteen to eighteen gauge 2-conductor (unshielded or shielded) wire for runs up to eighty feet. Fourteen gauge 2-conductor (unshielded or shielded) wire for runs up to two hundred feet.

Temperature Extremes

-50° to 200° Fahrenheit

Dimensions (Speaker without U-Bracket)

9-7/8" Wide x 13" High x 7-1/4" Deep

Dimensions (Speaker with U-Bracket)

9-7/8" Wide x 13" High x 9" Deep

Weight (Speaker and Bracket)

9 lbs.

PLEASE FILL OUT THE
WARRANTY REGISTRATION
CARD ON THE REVERSE SIDE,
DETACH, AND MAIL TO:

Niles Audio Corporation
Warranty Registration Dept.
P.O. Box 160818
Miami, Florida 33116-0818

DETACH HERE

WARRANTY REGISTRATION CARD

Model Purchased _____

Serial Number _____

Date Purchased (month/day/year) _____

Dealer Name and Location _____

Dr. Miss Mr. Mrs. Ms.

Name _____

Address _____

City _____ State _____ Zip _____

Telephone (_____) _____

Please take a moment to fill out our warranty registration card. The information helps us to get to know you better and develop the products you want

Age:

- Under 25
- 25-34
- 35-44
- 45-54
- 55 & over

Income:

- Under \$24,999
- \$25,000-\$34,999
- \$35,000-\$44,999
- \$45,000-\$59,999
- \$60,000-\$74,999
- \$75,000-\$99,999
- Over \$99,999

Occupation:

- Arts/Entertainment
- Business Owner
- Engineer
- Finance/Accounting
- General Office
- Management
- Professional
- Sales/Marketing
- Student
- Tradesperson

Musical tastes:

(Please check all that apply)

- Alternative
- Classical
- Country
- Jazz
- New Age
- Popular
- R&B
- Rock
- Other _____

How did you hear about Niles?

- Architect/Developer
- Custom Installer
- Direct Mail
- Friend/Family
- In-Store Display
- Interior Designer
- Magazine Ad
- Mail-Order Catalog
- Newspaper Ad
- Product Brochure
- Product Review
- Retail Salesperson

What magazines do you read?

1. _____
2. _____
3. _____

Who will install the product?

- Custom Installer
- Electrician
- Friend
- Myself

Which factor(s) influenced the purchase of your Niles product?

(Please check all that apply)

- Ease of Use
- Price/Value
- Product Features
- Quality/Durability
- Reputation
- Style/Appearance
- Warranty

Do you . . . ?

Own a House. If yes, how many square feet? _____

- Own a Town House/Condominium/Co-op
- Rent an Apartment
- Rent a House

Are you interested in receiving literature on other Niles products?

- Yes No

Are there products/capabilities that you would like to see introduced?

- _____
- _____
- _____
- _____

DETACH HERE AND RETURN TO: Niles Audio Corporation Warranty Registration Dept. P.O. Box 160818 Miami, Florida 33116-0818

LIMITED WARRANTY

Niles Audio Corporation ("NILES") warrants its outdoor loudspeaker products to the original purchaser to be free of manufacturing defects in material and workmanship for a period of two years from date of purchase.

This Warranty is subject to the following additional conditions and limitations. The Warranty is void and inapplicable if NILES deems that the product has been used or handled other than in accordance with the instructions provided by the manufacturer, including but not limited to damage caused by accident, mishandling, improper installation, abuse, negligence, or normal wear and tear, or any defect caused by repair to the product by anyone other than NILES or an authorized NILES dealer.

To obtain warranty service, take the unit to the nearest authorized NILES dealer, who will test the product and if necessary, forward it to NILES for service. If there are no authorized NILES dealers in your area, you must write to NILES and include your name, model and serial number of your unit, along with a brief description of the problem. A factory Return Authorization Number will be sent to you. **DO NOT RETURN ANY UNIT WITHOUT FIRST RECEIVING WRITTEN AUTHORIZATION AND SHIPPING INSTRUCTIONS FROM NILES.**

If the above conditions are met, the purchaser's sole remedy shall be to return the product to NILES, in which case NILES will repair or replace, at its sole option, the defective product without charge for parts or labor. NILES will return a unit repaired or replaced under warranty by shipping same by its usual shipping method from the factory (only) at its expense within the United States of America. **THERE ARE NO OTHER WARRANTIES, INCLUDING WITHOUT LIMITATION, EITHER EXPRESS OR IMPLIED WARRANTIES OF MERCHANTABILITY OR FITNESS FOR A PARTICULAR PURPOSE, WITH RESPECT TO THE PRODUCT.**

REPAIR OR REPLACEMENT AS PROVIDED UNDER THIS WARRANTY IS THE EXCLUSIVE REMEDY OF THE CONSUMER/PURCHASER. NILES SHALL NOT BE RESPONSIBLE FOR ANY INCIDENTAL OR CONSEQUENTIAL DAMAGES EXCEPT TO THE EXTENT PROVIDED (OR PROHIBITED) BY APPLICABLE LAW.

Some states do not allow the exclusion or limitation of incidental or consequential damages, so the above limitation may not apply to you. This warranty gives you specific legal rights, and you may also have other rights which vary from state to state.

For the name of your nearest authorized NILES dealer contact:

NILES AUDIO CORPORATION
P.O. BOX 160818, Miami, Florida 33116-0818.

Please fill in your product information and retain for your records.

Model _____

Serial No. _____

Purchase Date _____

Free Manuals Download Website

<http://myh66.com>

<http://usermanuals.us>

<http://www.somanuals.com>

<http://www.4manuals.cc>

<http://www.manual-lib.com>

<http://www.404manual.com>

<http://www.luxmanual.com>

<http://aubethermostatmanual.com>

Golf course search by state

<http://golfingnear.com>

Email search by domain

<http://emailbydomain.com>

Auto manuals search

<http://auto.somanuals.com>

TV manuals search

<http://tv.somanuals.com>