

NordicTrack[®] Reflex 8500 PRO

www.nordictrack.com

Model No. NTL11909.0

Serial No. _____

Write the serial number in the space above for reference.

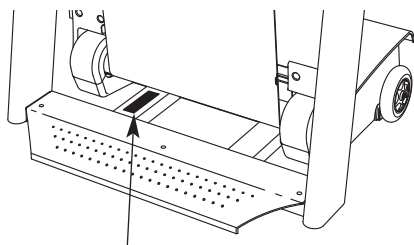

Serial Number Decal

USER'S MANUAL

QUESTIONS?

If you have questions, or if parts are damaged or missing, **DO NOT CONTACT THE STORE**; please contact Customer Care.

IMPORTANT: Please register this product (see the limited warranty on the back cover of this manual) before contacting Customer Care.

CALL TOLL-FREE:

1-888-825-2588

Mon.–Fri. 6 a.m.–6 p.m. MT

Sat. 8 a.m.–4 p.m. MT

ON THE WEB:

www.nordictrackservice.com

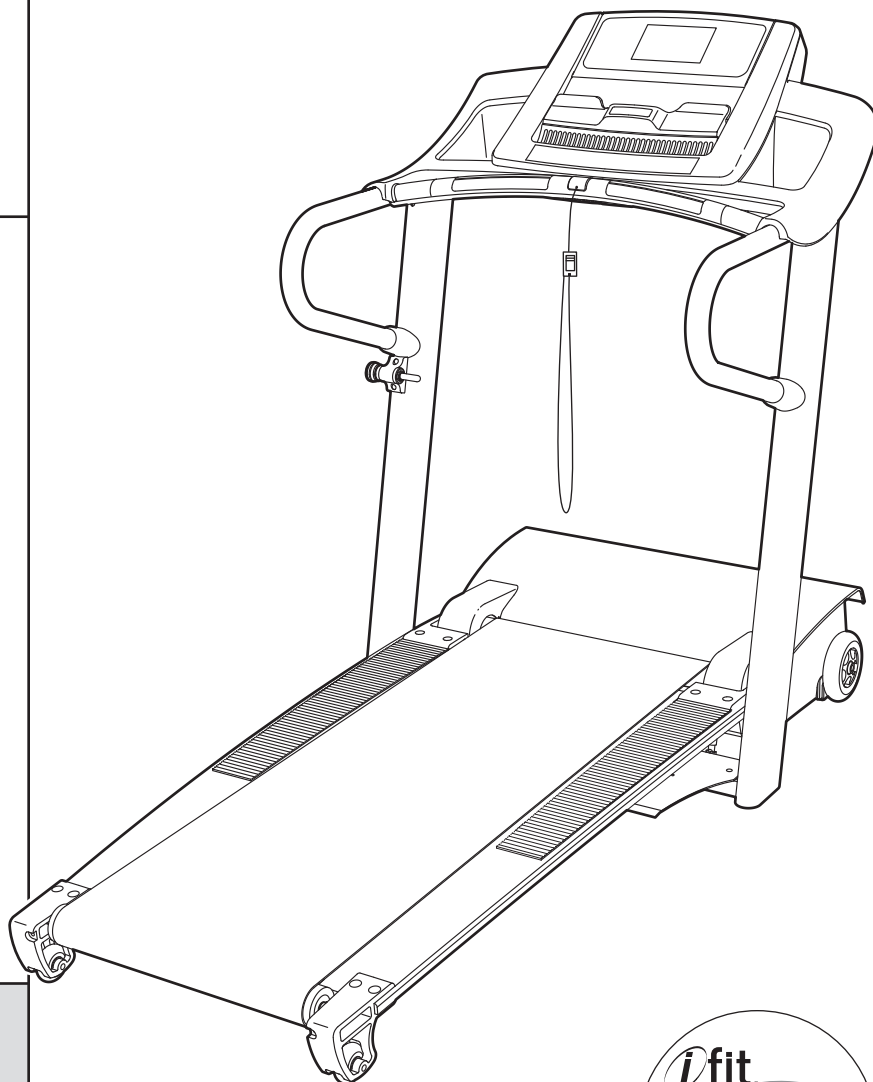

CAUTION

Read all precautions and instructions in this manual before using this equipment. Save this manual for future reference.



TABLE OF CONTENTS

WARNING DECAL PLACEMENT2
IMPORTANT PRECAUTIONS3
BEFORE YOU BEGIN5
ASSEMBLY6
OPERATION AND ADJUSTMENT12
HOW TO FOLD AND MOVE THE TREADMILL24
TROUBLESHOOTING26
EXERCISE GUIDELINES29
PART LIST30
EXPLODED DRAWING32
ORDERING REPLACEMENT PARTS	Back Cover
LIMITED WARRANTY	Back Cover

WARNING DECAL PLACEMENT

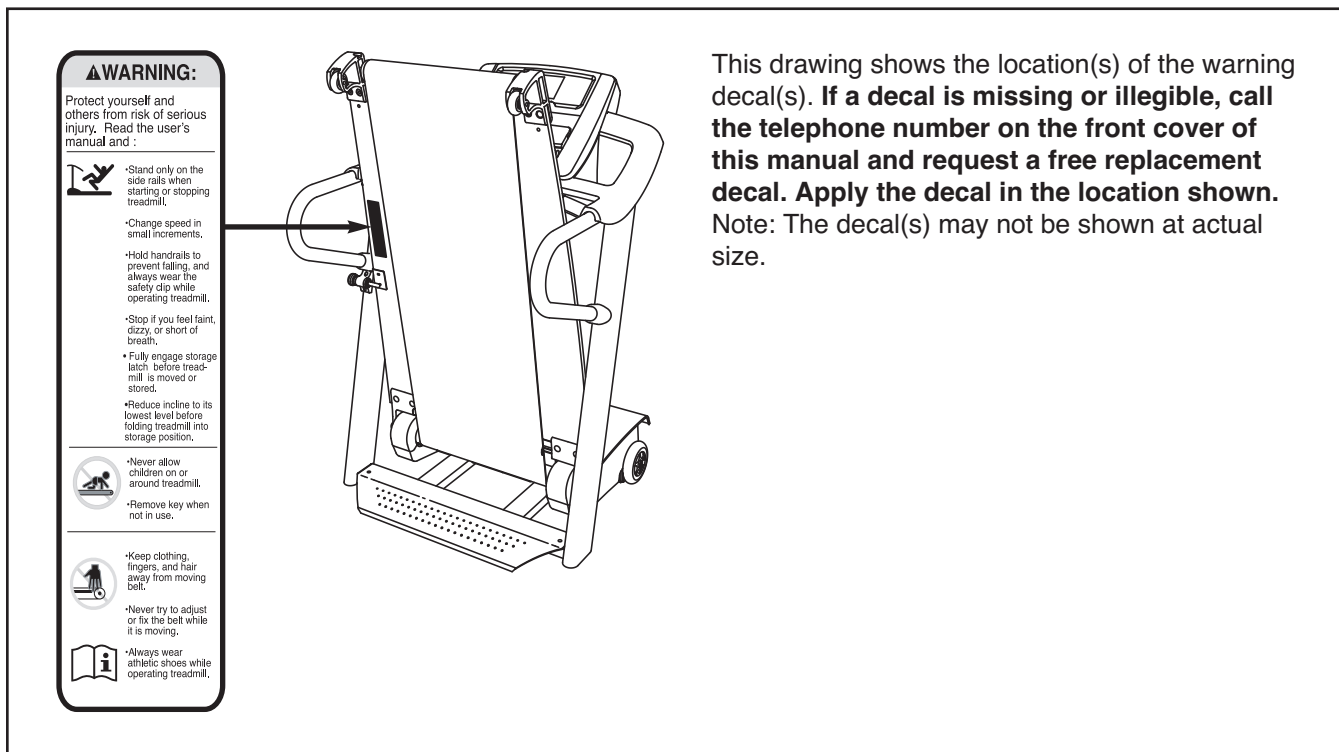

IMPORTANT PRECAUTIONS

⚠ WARNING: To reduce the risk of serious injury, read all important precautions and instructions in this manual and all warnings on your treadmill before using your treadmill. ICON assumes no responsibility for personal injury or property damage sustained by or through the use of this product.

1. Before beginning any exercise program, consult your physician. This is especially important for persons over age 35 or persons with pre-existing health problems.
2. It is the responsibility of the owner to ensure that all users of this treadmill are adequately informed of all warnings and precautions.
3. Use the treadmill only as described.
4. Place the treadmill on a level surface, with at least 8 ft. (2.4 m) of clearance behind it and 2 ft. (0.6 m) on each side. Do not place the treadmill on any surface that blocks air openings. To protect the floor or carpet from damage, place a mat under the treadmill.
5. Keep the treadmill indoors, away from moisture and dust. Do not put the treadmill in a garage or covered patio, or near water.
6. Do not operate the treadmill where aerosol products are used or where oxygen is being administered.
7. Keep children under age 12 and pets away from the treadmill at all times.
8. The treadmill should be used only by persons weighing 350 lbs. (159 kg) or less.
9. Never allow more than one person on the treadmill at a time.
10. Wear appropriate exercise clothes when using the treadmill. Do not wear loose clothes that could become caught in the treadmill. Athletic support clothes are recommended for both men and women. *Always wear athletic shoes. Never use the treadmill with bare feet, wearing only stockings, or in sandals.*
11. When connecting the power cord (see page 12), plug the power cord into a surge suppressor (not included) and plug the surge suppressor into a grounded circuit capable of carrying 15 or more amps. No other appliance should be on the same circuit. Do not use an extension cord.
12. Use only a single-outlet surge suppressor that meets all of the specifications described on page 12. To purchase a surge suppressor, see your local NordicTrack dealer or call the telephone number on the front cover of this manual and order part number 146148, or see your local electronics store.
13. Failure to use a properly functioning surge suppressor could result in damage to the control system of the treadmill. If the control system is damaged, the walking belt may slow, accelerate, or stop unexpectedly, which may result in a fall and serious injury.
14. Keep the power cord and the surge suppressor away from heated surfaces.
15. Never move the walking belt while the power is turned off. Do not operate the treadmill if the power cord or plug is damaged, or if the treadmill is not working properly. (See TROUBLESHOOTING on page 26 if the treadmill is not working properly.)
16. Read, understand, and test the emergency stop procedure before using the treadmill (see HOW TO TURN ON THE POWER on page 14).
17. Never start the treadmill while you are standing on the walking belt. Always hold the handrails while using the treadmill.
18. The treadmill is capable of high speeds. Adjust the speed in small increments to avoid sudden jumps in speed.
19. The pulse sensor is not a medical device. Various factors, including the user's movement, may affect the accuracy of heart rate readings. The pulse sensor is intended only as exercise aids in determining heart rate trends in general.

20. Never leave the treadmill unattended while it is running. Always remove the key, unplug the power cord, and switch the reset/off circuit breaker to the off position when the treadmill is not in use. (See the drawing on page 5 for the location of the reset/off circuit breaker.)
21. Do not attempt to raise, lower, or move the treadmill until it is properly assembled. (See ASSEMBLY on page 6, and HOW TO FOLD AND MOVE THE TREADMILL on page 24.) You must be able to safely lift 45 lbs. (20 kg) to raise, lower, or move the treadmill.
22. Do not change the incline of the treadmill by placing objects under the treadmill.
23. When folding or moving the treadmill, make sure that the storage latch is holding the frame securely in the storage position.
24. Inspect and properly tighten all parts of the treadmill regularly.
25. Never insert or drop any object into any opening on the treadmill.
26. **DANGER:** Always unplug the power cord immediately after use, before cleaning the treadmill, and before performing the maintenance and adjustment procedures described in this manual. Never remove the motor hood unless instructed to do so by an authorized service representative. Servicing other than the procedures in this manual should be performed by an authorized service representative only.
27. The treadmill is intended for in-home use only. Do not use the treadmill in any commercial, rental, or institutional setting.
28. Over exercising may result in serious injury or death. If you feel faint or if you experience pain while exercising, stop immediately and cool down.

SAVE THESE INSTRUCTIONS

BEFORE YOU BEGIN

Thank you for selecting the revolutionary NordicTrack® REFLEX 8500 PRO treadmill. The REFLEX 8500 PRO treadmill offers an impressive selection of features designed to make your workouts at home more enjoyable and effective. And when you're not exercising, the unique treadmill can be folded up, requiring less than half the floor space of other treadmills.

For your benefit, read this manual carefully before using the treadmill. If you have questions after read-

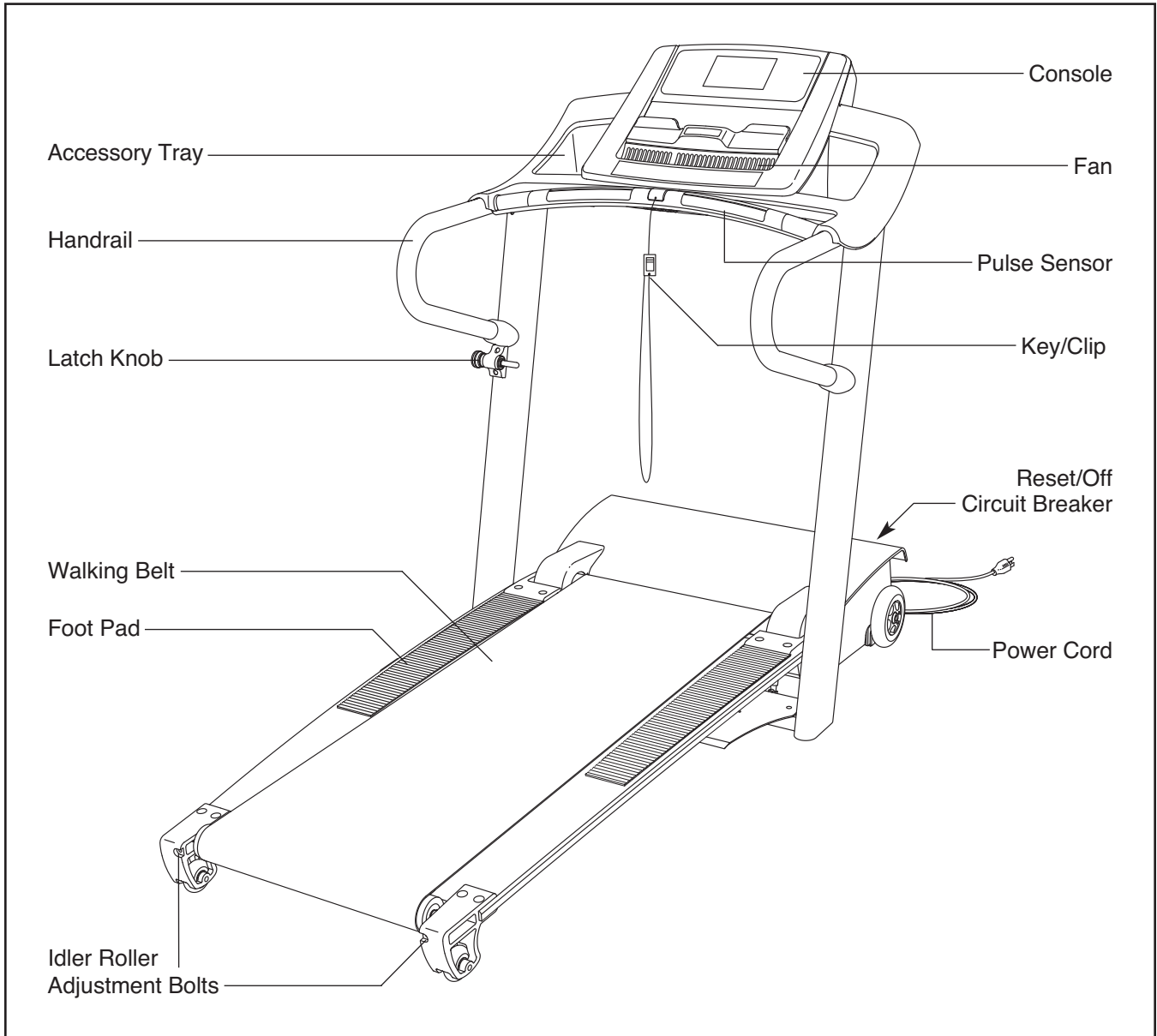

ing this manual, please see the front cover of this manual. To help us assist you, note the product model number and serial number before contacting us. The model number and the location of the serial number decal are shown on the front cover of this manual.

Before reading further, please look at the drawing below and familiarize yourself with the labeled parts.

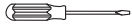
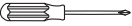

ASSEMBLY

Assembly requires two persons. Set the treadmill in a cleared area and remove all packing materials. **Do not dispose of the packing materials until assembly is completed.** Note: The underside of the treadmill walking belt is coated with high-performance lubricant. During shipping, some lubricant may be transferred to the top of the walking belt or the shipping carton. This is normal and does not affect treadmill performance. If there is lubricant on top of the walking belt, simply wipe off the lubricant with a soft cloth and a mild, non-abrasive cleaner.

Assembly requires the included hex key  and your own standard screwdriver  , Phillips screwdriver  , and wire cutters .

Use the drawings below to identify the assembly hardware. The number in parentheses below each drawing is the key number of the part, from the PART LIST near the end of this manual. The number after the parentheses is the quantity needed for assembly. **Note: If a part is not in the hardware kit, check to see if it is preattached to one of the parts to be assembled. To avoid damaging parts, do not use power tools for assembly. Extra hardware may be included.**

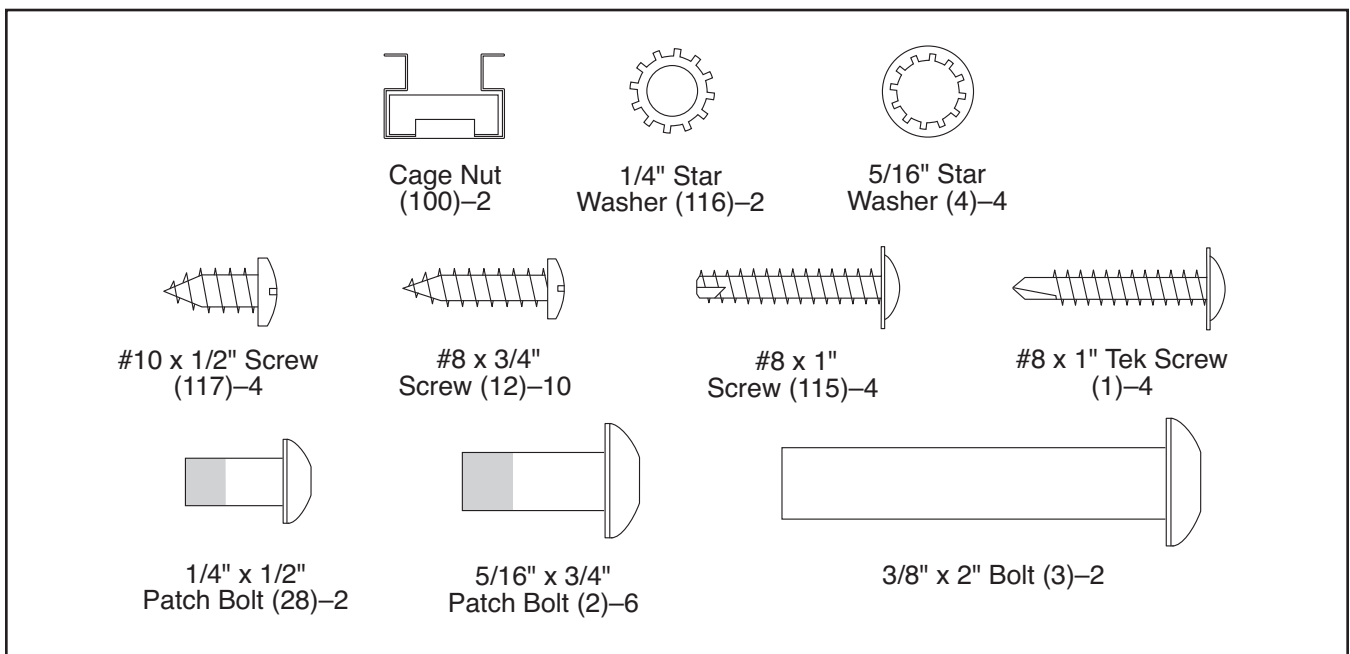

1. With the help of a second person, tip the Uprights (43) down as shown.

Insert the two Cage Nuts (100) into the indicated holes in the Uprights (43). To insert each Cage Nut, first hook one side of the Cage Nut into a hole. Then, use a standard screwdriver to press the other side of the Cage Nut into the hole, as shown in the inset drawing.

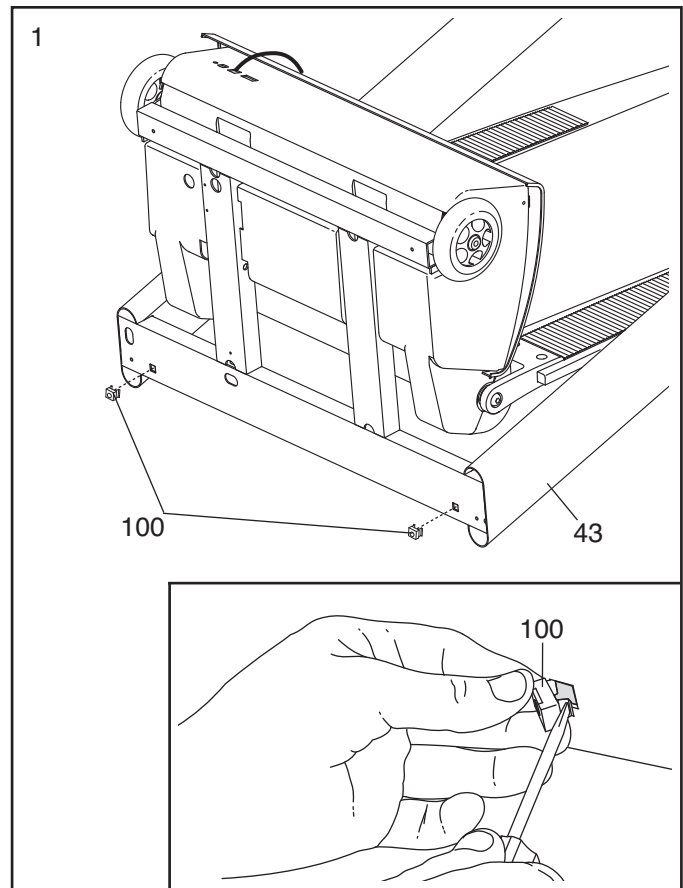

2. Attach the four Base Feet (96) to the base of the Uprights (43) with four #8 x 1" Tek Screws (1).

Raise the Uprights (43).

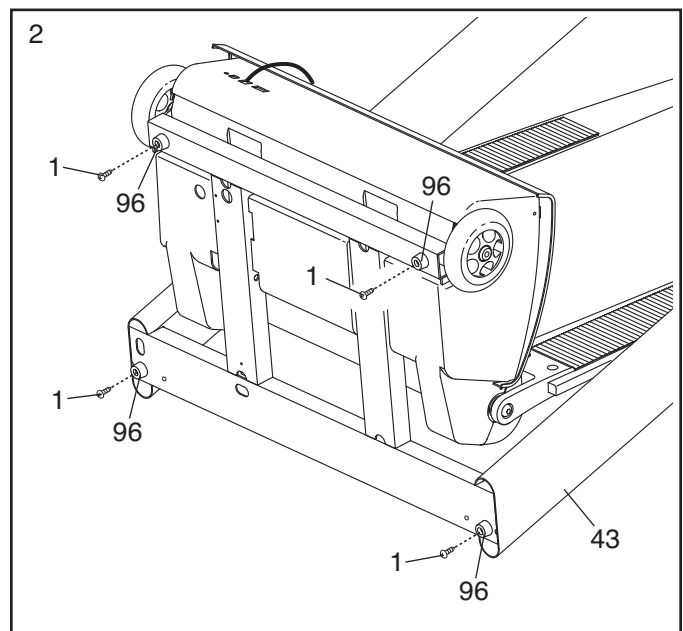

3. Identify the Left Handrail (101). Cut the tie from the Left Handrail. If necessary, press the 5/16" Cage Nut (99) back into place.

Slide a Handrail Cover (103) onto the lower end of the Left Handrail (101) as shown. Set the Left Handrail on the left Upright (43) and slide the lower end of the Left Handrail onto the bracket on the left Upright.

Start three 5/16" x 3/4" Patch Bolts (2) with two 5/16" Star Washers (4) into the left Upright (43) and the Left Handrail (101). Then, start two #10 x 1/2" Screws (117). **Firmly tighten the three Bolts and the two Screws.**

Slide the Handrail Cover (103) against the left Upright (43).

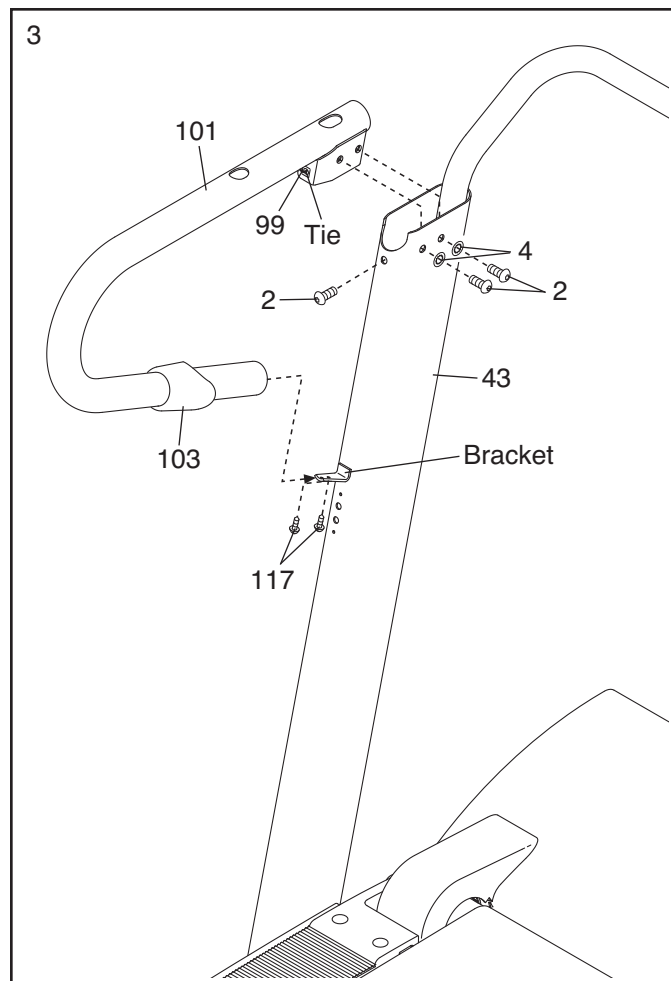

4. Cut the tie from the Right Handrail (102). If necessary, press the 5/16" Cage Nut (99) back into place.

Cut the tie holding the Upright Wire (93). Route the Upright Wire through the Right Handrail (102) as shown.

Slide a Handrail Cover (103) onto the lower end of the Right Handrail (102) as shown. Set the Right Handrail on the right Upright (43) and slide the lower end of the Right Handrail onto the bracket on the right Upright. **Make sure not to pinch the Upright Wire (93).**

Start three 5/16" x 3/4" Patch Bolts (2) with two 5/16" Star Washers (4) into the right Upright (43) and the Right Handrail (102). Then, start two #10 x 1/2" Screws (117). **Firmly tighten the three Bolts and the two Screws.**

Slide the Handrail Cover (103) against the right Upright (43).

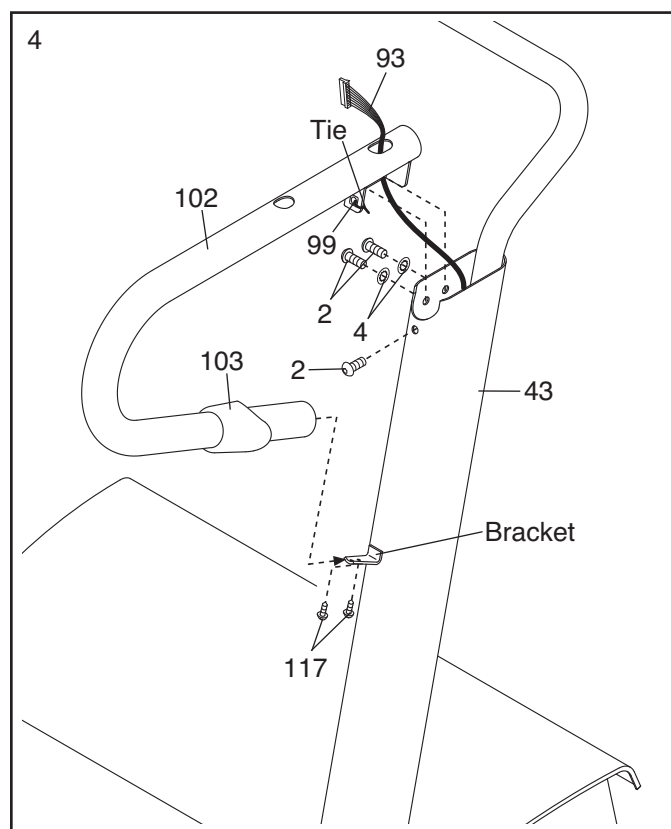

5. Set the console assembly face-down on a soft surface to avoid scratching the console assembly. Attach the Left Accessory Tray (110) and the Right Accessory Tray (111) to the console assembly with eight #8 x 3/4" Screws (12).

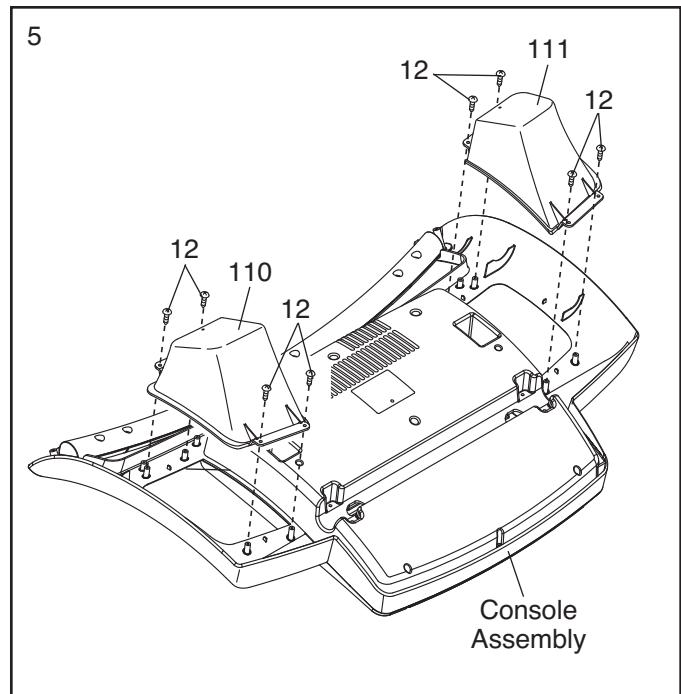

6. With the help of a second person, hold the console assembly near the Uprights (43). Connect the Console Ground Wire (55) to the Ground Wire (105).

Next, connect the console wire to the Upright Wire (93). **See the inset drawing. The connectors should slide together easily and snap into place.** If they do not, turn one connector and try again. **IF THE CONNECTORS ARE NOT CONNECTED PROPERLY, THE CONSOLE MAY BE DAMAGED WHEN YOU TURN ON THE POWER.** Then, insert the wires into the Right Handrail (102) and the right Upright (43).

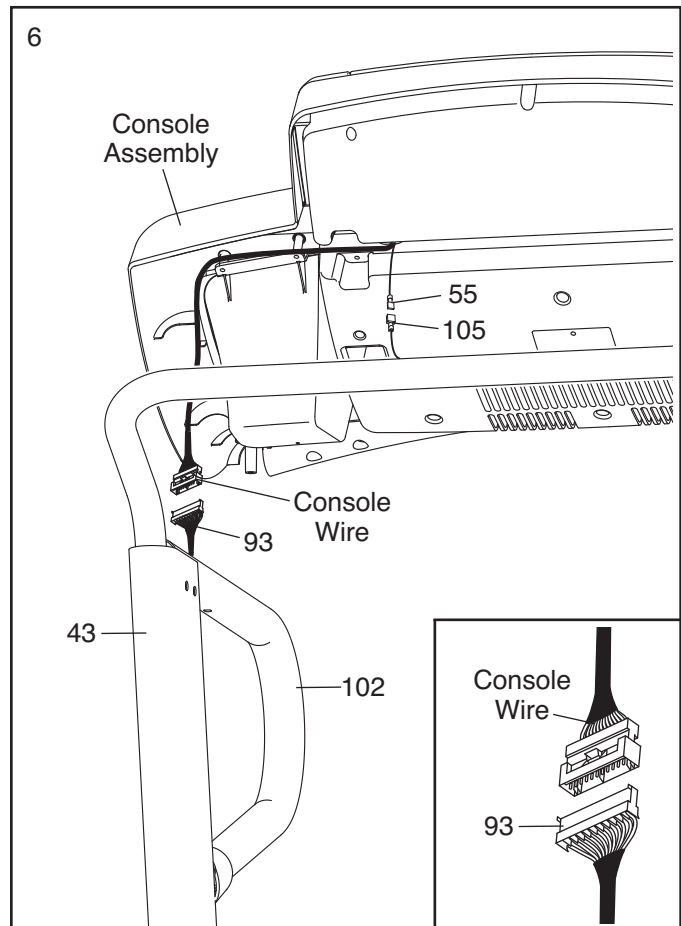

7. Set the console assembly on the Left and Right Handrails (101, 102) and the Uprights (43). **Be careful not to pinch any wires.**

Tighten two 1/4" x 1/2" Patch Bolts (28) with two 1/4" Star Washers (116) into the Handrails (101, 102) and the console assembly. **Do not fully tighten the Patch Bolts yet.**

Attach the two Console Clamps (104) to the console assembly with four #8 x 1" Screws (115). **Start all four Screws, and then tighten all of them. Be careful not to overtighten the Screws.**

Tighten the two 1/4" x 1/2" Patch Bolts (28).

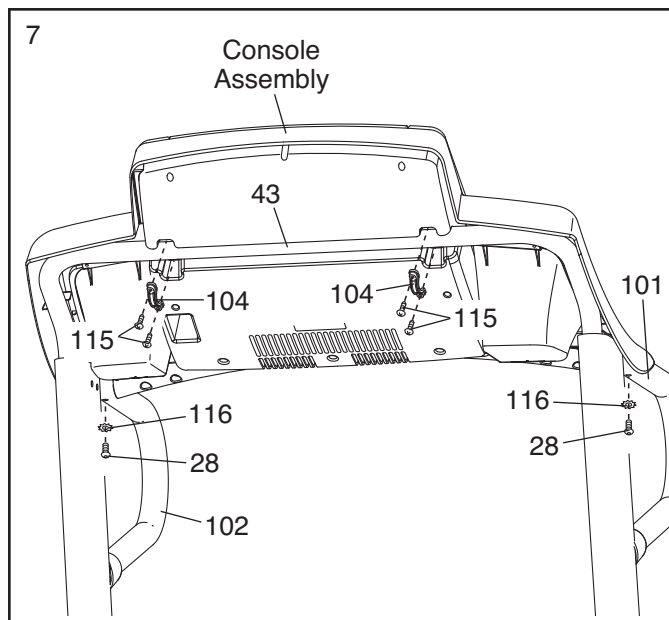

8. **Orient the Latch Housing (89) so that the large hole is on the side shown.** Attach the Latch Housing to the left Upright (43) with two #8 x 3/4" Screws (12). **Do not overtighten the Screws.**

Locate the Latch Assembly (88). Remove the knob from the pin; make sure that the collar and the spring are on the pin. Then, insert the pin into the Latch Housing (89), and tighten the knob back onto the pin.

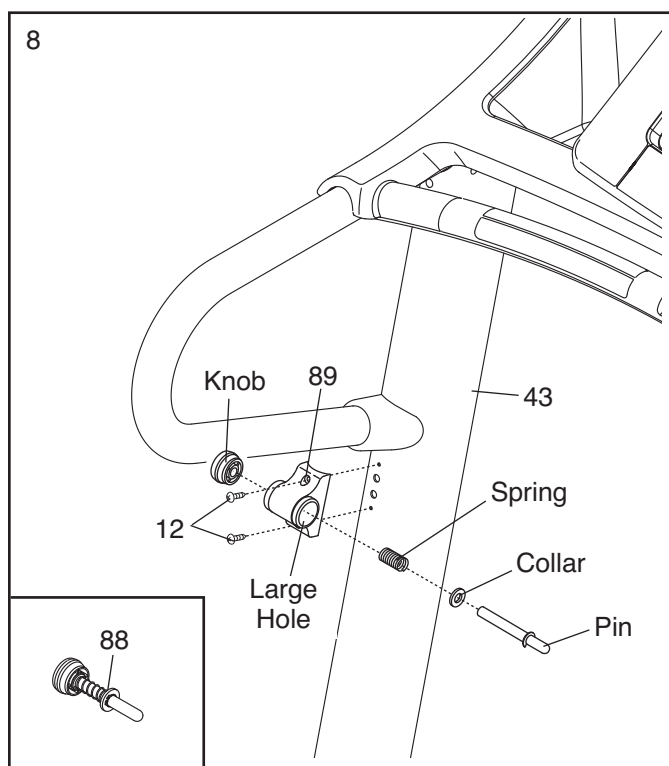

9. Place the treadmill in the storage position (see HOW TO FOLD THE TREADMILL on page 24).

Position the Base Plate (97) on the treadmill as shown. Attach the Base Plate to the Uprights (43) with two 3/8" x 2" Bolts (3). Note: It may be helpful if a second person tips the treadmill slightly as you tighten the Bolts.

Lower the treadmill (see HOW TO LOWER THE TREADMILL FOR USE on page 25).

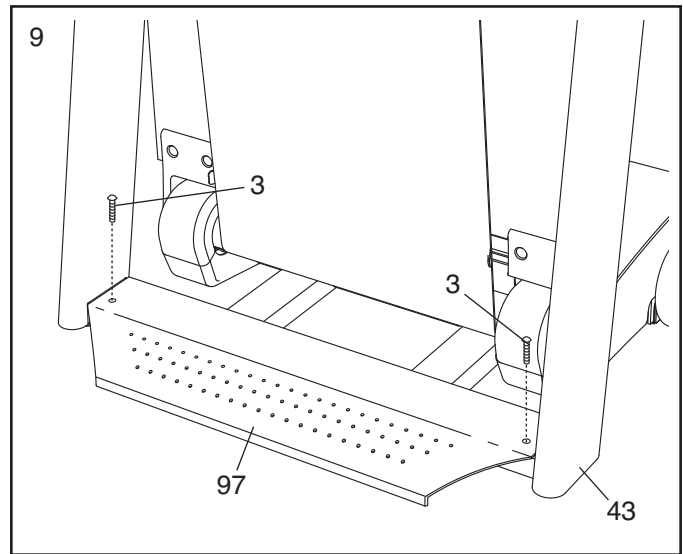

10. **Make sure that all parts are properly tightened before you use the treadmill.** Keep the included hex key in a secure place; the hex key is used to adjust the walking belt (see pages 27 and 28). **To protect the floor or carpet from damage, place a mat under the treadmill.**

OPERATION AND ADJUSTMENT

THE PRE-LUBRICATED WALKING BELT

Your treadmill features a walking belt coated with high-performance lubricant. **IMPORTANT: Never apply silicone spray or other substances to the walking belt or the walking platform. Such substances will deteriorate the walking belt and cause excessive wear.**

HOW TO PLUG IN THE POWER CORD

⚠ DANGER: Improper connection of the equipment-grounding conductor can result in an increased risk of electric shock. Check with a qualified electrician or serviceman if you are in doubt as to whether the product is properly grounded. Do not modify the plug provided with the product—if it will not fit the outlet, have a proper outlet installed by a qualified electrician.

Your treadmill, like any other type of sophisticated electronic equipment, can be seriously damaged by sudden voltage changes in your home's power. Voltage surges, spikes, and noise interference can result from weather conditions or from other appliances being turned on or off. **To decrease the possibility of your treadmill being damaged, always use a surge suppressor with your treadmill (see drawing 1 at the right).** To purchase a surge suppressor, see your local NordicTrack dealer or call the telephone number on the front cover of this manual and order part number 146148, or see your local electronics store.

Use only a single-outlet surge suppressor that is UL 1449 listed as a transient voltage surge suppressor (TVSS). The surge suppressor must have a UL suppressed voltage rating of 400 volts or less and a minimum surge dissipation of 450 joules. The surge suppressor must be electrically rated for 120 volts AC and 15 amps. There must be a monitoring light on the surge suppressor to indicate whether it is functioning properly. Failure to use a properly functioning surge suppressor could result in damage to the control system of the treadmill. If the control system is damaged, the walking belt may slow, accelerate, or stop unexpectedly, which may result in a fall and serious injury.

This product must be grounded. If it should malfunction or break down, grounding provides a path of least resistance for electric current to reduce the risk of elec-

tric shock. This product is equipped with a cord having an equipment-grounding conductor and a grounding plug. **Plug the power cord into a surge suppressor, and plug the surge suppressor into an appropriate outlet that is properly installed and grounded in accordance with all local codes and ordinances. IMPORTANT: The treadmill is not compatible with GFCI-equipped outlets.**

This product is for use on a nominal 120-volt circuit, and has a grounding plug that looks like the plug illustrated in drawing 1 below. A temporary adapter that looks like the adapter illustrated in drawing 2 may be used to connect the surge suppressor to a 2-pole receptacle as shown in drawing 2 if a properly grounded outlet is not available.

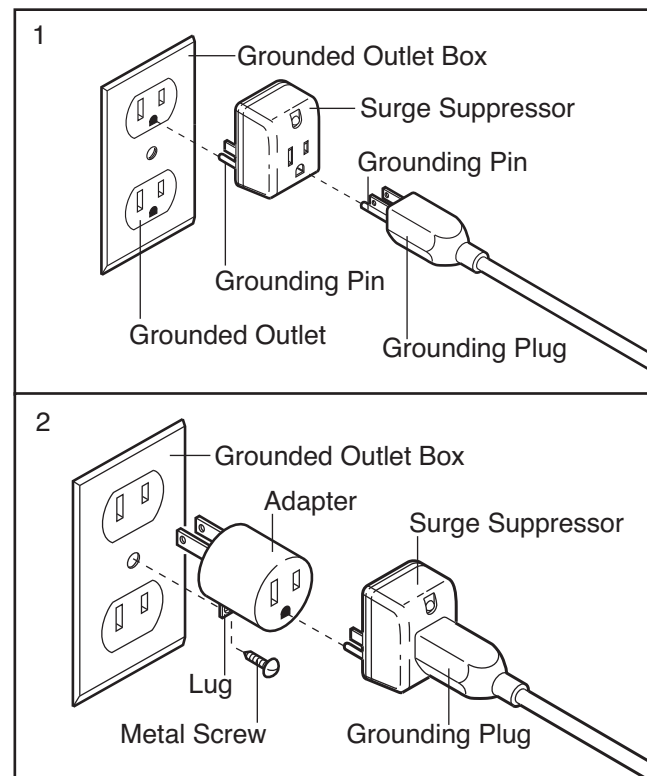

The temporary adapter should be used only until a properly grounded outlet (drawing 1) can be installed by a qualified electrician.

The green-colored rigid ear, lug, or the like extending from the adapter must be connected to a permanent ground such as a properly grounded outlet box cover. Whenever the adapter is used it must be held in place by a metal screw. **Some 2-pole receptacle outlet box covers are not grounded. Contact a qualified electrician to determine if the outlet box cover is grounded before using an adapter.**

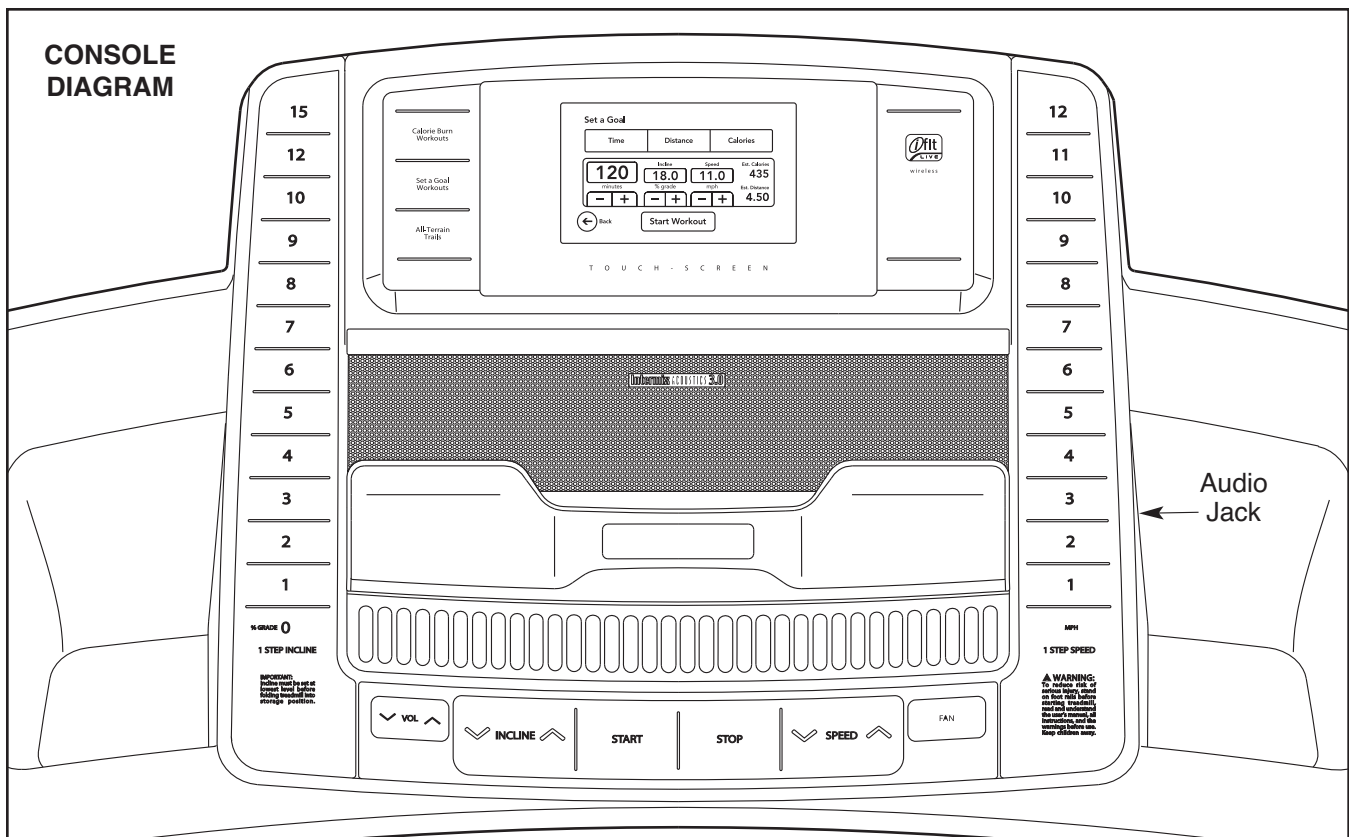

FEATURES OF THE CONSOLE

The treadmill console offers an impressive array of features designed to make your workouts more effective and enjoyable. When the manual mode of the console is selected, you can change the speed and incline of the treadmill with the touch of a button. As you exercise, the console will display continuous exercise feedback. You can even measure your heart rate using the handgrip pulse sensor.

The console also offers thirty preset workouts—twenty calorie burn workouts and ten all-terrain trails workouts. Each workout automatically controls the speed and incline of the treadmill as it guides you through an effective exercise session. In addition, you can set a time, distance, or calorie goal.

The console also features an iFit Live mode that enables the treadmill to communicate with your wireless network. With the iFit Live mode, you can download personalized workouts, create your own workouts, track your workout results, and access many other features. See www.iFit.com for complete information.

You can also listen to your favorite workout music or audio books with the console's premium stereo sound system while you get in shape.

To turn on the power, see page 14. **To use the manual mode**, see page 14. **To use a set-a-goal workout**, see page 17. **To use a calorie burn workout or an all-terrain trails workout**, see page 18. **To use the iFit Live mode**, see page 20. **To use the stereo sound system**, see page 21. **To use the settings mode**, see page 21. **To use the maintenance mode**, see page 23.

IMPORTANT: If there is a sheet of plastic on the face of the console, remove the plastic. To prevent damage to the walking platform, wear clean athletic shoes while using the treadmill. The first time the treadmill is used, observe the alignment of the walking belt, and center the walking belt if necessary (see page 28).

HOW TO TURN ON THE POWER

IMPORTANT: If the treadmill has been exposed to cold temperatures, allow it to warm to room temperature before turning on the power. If you do not do this, you may damage the console displays or other electrical components.

Plug in the power cord (see page 12). Next, locate the reset/off circuit breaker on the treadmill frame near the power cord. Make sure that the circuit breaker is in the reset position.

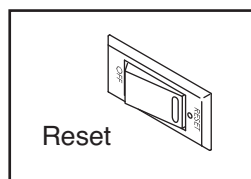

IMPORTANT: The console features a display demo mode, designed to be used if the treadmill is displayed in a store. If the demo mode is turned on, the displays will light a few seconds after you plug in the power cord and switch the reset/off circuit breaker to the reset position, before you insert the key. To turn off the demo mode, see step 4 on page 22.

Next, stand on the foot pads of the treadmill. Locate the clip attached to the key (see the drawing at the right), and slide the clip securely onto the waistband of your clothes.

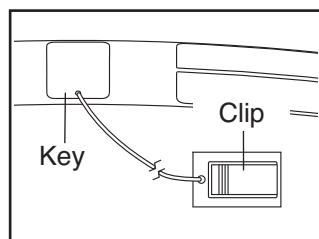

Then, insert the key into the console. After several seconds, the displays will light. **IMPORTANT:** In an emergency, the key can be pulled from the console, causing the walking belt to slow to a stop. Test the clip by carefully taking a few steps backward; if the key is not pulled from the console, adjust the position of the clip.

Before using the treadmill, please check for firmware updates (see step 7 on page 23).

Note: The console may be able to display speed and distance in either miles or kilometers. To find which unit of measurement is selected, see step 5 on page 22. For simplicity, all instructions in this manual refer to miles.

HOW TO USE THE MANUAL MODE

1. Insert the key into the console.

See HOW TO TURN ON THE POWER at the left. If necessary, press the Incline buttons to adjust the incline level to 0 percent. **Note:** It may take a minute for the console to be ready for use.

2. Select the start menu.

Each time the key is inserted, the start menu will appear. If you have selected a workout or the iFit Live mode, press the iFit Menu button in the upper right corner of the screen. Next, press the End Workout button, and then press the Done button to return to the start menu.

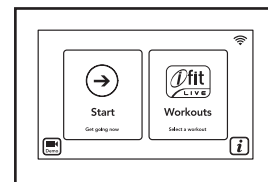

Note: A Demo button may appear in the lower left corner of the screen. If you press the Demo button, the treadmill will run a demo workout.

3. Start the walking belt and adjust the speed.

To start the walking belt, press the Start button on the screen or the Start button on the console. The walking belt will begin to move at 1 mph. As you exercise, change the speed of the walking belt as desired by pressing the Speed increase and decrease buttons. Each time you press one of the buttons, the speed setting will change by 0.1 mph; if you hold down the button, the speed setting will change in increments of 0.5 mph.

If you press one of the numbered speed buttons, the walking belt will gradually change speed until it reaches the selected speed setting. To select a speed setting that includes a decimal—such as 3.5 mph—press two numbered buttons in succession. For example, to select a speed setting of 3.5 mph, press the 3 button and then immediately press the 5 button.

To stop the walking belt, press the Stop button. To restart the walking belt, press the Start button.

4. Change the incline of the treadmill as desired.

To change the incline of the treadmill, press the Incline increase and decrease buttons or one of the Incline buttons numbered 0 to 15. Each time you press one of the buttons, the incline will gradually change until it reaches the selected incline setting.

5. Monitor your progress.

The console offers several display modes. The display mode that you select will determine which workout information is shown. To select the desired display mode, repeatedly press the Display increase or decrease button on the screen.

As you walk or run on the treadmill, the screen can show the following workout information:

- The elapsed time
- The approximate number of calories you have burned
- The distance that you have walked or run
- The incline level of the treadmill
- The speed of the walking belt
- A track representing 1/4 mile (400 meters)
- The time to complete one lap at the current speed setting
- Your current lap number
- The time remaining

- The approximate number of calories burned per hour
- The number of vertical feet you have climbed
- Your pace in minutes per mile
- Your heart rate (see step 6 on page 16)

The displays at the top of the screen can show two pieces of information. Press each display until the display shows the desired information. Note: The manual mode does not have a time remaining countdown.

If desired, adjust the volume level by pressing the Volume increase and decrease buttons on the console.

To reset the console, press the iFit Menu button in the upper right corner of the screen. To pause the workout, press the Pause button. To continue the workout, press the Resume button or the Start button. To end the workout and select a new workout, press the New Workout button. To end the workout, press the End Workout button.

Note: The small wireless symbol in the upper right corner of the screen will show your wireless connection status. If the symbol is yellow, your treadmill is connected to your wireless network. If the symbol is green, your treadmill is connected to your wireless network and you have logged in to www.iFit.com. If the symbol does not appear, you are not connected to your wireless network.

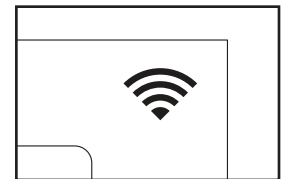

6. Measure your heart rate if desired.

Before using the handgrip pulse sensor, remove the sheets of plastic from the metal contacts, if necessary. In addition, make sure that your hands are clean.

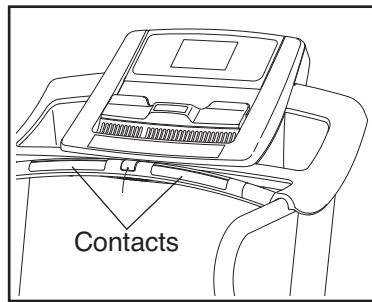

To measure your heart rate, **stand on the walking platform** and hold the metal contacts on the handrails for approximately ten seconds—**avoid moving your hands**. When your pulse is detected, your heart rate will be shown. **For the most accurate heart rate reading, continue to hold the contacts for about 15 seconds.**

7. Turn on the fan if desired.

The fan features three speed settings. Press the Fan button repeatedly to select a fan speed or to turn off the fan. You can also press the Fan increase and decrease buttons on the screen.

8. When you are finished exercising, remove the key from the console.

Step onto the foot pads and press the Stop button repeatedly until a workout summary appears on the screen. After you view the workout summary, press the Done button. Then, remove the key from the console and put it in a secure place.

When you are finished using the treadmill, switch the reset/off circuit breaker to the off position and unplug the power cord. **IMPORTANT: If you do not do this, the treadmill's electrical components may wear prematurely.**

HOW TO USE A SET-A-GOAL WORKOUT

1. Insert the key into the console.

See step 1 on page 14.

2. Select the start menu.

See step 2 on page 14.

3. Select a set-a-goal workout.

To select a set-a-goal workout, press the Workouts button on the screen. Then, press the Set a Goal button. You can also press the Set a Goal Workouts button on the console.

To set a time, distance, or calorie goal, press the Time, Distance, or Calories button. Then, press the increase and decrease buttons on the screen to select a time, distance, or calorie goal and to select the speed and incline for the workout. The screen will show the duration and distance of the workout, and the approximate number of calories you will burn during the workout.

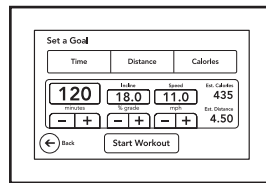

4. Start the workout.

Press the Start Workout button to start the workout. A moment after you press the button, the walking belt will begin to move. Hold the handrails and begin walking.

The workout will function in the same way as the manual mode (see pages 14 to 16).

The workout will continue until you reach the goal that you set. The walking belt will then slow to a stop, and a workout summary will appear on the screen. After you view the workout summary, press the Done button.

5. Monitor your progress.

See step 5 on page 15. The screen can also show your goal and a status bar showing your progress toward your goal.

6. Measure your heart rate if desired.

See step 6 on page 16.

7. Turn on the fan if desired.

See step 7 on page 16.

8. When you are finished exercising, remove the key from the console.

See step 8 on page 16.

HOW TO USE A CALORIE BURN WORKOUT OR AN ALL-TERRAIN TRAILS WORKOUT

1. Insert the key into the console.

See step 1 on page 14.

2. Select the start menu.

See step 2 on page 14.

3. Select a calorie burn workout or an all-terrain trails workout.

To select a calorie burn workout or an all-terrain trails workout, press the Workouts button on the screen. Then, press the Calorie Burn button or the All-Terrain Trails button. You can also press the Calorie Burn Workouts button or the All-Terrain Trails button on the console.

To select a calorie burn workout, select the desired difficulty level. Then, select the desired workout. The screen will show the approximate number of calories you will burn during the workout. The screen will also show the duration and distance of your workout. In addition, the screen will show the number of vertical feet you will climb and a profile of the incline settings of the workout.

To select an all-terrain trails workout, select the desired difficulty level. Then, select the desired workout. The screen will show the duration of the workout and the approximate number of calories you will burn during the workout. The screen will

also show the distance of your workout and the number of vertical feet you will climb. In addition, the screen will show a topographic map of the trail. Press the Profile button at the top of the screen near the time display to view a profile of the incline settings of the workout. To return to the map, press the Trail button at the top of the screen.

4. Start the workout.

Press the Start Workout button to start the workout. A moment after you press the button, the walking belt will begin to move. Hold the handrails and begin walking.

Each workout is divided into segments. One speed setting and one incline setting are programmed for each segment. Note: The same speed setting and/or incline setting may be programmed for consecutive segments.

During the workout, the profile will show your progress. Press the Display increase and decrease buttons repeatedly to view the profile. The red line will indicate the current segment of the workout. The height of the current segment indicates the incline setting for the current segment.

At the end of the first segment of the workout, a series of tones will sound. If a different speed and/or incline setting is programmed for the second segment, the speed setting and/or incline setting will flash on the screen for a moment to alert you. The treadmill will then automatically adjust to the speed and/or incline settings for the next segment.

The workout will continue in this way until the last segment ends. The walking belt will then slow to a stop, and a workout summary will appear on the screen. After you view the workout summary, press the Done button.

If the speed or incline setting is too high or too low at any time during the workout, you can override the setting by pressing the Speed or Incline buttons; **however, when the next segment begins, the treadmill will automatically adjust to the speed and incline settings for the next segment.**

To stop the workout at any time, press the iFit Menu button in the upper right corner of the screen. To pause the workout, press the Pause button. To end the workout and select a new workout, press the New Workout button. To end the workout, press the End Workout button.

To continue the workout, press the Resume button or the Start button. The walking belt will begin to move at 1 mph. When the next segment of the workout begins, the treadmill will automatically adjust to the speed and incline settings for the next segment.

Note: The calorie goal is an estimate of the number of calories that you will burn during the

workout. The actual number of calories that you burn will depend on your weight. In addition, if you manually change the speed or incline of the treadmill during the workout, the number of calories you burn will be affected.

5. Monitor your progress.

See step 5 on page 15. The screen can also show a profile of the incline settings of the workout. When an all-terrain trails workout is selected, the screen can show a topographic map of the trail. The person running on the trail indicates your progress.

6. Measure your heart rate if desired.

See step 6 on page 16.

7. Turn on the fan if desired.

See step 7 on page 16.

8. When you are finished exercising, remove the key from the console.

See step 8 on page 16.

HOW TO USE THE iFIT LIVE MODE

The iFit Live mode enables the treadmill to communicate with your wireless network. With the iFit Live mode, you can download personalized workouts, create your own workouts, track your workout results, and access many other features. See www.iFit.com for complete information.

1. Connect your treadmill to your own wireless network.

See steps 1 and 2 on pages 21 and 22.

To activate and use the iFit Live mode, you must have your own wireless network. You must have an 802.11b router with SSID broadcast enabled (hidden networks are not supported). You will also need an iFit.com membership.

2. Select the iFit Live mode.

To select the iFit Live mode, first select the start menu (see step 2 on page 14). Next, press the Workouts button and then press the Live Workouts button.

To set up an iFit Live account, or for more information about the iFit Live mode, go to www.iFit.com.

To switch users, press the Switch User button in the lower right corner of the screen. Then, select the desired user.

IMPORTANT: To comply with FCC and IC RF exposure compliance requirements, the antenna used for this transmitter must be installed to provide a separation distance of at least 20 cm from all persons and must not be co-located or operating in conjunction with any other antenna or transmitter.

This equipment has been tested and found to comply with the limits for a Class B digital device, pursuant to

Part 15 of the FCC Rules. These limits are designed to provide reasonable protection against harmful interference in a residential installation. This equipment generates, uses, and can radiate radio frequency energy and, if not installed and used in accordance with the instructions, may cause harmful interference to radio communications. However, there is no guarantee that interference will not occur in a particular installation. If this equipment does cause harmful interference to radio or television reception, which can be determined by turning the equipment off and on, the user is encouraged to try to correct the interference by one of the following measures:

- Reorient or relocate the receiving antenna.
- Increase the separation between the equipment and the receiver.
- Connect the equipment into an outlet on a circuit different from that to which the receiver is connected.
- Consult the dealer or an experienced radio/TV technician for help.

FCC CAUTION: To assure continued compliance, use only shielded interface cables when connecting to computer or peripheral devices. Any changes or modifications not expressly approved by the party responsible for compliance could void the user's authority to operate this equipment.

This device complies with Part 15 of the FCC Rules. Operation is subject to the following two conditions: (1) This device may not cause harmful interference, and (2) this device must accept any interference received, including interference that may cause undesired operation.

If you have questions after reading this information, please call Customer Care toll-free at 1-866-608-1798, Mon.–Fri. 6 am–6 pm MT, Sat. 8 am–4 pm MT (closed on holidays); visit www.iFit.com/support; or send e-mail to service@iconfitness.com.

HOW TO USE THE STEREO SOUND SYSTEM

To play music or audio books through the console's speakers, you must connect your MP3 player, CD player, or other personal audio player to the console.

Locate the audio wire. Plug one end into the audio jack on the side of the console. Plug the other end into a jack on your MP3 player, CD player, or other personal audio player. **Make sure that the audio wire is fully plugged in.**

Next, press the Play button on your MP3 player, CD player, or other personal audio player. Then, adjust the volume level on your personal audio player or press the Vol increase and decrease buttons on the console.

If you are using a personal CD player and the CD skips, set the CD player on the floor or another flat surface instead of on the console.

HOW TO USE THE SETTINGS MODE

The console features a settings mode that allows you to connect your treadmill to your own wireless network and to log in to your iFit Live account. The settings mode also allows you to turn on and turn off the display demo mode. You may also be able to select the unit of measurement.

1. Select the settings mode.

Insert the key into the console (see step 1 on page 14). Next, select the start menu (see step 2 on page 14). Then, press the **i** button in the lower right corner of the screen to select the settings mode.

2. Select the wireless network mode.

Press the Wireless Network button on the screen.

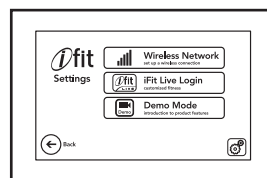

You must have your own wireless network and an 802.11b router with SSID broadcast enabled (hidden networks are not supported).

If your wireless network is unencrypted and does not require a password, go to step 2a. If your wireless network is encrypted and requires a password, go to step 2b.

2a. Connect your treadmill to an unencrypted wireless network.

Select the desired wireless network and press the Connect button. When the Disconnect button appears, your exercise equipment is connected to the wireless network. Then, press the Done button. Go to step 3.

2b. Connect your treadmill to an encrypted wireless network.

To connect to your encrypted network, you will need to know your network SSID (network name), network encryption type, and network password.

Select the desired wireless network and press the Advanced button. If your network is encrypted, you must press the Use Encryption button and fill in the entry boxes. If desired, you may also set a static IP address and/or a static domain name server (DNS).

To use encryption, press the Use Encryption button. Select the encryption type and enter the password. When you are finished, press the Submit button. To return to the advanced settings screen, press the Cancel button.

To use numbers or other characters on the keyboard on the screen, press the .?123 button or the #+= button. To return to the letter keyboard, press the ABC button. To capitalize a character, press the button with an upward-facing arrow. To clear the last character, press the button with a backward-facing arrow and an X.

To use a static IP address, press the Use Static IPs button. Enter the IP address, netmask, gateway IP address, and at least one DNS. Press the arrow buttons to view additional entry boxes. When you are finished, press the Submit button. To return to the advanced settings screen, press the Cancel button.

To use a static DNS, press the Use Static DNS button. Enter at least one DNS. Press the arrow buttons to view additional entry boxes. When you are finished, press the Submit button. To return to the advanced settings screen, press the Cancel button.

If necessary, press the Cancel button to exit the advanced settings screen.

If you are having problems connecting, unencrypt your network, update your console firmware (see step 7 on page 23), and then encrypt your network.

Note: If you turn on encryption on a non-encrypted network, the console will not function correctly.

Note: The iFit Live mode supports unsecured and secured (WEP, WPA, and WPA2) encryption. A broadband connection is recommended; performance depends on connection speed.

Note: If you have questions after following these instructions, go to www.iFit.com/support for assistance.

3. Log in to your iFit Live account.

Press the iFit Live Login button. Then, enter your user name and password using the keyboard on the screen. To use numbers or other characters, press the **.?123** button or the **#+=** button. To return

to the letter keyboard, press the ABC button. To capitalize a character, press the button with an upward-facing arrow. To clear the last character, press the button with a backward-facing arrow and an X. When you are finished, press the Login button. To return to the settings mode, press the Cancel button.

To set up an iFit Live account, or for more information about the account, go to www.iFit.com.

4. Turn on or turn off the display demo mode.

The console features a display demo mode, designed to be used if the treadmill is displayed in a store. While the demo mode is turned on, the console will function normally when you plug in the power cord, switch the reset/off circuit breaker to the reset position, and insert the key into the console. However, when you remove the key, the screen will remain lit, although the buttons will not function.

To turn on or turn off the display demo mode, first press the Demo Mode button. Next, press the On button or the Off button. Then, press the Back button.

5. View the unit of measurement.

Press the US/Metric button to view the selected unit of measurement. Change the unit of measurement, if desired. Then, press the Back button.

Note: If you purchased your treadmill in the US, the US/Metric button may not be enabled.

6. Exit the settings mode.

To exit the settings mode, press the Back button.

HOW TO USE THE MAINTENANCE MODE

The console features a maintenance mode that allows you to calibrate the incline and speed of the treadmill, restore factory defaults, calibrate the screen, update the console firmware, and view technical information.

1. Select the settings mode.

See step 1 on page 21.

2. Select the maintenance mode.

Press the Maintenance button in the lower right corner of the screen to enter the maintenance mode.

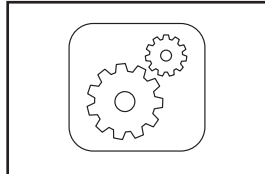

3. Calibrate the incline system of the treadmill.

Press the Calibrate Incline button. The treadmill will automatically rise to the maximum incline level, lower to the minimum incline level and then return to the starting position. This will recalibrate the incline system. Press the Begin button to calibrate the incline or the Cancel button to return to the maintenance mode. When the incline system is calibrated, press the Back button.

IMPORTANT: Keep pets, feet, and other objects away from the treadmill while the incline is calibrating. In an emergency, pull the key from the console to stop the incline calibration.

4. Restore factory defaults.

If necessary, press the Restore Defaults button to reset the firmware to the original factory firmware. This will erase all firmware updates that you have downloaded. Press the Begin button to restore the default firmware or the Cancel button to return to the maintenance mode.

When the restoration is complete, the words PLEASE CYCLE POWER will appear in the grey box. Switch the reset/off circuit breaker to the off position. Wait for several seconds, and then switch the circuit breaker to the reset position. It may take a minute for the console to be ready for use.

5. Calibrate the screen.

If the screen is not properly calibrated, it will be difficult to press the buttons on the screen. To calibrate the screen, press the Calibrate Screen button and then press the Begin button. Press the Cancel button to return to the maintenance mode.

Using a pencil eraser or other small object, press the center of the small target on the screen. Then, press the next two targets.

6. Calibrate the speed of the treadmill.

Calibrate the speed of the treadmill only if instructed to do so by an authorized service representative.

Note: The Calibrate Speed button may not be enabled on your treadmill.

7. Update the console firmware.

For the best results, regularly check for firmware updates.

Press the Firmware Update button. Press the Begin button to check for updates or the Cancel button to return to the maintenance mode.

A status bar will appear in the grey box on your screen. When the update is complete, the words PLEASE CYCLE POWER will appear in the grey box. Switch the reset/off circuit breaker to the off position. Wait for several seconds, and then switch the circuit breaker to the reset position. It may take a minute for the console to be ready for use.

8. View technical information.

Press the Technical Info button to view the total number of hours that the treadmill has been used and the total number of miles that the walking belt has moved. When you are done viewing the information, press the Finish button.

9. Exit the maintenance mode.

To exit the maintenance mode, press the Back button repeatedly.

HOW TO FOLD AND MOVE THE TREADMILL

HOW TO FOLD THE TREADMILL

To avoid damaging the treadmill, adjust the incline to the lowest position before you fold the treadmill. Then, remove the key and unplug the power cord. **CAUTION:** You must be able to safely lift 45 lbs. (20 kg) to raise, lower, or move the treadmill.

1. Hold the walking platform firmly in the location shown by the arrow below. **CAUTION: Do not hold the treadmill by the plastic parts. Make sure to bend your legs and keep your back straight.** Raise the walking platform about halfway to the vertical position.

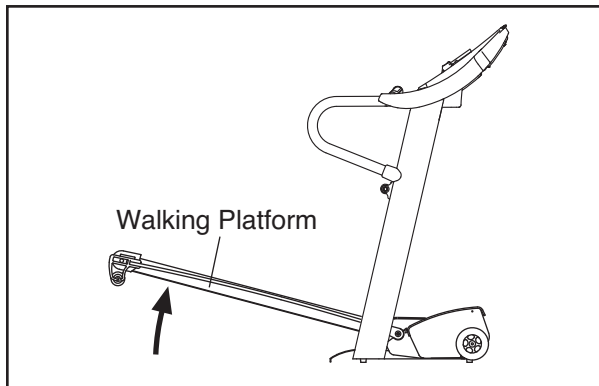

2. Hold the walking platform firmly with your right hand. Pull the latch knob to the left and hold it. Raise the walking platform until the plate passes the pin on the latch knob. Release the latch knob. **Make sure that the plate is resting against the pin as shown.**

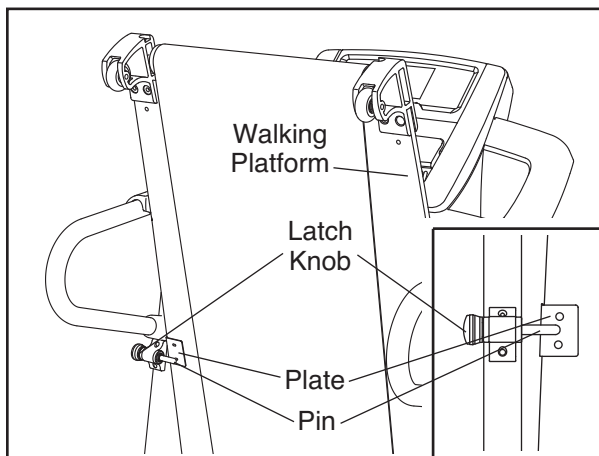

To protect the floor or carpet, place a mat under the treadmill. Keep the treadmill out of direct sunlight. Do not leave the treadmill in the storage position in temperatures above 85° F (30° C).

HOW TO MOVE THE TREADMILL

Before moving the treadmill, fold it as described at the left. **CAUTION: Make sure that the plate is resting against the pin. Moving the treadmill may require two people.**

1. Hold the uprights and place one foot against a wheel.

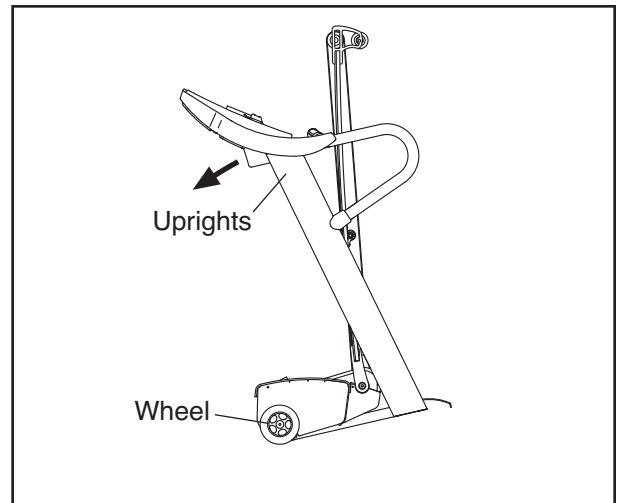

2. Pull back on the uprights until the treadmill will roll on the wheels, and carefully move it to the desired location. **CAUTION: Do not move the treadmill without tipping it back and do not move the treadmill over an uneven surface.**
3. Place one foot against a wheel, and carefully lower the treadmill.

HOW TO LOWER THE TREADMILL FOR USE

1. Hold the upper end of the treadmill with your right hand. Pull the latch knob to the left; if necessary, push the walking platform forward slightly. Pivot the walking platform downward a few inches, and release the latch knob.

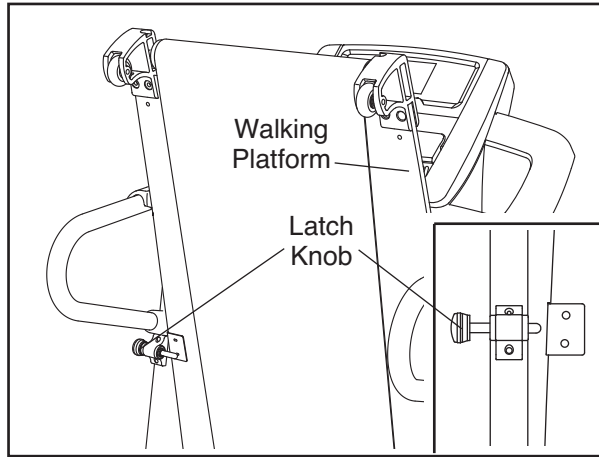

2. Hold the walking platform firmly with both hands, and lower it to the floor. **CAUTION: Do not hold the walking platform by the plastic parts, and do not drop the walking platform. Make sure to bend your legs and keep your back straight.**

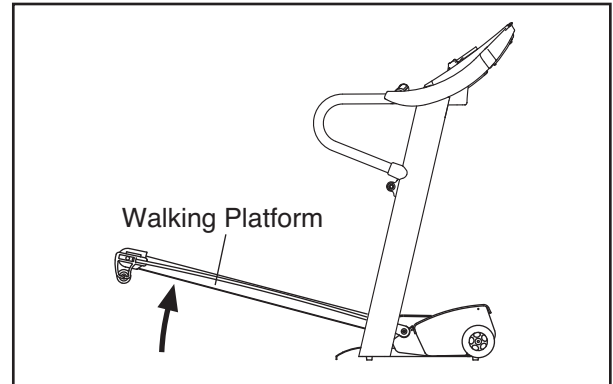

TROUBLESHOOTING

Most treadmill problems can be solved by following the steps below. Find the symptom that applies, and follow the steps listed. If further assistance is needed, see the front cover of this manual.

PROBLEM: The power does not turn on

SOLUTION: a. Make sure that the power cord is plugged into a surge suppressor, and that the surge suppressor is plugged into a properly grounded outlet (see page 12). Use only a single-outlet surge suppressor that meets all of the specifications described on page 12. **IMPORTANT: The treadmill is not compatible with GFCI-equipped outlets.**

b. After the power cord has been plugged in, make sure that the key is fully inserted into the console.

c. Check the reset/off circuit breaker located on the treadmill frame near the power cord. If the switch protrudes as shown, the circuit breaker has tripped. To reset the circuit breaker, wait for five minutes and then press the switch to the reset position.

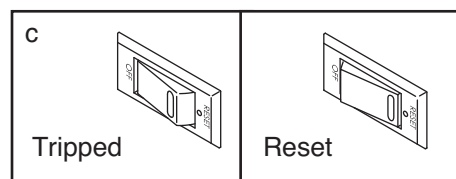

PROBLEM: The power turns off during use

SOLUTION: a. Check the reset/off circuit breaker (see the drawing above). If the circuit breaker has tripped, wait for five minutes and then press the switch to the reset position.

b. Make sure that the power cord is plugged in. If the power cord is plugged in, unplug it, wait for five minutes, and then plug it back in.

c. Remove the key from the console. Reinsert the key fully into the console.

d. If the treadmill still will not run, see the front cover of this manual.

PROBLEM: The console screen remains lit when you remove the key from the console

SOLUTION: a. The console features a display demo mode, designed to be used if the treadmill is displayed in a store. If the screen remains lit when you remove the key, the demo mode is turned on. To turn off the demo mode, see step 4 on page 22.

PROBLEM: The console does not display speed and distance correctly

SOLUTION: a. Remove the key from the console and **unplug the power cord**. Next, remove the #8 x 3/4" Hood Screws (6) from the Motor Hood (73) and pivot the Motor Hood off.

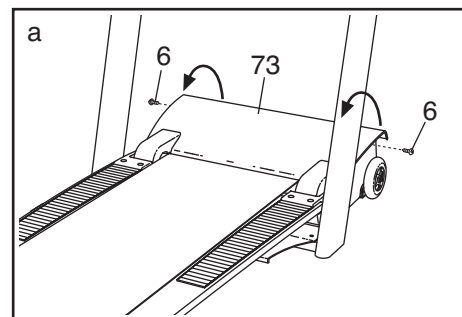

Locate the Reed Switch (71) and the Magnet (50) on the left side of the Pulley (53). Turn the Pulley until the Magnet is aligned with the Reed Switch. **Make sure that the gap between the Magnet and the Reed Switch is about 1/8 in. (3 mm).** If necessary, loosen the #8 x 3/4" Washer Head Tek Screw (9), move the Reed Switch slightly, and then retighten the Screw. Reattach the Motor Hood (not shown) and run the treadmill for a few minutes to check for a correct speed reading.

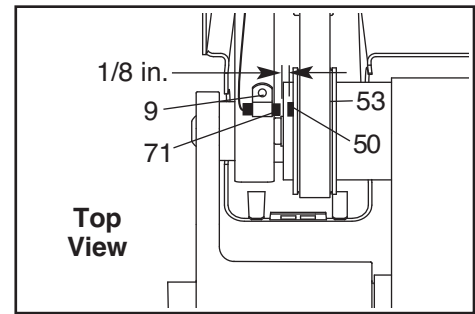

PROBLEM: The incline of the treadmill does not change correctly

SOLUTION: a. Recalibrate the incline system (see step 3 on page 23).

PROBLEM: The iFit Live mode is not functioning correctly

SOLUTION: a. If the iFit Live mode is not functioning correctly, make sure that the treadmill has the most current firmware available (see step 7 on page 23).

PROBLEM: The walking belt slows when walked on

SOLUTION: a. Use only a single-outlet surge suppressor that meets all of the specifications described on page 12.

b. If the walking belt is overtightened, treadmill performance may decrease and the walking belt may become damaged. Remove the key and **UNPLUG THE POWER CORD**. Using the hex key, turn both idler roller bolts counterclockwise, 1/4 of a turn. When the walking belt is properly tightened, you should be able to lift each edge of the walking belt 3 to 4 in. (8 to 10 cm) off the walking platform. Be careful to keep the walking belt centered. Then, plug in the power cord, insert the key, and run the treadmill for a few minutes. Repeat until the walking belt is properly tightened.

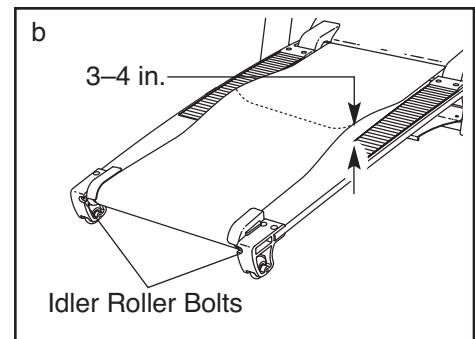

c. If the walking belt still slows when walked on, see the front cover of this manual.

PROBLEM: The walking belt is off-center or slips when walked on

SOLUTION: a. If the walking belt is off-center, remove the key and **UNPLUG THE POWER CORD**. If the walking belt has shifted to the left, use the hex key to turn the left idler roller bolt clockwise 1/2 of a turn; if the walking belt has shifted to the right, turn the left idler roller bolt counterclockwise 1/2 of a turn. Be careful not to overtighten the walking belt. Then, plug in the power cord, insert the key, and run the treadmill for a few minutes. Repeat until the walking belt is centered.

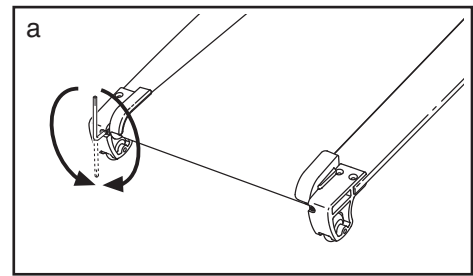

b. If the walking belt slips when walked on, first remove the key and **UNPLUG THE POWER CORD**. Using the hex key, turn both idler roller bolts clockwise, 1/4 of a turn. When the walking belt is correctly tightened, you should be able to lift each edge of the walking belt 3 to 4 in. (8 to 10 cm) off the walking platform. Be careful to keep the walking belt centered. Plug in the power cord, insert the key, and carefully walk on the treadmill for a few minutes. Repeat until the walking belt is properly tightened.

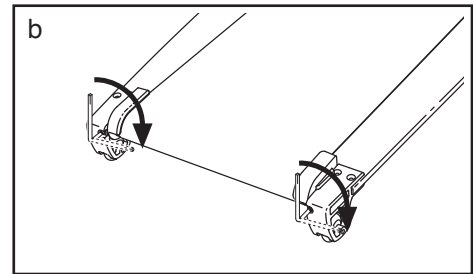

EXERCISE GUIDELINES

⚠ WARNING: Before beginning any exercise program, consult your physician. This is especially important for persons over age 35 or persons with pre-existing health problems.

The pulse sensor is not a medical device. Various factors may affect the accuracy of heart rate readings. The pulse sensor is intended only as an exercise aid in determining heart rate trends in general.

These guidelines will help you to plan your exercise program. For detailed exercise information, obtain a reputable book or consult your physician. Remember, proper nutrition and adequate rest are essential for successful results.

EXERCISE INTENSITY

Whether your goal is to burn fat or to strengthen your cardiovascular system, exercising at the proper intensity is the key to achieving results. You can use your heart rate as a guide to find the proper intensity level. The chart below shows recommended heart rates for fat burning and aerobic exercise.

165	155	145	140	130	125	115	♥
145	138	130	125	118	110	103	♥
125	120	115	110	105	95	90	♥
<hr/>							
20	30	40	50	60	70	80	

To find the proper intensity level, find your age at the bottom of the chart (ages are rounded off to the nearest ten years). The three numbers listed above your age define your “training zone.” The lowest number is the heart rate for fat burning, the middle number is the heart rate for maximum fat burning, and the highest number is the heart rate for aerobic exercise.

Burning Fat—To burn fat effectively, you must exercise at a low intensity level for a sustained period of time. During the first few minutes of exercise, your body uses *carbohydrate calories* for energy. Only after the first few minutes of exercise does your body begin to use stored *fat calories* for energy. If your goal is to burn fat, adjust the intensity of your exercise until your heart rate is near the lowest number in your training zone. For maximum fat burning, exercise with your heart rate near the middle number in your training zone.

Aerobic Exercise—If your goal is to strengthen your cardiovascular system, you must perform aerobic exercise, which is activity that requires large amounts of oxygen for prolonged periods of time. For aerobic exercise, adjust the intensity of your exercise until your heart rate is near the highest number in your training zone.

WORKOUT GUIDELINES

Warming Up—Start with 5 to 10 minutes of stretching and light exercise. A warm-up increases your body temperature, heart rate, and circulation in preparation for exercise.

Training Zone Exercise—Exercise for 20 to 30 minutes with your heart rate in your training zone. (During the first few weeks of your exercise program, do not keep your heart rate in your training zone for longer than 20 minutes.) Breathe regularly and deeply as you exercise—never hold your breath.

Cooling Down—Finish with 5 to 10 minutes of stretching. Stretching increases the flexibility of your muscles and helps to prevent post-exercise problems.

EXERCISE FREQUENCY

To maintain or improve your condition, complete three workouts each week, with at least one day of rest between workouts. After a few months of regular exercise, you may complete up to five workouts each week, if desired. Remember, the key to success is to make exercise a regular and enjoyable part of your everyday life.

PART LIST—Model No. NTL11909.0

R0410A

To locate the parts listed below, see the EXPLODED DRAWING near the end of this manual.

Key No.	Qty.	Description	Key No.	Qty.	Description
1	4	#8 x 1" Tek Screw	51	1	Left Foot Pad
2	6	5/16" x 3/4" Patch Bolt	52	1	Drive Roller Ground Wire
3	2	3/8" x 2" Bolt	53	1	Drive Roller/Pulley
4	4	5/16" Star Washer	54	1	Walking Belt
5	3	#8 x 1/2" Screw	55	1	Console Ground Wire
6	2	#8 x 3/4" Hood Screw	56	1	Front Right Cap
7	8	5/16" x 2" Bolt	57	2	Releasable Tie
8	2	Idler Roller Bolt	58	1	Plastic Washer
9	11	#8 x 3/4" Washer Head Tek Screw	59	8	Plastic Tie
10	1	1/4" x 2" Bolt	60	9	Plastic Clamp
11	15	#8 x 1/2" Electronics Screw	61	1	Right Foot Pad
12	43	#8 x 3/4" Screw	62	1	Walking Platform
13	1	Audio Wire	63	1	Idler Roller
14	1	3/8" x 3 1/2" Bolt	64	2	Rear Wheel
15	1	3/8" x 2" Hex Bolt	65	1	Right Rear Foot
16	1	3/8" x 1 1/4" Bolt	66	1	Right Idler Roller Guard
17	1	3/8" x 1 1/2" Bolt	67	1	Left Idler Roller Guard
18	4	#8 x 3/4" Bracket Screw	68	1	Left Rear Foot
19	2	Motor Bolt	69	1	Warning Decal
20	2	3/8" x 3 1/4" Bolt	70	1	Idler Arm
21	2	3/8" x 2 1/2" Bolt	71	1	Reed Switch
22	2	3/8" x 2 3/8" Bolt	72	1	Reed Switch Clamp
23	2	3/8" Flat Washer	73	1	Motor Hood
24	8	5/16" Flat Washer	74	1	Controller
25	2	1/2" Pivot Washer	75	1	Electronics Plate
26	2	1/4" Roller Star Washer	76	1	Incline Stop Bracket
27	2	1/2" Thrust Washer	77	1	Motor Belt
28	2	1/4" x 1/2" Patch Bolt	78	1	Drive Motor
29	1	Idler Arm Pulley	79	1	Incline Motor
30	2	Spring Washer	80	1	Belly Pan
31	1	Belly Pan Support Bracket	81	1	Reset/Off Circuit Breaker
32	9	3/8" Nut	82	1	Power Cord
33	8	5/16" Nut	83	1	Power Cord Grommet
34	2	Hood Clip	84	1	Hole Plug
35	2	1/2" Plastic Washer	85	1	Belly Pan Grommet
36	1	Idler Arm Washer	86	1	Support Bracket
37	4	Front Wheel Spacer	87	1	Lift Frame
38	3	Hood Mount	88	1	Latch Assembly
39	2	Side Hood Mount	89	1	Latch Housing
40	2	Idler Roller Spring	90	2	Wheel
41	1	Idler Arm Spring	91	2	Wheel Bushing
42	1	Hex Key	92	2	Wheel Spacer
43	1	Upright	93	1	Upright Wire
44	1	Pulse Crossbar	94	2	Base Cap
45	2	Pulse Bar Ground Wire	95	1	Base Ground Wire
46	1	#8 Star Washer	96	4	Base Foot
47	1	Front Left Cap	97	1	Base Plate
48	2	Belt Guide	98	1	Base Plate Edging
49	1	Latch Plate	99	2	5/16" Cage Nut
50	1	Magnet	100	2	Cage Nut

Key No.	Qty.	Description	Key No.	Qty.	Description
101	1	Left Handrail	111	1	Right Accessory Tray
102	1	Right Handrail	112	1	Filter
103	2	Handrail Cover	113	1	Access Door
104	2	Console Clamp	114	1	Pulse Bar
105	1	Ground Wire	115	4	#8 x 1" Screw
106	1	Key/Clip	116	2	1/4" Star Washer
107	8	Wire Clamp	117	4	#10 x 1/2" Screw
108	1	Console	118	1	PC Power Supply
109	1	Console Base	*	–	User's Manual
110	1	Left Accessory Tray			

Note: Specifications are subject to change without notice. For information about ordering replacement parts, see the back cover of this manual. *These parts are not illustrated.

EXPLODED DRAWING A—Model No. NTL11909.0

R0410A

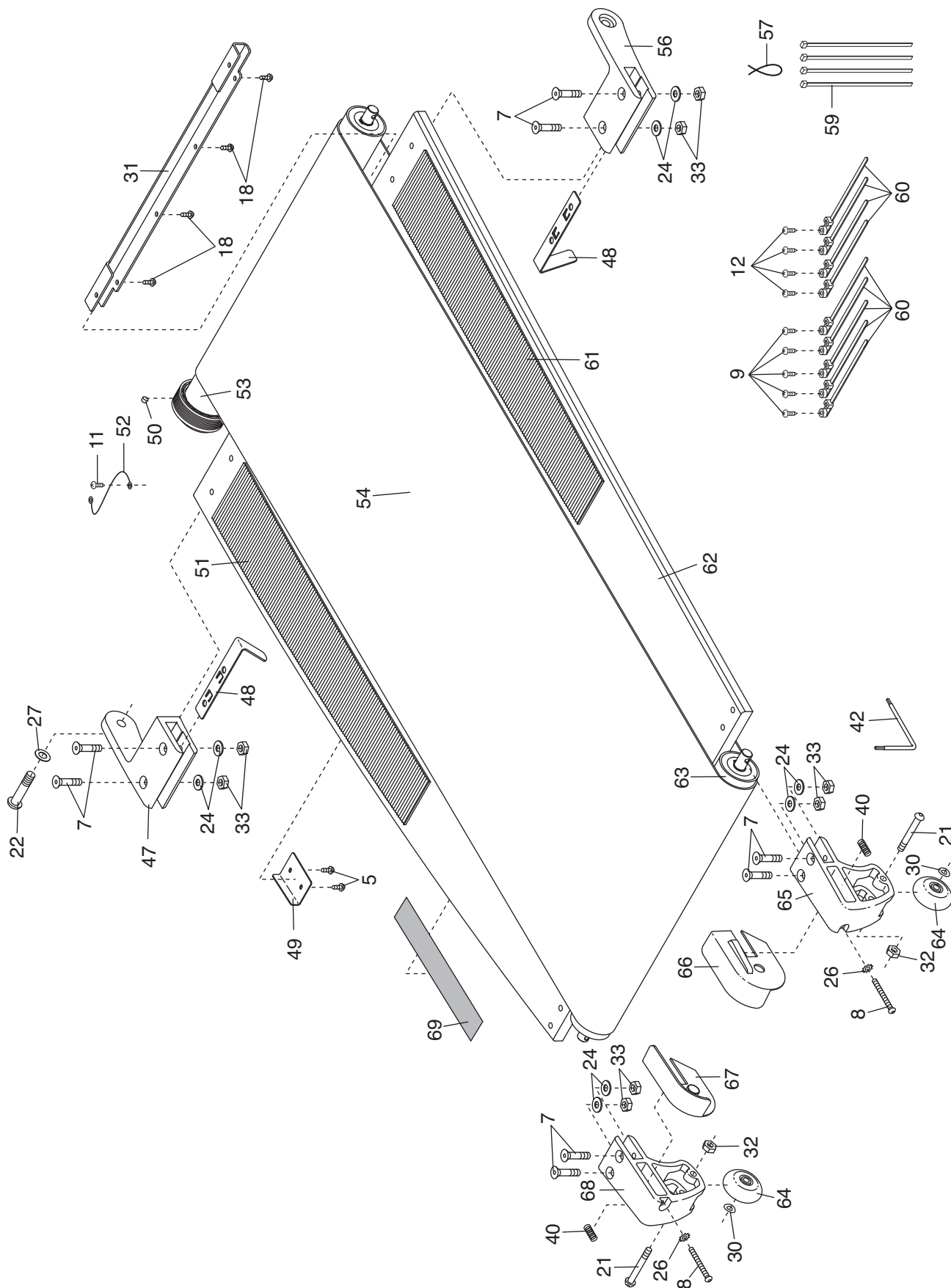

EXPLODED DRAWING B—Model No. NTL11909.0

R0410A

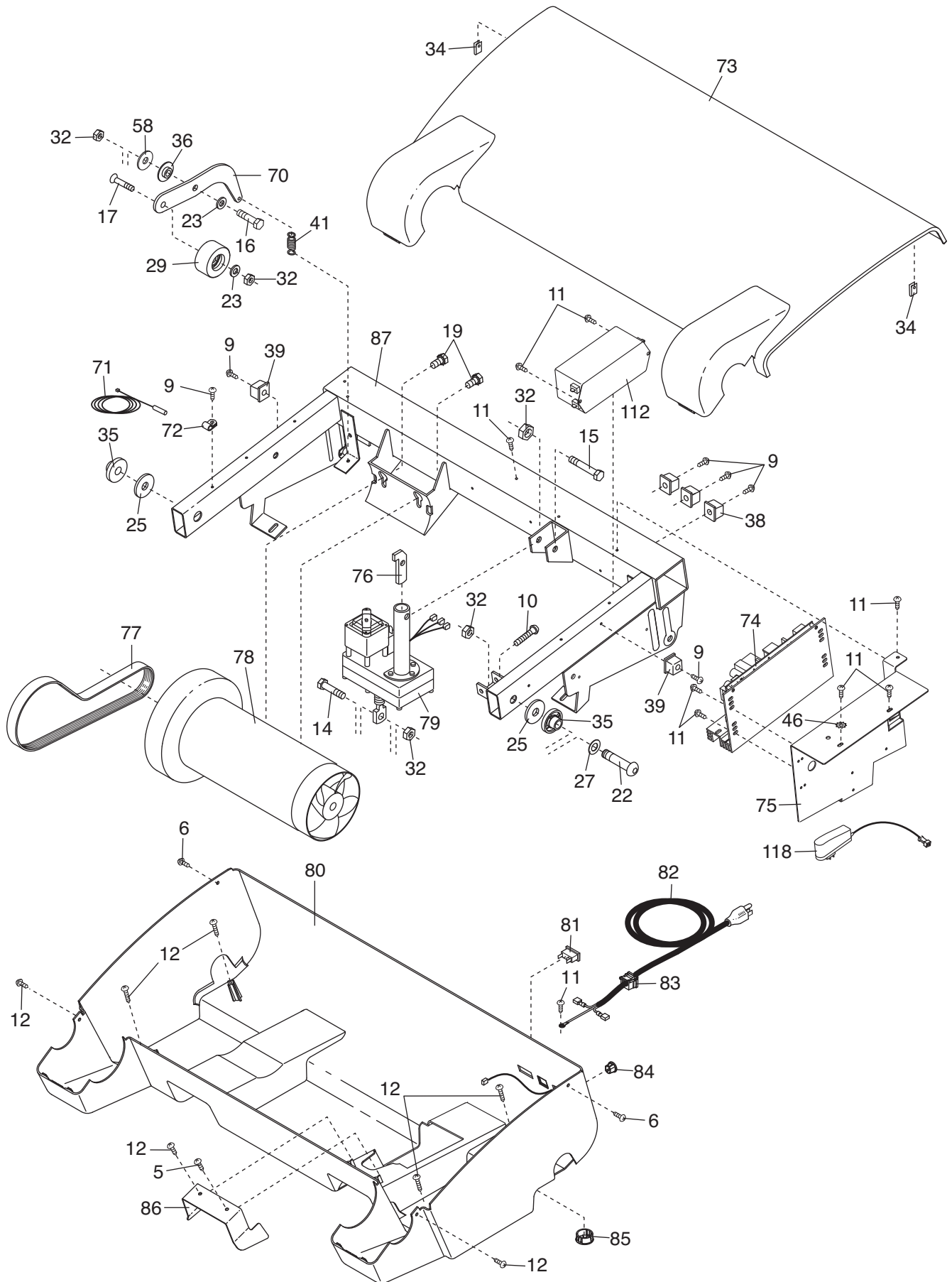

EXPLODED DRAWING C—Model No. NTL11909.0

R0410A

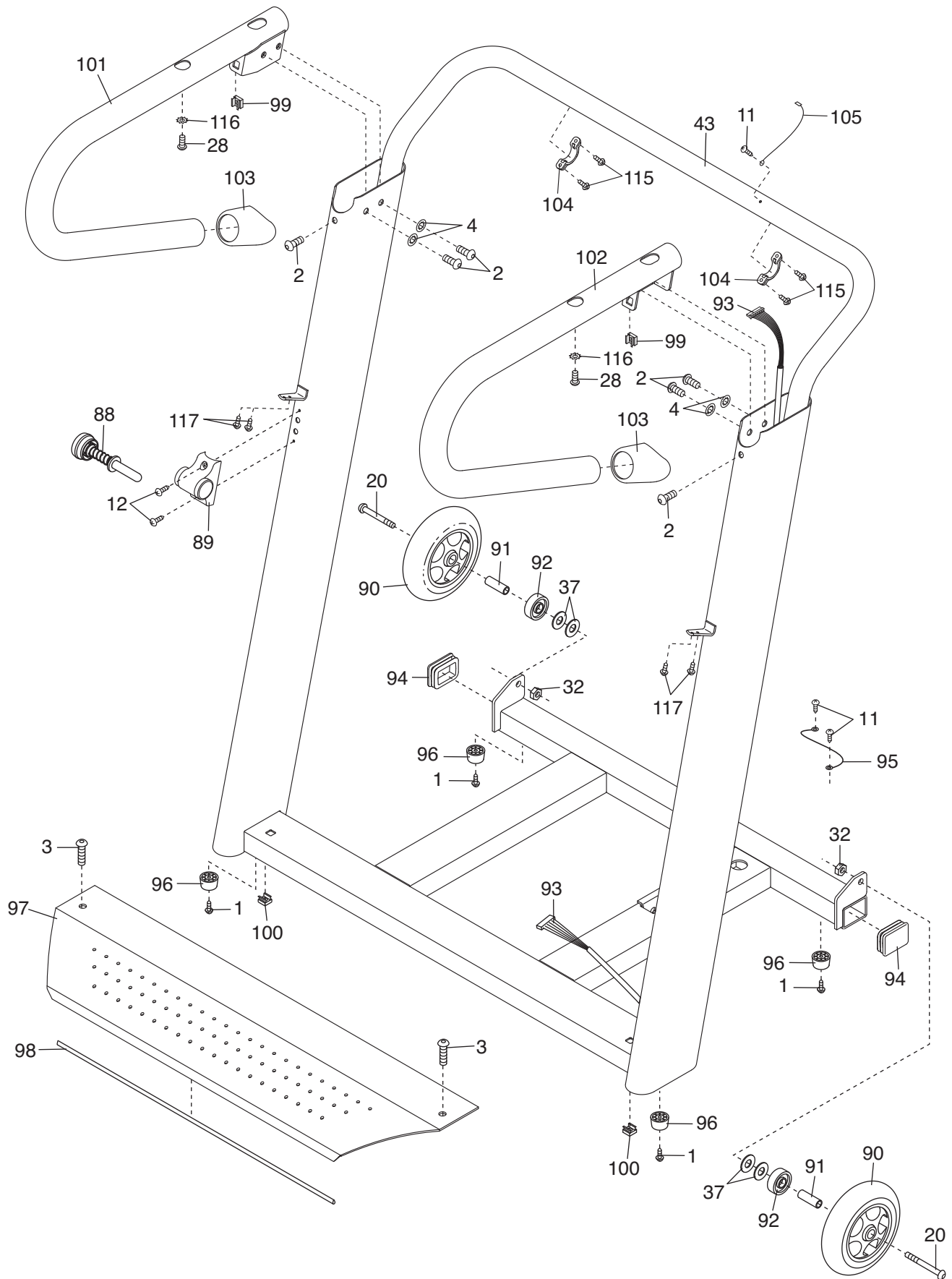

EXPLODED DRAWING D—Model No. NTL11909.0

R0410A

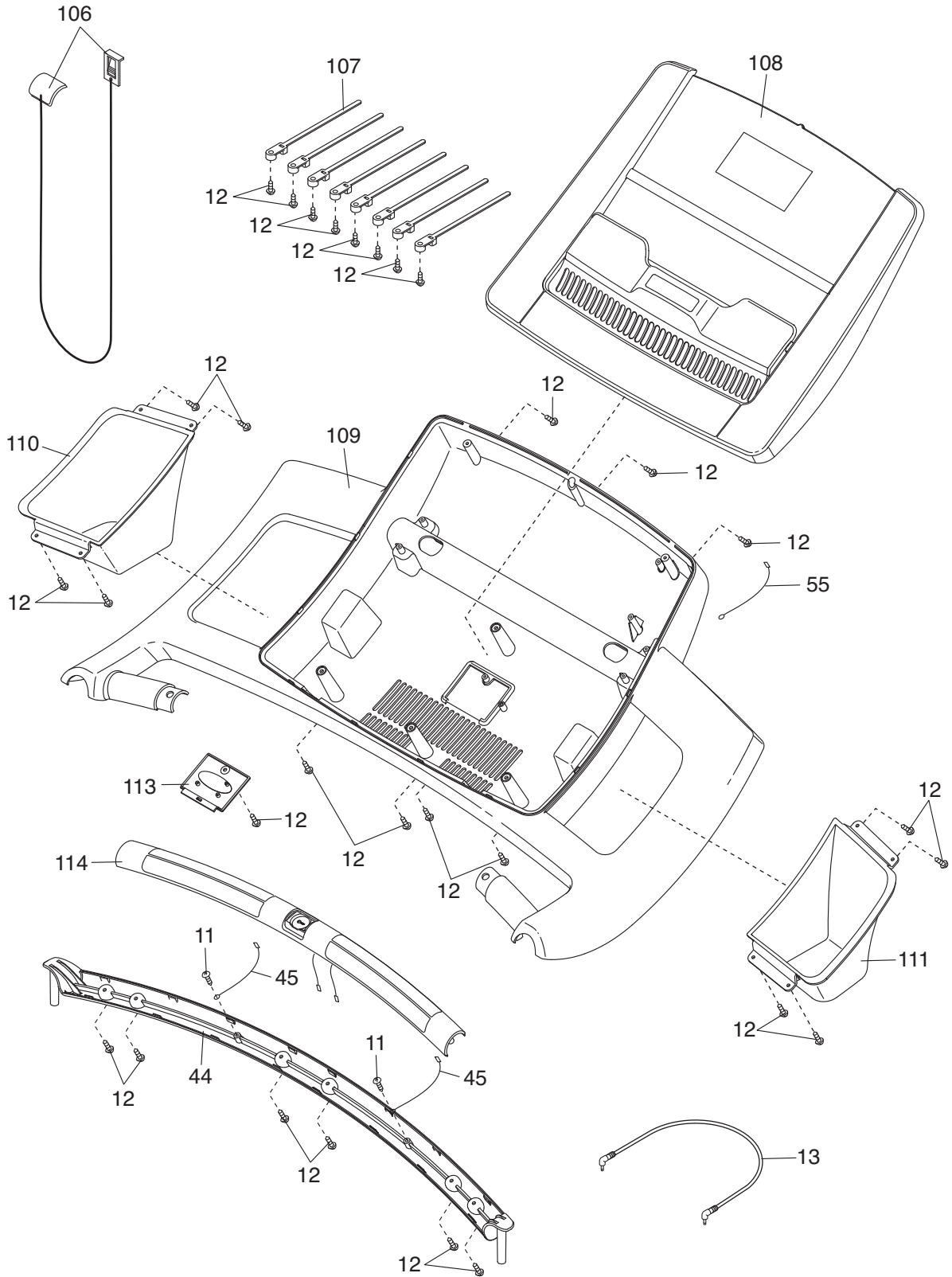

ORDERING REPLACEMENT PARTS

To order replacement parts, please see the front cover of this manual. To help us assist you, be prepared to provide the following information when contacting us:

- the model number and serial number of the product (see the front cover of this manual)
- the name of the product (see the front cover of this manual)
- the key number and description of the replacement part(s) (see the PART LIST and the EXPLODED DRAWING near the end of this manual)

LIMITED WARRANTY

IMPORTANT: You must register this product within 30 days of the purchase date to avoid added fees for service needed under warranty. Go to www.nordictrackservice.com/registration.

ICON Health & Fitness, Inc. (ICON) warrants this product to be free from defects in workmanship and material, under normal use and service conditions. The walking platform, lift frame, and drive motor are warranted for a lifetime. Parts and labor are warranted for one (1) year from the date of purchase.

This warranty extends only to the original purchaser. ICON's obligation under this warranty is limited to repairing or replacing, at ICON's option, the product through one of its authorized service centers. All repairs for which warranty claims are made must be preauthorized by ICON. If the product is shipped to a service center, freight charges to and from the service center will be the customer's responsibility. For replacement parts shipped while the product is under warranty, the customer will be responsible for a minimal handling charge. For in-home service, the customer will be responsible for a minimal trip charge. This warranty does not extend to any damage to a product caused by or attributable to freight damage, abuse, misuse, improper or abnormal usage, or repairs not provided by an ICON authorized service center; to products used for commercial or rental purposes or as store display models; or to products transported or purchased outside the US. No other warranty beyond that specifically set forth above is authorized by ICON.

ICON is not responsible or liable for indirect, special, or consequential damages arising out of or in connection with the use or performance of the product; damages with respect to any economic loss, loss of property, loss of revenues or profits, loss of enjoyment or use, or costs of removal or installation; or other consequential damages of whatsoever nature. Some states do not allow the exclusion or limitation of incidental or consequential damages. Accordingly, the above limitation may not apply to you.

The warranty extended hereunder is in lieu of any and all other warranties, and any implied warranties of merchantability or fitness for a particular purpose are limited in their scope and duration to the terms set forth herein. Some states do not allow limitations on how long an implied warranty lasts. Accordingly, the above limitation may not apply to you.

This warranty gives you specific legal rights. You may also have other rights that vary from state to state.

ICON Health & Fitness, Inc., 1500 S. 1000 W., Logan, UT 84321-9813

Free Manuals Download Website

<http://myh66.com>

<http://usermanuals.us>

<http://www.somanuals.com>

<http://www.4manuals.cc>

<http://www.manual-lib.com>

<http://www.404manual.com>

<http://www.luxmanual.com>

<http://aubethermostatmanual.com>

Golf course search by state

<http://golfingnear.com>

Email search by domain

<http://emailbydomain.com>

Auto manuals search

<http://auto.somanuals.com>

TV manuals search

<http://tv.somanuals.com>