

Hardware Installation Guide



Alteon Web SwitchTM 10/100/1000 Mbps Web Switches

Part Number: 212779, Revision A, December 2001

NORTEL
NETWORKS™

50 Great Oaks Boulevard
San Jose, California 95119

408-360-5500 Main

408-360-5501 Fax

www.nortelnetworks.com

 **Alteon Web Systems**
Intelligent Webworking™

Copyright 2001 Nortel Networks, Inc., 50 Great Oaks Boulevard, San Jose, California 95119, USA. All rights reserved. Part Number: 212779, Revision A.

This document is protected by copyright and distributed under licenses restricting its use, copying, distribution, and decompilation. No part of this document may be reproduced in any form by any means without prior written authorization of Nortel Networks, Inc. Documentation is provided “as is” without warranty of any kind, either express or implied, including any kind of implied or express warranty of non-infringement or the implied warranties of merchantability or fitness for a particular purpose.

U.S. Government End Users: This document is provided with a “commercial item” as defined by FAR 2.101 (Oct 1995) and contains “commercial technical data” and “commercial software documentation” as those terms are used in FAR 12.211-12.212 (Oct 1995). Government End Users are authorized to use this documentation only in accordance with those rights and restrictions set forth herein, consistent with FAR 12.211- 12.212 (Oct 1995), DFARS 227.7202 (JUN 1995) and DFARS 252.227-7015 (Nov 1995).

Nortel Networks, Inc. reserves the right to change any products described herein at any time, and without notice. Nortel Networks, Inc. assumes no responsibility or liability arising from the use of products described herein, except as expressly agreed to in writing by Nortel Networks, Inc. The use and purchase of this product does not convey a license under any patent rights, trademark rights, or any other intellectual property rights of Nortel Networks, Inc.

Alteon 180, Alteon 180-*PLUS*, Alteon 180e, and Alteon 184 are trademarks of Nortel Networks, Inc. in the United States and other countries.

Regulatory Compliance

FCC Class A Notice: This device complies with Part 15 of the FCC Rules. Operation is subject to the following two conditions: 1. This device may not cause harmful interference. 2. This device must accept any interference received, including interference that may cause undesired operation.

Note: This equipment has been tested and found to comply with the limits for a Class A digital device, pursuant to Part 15 of the FCC Rules. These limits are designed to provide reasonable protection against harmful interference when the equipment is operated in a commercial environment. This equipment generates, uses and can radiate radio frequency energy and, if not installed and used in accordance with the instruction manual, may cause harmful interference to radio communications. Operation of this equipment in a residential area is likely to cause harmful interference in which case the user will be required to correct the interference at his own expense.

Do not make mechanical or electrical modifications to the equipment.

VCCI Class A Notice: This is a Class A product based on the standard of the Voluntary Control Council for Interference from Information Technology Equipment (VCCI). If this equipment is used in a domestic environment, radio disturbance may occur, in which case, the user may be required to take corrective actions.

Japanese VCCI Class A Statement:

この装置は、情報処理装置等電波障害自主規制協議会（VCCI）の基準に基づくクラスA情報技術装置です。この装置を家庭環境で使用すると電波妨害を引き起こすことがあります。この場合には使用者が適切な対策を講ずるよう要求されることがあります。

CE Notice: The CE mark on this equipment indicates that this equipment meets or exceeds the following EMC technical standards: EN50024, EN55022, EN50204, EN61000-3-2, EN61000-3-3, EN61000-4-2, EN61000-4-3, EN61000-4-4, and EN61000-4-5, EN61000-4-6, EN61000-4-11.

The equipment also meets or exceeds the following safety technical standards: IEC60950 (CB certified with all member deviations), EN60950, and EN60825-1.

Safety Information

Caution—This Product Contains a Lithium Battery. Batteries are not customer replaceable parts. They may explode if mishandled. Do not dispose of the battery in fire. Do not disassemble or recharge.

Caution—This product is designed to work with single-phase power systems having a grounded neutral conductor. To reduce the risk of electric shock, do not plug this product into any other type of power system. Contact your facilities manager or a qualified electrician if you are not sure what type of power is supplied to your building.

Caution—Not all power cords have the same ratings. Household extension cords do not have overload protection and are not meant for use with computer systems. Do not use household extension cords with this product.

Caution—This product is shipped with a grounding type (three-wire) power cord. To reduce the risk of electric shock, always plug the cord into a grounded power outlet.

Caution—This product uses a 3A/250V fast-acting fuse. For continued protection against the risk of fire, replace only with the same type and rating fuse.

Attention—Utiliser un fusible de rechange de meme type.

Nordic Lithium Battery Cautions

(Norge) ADVARSEL—Litiumbatteri - Eksplosjonsfare. Ved utskifting benyttes kun batteri som anbefalt av apparatfabrikanten. Brukt batteri returneres apparatleverandøren.

(Sverige) VARNING—Explosionsfara vid felaktigt batteribyte. Använd samma batterityp eller en ekvivalent typ som rekommenderas av apparattillverkaren. Kassera använt batteri enligt fabrikantens instruktion.

(Danmark) ADVARSEL! Litiumbatteri - Eksplosionsfare ved fejlagtig håndtering. Udskiftning må kun ske med batteri af samme fabrikat og type. Levér det brugte batteri tilbage til leverandøren.

(Suomi) VAROITUS—Paristo voi räjähtää, jos se on virheellisesti asennettu. Vaihda paristo ainoastaan laitevalmistajan suosittelemaan tyyppiin. Hävitä käytetty paristo valmistajan ohjeiden mukaisesti.

Taiwan EMC Statement

警告使用者：
這是甲類的資訊產品，在居住的環境中使用時，可能會造成射頻干擾，在這種情況下，使用者會被要求採取某些適當的對策。

Contents

Preface 7

- Who Should Use This Book 7
- How This Book Is Organized 7
- Contacting Us 8
- Warranty 8

Chapter 1: The Alteon Web Switch 9

- Physical Description 10
 - Front Panels 10
 - Alteon 180 Series Web Switches 10
 - Alteon AD series Web Switches 11
 - Ports 12
 - Rear Panel 14
 - AC Power 14
 - DC Power 14

Chapter 2: Installing the Switch Hardware 15

- Included Items 15
- Preparing for Installation 15
- Installing the Switch 17
 - Rack-Mounting the Web Switch 17
 - Table-Mounting the Web Switch 18
 - Connecting Power 19
 - AC Power 19
 - DC Power 19
- Connecting Cables to Network Ports 20
 - Gigabit Ethernet via the Fiber Optic SC Connector 21
 - 10/100 Mbps Ethernet via the RJ-45 Connector 21
 - Automatic Selection of Redundant Connections 22

Chapter 3: Using the Console Port 23

Connecting a Serial Cable	23
Establishing a Console Connection	25
Upgrading Software	26
Software Already Installed	26
TFTP Download Through CLI	26
Serial Upgrade	26
Troubleshooting	27
Link LED Does Not Light	27
Symptom	27
Cause	27
Temperature Sensor Error Message	27
Actions	27
Switch Will Not Boot	28
Symptoms	28
Cause	28
Actions	28
Switch Will Not Accept TFTP Software Upgrade	28
Symptoms	28
Cause	28
Actions	28

Appendix A: Specifications 29

Supported Standards	29
Port Specifications	29
Physical Characteristics	30
Power Requirements	30
AC Power	30
DC Power	30
Environmental Specifications	31
Certifications	31

Preface



This manual describes the features and installation process of AD3, AD4, and the Alteon 180 series of Gigabit Ethernet switch hardware.

For full documentation on configuring and using the Web switch's many software features (such as Server Load Balancing and Application Redirection), see the Web OS switch software manuals.

Who Should Use This Book

This manual is intended for network installers and system administrators engaged in configuring and maintaining a Gigabit Ethernet network. It assumes that you are familiar with the Ethernet concepts of the installation—Web switch.

How This Book Is Organized

Chapter 1, “The Alteon Web Switch,” provides a brief overview of the Alteon 180 series (180e, 184) and Alteon AD series (AD3 and AD4) Web switch hardware, including a description of switch features, ports, and LEDs.

Chapter 2, “Installing the Switch Hardware,” describes how to install the Alteon Web switch, and how to connect network cables.

Chapter 3, “Using the Console Port,” describes how to connect a terminal for viewing system messages, and provides suggestions for troubleshooting.

Appendix A, “Specifications,” describes the physical specifications and characteristics of the Alteon Web switches.

Contacting Us

For complete product support and sales information, visit the Nortel Networks website at the following URL:

<http://www.nortelnetworks.com>

See the contact information on this site for regional support and sales phone numbers and e-mail addresses.

- In North America, dial toll-free 1-800-4NORTEL.
- Outside North America, call 987-288-3700.

Warranty

Nortel Networks provides a limited warranty on all its switches for a period of one year from the date of shipment. Free technical support and free replacement of hardware is provided for the first 90 days after shipment. Nortel Networks provides a limited warranty on all its switch software for a period of 90 days from date of shipment. You may choose to purchase additional service and support from Nortel Networks. Please contact your local sales representative for more information.



CHAPTER 1

The Alteon Web Switch

An Alteon Web switch attaches to the network backbone and interconnects servers using 10 Mbps, 100 Mbps, and 1,000 Mbps Ethernet connections. This flexibility off loads server-to-server traffic from the backbone, frees backbone bandwidth, and accelerates client-server performance.

This chapter describes the operational and physical features of the Alteon Web switch hardware.

Physical Description

The following sections describe the Alteon Web switch hardware.

Front Panels

Alteon 180 Series Web Switches

Figure 1 and Figure 2 illustrate the Alteon 180 series switches. Figure 3 and Figure 4 illustrate the Alteon AD3 and Alteon AD4 Web switches. The switch ports are described in “Ports” on page 12.

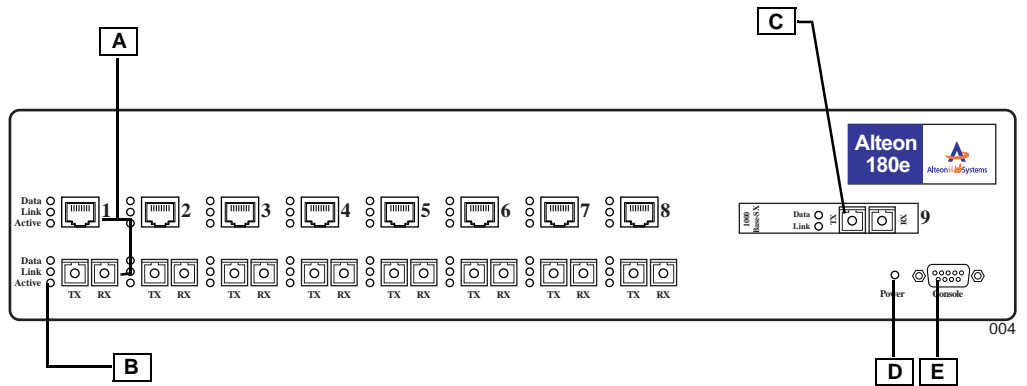

Figure 1 Alteon 180e Front Panel

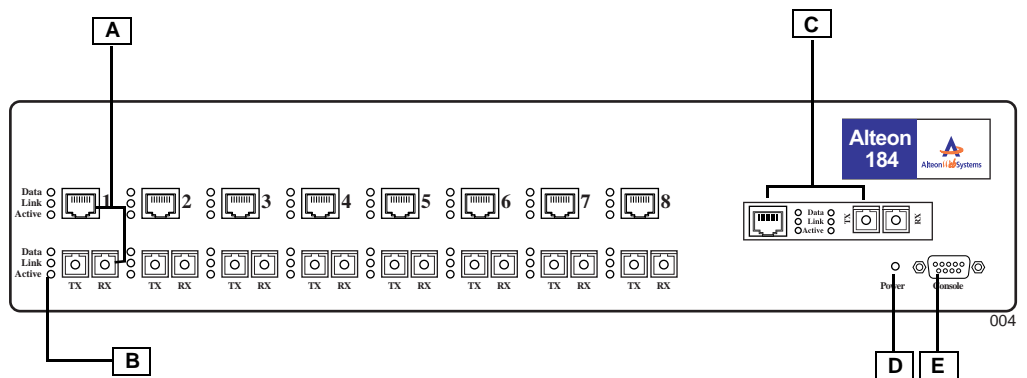

Figure 2 Alteon 184 Front Panel

Alteon AD series Web Switches

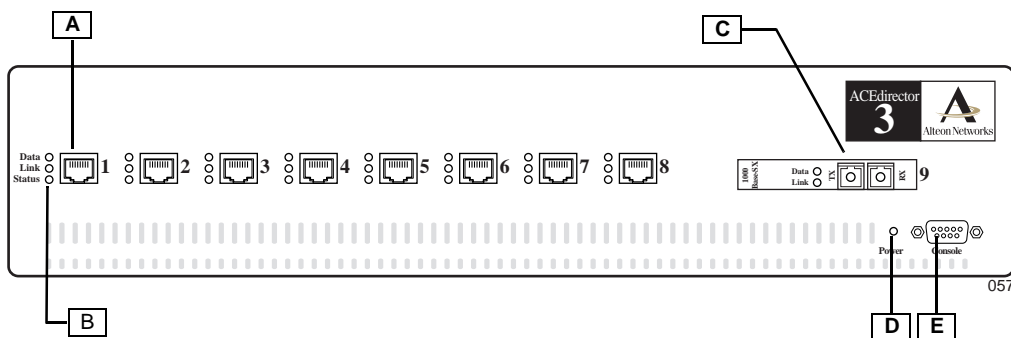

Figure 3 Alteon AD3 Front Panel

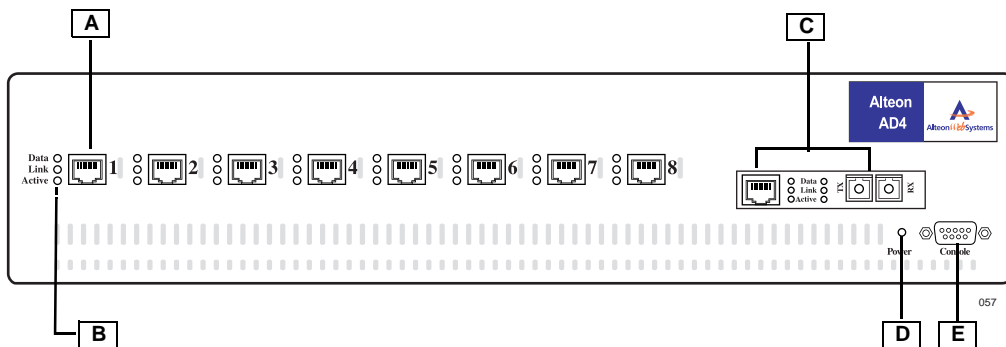

Figure 4 Alteon AD4 Front Panel

Ports

Table 1 shows the port densities for each Alteon Web switch model.

Table 1 Ports of the Alteon 180 and Alteon AD Series

	Alteon 180e	Alteon 184	Alteon AD3	Alteon AD4
Model Number	700107	700116	700106	700117
Port Count				
10/100Base-T Fast Ethernet Ports	8	9	8	9
1000Base-SX Gigabit Ethernet Ports	9	9	1	1

The front panel of the Alteon Web switch has the following features:

- A** Port 1 through Port 8: RJ-45 network ports

NOTE – The Alteon 180 series provides dual-media ports: RJ-45 and SC jacks. The Alteon AD series only provides RJ-45 jacks.

The RJ-45 jack is for connecting 10/100 Mbps Ethernet segments to the port, and the SC jack is for connecting Gigabit Ethernet fiber optic segments. The ports are auto-negotiating and support half- or full-duplex operation. In the Alteon 180 series, only one of the two jacks can be active at any given time. Selection conditions are described in [“Automatic Selection of Redundant Connections”](#) on page 22.

- B** Three LEDs for each network jack

The table below describes the lights and conditions represented by the state of the LEDs.

Table 3 Front Panel Port LEDs

LED	State	Description
Data	Blinking	Data detected on the port.
	Off	No data detected on the port.
Link	On	Good link.
	Off	No link; could be a result of a bad cable or bad connector.
	Blinking	Port has been disabled by software.
Active	On	The jack indicated (either the RJ-45 or the SC) is selected for this port's use.
	Off	The jack is not selected.
All three port LEDs	Flashing in sequence	<i>This pertains only to the Alteon AD series.</i> When no connection is detected on the port, the port LEDs will light in sequence from the bottom LED to the top.

C Port 9: Dedicated uplink port

- The Alteon 180e and Alteon AD3 have one SC-style Gigabit Ethernet fiber optic connector.
- The Alteon 184, 185, and Alteon AD4 have a dual-media network port for either Gigabit Ethernet fiber optic segments, or 10/100 Mbps Fast Ethernet segments.

D A green *Power* LED that lights to indicate that the Alteon Web Switch is on and receiving proper power.

E A female DB-9 serial connector labeled *Console* for the console (DCE) connector

Rear Panel

AC Power

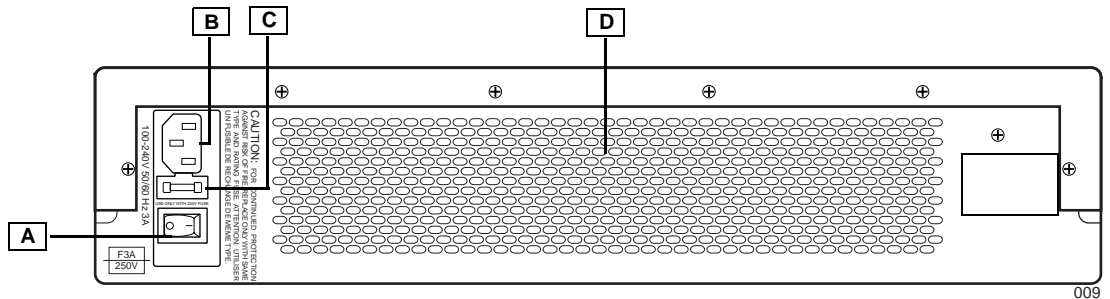

Figure 5 Alton Web Switch Rear Panel—AC Powered Models

The rear panel of the AC-powered Alton series Web switches has the following components:

- A A power switch
- B A fuse housing
- C An AC power connector
- D Air vents and exhaust fans

DC Power

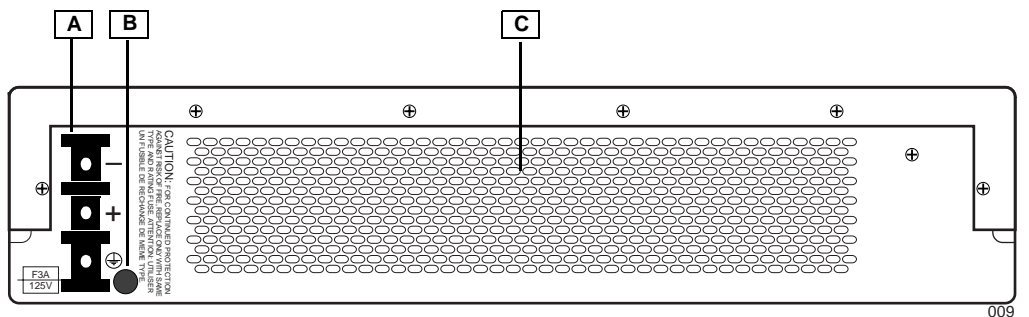

Figure 6 Alton Web Switch Rear Panel—DC Powered Models

The rear panel of the DC-powered Alton Web switches has the following components:

- A A wire terminal block for connecting -48VDC to -60VDC power
- B A fuse housing
- C Air vents and exhaust fan

CHAPTER 2

Installing the Switch Hardware

This chapter describes how to install the Alteon Web switch in a rack or on a table.

Included Items

Your Web switch is shipped with the following items:

- Two mounting brackets (for rack mounting)
- Six Phillips screws for installing the mounting brackets
- Four rubber feet (for tabletop placement of the switch)
- AC power cord (only for AC-powered models)
- A console cable

NOTE – The console cable is not intended for permanent installation and should be disconnected from the console port after configuring the switch.

Preparing for Installation

Switch installation involves the following tasks:

1. **Choosing a suitable location to install the switch.**
2. **Unpacking the switch from the box.**
3. **Turning the power switch to the OFF (O) position.**
4. **Mounting the switch.**
5. **Connecting the power inlet of the Web switch to the appropriate power source.**
6. **Connecting network cables to the switch.**

7. Powering on the switch.

NOTE – The DC powered switch requires insulated copper conductor wire of #12 to #22 AWG. The required wire size is related to the length of the wire. For information, refer to the standard *NEC 1999*.



CAUTION—Observe the following precautions when selecting a site and installing the switch:

Make sure the equipment is properly grounded electrically, and that power connections are safe, particularly when using power strips.

If installing the DC powered switch, the switch chassis must be placed in a location of restricted access—the DC power connectors are open.

Avoid overloading your electrical supply circuits. Electrical ratings are printed on the nameplates of all your equipment. Be sure that your supply circuits and wiring can support the rated power draw of whatever equipment is used.

The ambient temperature of an operating Alteon Web switch must not exceed 40°C. When installing the switch in a closed or multi-unit rack assembly, please consider that the operating ambient temperature of the switch may be higher than the ambient temperature of the room. Take appropriate steps to ensure that the switch does not overheat.

For proper air circulation, the vents on the front, back, and sides of the switch should not be blocked or obstructed by cables, panels, rack frames, or other materials.

Do not place or rack-mount the switch in any way which would exceed the maximum weight bearing capacity of the surface or rack, or which would cause potentially hazardous uneven mechanical loading.

Installing the Switch

Always observe the precautions outlined in the manuals for this and all other equipment you are installing.

Determine whether the unit will be mounted into an equipment rack, or placed free-standing on a shelf or tabletop. The following sections detail each type of installation.

Rack-Mounting the Web Switch

The following instructions are for both the AC and DC powered Alteon switches. There are additional precautions for installing switches equipped with “DC Power” on page 19.

NOTE – Do not use the rubber feet for a rack installation.

1. Connect the two mounting brackets to the switch using the supplied screws as shown in [Figure 7](#).

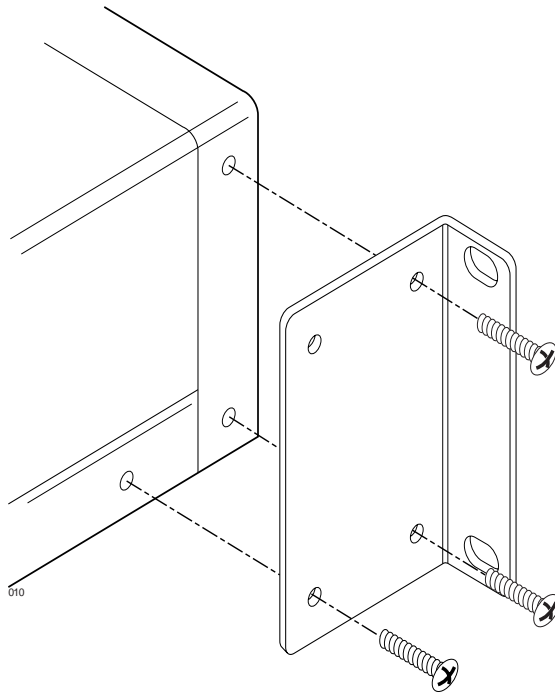

Figure 7 Position Mounting Brackets for Rack Mount

2. Then, install the switch as shown in the figure below using the appropriate screws for your rack-mount system (four 10-32, 12-24, M5X.8-6H, or M6X1-6H type screws).

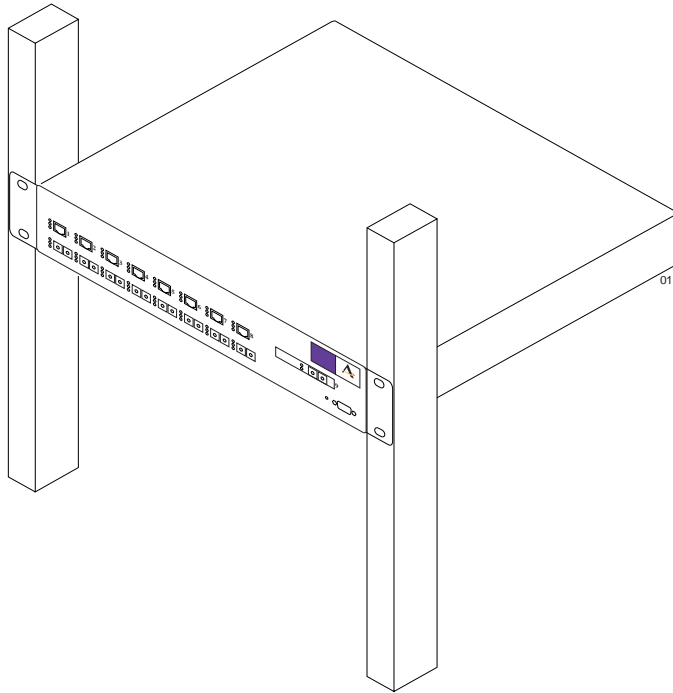

Figure 8 Rack-Mounted Alteon Web Switch

Table-Mounting the Web Switch

1. Attach the four rubber feet to the bottom of the switch.
2. Place the switch onto a level tabletop or equipment shelf.

Connecting Power

The following instructions are for AC powered and DC powered Alteon switches.

AC Power

1. **Connect the power cord to the Web switch. Verify that the power switch is in the off position.**
2. **Plug the switch cord into a properly fused AC outlet.**
3. **Power On (I) the switch.**



CAUTION—The switch uses a 3A/250V fast-acting fuse. For continued protection against risk of fire, replace only with the same type and rating fuse. French: *Attention—Utiliser un fusible de rechange de meme type.*

DC Power

The wire terminal block on the back of the chassis is for connecting the lead wires for standard DC power.

Follow the instructions below to connect the switch to a -48 to -60 VDC SELV source only, in compliance with National Electrical Code (NEC) articles 110-26 and 110-27.

1. **Be sure that DC power is turned off at the source.**
2. **Connect your DC earth-ground lead to the switch  terminal.**

The switch must be connected to a protective earthing terminal in accordance to National Electrical Code (NEC) article 250-160.

Use copper conductor wire of #12 to #22 AWG. Strip 1 cm of the insulation from one end of the ground wire. Loosen the cap of the module's earth-ground terminal (marked ) , and insert the bare end of the wire into the terminal's wire slot.

Make sure that the bare wire makes contact with the metal terminal post. Finally, tighten the terminal cap to secure the wire into place.

3. **Connect the other end of the DC earth-ground lead to the earth-ground terminal on your DC power source.**
4. **Connect each remaining DC power lead to the appropriate wire terminal on the switch.**

Be sure to use copper conductor wire of #12 to #22 AWG when connecting to the terminals.

5. **Connect the other end of each DC power lead to the appropriate wire terminal of your DC power source.**

Connect the DC “+” (common) switch terminal to the source DC “+” common power terminal. Connect the DC “-” (-48) switch terminal to -48 VDC source relative to common.



CAUTION—Be certain that the DC power leads are correctly connected. Improper power connection can damage the switch’s internal fuse.



CAUTION—The fuse can be accessed by unscrewing the fuse cover on the rear panel. Replace only with a fast-acting, **3A, 125VDC**-rated fuse for continued protection against risk of fire. *The fuse must be rated for DC power.*

6. **Install the terminal block safety cover.**
7. **Turn DC power on at the source.**

Connecting Cables to Network Ports

Each network port on Alteon 180 series Web switch has two connector jacks: one RJ-45 jack for connecting 10/100 Mbps Ethernet segments to the port, and one SC jack for connecting 1000 Basic SX Gigabit Ethernet fiber optic segments.

Each network port on Alteon AD series Web switch has only one connector jack: RJ-45, for connecting 10/100 Mbps Ethernet segments to the port.

All ports support full-duplex operation. The 10/100 Mbps ports auto-negotiate, and also support half-duplex operation. On Alteon 180 Web switches, only one of the two jacks can be active at any given time for any port, according to conditions described in [“Automatic Selection of Redundant Connections” on page 22](#).

The port LEDs light to indicate various port connection conditions. See [Table 3 on page 13](#) for details.

Gigabit Ethernet via the Fiber Optic SC Connector

The figure below illustrates an SC-type connector used for Gigabit Ethernet fiber optic connections on the Alteon Web switches:

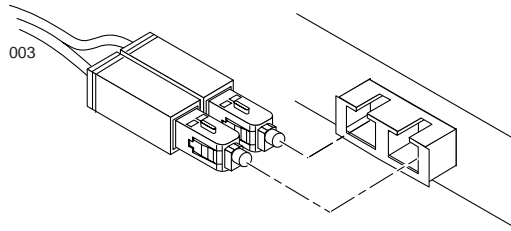

Figure 9 Fiber Optic Connector for Alteon Web Switches

The following table lists the cable characteristics for connecting to 1000Base-SX ports.

Table 4 1000Base-SX Link Characteristics

Description	62.5 Micron Shortwave (850 nm multimode fiber)	50 Micron
Operating Range	2 to 260 meters	2 to 550 meters (in compliance with IEEE 802.3z)

10/100 Mbps Ethernet via the RJ-45 Connector

Use a straight-through cable on the 10/100 Mbps ports if the device attached to the port is a computer. If the device is a switch, hub, or router, use a crossover cable. See the figure below for cabling details. You can use a straight-through cable with a switch, hub, or router if it has an *uplink* enable/disable switch that you can set.

Straight-through cable		Crossover cable	
Switch 10/100 Mbps Port	Computer Port	Switch 10/100 Mbps Port	Hub, Switch, or Router Port
pin 1	————— pin 1	pin 1	————— pin 3
pin 2	————— pin 2	pin 2	————— pin 6
pin 3	————— pin 3	pin 3	————— pin 1
pin 6	————— pin 6	pin 6	————— pin 2

Figure 10 Pin Assignments for 10/100 Mbps Port Cables

Automatic Selection of Redundant Connections

NOTE – This feature is supported only on the Alteon 180 Series Web switches.

The Alteon 180 series' unique dual-media configuration supports automatic bring-up and fail-over between the 10/100 Mbps and 1000 Mbps port-pairs. Order of precedence follows these rules:

- If both the 10/100 Mbps and 1000 Mbps ports are inactive:
 - If the user activates the Gigabit Ethernet port first (by plugging a live cable into the SC-jack), the port immediately becomes active.
 - If the user activates the 10/100 Mbps port first, it remains inactive for a user-selectable timeout (default 1.5 seconds). If the Gigabit Ethernet port is activated prior to the timeout, it becomes the active port. Otherwise, the 10/100 Mbps port becomes active.
- If the active Gigabit Ethernet link fails, the 10/100 Mbps port will become the active port, with minimally required software intervention.
- If the 10/100 Mbps link is active and the Gigabit Ethernet link becomes viable (either because of a newly created connection or because of a repaired link), the 10/100 Mbps link will remain active until one of the following conditions occurs:
 - The 10/100 Mbps link fails or is removed by the user.
 - The user forces the Gigabit Ethernet to become the active link from any management interface.

CHAPTER 3

Using the Console Port

Alteon Web switches have a console port for configuring the switch. This chapter explains how to connect a terminal to the console port.

For instructions on using the console to view and configure switch settings, see the Web OS switch software manuals.

Connecting a Serial Cable

To establish a console (DCE) connection, the following are required:

- An ASCII terminal or a computer running ASCII terminal emulation software set to the parameters shown in the table below:

Table 5 Console Configuration Parameters

Parameter	Value
Baud Rate	9600
Data Bits	8
Parity	None
Stop Bits	1

■ Console Cable

The console port accepts a straight-through serial cable with a male DB9 connector.

Table 6 Pinouts for DB9 Serial Connector

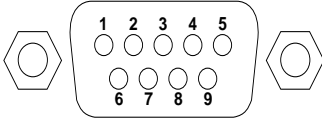
DB9 Serial Connector	Pin	Description
	1	DCD
	2	RxD
	3	TxD
	4	DTR
	5	Ground
	6	DSR
	7	RTS
	8	CTS
	9	Not used

The following figures show the pin assignments for the console to use to configure serial cables to terminal connectors with 9-pin or 25-pin connectors.

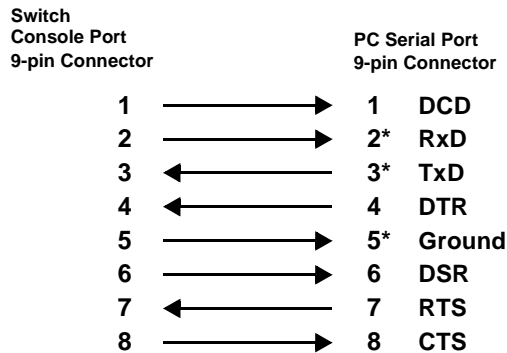

* Only the pins for RxD, TxD, and Ground are required.

Figure 11 9-pin to 9-pin Connector Pin Assignments

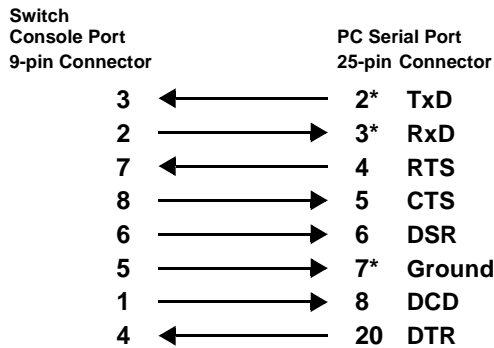

* Only the pins for RxD, TxD, and Ground are required.

Figure 12 9-pin to 25-pin Connector Pin Assignments

NOTE – Console cables are not intended for permanent installation and should be disconnected from the console port after configuring the switch.

Establishing a Console Connection

Following are the instructions to connect a console.

1. **Connect the terminal to the Console port of the switch using the serial cable that is included with your switch.**
2. **Power on the terminal.**
3. **To establish the connection, press <Enter> on your terminal.**
4. **Enter the password when prompted.**

The default administrator password is `admin`. Once your password is verified, the Main menu is displayed. For instructions on using the menus to configure the switch, see the Web OS switch software manuals.

Upgrading Software

Software Already Installed

The Alteon Web switch is provided with the software installed and configured with the factory default settings. For more information, refer to the Web OS software manuals.

TFTP Download Through CLI

Following are outlines of TFTP downloading Web OS software. For details, refer to the Web OS software manuals.

1. **Back up the current Web OS configuration to a file.**
2. **Perform a TFTP download of the Web OS software code onto the selected switch software image.**
3. **Reboot the switch with the selected switch software image.**

Serial Upgrade

NOTE – Serial upgrade is performed through the Console port of the Web switch.

A serial upgrade will erase the current configuration and reconfigure the switch to its factory default settings. It is recommended that you save the current configuration before attempting a serial upgrade.

1. **Back up the current Web OS configuration to a file.**
2. **Perform a serial download of the Web OS image.**
3. **Reboot the Web switch.**

Troubleshooting

This section contains information about possible problems that may occur or error messages that might display if the switch is not properly installed or configured.

Link LED Does Not Light

Symptom

The green *Link* LED does not light. When you check the Link state using the console terminal (see the Web OS switch software manuals), the status is reported as *down*.

Cause

- Port configuration mismatch. If the switch port is configured with a specific speed or duplex mode (for example, 100 Mbps, full duplex) check to see that the other device is set to the same configuration. If the switch port is configured to auto-negotiate, verify that the other device is also set to auto-negotiate. Refer to the appropriate Web OS switch software manuals for more information about setting speed and mode.
- Cable problem. Make sure you are using the correct type of cable to connect the switch to other devices. Refer to [Figure 10 on page 21](#) for information about crossover cables for connecting switches, hubs, or routers to Alteon Web switches.

Temperature Sensor Error Message

The following message is displayed on the console if the temperature of an Alteon Web switch exceeds the threshold. Immediate attention is required.

```
Temperature at sensor xx exceeds threshold  
Current temperature is xx °C   Threshold is xx°C
```

Actions

- Make sure that the air circulation vents on the front, back, and sides of the switch are free from obstruction by cables, panels, rack frames, or other materials.
- Make sure that all four cooling fans inside the switch are running. The fans are located behind the ventilation grill at the rear of the switch. The exhaust from all four fans should be blowing outward with roughly equal air pressure (it is normal for the exhausts to have different temperatures). You can also use a flashlight to check whether the fan blades are moving. If any fan stops during switch operation, contact Customer Support.

- Units in a closed or multi-unit rack assembly may have an operating ambient temperature higher than the ambient temperature of the room. The ambient temperature of an operating switch must not exceed 40°C. If the operating ambient temperature cannot be lowered before this maximum is reached, turn off the switch and let it cool.
- It may be necessary to cool the room to a lower temperature or provide a fan for greater air circulation. Resolve the room's cooling and circulation problems before turning the switch back on.

Switch Will Not Boot

Symptoms

All the Alteon switch LEDs stay on, and the command prompt does not appear on the console.

Cause

The operating system may have been damaged.

Actions

Perform a serial upgrade of the Web switch software. See [“Serial Upgrade” on page 26](#).

Switch Will Not Accept TFTP Software Upgrade

Symptoms

The unit is unable to contact the TFTP server and download files.

Cause

There may be due a problem with the TFTP server, or the Web switch software may be damaged.

Actions

If the software was damaged, perform a serial upgrade of the switch software. See [“Serial Upgrade” on page 26](#).

APPENDIX A

Specifications

Supported Standards

- Spanning Tree Protocol (IEEE 802.1d)
- Logical Link Control (IEEE 802.2)
- 10Base-T/100Base-TX (IEEE 802.3, 802.3u)
- 1000Base-SX (IEEE 802.3z)
- Flow Control (IEEE 802.3x)
- Link Negotiation (IEEE 802.3z)
- Frame Tagging (IEEE 802.1Q) on all ports when VLANs are enabled
- SNMP support: RFC 1213 MIB-II, RFC 1493 Bridge MIB, RFC 1398 Ethernet-like MIB, RFC 1757 RMON1 (groups 1-4), and RFC 1573 Interface Extensions MIB compliant. Alteon Enterprise MIB supporting the configuration and monitoring of all Alteon-specific features.

Port Specifications

Port	Connector	Media	Maximum Distance
10Base-T	RJ-45	UTP Cat. 3, 4, or 5	100 meters (325 feet)
100Base-TX	RJ-45	UTP Cat. 5	100 meters (325 feet)
1000Base-SX	SC full-duplex	Shortwave (850 nm): 62.5 micron MM fiber 50 micron MM fiber	2 to 275 meters (6.5 to 902 feet) 2 to 550 meters (6.5 to 1804 feet)
Console (DCE)	Female DB-9	RS-232C (serial)	25 meters (82 feet)

Physical Characteristics

Characteristic	Measurement
Width	43.18 cm (17.00 inches) (Standard 19" EIA rack mountable)
Height	8.81 cm (3.47 inches)
Depth	45.72 cm (18.00 inches)
Weight	8 kg (18 lb.)

Power Requirements

AC Power

Specification	Measurement
Auto-ranging power supply	100-240VAC @ 50-60 Hz, 3A
Maximum power consumption	90 Watts

DC Power

Specification	Measurement
Auto-ranging power supply	-48 to -60VDC, 3A
Maximum power consumption	80 Watts

Environmental Specifications

Condition	Operating Specification	Storage Specification
Temperature	0° to 40° C (+32° to +104° F)	-40° to +85° C (-40° to +185° F)
Relative humidity	5 to 85% non-condensing (40° C, 16 hour dwells at extremes)	5 to 95% non-condensing 10° C/hour
Altitude	up to 3,050 meters (10,000 feet)	up to 10,750 meters (35,000 feet)
Shock	10g, 1/2 sine wave, 11 msec	60g, 1/2 sine wave, 11 msec
Vibration, peak to peak displacement	0.005 in. max (5 to 32 Hz)	0.1 in. max (5 to 17 Hz)
Vibration, peak acceleration	0.25g (5 to 500 Hz) (Sweep Rate = 1 octave/minute)	0.25g (5 to 500 Hz) (Sweep Rate = 1 octave/minute)

Certifications

Category	Compliance
EMC	CISPR 22/CISPR 24 (International) FCC, CFR 47 Part 15, Class A (USA) CSA CSO3 Class A (Canada) VCCI Class A (Japan) EN 55022/EN 55024 (with required subtest) (Europe) AS/NZ 3548 (Australia/New Zealand) CNS 13438 (Taiwan) MIC (Korea)
Safety	IEC 60950 (International) National Deviation per CB Member Countries to IEC 60950 UL 1950, (USA) CSA 22.2, No. 950 (Canada) EN 60950 (Europe) NOM-D19-SCFI - 1998 (Mexico) IEC 60950 with deviations (Argentina) IEC 60950 with deviations (Chile)

Free Manuals Download Website

<http://myh66.com>

<http://usermanuals.us>

<http://www.somanuals.com>

<http://www.4manuals.cc>

<http://www.manual-lib.com>

<http://www.404manual.com>

<http://www.luxmanual.com>

<http://aubethermostatmanual.com>

Golf course search by state

<http://golfingnear.com>

Email search by domain

<http://emailbydomain.com>

Auto manuals search

<http://auto.somanuals.com>

TV manuals search

<http://tv.somanuals.com>