



Nortel Metro Ethernet Routing Switch 8600

## Installation — Modules

---

NN46220-306

Document status: Standard  
Document version: 02.02  
Document date: 7 July 2008

Copyright © 2005-2007, Nortel Networks  
All Rights Reserved.

Sourced in Canada and the United States of America

This document is protected by copyright laws and international treaties. All information, copyrights and any other intellectual property rights contained in this document are the property of Nortel Networks. Except as expressly authorized in writing by Nortel Networks, the holder is granted no rights to use the information contained herein and this document shall not be published, copied, produced or reproduced, modified, translated, compiled, distributed, displayed or transmitted, in whole or part, in any form or media.

The information in this document is subject to change without notice. The statements, configurations, technical data, and recommendations in this document are believed to be accurate and reliable, but are presented without express or implied warranty. Users must take full responsibility for their applications of any products specified in this document. The information in this document is proprietary to Nortel Networks Inc.

## **Statement of conditions**

In the interest of improving internal design, operational function, and/or reliability, Nortel Networks Inc. reserves the right to make changes to the products described in this document without notice.

Nortel Networks Inc. does not assume any liability that may occur due to the use or application of the product(s) or circuit layout(s) described herein.

## **International regulatory statements of conformity**

This is to certify that the Nortel Networks 8000 Series chassis and components installed within the chassis were evaluated to the international regulatory standards for electromagnetic compliance (EMC) and safety and were found to have met the requirements for the following international standards:

- EMC - Electromagnetic Emissions – CISPR 22, Class A
- EMC - Electromagnetic Immunity – CISPR 24
- Electrical Safety – IEC 60950, with CB member national deviations

Further, the equipment has been certified as compliant with the national standards as detailed below.

## **National electromagnetic compliance (EMC) statements of compliance FCC statement (USA only)**

This equipment has been tested and found to comply with the limits for a Class A digital device, pursuant to Part 15 of the Federal Communications Commission (FCC) rules. These limits are designed to provide reasonable protection against harmful interference when the equipment is operated in a commercial environment. This equipment generates, uses, and can radiate radio frequency energy. If it is not installed and used in accordance with the instruction manual, it may cause harmful interference to radio communications. Operation of this equipment in a residential area is likely to cause harmful interference, in which case users will be required to take whatever measures may be necessary to correct the interference at their own expense.

## **ICES statement (Canada only)**

### **Canadian Department of Communications Radio Interference Regulations**

This digital apparatus (8000 Series chassis and installed components) does not exceed the Class A limits for radio-noise emissions from digital apparatus as set out in the Radio Interference Regulations of the Canadian Department of Communications.

## Règlement sur le brouillage radioélectrique du ministère des Communications

Cet appareil numérique (8000 Series chassis) respecte les limites de bruits radioélectriques visant les appareils numériques de classe A prescrites dans le Règlement sur le brouillage radioélectrique du ministère des Communications du Canada.

### CE marking statement (Europe only) EN 55 022 statements

This is to certify that the Nortel Networks 8000 Series chassis and components installed within the chassis are shielded against the generation of radio interference in accordance with the application of Council Directive 89/336/EEC. Conformity is declared by the application of EN 55 022 Class A (CISPR 22).



#### WARNING

This is a Class A product. In a domestic environment, this product may cause radio interference, in which case, the user may be required to take appropriate measures.

#### ATTENTION

##### Achtung:

Dieses ist ein Gerät der Funkstörgrenzwertklasse A. In Wohnbereichen können bei Betrieb dieses Gerätes Rundfunkstörungen auftreten, in welchen Fällen der Benutzer für entsprechende Gegenmaßnahmen verantwortlich ist.

#### ATTENTION

Ceci est un produit de Classe A. Dans un environnement domestique, ce produit risque de créer des interférences radioélectriques, il appartiendra alors à l'utilisateur de prendre les mesures spécifiques appropriées.

### EN 55 024 statement

This is to certify that the Nortel Networks 8000 Series chassis is shielded against the susceptibility to radio interference in accordance with the application of Council Directive 89/336/EEC. Conformity is declared by the application of EN 55 024 (CISPR 24).

### EC Declaration of Conformity

This product conforms to the provisions of the R&TTE Directive 1999/5/EC.

### VCCI statement (Japan/Nippon only)

This is a Class A product based on the standard of the Voluntary Control Council for Interference (VCCI) for information technology equipment. If this equipment is used in a domestic environment, radio disturbance may arise. When such trouble occurs, the user may be required to take corrective actions.

この装置は、情報処理装置等電波障害自主規制協議会（VCCI）の基準に基づくクラスA情報技術装置です。この装置を家庭環境で使用すると電波妨害を引き起こすことがあります。この場合には使用者が適切な対策を講ずるよう要求されることがあります。

## BSMI statement for 8010, 8006 and 8003 chassis (Taiwan only)

This is a Class A product based on the standard of the Bureau of Standards, Metrology and Inspection (BSMI) CNS 13438, Class A.

警告使用者：

這是甲類的資訊產品，在居住的環境中使用時，可能會造成射頻干擾，在這種情況下，使用者會被要求採取某些適當的對策。

## MIC notice for 8010, 8006, 8003 chassis (Republic of Korea only)

This device has been approved for use in Business applications only per the Class A requirements of the Republic of Korea Ministry of Information and Communications (MIC). This device may not be sold for use in a non-business application.



## National safety statements of compliance

### CE marking statement (Europe only)

#### EN 60 950 statement

This is to certify that the Nortel Networks 8000 Series chassis and components installed within the chassis are in compliance with the requirements of EN 60 950 in accordance with the Low Voltage Directive. Additional national differences for all European Union countries have been evaluated for compliance. Some components installed within the 8000 Series chassis may use a nickel-metal hydride (NiMH) and/or lithium-ion battery. The NiMH and lithium-ion batteries are long-life batteries, and it is very possible that you will never need to replace them. However, should you need to replace them, refer to the individual component manual for directions on replacement and disposal of the battery.

## NOM statement 8010, 8006, and 8003 chassis (Mexico only)

The following information is provided on the devices described in this document in compliance with the safety requirements of the Norma Oficial Mexicana (NOM):

Exporter: Nortel Networks, Inc.  
4655 Great America Parkway  
Santa Clara CA 95054 USA

Importer: Nortel Networks de México, S.A. de C.V.  
Avenida Insurgentes Sur #1605  
Piso 30, Oficina  
Col. San Jose Insurgentes  
Deleg-Benito Juarez  
México D.F. 03900

Tel: 52 5 480 2100

Fax: 52 5 480 2199

Input: Model 8003AC:  
100-240 VAC, 50-60 Hz, 9 A max. per power supply

Model 8004AC:  
100-240 VAC, 50 to 60 Hz, 12-6 A max. per power supply  
single supply, single supply + one redundant supply, two supplies, or two + one redundant supply configuration

Model 8005AC:  
100 to 120 VAC, 50 to 60 Hz, 16 A max. per power supply  
200 to 240 VAC, 50 to 60 Hz, 9.5 A max. per power supply  
single supply, single supply + one redundant supply, two supplies, or two + one redundant supply configuration

Model 8004DC:  
-48 VDC, 29 A  
single supply, single supply + one redundant supply, two supplies, or two + one redundant supply configuration

Model 8005DC:  
-48 VDC, 42 A  
single supply, single supply + one redundant supply, two supplies, or two + one redundant supply configuration

## Información NOM (unicamente para México)

La información siguiente se proporciona en el dispositivo o en los dispositivos descritos en este documento, en cumplimiento con los requisitos de la Norma Oficial Mexicana (NOM):

Exportador: Nortel Networks, Inc.  
4655 Great America Parkway  
Santa Clara, CA 95054 USA

Importador: Nortel Networks de México, S.A. de C.V.  
Avenida Insurgentes Sur #1605  
Piso 30, Oficina  
Col. San Jose Insurgentes  
Deleg-Benito Juarez  
México D.F. 03900

Tel: 52 5 480 2100

Fax: 52 5 480 2199

Embarcar a: Model 8003AC:  
100-240 VCA, 50-60 Hz, 9 A max. por fuente de poder

Model 8004AC:  
100-240 VCA, 50 - 60 Hz, 12-6 A max. por fuente de poder  
una fuente, una fuente + configuraciones de una fuente redundante,  
dos fuentes o dos + configuraciones de una fuente redundante

Model 8005AC:  
100 - 120 VCA, 50 -60 Hz, 16 A max. por fuente de poder  
200 - 240 VCA, 50 - 60 Hz, 9.5 A max. por fuente de poder

una fuente, una fuente + configuraciones de una fuente redundante,  
dos fuentes o dos + configuraciones de una fuente redundante

Model 8004DC:

-48 VCD, 29 A

una fuente, una fuente + configuraciones de una fuente redundante,  
dos fuentes o dos + configuraciones de una fuente redundante

Model 8005DC:

-48 VCD, 42 A

una fuente, una fuente + configuraciones de una fuente redundante,  
dos fuentes o dos + configuraciones de una fuente redundante

## Nortel Networks Inc. software license agreement

This Software License Agreement ("License Agreement") is between you, the end-user ("Customer") and Nortel Networks Corporation and its subsidiaries and affiliates ("Nortel Networks"). PLEASE READ THE FOLLOWING CAREFULLY. YOU MUST ACCEPT THESE LICENSE TERMS IN ORDER TO DOWNLOAD AND/OR USE THE SOFTWARE. USE OF THE SOFTWARE CONSTITUTES YOUR ACCEPTANCE OF THIS LICENSE AGREEMENT. If you do not accept these terms and conditions, return the Software, unused and in the original shipping container, within 30 days of purchase to obtain a credit for the full purchase price.

"Software" is owned or licensed by Nortel Networks, its parent or one of its subsidiaries or affiliates, and is copyrighted and licensed, not sold. Software consists of machine-readable instructions, its components, data, audio-visual content (such as images, text, recordings or pictures) and related licensed materials including all whole or partial copies. Nortel Networks grants you a license to use the Software only in the country where you acquired the Software. You obtain no rights other than those granted to you under this License Agreement. You are responsible for the selection of the Software and for the installation of, use of, and results obtained from the Software.

- 1. Licensed Use of Software.** Nortel Networks grants Customer a nonexclusive license to use a copy of the Software on only one machine at any one time or to the extent of the activation or authorized usage level, whichever is applicable. To the extent Software is furnished for use with designated hardware or Customer furnished equipment ("CFE"), Customer is granted a nonexclusive license to use Software only on such hardware or CFE, as applicable. Software contains trade secrets and Customer agrees to treat Software as confidential information using the same care and discretion Customer uses with its own similar information that it does not wish to disclose, publish or disseminate. Customer will ensure that anyone who uses the Software does so only in compliance with the terms of this Agreement. Customer shall not a) use, copy, modify, transfer or distribute the Software except as expressly authorized; b) reverse assemble, reverse compile, reverse engineer or otherwise translate the Software; c) create derivative works or modifications unless expressly authorized; or d) sublicense, rent or lease the Software. Licensees of intellectual property to Nortel Networks are beneficiaries of this provision. Upon termination or breach of the license by Customer or in the event designated hardware or CFE is no longer in use, Customer will promptly return the Software to Nortel Networks or certify its destruction. Nortel Networks may audit by remote polling or other reasonable means to determine Customer's Software activation or usage levels. If suppliers of third party software included in Software require Nortel Networks to include additional or different terms, Customer agrees to abide by such terms provided by Nortel Networks with respect to such third party software.
- 2. Warranty.** Except as may be otherwise expressly agreed to in writing between Nortel Networks and Customer, Software is provided "AS IS" without any warranties (conditions) of any kind. NORTEL NETWORKS DISCLAIMS ALL WARRANTIES (CONDITIONS) FOR THE SOFTWARE, EITHER EXPRESS OR IMPLIED, INCLUDING, BUT NOT LIMITED TO THE IMPLIED WARRANTIES OF MERCHANTABILITY AND FITNESS FOR A PARTICULAR PURPOSE AND ANY WARRANTY OF NON-INFRINGEMENT. Nortel Networks is not obligated to provide support of any kind for the Software. Some jurisdictions do not allow exclusion of implied warranties, and, in such event, the above exclusions may not apply.
- 3. Limitation of Remedies.** IN NO EVENT SHALL NORTEL NETWORKS OR ITS AGENTS OR SUPPLIERS BE LIABLE FOR ANY OF THE FOLLOWING: a) DAMAGES BASED ON ANY THIRD PARTY CLAIM; b) LOSS OF, OR DAMAGE TO, CUSTOMER'S RECORDS, FILES OR DATA; OR c) DIRECT, INDIRECT, SPECIAL, INCIDENTAL, PUNITIVE, OR CONSEQUENTIAL DAMAGES (INCLUDING LOST PROFITS OR SAVINGS), WHETHER IN CONTRACT, TORT OR OTHERWISE (INCLUDING NEGLIGENCE) ARISING OUT OF YOUR USE OF THE SOFTWARE, EVEN IF NORTEL NETWORKS, ITS AGENTS OR SUPPLIERS HAVE BEEN ADVISED OF THEIR POSSIBILITY. The forgoing limitations of remedies also apply to any developer and/or

supplier of the Software. Such developer and/or supplier is an intended beneficiary of this Section. Some jurisdictions do not allow these limitations or exclusions and, in such event, they may not apply.

#### 4. **General**

- a. If Customer is the United States Government, the following paragraph shall apply: All Nortel Networks Software available under this License Agreement is commercial computer software and commercial computer software documentation and, in the event Software is licensed for or on behalf of the United States Government, the respective rights to the software and software documentation are governed by Nortel Networks standard commercial license in accordance with U.S. Federal Regulations at 48 C.F.R. Sections 12.212 (for non-DoD entities) and 48 C.F.R. 227.7202 (for DoD entities).
- b. Customer may terminate the license at any time. Nortel Networks may terminate the license if Customer fails to comply with the terms and conditions of this license. In either event, upon termination, Customer must either return the Software to Nortel Networks or certify its destruction.
- c. Customer is responsible for payment of any taxes, including personal property taxes, resulting from Customer's use of the Software. Customer agrees to comply with all applicable laws including all applicable export and import laws and regulations.
- d. Neither party may bring an action, regardless of form, more than two years after the cause of the action arose.
- e. The terms and conditions of this License Agreement form the complete and exclusive agreement between Customer and Nortel Networks.
- f. This License Agreement is governed by the laws of the country in which Customer acquires the Software. If the Software is acquired in the United States, then this License Agreement is governed by the laws of the state of New York.





---

# Contents

---

<b>New in this release</b>	<b>13</b>
Features	13
Other changes	13
Document changes	13
<b>Introduction</b>	<b>15</b>
<b>Metro Ethernet Routing Switch 8600 modules</b>	<b>17</b>
Metro Ethernet Routing Switch 8600 modules interface characteristics	18
Metro Ethernet Routing Switch 8600 pre-E, E, and M modules feature set	21
Metro Ethernet Routing Switch 8600 R module feature set	21
M mode configuration requirements	23
R mode configuration requirements	24
ESM 8668 Metro Ethernet Services Module	25
8608GBE and 8608GBM modules	25
8608GTE and 8608GTM modules	27
8608SXE module	30
8616GTE module	32
8616SXE module	33
8624FXE module	35
8630GBR module	37
8632TXE and 8632TXM modules	41
8648GTR module	44
8648TXE and 8648TXM modules	46
ESM 8668 Metro Ethernet Services Module	49
8672ATME and 8672ATMM modules	50
8681XLR module	52
8681XLW module	54
8683POSM module	56
8683XLR module	58
8683XZR module	61
8691omSF module	63
Ethernet management port	66
DCE/DTE switch	67
Serial ports	67

- Reset button 67
- PC Card slot 67
- 8692omSF module 67
  - LEDs 69
  - Ethernet management port 71
  - DCE/DTE switch 71
  - Serial ports 71
- Reset button 72
- PC Card slot 72

---

**Installing Metro Ethernet Routing Switch 8600 modules and connecting equipment 73**

- Removing a filler panel 73
- Installing a filler panel 75
- Installing and replacing a module 75
  - Removing a module 76
  - Installing a module 81
- Connecting a PC or terminal to the switch 86
- Connecting a modem to the switch 86
- Connecting a network management station to the switch 88
- Connecting communications cables to Metro Ethernet Routing Switch 8600 modules 89
- Managing cables for the Ethernet Routing Switch 8000 Series chassis 93
- Initializing the 8672ATME, 8672ATMM, and 8683POSM modules 96
  - Initializing the 8672ATME and 8672ATMM modules 97
  - Initializing the 8683POSM module 99

---

**Appendix A Metro Ethernet Routing Switch 8600 module technical specifications 101**

- General specifications 102
- 8608GBE and 8608GBM modules 105
  - GBICs 105
- 8608GTE and 8608GTM modules 107
  - Port connectors 108
- 8608SXE module 109
- 8616GTE module 110
  - Port connectors 111
- 8616SXE module 111
- 8624FXE module 113
- 8630GBR module 114
  - Gigabit Ethernet SFP transceivers 114
- 8632TXE and 8632TXM modules 115
  - GBICs 116
- 8648GTR module 116
  - Port connectors 117

---

---

8648TXE and 8648TXM modules	117
Port connectors	118
ESM 8668 Metro Ethernet Services Module	119
8672ATME and 8672ATMM modules	119
8681XLR module	121
8681XLW module	123
8683POSM module	124
8683XLR module	126
XFPs	127
8683XZR module	127
XFPs	128
8691omSF module	128
Management port	129
Console serial port	130
Modem serial port	130
8692omSF module	131
Management port	132
Console serial port	132
Modem serial port	133

---

## **Appendix B Installing the Metro Ethernet enhanced CPU daughter card**

135

Installing the jumper on an ESM 8668 139



---

## New in this release

---

The following describes what's new in *Nortel Metro Ethernet Routing Switch 8600 Installation — Modules* (NN46220-306).

### Features

The following features are new in *Nortel Metro Ethernet Routing Switch 8600 Installation — Modules* (NN46220-306) for this release:

- Metro Ethernet Routing Switch 8600 support for the SFP AA1419071 and XFP AA1403006 on the 8630GBR module (see "[8630GBR module](#)" ([page 37](#)))
- Metro Ethernet Routing Switch 8600 support for the SFP AA1419071 on the ESM 8668 module (see "[ESM 8668 Metro Ethernet Services Module](#)" ([page 49](#)))
- A command was added to the procedure for installing a module when the slot is disabled. For more information, see "[Installing a module](#)" ([page 81](#)).

### Other changes

This section describes the changes that are not feature-related.

#### Document changes

- This book is reformatted to comply with the Nortel Customer Documentation Standard (NCDS) guidelines.



---

# Introduction

---

The Nortel Ethernet Routing Switch 8000 Series chassis provides the physical enclosure for the Metro Ethernet Routing Switch 8600 modules. When Metro Ethernet Routing Switch 8600 modules are installed in the chassis, the resulting Metro Ethernet Routing Switch 8600 provides a range of data speeds and high-performance switching and routing features.

This guide provides instructions for installing the Metro Ethernet Routing Switch 8600 modules in a Ethernet Routing Switch 8000 Series chassis.

This guide is intended for qualified service personnel who need to install or replace a Metro Ethernet Routing Switch 8600 module in the chassis.

## Prerequisites

- A qualified service person should have appropriate technical training and experience and be aware of the hazards involved in installing and replacing customer-replaceable units.

## Navigation

- ["Metro Ethernet Routing Switch 8600 modules" \(page 17\)](#)
- ["Installing Metro Ethernet Routing Switch 8600 modules and connecting equipment" \(page 73\)](#)
- [Appendix "Metro Ethernet Routing Switch 8600 module technical specifications" \(page 101\)](#)
- [Appendix "Installing the Metro Ethernet enhanced CPU daughter card" \(page 135\)](#)





---

# Metro Ethernet Routing Switch 8600 modules

---

The Metro Ethernet Routing Switch 8600 modules provide a full complement of core routing and switching capabilities in an Ethernet Routing Switch 8000 Series chassis. The Metro Ethernet Routing Switch 8600 modules include switch fabric (SF) modules and interface modules. An Ethernet Routing Switch 8000 Series chassis with installed Metro Ethernet Routing Switch 8600 modules constitutes a Metro Ethernet Routing Switch 8600 with distributed management and full redundancy that delivers wire-speed routing and Layer 2 switching.

## Navigation

- ["Metro Ethernet Routing Switch 8600 modules interface characteristics" \(page 18\)](#)
- ["Metro Ethernet Routing Switch 8600 pre-E, E, and M modules feature set" \(page 21\)](#)
- ["Metro Ethernet Routing Switch 8600 R module feature set" \(page 21\)](#)
- ["M mode configuration requirements" \(page 23\)](#)
- ["R mode configuration requirements" \(page 24\)](#)
- ["ESM 8668 Metro Ethernet Services Module" \(page 25\)](#)
- ["8608GBE and 8608GBM modules" \(page 25\)](#)
- ["8608GTE and 8608GTM modules" \(page 27\)](#)
- ["8608SXE module" \(page 30\)](#)
- ["8616GTE module" \(page 32\)](#)
- ["8616SXE module" \(page 33\)](#)
- ["8624FXE module" \(page 35\)](#)
- ["8630GBR module" \(page 37\)](#)
- ["8632TXE and 8632TXM modules" \(page 41\)](#)
- ["8648GTR module" \(page 44\)](#)

- "8648TXE and 8648TXM modules" (page 46)
- "ESM 8668 Metro Ethernet Services Module" (page 49)
- "8672ATME and 8672ATMM modules" (page 50)
- "8681XLR module" (page 52)
- "8681XLW module" (page 54)
- "8683POSM module" (page 56)
- "8683XLR module" (page 58)
- "8683XZR module" (page 61)
- "8691omSF module" (page 63)
- "8692omSF module" (page 67)

## **Metro Ethernet Routing Switch 8600 modules interface characteristics**

The Metro Ethernet Routing Switch 8600 modules support different types of interfaces with different speeds and port types, including:

- 10/100 megabit per second (Mb/s) autonegotiating twisted pair Ethernet ports
- 100 Mb/s fiber Ethernet ports
- 1 gigabit per second (Gb/s) (1000 Mb/s) fiber and copper Ethernet ports
- 10 Gb/s (10 000 Mb/s) fiber Ethernet ports
- asynchronous transfer mode (ATM) OC-3c/STM-1, OC-12c and DS-3 ports
- POS OC-3c/STM-1 and OC-12c/STM-4 ports
- SFP Ethernet ports

Each Metro Ethernet Routing Switch 8600 interface module supports varying numbers and types of interfaces. The different interface types and the maximum port densities available with each type are listed in "[Maximum port densities for Metro Ethernet Routing Switch 8600 modules](#)" (page 19).

**Maximum port densities for Metro Ethernet Routing Switch 8600 modules**

Module type	Port type	Maximum number of ports per chassis		
		8003	8006	8010 and 8010co
8608GBE and 8608GBM	1000BaseSX	16	32	64
	1000BaseLX	16	32	64
	1000BaseZX	16	32	64
	1000BaseXD	16	32	64
	1000BaseCWDM	16	32	64
	1000BaseT	16	32	64
8608GTE and 8608GTM	1000BaseT	16	32	64
8608SXE	1000BaseSX	16	32	64
8616GTE	1000BaseT	32	64	128
8616SXE	1000BaseSX	32	64	128
8624FXE	100BaseFX	48	96	192
8630GBR	1000BaseSX	Not supported	120	240
	1000BaseLX	Not supported	120	240
	1000BaseZX	Not supported	120	240
	1000BaseXD	Not supported	120	240
	1000BaseCWDM	Not supported	120	240
	1000BaseT	Not supported	120	240
8632TXE and 8632TXM	10BaseT/100BaseTX	64	128	256
	1000BaseSX	4	8	16
	1000BaseLX	4	8	16
	1000BaseZX	4	8	16
	1000BaseXD	4	8	16
	1000BaseCWDM	4	8	16
	1000BaseT	4	8	16
8648GTR	10BaseT/100BaseTX/ 1000BaseT	Not supported	192	384

Module type	Port type	Maximum number of ports per chassis		
		8003	8006	8010 and 8010co
8648TXE and 8648TXM	10BaseT/100BaseTX	96	192	384
Metro ESM 8668 (see Note 1)	1000BaseSX (SFP)	NA	24	56
	1000BaseLX (SFP)	NA	24	56
	1000BaseCWDM (SFP)	NA	24	56
	1000BaseT (SFP)	NA	24	56
	1000BaseBX (SFP)	NA	24	56
8672ATME and 8672ATMM (see Note 2)	OC-3c MDA	16	32	48
	OC-12c MDA	4	8	12
	DS-3 MDA	8	16	24
8681XLR (see Note 3)	10-GBaseLR	2	4	8
8681XLW (see Note 3)	10-GBaseLW	2	4	8
8683XLR	10GBaseSR	Not supported	12	24
	10GBaseLR	Not supported	12	24
	10GBaseER	Not supported	12	24
	10GBaseZR	Not supported	4	8
8683XZR	10GBaseSR	Not supported	12	24
	10GBaseLR/LW	Not supported	12	24
	10GBaseER/EW	Not supported	12	24
	10GBaseZR/ZW	Not supported	4	8

Module type	Port type	Maximum number of ports per chassis		
		8003	8006	8010 and 8010co
8683POSM (see Note 4)	OC-3c MDA	12	24	24
	OC-12c MDA	6	12	12

Note 1: The 8003 chassis is not supported with Metro Ethernet Routing Switch 8600.

Note 2: For information about these Media Dependent Adapters (MDA), see "[8672ATME and 8672ATMM modules](#)" (page 50). The 8672ATME and 8672ATMM modules are not supported with Metro Ethernet Routing Switch 8600 Ethernet VPN services.

Note 3: Metro Ethernet Routing Switch 8600 does not support the 8681XLR and 8681XLW modules.

Note 4: For information about these MDAs, see "[8683POSM module](#)" (page 56). The 8683POSM module is not supported with Metro Ethernet Routing Switch 8600 Ethernet VPN services.

## Metro Ethernet Routing Switch 8600 pre-E, E, and M modules feature set

Each Metro Ethernet Routing Switch 8600 pre-E, E, or M module consists of a Backplane Forwarding Module (BFM) with common application specific integrated circuits (ASIC) on each module. These ASICs provide a forwarding engine and local storage of Layer 2 to 4 forwarding tables. Each forwarding engine provides lookups, resolves addresses and sends packets through the switch fabric to a destination port without CPU intervention. The forwarding engine also filters packets against current prioritization policies and can set prioritization information in the internal packet header.

The BFM is also equipped with eight priority queues per port. You can use either of the following two prioritization schemes:

- Strict priority
- Weighted Round Robin (WRR)

Strict priority guarantees the highest priority. WRR gives priority based on a round robin algorithm. For more information about prioritization schemes see *Network Design Guidelines* (313197-E).

Output buffer memory consists of 8 MB of memory allocated to each Gigabit Ethernet port or shared among eight 10/100 ports.

Note that Metro Ethernet Routing Switch 8600 does not support pre-E modules.

## Metro Ethernet Routing Switch 8600 R module feature set

Each Metro Ethernet Routing Switch 8600 R module (Release 4.0 and later) consists of a Distributed Processing Module (DPM) as well as a Port Interface Module (PIM). The PIM consists of various Media Access Controls

(MAC) and Physical Layer Controls (PHY) as well as the physical interfaces for direct network connections. A single PIM interconnects with a single DPM to form a Metro Ethernet Routing Switch 8600 Module. Modules with DPMs are R modules.

Metro Ethernet Routing Switch 8600 modules that use the BFM are pre-E, E, or M modules. These modules are described in "[Metro Ethernet Routing Switch 8600 pre-E, E, and M modules feature set](#)" (page 21).

Each DPM contains either two or three lanes, depending on the module. Both the 8630GBR and the 8683XLR modules consist of three lanes. The 8648GTR module consists of two lanes. Each lane is also known as a Flexible Forwarding Engine (FFE). The FFE lane is the basis for the Metro Ethernet Routing Switch 8600 R modules. The FFE lane consists of:

- Two Flexible Route Switch Processors—ingress Route Switch Processor 2 (RSP2) and egress RSP2
- One egress packet handling ASIC—F2E
- One ingress packet handling ASIC—F2I

"[Metro Ethernet Routing Switch 8600 R module packet flow on ingress and egress](#)" (page 22) shows the Metro Ethernet Routing Switch 8600 R module packet flow on ingress and egress.

#### Metro Ethernet Routing Switch 8600 R module packet flow on ingress and egress

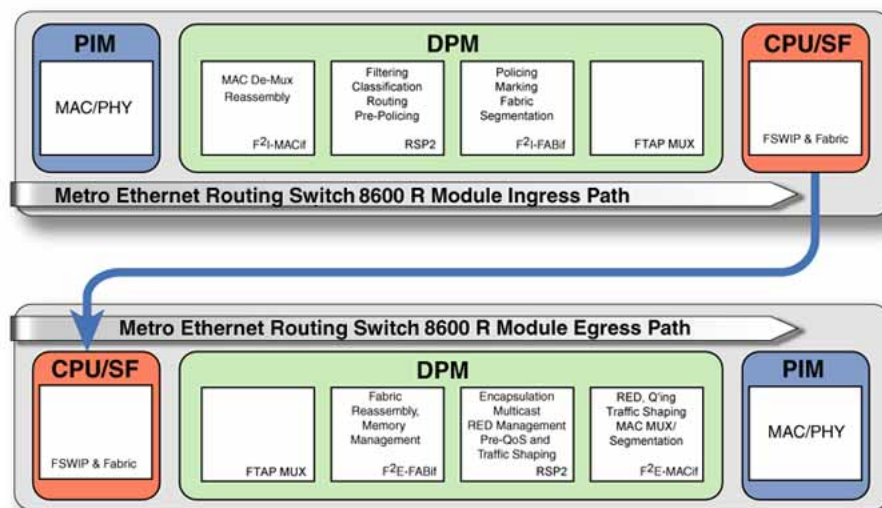

The ingress RSP2 performs lookups, filtering and classification operations, and modifies the IP and MAC headers within the body of the packet to reflect routing and switching decisions.

The RSP2 determines the information the fabric needs to carry the packet to the correct egress point and determines the physical egress port. As part of the lookup process, the RSP2 may also determine and record the egress queue ID and pass it to the egress RSP2.

Encapsulation is the most significant operation that the egress RSP2 performs. To specify the egress queue, the queuing and traffic shaping functions use:

- encapsulation information from the egress RSP2
- MAC and IP packet headers
- Quality of Service (QoS) bits

The F2E egress ASIC supports the FFE QoS, including the functions of random early drop, queuing and selection, traffic shaping, and communicating to other similar R modules. Similarly, the F2I ingress ASIC provides packet policing and marking.

Each DPM also consists of the following:

- One Fast TAPmux (FTAP) interface to the Metro Ethernet Routing Switch 8600 Switch Fabric Modules
- One Feedback Output Queue Manager (FOQ) Field-Programmable Gate Array (FPGA)

The FTAP ASIC connects each DPM to the CPU/Switch Fabric modules through the Metro Ethernet Routing Switch 8600 switching backplane.

The FOQ Management system collects information about the state of queues, packet storage elements, and the fabric. This information is available to the F2I at the point at which packets are segmented for entry to the fabric. When congestion exists, Metro Ethernet Routing Switch 8600 modules with a BFM (pre-E, E, and M modules) use fabric feedback information only at this point to drop packets.

The FOQ mechanism also provides information about the state of each of the egress queues and on the fullness of the F2E reassembly function buffers and queues. The F2E reports this information to the FOQ Manager FPGA on each module. The constellation of these FOQ FPGAs (one per DPM) drives a shared backplane bus that each FPGA senses. Therefore, each R module has pertinent information about the state of all other R modules in the system.

## M mode configuration requirements

M mode supports the Metro Ethernet Routing Switch 8600 M module feature set. Full support of M mode requires the following configuration conditions:

- The chassis must include at least one 8691omSF CPU module.

- All modules installed in the chassis must minimally support 128 000 table entries. M modules (8632TXM, 8648TXM, 8608GBM, 8608GTM, 8683POSM, 8672ATME, 8672ATMM, 8681XLR, and 8681XLW modules) support 128 000 table entries.
- M mode must be enabled.

If you enable M mode and one or more of the modules installed in the chassis is an E module (32 000 table entries), the E modules become disabled. This protects the system forwarding tables from losing entries. For information about enabling or disabling M mode, see *Managing Platform Operations* (315545-E).

If your system has M modules, E modules, or pre-E modules, see *Managing Platform Operations* (315545-E) for information about how to configure the switch to boot in the desired mode.

### R mode configuration requirements

R mode supports the Metro Ethernet Routing Switch 8600 R module feature set. Full support of R mode requires the following configuration conditions:

- The system must include only R modules. You can have a system with a mix of R, M, E, or pre-E modules configured in R mode. However, the M, E, or pre-E modules are not enabled. For information about configuring R modules in R mode, see *Managing Platform Operations* (315545-E).
- The system must include at least one 8692omSF CPU module. R modules do not boot with the 8691omSF CPU module.
- R modules require Metro Ethernet Routing Switch 8600 Release 4.0 or later.
- R mode must be enabled. For information about enabling R mode, see *Managing Platform Operations* (315545-E).

If the system is currently in default mode or M mode with CPU/SF 1 as the master and CPU/SF 2 as the standby, and you enable R mode on CPU/SF 1, save the configuration and reboot, CPU/SF 2 comes up as the master and CPU/SF 1 as the standby. If you then enable R mode on the new master (CPU/SF 2), the standby (CPU/SF 1) goes offline and remains offline.

For information about how to configure QoS, Filters, Policing, and Shaping on R modules, see *Nortel Metro Ethernet Routing Switch 8600 Configuration — QoS and Traffic Filters* (NN46220-508).



## ESM 8668 Metro Ethernet Services Module

The ESM 8668 Metro Ethernet Services Module (Metro ESM 8668) provides eight 1000Base SFP Gigabit Ethernet ports. The Metro ESM 8668 has the same architecture as the Metro Ethernet Routing Switch 8600 interface modules, but also contains an additional network processor in the data path of each of the eight Ethernet ports.

The heart of the ESM 8668 is the flexible network processor. The network processor contains four packet processing engines, each running at 400 megahertz (MHz). This architecture provides the flexibility, memory and processing power to:

- Implement a highly scalable and feature rich Ethernet VPN solution.
- Enable the highly resilient 50 millisecond (ms) Gigabit Ethernet access ring solution with the Ethernet Services Unit (ESU) 18x0 product family.
- Allow future feature enhancements through software upgrades.

See "[ESM 8668 Metro Ethernet Services Module](#)" (page 49) for a full description of the Metro ESM 8668.

## 8608GBE and 8608GBM modules

Both the 8608GBE and 8608GBM modules ("[8608GBE/8608GBM module](#)" (page 25)) provide eight bays for installing Gigabit interface converters (GBIC). You can use the ports on the GBICs to make riser connections, server attachments, or interswitch links.

### 8608GBE/8608GBM module

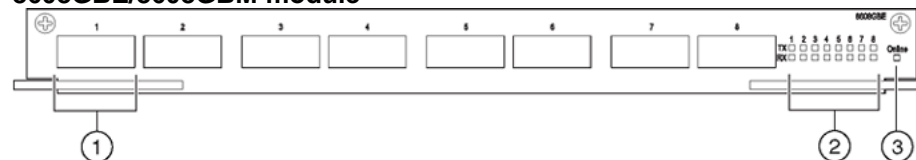

- 1 = GBIC bay  
2 = Port link LEDs  
3 = Module Online LED

9717EC

Nortel qualified the GBICs listed in "[8608GBE and 8608GBM qualified GBICs](#)" (page 25) for use in the 8608GBE and 8608GBM modules:

### 8608GBE and 8608GBM qualified GBICs

GBIC order number	GBIC type
AA1419001	1000BaseSX
AA1419002	1000BaseLX
AA1419003	1000BaseXD

GBIC order number	GBIC type
AA1419004	1000BaseZX
AA1419041	1000BaseT
AA1419017-9024	CWDM wavelengths 1470nm-1610nm

Only GBICs that Nortel qualified are supported for use in the 8608GBE Module. GBICs that Nortel did not qualify can operate within the module, but were not tested for power draw, electromagnetic interference, and interoperability.

For more information about the GBICs and instructions for installing them, see *Nortel Installation — SFP, XFP, and GBIC Hardware Components* (NN46225-301).

"8608GBE/8608GBM module LEDs" (page 26) shows the location of the 8608GBE and 8608GBM module LEDs.

#### 8608GBE/8608GBM module LEDs

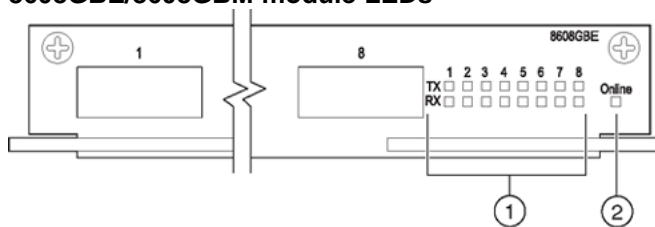

1 = Port TX and RX LEDs  
2 = Module Online LED

9718EB

"8608GBE/8608GBM module LEDs" (page 26) describes the 8608GBE and 8608GBM module LEDs.

#### 8608GBE/8608GBM module LEDs

Type	Label	Color/State	Meaning
Port	TX	Green/Blinking	The port is transmitting data.
		Amber/Steady	A fault condition exists on the line or on the attached remote device.
		Off	The port did not detect a fault condition.
	RX	Green/Steady	The port has a link and is enabled.
		Green/Blinking	The port is receiving data.
		Amber/Steady	The port has either no optical signal or no link synchronization.
		Off	The port has signal but no link.

Type	Label	Color/State	Meaning
Module	Online	Green/Steady	The module has completed its power-on self-test and software initialization and is operating normally.
		Amber/Steady	The module failed its power-on self-test.
		Off	The switch power is off. If the switch power is on, the module is going through its power-on self-test and software initialization. A module in this state is not yet functional.

The 8608GBE module supports up to 32 000 table entries in its forwarding engine. For information about table entry characteristics, see *Network Design Guidelines* (313197-E).

The 8608GBM module is an M module and supports up to 128 000 table entries in its forwarding engine, allowing for large Layer 2 and Layer 3 configurations, including Internet routing tables. For information about table entry characteristics, see *Network Design Guidelines* (313197-E).

The Metro Ethernet Routing Switch 8600 system has three hardware operating modes:

- Default mode (32 000 table entries) supports up to 32 000 hardware records. This mode supports all modules.
- M mode (128 000 table entries) supports up to 128 000 hardware records. This mode supports M modules only.
- R mode supports up to:
  - 256 000 IP routes
  - 64 000 MAC entries
  - 32 000 Address Resolution Protocol (ARP) entries

This mode supports R modules only.

The 8608GBE module does not support R or M mode. The 8608GBM module supports R and M mode. For specific R and M mode configuration requirements, see "[R mode configuration requirements](#)" (page 24) and "[M mode configuration requirements](#)" (page 23).

## 8608GTE and 8608GTM modules

Both the 8608GTE and 8608GTM module ("[8608GTE/8608GTM module](#)" (page 28)) provide eight 1000BaseT, copper Gigabit Ethernet ports with 8-pin modular (RJ-45) connectors. Each port operates in 1000 Mb/s (1 Gb/s) full-duplex mode and supports IEEE 802.3 1998 Clause 28

autonegotiation and remote fault identification when the connected device also supports autonegotiation. Distances of up to 100 meters are obtainable with Category-5 unshielded twisted pair (UTP) cable.

**8608GTE/8608GTM module**

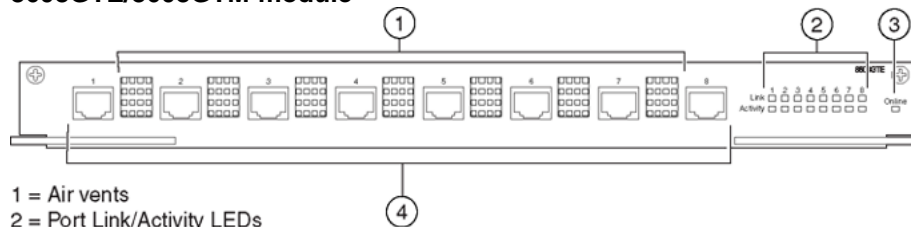

- 1 = Air vents
- 2 = Port Link/Activity LEDs
- 3 = Module Online LED
- 4 = 1000BASE-T ports

10351EB

"8608GTE/8608GTM module LEDs" (page 28) shows the location of the 8608GTE and 8608GTM Module LEDs.

**8608GTE/8608GTM module LEDs**

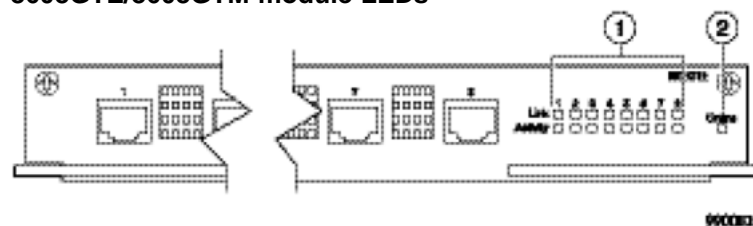

- 1 = Port Link and Activity LEDs
- 2 = Module Online LED

"8608GTE/8608GTM module LEDs" (page 28) describes the 8608GTE and 8608GTM module LEDs.

**8608GTE/8608GTM module LEDs**

Type	Label	Color/State	Meaning
Port	Link	Green/Steady	The port has established a link and is enabled.
		Amber/Steady	The port is connected, but an error condition is detected.
		Off	The port is disabled or has no link.
	Activity	Green/Blinking	The port is receiving data.  Note that as port utilization increases, this LED may blink so fast that it appears to be steady.

Type	Label	Color/State	Meaning
Module	Online	Green/Steady	The module has completed its power-on self-test and software initialization and is operating normally.
		Amber/Steady	The module failed its power-on self-test.
		Amber/Blinking	The module has been inserted into the chassis and diagnostics are running.
		Off	The switch power is off. If the switch power is on, the module is going through its power-on self-test and software initialization. A module in this state is not yet functional.

The 8608GTE module supports up to 32 000 table entries in its forwarding engine. For information about table entry characteristics, see *Network Design Guidelines* (313197-E).

The 8608GTM module is an M module and supports up to 128 000 table entries in its forwarding engine, allowing for large Layer 2 and Layer 3 configurations, including Internet routing tables. For information about table entry characteristics, see *Network Design Guidelines* (313197-E).

The Metro Ethernet Routing Switch 8600 system has three hardware operating modes:

- Default mode (32 000 table entries) supports up to 32 000 hardware records. This mode supports all modules.
- M mode (128 000 table entries) supports up to 128 000 hardware records. This mode supports M modules only.
- R mode supports up to:
  - 256 000 IP routes
  - 64 000 MAC entries
  - 32 000 ARP entries

This mode supports R modules only.

The 8608GTE module does not support R or M mode. The 8608GTM module supports R and M mode. For specific R and M mode configuration requirements, see "[R mode configuration requirements](#)" (page 24) and "[M mode configuration requirements](#)" (page 23).

## 8608SXE module

The 8608SXE module ("8608SXE module" (page 30)) supports eight 1000BaseSX ports (850 nanometer [nm] shortwave, Gigabit Ethernet) using SC type connectors for riser connections, server attachments, or interswitch links. The 8608SXE Module supports standards-based 1000 Mb/s (1 Gb/s) full-duplex operation only.

### 8608SXE module

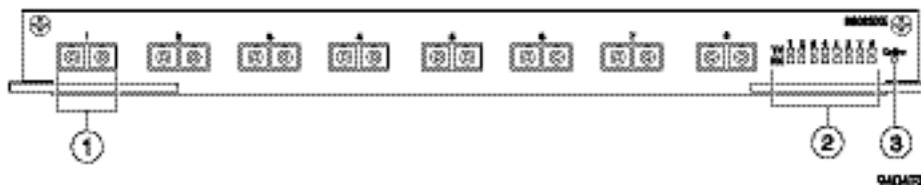

- 1 = 1000BASE-SX port
- 2 = Port TX and RX LEDs
- 3 = Module Online LED

The shortwave optical transceivers provide transmission ranges as follows:

- Up to 275 meters (m) using 62.5 micrometers ( $\mu\text{m}$ ) multimode fiber cable
- Up to 550 m using 50  $\mu\text{m}$  multimode fiber cable

"8608SXE module LEDs" (page 30) shows the location of the 8608SXE module LEDs.

### 8608SXE module LEDs

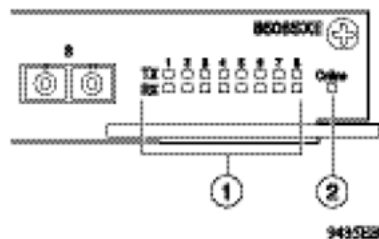

- 1 = Port TX and RX LEDs
- 2 = Module Online LED

"8608SXE module LEDs" (page 31) describes the 8608SXE module LEDs.

**8608SXE module LEDs**

Type	Label	Color/State	Meaning
Port	TX	Green/Blinking	The port is transmitting data.
		Amber/Steady	A fault condition exists on the line or on the attached remote device.
		Off	The port did not detect a fault condition.
	RX	Green/Steady	The port has established a link and is enabled.
		Green/Blinking	The port is receiving data.
		Amber/Steady	The port has either no optical signal or no link synchronization.
		Off	The port has signal but no link.
Module	Online	Green/Steady	The module has completed its power-on self-test and software initialization and is operating normally.
		Amber/Steady	The module failed its power-on self-test.
		Off	The switch power is off. If the switch power is on, the module is going through its power-on self-test and software initialization. A module in this state is not yet functional.

The 8608SXE module supports up to 32 000 table entries in its forwarding engine. For information about table entry characteristics, see *Network Design Guidelines* (313197-E).

The Metro Ethernet Routing Switch 8600 system has three hardware operating modes:

- Default mode (32 000 table entries) supports up to 32 000 hardware records. This mode supports all modules.
- M mode (128 000 table entries) supports up to 128 000 hardware records. This mode supports M modules only.
- R mode supports up to:
  - 256 000 IP routes
  - 64 000 MAC entries
  - 32 000 ARP entries

This mode supports R modules only.

The 8608SXE module does not support R or M mode.

## 8616GTE module

The 8616GTE module ("8616GTE module" (page 32)) provides 16 1000BaseT, copper Gigabit Ethernet ports with 8-pin modular (RJ-45) connectors. Each port operates in 1000 Mb/s (1 Gb/s) full-duplex mode and supports the IEEE 802.3ae standard. Distances of up to 100 meters are obtainable with Category-5 unshielded twisted pair (UTP) cable.

### 8616GTE module

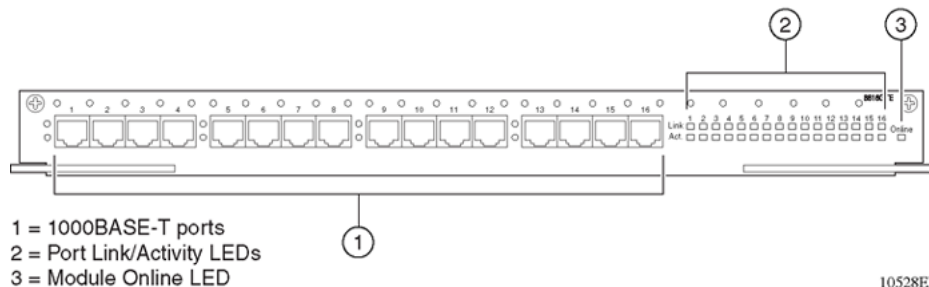

"8616GTE module LEDs" (page 32) shows the location of the 8616GTE module LEDs.

### 8616GTE module LEDs

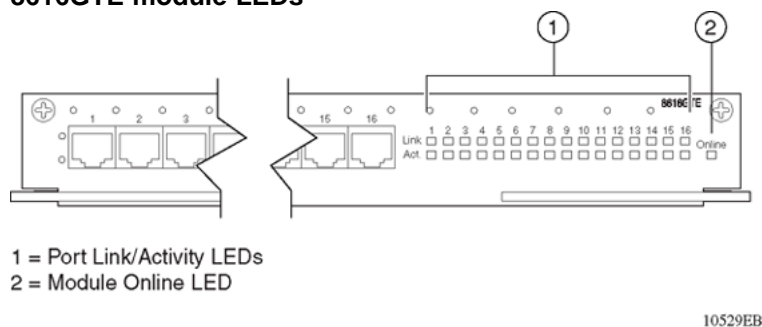

"8616GTE module LEDs" (page 32) describes the 8616GTE module LEDs.

### 8616GTE module LEDs

Type	Label	Color/State	Meaning
Port	Link	Green/Steady	The port has established a link and is enabled.
		Amber/Steady	The port is connected, but an error condition is detected.
		Off	The port is disabled or has no link.
	Activity	Green/Blinking	The port is receiving data.  Note that as port utilization increases, this LED may blink so fast that it appears to be steady.



Type	Label	Color/State	Meaning
Module	Online	Green/Steady	The module has completed its power-on self-test and software initialization and is operating normally.
		Amber/Steady	The module failed its power-on self-test.
		Amber/Blinking	The module has been inserted into the chassis and diagnostics are running.
		Off	The module power is off. If the switch power is on, the module is going through its power-on self-test and software initialization. A module in this state is not yet functional.

The 8616GTE module supports up to 32 000 table entries in its forwarding engine. For information about table entry characteristics, see *Network Design Guidelines* (313197-E).

The Metro Ethernet Routing Switch 8600 system has three hardware operating modes:

- Default mode (32 000 table entries) supports up to 32 000 hardware records. This mode supports all modules.
- M mode (128 000 table entries) supports up to 128 000 hardware records. This mode supports M modules only.
- R mode supports up to:
  - 256 000 IP routes
  - 64 000 MAC entries
  - 32 000 ARP entries

This mode supports R modules only.

The 8616GTE module does not support R or M mode.

## 8616SXE module

The 8616SXE module ("[8616SXE module](#)" (page 34)) provides 16 1000BaseSX ports (850 nm, shortwave, Gigabit Ethernet) using MT-RJ type connectors for riser connections, server attachments, or interswitch links. The 8616SXE module supports standards-based 1000Mb/s (1 Gb/s) full-duplex operation only.

**8616SXE module**



The shortwave optical transceivers provide transmission ranges as follows:

- Up to 275 m using 62.5 μm multimode fiber cable
- Up to 550 m using 50 μm multimode fiber cable

"8616SXE module LEDs" (page 34) shows the location of the 8616SXE module LEDs.

**8616SXE module LEDs**

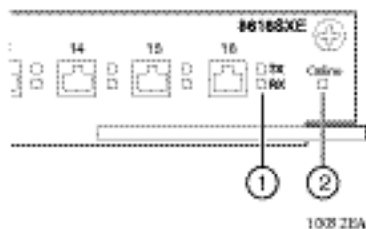

"8616SXE module LEDs" (page 34) describes the 8616SXE module LEDs.

**8616SXE module LEDs**

Type	Label	Color/State	Meaning
Port	TX	Green/Blinking	The port is transferring data.
		Off	There is no port activity.
	RX	Green/Steady	The port has established a link and is enabled.
		Green/Blinking	The port is receiving data.
		Amber/Steady	The port has either no optical signal or no link synchronization.
		Off	The port has a signal but no link.

Type	Label	Color/State	Meaning
Module	Online	Green/Steady	The module has completed its power-on self-test and software initialization and is operating normally.
		Amber/Steady	The module failed its power-on self-test.
		Off	The switch power is off. If the switch power is on, the module is going through its power-on self-test and software initialization. A module in this state is not yet functional.

The 8616SX module supports up to 32 000 table entries in its forwarding engine. For information about table entry characteristics, see *Network Design Guidelines* (313197-E).

The Metro Ethernet Routing Switch 8600 system has three hardware operating modes:

- Default mode (32 000 table entries) supports up to 32 000 hardware records. This mode supports all modules.
- M mode (128 000 table entries) supports up to 128 000 hardware records. This mode supports M modules only.
- R mode supports up to:
  - 256 000 IP routes
  - 64 000 MAC entries
  - 32 000 ARP entries

This mode supports R modules only.

The 8616SX module does not support R or M mode.

## 8624FXE module

The 8624FXE module ("[8624FXE module](#)" (page 36)) provides 24 100BaseFX ports using MT-RJ type connectors.

**8624FXE module**

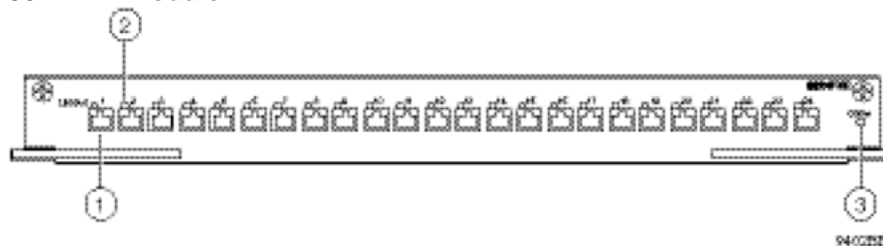

- 1 = 100BASE-FX port
- 2 = Port LED
- 3 = Module Online LED

The 24 100BaseFX ports on the 8624FXE module can operate in 100 Mb/s Fast Ethernet full-duplex mode. The optical transceivers provide transmission ranges of up to 6562 ft (2 km) using 62.5 μm multimode fiber cable or 4264 ft (1.3 km) using 50 μm multimode fiber cable.

"8624FXE module LEDs" (page 36) shows the location of the LEDs.

**8624FXE module LEDs**

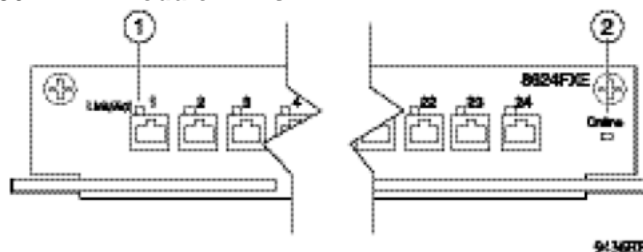

- 1 = Port Link/Activity LEDs
- 2 = Module Online LED

"8624FXE module LEDs" (page 36) describes the 8624FXE module LEDs.

**8624FXE module LEDs**

Type	Label	Color/State	Meaning
Port	Link/Act	Green/Steady	The port is connected, and the link is good.
		Green/Blinking	Data is passing through this port.
		Amber/Steady	A fault condition exists at the far end of the connection.
		Amber/Blinking	A fault condition exists at the far end of the connection, and the port is sending or receiving.
		Off	The port is not connected, or it is connected but has no link.

Type	Label	Color/State	Meaning
Module	Online	Green/Steady	The module has completed its power-on self-test and software initialization and is operating normally.
		Amber/Steady	The module failed its power-on self-test.
		Off	The switch power is off. If the switch power is on, the module is going through its power-on self-test and software initialization. A module in this state is not yet functional.

The 8624FXE module supports up to 32 000 table entries in its forwarding engine. For information about table entry characteristics, see *Network Design Guidelines* (313197-E).

The Metro Ethernet Routing Switch 8600 system has three hardware operating modes:

- Default mode (32 000 table entries) supports up to 32 000 hardware records. This mode supports all modules.
- M mode (128 000 table entries) supports up to 128 000 hardware records. This mode supports M modules only.
- R mode supports up to:
  - 256 000 IP routes
  - 64 000 MAC entries
  - 32 000 ARP entries

This mode supports R modules only.

The 8624FXE module does not support R or M mode.

## 8630GBR module

The 8630GBR module ("[8630GBR module](#)" (page 38)) provides 30 bays for installing small form factor pluggable (SFP) transceivers. You can use the ports on the SFPs to make riser connections, server attachments, or interswitch links.

The 8630GBR module is comprised of three forwarding engine lanes. Each lane supports 10 Gb/s bidirectional traffic. All 30 ports can run concurrently at 1 Gb/s.

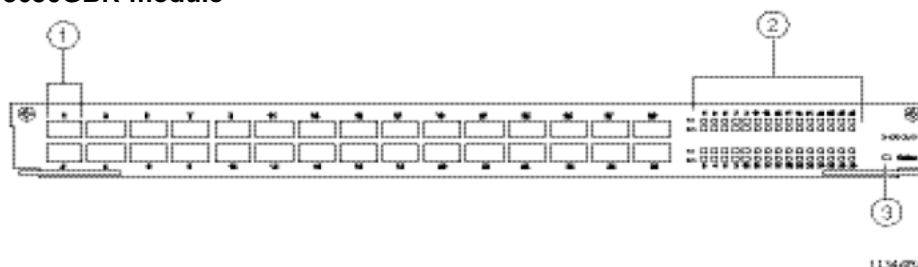
**8630GBR module**

- 1 = SFP bay
- 2 = Port TX and RX LEDs
- 3 = Module online LED

Nortel qualified the SFP transceivers listed in "[8630GBR qualified SFP transceivers](#)" (page 38) for use in the 8630GBR module:

**8630GBR qualified SFP transceivers**

SFP order number	SFP type
AA1419013	1000BaseSX
AA1419014	1000BaseSX
AA1419015	1000BaseLX
AA1419025 - AA1419032	1000BaseCWDM
AA1419033 - AA1419040	1000BaseCWDM
AA1419042	1000BaseT
AA1419071	1000Base-EX
AA1403006	10GBASE-ZR/ZW

Only SFP transceivers that Nortel qualified are supported for use in the 8630GBR module. SFP transceivers that Nortel did not qualify can operate within the module, but were not tested for power draw, electromagnetic interference, and interoperability.

For more information about the SFP transceivers and instructions for installing them, see *Nortel Installation — SFP, XFP, and GBIC Hardware Components* (NN46225-301).

**ATTENTION**

The 8630GBR module is not supported when Single Fiber Fault Detection (SFFD) is configured on a port.

"[8630GBR module LEDs](#)" (page 39) shows the location of the 8630GBR module LEDs.

## 8630GBR module LEDs

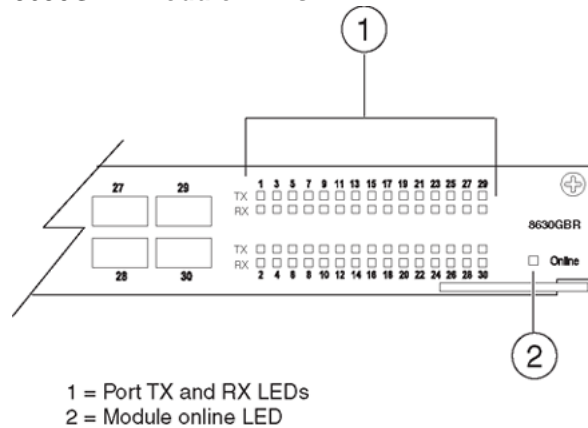

11347EA

"8630GBR module LEDs" (page 39) describes the 8630GBR module LEDs.

## 8630GBR module LEDs

Type	Label	Color/State	Meaning
Port	TX	Green/Steady	The port is enabled and has a link.
		Green/Blinking (1 second on; 1 second off)	Port disabled.
		Green/Flashing	The port is transmitting data. The LED flash rate indicates the level of activity on the link.
		Off	The port is enabled but has no link.
	RX	Green/Steady	The port is enabled and has a link.
		Green/Blinking (1 second on; 1 second off)	Port disabled.
		Green/Flashing	The port is receiving data. The LED flash rate indicates the level of activity on the link.
		Amber/Flashing	Data error.
		Off	The port is enabled but has no link.

Type	Label	Color/State	Meaning
Module	Online	Green/Steady	The module is online and is operating normally.
		Amber/Steady	The module failed its power-on self-test.
		Amber/Blinking	The module has been inserted into the chassis and diagnostics are running.
		Off	The switch power is off.

The 8630GBR module is an R module. When you use the 8630GBR ports in the Enterprise mode of operation, the 8630GBR module supports the following:

- 256 000 IP routes
- 64 000 MAC records
- 32 000 ARP records

For information about Ethernet VPN characteristics, see *Engineering Guidelines for Metro Ethernet Routing Switch 8600 and Metro Ethernet Services Unit 1800/1850*.

The Metro Ethernet Routing Switch 8600 system has three hardware operating modes:

- Default mode (32 000 table entries) supports up to 32 000 hardware records. This mode supports all modules.
- M mode (128 000 table entries) supports up to 128 000 hardware records. This mode supports M and R modules only.
- When used in the Enterprise mode of operation, R mode supports up to:
  - 256 000 IP routes
  - 64 000 MAC entries
  - 32 000 ARP entries

For information about Ethernet VPN characteristics, see *Engineering Guidelines for Metro Ethernet Routing Switch 8600 and Metro Ethernet Services Unit 1800/1850*.

R mode supports R modules only.

The 8630GBR module supports R and M mode. For specific R and M mode configuration requirements, see "[R mode configuration requirements](#)" (page 24) and "[M mode configuration requirements](#)" (page 23).



## 8632TXE and 8632TXM modules

Both the 8632TXE and 8632TXM modules ("[8632TXE/8632TXM module](#)" ([page 41](#))) provide 32 autonegotiating 10BaseT/100BaseTX ports using 8-pin modular (RJ-45) connectors. Ports operate at either 10 Mb/s or 100 Mb/s up to distances of 100 m with Category-3 or greater unshielded twisted pair (UTP) cable.

Also, the modules provide two bays for 1000BaseX Gigabit Ethernet interface connectors (GBIC).

### 8632TXE/8632TXM module

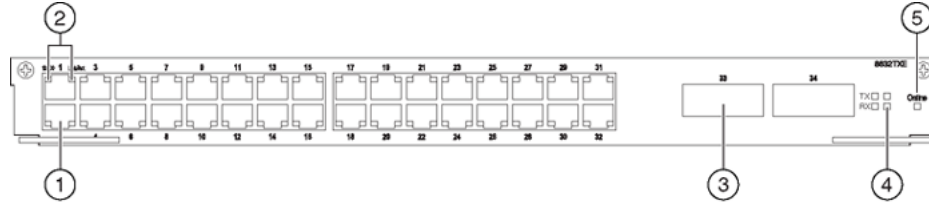

- 1 = 10/100 Mb/s port
- 2 = Port LEDs: 10/100 (speed), link/activity
- 3 = GBIC bay
- 4 = GBIC TX and RX LEDs
- 5 = Module online LED

10458EA

The 8632TXE and 8632TXM module ports support the IEEE 802.3 1998 Clause 28 autonegotiation standard. Each port can operate in full- or half-duplex mode. When a port is connected to another device that also supports the IEEE 802.3 1998 Clause 28 autonegotiation standard, the two devices negotiate the highest possible data rate and the duplex mode of operation.

Nortel qualified the GBICs listed in "[8632TXE and 8632TXM qualified GBICs](#)" ([page 41](#)) for use in the 8632TXE and 8632TXM modules:

### 8632TXE and 8632TXM qualified GBICs

GBIC order number	GBIC type
AA1419001	1000BaseSX
AA1419002	1000BaseLX
AA1419003	1000BaseXD
AA1419004	1000BaseZX
AA1419041	1000BaseT
AA1419017-9024	CWDM wavelengths 1470nm-1610nm

Only GBICs that Nortel qualified are supported for use in the 8632TXE and 8632TXM modules. GBICs that Nortel did not qualify may operate within these modules, but have not been tested for power draw, electromagnetic interference, and interoperability.

For more information about the GBICs and instructions for installing them, see *Nortel Installation — SFP, XFP, and GBIC Hardware Components* (NN46225-301).

"8632TXE/8632TXM module LEDs" (page 42) shows the location of the 8632TXE and 8632TXM module LEDs.

**8632TXE/8632TXM module LEDs**

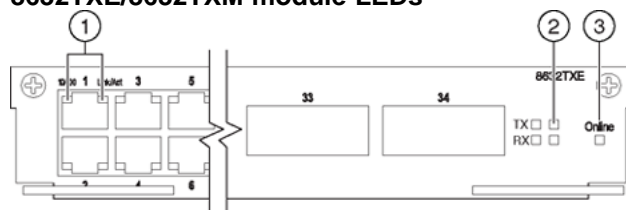

- 1 = Port LEDs: 10/100 (speed), link/activity
- 2 = GBIC TX and RX LEDs
- 3 = Module online LED

10459EA

"8632TXE/8632TXM module LEDs" (page 42) describes the 8632TXE and 8632TXM module LEDs.

**8632TXE/8632TXM module LEDs**

Type	Label	Color/State	Meaning
Module	Online	Green/Steady	The module has completed its power-on self-test and software initialization and is operating normally.
		Amber/Steady	The module failed its power-on self-test.
		Off	The switch power is off. If the switch power is on, and the module is performing its power-on self-test and software initialization. A module in this state is not yet functional.

Type	Label	Color/State	Meaning
Port	10/100	Green/Steady	The port is operating at 100 Mb/s.
		Off	The port is operating at 10 Mb/s.
	Link/Act	Green/Steady	The port is connected, and the link is good.
		Green/Blinking	Data is passing through this port.
		Off	The port is disabled or has no link.
GBIC	TX	Green/Blinking	The port is transmitting data.
		Amber/Steady	A fault condition exists on the line or on the attached remote device.
		Off	The port did not detect a fault condition.
	RX	Green/Steady	The port has a link and is enabled.
		Green/Blinking	The port is receiving data.
		Amber/Steady	The port has either no optical signal or no link synchronization.
		Off	The port has a signal but no link.

The 8632TXE module supports up to 32 000 table entries in its forwarding engine. For information about table entry characteristics, see *Network Design Guidelines* (313197-E).

The 8632TXM module is an M module and supports up to 128 000 table entries in its forwarding engine, allowing for large Layer 2 and Layer 3 configurations, including Internet routing tables. For information about table entry characteristics, see *Network Design Guidelines* (313197-E).

The Metro Ethernet Routing Switch 8600 system has three hardware operating modes:

- Default mode (32 000 table entries) supports up to 32 000 hardware records. This mode supports all modules.
- M mode (128 000 table entries) supports up to 128 000 hardware records. This mode supports M modules only.
- R mode supports up to:
  - 256 000 IP routes
  - 64 000 MAC entries
  - 32 000 ARP entries

This mode supports R modules only.

The 8632TXE module does not support R or M mode. The 8632TXM module supports R and M mode. For specific R and M mode configuration requirements, see "[R mode configuration requirements](#)" (page 24) and "[M mode configuration requirements](#)" (page 23).

## 8648GTR module

The 8648GTR module ("[8648GTR module](#)" (page 44)) provides 48 10/100/1000BaseTX ports using 8-pin module (RJ-45) connectors. Each port operates either at 10 Mb/s, 100 Mb/s, or 1000 Mb/s (1 Gb/s) and supports the IEEE 802.3ab standard. You can obtain distances of up to 100 meters with category-5 unshielded twisted pair (UTP) cable.

### 8648GTR module

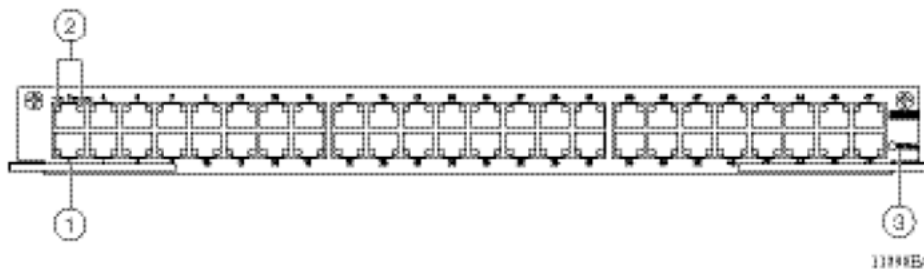

- 1 = 10/100/1000BASE-T port
- 2 = Port LEDs: 10/100/1000 (speed) Link/Activity
- 3 = Module Online LED

The 8648GTR module ports supports the IEEE 802.3 1998 Clause 28 autonegotiation standard. Each port can operate in full- or half-duplex mode. When a port is connected to another device that also supports the IEEE 802.3 1998 Clause 28 autonegotiation standard, the two devices negotiate the highest possible data rate and the duplex mode of operation.

"[8648GTR module LEDs](#)" (page 44) shows the location of the 8648GTR module LEDs.

### 8648GTR module LEDs

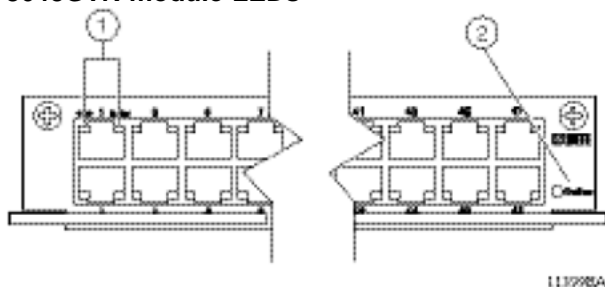

- 1 = Port LEDs: 10/100/1000 (speed) and Link/Activity
- 2 = Module Online LED

"8648GTR module LEDs" (page 45) describes the 8648GTR module LEDs.

#### 8648GTR module LEDs

Type	Label	Color/State	Meaning
Port	10/100/1000	Green/Steady	The port is operating at 1000 Mb/s.
		Amber/Steady	The port is operating at 100 Mb/s.
		Off	The port is operating at 10 Mb/s.
	Link/Activity	Amber/Blinking	Error condition.
		Green/Steady	The port is connected, and the link is good.
		Green/Blinking	Data is passing through the port. The blink rate indicates the level of link activity.
		Amber/Steady	The port is administratively disabled.
		Off	The port has no link.
	Module	Online	Green/Steady
Amber/Steady			Interim boot state, nonoperational.
Amber/Blinking			The module failed to boot.
Off			The switch power is off. If the switch power is on, the module is going through its power-on self-test and software initialization. A module in this state is not yet functional.

The 8648GTR is an R module. When 8648GTR ports are used in the Enterprise mode of operation, it supports the following:

- 256 000 IP routes
- 64 000 MAC records
- 32 000 ARP records

For information about Ethernet VPN characteristics, see *Engineering Guidelines for Metro Ethernet Routing Switch 8600 and Metro Ethernet Services Unit 1800/1850*.

The Metro Ethernet Routing Switch 8600 system has three hardware operating modes:

- Default mode (32 000 table entries) supports up to 32 000 hardware records. This mode supports all modules.
- M mode (128 000 table entries) supports up to 128 000 hardware records. This mode supports M and R modules only.
- When used in the Enterprise mode of operation, R mode supports up to:
  - 256 000 IP routes
  - 64 000 MAC entries
  - 32 000 ARP entries

This mode supports R modules only.

For information about Ethernet VPN characteristics, see *Engineering Guidelines for Metro Ethernet Routing Switch 8600 and Metro Ethernet Services Unit 1800/1850*.

The 8648GTR module supports R and M mode. For specific R and M mode configuration requirements, see "[R mode configuration requirements](#)" (page 24) and "[M mode configuration requirements](#)" (page 23).

## 8648TXE and 8648TXM modules

The 8648TXE and 8648TXM modules ("[8648TXE/8648TXM module](#)" (page 46)) provide 48 autonegotiating 10BaseT/100BaseTX ports using 8-pin modular (RJ-45) connectors. Ports operate either at 10 Mb/s or 100 Mb/s up to distances of 100 m with Category-3 or greater unshielded twisted pair (UTP) cable.

### 8648TXE/8648TXM module

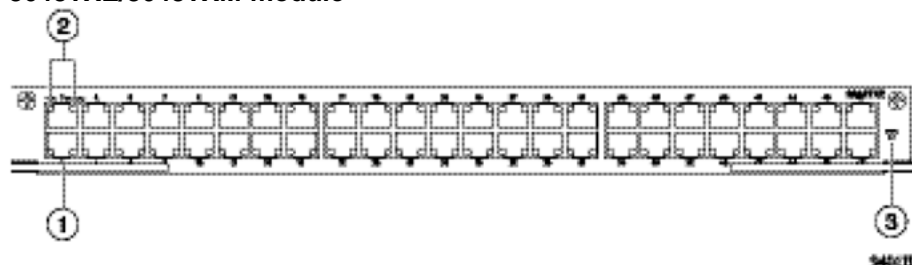

- 1 = 10/100BASE-T port
- 2 = Port LEDs: 10/100 (speed)  
Link/Activity
- 3 = Module Online LED

Both the 8648TXE and 8648TXM module ports support the IEEE 802.3 1998 Clause 28 autonegotiation standard. Each port can operate in full- or half-duplex mode. When a port is connected to another device that also supports the IEEE 802.3 1998 Clause 28 autonegotiation standard, the two devices negotiate the highest possible data rate and the duplex mode of operation.

"8648TXE/8648TXM module LEDs" (page 47) shows the location of the 8648TXE module LEDs.

#### 8648TXE/8648TXM module LEDs

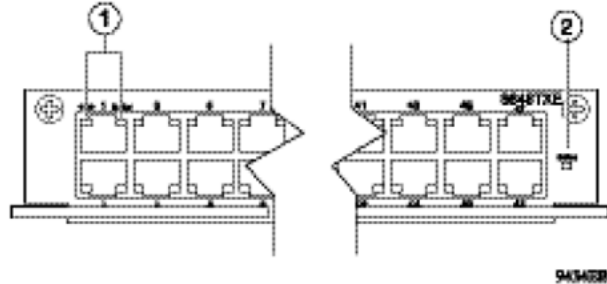

- 1 = Port LEDs: 10/100 (speed) and Link/Activity  
2 = Module Online LED

"8648TXE/8648TXM module LEDs" (page 47) describes the 8648TXE and 8648TXM module LEDs.

#### 8648TXE/8648TXM module LEDs

Type	Label	Color/State	Meaning
Port	10/100	Green/Steady	The port is operating at 100 Mb/s.
		Off	The port is operating at 10 Mb/s.
	Link/Activity	Green/Steady	The port is connected, and the link is good.
		Green/Blinking	Data is passing through the port.
	Off	The port is disabled or has no link.	

Type	Label	Color/State	Meaning
Module	Online	Green/Steady	The module has completed its power-on self-test and software initialization and is operating normally.
		Amber/Steady	The module failed its power-on self-test.
		Off	The switch power is off. If the switch power is on, the module is going through its power-on self-test and software initialization. A module in this state is not yet functional.

The 8648TXE module supports up to 32 000 table entries in its forwarding engine. For information about table entry characteristics, see *Network Design Guidelines* (313197-E).

The 8648TXM module is an M module and supports up to 128 000 table entries in its forwarding engine, allowing for large Layer 2 and Layer 3 configurations, including Internet routing tables. For information about table entry characteristics, see *Network Design Guidelines* (313197-E).

The Metro Ethernet Routing Switch 8600 system has three hardware operating modes:

- Default mode (32 000 table entries) supports up to 32 000 hardware records. This mode supports all modules.
- M mode (128 000 table entries) supports up to 128 000 hardware records. This mode supports M modules only.
- R mode supports up to:
  - 256 000 IP routes
  - 64 000 MAC entries
  - 32 000 ARP entries

This mode supports R modules only.

The 8648TXE module does not support R or M mode. The 8648TXM module supports R and M mode. For specific R and M mode configuration requirements, see "[R mode configuration requirements](#)" (page 24) and "[M mode configuration requirements](#)" (page 23).



## ESM 8668 Metro Ethernet Services Module

The ESM 8668 Metro Ethernet Services Module (Metro ESM 8668) is an intelligent edge device with 8 bays for installing small form factor pluggable (SFP) Gigabit Interface Converters (GBIC). You can use the Metro ESM 8668 module to create Metro Ethernet Services Unit (ESU) access rings, optical ethernet (OE) User-to-Network Interface (UNIs), or customer IP VLAN access points, depending on the system software configuration.

For information about installing SFPs, see *Nortel Installation — SFP, XFP, and GBIC Hardware Components* (NN46225-301).

Nortel is constantly adding new models and features to existing product lines. For a full range of SFPs and GBICs that are available from Nortel, see your Nortel sales representative.

Refer to the latest release notes for ESM 8668 capacity information and supported features.

Nortel qualified the SFP transceivers listed in "[ESM 8668 qualified SFP transceivers](#)" (page 49) for use in the ESM 8668 module:

### ESM 8668 qualified SFP transceivers

SFP order number	SFP type
AA1419071	1000BASE-EX

For more information about the SFP transceivers and instructions for installing them, see *Nortel Installation — SFP, XFP, and GBIC Hardware Components* (NN46225-301).

"[Metro ESM 8668](#)" (page 49) shows the location of the Metro ESM 8668 bays and LEDs.

### Metro ESM 8668

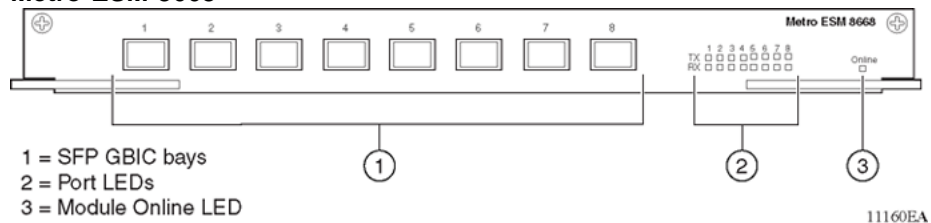

"[Metro ESM 8668 LEDs](#)" (page 49) describes the Metro ESM 8668 LEDs.

### Metro ESM 8668 LEDs

Label	Color/State	Meaning
RX	Green/Steady	The link is properly synchronized and is operational.

Label	Color/State	Meaning
	Off	No cable connection.
	Amber/Steady	The link is not properly synchronized.
	Green/Flashing	The link is passing traffic.
TX	Off	The link is not passing traffic.
	Amber/Steady	The link is not properly synchronized.
	Green/Flashing	The link is passing traffic.
Online	Green/Steady	The module is online and is load-sharing.
	Amber/Steady	The module failed diagnostic self-test.
	Off	The module is offline.

The Metro ESM 8668 supports the following:

- 100 000 MAC entries and IP address forwarding records
- 16 000 ARP entries

Note that if the chassis is configured for R mode, the ESM 8668 module is not supported.

## 8672ATME and 8672ATMM modules

Both the 8672ATME and 8672ATMM modules ("[8672ATME/8672ATMM module with an OC-12c/STM-4 MDA](#)" (page 50)) have two bays for installing ATM MDAs. These MDAs provide interface flexibility and ATM network transmission that supports RFC 1483 routed and bridged PVCs. The 8672ATME and 8672ATMM modules support Synchronous Optical Network (SONET) and Synchronous Digital Hierarchy (SDH) frame structures for data.

### 8672ATME/8672ATMM module with an OC-12c/STM-4 MDA

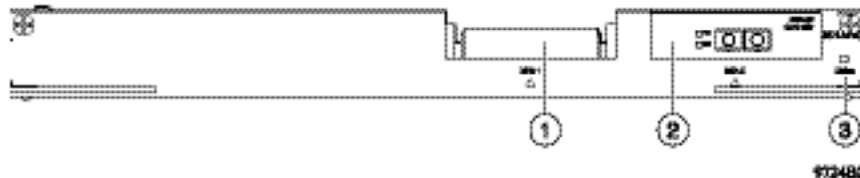

- 1 = MDA bay
- 2 = Installed MDA
- 3 = Online LED

The module requires at least one of the following MDAs:

- 1-port OC-12c/STM-4: single-mode fiber (SMF) or multimode fiber (MMF) using the SONET or SDH media
- 4-port OC-3c/STM-1: SMF or MMF using SONET or SDH media

- 2-port DS-3

For more information about the MDAs for the 8672ATME and 8672ATMM module, see *Installing Media Dependent Adapters for the 8672ATME and 8672ATMM Modules* (313071-C).

In the data center, the 8672ATME and 8672ATMM modules act as an edge device for WAN connectivity to connect an 8600 Switch to public or private ATM networks. In the wiring closet, this module provides inter-building connections for campus networks where each building is supported by frame-switched networks.

You can install up to six 8672ATME or 8672ATMM modules in one 8010 10-slot chassis. You can install up to four 8672ATME or 8672ATMM modules in one 8006 6-slot chassis. You can install up to two 8672ATME or 8672ATMM modules in a 8003 3-slot chassis.

Both the 8672ATME and 8672ATMM modules have an online LED that indicates overall status for the module. "[8672ATME/8672ATMM module LED](#)" (page 51) describes the online LED .

#### 8672ATME/8672ATMM module LED

Color/State	Meaning
Green	The module is receiving power and is ready to receive and transmit traffic.
Amber	The module is initializing and performing diagnostic self-tests.
Off	The module is offline and not receiving power.

See *Using 8672ATME and 8672ATMM Modules* (209195-G) for a description of how to configure the 8672ATME and 8672ATMM modules using the command line interface (CLI) or Device Manager.

The 8672ATME module supports up to 32 000 table entries in its forwarding engine. For information about table entry characteristics, see *Network Design Guidelines* (313197-E).

The 8672ATMM module is an M module and supports up to 128 000 table entries in its forwarding engine, allowing for large Layer 2 and Layer 3 configurations, including Internet routing tables. For information about table entry characteristics, see *Network Design Guidelines* (313197-E).

The Metro Ethernet Routing Switch 8600 system has three hardware operating modes:

- Default mode (32 000 table entries) supports up to 32 000 hardware records. This mode supports all modules.

- M mode (128 000 table entries) supports up to 128 000 hardware records. This mode supports M modules only.
- R mode supports up to:
  - 256 000 IP routes
  - 64 000 MAC entries
  - 32 000 ARP entries

This mode supports R modules only.

The 8672ATME module does not support R or M mode. The 8672ATMM module supports R and M mode. For specific R and M mode configuration requirements, see "[R mode configuration requirements](#)" (page 24) and "[M mode configuration requirements](#)" (page 23).

### 8681XLR module

The 8681XLR module ("[8681XLR module](#)" (page 52)) provides a single 10GBASELR 1310nm 10 Gigabit Ethernet serial LAN port. The 10GBASELR port (10.3 Gb/s LAN PHY) operates in full-duplex mode and provides transmission ranges of up to 10 km using 9/125  $\mu\text{m}$  single-mode fiber cable.

Note that the Metro Ethernet Routing Switch 8600 does not support the 8681XLR module.

#### 8681XLR module



"[8681XLR module LEDs](#)" (page 53) shows the location of the 8681XLR module LEDs.

Unlike other 8600 modules, the TX LED for the 8681XLR and 8681XLW modules is located below the RX LED.

## 8681XLR module LEDs

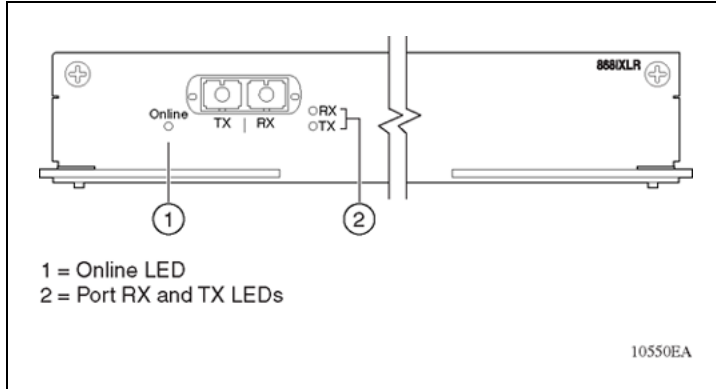

"8681XLR module LEDs" (page 53) describes the 8681XLR module LEDs.

## 8681XLR module LEDs

Type	Label	Color/State	Meaning
Port	TX	Green/Steady	The port is enabled but not transmitting data.
		Green/Blinking	The port is transmitting data.
		Off	The port transmit is disabled.
	RX	Green/Steady	The port has a link and is enabled.
		Green/Blinking	The port is receiving data.
		Amber/Steady	The cable is disconnected, the port is disabled, or the link is down.
Module	Online	Green/Steady	The module has completed its power-on self-test and software initialization and is operating normally.
		Amber/Steady	The module slot is disabled.
		Off	The switch power is off. If the switch power is on, the module is going through its power-on self-test and software initialization. A module in this state is not yet functional.

See *Using Metro Ethernet Routing Switch 8600 10 Gigabit Ethernet Modules (315893-E)* for a description of how to configure the 8681XLR module using the command line interface (CLI) or Device Manager.

The 8681XLR module supports up to 128 000 table entries in its forwarding engine, allowing for large Layer 2 and Layer 3 configurations, including Internet routing tables. For information about table entry characteristics, see *Network Design Guidelines* (313197-E).

The Metro Ethernet Routing Switch 8600 system has three hardware operating modes:

- Default mode (32 000 table entries) supports up to 32 000 hardware records. This mode supports all modules.
- M mode (128 000 table entries) supports up to 128 000 hardware records. This mode supports M modules only.
- R mode supports up to:
  - 256 000 IP routes
  - 64 000 MAC entries
  - 32 000 ARP entries

This mode supports R modules only.

The 8681XLR module supports R and M mode. For specific R and M mode configuration requirements, see "[R mode configuration requirements](#)" (page 24) and "[M mode configuration requirements](#)" (page 23).

### 8681XLW module

The 8681XLW module ("[8681XLW module](#)" (page 54)) provides a single 10GBaseLW 1310nm 10 Gigabit Ethernet serial WAN port. The 10GBaseLW port (9.95 Gb/s WAN PHY) operates in full-duplex mode and provides a transmission range of up to 10 km using 9/125  $\mu\text{m}$  single-mode fiber cable.

Note that the Metro Ethernet Routing Switch 8600 does not support the 8681XLW module.

#### 8681XLW module

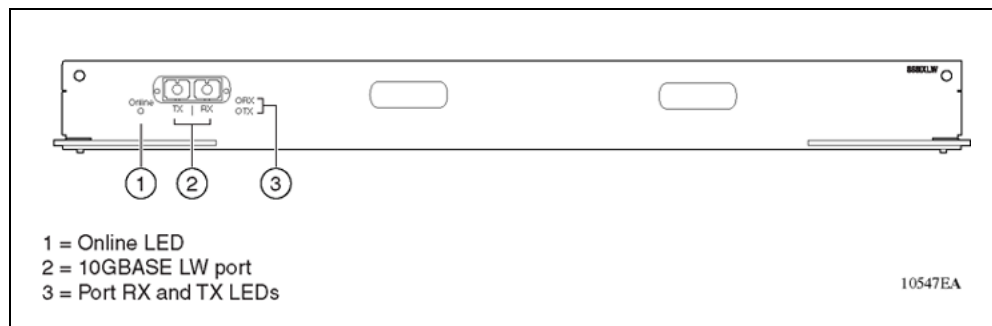

"8681XLW module LEDs" (page 55) shows the location of the 8681XLW module LEDs.

Unlike other 8600 modules, the TX LED for the 8681XLR and 8681XLW modules is located below the RX LED.

### 8681XLW module LEDs

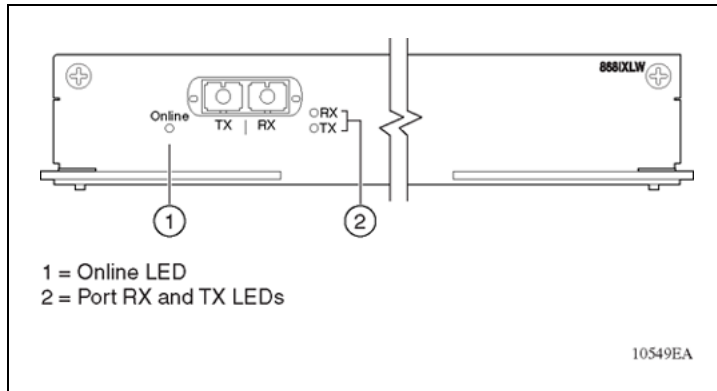

"8681XLW module LEDs" (page 55) describes the 8681XLW module LEDs.

### 8681XLW module LEDs

Type	Label	Color/State	Meaning
Port	TX	Green/Blinking	The port is transmitting data.
		Green/Steady	The port is enabled but not transmitting data.
		Off	The port did not detect a fault condition.
	RX	Green/Steady	The port has a link and is enabled.
		Green/Blinking	The port is receiving data.
		Amber/Steady	The cable is disconnected, the port is disabled, the link is down, or SONET errors are detected.
Module	Online	Green/Steady	The module has completed its power-on self-test and software initialization and is operating normally.
		Amber/Steady	The module slot is disabled.
		Off	The switch power is off. If the switch power is on, the module is going through its power-on self-test and software initialization. A module in this state is not yet functional.

See *Using Metro Ethernet Routing Switch 8600 10 Gigabit Ethernet Modules* (315893-E) for a description of how to configure the 8681XLW module using the command line interface (CLI) or Device Manager.

The 8681XLW module supports up to 128 000 table entries in its forwarding engine, allowing for large Layer 2 and Layer 3 configurations, including Internet routing tables. For information about table entry characteristics, see *Network Design Guidelines* (313197-E).

The Metro Ethernet Routing Switch 8600 system has three hardware operating modes:

- Default mode (32 000 table entries) supports up to 32 000 hardware records. This mode supports all modules.
- M mode (128 000 table entries) supports up to 128 000 hardware records. This mode supports M modules only.
- R mode supports up to:
  - 256 000 IP routes
  - 64 000 MAC entries
  - 32 000 ARP entries

This mode supports R modules only.

The 8681XLW module supports R and M mode. For specific R and M mode configuration requirements, see "[R mode configuration requirements](#)" (page 24) and "[M mode configuration requirements](#)" (page 23).

## 8683POSM module

The 8683POSM module ("[8683POSM module with an OC-12c/STM-4 MDA](#)" (page 56)) has three bays for installing POS media dependent adapters (MDAs). These MDAs provide MAN/WAN support by allowing access to SONET services in the metropolitan area. You can connect multiple campuses in a single metropolitan area without compromising performance or increasing complexity. You can install up to four 8683POSM modules in one 8010 10-slot chassis (four in a 8006 6-slot chassis, and two in a 8003 3-slot chassis).

### 8683POSM module with an OC-12c/STM-4 MDA

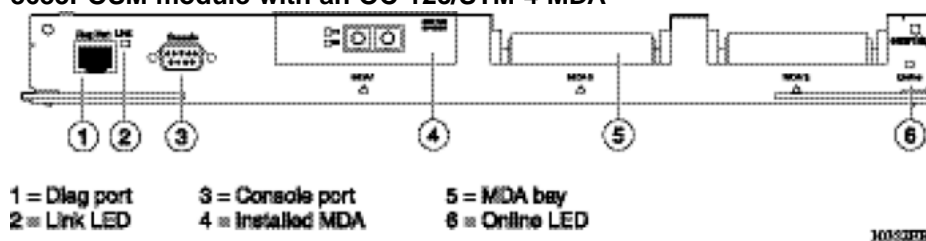



To operate, each module requires at least one of the following MDAs:

- 1-port OC-12c/STM-4: SMF or MMF using SONET media
- 2-port OC-3c/STM-1: SMF or MMF using SONET media

The 8683POSM module supports a mixture of OC-3c/STM-1 and OC-12c/STM-4 lines. For example, you can install an OC-12c/STM-4 MDA in the first bay and OC-3c/STM-1 MDAs in the two remaining bays. This module supports up to six I/O OC-3c/STM-1 lines and up to three I/O OC-12c/STM-4 lines.

The 8683POSM module has an online LED that indicates overall status for the module. "[8683POSM module LED](#)" (page 57) describes the online LED.

#### 8683POSM module LED

Color/State	Meaning
Green	The module is receiving power and is ready to receive and transmit traffic.
Amber	The module is initializing and performing diagnostic self-tests.
Off	The module is offline and is not receiving power.

See *Using the 8683POSM Module* (209564-C) for a description of how to configure the 8683POSM module using the command line interface (CLI) or Device Manager.

The 8683POSM module is an M module and supports up to 128 000 table entries in its forwarding engine, allowing for large Layer 2 and Layer 3 configurations, including Internet routing tables. For information about table entry characteristics, see *Network Design Guidelines* (313197-E).

The Metro Ethernet Routing Switch 8600 system has three hardware operating modes:

- Default mode (32 000 table entries) supports up to 32 000 hardware records. This mode supports all modules.
- M mode (128 000 table entries) supports up to 128 000 hardware records. This mode supports M modules only.
- R mode supports up to:
  - 256 000 IP routes
  - 64 000 MAC entries
  - 32 000 ARP entries

This mode supports R modules only.

The 8683POSM module supports R and M mode. For specific R and M mode configuration requirements, see "[R mode configuration requirements](#)" (page 24) and "[M mode configuration requirements](#)" (page 23).

## 8683XLR module

The 8683XLR module ("[8683XLR module](#)" (page 58)) provides three bays for installing 10 Gigabit Ethernet small form factor pluggable (XFP) transceivers. The 10GBaseR port (10.3 Gb/s LAN PHY) operates in full-duplex mode and provides transmission ranges of up to 10 km using 9/125  $\mu\text{m}$  single-mode fiber cable.

The 8683XLR module is comprised of three forwarding engine lanes. Each lane supports 10 Gb/s bidirectional traffic. All three ports may run concurrently at 10 Gb/s.

### ATTENTION

Nortel recommends that you install only one 10GBaseZR/ZW on the 8683XLR and 8683XZR due to cooling limitations. Nortel further recommends that you install the XFP only in port 1. You can install a 10GBaseSR, -LR/LW, or -ER/EW in one or both of the remaining ports.

### 8683XLR module

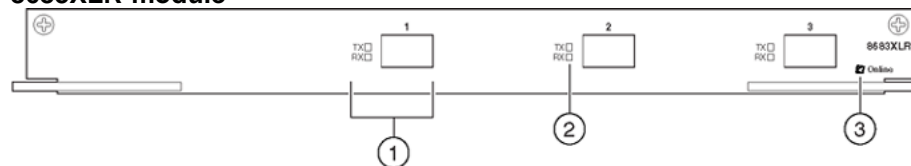

- 1 = XFP bay
- 2 = Port link LEDs
- 3 = Module Online LED

11425EA

The 8683XLR module supports up to three 10 Gigabit Ethernet small form factor pluggable (XFP) transceivers.

Although some of the XFPs are LAN/WAN (that is, LR/LW, ER/EW, ZR/ZW) this module only makes use of the LAN functionality.

Nortel qualified the XFPs listed in "[8683XLR qualified XFP transceivers](#)" (page 58).

### 8683XLR qualified XFP transceivers

XFP order number	XFP type
AA1403005	10GBaseSR
AA1403001	10GBaseLR

XFP order number	XFP type
AA1403003	10GBaseER
AA1403006	10GBaseZR

"8683XLR module LEDs" (page 59) shows the location of the 8683XLR module LEDs.

#### 8683XLR module LEDs

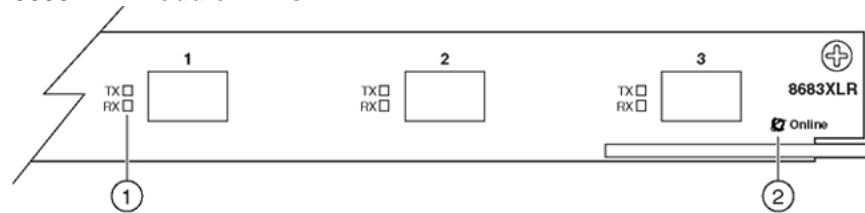

1 = Port TX and RX LEDs  
2 = Module online LED

11426EA

"8683XLR module LEDs" (page 59) describes the 8683XLR module LEDs.

#### 8683XLR module LEDs

Type	Label	Color/State	Meaning
Port	TX	Green/Steady	The port is enabled but not transmitting data.
		Green/Blinking	The port is transmitting data.
		Off	The cable is disconnected or the link is down.
	RX	Green/Steady	The port has a link and is enabled.
		Green/Blinking	The port is receiving data.
		Off	The cable is disconnected or the link is down.
	TX & RX	Both Blinking Green	The port is disabled.

Type	Label	Color/State	Meaning
Module	Online	Green/Steady	The module has completed its power-on self-test and software initialization and is operating normally.
		Amber/Steady	The module slot is disabled or in the process of software initialization.
		Off	The switch power is off or there is no power to the card. If the switch power is on, the module is going through its power-on self-test and software initialization. A module in this state is not yet functional.

See *Using Metro Ethernet Routing Switch 8600 10 Gigabit Ethernet Modules (315893-E)* for a description of how to configure the 8683XLR module using the command line interface (CLI) or Device Manager.

The Ethernet Routing Switch 8683XLR module is an R module. When 8683XLR ports are used in the Enterprise mode of operation, it supports the following:

- 256 000 IP routes
- 64 000 MAC records
- 32 000 ARP records

For information about Ethernet VPN characteristics, see *Engineering Guidelines for Metro Ethernet Routing Switch 8600 and Metro Ethernet Services Unit 1800/1850*.

The Metro Ethernet Routing Switch 8600 system has three hardware operating modes:

- Default mode (32 000 table entries) supports up to 32 000 hardware records. This mode supports all modules.
- M mode (128 000 table entries) supports up to 128 000 hardware records. This mode supports M and R modules only.
- When used in the Enterprise mode of operation, R mode supports up to:
  - 256 000 IP routes
  - 64 000 MAC entries
  - 32 000 ARP entries

For information about Ethernet VPN characteristics, see *Engineering Guidelines for Metro Ethernet Routing Switch 8600 and Metro Ethernet Services Unit 1800/1850*.

R mode supports R modules only.

The 8683XLR module supports R and M mode. For specific R and M mode configuration requirements, see "[R mode configuration requirements](#)" (page 24) and "[M mode configuration requirements](#)" (page 23).

## 8683XZR module

The 868XZR module supports both LAN and WAN operation (10.3 Gb/s LAN PHY and 9.9 Gb/s WAN PHY). The 8683XZR module ("[8683XZR module](#)" (page 61)) provides three bays for installing 10 Gigabit Ethernet small form factor pluggable (XFP) transceivers. The port operates in full-duplex mode.

The 8683XZR module includes three forwarding engine lanes. Each lane supports 10 Gb/s bidirectional traffic. All three ports can run concurrently at 10 Gb/s.

### ATTENTION

Nortel recommends that you install only one 10GBaseZR/ZW on the 8683XLR and 8683XZR due to cooling limitations. Nortel further recommends that you install the XFP only in port 1. You can install a 10GBaseSR, -LR/LW, or -ER/EW in one or both of the remaining ports.

### 8683XZR module

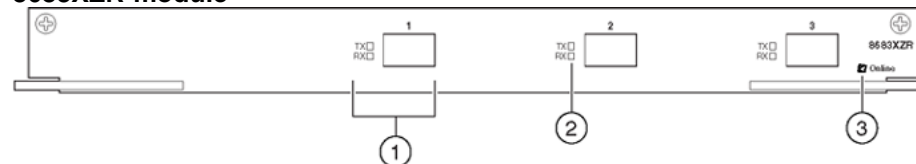

- 1 = XFP bay
- 2 = Port link LEDs
- 3 = Module Online LED

The 8683XZR module supports up to three 10 Gigabit Ethernet small form factor pluggable (XFP) transceivers.

Nortel qualified the XFPs listed in "[8683XZR qualified XFPs](#)" (page 61).

### 8683XZR qualified XFPs

XFP order number	XFP type
AA1403005	10GBaseSR/SW
AA1403001	10GBaseLR/LW
AA1403003	10GBaseER/EW
AA1403006	10GBaseZR/ZW

"8683XZR Module LEDs" (page 62) shows the location of the 8683XZR Module LEDs.

#### 8683XZR Module LEDs

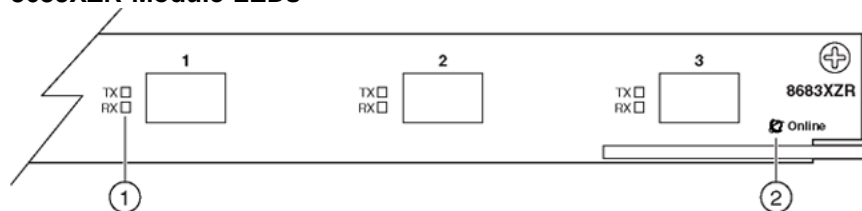

1 = Port TX and RX LEDs  
2 = Module online LED

" 8683XZR Module LEDs" (page 62) describes the 8683XZR Module LEDs.

#### 8683XZR Module LEDs

Type	Label	Color/State	Meaning
Port	TX	Green/Steady	The port is enabled but not transmitting data.
		Green/Blinking	The port is transmitting data.
		Off	The port is disabled.
	RX	Green/Steady	The port has a link and is enabled.
		Green/Blinking	The port is receiving data.
		Amber/Steady	The cable is disconnected, the port is disabled, or the link is down.
Module	Online	Green/Steady	The module completed its power-on self-test and software initialization and is operating normally.
		Amber/Steady	The module slot is disabled.
		Off	The switch power is off. If the switch power is on, the module is going through its power-on self-test and software initialization. A module in this state is not yet functional.

See *Using Metro Ethernet Routing Switch 8600 10 Gigabit Ethernet Modules (315893-E)* for a description of how to configure the 8683XZR Module using the command line interface (CLI) or Device Manager.

The 8683XZR module is an R module. When 8683XZR ports are used in the Enterprise mode of operation, it supports the following:

- 256 000 IP routes
- 64 000 MAC records

- 32 000 ARP records

For information about Ethernet VPN characteristics, see *Engineering Guidelines for Metro Ethernet Routing Switch 8600 and Metro Ethernet Services Unit 1800/1850*.

The Metro Ethernet Routing Switch 8600 system has three hardware operating modes:

- Default mode (32 000 table entries) supports up to 32 000 hardware records. This mode supports all modules.
- M mode (128 000 table entries) supports up to 128 000 hardware records. This mode supports M and R modules only.
- When used in the Enterprise mode of operation, R mode supports up to:
  - 256 000 IP routes
  - 64 000 MAC entries
  - 32 000 ARP entries

For information about Ethernet VPN characteristics, see *Engineering Guidelines for Metro Ethernet Routing Switch 8600 and Metro Ethernet Services Unit 1800/1850*.

R mode supports R modules only.

The 8683XZR module supports R and M mode. For specific R and M mode configuration requirements, see "[R mode configuration requirements](#)" (page 24) and "[M mode configuration requirements](#)" (page 23).

## 8691omSF module

The 8691omSF module ("[8691omSF module](#)" (page 63)) provides the core switching fabric for the Metro Ethernet Routing Switch 8600, as well as a CPU subsystem and a real-time clock. The core switching fabric switches all traffic through the routing switch modules. The CPU subsystem manages the routing switch fabric and the other I/O modules.

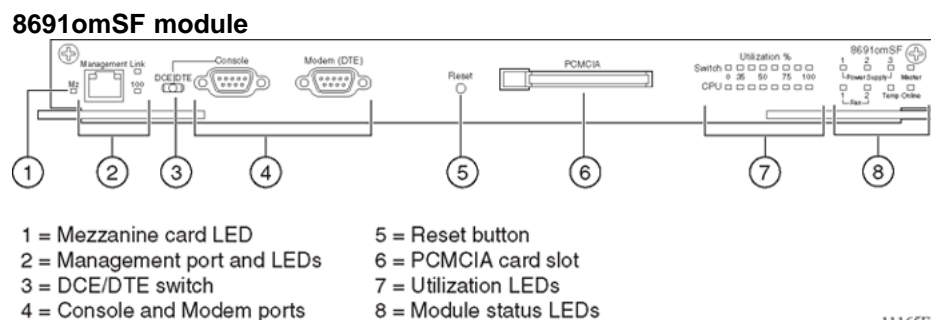

11165EB

The 8691SF/256 (DS1404090) is functionally identical to the 8691SF except it has 256 MB of synchronous dynamic random access memory (SDRAM) installed. The 8691SF/256 is identified by the front panel model number label in the upper right corner as 8691SF/256.

You can use the 8691SF as a Metro Ethernet switch fabric with the appropriate memory upgrade. See *Installing a CPU Memory Upgrade* (314832-D) for instructions for upgrading CPU memory.

The 8691omSF module consists of a printed circuit board with status LEDs, a management port, a DCE/DTE switch for the console port, a console port, a modem port, a reset button, and a PC Card slot.

The CPU subsystem uses a PowerPC CPU and has 256 MB of SDRAM. The 8691omSF module contains 16 MB of onboard flash memory used to store the image file, and 2 MB of boot memory (ROM).

The routing switch fabric uses 10 MB of shared, high-speed memory. This memory buffers traffic destined for I/O modules. The switch logic allocates memory to the various switch priority queues according to traffic usage and current switch configuration.

In all 8000 series chassis other than the 8003 chassis, you can install a 8691omSF module in both slots 5 and 6 of the chassis to enable redundant operation. The redundant module in slot 6 can assume the processing duties of a failing primary 8691omSF module in slot 5.

When the 8691omSF module in slot 6 completes initialization, it relearns the routing and VLAN bridging information for the switch unless the HA-CPU flag is enabled. If HA-CPU is enabled, the static routes and ARP entries for routing are synchronized to the redundant CPU, which results in no interruption of network services.

The two 8691omSF modules share switch fabric functions for the switch. If one 8691omSF module fails, the system reverts to operation with a single 8691omSF module.

Note that when the Metro ESM 8668 module is installed, the HA-CPU flag is not supported.

["8691omSF module LEDs"](#) (page 65) shows the location of the 8691omSF module LEDs.

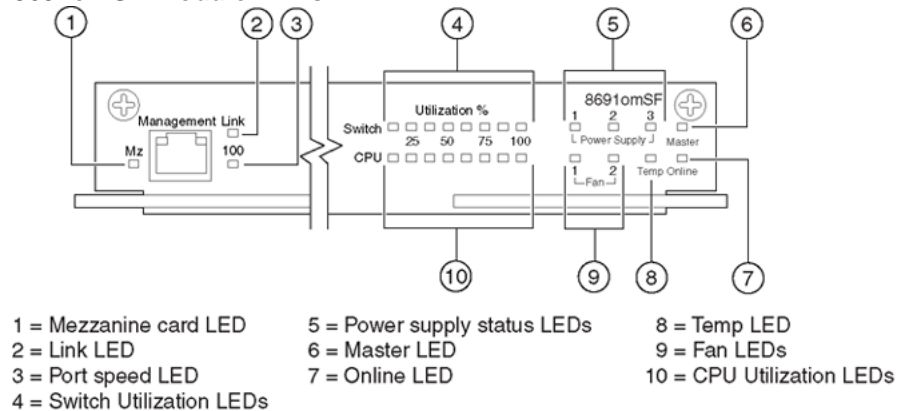

**8691omSF module LEDs**

11166EB

The Switch LEDs and the CPU LEDs serve as a bar graph to indicate card activity. The Switch bar graph increases as the switch fabric utilization increases. The CPU bar graph increases when the CPU is actively performing tasks, such as learning media access control (MAC) addresses, updating routing tables, or interacting with the device management station.

"8691omSF module LEDs" (page 65) describes the 8691omSF module LEDs.

**8691omSF module LEDs**

Label	Color/State	Meaning
Mz	N/A	Reserved for future use.
Link	Green/Steady	The management port is connected, and the link is good.
	Off	There is no link to the management port.
100	Green/Steady	The management port is operating at 100 Mb/s.
	Off	The management port is operating at 10 Mb/s.
Switch Utilization (8 LEDs)	Green	The number of lit LEDs indicates the utilization level of the switch fabric as follows: 1 LED = 10 Mb/s              5 LEDs = 10 Gb/s 2 LEDs = 100 Mb/s              6 LEDs = 20 Gb/s 3 LEDs = 1 Gb/s              7 LEDs = 40 Gb/s 4 LEDs = 5 Gb/s              8 LEDs = 64 Gb/s

Label	Color/State	Meaning
CPU Utilization (8 LEDs)	Green	The number of lit LEDs indicates the level of CPU activity as follows:
		1 LED = 12%
		2 LEDs = 24%
		3 LEDs = 36%
		4 LEDs = 48%
Power Supply 1, 2, 3	Green/Steady	The specified power supply is operating normally.
	Amber/Steady	The specified power supply has a fault.
	Off	A power supply is not present in the specified bay, or the power supply in the specified bay is not turned on.
Fan 1, 2	Green/Steady	The specified fan is operating normally.
	Amber/Steady	The specified fan has failed.
Temp	Green/Steady	The temperature is normal for switch operation.
	Amber/Steady	The temperature of the switch has exceeded the maximum operating temperature.
Master	Green/Steady	The CPU subsystem on the module is performing diagnostics.
	Green/Blinking	This module is providing active CPU functions for the switch and is the master CPU module.
	Amber/Steady	The CPU subsystem is in a fault state.
	Off	The CPU subsystem on the module is up and is in standby mode.
Online	Green/Steady	The switch fabric portion of the module is online and is load-sharing.
	Amber/Steady	The switch fabric portion of the module failed diagnostics.
	Off	The switch fabric portion of the module is offline.

### Ethernet management port

Ethernet management port on the 8691omSF module is an MDI 10/100BaseT port that allows out-of-band management of the switch using a Web browser or Device Manager. You can also establish a Telnet session to access the CLI. Use this port to connect the switch to a network management station. The Ethernet management port has its own IP address but does not switch traffic to other ports in the chassis.

Note that you use this port only as a management port. This port provides out-of-band management for the 8691omSF module.

### DCE/DTE switch

The DCE/DTE switch changes the pin assignments on the Console port. Use this switch to designate the connector as either DTE or DCE. For information about pin assignments for the Console port, see "[Console serial port](#)" (page 130).

### Serial ports

The 8691omSF module provides two serial ports for attaching modem and console devices. You can use the console port to access the 8691omSF module with a terminal using the CLI. Use the modem port to connect a standard modem for out-of-band, dial-up management. For information about pin assignments for these ports, see "[Console serial port](#)" (page 130) and "[Modem serial port](#)" (page 130).

### Reset button

Use the recessed Reset button on the module to perform a hard reset or reboot of the system.

### PC Card slot

The PC Card slot in the 8691omSF module accepts an ATA-type, SanDisk-compatible flash memory card. This memory card provides a convenient way to store switch configurations and boot images. Using a memory card, you can quickly transfer configurations and images between switches or store multiple configurations for a single switch.

Supported memory cards for the 8691omSF module include the following:

- Modem cards that are compatible with Intel 8250 or National 16552 serial ports
- LAN cards from 3COM 589, 562, or 556 equipment.

## 8692omSF module

Dual 8692omSF switch fabric modules ("[8692omSF module](#)" (page 68)) enable a maximum switch bandwidth of 512 Gb/s. Using the Split MultiLink Trunking (SMLT) protocol in the core, a redundant Metro Ethernet Routing Switch 8600 with two 8692omSF modules can provide over 1 terabit per second (Tb/s) of core switching capacity.

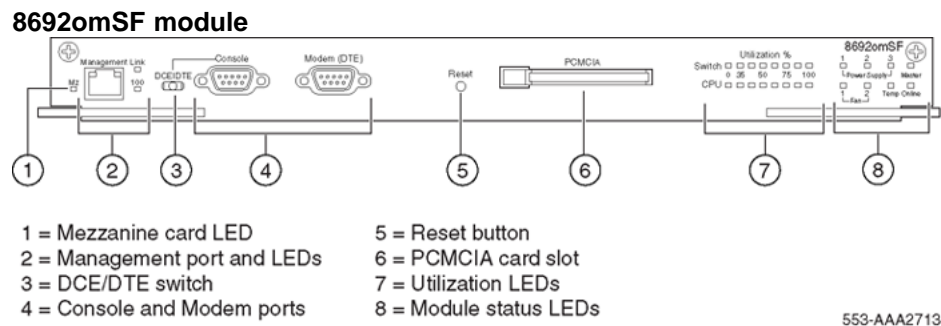

Do not use any software prior to Metro Ethernet Routing Switch 8600 Release 3.6 with the 8692omSF CPU module. For more information, see *Nortel Metro Ethernet Routing Switch 8600 Important Notice — Using the Correct Software Version for the 8692SF CPU Module (NN46220-404)*.

The 8692SF module is equivalent to the 8692omSF module. It can be used as Metro Ethernet switch fabric with the appropriate software. See *Nortel Metro Ethernet Routing Switch 8600 Important Notice — Using the Correct Software Version for the 8692SF CPU Module (NN46220-404)*.

The 8692omSF module uses a CPU similar to the PowerPC CPU of the 8691omSF. The 8692omSF CPU has 256 MB of synchronous dynamic random access memory (SDRAM) for forwarding tables, and 56 MB of onboard flash memory for configuration, image and log file storage.

The 8692omSF is capable of supporting an optional Metro Ethernet enhanced CPU daughter card. The Metro Ethernet enhanced CPU daughter card is a mezzanine daughter card consisting of dual 1 GHz PowerPC processors. Installing the daughter card on an 8692omSF module offloads processor intensive tasks from the 333 MHz processor located on the 8692omSF CPU motherboard. The Metro Ethernet enhanced CPU daughter card is required for Provider Backbone Transport (PBT) services. For installation instructions, see [Appendix "Installing the Metro Ethernet enhanced CPU daughter card" \(page 135\)](#).

The flash memory is divided into two volumes: Volume/0 has a capacity of 16 MB and Volume/1 has a capacity of 40 MB. You can use either volume to store multiple file types, however, the 8692omSF module can only use either Volume/0 or Volume/1. By default, the system can only use 16 MB on Volume/0. If you want to use 40 MB on Volume/1, refer to the procedure for upgrading the flash memory to 40 MB in *Nortel Metro Ethernet Routing Switch 8600 Upgrading — Software Release 4.1 (NN46220-402)*.

Using the SMLT protocol in the core, the Metro Ethernet Routing Switch 8600 can provide over 1 Tb/s of core switching capability.

You can install a 8692omSF module in both slots 5 and 6 of the 8006, 8010, or 8010co chassis to enable redundant operation. The redundant module in slot 6 can then assume the processing duties of a failing primary 8692omSF module in slot 5.

When the 8692omSF module in slot 6 completes initialization, it recalculates the topology information (Layer 2 including spanning tree groups (STG), Layer 3 including routing topology using Routing Information Protocol/Open Shortest Path First (RIP/OSPF) or Border Gateway Protocol (BGP)) for the switch unless High Availability mode (HA-CPU flag) is enabled. In High Availability mode, all Layer 2 information is synchronized to the redundant CPU, which results in no interruption of network services. For more information about High Availability mode, see *Managing Platform Operations* (315545-E).

The two 8692omSF modules share switch fabric functions for the switch. If one 8692omSF module fails, the system reverts to operation with a single 8692omSF module.

## LEDs

"8692omSF module LEDs" (page 69) shows the location of the 8692omSF module LEDs.

### 8692omSF module LEDs

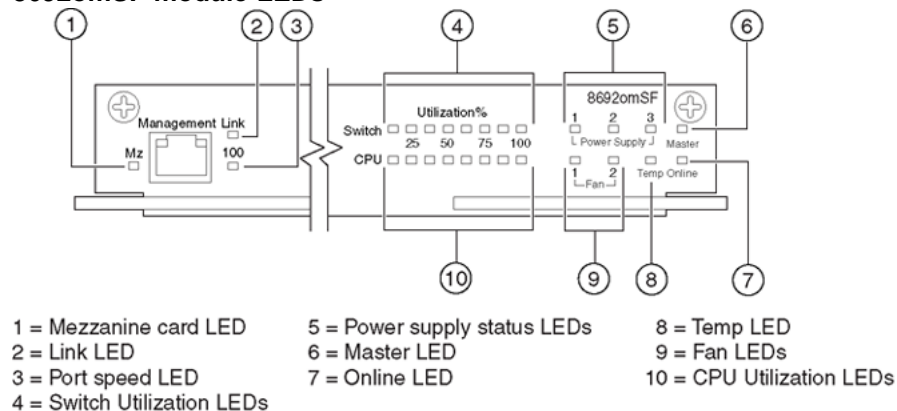

553-AAA2714

The Switch LEDs and the CPU LEDs serve as a bar graph to indicate card activity. The Switch bar graph increases as the switch fabric utilization increases. The CPU bar graph increases when the CPU is actively performing tasks, such as learning media access control (MAC) addresses, updating routing tables, or interacting with the device management station.

"8692omSF module LEDs" (page 70) describes the 8692omSF module LEDs.

**8692omSF module LEDs**

Label	Color/State	Meaning								
Mz	Green	The mezzanine card completed software initialization and is operating normally.								
	Off	The mezzanine card is not installed or did not initialize properly.								
Link	Green/Steady	The management port is connected and the link is good.								
	Off	There is no link to the management port.								
100	Green/Steady	The management port is operating at 100 Mb/s.								
	Off	The management port is operating at 10 Mb/s.								
Switch Utilization (8 LEDs)	Green	<p>The number of lit LEDs indicates the utilization level (full-duplex operation) of the switch fabric as follows:</p> <p>1 LED = 4.0 Gb/s - &lt; 34 Gb/s</p> <p>2 LEDs = 34 Gb/s - &lt; 68 Gb/s</p> <p>3 LEDs = 68 Gb/s - &lt; 102 Gb/s</p> <p>4 LEDs = 102 Gb/s - &lt; 136 Gb/s</p> <p>5 LEDs = 136 Gb/s - &lt; 170 Gb/s</p> <p>6 LEDs = 170 Gb/s - &lt; 204 Gb/s</p> <p>7 LEDs = 204 Gb/s - &lt; 238 Gb/s</p> <p>8 LEDs = 238 Gb/s - &lt; 256 Gb/s</p>								
CPU Utilization (8 LEDs)	Green	<p>The number of lit LEDs indicates the level of CPU activity (full-duplex operation) as follows:</p> <table> <tr> <td>1 LED = 12%</td> <td>5 LEDs = 60%</td> </tr> <tr> <td>2 LEDs = 24%</td> <td>6 LEDs = 72%</td> </tr> <tr> <td>3 LEDs = 36%</td> <td>7 LEDs = 84%</td> </tr> <tr> <td>4 LEDs = 48%</td> <td>8 LEDs = 100%</td> </tr> </table>	1 LED = 12%	5 LEDs = 60%	2 LEDs = 24%	6 LEDs = 72%	3 LEDs = 36%	7 LEDs = 84%	4 LEDs = 48%	8 LEDs = 100%
1 LED = 12%	5 LEDs = 60%									
2 LEDs = 24%	6 LEDs = 72%									
3 LEDs = 36%	7 LEDs = 84%									
4 LEDs = 48%	8 LEDs = 100%									
Power Supply 1, 2, 3	Green/Steady	The specified power supply is operating normally.								
	Amber/Steady	The specified power supply has a fault.								
	Off	A power supply is not present in the specified bay, or the power supply in the specified bay is not turned on.								

Label	Color/State	Meaning
Fan 1, 2	Green/Steady	The specified fan is operating normally.
	Amber/Steady	The specified fan has failed.
Temp	Green/Steady	The temperature is normal for switch operation.
	Amber/Steady	The temperature of the switch has exceeded the maximum operating temperature.
Master	Green/Steady	The CPU subsystem on the module is performing diagnostics.
	Green/Blinking	This module is providing active CPU functions for the switch and is the master CPU module.
	Amber/Steady	The CPU subsystem is in a fault state.
	Off	The CPU subsystem on the module is up and is in standby mode.
Online	Green/Steady	The switch fabric portion of the module is online and is load-sharing.
	Amber/Steady	The switch fabric portion of the module failed diagnostics.
	Off	The switch fabric portion of the module is offline.

### Ethernet management port

The Ethernet management port on the 8692omSF module is an MDI 10/100BaseT port that allows out-of-band management of the switch using a Web browser or Device Manager. You can also establish a Telnet or SSH (Secure Shell) session to access the CLI. Use this port to connect the switch to a network management station. The Ethernet management port has its own IP address but does not switch traffic to other ports in the chassis.

Note that you use this port only as a management port. This port provides out-of-band management for the 8692omSF module.

### DCE/DTE switch

The DCE/DTE switch changes the pin assignments on the Console port and allows you to designate the connector as either DTE or DCE. For information about pin assignments for the Console port, see "[Console serial port](#)" (page 132).

### Serial ports

The 8692omSF module provides two serial ports for attaching modem and console devices. The Console port provides terminal access to the 8692omSF module to use the CLI. The Modem port allows you to connect a standard modem for out-of-band, dial-up management. For information about pin assignments for these ports, see "[Console serial port](#)" (page 132) and "[Modem serial port](#)" (page 133).

### Reset button

Use the recessed Reset button on the module to perform a hard reset or reboot of the system. To press the Reset button, insert a small object (for example, a paper clip) into the Reset button hole.

### PC Card slot

The PC Card slot in the 8692omSF module accepts the PC Cards listed in "[Metro Ethernet Routing Switch 8600 PC Cards](#)" (page 72). This memory card provides a convenient way to store switch configurations and boot images. Using a memory card, you can quickly transfer configurations and images between switches or store multiple configurations for a single switch.

#### Metro Ethernet Routing Switch 8600 PC Cards

Part number	Card Type
DS1411003	PC Card 8M 3.3 V
DS1411014	PC Card 16M 3.3V
DS1411021	PC Card 64M 3.3 V
DS1411022	PC Card 256M 3.3V



---

# Installing Metro Ethernet Routing Switch 8600 modules and connecting equipment

---

This chapter provides instructions for installing and connecting Metro Ethernet Routing Switch 8600 modules in an Ethernet Routing Switch 8000 Series chassis to create a Metro Ethernet Routing Switch 8600.

## Navigation

- ["Removing a filler panel" \(page 73\)](#)
- ["Installing a filler panel" \(page 75\)](#)
- ["Installing and replacing a module" \(page 75\)](#)
- ["Connecting a PC or terminal to the switch" \(page 86\)](#)
- ["Connecting a modem to the switch" \(page 86\)](#)
- ["Connecting a network management station to the switch" \(page 88\)](#)
- ["Connecting communications cables to Metro Ethernet Routing Switch 8600 modules" \(page 89\)](#)
- ["Managing cables for the Ethernet Routing Switch 8000 Series chassis" \(page 93\)](#)
- ["Initializing the 8672ATME, 8672ATMM, and 8683POSM modules" \(page 96\)](#)

## Removing a filler panel

Remove a filler panel so that you can install a new module.

Nortel ships the 8000 Series chassis with a filler panel covering each empty module slot.

On a 8003, 8006, or 8010 chassis, the filler panel covers an empty module slot. On the 8010co chassis, the filler panel resembles a module and is installed in the empty module slot.

## Procedure steps

Step	Action
1	Using a Phillips screwdriver, loosen the two captive screws that fasten the filler panel to the chassis ("Removing a filler panel: 8003, 8006, and 8010 chassis" (page 74) or "Removing a filler panel: 8010co chassis" (page 74)).

### Removing a filler panel: 8003, 8006, and 8010 chassis

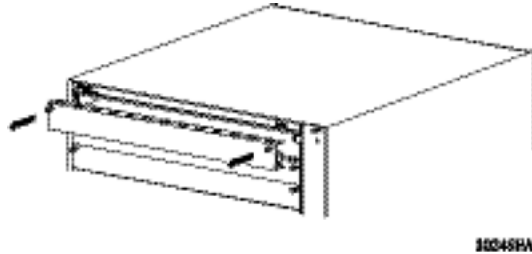

### Removing a filler panel: 8010co chassis

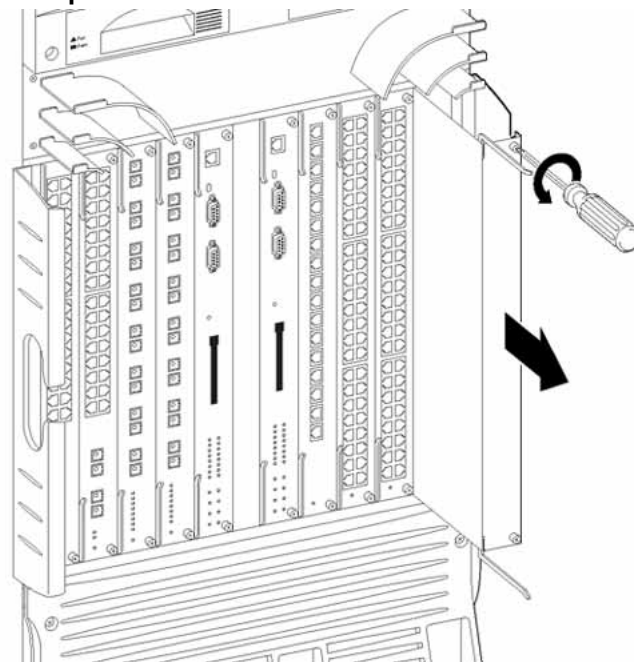

2	Pull the filler panel away from the slot.
---	---

—End—

## Installing a filler panel

If you plan to remove a module from the chassis without immediately replacing it, you must install a filler panel in the slot.

### Procedure steps

Step	Action
1	Locate the slot where you want to install the filler panel.
2	If you have an 8010co chassis, insert the filler panel into the slot. OR If you have an 8003, 8006, or 8010 chassis, place the filler panel over the slot.
3	Tighten the two screws with a Phillips screwdriver.

—End—

## Installing and replacing a module

This section contains procedures for installing and replacing a module.

You can add or replace a module with the power on or off.

### Prerequisites

- The Metro Ethernet Routing Switch 8600 modules are sensitive to static electricity. Static discharge from your clothing or other fixtures around you, even at levels that do not create a spark, can cause damage to the Metro Ethernet Routing Switch 8600 modules.



#### CAUTION

Electrostatic discharge can damage hardware. Do the following to protect your equipment from damage.

To prevent static discharge when you work with Metro Ethernet Routing Switch 8600 modules, place each module on a grounded antistatic mat until you are ready to install it. If you do not have an antistatic mat, wear a discharge leash or wrist strap to free yourself of static before you touch a module. (An antistatic wrist strap is shipped with the 8010co chassis.) You can also free yourself of static by touching the metal chassis before you handle the module.

- Handle fiber-optic equipment with the following precaution.



### WARNING

Fiber-optic equipment can emit laser or infrared light that can injure your eyes. Never look into an optical fiber or connector port. Always assume that fiber-optic cables are connected to a light source.



8769233

### Navigation

- ["Removing a module" \(page 76\)](#)
- ["Installing a module" \(page 81\)](#)

### Removing a module

Remove or replace a module in your chassis.

You can remove any Metro Ethernet Routing Switch 8600 module from an operating switch chassis without turning off the chassis power.

### Prerequisites

- Back up your configuration before you remove a 8691omSF or 8692omSF module.



### CAUTION

If the chassis has only one 8691omSF or 8692omSF module and you remove that module, the switch will not operate.

- After you remove or replace a module in your chassis, you can expect the following results:
  - If you remove an interface module from an operating switch without turning off the chassis power and replace it with the same type module, the system restores the configuration.

- To remove a module from an active system, you must disable the module before you remove it. Disabling the slot before removing the module provides a clean disconnect from all services.

The following procedure includes directions for disabling the module.

- If you remove an 8672ATME, 8672ATMM, or 8683POSM module from an operating switch without turning off the chassis power and the module you insert has the same type MDAs installed as the module that you removed, the system saves the configuration.
- If you remove an 8672ATME, 8672ATMM, or 8683POSM module from an operating switch without turning off the chassis power and the module you insert has different MDAs installed than the module that you removed, you must reconfigure the module. Nortel recommends that you save the original configuration in a file for future use.
- If you replace a module with a different type module, the system discards the configuration of the old ports and adds the new ports to either the default VLAN or a null VLAN, depending on the operating mode of the switch.
- If you save the configuration in nonvolatile random access memory (NVRAM), turn off the switch, replace a module with a different module type, and turn the system on again, the system discards the configuration of the old ports and adds new ports to either the default VLAN or an unassigned VLAN, depending on the operating mode of the switch.
- If you replace an 8691omSF or 8692omSF module, all the other modules in the chassis reset and revert to their saved configuration settings. If you did not save the configuration settings for a module, the module reverts to its factory default settings.

## Procedure steps

Step	Action
1	Connect to the Metro Ethernet Routing Switch 8600 command line interface (CLI) using the management console port.
2	To disable the slot of the module that you are removing, enter the following command. Specify the slot number for <slotnum>.  <code>conf slot &lt;slotnum&gt; state disable</code>
3	Confirm that the module is disabled.  The online LED on the front panel module is amber when the I/O module is disabled.

For a CPU module, the online LED will be off or amber when the CPU module is disabled.

- 4 Disconnect any cables attached to the ports on the module.



**CAUTION**

Do not operate the Metro Ethernet Routing Switch 8600 with an empty module slot. If you need to replace a failed module and you do not yet have a replacement module, leave the failed module installed or install a filler panel.

- 5 Using a Phillips screwdriver, loosen the two captive screws that secure the module to the chassis ("[Loosening screws on the module: 8003, 8006, and 8010 chassis](#)" (page 78) or "[Loosening screws on the module: 8010co chassis](#)" (page 79)).

**Loosening screws on the module: 8003, 8006, and 8010 chassis**

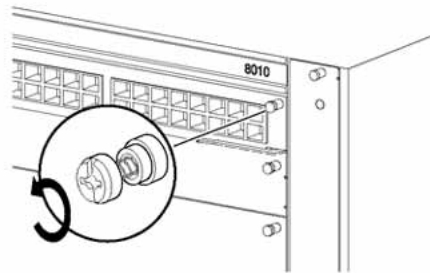

10355EA

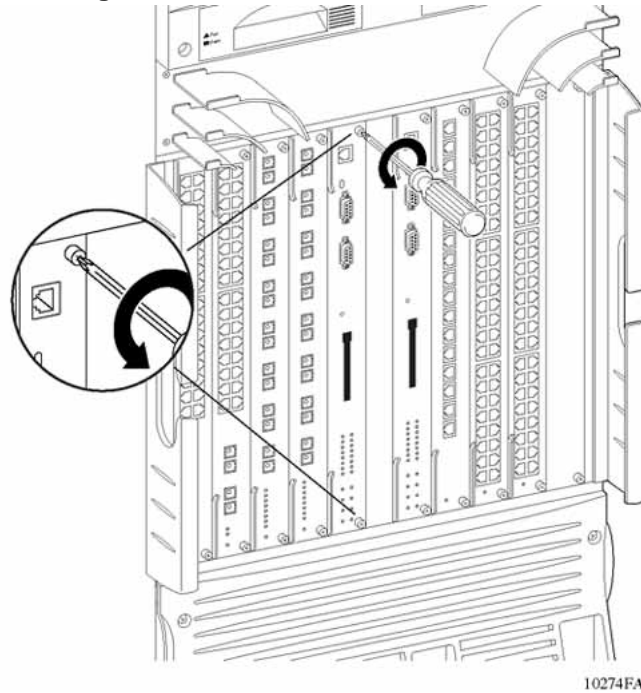
**Loosening screws on the module: 8010co chassis**

- 6 Rotate the insert/extract levers to eject the module from the chassis ("Ejecting the module from the chassis: 8003, 8006, and 8010 chassis" (page 79) or "Ejecting the module from the chassis: 8010co chassis" (page 80)).

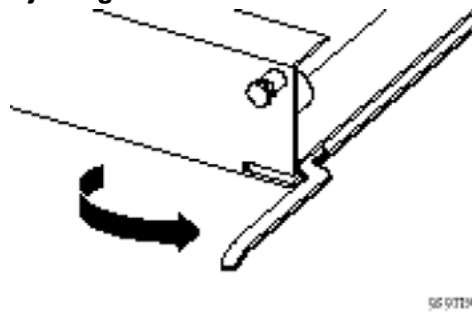
**Ejecting the module from the chassis: 8003, 8006, and 8010 chassis**

**Ejecting the module from the chassis: 8010co chassis**

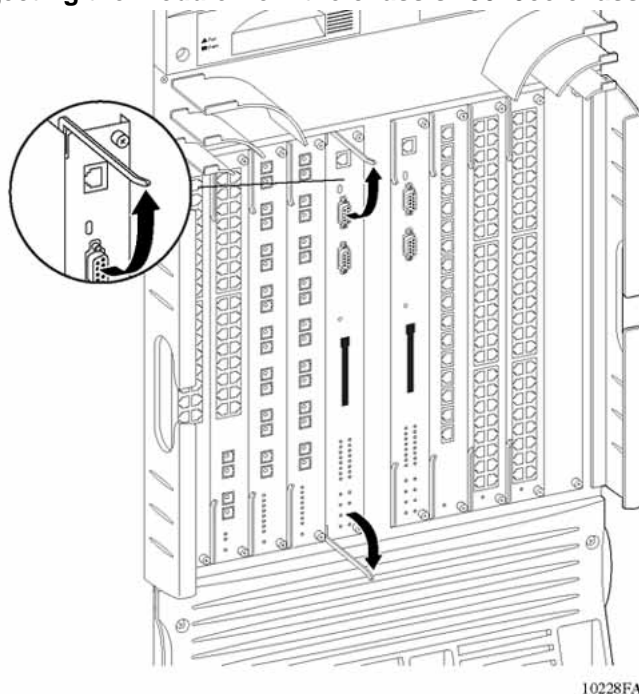

- 7 Slide the module out of the chassis ("Removing a module: 8003, 8006, and 8010 chassis" (page 80) or "Removing a module: 8010co chassis" (page 81)).

**Removing a module: 8003, 8006, and 8010 chassis**

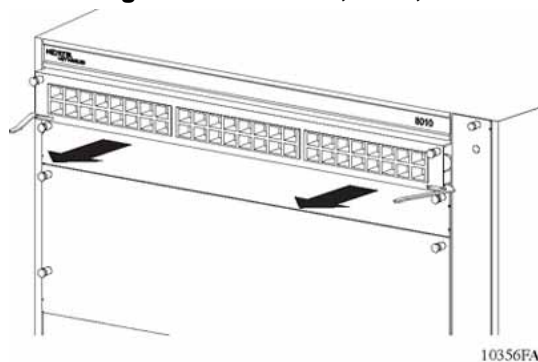

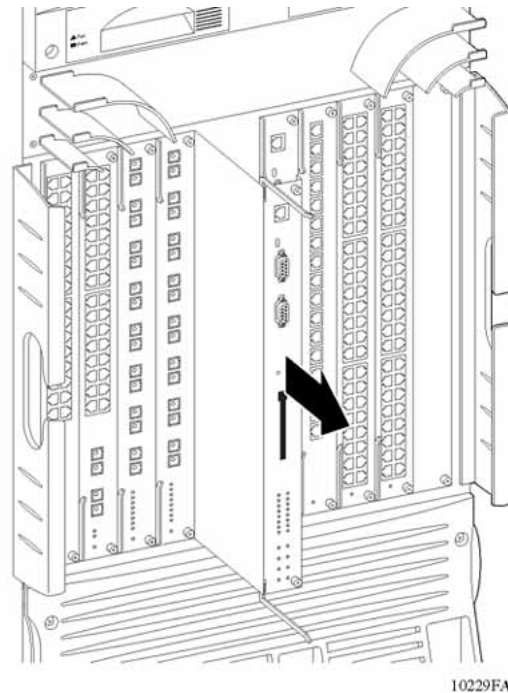

**Removing a module: 8010co chassis**

- 8 If you are installing a replacement module, go to ["Installing a module"](#) (page 81). Otherwise, install a filler panel (see ["Installing a filler panel"](#) (page 75)).

---

—End—

---

**Installing a module**

Install a Metro Ethernet Routing Switch 8600 module.

You can install a Metro Ethernet Routing Switch 8600 module with the power on or off. If you install a module in the same chassis slot where the same type of module was previously installed, the previous configuration is maintained for that module in that slot. With the 8672ATME, 8672ATMM, and 8683POSM modules, the configuration is maintained only if the same type of MDAs are used. In all other cases, a module installed in an Ethernet Routing Switch 8000 Series chassis resets to factory defaults.

**Prerequisites**

- Review the antistatic precautions on ["Installing and replacing a module"](#) (page 75).



**CAUTION**

Electrostatic discharge can damage hardware.

**Procedure steps**

Step	Action
1	Locate the slot where you want to install the module.
2	Remove the installed module or the filler panel. For instructions, see "Removing a module" (page 76) or "Removing a filler panel" (page 73).
3	Make sure that the insert/extract levers are extended away from the front of the module (see "Ejecting the module from the chassis: 8003, 8006, and 8010 chassis" (page 79) or "Ejecting the module from the chassis: 8010co chassis" (page 80)).
4	Slide the module into the slot using the slot module guides ("Installing a module: 8003, 8006, and 8010 chassis" (page 82) or "Installing a module: 8010co chassis" (page 83)).

**Installing a module: 8003, 8006, and 8010 chassis**

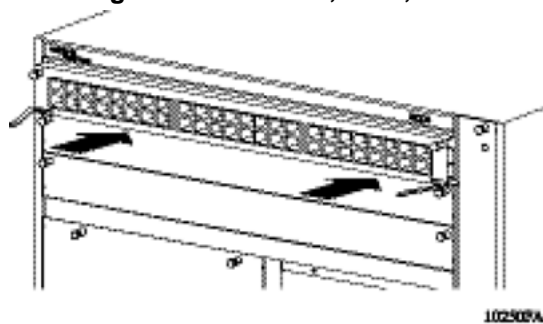

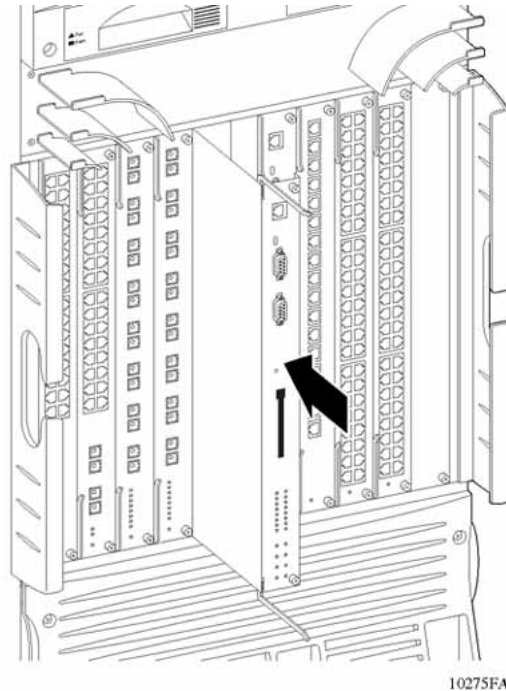
**Installing a module: 8010co chassis**

- 5 Slide the module into the chassis until its connector panel touches the chassis back panel.
- 6 Rotate the insert/extract levers to seat the module backplane connectors ("Seating the backplane connectors: 8003, 8006, and 8010 chassis" (page 83) or "Seating the backplane connectors: 8010co chassis" (page 84)).

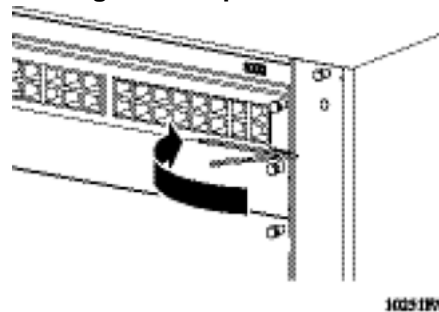
**Seating the backplane connectors: 8003, 8006, and 8010 chassis**

**Seating the backplane connectors: 8010co chassis**

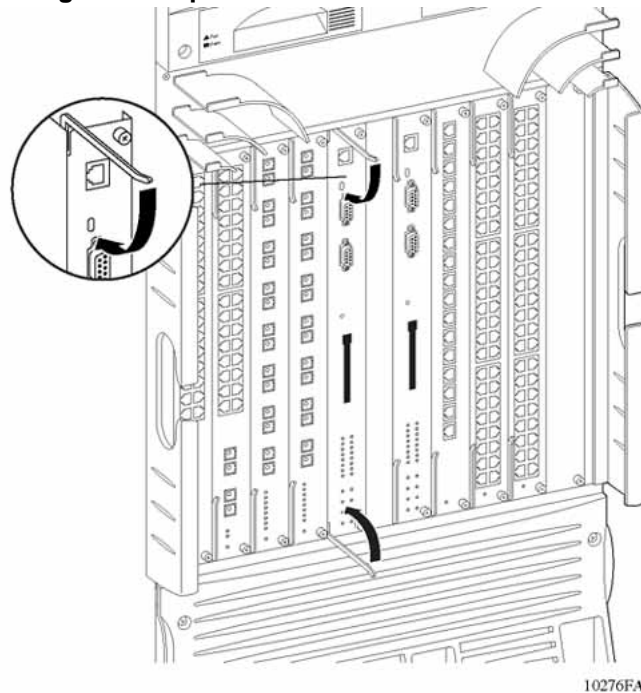

- 7 Using a Phillips screwdriver, tighten the 2 captive screws to secure the module to the chassis ("[Securing the module in the chassis: 8003, 8006, and 8010 chassis](#)" (page 85) or "[Securing the module in the chassis: 8010co chassis](#)" (page 85)).

Make sure you securely tighten all captive screws for proper module operation. This ensures a good connection between the module and the backplane and prevents apparent module failure of properly functioning modules.

If a module failure occurs, check for possible backplane connection problems as a cause. Make sure the module is correctly seated in the backplane connector and the captive screws are securely tightened. If the module still fails to operate, contact Nortel customer support for assistance.

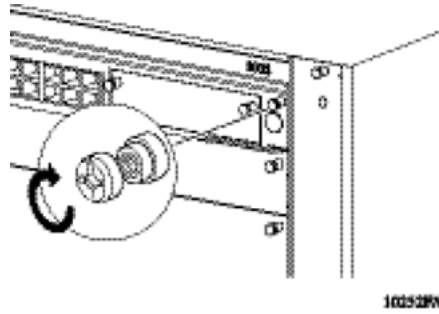
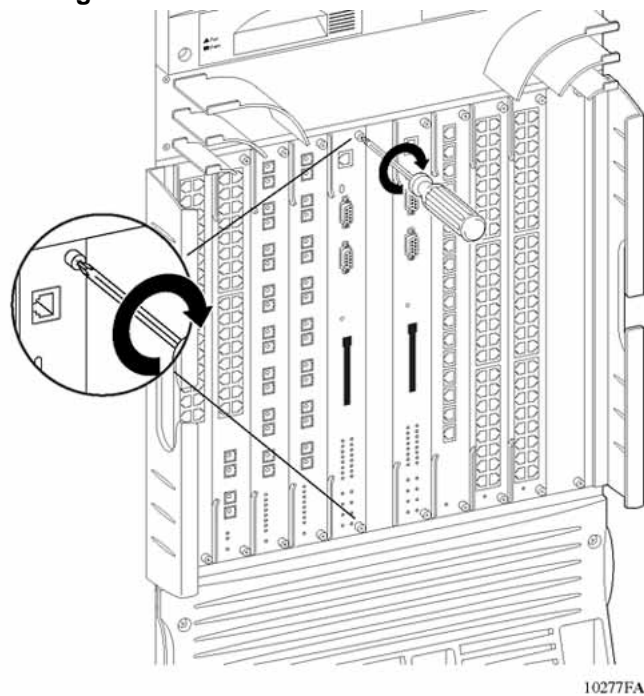
**Securing the module in the chassis: 8003, 8006, and 8010 chassis****Securing the module in the chassis: 8010co chassis**

- 8 If the slot is disabled, the new module does not automatically boot. Enable the slot by using the following command:  

```
conf slot <slotnum> state enable
```

 <slotnum> specifies the number of the slot.
- 9 Confirm that the new module boots and that the online LED is green.

---

—End—

---

## Connecting a PC or terminal to the switch

Connect a PC or terminal to the console port to use Device Manager or the command line interface (CLI) to customize your Metro Ethernet Routing Switch 8600 configuration (for example, by editing IP parameters). To establish a local CLI or Device Manager session, you must connect a PC or a VT-100 terminal to the console port on the CPU module.

### Prerequisites

- You need a serial console cable with a 9-pin receptacle connector.

### Procedure steps

Step	Action
1	Turn on and configure the terminal or a communications port on the PC using the values in " <a href="#">Procedure job aid: PC and terminal settings</a> " (page 86).  See the PC or terminal user manual for instructions.
2	Insert the 9-pin receptacle end of the console cable into the console connector on the CPU module.
3	Attach the 9-pin plug end of the cable to the serial communications port on the back of the PC or terminal.

—End—

### Procedure job aid: PC and terminal settings

Use the following table to configure the communications port on the PC or terminal.

#### PC and terminal settings

Parameter	Value
Baud rate	9600
Data bits	8
Stop bits	1
Parity	None

## Connecting a modem to the switch

Connect a modem to the Metro Ethernet Routing Switch 8600 to enable remote access to the switch.

If you need remote dial-in access to the CLI, you can connect a modem to the CPU module using a serial cable.

### Prerequisites

- The Metro Ethernet Routing Switch 8600 supports the AT or Hayes compatible modem.
- You need a DTE-to-DCE cable (straight or transmit cable).

Because the modem port expects to receive Data Set Ready (DSR) and Clear To Send (CTS) signals before transmitting, these control lines are required in the cables.

### Procedure steps

Step	Action
1	Turn on and configure the modem, using the parameters in "Procedure job aid: Modem settings" (page 87). See the modem documentation for instructions.
2	Insert the 9-pin receptacle end of the serial cable into the modem connector on the CPU module.
3	Insert the 25-pin plug connector at the other end of the serial cable into the RS-232 data communications port of the modem.
—End—	

### Procedure job aid: Modem settings

Use the following table to configure the modem.

#### Modem settings

Setting	Value
Clear to send (CTS) signal	On
Data terminal ready (DTR) signal	The modem only connects if the DTR signal is present. If the DTR signal is not present, the modem disconnects.
Data carrier detect (DCD) or received line signal detection (RLSD)	On while the carrier is present. The switch uses DCD to detect modem connect and disconnect.
Data set ready (DSR) signal	On
Ready to send (RTS) signal	Ignored

Setting	Value
Synchronous/asynchronous mode	Asynchronous
Auto answer	Answer on two rings when DTR is active.
Local character echo	Off
Supervisory functions	Off
Baud rate	9600
Data bits	8
Stop bits	1
Parity	None

## Connecting a network management station to the switch

Connect a network management station to the management port for out-of-band management of the switch.

The management port on the CPU modules is a 10/100 Mb/s Ethernet port implemented on an RJ-45 connector wired as an MDI connection. You can use this port to connect the switch to a network management station for out-of-band management of the switch using a Web browser or Device Manager.

The port has its own IP address but does not switch traffic to other ports in the chassis.

### Prerequisites

- To connect ports that will operate at 100 Mb/s, use only Category 5 UTP cable. For 10 Mb/s connections, you can use Category 3, 4, or 5 copper unshielded twisted pair (UTP) cable.

### Procedure steps

Step	Action
1	Insert the UTP cable into the RJ-45 receptacle connector on the CPU module.

—End—



## Connecting communications cables to Metro Ethernet Routing Switch 8600 modules

The following table lists the connectors and cables that you need to attach to the Metro Ethernet Routing Switch 8600 modules. The cable requirements for the Metro Ethernet Routing Switch 8600 modules are also provided. If you do not have the proper cables, contact your network administrator.

### Connectors and cables for Metro Ethernet Routing Switch 8600 modules

Module	Port	Connector	Recommended cable type	Minimum cable length	Maximum cable length
ESM8668	1000 Mb/s Ethernet port	Duplex SFP fiber-optic connector or RJ-45 copper connector	See Note 2	None	See Note 2
8608GBE or 8608GBM	1000 Mb/s Ethernet port	Duplex SC fiber-optic connector or RJ-45 copper connector	See Note 2	None	See Note 2
8608GTE or 8608GTM	1000BaseT Ethernet ports	RJ-45	EIA Category 5 or better UTP/STP straight-through cable. Cables must use all four pairs.	7 ft (2.1 m)	328 ft (100 m)
8608SXE	1000Base-SX Ethernet ports	Duplex SC	62.5 $\mu$ m multimode fiber-optic cable	None	722 ft (220 m) @ 160 MHz/km bandwidth
			50 $\mu$ m multimode fiber-optic cable		902 ft (275 m) @ 200 MHz/km bandwidth
					1640 ft (500 m) @ 400 MHz/km bandwidth
					1804 ft

Module	Port	Connector	Recommended cable type	Minimum cable length	Maximum cable length
					(550 m) @ 400 MHz/km bandwidth
8616GTE	1000BaseT Ethernet ports	RJ-45	EIA Category 5 or better UTP/STP straight-through cable. Cables must use all four pairs.	7 ft (2.1 m)	328 ft (100 m)
8616SXE	1000Base-SX Ethernet ports	MT-RJ	62.5 $\mu$ m multimode fiber-optic cable	None	722 ft (220 m) @ 160 MHz/km bandwidth  902 ft (275 m) @ 200 MHz/km bandwidth
			50 $\mu$ m multimode fiber-optic cable	None	1640 ft (500 m) @ 400 MHz/km bandwidth
				None	1804 ft (550 m) @ 400 MHz/km bandwidth
8624FXE	100Base-FX Ethernet ports	MT-RJ	62.5 $\mu$ m multimode fiber-optic cable	None	6562 ft (2 km) for 62.5 $\mu$ m MMF full-duplex links or 4264 ft (1.3km) for 50 $\mu$ m MMF full-duplex links.
8630GBR	1000 Mb/s Ethernet ports	SFP	See Note 3	None	See Note 3

Module	Port	Connector	Recommended cable type	Minimum cable length	Maximum cable length
8632TXE or 8632TXM	1000 Mb/s Ethernet port	Duplex SC	See Note 4	None	See Note 4
	10/100 Mb/s Ethernet ports (see Note 1)	RJ-45 wired as MDI-X	EIA Category 3, 4, or 5 UTP for 10 Mb/s operation; EIA Category 5 UTP required for 100 Mb/s operation	None	328 ft (100 m)
8648GTR	10/100/1000 Mb/s Ethernet ports	RJ-45	EIA Category 5 UTP	See Note 5	328 ft (100 m)
8648TXE or 8648TXM	10/100 Mb/s Ethernet ports (see Note 1)	RJ-45 wired as MDI-X	EIA Category 3, 4, or 5 UTP for 10 Mb/s operation; EIA Category 5 UTP required for 100 Mb/s operation	None	328 ft (100 m)
8672ATME OC-3 or 8672 TMMOC-3	OC-3	MT-RJ	9/125 $\mu$ m single-mode fiber-optic cable	None	9.3 mi (15 km)
	OC-3	MT-RJ	62.5/125 $\mu$ m multimode fiber-optic cable	None	1.24 mi (2 km)
8672ATME OC-12 or 867 2ATMMOC-12	OC-12	Duplex SC	9/125- $\mu$ m single-mode fiber-optic cable	None	9.3 mi (15 km)
	OC-12	Duplex SC	62.5/125 $\mu$ m multimode fiber-optic cable	None	1640 ft (500 m)
8672ATME DS-3 or 8672 ATMMDS-3	DS-3	BNC	75 ohm coaxial cable	None	450 ft (137 m)
8681XLR	10GBase-LR port	Duplex SC	9/125 $\mu$ m single-mode fiber-optic cable	None	10 km
8681XLW	10GBase-LW port	Duplex SC	9/125 $\mu$ m single-mode fiber-optic cable	None	10 km

Module	Port	Connector	Recommended cable type	Minimum cable length	Maximum cable length
8683POSM OC-3	OC-3	MT-RJ	9/125 $\mu\text{m}$ single-mode fiber-optic cable	None	9.3 mi (15 km)
	OC-3	MT-RJ	62.5/125 $\mu\text{m}$ multimode fiber-optic cable	None	1.24 mi (2 km)
8683POSM OC-12	OC-12	Duplex SC	9/125- $\mu\text{m}$ single-mode fiber-optic cable	None	9.3 mi (15 km)
	OC-12	Duplex SC	62.5/125 $\mu\text{m}$ multimode fiber-optic cable	None	1640 ft (500 m)
8683XLR	10GBase-LR port	Duplex LC	See Note 5	None	See Note 5
8683XZR	10GBaseR port	Duplex LC	See Note 5	None	See Note 5
8691omSF	Ethernet Management port	RJ-45	EIA Category 3, 4, or 5 UTP for 10 Mb/s operation; EIA Category 5 UTP required for 100 Mb/s operation	None	328 ft (100 m)
	Serial ports	DB-9	RS-232		
8692omSF	Ethernet Management port	RJ-45	EIA Category 3, 4, or 5 UTP for 10 Mb/s operation; EIA Category 5 UTP required for 100 Mb/s operation	None	328 ft (100 m)
	Serial ports	DB-9	RS-232		

Note 1: Ports on the 8632TXE, 8632TXM, 8648TXE, and 8648TXM modules are wired as MDI-X. Use straight-through cables to connect these ports to MDI connections such as workstations or servers. Use crossover cables to connect these ports to other MDI-X connections such as hubs or other switches.

Note 2: Depends on installed GBIC model; for specifications, see *Nortel Installation — SFP, XFP, and GBIC Hardware Components* (NN46225-301).

Note 3: Depends on installed SFP model; for specifications, see *Nortel Installation — SFP, XFP, and GBIC Hardware Components* (NN46225-301).

Module	Port	Connector	Recommended cable type	Minimum cable length	Maximum cable length
Note 4: Depends on installed Gigabit Ethernet transceiver model; for specifications, see <i>Nortel Installation — SFP, XFP, and GBIC Hardware Components</i> (NN46225-301).					
Note 5: Depends on installed XFP model; for specifications, see <i>Nortel Installation — SFP, XFP, and GBIC Hardware Components</i> (NN46225-301).					

## Managing cables for the Ethernet Routing Switch 8000 Series chassis

Manage the cables for the Ethernet Routing Switch 8000 Series chassis to keep them fastened and out of the way.

The Ethernet Routing Switch 8000 Series chassis ship with cable management brackets. The cable management brackets keep groups of cable clusters fastened and out of the way, but accessible for maintenance.

To facilitate card installation and removal, bundle the cables for each slot. Connect, label, and bundle the cables for each module together, then use Velcro straps or sheet fiber wrapped around the cables to organize them along the entire cable path before you connect cables to another module. Secure the Velcro straps or sheet fiber to brackets with lacing cord or tie wrap.

### Procedure steps

Step	Action
1	Connect the appropriate cable to the module.
2	Route the cable up to the appropriate cable management bracket and channel (" <a href="#">Managing cables: 8010co chassis</a> " (page 94) and " <a href="#">Managing cables: 8010, 8006, 8003 chassis</a> " (page 95)).

**Managing cables: 8010co chassis**

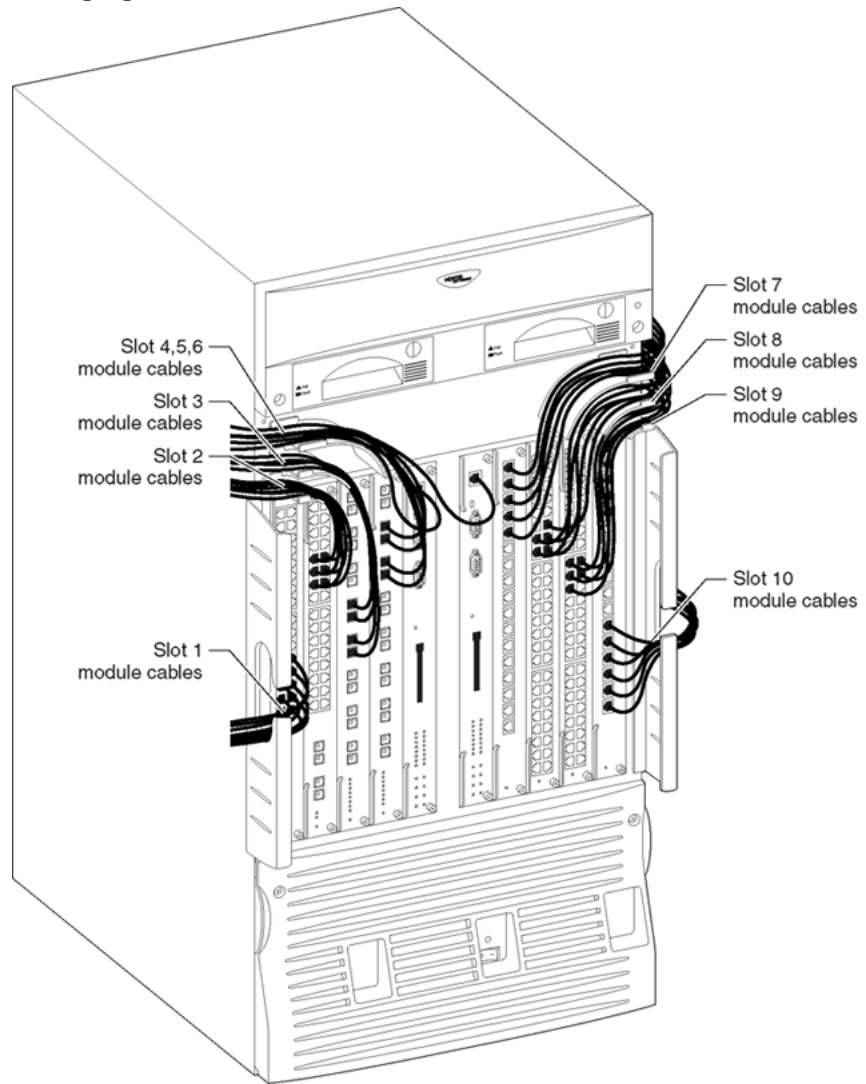

10520FA

**Managing cables: 8010, 8006, 8003 chassis**

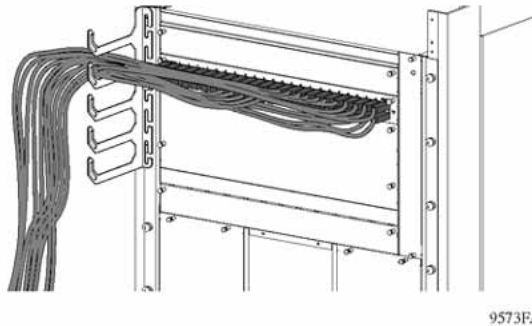

- 3 Route the cable to the termination panel, loosely fastening the cable with Velcro straps or sheet fiber along the path.
- 4 Fasten the connector onto the termination panel end of the cable. Use the instructions supplied with the connector. If you are using cables manufactured by Nortel, the connectors are already fastened to predetermined lengths of cable.
- 5 Label the unconnected end of the cable with the node identifier (from site records) and the shelf, cage, slot, and port number.
- 6 When all the transmitting cables from the same module are connected to the termination panel, use Velcro straps or sheet fiber wrapped around the cables to manage them.
- 7 Using scissors, cut a section of the sheet fiber that is wide enough to wrap around the cables.
- 8 Using scissors, round the corners of the sheet fiber section.
- 9 Loosely wrap the sheet fiber and secure it using lacing cord or tie wraps ("Wrapping cables with sheet fiber and securing with lacing cord" (page 96)).

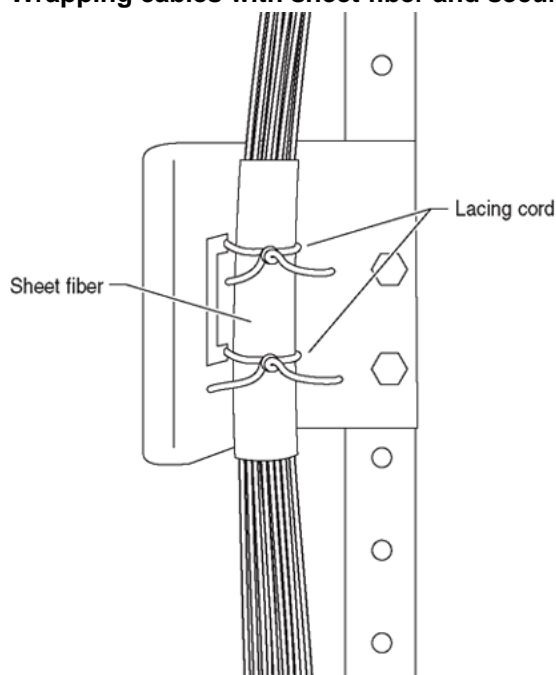
**Wrapping cables with sheet fiber and securing with lacing cord**

10826EA

- 10** Secure the Velcro straps or sheet fiber to brackets with lacing cord or tie wraps.

—End—

**Initializing the 8672ATME, 8672ATMM, and 8683POSM modules**

If you have installed a 8672ATME, 8672ATMM, or 8683POSM module with at least one MDA into an Ethernet Routing Switch 8000 Series chassis, the CPU module retrieves the image file to download to these modules. Ensure that the installed CPU module has a PC Card inserted and that the PC Card contains the correct image for the installed module. For a list of image filenames, see ["Image filenames for 8672ATME/8672ATMM/8683POSM" \(page 96\)](#). In this table, xxxx denotes the release number. For the current file names, see the release notes that accompany your version of the software.

**Image filenames for 8672ATME/8672ATMM/8683POSM**

module	Image filename
8672ATME	p80txxxx.dld
8672ATMM	p80txxxx.dld
8683POSM	p80pxxxx.dld



For more information about the PC Card slot and the CPU module, see "[PC Card slot](#)" (page 67) (8691omSF) or "[PC Card slot](#)" (page 72) (8692omSF).

The following sections describe the initialization process for the 8672ATME, 8672ATMM, and 8683POSM modules.

### Initializing the 8672ATME and 8672ATMM modules

The CPU module retrieves the image file to download to the 8672ATME or 8672ATMM module. First, the CPU module searches the host flash memory for the file, then the PC Card. The CPU module downloads the image file to the 8672ATME, or 8672ATMM and identifies which MDAs are installed. The screen displays a message similar to the following:

```
Using image = /slot/p80t3600.dld for ATM card download.
ATM card: Slot 4 MDA [OC-12c MM] [Quad OC-3c MM] Ver=2.2
```

If the image file is not found in either the flash memory or the PC Card, the system stops and the screen displays an error message such as:

```
ERROR Task=rcStart Couldn't find an ATM download image!
Aborting card initialization in Slot=4
```

or:

```
ERROR Task=rcStart portPresent:port=X/X, invalid port Type
```

The 8672ATME or 8672ATMM module requests a redownload from the switch fabric module, and the screen displays the following message:

```
Redownload requested by ATM card in slot <number>.
```

If the image download is unsuccessful, the screen displays the following message:

```
ATM card in slot <number> not ready.
```

If there are three unsuccessful attempts to download, the screen displays the message shown in "[Unsuccessful download screen output](#)" (page 98).

**Unsuccessful download screen output**

```

Copyright (c) 2005 Nortel, Inc.
CPU Slot 5:    PPC 745 Map B
Version:      4.0.0.OOE/0
Creation Time: Mar 19 2005, 17:51:07
Hardware Time: APR 03 2005, 13:58:01 UTC
Memory Size:  0x04000000
Start Type:   warm
SMART ATA Flash Card TIDALWV SH007
/flash/ - Volume is OK
can't open "/pcmcia/pcmbboot.cfg" 0x388002
S_dosFsLib_FILE_NOT_FOUND
/flash/ - Volume is OK
Loaded boot configuration from file/flash/boot.cfg
Loading release_builds/himalaya1.0/b86/p80a4.000b0.img with tftp from
198.202.188.174...5779129 to 20307814 (20307814)
Starting at 0x10000...
SMART ATA Flash Card TIDALWV SH007
/flash/ - Volume is OK
Passport 8600 System Software Release REL4.0.0.0_B0
Copyright (c) 1996-2005 Nortel, Inc.
/pcmcia/ - Volume is OK
CPU5[03/03/04 14:58:20] SW INFO System boot
CPU5[03/03/04 14:58:20] SW INFO Passport System Software Release
REL3.7.0.0_B086
CPU5[03/03/04 14:58:21] HW INFO Card inserted: Slot=5 Type=8690SF
CPU5[03/03/04 14:58:21] HW INFO Card inserted: Slot=1 Type=8648TX
CPU5[03/03/04 14:58:21] HW INFO Card inserted: Slot=4 Type=8672ATME
CPU5[03/03/04 14:58:21] HW INFO Card inserted: Slot=8 Type=8662SAM
CPU5[03/03/04 14:58:21] HW INFO Card inserted: Slot=10 Type=8661SAM
CPU5[03/03/04 14:58:21] HW INFO Initializing 8690SF in slot #5...
CPU5[03/03/04 14:58:21] HW INFO Initializing 8648TX in slot #1...
CPU5[03/03/04 14:58:21] HW INFO Initializing 8672ATME in slot #4 ...
CPU5[03/03/04 14:58:24] ATM ERROR Couldn't find an ATM download image!
(File name: /flash/p80t4000.dld or /pcmcia/p80t4000.dld)
Slot 4 ATM card is put offline!
CPU5[03/03/04 14:58:41] HW INFO Initialization of card failed for Slot 4 !
CPU5[03/03/04 14:58:41] HW INFO Initializing 8662SAM in slot #8 ...
CPU5[03/03/04 14:58:43] HW INFO Initializing 8661SAM in slot #10 ...
CPU5[05/03/04 14:58:50] SW INFO Loading configuration from /flash/config.cfg
CPU5[03/03/04 14:58:50] SW INFO The system is ready

```

After the image is loaded onto the 8672ATME or 8672ATMM module, the image performs a series of self-diagnostic tests. If the module fails the diagnostics, the screen displays the following message:

```
Fatal bring up error on ATM card in slot <number>.
```

If you see this message, contact a customer service representative.

When the image is loaded successfully onto the 8672ATME or 8672ATMM module, the screen displays the following message:

```
ATM card in slot <number> is online.
```

If you accidentally delete the image file, reset the CPU module and download the file again. For information about how to reset the CPU module, see *Nortel Metro Ethernet Routing Switch 8600 Installation — Chassis Installation and Maintenance* (NN46220-305).

If you have one MDA installed, you can proceed to configure the 8672ATME or 8672ATMM module as described in *Using the 8672ATME and 8672ATMM Modules* (209195-G).

You must save your configuration using either the CLI or Device Manager to preserve the configuration changes you made to the 8672ATME or 8672ATMM module across reboots.

### Initializing the 8683POSM module

The CPU module retrieves the image file to download to the 8683POSM module. First, the CPU module searches the host flash memory for the file, then the PC Card. The CPU module downloads the image file to the 8683POSM module and identifies which MDAs are installed. The screen displays a message similar to the following:

```
Downloading POS image to slot <number> .....Done (file
name and image size.)
```

If the CPU module does not find the image file in either the flash memory or the PC Card, the screen displays this message:

```
POS image file name not found either in FLASH or PCMCIA.
```

If the download is unsuccessful, the screen displays the following message:

```
Card is off line.
```

The 8683POSM module requests a redownload from the CPU module; the screen displays this message:

```
Redownload requested by POS card in slot <number>.
```

The 8683POSM module attempts a redownload three times. If the download is still unsuccessful, the 8683POSM module goes offline and the screen displays this message:

```
Redownload of POS card in slot <number> failed maximum 3
times; POS card is offline.
```

When the 8683POSM module boots, the redownload count is reset to 0. After the image is loaded onto the 8683POSM module, the image performs a series of self-diagnostic tests. If the module fails the diagnostics, the screen displays the following message:

```
Port <number> for POS card in slot <number> failed
diagnostics.
```

If you see this message, contact a customer service representative.

When the image is loaded successfully onto the 8683POSM module, the screen displays the following message:

```
POS card in slot <number> is online.
```

If you accidentally delete the image file, reset the CPU module and download the file again. For information about how to reset the CPU module, see *Nortel Metro Ethernet Routing Switch 8600 Installation — Chassis Installation and Maintenance* (NN46220-305).

If you have one MDA installed, you can proceed to configure the 8683POSM module as described in *Using the 8683POSM Module* (209564-C).

You must save your configuration using either the CLI or Device Manager to preserve the configuration changes you made to the 8683POSM module across reboots.

---

# Appendix A

## Metro Ethernet Routing Switch 8600 module technical specifications

---

This appendix provides technical specifications for the Metro Ethernet Routing Switch 8600 modules.

### Navigation

- ["General specifications" \(page 102\)](#)
- ["8608GBE and 8608GBM modules" \(page 105\)](#)
- ["8608GTE and 8608GTM modules" \(page 107\)](#)
- ["8608SXE module" \(page 109\)](#)
- ["8616GTE module" \(page 110\)](#)
- ["8616SXE module" \(page 111\)](#)
- ["8624FXE module" \(page 113\)](#)
- ["8630GBR module" \(page 114\)](#)
- ["8632TXE and 8632TXM modules" \(page 115\)](#)
- ["8648GTR module" \(page 116\)](#)
- ["8648TXE and 8648TXM modules" \(page 117\)](#)
- ["ESM 8668 Metro Ethernet Services Module" \(page 119\)](#)
- ["8672ATME and 8672ATMM modules" \(page 119\)](#)
- ["8681XLR module" \(page 121\)](#)
- ["8681XLW module" \(page 123\)](#)
- ["8683POSM module" \(page 124\)](#)
- ["8683XLR module" \(page 126\)](#)
- ["8683XZR module" \(page 127\)](#)
- ["8691omSF module" \(page 128\)](#)

- "8692omSF module" (page 131)

## General specifications

### Standards supported

IEEE Std 802.3, 1998 Clause 4 Media Access Control CSMA/CD

IEEE Std 802.3, 1998 Clause 14 10Base T New

IEEE Std 802.3, 1998 Clause 21 100Base T

ANSI/IEEE Std 802.3, 1998 Media Access Control (MAC) Bridges

IEEE 802.1Q Virtual Bridged Local Area Networks

IEEE Std 802.3, 1998 Clause 34-42

IEEE 802.3, 1998 Clause 31 (MAC Control)

IEEE Std 802.3ab

IEEE Std 802.3ae

### Data rate and encoding

10 Mb/s Manchester encoding

100 Mb/s 4B/5B encoding

1000 Mb/s 8B/10B encoding

10 Gb/s 64/66B encoding

### Environmental specifications

Operating temperature:  
0°C to 40°C (32°F to 104°F)

Storage temperature:  
-25°C to 70°C (-13°F to 158°F)

Operating humidity:  
85% maximum relative humidity, noncondensing

Storage humidity:  
95% maximum relative humidity, noncondensing

Operating altitude:

3 000 m (10 000 ft) maximum

Free fall/drop:  
ISO 4180-s, NISTA 1A

Vibration:  
IEC 68-2-6/34

Shock/bump:  
IEC 68-2-27/29

### **Performance specifications (64-byte packets)**

Aggregate throughput:  
maximum 384 Mpps

Routing and switching  
10 Mb/s: 14 880 pps maximum

Forwarding rates:  
100 Mb/s: 148 810 pps maximum

1000 Mb/s: 1 488 100 pps maximum

Latency:  
Minimum 10 microseconds

### **Address database**

Address table size:

E modules:  
32 000 table entries per system

M modules:  
128 000 table entries per system (when configured for M mode)  
Note that some entries are reserved for system use.

Addressing:  
48-bit MAC address

32-bit IP address

Frame length:  
64 to 1518 bytes (IEEE 802.1Q Untagged)

64 to 1522 bytes (IEEE 802.1Q Tagged)

64 to 1950 bytes (8632TXE, 8632TXM, 8648TXE, 8648TXM, 8616SXE, and 8616GTE modules with Release 3.3 or greater)

64 to 9600 bytes (8608GBE, 8608GBM, 8608GTE, 8608GTM, 8681XLW, 8681XLR modules only with Release 3.3 or greater))

### **Electromagnetic emissions**

Meets requirements of:

US:

FCC CFR47 Part 15, Subpart B, Class A

Canada:

ICES-003, Issue-2, Class A

Australia/New Zealand:

AS/NZS 3548:1995, Class A

Japan:

VCCI-V3/97.04, Class A

Taiwan:

CNS 13438, Class A

Europe:

EN 55022-1998 Class A; EN 61000-3-2/A14, EN 61000-3-3

Global:

CISPR 22-1997 Class A

CE Mark

Electromagnetic susceptibility:

EN55024:1998/CISPR 24:1997

### **Safety agency approvals**

US:

UL60950

Canada:

CSA 22.2 No. 60950

Australia/New Zealand:

AS/NZS 3260

Mexico:

NOM-019-SCFI-1998

The Gigabit Ethernet transceivers installed in the 8608GBE and 8608GBM modules must also meet the standards listed above. In addition, the Gigabit Ethernet transceivers are certified to FDA requirement 21 CFR, Chapter 1, Subchapter J and the international requirements of IEC 60825 for Class 1 Laser.



## 8608GBE and 8608GBM modules

### Physical specifications

Height:  
1.5 in. (3.8 cm)

Width:  
15.4 in. (39.1 cm)

Depth:  
18.5 in. (47.0 cm)

Weight:  
8.0 lb (3.6 kg)

### Electrical specifications

Input power:  
65 W maximum

Thermal rating:  
224 Btu/hr maximum

### MTBF rating

197 096 hr

### Connector type

SC (fiber) or RJ-45 (copper)

## GBICs

### Physical specifications

Height: 12 mm

Width: 30 mm

Depth: 65 mm

Weight: Varies with GBIC type

**Connector type** SC (fiber) or RJ-45 (copper)

The distances listed in "[Gigabit Ethernet minimum distance ranges](#)" (page 106) represent the minimum and maximum distances attainable on high quality fiber. You may be able to run Gigabit Ethernet significantly farther assuming that the loss budget is not exceeded, and dispersion is well controlled. Nortel recommends a fiber loss analysis for each run of cable to determine actual achievable distances (see "[Gigabit Ethernet flux budget and loss characteristics](#)" (page 107)).

**Gigabit Ethernet minimum distance ranges**

<b>Transceiver/ Fiber type (see Note 1)</b>	<b>Diameter (microns)</b>	<b>Modal Band- width (MHz/ km)</b>	<b>Advertised Range (meters)</b>	<b>Average Optical Transmit Power (dBm)</b>	<b>Average Minimum Receiver Sensi- tivity (dBm)</b>	<b>Optical Wave- length (nm)</b>
1000BaseSX MMF	62.5	160	2 to 220 (see Note 2)	-9.5 to -4	-17	850
1000BaseSX MMF	62.5	200	2 to 275 (see Note 3)	-9.5 to -4	-17	850
1000BaseSX MMF	50	400	2 to 500	-9.5 to -4	-17	850
1000BaseSX MMF	50	500	2 to 550 (see Note 4)	-9.5 to -4	-17	850
1000BaseLX MMF	62.5	500	2 to 550 (see Note 5)	-5.2 to 0	-22	1300
1000BaseLX MMF	50	400	2 to 550 (see Note 5)	-5.2 to 0	-22	1300
1000BaseLX MMF	50	500	2 to 550 (see Note 5)	-5.2 to 0	-22	1300
1000BaseLX SMF	9	N/A	2 to 10000	-5.2 to 0	-22	1300
1000BaseXD SMF	9	N/A	Up to 50 Km	-5.2 to 0	-24	1550
1000BaseZX SMF	9	N/A	Up to 70 Km	0 to 5.2	-22	1550
1000BaseAPD SMF	9	N/A	Up to 96 Km (see Note 6)	+2 to +6	-28	1550

Note 1: Multimode fiber = MMF; single mode fiber = SMF

Note 2: The TIA 568 building wiring standard calls for 160/500 MHz-Km multimode fiber

Note 3: The international ISO/IEC 11801 building wiring standard calls for 200/500 MHz-Km multimode fiber

Note 4: The ANSI Fibre Channel specification calls for 500/500 MHz/Km 50 micron multimode fiber and 500/500 fiber will be proposed for addition to ISO/IEC 11801

Note 5: Using LX optics on multimode fiber may require the use of DMD-compensating patch cords

Note 6: CWDM GBICs require a minimum of 5dB attenuation between transmitter and receiver. Safety margin includes normal 3dB plus 2.4 Sigma value for CWDM variation. Maximum distance is only achievable without OADM and OMUX in the path

"Gigabit Ethernet flux budget and loss characteristics" (page 107) lists the flux budget, loss, and safety margin characteristics for each transceiver type.

#### Gigabit Ethernet flux budget and loss characteristics

Transceiver	Flux Budget (dB)	Patch Loss (dB)	Remaining Flux Budget (dB)	Fiber Loss (dB/Km)	Flux Budget with Safety Margin (dB)	Sug. Safety Margin (dB)	Max. Fiber Length / Sug. Max. Fiber Length (Km)
1000BaseSX	7.5	1.0	6.5	3.5	3.5	3.0	1.9 / 1.0
1000BaseSX	7.5	1.0	6.5	3.5	3.5	3.0	1.9 / 1.0
1000BaseSX	7.5	1.0	6.5	3.5	3.5	3.0	1.9 / 1.0
1000BaseSX	7.5	1.0	6.5	3.5	3.5	3.0	1.9 / 1.0
1000BaseLX	16.8	1.0	15.8	1.0	12.8	3.0	15.8 / 12.8
1000BaseLX	16.8	1.0	15.8	1.5	12.8	3.0	10.5 / 8.5
1000BaseLX	16.8	1.0	15.8	1.5	12.8	3.0	10.5 / 8.5
1000BaseLX	16.8	1.0	15.8	0.4	12.8	3.0	39.5 / 32.0
1000BaseXD	18.8	1.0	17.8	0.4	14.8	3.0	44.5 / 37.0
1000BaseZX	22	1.0	21.0	0.3	18.0	3.0	70.0 / 60.0
1000BaseAPD	30	1.0	29.0	0.3	23.6	5.4	96.7 / 78.7

#### 1000BaseT GBIC

##### Cable specifications

Type: Category 5 copper unshielded twisted pair (UTP)  
 Maximum distance: 328 ft (100m)

## 8608GTE and 8608GTM modules

### Physical specifications

Height:  
1.5 in. (3.8 cm)

Width:  
15.4 in. (39.1 cm)

Depth:  
18.5 in. (47.0 cm)

Weight:  
8.0 lb (3.6 kg)

**Electrical specifications**

Input power:  
100 W maximum

Thermal rating:  
344 Btu/hr maximum

**MTBF rating**  
180 449 hr

**Connector type**

RJ-45 (see ["Pin assignments: 8608GTE/8608GTM module port" \(page 108\)](#))

**Cable specifications**

Type:  
Category 5 or better UTP cable for 1000 Mb/s operation. Cables must use all four pairs. Wiring configuration and performance are defined by EIA/TIA Standard 568 and IEEE Standard 802.3 2000 edition.

Maximum distance:  
328 ft (100 m)

**Port connectors**

The ports on the 8608GTE and 8608GTM modules are RJ-45 ports wired as shown in ["Pin assignments: 8608GTE/8608GTM module port" \(page 108\)](#).

**Pin assignments: 8608GTE/8608GTM module port**

Connector	Pin number	Signal
	1	Bidirectional Data A + (BI_DA+)
	2	Bidirectional Data A – (BI_DA–)
	3	Bidirectional Data B + (BI_DB+)
	4	Bidirectional Data C + (BI_DC+)
	5	Bidirectional Data C – (BI_DC–)
	6	Bidirectional Data B – (BI_DB–)

Connector	Pin number	Signal
	7	Bidirectional Data D + (BI_DD+)
	8	Bidirectional Data D – (BI_DD–)

## 8608SXE module

### Physical specifications

Height:

1.5 in. (3.8 cm)

Width:

15.4 in. (39.1 cm)

Depth:

18.5 in. (47.0 cm)

Weight:

8.0 lb (3.6 kg)

### Electrical specifications

Input power:

65 W maximum

Thermal rating:

224 Btu/hr maximum

### MTBF rating

197 887 hr

### Connector type

Duplex SC

### Cable specifications

Type:

62.5 µm or 50 µm multimode fiber optic cable

Maximum distance:

62.5 µm multimode fiber optic cable:

722 ft (220 m) @ 160 MHz/km bandwidth

902 ft (275 m) @ 200 MHz/km bandwidth

50  $\mu$ m multimode fiber optic cable:

1640 ft (500 m) @ 400 MHz/km bandwidth

1804 ft (550 m) @ 400 MHz/km bandwidth

### Optical specifications

Wavelength:  
850 nm

Optical budget:  
7 dB

Laser transmitter characteristics:  
Minimum launch power: -10 dBm

Maximum launch power: -4 dBm

Receiver characteristics:  
Minimum receiver sensitivity: -17 dBm

Maximum input power: 0 dBm

## 8616GTE module

### Physical specifications

Height:  
1.5 in. (3.8 cm)

Width:  
15.4 in. (39.1 cm)

Depth:  
18.5 in. (47.0 cm)

Weight:  
8.0 lb (3.6 kg)

### Electrical specifications

Input power:  
100 W maximum

Thermal rating:  
344 Btu/hr maximum

**MTBF rating**

147 602 hr

**Connector type**

RJ-45 (see "Pin assignments: 8616GTE module port" (page 111))

**Cable specifications**

Type:

Category 5 or better UTP cable for 1000 Mb/s operation. Cables must use all four pairs. Wiring configuration and performance are defined by EIA/TIA Standard 568 and IEEE Standard 802.3 2000 edition.

Maximum distance:

328 ft (100 m)

**Port connectors**

The ports on the 8616GTE module are RJ-45 ports wired as shown in "Pin assignments: 8616GTE module port" (page 111).

**Pin assignments: 8616GTE module port**

Connector	Pin number	Signal
	1	Bidirectional Data A + (BI_DA+)
	2	Bidirectional Data A – (BI_DA–)
	3	Bidirectional Data B + (BI_DB+)
	4	Bidirectional Data C + (BI_DC+)
	5	Bidirectional Data C – (BI_DC–)
	6	Bidirectional Data B – (BI_DB–)
	7	Bidirectional Data D + (BI_DD+)
	8	Bidirectional Data D – (BI_DD–)

**8616SXE module****Physical specifications**

Height:

1.5 in. (3.8 cm)

Width:

15.4 in. (39.1 cm)

Depth:

18.5 in. (47.0 cm)

Weight:

8.0 lb (3.6 kg)

### Electrical specifications

Input power:  
115 W maximum

Thermal rating:  
396 Btu/hr maximum

### MTBF rating

178 403 hr

### Connector type

MT-RJ

### Cable specifications

Type:  
62.5  $\mu$ m or 50  $\mu$ m multimode fiber optic cable

Maximum distance:  
62.5  $\mu$ m multimode fiber optic cable:

722 ft (220 m) @ 160 MHz/km bandwidth

902 ft (275 m) @ 200 MHz/km bandwidth

50  $\mu$ m multimode fiber optic cable:

1640 ft (500 m) @ 400 MHz/km bandwidth

1804 ft (550 m) @ 400 MHz/km bandwidth

### Optical specifications

Wavelength:  
850 nm

Optical budget:  
7 dB

Laser transmitter characteristics:  
Minimum launch power: -10 dBm

Maximum launch power: -4 dBm



Receiver characteristics:  
Minimum receiver sensitivity: -17 dBm

Maximum input power: 0 dBm

## 8624FXE module

### Physical specifications

Height:  
1.5 in. (3.8 cm)

Width:  
15.4 in. (39.1 cm)

Depth:  
18.5 in. (47.0 cm)

Weight:  
7.6 lb (3.4 kg)

### Electrical specifications

Input power:  
56 W maximum

Thermal rating:  
193 Btu/hr maximum

**MTBF rating**  
320 972 hr

**Connector type**  
MT-RJ

### Cable specifications

Type:  
62.5  $\mu$ m multimode fiber optic cable

Distance:  
6 562 ft (2 km) for full-duplex links

### Optical specifications

Wavelength:  
1300 nm

Optical budget:

-20 dBm to -14 dBm

Transmitter characteristics:

Minimum optical power: -19 dBm

Maximum optical power: -14 dBm

Receiver characteristics:

Minimum receiver sensitivity: -34 dBm

Maximum input power: -14 dBm

## 8630GBR module

### Physical specifications

Height:

1.5 in. (3.8 cm)

Width:

15.4 in. (39.1 cm)

Depth:

18.5 in. (47.0 cm)

Weight:

8.0 lb (3.6 kg)

### Electrical specifications

Input power:

180 W maximum

Thermal rating:

614 Btu/hr maximum

### MTBF rating

177 525 hr

### Connector type

SC (fiber) or RJ-45 (copper)

## Gigabit Ethernet SFP transceivers

### Physical specifications

Height: 0.53 in. 13.4 mm

Width: 0.33 in. 8.5 mm

**Physical specifications**

Depth: 2.22 in 54.4 mm

Weight: Varies with transceiver type

**Connector type**

Multimode fiber optic: LC or MT-RJ

Single-mode fiber optic: LC

**8632TXE and 8632TXM modules****Physical specifications**

Height:

1.5 in. (3.8 cm)

Width:

15.4 in. (39.1 cm)

Depth:

18.5 in. (47.0 cm)

Weight:

9 lb (4 kg)

**Electrical specifications**

Input power:

100 W maximum

Thermal rating:

193 Btu/hr maximum

**MTBF rating**

217 744 hr

**Connector type**

RJ-45 connector wired as MDI-X

SC duplex connectors on GBICs; see GBIC descriptions beginning on "GBICs" (page 116).

**Cable specifications**

Type:

Category 3, 4, or 5 UTP cable (10 Mb/s operation)

Category 5 UTP cable (100 Mb/s operation)

Maximum distance:

328 ft (100 m) for 10/100 Mb/s ports

For GBIC ports, distance varies with the GBIC; see GBIC descriptions beginning on "GBICs" (page 116).

## GBICs

### Physical specifications

Height:	12 mm
Width:	30 mm
Depth:	65 mm
Weight:	Varies with transceiver type

**Connector type** Duplex SC

See "Gigabit Ethernet minimum distance ranges" (page 106) for a list of Gigabit Ethernet standard minimum distance ranges.

## 1000BaseT transceiver

### Cable specifications

Type:	Category 5 copper unshielded twisted pair (UTP)
Maximum distance:	328 ft (100m)

## 8648GTR module

### Physical specifications

Height:  
1.5 in. (3.8 cm)

Width:  
15.4 in. (39.1 cm)

Depth:  
18.5 in. (47.0 cm)

Weight:  
8.0 lb (3.6 kg)

### Electrical specifications

Input power:

180 W maximum

Thermal rating:  
614 Btu/hr maximum

**MTBF rating**

190 803 hr

**Connector type**

RJ-45 connector (see "Pin assignments: 8648GTR module port" (page 117))

**Cable specifications**

Type:

Category 3, 4, or 5 for 10 Mb/s operation.

Category 5 or better UTP cable for 100 Mb/s and 1000 Mb/s operation. Cables must use all four pairs. Wiring configuration and performance are defined by EIA/TIA Standard 568 and IEEE Standard 802.3 2000 edition.

Maximum distance:

328 ft (100 m)

**Port connectors**

The ports on the 8648GTR module are RJ-45 ports ("Pin assignments: 8648GTR module port" (page 117)).

**Pin assignments: 8648GTR module port**

Connector	Pin number	Signal
	1	Bidirectional Data A + (BI_DA+)
	2	Bidirectional Data A - (BI_DA-)
	3	Bidirectional Data B + (BI_DB+)
	4	Bidirectional Data C + (BI_DC+)
	5	Bidirectional Data C - (BI_DC-)
	6	Bidirectional Data B - (BI_DB-)
	7	Bidirectional Data D + (BI_DD+)
	8	Bidirectional Data D - (BI_DD-)

**8648TXE and 8648TXM modules**

**Physical specifications**

Height:

1.5 in. (3.8 cm)

Width:

15.4 in. (39.1 cm)

Depth:

18.5 in. (47.0 cm)

Weight:

8.0 lb (3.6 kg)

### Electrical specifications

Input power:

76 W maximum

Thermal rating:

261 Btu/hr maximum

### MTBF rating

244 708 hr

### Connector type

RJ-45 connector wired as MDI-X (see "Pin assignments: 8648TXE/8648TXM module port" (page 118))

### Cable specifications

Type:

Category 3, 4, or 5 UTP cable (10 Mb/s operation)

Category 5 UTP cable (100 Mb/s operation)

Maximum distance:

328 ft (100 m)

### Port connectors

The ports on both the 8648TXE and 8648TXM modules are RJ-45 ports wired as MDI-X connectors ("Pin assignments: 8648TXE/8648TXM module port" (page 118)).

#### Pin assignments: 8648TXE/8648TXM module port

Connector	Pin number	Signal
	1	Input receive data + (RX+)
	2	Input receive data - (RX-)
	3	Output transmit data + (TX+)
	6	Output transmit data - (TX-)
	4, 5, 7, 8	Not used

---

## ESM 8668 Metro Ethernet Services Module

### Physical specifications

Height:  
1.5 in. (3.8 cm)

Width:  
15.4 in. (39.1 cm)

Depth:  
18.5 in. (47.0 cm)

Weight:  
11.4 lbs (5.17 kg)

### Electrical specifications

Input power:  
100 W

Thermal rating:  
0 - 50°C

### MTBF rating

162 000 hr

### Connector types

Pluggable Small Form Factor Optics (SFP) modules

### Cable specifications

SFP modules support LC terminated optic cables

## 8672ATME and 8672ATMM modules

### Physical specifications

Height:  
1.5 in. (3.8 cm)

Width:  
15.4 in. (39.1 cm)

Depth:  
18.5 in. (47.0 cm)

Weight:  
8.0 lb (3.6 kg)

### Electrical specifications

Input power:

OC-3c MDA: 40 W maximum

OC-12c MDA: 40 W maximum

DS-3 MDA: 40 W maximum

Thermal rating:

OC-3c MDA: 138 Btu/hr maximum

OC-12c MDA: 138 Btu/hr maximum

DS-3 MDA: 138 Btu/hr maximum

### MTBF rating

222 103 hr

### Connector type

OC-3c MDA: MT-RJ

OC-12c MDA: Duplex SC

DS-3 MDA: BNC

### Cable specifications

Type:

Multimode or single-mode fiber optic cable, coaxial cable

Maximum distance:

Multimode fiber optic cable:

1.24 mi (2 km) for OC-3c connection

1640 ft (500 m) for OC-12c connection

Single-mode fiber optic cable:

9.3 mi (15 km) for OC-3c connection



9.3 mi (15 km) for OC-12c connection

Coaxial cable: 450 ft (137 m) for DS-3 connection

### **Optical specifications**

Wavelength:

OC-3c MDA SMF: 1274 to 1356 nm

OC-3c MDA MMF: 1274 to 1356 nm

OC-12c MDA SMF: 1274 to 1356 nm

OC-12c MDA MMF: 1260 to 1360 nm

Average transmit output power:

OC-3c and OC-12c MDAs SMF: -8 to -15 dBm

OC-3c and OC-12c MDAs MMF: -14 to -29 dBm

Average receiver sensitivity:

OC-3c MDA SMF: -14 to -28 dBm

OC-3c MDA MMF: -14 to -29 dBm

OC-12c MDA SMF: -7 to -18 dBm

OC-12c MDA MMF: -14 to -28 dBm

## **8681XLR module**

### **Physical specifications**

Height:

1.5 in. (3.8 cm)

Width:

15.4 in. (39.1 cm)

Depth:

18.5 in. (47.0 cm)

Weight:

8.0 lb (3.6 kg)

### **Electrical specifications**

---

Nortel Metro Ethernet Routing Switch 8600  
Installation — Modules  
NN46220-306 02.02 Standard  
4.2 7 July 2008

Input power:  
150 W maximum

Thermal rating:  
512 BTU/hr maximum

**MTBF rating**

140 000 hr

**Data Rate and encoding**

64b/66b (IEEE 802.3ae specified)

**Compatible with STM-64**

No

**Module Performance**

**(64 byte packets)**

Aggregate throughput  
8x1,488,100 pps

Routing and Switch Forwarding Rates  
8x1,488,100 pps

**Connector type**

SC Duplex

**Port type**

10GBaseLR 1310nm serial PMD

**Cable specifications**

Type:  
9/125  $\mu$ m single mode fiber optic cable

Distance:  
6.2 miles (10 km)

**Optical specifications**

Wavelength:  
1310 nm

Optical budget:  
5 dB

Transmitter characteristics:  
Minimum optical power: -6 dBm

Maximum optical power: -1 dBm

Receiver characteristics:  
Minimum receiver sensitivity: -12 dBm

Maximum input power: -1 dBm

## 8681XLW module

### Physical specifications

Height:  
1.5 in. (3.8 cm)

Width:  
15.4 in. (39.1 cm)

Depth:  
18.5 in. (47.0 cm)

Weight:  
8.0 lb (3.6 kg)

### Electrical specifications

Input power:  
150 W maximum

Thermal rating:  
512 BTU/hr maximum

### MTBF rating

140 000 hr

### Data Rate and encoding

64b/66b (IEEE 802.3ae specified)

### Compatible with STM-64

Yes

### Module Performance (64 byte packets)

Aggregate throughput  
8x1 488 100 pps

Routing and Switch Forwarding Rates  
8x1 488 100 pps

**Connector type**

SC Duplex

**Port type**

10GBaseLW 1310nm serial PMD

**Cable specifications**

Type:

9/125  $\mu$ m single mode fiber optic cable

Distance:

6.2 miles (10 km)

**Optical specifications**

Wavelength:

1310 nm

Optical budget:

5 dB

Transmitter characteristics:

Minimum optical power: -6 dBm

Maximum optical power: -1 dBm

Receiver characteristics:

Minimum receiver sensitivity: -12 dBm

Maximum input power: -1 dBm

## 8683POSM module

**Physical specifications**

Height:

1.5 in. (3.8 cm)

Width:

15.4 in. (39.1 cm)

Depth:

18.5 in. (47.0 cm)

Weight:

**Electrical specifications**

---

Input power:

OC-3c MDA: 70 W maximum

OC-12c MDA: 90 W maximum

Thermal rating:

OC-3c MDA: 241 Btu/hr maximum

OC-12c MDA: 310 Btu/hr maximum

### **MTBF rating**

255 693 hr

### **Connector types**

OC-3c MDA: MT-RJ

OC-12c MDA: Duplex SC

### **Cable specifications**

Type:

Multimode or single-mode fiber optic cable

Maximum distance:

Multimode fiber optic cable:

1.24 mi (2 km) for OC-3c connection

1640 ft (500 m) for OC-12c connection

Single-mode fiber optic cable:

9.3 mi (15 km) for OC-3c connection

9.3 mi (15 km) for OC-12c connection

### **Optical specifications**

Wavelength:

OC-3c MDA SMF: 1274 to 1356 nm

OC-3c MDA MMF: 1274 to 1356 nm

OC-12c MDA SMF: 1274 to 1356 nm

OC-12c MDA MMF: 1260 to 1360 nm

Average transmit output power:

OC-3c and OC-12c MDAs SMF: -8 to -15 dBm

OC-3c and OC-12c MDAs MMF: -14 to -29 dBm

Average receiver sensitivity:

OC-3c MDA SMF: -14 to -28 dBm

OC-3c MDA MMF: -14 to -29 dBm

OC-12c MDA SMF: -7 to -18 dBm

OC-12c MDA MMF: -14 to -28 dBm

## 8683XLR module

### Physical specifications

Height:

1.5 in. (3.8 cm)

Width:

15.4 in. (39.1 cm)

Depth:

18.5 in. (47.0 cm)

Weight:

8.0 lb (3.6 kg)

### Electrical specifications

Input power:

180 W maximum

Thermal rating:

614 BTU/hr maximum

### MTBF rating

184 230 hr

### Data Rate and encoding

10.3125 Gb/s with 64b/66b encoding

**Compatible with STM-64**

No

**Module Performance  
(64 byte packets)**Aggregate throughput  
3x14 880 952 ppsRouting and Switch Forwarding Rates  
14 880 952 pps**Connector type**

LC Duplex

**Port type**

10GBaseR

**XFPs****Physical specifications**

Height:	12.5 mm
Width:	18.35 mm
Depth:	71.1 mm
Weight:	Varies with XFP type
	LC Duplex

**Connector type****8683XZR module****Physical specifications**Height:  
1.5 in. (3.8 cm)Width:  
15.4 in. (39.1 cm)Depth:  
18.5 in. (47.0 cm)Weight:  
8.0 lb (3.6 kg)**Electrical specifications**

Nortel Metro Ethernet Routing Switch 8600  
Installation — Modules  
NN46220-306 02.02 Standard  
4.2 7 July 2008





Width:  
15.4 in. (39.1 cm)

Depth:  
18.5 in. (47.0 cm)

Weight:  
7.2 lb (3.3 kg)

### **Electrical specifications**

Input power:  
90 W

Thermal rating:  
0 - 50°C

**MTBF rating**  
183 737 hr

### **Connector types**

Ethernet Management port:  
RJ-45 connector wired as MDI (see "[Pin assignments: 8691omSF module Management port](#)" (page 130))

Console port:  
DB-9 connector (see "[Pin assignments: 8691omSF module Console port](#)" (page 130))

Modem port:  
DB-9 connector (see "[Pin assignments: DTE to DCE](#)" (page 131))

### **Cable specifications**

Ethernet Management port:  
Category 3, 4, or 5 UTP cable (10 Mb/s operation)

Category 5 UTP cable (100 Mb/s operation)

Console port:  
RS-232 cable

Modem port:  
DTE-to-DCE cable (straight or transmit cable)

### **Management port**

The Management port is a 10/100 Mb/s Ethernet port implemented on an RJ-45 connector wired as an MDI connection.

"Pin assignments: 8691omSF module Management port" (page 130) shows the pin assignments for this connector.

#### Pin assignments: 8691omSF module Management port

Connector	Pin number	Signal
	1	Output transmit data + (TX+)
	2	Output transmit data - (TX-)
	3	Input receive data + (RX+)
	6	Input receive data - (RX-)
	4, 5, 7, 8	Not used

#### Console serial port

The Console serial port is implemented as a DB-9 connector. This port can operate as a data terminal equipment (DTE) or data communication equipment (DCE) device. Use the switch to the left of the port to set the port to DTE (right) or DCE (left). Default settings for this port are 9600 bits/s, 8 data bits, no parity, and one stop bit.

Connection to TXD and RXD signals and GND is sufficient for the console serial port to fully function. The Console port does not support any inbound flow control; that is, the port does not toggle control lines to indicate an input buffer full condition.

"Pin assignments: 8691omSF module Console port" (page 130) lists the pin assignments for the Console port for both the DTE and DCE settings.

#### Pin assignments: 8691omSF module Console port

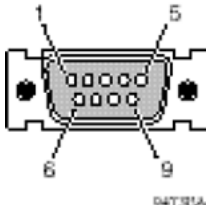
Connector	Pin number	Switch position	
		DCE (left)	DTE right)
	2	TXD (Output)	RXD (Input)
	3	RXD (Input)	TXD (Output)
	4	DSR (Input)	DTR (Output)
	5	GND	GND
	6	DTR (Output)	DSR (Input)
	7	CTS (Input)	RTS (Output)
	8	RTS (Output)	CTS (Input)
		9	

#### Modem serial port

The Modem serial port is implemented on a DB-9 connector wired as a DTE connection.

To set up modem access, you need a DTE-to-DCE cable ( straight or transmit cable) between the Modem port and a modem or terminal server.

"Pin assignments: DTE to DCE" (page 131) describes the required cable pin assignments.

**Pin assignments: DTE to DCE**

Switch		Modem	
Signal	Pin number	DCE DB-9 pin number	DCE DB-25 pin number
RXD	2	2	3
TXD	3	3	2
DTR	4	4	20
GND	5	5	7
DSR	6	6	6
RTS	7	7	4
CTS	8	8	5

## 8692omSF module

### Physical specifications

Height:  
1.5 in. (3.8 cm)

Width:  
15.4 in. (39.1 cm)

Depth:  
18.5 in. (47.0 cm)

Weight:  
7.2 lb (3.3 kg)

### Electrical specifications

Input power:  
90 W maximum

Thermal rating:  
241 Btu/hr maximum

**MTBF rating**  
355 643 hr

### Connector types

Ethernet Management port:  
RJ-45 connector wired as MDI (see "Pin assignments: 8692omSF module" (page 132))

Console port:  
DB-9 connector (see "Pin assignments: 8692omSF module Console port" (page 133))

Modem port:  
DB-9 connector (see "Pin assignments: DTE to DCE" (page 133))

### Cable specifications

Ethernet Management port:  
Category 3, 4, or 5 UTP cable (10 Mb/s operation)

Category 5 UTP cable (100 Mb/s operation)

Console port:  
RS-232 cable

Modem port:  
DTE-to-DCE cable (straight or transmit cable)

### Management port

The Management port is a 10/100 Mb/s Ethernet port implemented on an RJ-45 connector wired as an MDI connection.

"Pin assignments: 8692omSF module" (page 132) shows the pin assignments for this connector.

#### Pin assignments: 8692omSF module

Connector	Pin number	Signal
	1	Output transmit data + (TX+)
	2	Output transmit data - (TX-)
	3	Input receive data + (RX+)
	6	Input receive data - (RX-)
	4, 5, 7, 8	Not used

### Console serial port

The Console serial port is implemented as a DB-9 connector. This port can operate as a data terminal equipment (DTE) or data communication equipment (DCE) device. Use the switch to the left of the port to set the port to DTE (right) or DCE (left). Default settings for this port are 9600 bits/s, 8 data bits, no parity, and one stop bit.

Connection to TXD and RXD signals and GND is sufficient for the console serial port to fully function. The Console port does not support any inbound flow control; that is, the port does not toggle control lines to indicate an input buffer full condition.

"Pin assignments: 8692omSF module Console port" (page 133) lists the pin assignments for the Console port for both the DTE and DCE settings.

#### Pin assignments: 8692omSF module Console port

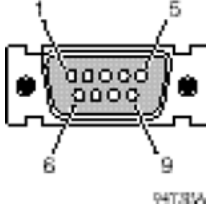
Connector	Pin number	Switch position	
		DCE (left)	DTE right)
	2	TXD (Output)	RXD (Input)
	3	RXD (Input)	TXD (Output)
	4	DSR (Input)	DTR (Output)
	5	GND	GND
	6	DTR (Output)	DSR (Input)
	7	CTS (Input)	RTS (Output)
	8	RTS (Output)	CTS (Input)

#### Modem serial port

The Modem serial port is implemented on a DB-9 connector wired as a DTE connection.

To set up modem access, you need a DTE-to-DCE cable (straight or transmit cable) between the Modem port and a modem or terminal server.

"Pin assignments: DTE to DCE" (page 133) describes the required cable pin assignments.

#### Pin assignments: DTE to DCE

Switch		Modem	
Signal	Pin number	DCE DB-9 pin number	DCE DB-25 pin number
RXD	2	2	3
TXD	3	3	2
DTR	4	4	20
GND	5	5	7
DSR	6	6	6
RTS	7	7	4
CTS	8	8	5



---

## Appendix B

# Installing the Metro Ethernet enhanced CPU daughter card

---

This appendix describes how to install the optional Metro Ethernet enhanced CPU daughter card (hereafter referred to as the daughter card or SuperMezz) on the 8692 Series CPU modules (8692SF and 8692omSF) .

The SuperMezz is a mezzanine daughter card that consists of dual 1 GHz Power PC processors. Installing the daughter card on an 8692 Series module offloads processor-intensive tasks from the 333 MHz processor located on the 8692 CPU.

### Prerequisites

- All Metro Ethernet Services Modules (Metro ESM 8668) in your chassis must have a jumper installed.



#### CAUTION

Before installing the SuperMezz, all Metro ESM 8668 modules in your chassis must have a jumper installed. See "[Installing the jumper on an ESM 8668](#)" (page 139) for directions on how to install the jumper.

- The SuperMezz is only supported on the 8692 Series CPU modules.
- The SuperMezz is required for Provider Backbone Transport (PBT) services.
- In a system with two 8692SF CPU modules (or two 8692omSF CPU modules), you must install a SuperMezz on both CPU modules.
- Do the following to protect your equipment from electrostatic discharge.



**CAUTION**

Electrostatic discharge can damage hardware.

The 8692 Series CPU modules are sensitive to static electricity. Be aware that electrostatic discharge from your clothing or other fixtures around you, even at levels that do not create a spark, can cause damage to the module components.

To prevent static discharge:

- Always place each module on a grounded antistatic mat until you are ready to perform the upgrade or leave the module in the sealed ESD bag.
- Always wear a static discharge leash or an antistatic wrist strap to free yourself of electrostatic charges before you touch a module.

## Procedure steps

Step	Action
1	If you have one or more Metro ESM 8668 installed, you need to install a jumper on each Metro ESM 8668 before installing the SuperMezz. Follow the procedure " <a href="#">Installing the jumper on an ESM 8668</a> " (page 139) before continuing with the next step.
2	Locate the CPU daughter card installation kit and remove the CPU daughter card and installation hardware (see " <a href="#">CPU daughter card installation kit</a> " (page 137)).  Be sure your shipment includes all of the items shown in " <a href="#">CPU daughter card installation kit</a> " (page 137).



### CPU daughter card installation kit

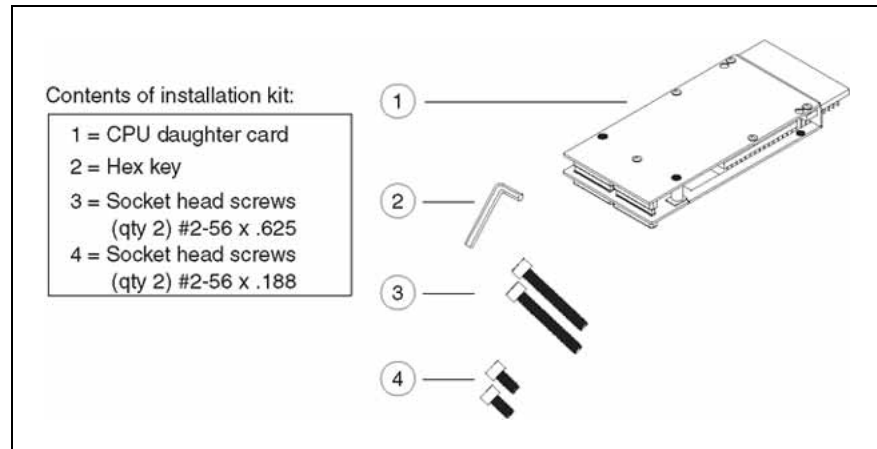

- 3 Remove the 8692 Series CPU from the chassis (see ["Installing and replacing a module" \(page 75\)](#)).
- 4 Pick up the daughter card.
- 5 Align the daughter card connectors with the connectors on the 8692 Series CPU ( see ["Aligning the CPU daughter card connectors" \(page 137\)](#)).

### Aligning the CPU daughter card connectors

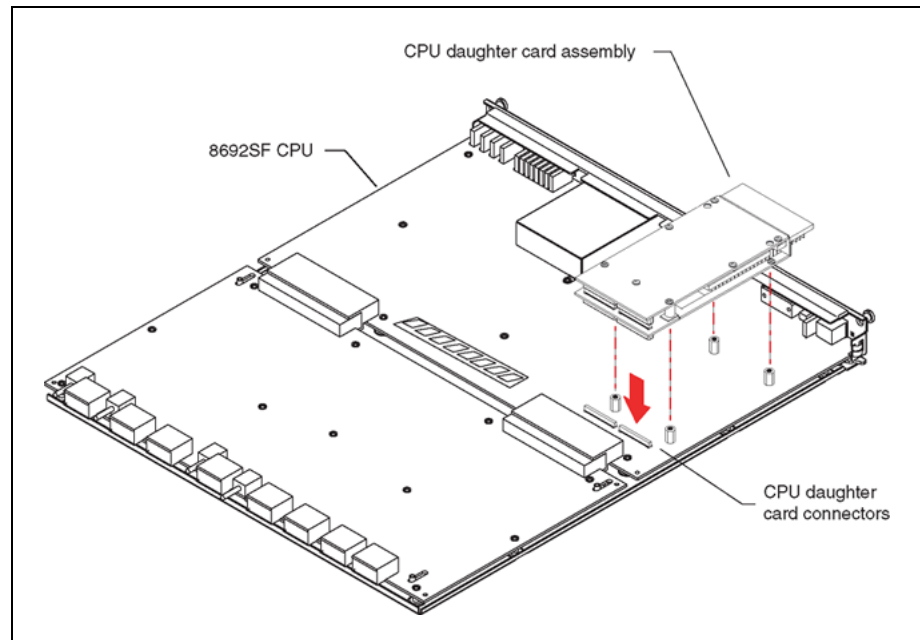

- 6 Press the daughter card assembly into the connectors on the 8692SF CPU (see "Mounting the CPU daughter card assembly to the 8692 Series CPU" (page 138)).

#### Mounting the CPU daughter card assembly to the 8692 Series CPU

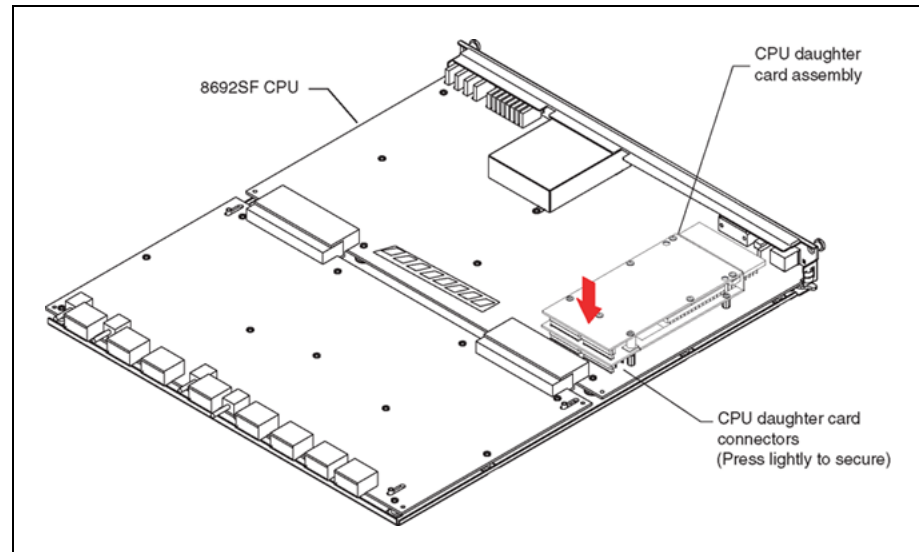

Make sure that the daughter card is properly seated in the connectors.

- 7 Using the hex key, secure the daughter card to the 8692 Series CPU using four socket head screws (items 3 and 4 in the installation kit) (see "Securing the daughter card to the 8692 Series CPU" (page 139)).

Install the #2-56 x .625 screws first, followed by the #2-56 x .188 screws. See "Securing the daughter card to the 8692 Series CPU" (page 139) for correct screw placement. You must insert the shorter screws in the oval holes in the sheet metal daughter card bracket and not through the daughter card. After you place the screw in the hole, insert the hex key through the daughter card hole to secure the screw in place.



#### CAUTION

Do not overtighten the screws. It is normal for a slight space to be visible between the daughter card and the standoffs.

### Securing the daughter card to the 8692 Series CPU

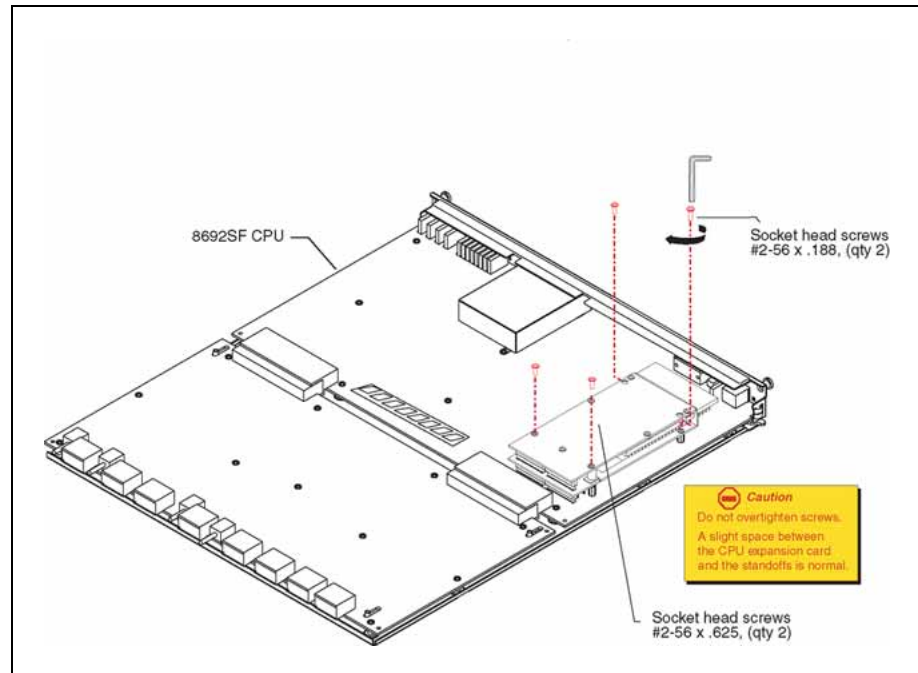

- 8 Replace the 8692 Series CPU (with the newly installed daughter card attached) into the vacant chassis slot (see "Installing and replacing a module" (page 75)).

After you replace the 8692 Series CPU into the chassis, see the appropriate chassis and component installation guide to power up the chassis and verify a successful installation.

—End—

### Installing the jumper on an ESM 8668

Install a jumper on the Metro Ethernet Services Module (Metro ESM 8668) to ensure that the ESM 8668 boots successfully when a SuperMezz is installed.

All ESM 8668 boards in your chassis must have a jumper installed.

#### Prerequisites

- Have the jumpers ready to install. You can order jumpers from Nortel with the *MERS 8600 ESM Jumper Kit* (DS1411033-E6).

## Procedure steps

Step	Action
------	--------

- |   |  |
|---|--|
| 1 | Disable the slot where the ESM 8668 is installed by using the CLI command. Specify the number of the slot where the ESM 8668 is installed for <slot-number>. |
|---|--|

```
conf slot <slot-number> state dis
```

If you remove the ESM 8668 while active, ring failover times may be longer than expected. Disabling the slot before removing the ESM 8668 provides a clean disconnect from all services.

- |   |   |
|---|---|
| 2 | Remove the ESM 8668 from the chassis (see <a href="#">"Installing and replacing a module" (page 75)</a> ).  |
| 3 | Locate the 2x8 connector header, labeled P1, on the ESM 8668. See <a href="#">"ESM 8668, P1 connector header" (page 140)</a> for the location of the P1 connector header. |

### ESM 8668, P1 connector header

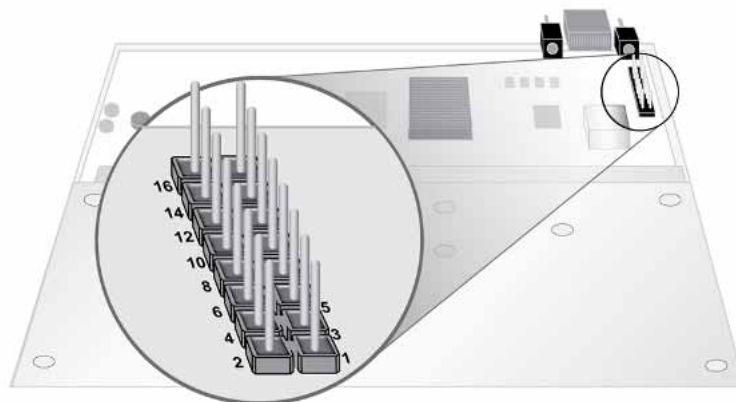

- |   |  |
|---|--|
| 4 | Identify pins 5 and 6 on the P1 connector header where the jumper gets installed. See <a href="#">"P1 connector header, pins 5 and 6" (page 141)</a> . |
|---|--|

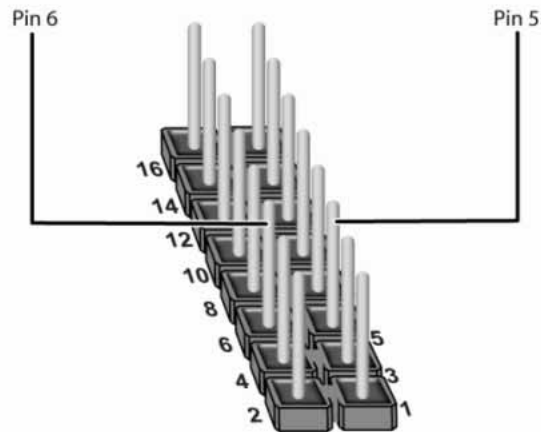
**P1 connector header, pins 5 and 6**

- 5 Align the jumper contacts with pins 5 and 6 of the P1 connector header.
- 6 Slide the jumper onto pins 5 and 6 until the jumper meets the connector header (see ["P1 connector header with jumper installed"](#) (page 141)).

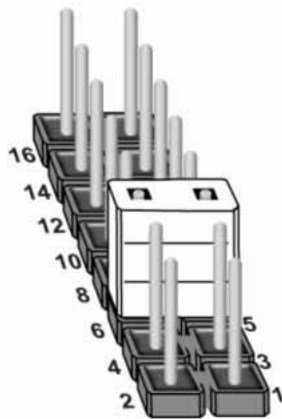
**P1 connector header with jumper installed**

- 7 Replace the ESM 8668 into the chassis (see ["Installing and replacing a module"](#) (page 75)).
- 8 Enable the slot to activate the ESM 8668 using the CLI command. Specify the number of the slot where the ESM 8668 is installed for <slot-number>.

```
conf slot <slot-number> state en
```

- 9 You are done with installing the jumper on the ESM 8668 module. Repeat this procedure for all ESM 8668 boards in your chassis.

To determine if a jumper is properly installed on an ESM 8668, perform a visual inspection or contact a customer service representative.

---

—End—

---

---

# Index

---

## Symbols/Numerics

- 10/100 Mb/s ports 41
- 10/100BaseT interface, connecting to 88
- 1000BaseT GBIC
  - technical specifications 107, 116
- 100BaseFX ports 35
- 8600 modules
  - 8608GBE 25
  - 8608GBM 25
  - 8608GTE 27
  - 8608GTM 27
  - 8608SXE 30
  - 8616GTE 32
  - 8616SXE 33
  - 8624FXE 35
  - 8630GBR 37
  - 8632TXE 41
  - 8632TXM 41
  - 8648GTR 44
  - 8648TXE 46
  - 8648TXM 46
  - 8672ATME 50
  - 8672ATMM 50
  - 8681XLR 52
  - 8681XLW 54
  - 8683POSM 56
  - 8683XLR 58
- 8608GBE module
  - description 25
  - installing and replacing 75
  - status LEDs 26,
  - technical specifications 105
- 8608GBM module
  - description 25
  - installing and replacing 75
  - status LEDs 26,
  - technical specifications 105
- 8608GTE module
  - description 27
  - installing and replacing 75
  - status LEDs 28, 28
  - technical specifications 107
- 8608GTM module
  - description 27
  - installing and replacing 75
  - status LEDs 28, 28
  - technical specifications 107
- 8608SXE module
  - description 31
  - installing and replacing 75
  - status LEDs 30
  - technical specifications 109, 109
- 8616GTE module
  - description 32, 32
  - installing and replacing 75
  - status LEDs 32, 32, 32
  - technical specifications 110
- 8616SXE module
  - description 33
  - installing and replacing 75
  - status LEDs 34
  - technical specifications 111
- 8624FXE module
  - description 35, 35
  - installing and replacing 75
  - status LEDs 36
  - technical specifications 114
- 8630GBR module
  - installing and replacing 75
  - status LEDs 26,
  - technical specifications 105

- description 37, 37, 37
- status LEDs 39,
- technical specifications 114
- 8632TXE module
  - description 41, 41, 41
  - installing and replacing 75, 75
  - status LEDs
  - technical specifications 115, 116
- 8632TXM module
  - description 41, 41
  - installing and replacing 75, 75
  - status LEDs
  - technical specifications 116
- 8648GTR module
  - description 44
  - status LEDs
  - technical specifications 116, 117
- 8648TXE module
  - description 46
  - installing and replacing 75
  - status LEDs 46, 46
  - technical specifications 117
- 8648TXM module
  - description 46
  - installing and replacing 75
  - status LEDs 46, 46
  - technical specifications 117
- 8672ATME module
  - description 50
  - installing and replacing 75, 75
  - status LEDs 51, 51
  - technical specifications 119
- 8672ATMM module
  - description 50
  - installing and replacing 75, 75
  - status LEDs 51, 51
  - technical specifications 119
- 8681XLR module
  - description 52, 52, 61
  - installing and replacing 75
  - status LEDs
  - technical specifications 121, 121
- 8681XLW module
  - description 54, 54
  - installing and replacing 75
  - status LEDs 55
  - technical specifications 123, 123, 124
- 8683POSM module
  - description 56
  - installing and replacing 75, 75
  - status LED 57
  - technical specifications 124
- 8683XLR module
  - description 58, 58, 58, 58
  - installing and replacing 75
  - status LEDs 59, , 62
  - technical specifications 126, 127
- 8683XZR module
  - description 61, 61, 61
  - status LEDs
  - technical specifications 127
- 8691omSF module
  - connecting modem to 86
  - description 63
  - installing and replacing 75
  - status LEDs 64
- 8692omSF module
  - connecting modem to 86
  - description 67
  - installing and replacing 75
  - status LEDs 69, 69
  - technical specifications 132

## A

ATM module 50

## C

cable lengths 89

cables

connecting

10/100BaseT 88

to modem 86

crossover 88

fiber optic

8608SXE module 109

8616SXE module 112

8624FXE module 113

8632TXE module 115

8632TXM module 115

8672ATME module 120

8672ATMM module 120

8681XLR module 122

8681XLW module 124



- 8683POSM module 125
  - 8683XLR 58
  - straight-through 88, 131, 133
  - UTP 108, 111, 117, 118
  - chassis
    - components, described 18
  - connecting
    - 10/100BaseT cables 88
    - modem cables 86
  - connecting modem to
    - 8692omSF module 86, 86
  - connectors
    - DB-9 130, 132
    - MDI-X 108, 111, 117, 118
    - RJ-45 130, 132
  - Console port 67, 71, 130, 132
  - CPU subsystem 63
  - crossover cable 88
  - CRUs (customer-replaceable units)
    - 8608GBE module
      - description 25
      - installing and replacing 75, 75
    - 8608GBM module
      - description 25
      - installing and replacing 75
    - 8608GTE module
      - description 27
    - 8608GTM module
      - description 27
    - 8608SXE module
      - description 30
      - installing and replacing 75
    - 8616GTE module
      - description 32
    - 8616SXE module
      - description 33
    - 8624FXE module
      - description 35
      - installing and replacing 75
    - 8630GBR module
      - description 37, 37
    - 8632TXE module
      - description 41
    - 8632TXM module
      - description 41
      - installing and replacing 75
    - 8648GTR module
      - description 44
    - 8648TXE module
      - description 46
      - installing and replacing 75
    - 8648TXM module
      - description 46
      - installing and replacing 75
    - 8681XLR module
      - description 52, 52
    - 8681XLW module
      - description 54
      - installing and replacing 75
    - 8683POSM module
      - description 56, 56
    - 8683XLR module
      - description 58, 58
    - 8683XZR module
      - description 61
    - 8691omSF module
      - description 63
      - installing and replacing 75
    - 8692omSF module
      - description 67
      - installing and replacing 75
- ## D
- downloading image 99, 99, 100
  - DTE/DCE switch 67, 130, 132
    - description 71
- ## E
- environmental specifications
    - routing switch 102
  - ESM 8668 Metro ESM, description 49
  - Ethernet Management port 66, 71
    - pin assignments 130, 132
- ## F
- fan LED 66, 71
  - fiber-optic equipment 76
  - flash memory card 67
- ## G
- Gigabit Ethernet modules 27, 32

**H**

hot-swapping  
modules 76

**I**

installation  
modules 81  
installing and replacing 75

**L**

LEDs  
8608GBE module 26  
8608GBM module 26  
8608GTE module 28  
8608GTM module 28  
8608SXE module 30  
8616GTE module 32  
8616SXE module 34  
8624FXE module 37  
8630GBR module 37, 39  
8632TXE module  
8632TXM module  
8648GTR module  
8648TXE module 46  
8648TXM module 46  
8672ATME module  
8672ATMM module  
8681XLR module 53  
8681XLW module 55  
8683POSM module  
8683XLR module 59, ,  
8683XZR module 62  
8691omSF module 64  
8692omSF module 69, 69  
length, cables 89

**M**

Management port 66, 71, 130, 132  
management, out-of-band 66, 71  
maximum cable distances 89  
MDI-X connections 88  
memory  
output buffer 21  
PC Card 67  
PCMCIA 72

memory card 72  
Mezzanine card  
installing 135  
modem  
connecting to 8010co 86  
Modem port 67  
8691omSF module 71  
modem port 131, 133  
modules  
installing 81  
removing 76  
modules, hot-swapping 76

**O**

optical specifications  
8608SXEmodule 110  
8616SXE module 112  
8624FXE module 113  
8672ATME module 121  
8672ATMM module 121  
8681XLR module 122  
8681XLW module 124  
8683POSM module 125

**P**

PC Card slot 67  
PCMCIA card slot 67, 72  
pin assignments  
10/100 Mb/s ports 108, 111, 117, 118  
Console port ,  
Ethernet Management port 130, 132  
modem port 131, 133  
port densities 18  
ports  
10/100 Mb/s 41, 108, 111, 117, 118  
100BaseFX 35  
Console 130, 132  
Ethernet Management 66, 71, 130, 132  
modem 131, 133  
serial 67, 71  
POSM module 56

**R**

redundancy  
CPUs 64, 69  
removing

modules 76  
reset button 67, 72  
routing switch fabric module  
description 64

## S

safety agency approvals 104  
serial ports 67, 71  
specifications, technical  
8608GBM module 105  
8608GTE module 108  
8608GTM module 108  
8608SXE module 110  
8616GTE module 110, 111  
8616SXE module 113  
8624FXE module 123, 123  
8630GBR module 114  
8632TXE module 116  
8632TXM module 116  
8648GTR module 117  
8648TXE module 118

8648TXM module 118  
8668 MES module 119  
8672ATME module 121  
8672ATMM module 121  
8681XLR module 121  
8681XLW module 123, 123  
8683XLR module 127  
8683XZR module 127  
8691omSF module 129  
869om2SF module 132  
standards 102  
straight-through cable 88, 131, 133

## T

technical specifications  
8600 modules 101  
troubleshooting  
downloading the image file 99  
image download 99, 100  
saving configuration changes 100  
saving your configuration 99





Nortel Metro Ethernet Routing Switch 8600

## Installation — Modules

Copyright © 2005-2007, Nortel Networks  
All Rights Reserved.

Publication: NN46220-306  
Document status: Standard  
Document version: 02.02  
Document date: 7 July 2008

Sourced in Canada and the United States of America

To provide feedback or report a problem in this document, go to [www.nortel.com/documentfeedback](http://www.nortel.com/documentfeedback).

This document is protected by copyright laws and international treaties. All information, copyrights and any other intellectual property rights contained in this document are the property of Nortel Networks. Except as expressly authorized in writing by Nortel Networks, the holder is granted no rights to use the information contained herein and this document shall not be published, copied, produced or reproduced, modified, translated, compiled, distributed, displayed or transmitted, in whole or part, in any form or media.

The information in this document is subject to change without notice. The statements, configurations, technical data, and recommendations in this document are believed to be accurate and reliable, but are presented without express or implied warranty. Users must take full responsibility for their applications of any products specified in this document. The information in this document is proprietary to Nortel Networks Inc.

Nortel, the Nortel logo, and the Globemark are trademarks of Nortel Networks.

3COM is a trademark of 3COM Corporation.

Intel is a trademark of Intel Corporation.

SanDisk is a trademark of SanDisk Corporation.

All other trademarks are the property of their respective owners.



## Free Manuals Download Website

<http://myh66.com>

<http://usermanuals.us>

<http://www.somanuals.com>

<http://www.4manuals.cc>

<http://www.manual-lib.com>

<http://www.404manual.com>

<http://www.luxmanual.com>

<http://aubethermostatmanual.com>

Golf course search by state

<http://golfingnear.com>

Email search by domain

<http://emailbydomain.com>

Auto manuals search

<http://auto.somanuals.com>

TV manuals search

<http://tv.somanuals.com>