



**NORTEL**

Nortel Ethernet Routing Switch 8600

# Quick Start

Release: 5.0

Document Revision: 02.01

[www.nortel.com](http://www.nortel.com)

---

NN46205-310

321749-B Rev 01

Nortel Ethernet Routing Switch 8600  
Release: 5.0  
Publication: NN46205-310  
Document status: Standard  
Document release date: 30 May 2008

Copyright © 2008 Nortel Networks  
All Rights Reserved.

Printed in Canada, India, and the United States of America

#### LEGAL NOTICE

While the information in this document is believed to be accurate and reliable, except as otherwise expressly agreed to in writing NORTEL PROVIDES THIS DOCUMENT "AS IS" WITHOUT WARRANTY OR CONDITION OF ANY KIND, EITHER EXPRESS OR IMPLIED. The information and/or products described in this document are subject to change without notice.

Nortel, the Nortel logo, the Globemark, and Passport are trademarks of Nortel Networks.

All other trademarks are the property of their respective owners.

#### **ATTENTION**

For information about the regulatory and safety precautions, read "Regulatory messages and safety precautions" in this guide.

For information about the software license, read "Software license" in this guide.

For a list of safety messages used in this guide and their translations, see "Translations of safety messages".

---

# Contents

---

<b>Regulatory Information and Safety Precautions</b>	<b>5</b>
<b>Software license</b>	<b>17</b>
<b>New in this release</b>	<b>21</b>
Features	21
Other changes	21
Connecting the modem using the CLI	22
Connecting the modem using the NNCLI	22
Setting the system date and time using the CLI	22
Setting the system date and time using the NNCLI	22
Changing passwords using the CLI	22
Changing passwords using the NNCLI	22
<b>Introduction</b>	<b>23</b>
<b>Installation preparation</b>	<b>25</b>
Ethernet Routing Switch 8600 slots	25
DC power supply accessories	26
Safety precautions	27
Personal safety	27
<b>Installation</b>	<b>31</b>
Unpacking the chassis	32
Removing a power filler panel	33
Installing an Ethernet Routing Switch 8003, 8006, or 8010 chassis into a rack	34
Installing the 8010co chassis in a 19-inch two-post rack	36
Installing the 8003, 8006, and 8010 chassis cable guides	37
Installing the top cable-management bracket	38
Procedure job aid: Installing the cable-management brackets	39
Installing the side cable-management brackets	39
Grounding the 8010co chassis	40
Procedure job aid: Grounding the 8010co chassis	41
Installing a module	41
Procedure job aid: Installing a module	43
Installing AC power modules	43

---

Installing DC power modules	44
Cable preparation	49
Installing a breaker interface panel	49
Installing a PCMCIA software card	49
Starting the system	49
Turning on AC power supplies	49
Turning on DC power supplies	50
LED power supply	51
Verifying a successful installation	51

---

## **Configuration**

**53**

Connecting a modem using the CLI	53
Connecting a modem using the NNCLI	56
Connecting a VT-100 terminal or PC for local access	58
Setting system date and time using the CLI	59
Procedure job aid: config setdate command sample output	59
Setting system date and time using the NNCLI	59
Procedure job aid: clock set command output	59
Changing passwords using the CLI	60
Changing passwords using the NNCLI	63
Configuring the system using the setup utility	65
Procedure job aid: Setup Utility prompt descriptions	66

---

## **Translation of safety messages**

**69**

Fan tray safety warning message	69
Preventing back injury warning statement	70
Preventing electrical shock warning statement	72
Preventing hand injury warning statement	73
Safety danger statement	74
Injury to eye warning statement	75
Safety practices and the hazards danger statement	77
Safety practices and the hazards danger statement	78
Preventing electric shock danger statement	80

---

# Regulatory Information and Safety Precautions

---

Read the information in this section to learn about regulatory conformities and compliances.

## International Regulatory Statements of Conformity

This is to certify that the Nortel 8000 Series chassis and components installed within the chassis were evaluated to the international regulatory standards for electromagnetic compliance (EMC) and safety and were found to have met the requirements for the following international standards:

- EMC—Electromagnetic Emissions—CISPR 22, Class A
- EMC—Electromagnetic Immunity—CISPR 24
- Electrical Safety—IEC 60950, with CB member national deviations

Further, the equipment has been certified as compliant with the national standards as detailed in the following sections.

## National Electromagnetic Compliance (EMC) Statements of Compliance

### FCC Statement (USA only)

This equipment has been tested and found to comply with the limits for a Class A digital device, pursuant to Part 15 of the Federal Communications Commission (FCC) rules. These limits are designed to provide reasonable protection against harmful interference when the equipment is operated in a commercial environment. This equipment generates, uses, and can radiate radio frequency energy. If it is not installed and used in accordance with the instruction manual, it may cause harmful interference to radio communications. Operation of this equipment in a residential area is likely to cause harmful interference, in which case users will be required to take whatever measures may be necessary to correct the interference at their own expense.

### **ICES Statement (Canada only)**

#### **Canadian Department of Communications Radio Interference Regulations**

This digital apparatus (8000 Series chassis and installed components) does not exceed the Class A limits for radio-noise emissions from digital apparatus as set out in the Radio Interference Regulations of the Canadian Department of Communications.

#### **Règlement sur le brouillage radioélectrique du ministère des Communications**

Cet appareil numérique (8000 Series chassis) respecte les limites de bruits radioélectriques visant les appareils numériques de classe A prescrites dans le Règlement sur le brouillage radioélectrique du ministère des Communications du Canada.

### **CE Marking Statement (Europe only)**

#### **EN 55 022 Statements**

This is to certify that the Nortel 8000 Series chassis and components installed within the chassis are shielded against the generation of radio interference in accordance with the application of Council Directive 2004/108/EC. Conformity is declared by the application of EN 55 022 Class A (CISPR 22).



#### **CAUTION**

This device is a Class A product. Operation of this equipment in a residential area is likely to cause harmful interference, in which case users are required to take appropriate measures necessary to correct the interference at their own expense.

#### **EN 55 024 Statement**

This is to certify that the Nortel 8000 Series chassis is shielded against the susceptibility to radio interference in accordance with the application of Council Directive 2004/108/EC. Conformity is declared by the application of EN 55 024 (CISPR 24).

#### **EN 300386 Statement**

The Ethernet Routing Switch 8000 Series chassis complies with the requirements of EN 300386 V1.3.3 for emissions and for immunity for a Class A device intended for use in either Telecommunications centre or locations other than telecommunications centres given the performance criteria as specified by the manufacturer.

#### **EC Declaration of Conformity**

This product conforms to the provisions of the R&TTE Directive 1999/5/EC.

## European Union and European Free Trade Association (EFTA) Notice

 All products labeled with the CE marking comply with R&TTE Directive (1999/5/EEC) which includes the Electromagnetic Compliance (EMC) Directive (2004/108/EC) and the Low Voltage Directive (2006/95/EC) issued by the Commission of the European Community.

Compliance with these directives implies conformity to the following European Norms (ENs). The equivalent international standards are listed in parenthesis.

- EN 55022 (CISPR 22)–Electromagnetic Interference
- EN 55024 (IEC 61000-4-2, -3, -4, -5, -6, -8, -11)–Electromagnetic Immunity
- EN 61000-3-2 (IEC 61000-3-2)–Power Line Harmonics
- EN 61000-3-3 (IEC 61000-3-3)–Power Line Flicker

## VCCI Statement (Japan/Nippon only)

This is a Class A product based on the standard of the Voluntary Control Council for Interference (VCCI) for information technology equipment. If this equipment is used in a domestic environment, radio disturbance may arise. When such trouble occurs, the user may be required to take corrective actions.

この装置は、情報処理装置等電波障害自主規制協議会（VCCI）の基準に基づくクラスA情報技術装置です。この装置を家庭環境で使用すると電波妨害を引き起こすことがあります。この場合には使用者が適切な対策を講ずるよう要求されることがあります。

## BSMI Statement for 8010, 8006 and 8003 Chassis (Taiwan only)

This is a Class A product based on the standard of the Bureau of Standards, Metrology and Inspection (BSMI) CNS 13438, Class A.

警告使用者：

這是甲類的資訊產品，在居住的環境中使用時，可能會造成射頻干擾，在這種情況下，使用者會被要求採取某些適當的對策。

## MIC Notice for 8010, 8006, 8003 Chassis (Republic of Korea only)

This device has been approved for use in Business applications only per the Class A requirements of the Republic of Korea Ministry of Information and Communications (MIC). This device may not be sold for use in a non-business application.



## National Safety Statements of Compliance CE Marking Statement (Europe only)

### EN 60 950 Statement

This is to certify that the Nortel 8000 Series chassis and components installed within the chassis are in compliance with the requirements of EN 60 950 in accordance with the Low Voltage Directive. Additional national differences for all European Union countries have been evaluated for compliance. Some components installed within the 8000 Series chassis may use a nickel-metal hydride (NiMH) and/or lithium-ion battery. The NiMH and lithium-ion batteries are long-life batteries, and it is very possible that you will never need to replace them. However, should you need to replace them, refer to the individual component manual for directions on replacement and disposal of the battery.

### NOM Statement 8010, 8006, and 8003 Chassis (Mexico only)

The following information is provided on the devices described in this document in compliance with the safety requirements of the Norma Oficial Mexicana (NOM):

Exporter: Nortel Networks, Inc.  
4655 Great America Parkway  
Santa Clara CA 95054 USA

Importer: Nortel Networks de México, S.A. de C.V.  
Avenida Insurgentes Sur #1605  
Piso 30, Oficina  
Col. San Jose Insurgentes  
Deleg-Benito Juarez

---

Nortel Ethernet Routing Switch 8600  
Quick Start  
NN46205-310 02.01 Standard  
30 May 2008



México D.F. 03900

Tel: 52 5 480 2100

Fax: 52 5 480 2199

Input: Model 8003AC:  
100-240 VAC, 50-60 Hz, 9 A maximum for each power supply

Model 8004AC:  
100-240 VAC, 50-60 Hz, 12-6 A maximum for each power supply

Model 8005AC:  
100-120 VAC, 50-60 Hz, 16 A maximum for each power supply  
200-240 VAC, 50-60 Hz, 8.5 A maximum for each power supply

Model 8005DI AC:  
100-120 VAC, 50-60 Hz, 16 A maximum for each power supply  
200-240 VAC, 50-60 Hz, 9.3 A maximum for each power supply

Model 8004DC:  
48-60 VDC, 29-23 A

Model 8005DC:  
48-60 VDC, 42-34 A

### **Información NOM (unicamente para México)**

La información siguiente se proporciona en el dispositivo o en los dispositivos descritos en este documento, en cumplimiento con los requisitos de la Norma Oficial Mexicana (NOM):

Exportador: Nortel Networks, Inc.  
4655 Great America Parkway  
Santa Clara, CA 95054 USA

Importador: Nortel Networks de México, S.A. de C.V.  
Avenida Insurgentes Sur #1605  
Piso 30, Oficina

---

Nortel Ethernet Routing Switch 8600  
Quick Start  
NN46205-310 02.01 Standard  
30 May 2008

Col. San Jose Insurgentes

Deleg-Benito Juarez

México D.F. 03900

Tel: 52 5 480 2100

Fax: 52 5 480 2199

Embarcar a: Model 8003AC:

100-240 VCA, 50-60 Hz, 9 A max. por fuente de poder

Model 8004AC:

100-240 VCA, 50-60 Hz, 12-6 A max. por fuente de poder

Model 8005AC:

100-120 VCA, 50-60 Hz, 16 A max. por fuente de poder

200-240 VCA, 50-60 Hz, 9.5 A max. por fuente de poder

Model 8005DI AC:

100-120 VCA, 50-60 Hz, 16 A max por fuente de poder

200-240 VCA, 50-60 Hz, 9.3 A max por fuente de poder

Model 8004DC:

-48 VCD, 29 A

Model 8005DC:

-48 VCD, 42 A

### Denan Statement (Japan/Nippon only)



#### 警告

本製品を安全にご使用頂くため、以下のことにご注意ください。

- 接続ケーブル、電源コード、ACアダプタなどの部品は、必ず製品に同梱されております添付品または指定品をご使用ください。添付品・指定品以外の部品をご使用になると故障や動作不良、火災の原因となることがあります。
  - 同梱されております付属の電源コードを他の機器には使用しないでください。上記注意事項を守らないと、死亡や大怪我など人身事故の原因となることがあります。
- 

---

Nortel Ethernet Routing Switch 8600  
Quick Start  
NN46205-310 02.01 Standard  
30 May 2008

## Safety Messages

This section describes the different precautionary notices used in this document. This section also contains precautionary notices that you must read for safe operation of the Nortel Ethernet Routing Switch 8600.

### Notices

Notice paragraphs alert you about issues that require your attention. The following sections describe the types of notices. For a list of safety messages used in this guide and their translations, see "Translations of safety messages".

#### Attention Notice

##### **ATTENTION**

An attention notice provides important information regarding the installation and operation of Nortel products.

#### Caution ESD Notice



##### **CAUTION ESD**

ESD notices provide information about how to avoid discharge of static electricity and subsequent damage to Nortel products.



##### **CAUTION ESD (décharge électrostatique)**

La mention ESD fournit des informations sur les moyens de prévenir une décharge électrostatique et d'éviter d'endommager les produits Nortel.



##### **CAUTION ACHTUNG ESD**

ESD-Hinweise bieten Information dazu, wie man die Entladung von statischer Elektrizität und Folgeschäden an Nortel-Produkten verhindert.



##### **CAUTION PRECAUCIÓN ESD (Descarga electrostática)**

El aviso de ESD brinda información acerca de cómo evitar una descarga de electricidad estática y el daño posterior a los productos Nortel.



##### **CAUTION CUIDADO ESD**

Os avisos do ESD oferecem informações sobre como evitar descarga de eletricidade estática e os conseqüentes danos aos produtos da Nortel.



**CAUTION  
ATTENZIONE ESD**

Le indicazioni ESD forniscono informazioni per evitare scariche di elettricità statica e i danni correlati per i prodotti Nortel.

**Caution Notice**



**CAUTION**

Caution notices provide information about how to avoid possible service disruption or damage to Nortel products.



**CAUTION  
ATTENTION**

La mention Attention fournit des informations sur les moyens de prévenir une perturbation possible du service et d'éviter d'endommager les produits Nortel.



**CAUTION  
ACHTUNG**

Achtungshinweise bieten Informationen dazu, wie man mögliche Dienstunterbrechungen oder Schäden an Nortel-Produkten verhindert.



**CAUTION  
PRECAUCIÓN**

Los avisos de Precaución brindan información acerca de cómo evitar posibles interrupciones del servicio o el daño a los productos Nortel.



**CAUTION  
CUIDADO**

Os avisos de cuidado oferecem informações sobre como evitar possíveis interrupções do serviço ou danos aos produtos da Nortel.



**CAUTION  
ATTENZIONE**

Le indicazioni di attenzione forniscono informazioni per evitare possibili interruzioni del servizio o danni ai prodotti Nortel.

**Warning Notice**



**WARNING**

Warning notices provide information about how to avoid personal injury when working with Nortel products.



**WARNING  
AVERTISSEMENT**

La mention Avertissement fournit des informations sur les moyens de prévenir les risques de blessure lors de la manipulation de produits Nortel.



**WARNING  
WARNUNG**

Warnhinweise bieten Informationen dazu, wie man Personenschäden bei der Arbeit mit Nortel-Produkten verhindert.



**WARNING  
ADVERTENCIA**

Los avisos de Advertencia brindan información acerca de cómo prevenir las lesiones a personas al trabajar con productos Nortel.



**WARNING  
AVISO**

Os avisos oferecem informações sobre como evitar ferimentos ao trabalhar com os produtos da Nortel.



**WARNING  
AVVISO**

Le indicazioni di avviso forniscono informazioni per evitare danni alle persone durante l'utilizzo dei prodotti Nortel.

**Danger High Voltage Notice**



**DANGER**

Danger—High Voltage notices provide information about how to avoid a situation or condition that can cause serious personal injury or death from high voltage or electric shock.



**DANGER**

La mention Danger—Tension élevée fournit des informations sur les moyens de prévenir une situation ou une condition qui pourrait entraîner un risque de blessure grave ou mortelle à la suite d'une tension élevée ou d'un choc électrique.



**DANGER  
GEFAHR**

Hinweise mit Vorsicht – Hochspannung“ bieten Informationen dazu, wie man Situationen oder Umstände verhindert, die zu schweren Personenschäden oder Tod durch Hochspannung oder Stromschlag führen können.



**DANGER  
PELIGRO**

Los avisos de Peligro-Alto voltaje brindan información acerca de cómo evitar una situación o condición que cause graves lesiones a personas o la muerte, a causa de una electrocución o de una descarga de alto voltaje.



**DANGER  
PERIGO**

Avisos de Perigo—Alta Tensão oferecem informações sobre como evitar uma situação ou condição que possa causar graves ferimentos ou morte devido a alta tensão ou choques elétricos.



**DANGER  
PERICOLO**

Le indicazioni Pericolo—Alta tensione forniscono informazioni per evitare situazioni o condizioni che potrebbero causare gravi danni alle persone o il decesso a causa dell'alta tensione o di scosse elettriche.

**Danger Notice**



**DANGER**

Danger notices provide information about how to avoid a situation or condition that can cause serious personal injury or death.



**DANGER**

La mention Danger fournit des informations sur les moyens de prévenir une situation ou une condition qui pourrait entraîner un risque de blessure grave ou mortelle.



**DANGER  
GEFAHR**

Gefahrenhinweise stellen Informationen darüber bereit, wie man Situationen oder Umständen verhindert, die zu schweren Personenschäden oder Tod führen können.



**DANGER  
PELIGRO**

Los avisos de Peligro brindan información acerca de cómo evitar una situación o condición que pueda causar lesiones personales graves o la muerte.



**DANGER  
PERIGO**

Avisos de perigo oferecem informações sobre como evitar uma situação ou condição que possa causar graves ferimentos ou morte.



**DANGER**  
**PERICOLO**

Le indicazioni di pericolo forniscono informazioni per evitare situazioni o condizioni che potrebbero causare gravi danni alle persone o il decesso.

---

Nortel Ethernet Routing Switch 8600  
Quick Start  
NN46205-310 02.01 Standard  
30 May 2008



---

## Software license

---

This section contains the Nortel Networks software license.

### **Nortel Networks Inc. software license agreement**

This Software License Agreement ("License Agreement") is between you, the end-user ("Customer") and Nortel Networks Corporation and its subsidiaries and affiliates ("Nortel Networks"). PLEASE READ THE FOLLOWING CAREFULLY. YOU MUST ACCEPT THESE LICENSE TERMS IN ORDER TO DOWNLOAD AND/OR USE THE SOFTWARE. USE OF THE SOFTWARE CONSTITUTES YOUR ACCEPTANCE OF THIS LICENSE AGREEMENT. If you do not accept these terms and conditions, return the Software, unused and in the original shipping container, within 30 days of purchase to obtain a credit for the full purchase price.

"Software" is owned or licensed by Nortel Networks, its parent or one of its subsidiaries or affiliates, and is copyrighted and licensed, not sold. Software consists of machine-readable instructions, its components, data, audio-visual content (such as images, text, recordings or pictures) and related licensed materials including all whole or partial copies. Nortel Networks grants you a license to use the Software only in the country where you acquired the Software. You obtain no rights other than those granted to you under this License Agreement. You are responsible for the selection of the Software and for the installation of, use of, and results obtained from the Software.

**1. Licensed Use of Software.** Nortel Networks grants Customer a nonexclusive license to use a copy of the Software on only one machine at any one time or to the extent of the activation or authorized usage level, whichever is applicable. To the extent Software is furnished for use with designated hardware or Customer furnished equipment ("CFE"), Customer is granted a nonexclusive license to use Software only on such hardware or CFE, as applicable. Software contains trade secrets and Customer agrees to treat Software as confidential information using the same care and discretion Customer uses with its own similar information that it does not wish to disclose, publish or disseminate. Customer will ensure that anyone who uses the Software does so only in compliance with the terms

of this Agreement. Customer shall not a) use, copy, modify, transfer or distribute the Software except as expressly authorized; b) reverse assemble, reverse compile, reverse engineer or otherwise translate the Software; c) create derivative works or modifications unless expressly authorized; or d) sublicense, rent or lease the Software. Licensors of intellectual property to Nortel Networks are beneficiaries of this provision. Upon termination or breach of the license by Customer or in the event designated hardware or CFE is no longer in use, Customer will promptly return the Software to Nortel Networks or certify its destruction. Nortel Networks may audit by remote polling or other reasonable means to determine Customer's Software activation or usage levels. If suppliers of third party software included in Software require Nortel Networks to include additional or different terms, Customer agrees to abide by such terms provided by Nortel Networks with respect to such third party software.

**2. Warranty.** Except as may be otherwise expressly agreed to in writing between Nortel Networks and Customer, Software is provided "AS IS" without any warranties (conditions) of any kind. NORTEL NETWORKS DISCLAIMS ALL WARRANTIES (CONDITIONS) FOR THE SOFTWARE, EITHER EXPRESS OR IMPLIED, INCLUDING, BUT NOT LIMITED TO THE IMPLIED WARRANTIES OF MERCHANTABILITY AND FITNESS FOR A PARTICULAR PURPOSE AND ANY WARRANTY OF NON-INFRINGEMENT. Nortel Networks is not obligated to provide support of any kind for the Software. Some jurisdictions do not allow exclusion of implied warranties, and, in such event, the above exclusions may not apply.

**3. Limitation of Remedies.** IN NO EVENT SHALL NORTEL NETWORKS OR ITS AGENTS OR SUPPLIERS BE LIABLE FOR ANY OF THE FOLLOWING: a) DAMAGES BASED ON ANY THIRD PARTY CLAIM; b) LOSS OF, OR DAMAGE TO, CUSTOMER'S RECORDS, FILES OR DATA; OR c) DIRECT, INDIRECT, SPECIAL, INCIDENTAL, PUNITIVE, OR CONSEQUENTIAL DAMAGES (INCLUDING LOST PROFITS OR SAVINGS), WHETHER IN CONTRACT, TORT OR OTHERWISE (INCLUDING NEGLIGENCE) ARISING OUT OF YOUR USE OF THE SOFTWARE, EVEN IF NORTEL NETWORKS, ITS AGENTS OR SUPPLIERS HAVE BEEN ADVISED OF THEIR POSSIBILITY. The forgoing limitations of remedies also apply to any developer and/or supplier of the Software. Such developer and/or supplier is an intended beneficiary of this Section. Some jurisdictions do not allow these limitations or exclusions and, in such event, they may not apply.

#### **4. General**

1. If Customer is the United States Government, the following paragraph shall apply: All Nortel Networks Software available under this License Agreement is commercial computer software and commercial computer

software documentation and, in the event Software is licensed for or on behalf of the United States Government, the respective rights to the software and software documentation are governed by Nortel Networks standard commercial license in accordance with U.S. Federal Regulations at 48 C.F.R. Sections 12.212 (for non-DoD entities) and 48 C.F.R. 227.7202 (for DoD entities).

2. Customer may terminate the license at any time. Nortel Networks may terminate the license if Customer fails to comply with the terms and conditions of this license. In either event, upon termination, Customer must either return the Software to Nortel Networks or certify its destruction.
3. Customer is responsible for payment of any taxes, including personal property taxes, resulting from Customer's use of the Software. Customer agrees to comply with all applicable laws including all applicable export and import laws and regulations.
4. Neither party may bring an action, regardless of form, more than two years after the cause of the action arose.
5. The terms and conditions of this License Agreement form the complete and exclusive agreement between Customer and Nortel Networks.
6. This License Agreement is governed by the laws of the country in which Customer acquires the Software. If the Software is acquired in the United States, then this License Agreement is governed by the laws of the state of New York.

---

Nortel Ethernet Routing Switch 8600  
Quick Start  
NN46205-310 02.01 Standard  
30 May 2008

---

## New in this release

---

The following sections detail what's new in *Nortel Ethernet Routing Switch 8600 Quick Start*, (NN46205-310) for Release 5.0.

- [“Features” \(page 21\)](#)
- [“Other changes” \(page 21\)](#)

### Features

See the following sections for information about changes that are feature related:

- [“Nortel Command Line Interface” \(page 21\)](#)

#### **Nortel Command Line Interface**

The Nortel Ethernet Routing Switch 8600 uses the Nortel Networks Command Line Interface (NNCLI). This document provides configuration instructions for existing features using the NNCLI.

### Other changes

See the following sections for information about the changes that are not feature related:

- [“Connecting the modem using the CLI” \(page 22\)](#)
- [“Connecting the modem using the NNCLI” \(page 22\)](#)
- [“Setting the system date and time using the CLI” \(page 22\)](#)
- [“Setting the system date and time using the NNCLI” \(page 22\)](#)
- [“Changing passwords using the CLI” \(page 22\)](#)
- [“Changing passwords using the NNCLI” \(page 22\)](#)

## Connecting the modem using the CLI

This section describes how to connect a modem to the modem port on an SF/CPU module using the CLI command. You can access the CLI through a modem connection to the Ethernet Routing Switch 8690SF, 8691SF/CPU, or 8692SF/CPU modules.

For more information, see [“Connecting a modem using the CLI” \(page 53\)](#).

## Connecting the modem using the NNCLI

This section describes how to connect a modem to the modem port on an SF/CPU module using the NNCLI command. You can access the NNCLI through a modem connection to the Ethernet Routing Switch 8690SF, 8691SF/CPU, or 8692SF/CPU modules.

For more information, see [“Connecting a modem using the NNCLI” \(page 56\)](#).

## Setting the system date and time using the CLI

This section describes the instructions to set the system date and time using the CLI.

For more information, see [“Setting system date and time using the CLI” \(page 59\)](#).

## Setting the system date and time using the NNCLI

This section describes the instructions to set the system date and time using the NNCLI.

For more information, see [“Setting system date and time using the NNCLI” \(page 59\)](#).

## Changing passwords using the CLI

This section describes the instructions to set new passwords for each access level, or change the logon password for the different switch access using the CLI.

For more information, see [“Connecting a modem using the CLI” \(page 53\)](#)

## Changing passwords using the NNCLI

This section describes the instructions to set new passwords for each access level, or change the logon password for the different switch access using the NNCLI.

For more information, see [“Changing passwords using the NNCLI” \(page 63\)](#).

# Introduction

---

The *Nortel Ethernet Routing Switch 8600 Quick Start, NN46205-310* provides basic instructions about installing the hardware and performing basic configuration of the Ethernet Routing Switch 8010, 8006, 8003, and 8010co chassis and software.

## Navigation

- [“Installation preparation” \(page 25\)](#)
- [“Installation” \(page 31\)](#)
- [“Configuration” \(page 53\)](#)

---

Nortel Ethernet Routing Switch 8600  
Quick Start  
NN46205-310 02.01 Standard  
30 May 2008



---

# Installation preparation

---

This section provides basic information about the Ethernet Routing Switch 8600 slots. It also include a checklist of the shipped accessories.

## Navigation

- [“Ethernet Routing Switch 8600 slots ” \(page 25\)](#)
- [“DC power supply accessories” \(page 26\)](#)
- [“Safety precautions” \(page 27\)](#)

## Ethernet Routing Switch 8600 slots

The Ethernet Routing Switch 8010co chassis provides eight slots for installing Ethernet Routing Switch 8600 interface modules and two slots for installing the Ethernet Routing Switch 8691SF/CPU and 8692SF/CPU (switch fabric) modules. Slots are numbered from left to right. Install Ethernet Routing Switch 8600 interface modules in slots 1 to 4 and 7 to 10. Slots 5 and 6 are reserved for Ethernet Routing Switch 8600 Series SF/CPU modules.

The 8010 chassis provides eight slots for installing Ethernet Routing Switch 8600 interface modules and two slots for installing Ethernet Routing Switch 8691SF/CPU or 8692SF/CPU modules. Slots are numbered from top to bottom. Install Ethernet Routing Switch 8600 interface modules in slots 1 to 4 and 7 to 10. Slots 5 and 6 are reserved for Ethernet Routing Switch 8600 SF/CPU modules.



The 8006 chassis provides four slots for installing Ethernet Routing Switch 8600 interface modules and two slots for installing Ethernet Routing Switch 8691SF/CPU or 8692SF/CPU modules. Slots are numbered from top to bottom. Install Ethernet Routing Switch 8600 interface modules in slots 1 to 4. Slots 5 and 6 are reserved for Ethernet Routing Switch 8600 SF/CPU modules.

The 8003 chassis provides two slots for installing Ethernet Routing Switch 8600 interface modules and one slot for installing an Ethernet Routing Switch 8691/CPU Module. Slots are numbered from top to bottom.

### DC power supply accessories

The DC power supply shipment contains hardware accessories. Use the following checklist to verify the contents of the 8004DC shipping container.

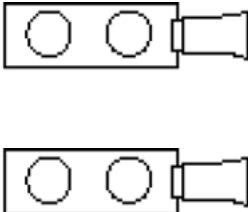
**Table 1**  
**8004DC power supply shipping accessories**

Check	Accessory		Use to
	Two 2-hole crimp lug terminals with attached tubing (8004)		Connect the positive and negative power inputs
	One 1-hole crimp lug terminal with attached tubing		Connect the ground stud
	5 nuts		Connect all leads
	5 lock washers		Connect all leads
	1 washer		Connect the ground stud

Use the following checklist to verify the contents of the 8005DC shipping container.

**Table 2**  
**8005DC power supply shipping accessories**

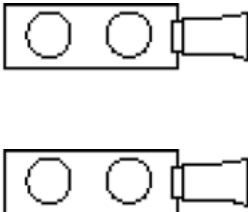
Check	Accessory		Use to
	Three 2-hole crimp lug terminals with attached tubing		Connect the positive and negative power inputs

Check	Accessory		Use to
			
	6 nuts		Connect all leads
	6 lock washers		Connect all leads
	2 washers		Connect the ground stud

## Safety precautions

This section describes the safety precautions which are vital for handling and installing the Ethernet Routing Switch 8600.

### Safety precautions navigation

- [“Personal safety” \(page 27\)](#)
- [“Module safety” \(page 28\)](#)
- [“Cable and connector safety” \(page 28\)](#)
- [“Electrostatic discharge safety” \(page 29\)](#)

### Personal safety

For your safety, review the following personal safety warnings before working with the Ethernet Routing Switch 8600.



**DANGER**  
**Risk of injury by fan blades**  
 When removing the fan module, do not put your hands into the opening because of the spinning fan blades in the adjacent fan modules.



**WARNING**  
**Risk of personal injury**  
 Grasp the fan tray at the middle of the front panel, and be careful to keep your fingers out of the fan blades.



**DANGER**  
**Risk of injury by electric shock**  
 The electrical connector at the rear of the slot poses a risk of electrical shock.



**WARNING**

**Risk of eye injury by laser**

Fiber optic equipment can emit laser or infrared light that can injure your eyes. Never look into an optical fiber or connector port. Always assume that fiber optic cables are connected to a light source.

**Module safety**

Use the following general practices to prevent the equipment damage when working with the Ethernet Routing Switch 8600.

- Always wear an antistatic wrist strap that is connected to an Electrostatic discharge (ESD) grounding jack when handling modules.
- Always set modules on appropriate antistatic material.
- Handle modules using the faceplate. Do not touch pins or electrical connections.
- Do not leave slots open. Fill all the slots with modules, or use slot covers to maintain safety compliance, proper cooling, and EMI containment in the chassis.
- Ensure your environment meets the requirements for temperature, humidity, and cleanliness.
- Replace the 8010co chassis air filter regularly (approximately every three months) to maintain proper cooling and airflow. For instructions to replace the 8010co chassis air filter, see *Nortel Ethernet Routing Switch 8600 Routine Maintenance, NN46205-312*.
- Do not overtighten thumb screws or lug nuts. Tighten screws and nuts until snug plus a quarter turn. If you use a power tool to tighten screws, use a low torque setting (2 to 3 inches per pound [in./lb]).

**Cable and connector safety**

Use the following instructions to safeguard cables and connectors while working with the Ethernet Routing Switch 8600.

- Support cables to prevent stress on connectors. If the Ethernet Routing Switch 8600 has a high cable-density configuration, install additional cable-management equipment.
- Do not exceed the bend radius recommended for the cable type installed.
- Fiber optic cables and connectors require special care.

- Protect connectors with rubber safety plugs when cables are not inserted.
- Follow appropriate fiber-cleaning procedures to install or replace cables.
- Do not exceed the bend radius recommended for fiber optic cables. The acceptable bend radius for fiber optic cable is ten times its diameter, or 2.5 to 5 cm (1 to 2 in.). Anything less than the recommendation can cause a loss of integrity during data transmission. It is difficult to diagnose loss of integrity because of incorrect bend radius.

### **Electrostatic discharge safety**

Electrostatic discharge (ESD) is the transfer of charge between objects at different electrical potentials. ESD can change the electrical characteristics and degrade or destroy a semiconductor device. ESD can also disrupt the normal operation of an electronic system by causing equipment malfunction or failure.

To dissipate or neutralize electrostatic charges, use proper grounding and conductive or dissipative materials.



#### **CAUTION**

##### **Risk of equipment damage**

To prevent damage from electrostatic discharge, always wear an antistatic wrist strap connected to an electrostatic discharge (ESD) jack.

Proper antistatic packaging effectively shields products from electrostatic charges and reduces the charge generation caused by product movement within the container.



---

# Installation

---

This chapter contains installation instructions for the Ethernet Routing Switch 8000 series chassis.

## Navigation

- “Unpacking the chassis” (page 32)
- “Removing a power filler panel” (page 33)
- “Installing an Ethernet Routing Switch 8003, 8006, or 8010 chassis into a rack” (page 34)
- “Installing the 8010co chassis in a 19-inch two-post rack” (page 36)
- “Installing the 8003, 8006, and 8010 chassis cable guides” (page 37)
- “Installing the top cable-management bracket” (page 38)
- “Installing the side cable-management brackets” (page 39)
- “Grounding the 8010co chassis” (page 40)
- “Installing a module” (page 41)
- “Installing AC power modules” (page 43)
- “Installing DC power modules” (page 44)
- “Installing a breaker interface panel” (page 49)
- “Installing a PCMCIA software card” (page 49)
- “Starting the system” (page 49)
- “Verifying a successful installation” (page 51)

## Unpacking the chassis

Unpack the shipping container to ensure the chassis and all accessories are included and undamaged.



**Procedure steps**

- | Step | Action   |
|------|--|
| 1    | Remove the equipment from the shipping container and place the chassis on antistatic material. |
| 2    | Check all items for damage.  |

**ATTENTION**  
If the equipment is damaged, contact your Nortel sales representative.

- |   |   |
|---|---|
| 3 | Use the following chassis shipping accessories checklist to verify that the shipping container includes all contents. |
|---|---|

Check	Accessory	Use to
	Bracket kit: two rack-mounting brackets and Phillips-head screws.	Support the chassis in an equipment rack.
	Screw package	Mount the chassis in an equipment rack.
	Side cable-management bracket: two brackets for the 8010 chassis and one bracket for the 8006 and 8003 chassis	Manage network interface cables.
	Rubber footpads	Keep the chassis from slipping when mounting on a flat surface.
	Console cable with built-in adapter.	Connect an optional management console to the chassis. Each cable end has a female DB9 and a DB25 connector.
	Cable guide	Keep cable clusters fastened and out of the way, but accessible for maintenance.

--End--

## Removing a power filler panel

A power filler panel maintains the proper cooling airflow in the Ethernet Routing Switch 8600 chassis. You must remove the power filler panel from the power bay when you install a power supply in a bay for the first time

**Procedure steps**

Step	Action
1	Use a Phillips screwdriver to loosen the two screws that fasten the filler panel to the chassis.
2	Pull the filler panel away from the slot as shown in the following figure.

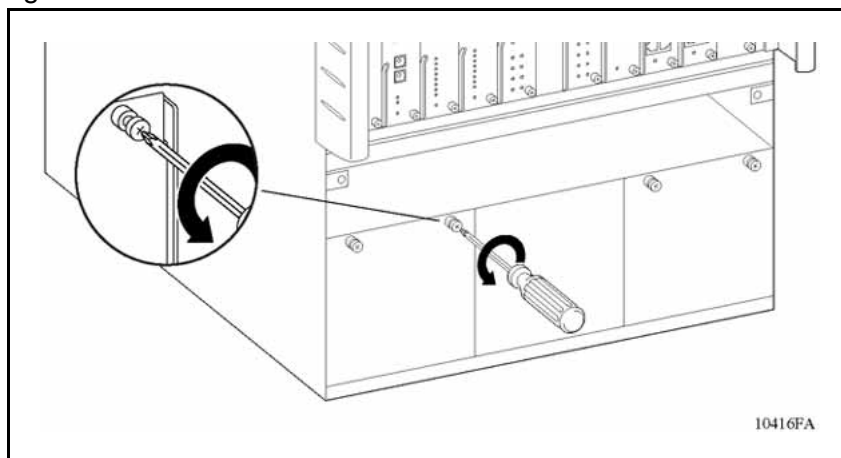

--End--

## Installing an Ethernet Routing Switch 8003, 8006, or 8010 chassis into a rack

Install an Ethernet Routing Switch 8003, 8006, or 8010 chassis in a standard equipment rack (19-inch).

### Prerequisites for installing an Ethernet Routing Switch 8003, 8006, or 8010 chassis into a rack

- Remove any filler panels before you install the chassis to decrease the weight during installation.

**Procedure steps**

Step	Action
1	Hold each rack-mounting bracket to the sides of the chassis, and align the screw holes.

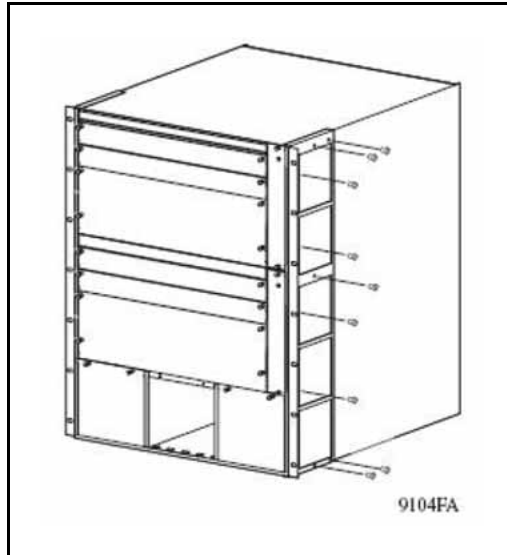

- 2 Attach the brackets to the chassis using the supplied Phillips-head screws.



**WARNING**

**Risk of personal injury**

It requires two people to lift a fully-loaded chassis. To prevent injury, keep your back straight and lift with your legs.

An Ethernet Routing Switch 8010 chassis weighs approximately 101 kg (225 lbs).

An Ethernet Routing Switch 8006 chassis weighs approximately 77 kg (170 lbs).

An Ethernet Routing Switch 8003 chassis weighs approximately 49.5 kg (110 lbs).

- 3 Hold the chassis in position and align the flanged end of each mounting rail with the two holes on each side of the vertical rack support.

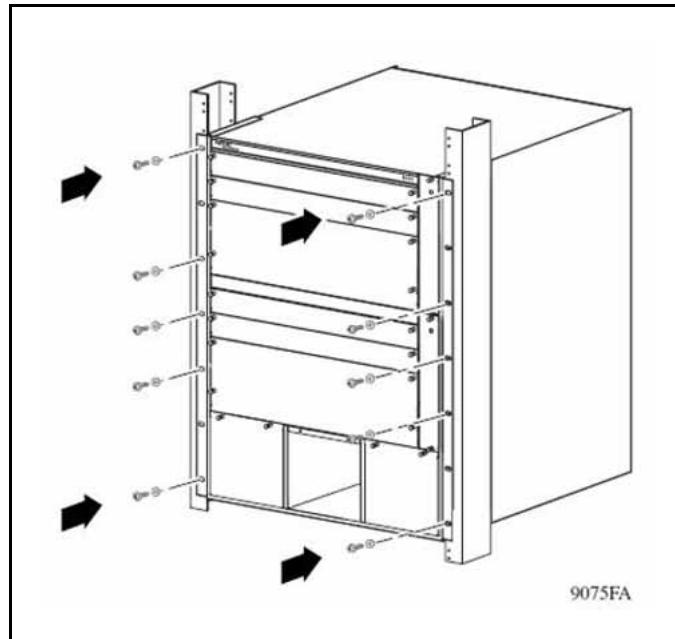

- 4 Insert and tighten the rack-mounting screws with a Phillips screwdriver.

--End--

## Installing the 8010co chassis in a 19-inch two-post rack

Install the 8010co chassis in a 19-inch two-post rack.

### Prerequisites

- Verify that you have the following tools and materials:
  - 12 Phillips-head screws
  - 1 Phillips screwdriver

### Procedure steps

Step	Action
1	Place the installation shelf at the bottom of the rack and inside the rails.
2	Hold the installation shelf in position and align the shelf mounting rail with the two holes on each side of the vertical rack support.
3	Insert a Phillips-head screw through each installation shelf mounting hole and into the corresponding hole in the rack.

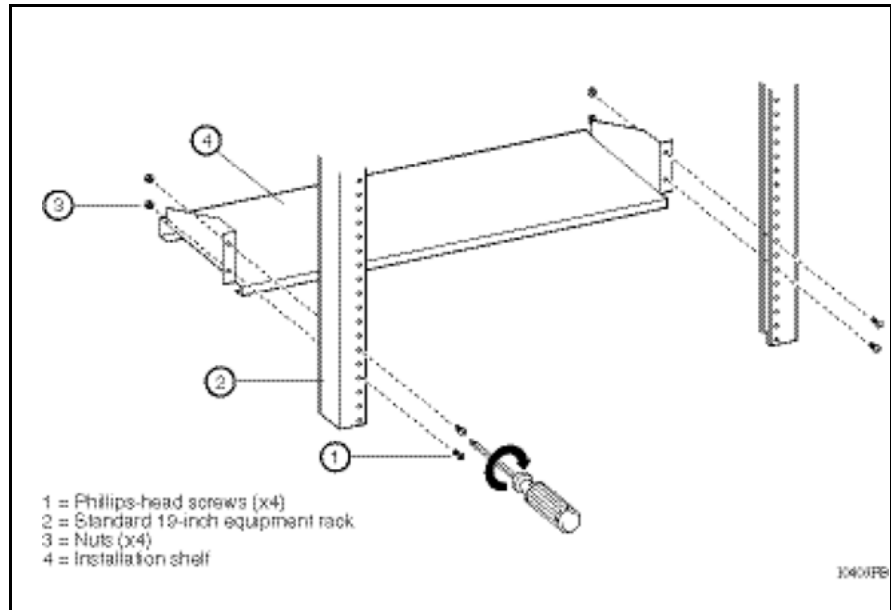

- 4 Add a hex nut to each screw and tighten using a hex wrench.
- 5 Tighten each screw using a Phillips-head screwdriver.
- 6 If the holes in the rack vertical supports require clip nuts, insert a clip nut into each of the 12 locations.
- 7 Lift the 8010co chassis onto the installation shelf.

**WARNING****Risk of personal injury**

It requires three people to lift the 8010co chassis. To make the chassis lighter, remove the modules and power supplies before you lift it.

- 8 Hold the 8010co chassis in position and align the flanged end of the chassis mounting rail with the six holes on each side of the vertical rack support.  
Make sure the hole pairs on each side of the vertical support match horizontally.
- 9 Tighten each screw using a Phillips-head screwdriver.

--End--

## Installing the 8003, 8006, and 8010 chassis cable guides

Install the 8003, 8006, and 8010 chassis cable guides to fasten the cable clusters and keep them out of the way.

**ATTENTION**

Ensure the cable clusters are accessible for maintenance.

**Procedure steps**

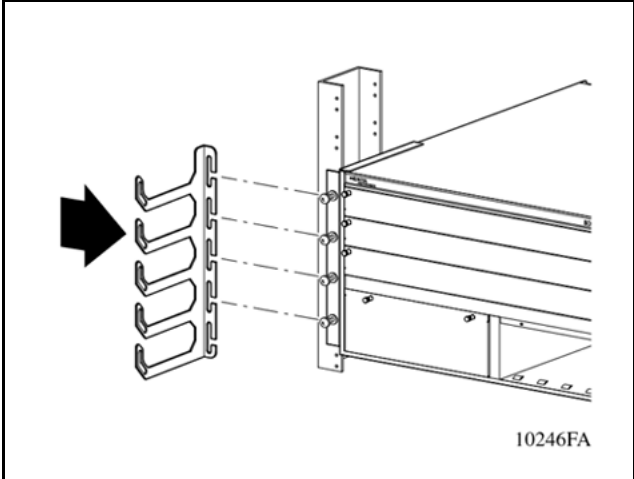
Step	Action
1	Loosen, but do not remove, the rack-mounting screws required to install a cable guide.
2	Slide the cable guide onto the loosened screws.
	
3	Tighten the screws to secure the cable guide to the chassis.
--End--	

## Installing the top cable-management bracket

Install the top cable-management bracket to the 8010co chassis.

### Procedure steps

Step	Action
1	Align the mounting retainers on the inside of the top cable-management bracket with the holes on the front of the chassis.
2	Push the sides of the top cable-management bracket into place.
3	Insert and tighten the eight screws using a Phillips screwdriver to secure the top cable-management bracket to the chassis.
--End--	

## Procedure job aid: Installing the cable-management brackets

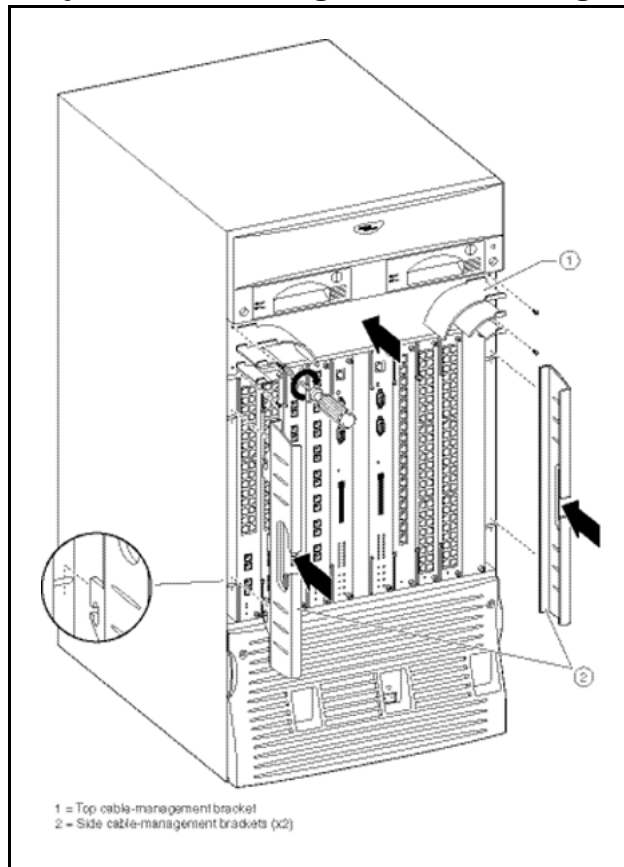

### Installing the side cable-management brackets

Install the side cable-management brackets to each side of the 8010co chassis.

#### Procedure steps

Step	Action
1	Align the slots on the side cable-management bracket with the rods in the chassis.
2	Push the bracket into place.

For more information, see [“Procedure job aid: Installing the cable-management brackets” \(page 39\)](#)

--End--

## Grounding the 8010co chassis

Ground the 8010co chassis to avoid electrical hazard and ensure optimal performance.

### ATTENTION

Nortel recommends grounding the 8010co chassis before you connect power cables or network cables to your switch.

### Prerequisites

- Verify that you have the following tools and materials:
  - One single-hole cable lug that fits over one of the grounding studs.
  - A nut and locking washer for the grounding stud
  - A 6-AWG grounding wire long enough to connect to the ground point
  - A 7/16-inch hex wrench to fasten the hardware in the correct order

### Procedure steps

Step	Action
1	<p>Locate the shelf grounding point on the rack.</p> <p>The rack grounding point is a grounding strip located on the back, base, top, or side.</p> <div style="border: 1px solid black; padding: 5px;"> <p><b>ATTENTION</b></p> <p>The rack grounding strip can look different than the one shown in <a href="#">"Procedure job aid: Grounding the 8010co chassis" (page 41)</a> the procedure job aid.</p> </div>
2	<p>Attach the lug ends of the chassis ground cables to the rack grounding strip using a 7/16-inch hex wrench to fasten the hardware in the correct order.</p> <p>For more information, see <a href="#">"Procedure job aid: Grounding the 8010co chassis" (page 41)</a>.</p>
<hr/> <p>--End--</p> <hr/>	



## Procedure job aid: Grounding the 8010co chassis

Figure 1

Location of ground studs on a 8010co chassis rear panel

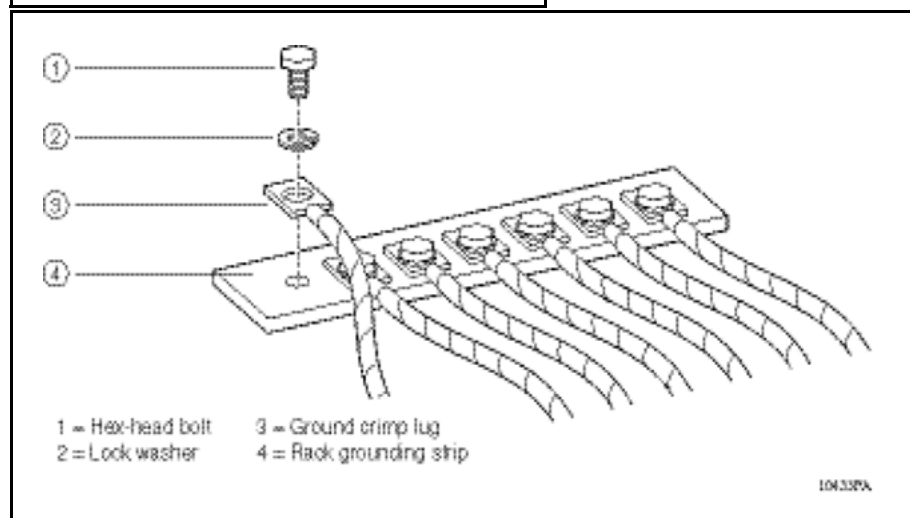
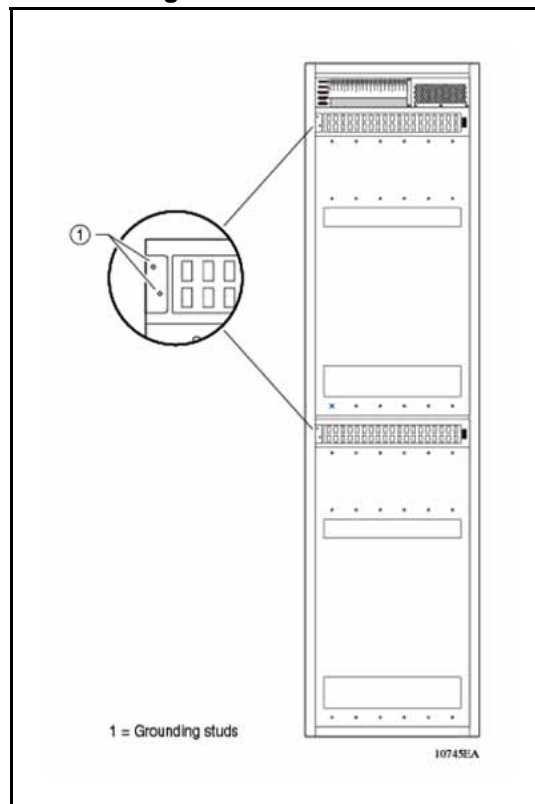

## Installing a module

Install Ethernet Routing Switch 8600 modules to provide communications interfaces for switching and routing operations.

**ATTENTION**

You can install an Ethernet Routing Switch 8600 module with the power on or off.

**Procedure steps**

Step	Action
1	Locate the slot where you want to install the module.
2	Remove the power filler panel. For instructions, see <a href="#">“Removing a power filler panel”</a> (page 33).
3	Extend the insert and extract levers away from the front of the module.
4	Slide the module into the slot, using the module guides, until the connector panel touches the chassis back panel.
5	Rotate the insert and extract levers to seat the module backplane connectors.
6	Tighten the two captive screws to secure the module to the chassis using a Phillips screwdriver. See <a href="#">“Procedure job aid: Installing a module”</a> (page 43) for installing a module in various chassis.
7	After you install the modules, you can connect console equipment and network cables.

---

--End--

---

## Procedure job aid: Installing a module

Figure 2

Installing a module in a 8010co chassis

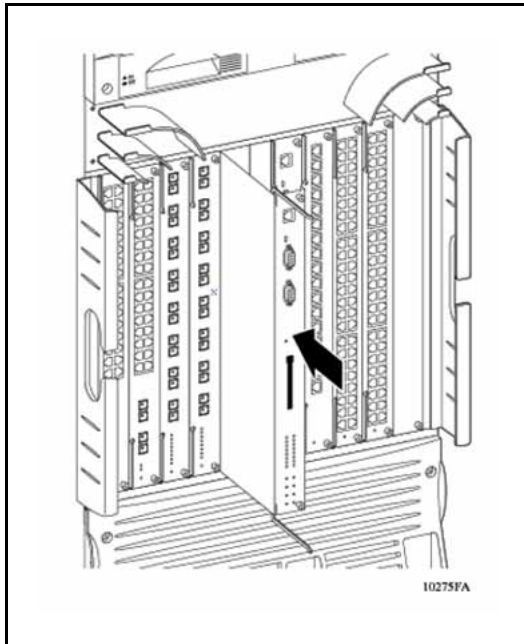
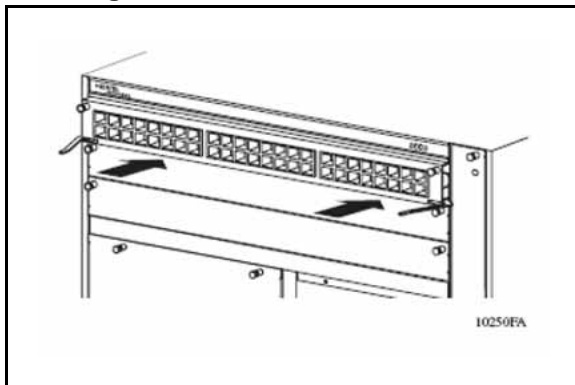

Figure 3

Installing a module in a 8003, 8006, and 8010 chassis



## Installing AC power modules

Install AC power modules in the left-most bay to supply AC power to the chassis.

### ATTENTION

The 8006, 8010, and 8010co chassis have three power supply bays that are numbered 1, 2, and 3 from left to right as viewed from the front of the chassis. The 8003 chassis has 2 power supply bays that are numbered 1 and 2 from left to right.

### Prerequisites

Ensure the filler panel or cover from the power bay is removed. To remove the filler panel, see “Removing a power filler panel” (page 33).

### Procedure steps

Step	Action
1	Grasp the handle of the new power supply and push the power supply firmly into the bay.
2	Tighten the retaining screws until the power supply is firmly seated.

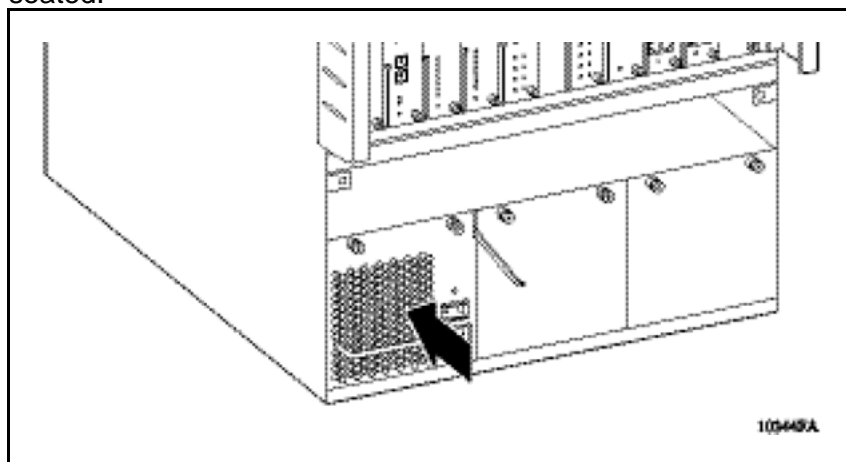

3	Connect the power cord to the power supply and to an AC power outlet that is connected to a circuit with no other equipment connections.
---	--

--End--

## Installing DC power modules

Install the DC power supply module in the leftmost bay to supply DC power to the chassis.

### ATTENTION

The 8006 and 8010 chassis have three power supply bays that are numbered 1, 2, and 3 from left to right as viewed from the front of the chassis.

### Prerequisites

- Verify that you have the following tools and materials:
  - Cable
  - Crimping tool for crimping the lugs onto the cable
  - Heat gun to shrink the tubing around the cable (optional)

- A 7/16-inch hex wrench
- Phillips screwdriver
- Ensure the filler panel or cover is removed from the power bay. To remove the filler panel, see [“Removing a power filler panel” \(page 33\)](#).

**ATTENTION**

Nortel does not supply the cables for connecting the DC power supply to the DC input power source. Select cables that comply with the electrical code of the country where you use the DC power supply.

**Procedure steps**

Step	Action
1	Make sure that the power switch is turned off.
2	Grasp the handle of the new power supply and push it partway into the bay, leaving the terminal block at the side of the power supply exposed.
3	Remove the screw that secures the plastic safety cover to the power supply using a Phillips screwdriver.
4	Remove the cover and set it aside.
5	Record the positions of the ground stud and of the positive and negative power inputs.

**ATTENTION**

Make sure the +DC cable is always connected to the positive terminal and that the -DC cable is always connected to the negative terminal.

**DANGER****Risk of injury by electric shock**

Make sure that the DC power source is off by switching off the circuit breaker or disconnecting at the remote end before you connect the terminal leads to the power supply.

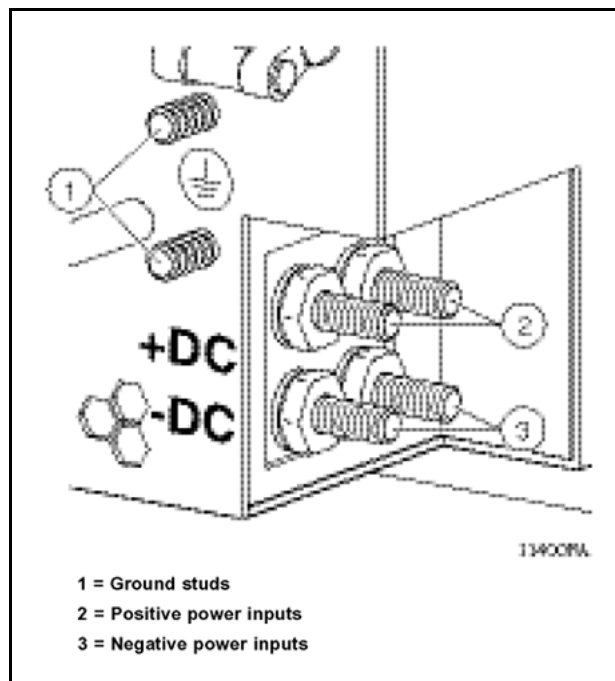
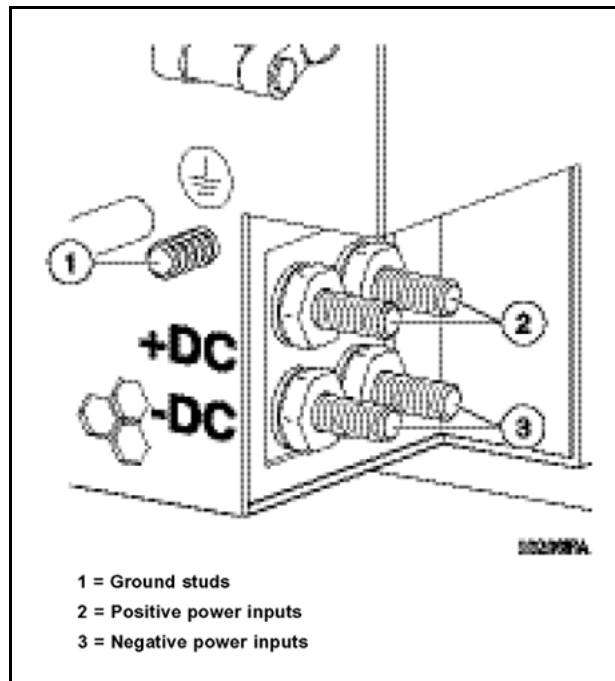

6 Attach the earth ground lead to the ground stud on the power supply. Use the washers in the following order:

- flat washer
- crimp lug
- lock washer
- hex nut

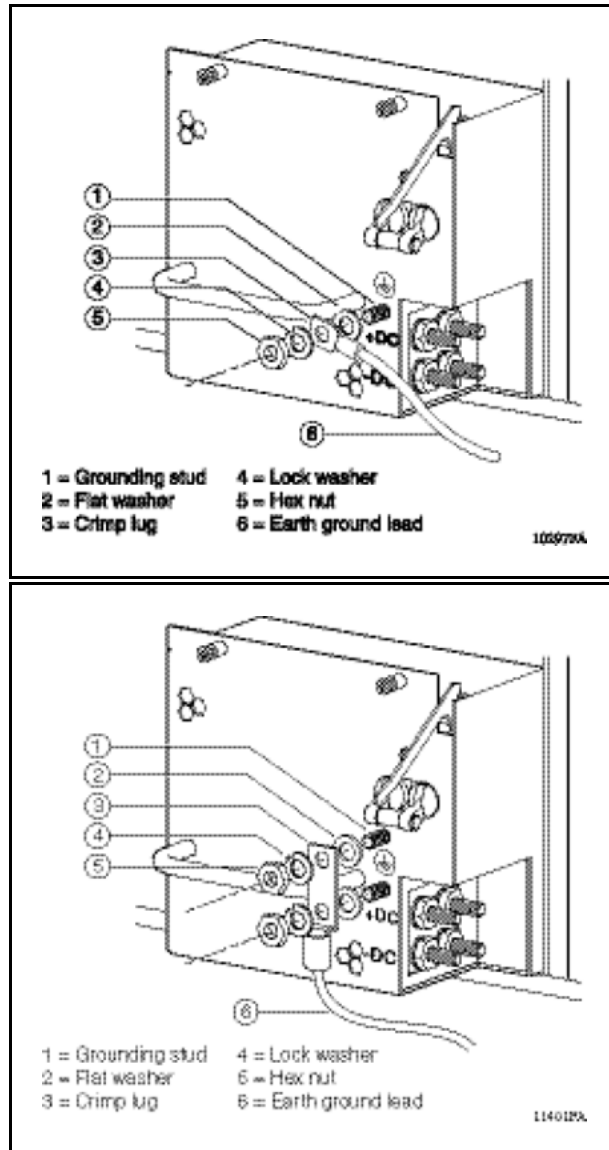

- 7 Attach the positive voltage lead to the positive terminal on the power supply, inserting a lock washer between the crimp lug and each hex nut.

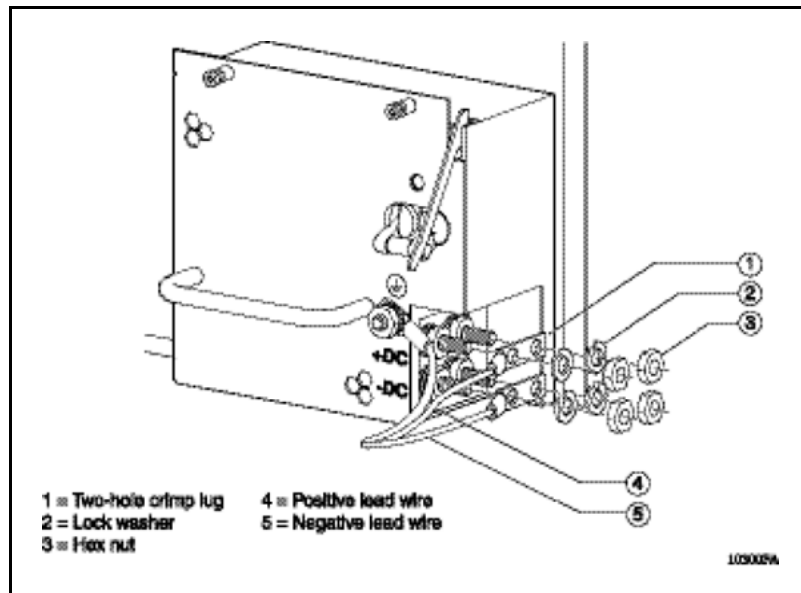

- 8 Attach the negative voltage lead to the negative terminal on the power supply, inserting a lock washer between the crimp lug and each hex nut.
- 9 Tighten the hex nut using a 7/16 in. hex wrench on each terminal.
- 10 Attach the earth ground cable to the system or rack ground for the DC input power source.
- 11 Attach the positive and negative terminal leads to the DC input power source according to the safety and technical specifications for your 48 V power distribution system.
- 12 Replace the plastic safety cover on the power supply using a Phillips screwdriver.
- 13 Firmly slide the power supply all the way into the bay.
- 14 Tighten the retaining screws until the power supply is firmly seated.
- 15 Turn the DC input power source on, or reset the power source circuit breaker, to provide power to the power supply.
- 16 Turn the power supply switch to the on position.

#### ATTENTION

If the chassis contains two or three non-redundant power supplies, turn on the power supplies simultaneously. If you wait longer to turn on the second power supply, one of the power supplies can turn off within 7 seconds. To correct this condition, turn off the power supplies for a short period of time and then simultaneously turn them on.

--End--



## Cable preparation

Prepare cables for connecting the DC power supply.

### Procedure steps

Step	Action
1	Strip 0.81 in. (2.1 cm) of insulation from the ends of the cables.
2	Crimp the lugs onto the cables using a standard crimping tool.
	<div style="border: 1px solid black; padding: 5px;">  <p><b>WARNING</b> Failure to properly crimp the lugs onto the cables constitutes a safety hazard.</p> </div>
3	If necessary, use a heat gun to shrink the tubing around the cable.

--End--

## Installing a breaker interface panel

For more information on installing a breaker interface panel (BIP), see *Installing the Breaker Interface Panel for the 8010co Chassis*, (NN46205-313).

## Installing a PCMCIA software card

Insert the PCMCIA card into the PCMCIA slot of the CPU.

## Starting the system

Start the system to run a set of internal self-diagnostic tests for all modules.

### Starting the system navigation

- [“Turning on AC power supplies” \(page 49\)](#)
- [“Turning on DC power supplies” \(page 50\)](#)
- [“LED power supply” \(page 51\)](#)

### Turning on AC power supplies

Turn on an Ethernet Routing Switch 8000 Series chassis with an AC power supply.

**Procedure steps**

<b>Step</b>	<b>Action</b>
1	Verify the AC power cords are connected to AC power outlets.
2	Turn each AC power supply switch to the on position simultaneously. Do not operate the 8010co chassis with only one power supply.
<div style="border: 1px solid black; padding: 5px;"> <p><b>ATTENTION</b> If the chassis contains two or three power supplies, turn on the power supplies simultaneously. If you wait longer to turn on the second power supply, one of the power supplies can turn off within 7 seconds. To correct this condition, turn off the power supplies for a short period of time and then simultaneously turn them on.</p> </div>	
3	Verify that the power LED on each power supply turns green.
4	Verify that the power supply status LEDs and the fan LED on the 8691SF/CPU or 8692SF/CPU modules turn green.
5	Verify that air flows from the cooling fans through the chassis vents.
<div style="border: 1px solid black; padding: 5px;"> <p><b>ATTENTION</b> The red fan tray fail LED may light briefly while the fans power to operational speed.</p> </div>	

---

--End--

---

**Turning on DC power supplies**

<b>Step</b>	<b>Action</b>
1	Turn the power switch on each DC power supply to the on position. It is not necessary to remove the bezel to turn the switch on.
<div style="border: 1px solid black; padding: 5px;"> <p><b>ATTENTION</b> If the chassis contains two or three power supplies, turn on the power supplies simultaneously. If you wait longer to turn on the second power supply, one of the power supplies can turn off within 7 seconds. To correct this condition, turn off the power supplies for a short period of time and then simultaneously turn them on.</p> </div>	
2	Verify that the power output LED for each power supply turns green.
3	Verify that the power supply status LEDs and the fan LED on the 8691SF/CPU or 8692SF/CPU modules turn green.

**ATTENTION**

The red fan tray fail LED may light briefly while the fans power to operational speed.

---

--End--

---

**LED power supply**

After you turn on the Ethernet Routing Switch 8000 Series, each module automatically initiates a diagnostic test to verify proper module function.

If the power supply LED remains off, do the following:

**Procedure steps**

Step	Action
1	Turn the power switch on each power supply to the off position.
2	Wait 1 minute.
3	Turn the power switch on each power supply to the on position.

---

--End--

---

**Verifying a successful installation**

- The following list describes a successful starting sequence for an Ethernet Routing Switch.
  - When power is applied to the Ethernet Routing Switch 8000, the green LED on each power supply and fan tray or cooling module turns on, and the Online LED for each module is amber.
  - Each module initiates a self-test, during which time the port and module LEDs display various patterns to indicate the progress of the self-test.
  - Upon successful completion of the self-test (within 2 or 3 minutes after power is applied to a fully loaded chassis), the module Online LED transitions from amber to green.
  - After 1 minute of operation, the fan tray Pass LED lights remain green.
  - If the LEDs on the modules light in this sequence, your installation is successful. Contact your network administrator to verify that the Ethernet Routing Switch 8000 is connected to the network.

---

Nortel Ethernet Routing Switch 8600  
Quick Start  
NN46205-310 02.01 Standard  
30 May 2008

---

# Configuration

---

This chapter contains configuration instructions for Ethernet Routing Switch 8600.

## Navigation

- [“Connecting a modem using the CLI” \(page 53\)](#)
- [“Connecting a modem using the NNCLI” \(page 56\)](#)
- [“Connecting a VT-100 terminal or PC for local access” \(page 58\)](#)
- [“Setting system date and time using the CLI” \(page 59\)](#)
- [“Setting system date and time using the NNCLI” \(page 59\)](#)
- [“Changing passwords using the CLI” \(page 22\)](#)
- [“Changing passwords using the NNCLI” \(page 22\)](#)
- [“Configuring the system using the setup utility” \(page 65\)](#)

## Connecting a modem using the CLI

This section describes how to connect a modem to the modem port on a module. You can access the CLI through a modem connection to the Ethernet Routing Switch 8690SF, 8691SF/CPU, or 8692SF/CPU modules.

The modem port is a DTE device is operating at:

- 9600 baud rate
- 8 data bits
- no parity
- one stop bit

**ATTENTION**

Nortel recommends to use the default settings for the Modem port for most modem installations.

Because the modem port will receive Data Set Ready (DSR) and Clear To Send (CTS) signals before transmitting, the DSR and CTS control lines are required in the cables. The modem port does not support inbound flow control; therefore, the port does not turn on and off control lines to indicate that the input buffer is full.

Before connecting a modem to an Ethernet Routing Switch you may need to configure the modem port using another type of CLI connection.

To configure the modem port using the Ethernet Routing Switch CLI, complete the steps in the following procedure.

### Prerequisites

- You need a DTE-to-DCE cable (straight or transmit cable) to connect the Nortel Ethernet Routing Switch 8600 to the modem.
- You must configure your client dial-up settings to establish the connection to the modem.

### Procedure steps

Step	Action
1	Configure the modem using the following command: <b>config bootconfig sio modem</b> Now you can enter options for this command level without retyping the first part of the command.
2	Configure port parameters based on the modem requirements: <ul style="list-style-type: none"><li>• <b>baud &lt;rate&gt;</b></li><li>• <b>8databits &lt;true   false&gt;</b></li><li>• <b>mode &lt;ascii   slip   ppp&gt;</b></li></ul> For information about the configuration requirements of your modem, see the documentation shipped with the modem.
<b>ATTENTION</b> Nortel recommends that before you configure SLIP or PPP modes, you become familiar with these protocols.	
3	If you assign the port mode to <b>slip</b> , configure the following parameters: <ul style="list-style-type: none"><li>• <b>slip-compression &lt;true   false&gt;</b></li><li>• <b>slip-rx-compression &lt;true   false&gt;</b></li></ul>

- 4 If you assign the port mode to **ppp**, configure the following parameters:
  - **mtu <bytes>**
  - **my-ip <ipaddr>**
  - **peer-ip <ipaddr>**
  - **pppfile <file>**
- 5 Turn off echo mode and return code messaging on the modem.
- 6 Connect the modem to the modem port.
- 7 Save the boot configuration.
- 8 Reboot the switch.

---

--End--

---

### Variable definitions

Variable	Value
<b>8databits &lt;true false&gt;</b>	Specifies either 8 (true) or 7 (false) data bits for each byte for software to interpret. The default is false.
<b>baud&lt;rate&gt;</b>	Sets the baud rate for the modem. The default is 9600.
<b>enable &lt;true false&gt;</b>	True sets the value to 7. False sets the value to 8. This setting is default.
<b>ascii</b>	Sets the default setting. This setting is recommended for most modem connections.
<b>slip</b>	Sets the port for serial line IP (SLIP) operation.
<b>ppp</b>	Sets the port for point-to-point protocol (PPP) operation.
<b>slip-compression &lt;true false&gt;</b>	Enables or disables the TCP/IP header compression. The default is false.
<b>slip-rx-compression &lt;true false&gt;</b>	Enables or disables the TCP/IP header compression on the receive packet. The default is false.
<b>mtu &lt;bytes&gt;</b>	Sets the maximum transmission unit for the point-to-point link (0–2048). The default is zero (0).
<b>my-ip &lt;ipaddr&gt;</b>	Sets the near-end IP address on the point-to-point link. The default is 0.0.0.0.

Variable	Value
<code>peer-ip &lt;ipaddr&gt;</code>	Sets the peer IP address on the point-to-point link. The default is 0.0.0.0.
<code>pppfile &lt;file&gt;</code>	Identifies the file to use for PPP initialization parameters.

### Procedure job aid: DTE-to-DCE straight-through pin assignments

**Table 3**  
DTE-to-DCE straight-through pin assignments

Signal	Switch	Modem	
	Pin number	DCE DB-9 pin number	DCE DB-25 pin number
RXD	2	2	3
TXD	3	3	2
DTR	4	4	20
GND	5	5	7
DSR	6	6	6
RTS	7	7	4
CTS	8	8	5

### Connecting a modem using the NNCLI

Connect a modem to a Ethernet Routing Switch 8600 to establish a connection with the switch. To connect a modem to an Ethernet Routing Switch you may need to set up the modem port using another type of connection, such as a terminal connection, to the NNCLI.

You can access the NNCLI through a modem connection to the Ethernet Routing Switch 8690SF, 8691SF/CPU, or 8692SF/CPU modules.

#### **ATTENTION**

Nortel recommends that you use the default settings for the modem port for most modem installations.

### Prerequisites

- You need a DTE-to-DCE cable (straight or transmit cable) to connect the Nortel Ethernet Routing Switch 8600 to the modem.
- You must configure your client dial-up settings to establish the connection to the modem.
- You must log on to the Global Configuration mode in the NNCLI.



**Procedure steps**

Step	Action
1	<p>Configure port parameters based on the requirements of the modem by using the following command:</p> <pre>boot config sio modem</pre> <p>For information about the configuration requirements of your modem, see the documentation shipped with the modem.</p> <div style="border: 1px solid black; padding: 5px;"> <p><b>ATTENTION</b> Nortel recommends that before you configure Serial Line IP (SLIP) or PPP, you become familiar with these protocols.</p> </div>
2	<p>If you assign the port mode to <code>slip</code>, use the following command to configure other slip parameters:</p> <pre>boot config sio modem [slip-compression] [slip-rx-compression]</pre>
3	<p>If you assign the port mode to <code>ppp</code>, use the following commands to configure other ppp parameters:</p> <pre>boot config sio modem [mtu &lt;bytes&gt;] [my-ip &lt;ipaddr&gt;] [peer-ip &lt;ipaddr&gt;] [pppfile &lt;file&gt;]</pre>
4	Turn off echo mode and return code messaging on the modem.
5	Connect the modem to the modem port.
6	Save the boot configuration.
7	<p>Optionally, shutdown and reinitialize the port by using the following command:</p> <pre>boot config sio modem restart</pre>
8	Reboot the switch.

--End--

**Variable definitions**

Variable	Value
<code>8databits</code>	Set number of data bits per byte for software to interpret.
<code>baud</code>	Set baud rate for the modem.
<code>mode</code>	Set serial port mode.
<code>mtu</code>	Sets point-to-point link maximum transmission unit.
<code>my-ip</code>	Sets my IP address on point-to-point link.

Variable	Value
peer-ip	Set peer IP address on point-to-point link.
pppfile	Use the file for PPP initialization parameters.
restart	Shutdown and re-initialize the port.
slip-compression	Enable TCP/IP header compression.
slip-rx-compression	Enable receive packet TCP/IP header compression.
my-ip	Sets my IP address on point-to-point link.

### Procedure job aid: DTE-to-DCE straight-through pin assignments

Table 4  
DTE-to-DCE straight-through pin assignments

Signal	Switch	Modem	
	Pin number	DCE DB-9 pin number	DCE DB-25 pin number
RXD	2	2	3
TXD	3	3	2
DTR	4	4	20
GND	5	5	7
DSR	6	6	6
RTS	7	7	4
CTS	8	8	5

### Connecting a VT-100 terminal or PC for local access

Connect a VT-100 terminal or a personal computer to the console port on a 8691SF/CPU or 8692SF/CPU module to establish a local CLI, NNCLI or Device Manager session.

#### Prerequisites

- A serial console cable with a nine-pin receptable connector.

#### Procedure steps

Step	Action
1	Connect an RS-232 cable to the console port on an 8691SF/CPU or 8692SF/CPU module.
2	Connect the other end of the RS-232 cable to a VT-100 terminal or PC serial port.

- 3 Turn on the terminal or PC.
- 4 Log on to the CLI.

---

--End--

---

## Setting system date and time using the CLI

Set the system date and time using the CLI.

### Procedure steps

---

#### Action

---

Set the date of the system by using the following command:

```
config setdate <MMddyymmss>
```

### Procedure job aid: config setdate command sample output

The following is a sample output to verify the `config setdate` command.

```
ERS-8606:5# config setdate 06062002191200
local time: THU JUN 06 19:12:00 2002 UTC
utc time:   THU JUN 06 19:12:00 2002 UTC
ERS-8606:5#
```

## Setting system date and time using the NNCLI

Set the system date and time using the NNCLI.

### Prerequisites

- You must log on to the privExec mode.

### Procedure steps

---

#### Action

---

Set the system date by using the following command:

```
clock set <MMddyymmss>
```

### Procedure job aid: clock set command output

The following is a sample output to verify the `clock set` command .

```
ERS-8610:5#clock set ?
<MMddyyyyhhmss> MMddyyyyhhmss
ERS-8610:5#clock set 09202007172000
local time: THU SEP 20 17:20:00 2007 UTC
utc time: THU SEP 20 17:20:00 2007 UTC
ERS-8610:5#_
```

## Changing passwords using the CLI

Set new passwords for each access level, or change the logon password for the different switch access.

The Ethernet Routing Switch Switch 8600 ships with default passwords configured for CLI access. When you use Simple Network Management Protocol version 3 (SNMPv3), you can change passwords that are in an encrypted format.

### Prerequisites

- You must have read-write-all privileges to change passwords. Passwords are saved to a hidden file to maintain security. The password associated with the user name or logon name is the optional **password** parameter.

### Procedure steps

---

#### Action

---

Change a password by using the following command:

```
config cli password
```

### Variable definitions

Use the data in the following table to use the **config cli password** command.

Variable	Value
<b>access level</b> <access level> <enable   disable>	Allows or blocks this access level. <ul style="list-style-type: none"> <li><b>access level</b> is an integer from 2 to 8.</li> <li><b>enable   disable</b> enables or disables the chosen access level.</li> </ul>
<b>aging</b> <days>	Sets the password age-out time. <ul style="list-style-type: none"> <li><b>days</b> is the number of days until the password expires from 1 to 365.</li> </ul>

<code>default-lockout-time &lt;secs&gt;</code>	<p>Changes the default lockout time after three invalid attempts.</p> <ul style="list-style-type: none"> <li>• <b>secs</b> is the lockout time in seconds from 60 to 6500. The default is 60 seconds.</li> </ul>
<code>info</code>	Shows the current level parameter settings and the next level directories.
<code>11 &lt;username&gt; [ &lt;password&gt; ]</code>	<p>Changes the Layer 1 read and write logon name or password or both.</p> <ul style="list-style-type: none"> <li>• <b>username</b> is the logon name</li> <li>• <b>password</b> is the password associated with the logon name.</li> </ul>
<code>12 &lt;username&gt; [ &lt;password&gt; ]</code>	<p>Changes the Layer 2 read and write logon name or password or both.</p> <ul style="list-style-type: none"> <li>• <b>username</b> is the logon name.</li> <li>• <b>password</b> is the password associated with the logon name.</li> </ul>
<code>13 &lt;username&gt; [ &lt;password&gt; ]</code>	<p>Changes the Layer 3 read and write logon name or password or both (applies only to the Ethernet Routing Switch 8600).</p> <ul style="list-style-type: none"> <li>• <b>username</b> is the logon name.</li> <li>• <b>password</b> is the password associated with the logon name.</li> </ul>
<code>14admin &lt;username&gt;</code>	Sets the Layer 4 Administrator logon to connect to the WSM. <sup>1</sup>
<code>14oper &lt;username&gt;</code>	Sets the Layer 4 Operator logon to connect to the WSM. <sup>1</sup>
<code>lockout-time &lt;HostAddress&gt; &lt;secs&gt;</code>	<p>Sets the Host lockout time.</p> <ul style="list-style-type: none"> <li>• <b>HostAddress</b> is the Host IP address in the format a.b.c.d.</li> <li>• <b>secs</b> is the lockout-out time in seconds for passwords from 60 to 65000. The default is 60 seconds.</li> </ul>

<code>min-passwd-len &lt;integer&gt;</code>	<p>Sets the minimum length for passwords in high-secure mode.</p> <ul style="list-style-type: none"> <li><code>integer</code> is a range from a minimum of 10 to 20.</li> </ul>
<code>oper &lt;username&gt;</code>	Sets the Operator logon to connect to the WSM. <sup>1</sup>
<code>password-history &lt;number&gt;</code>	<p>Specifies the number of previous passwords to remember.</p> <ul style="list-style-type: none"> <li><code>number</code> uses a configurable range of 3 to 32. The default is 3.</li> </ul>
<code>ro &lt;username&gt; [ &lt;password&gt; ]</code>	<p>Changes the read-only logon and/or password.</p> <ul style="list-style-type: none"> <li><code>username</code> is the logon name.</li> <li><code>password</code> is the password associated with the logon name.</li> </ul>
<code>rw &lt;username&gt; [ &lt;password&gt; ]</code>	<p>Changes the read and write logon name or password or both.</p> <ul style="list-style-type: none"> <li><code>username</code> is the logon name.</li> <li><code>password</code> is the password associated with the logon name.</li> </ul>
<code>rwa &lt;username&gt; [ &lt;password&gt; ]</code>	<p>Changes the read and write all logon name or password or both.</p> <ul style="list-style-type: none"> <li><code>username</code> is the logon name.</li> <li><code>password</code> is the password associated with the logon name.</li> </ul>
<code>slboper &lt;username&gt;</code>	Sets the server load balancing (SLB) Operator login to connect to the Web Switch Module (WSM). <sup>1</sup>
<code>slbadmin &lt;username&gt;</code>	Sets the SLB Administrator logon to connect to the WSM. <sup>1</sup>
<code>ssladmin &lt;username&gt;</code>	Sets the ssladmin logon to connect to and configure the SSL acceleration module (SAM).
<p><sup>1</sup> For more information about the WSM, see <i>Nortel Ethernet Routing Switch 8600 Web Switching Module Fundamentals</i>, (NN46205-314).</p>	

## Changing passwords using the NNCLI

Set new passwords for each access level, or change the logon or password for various access levels of the switch.

The Ethernet Routing Switch 8600 ships with default passwords set for access to the NNCLI. When using Simple Network Management Protocol version 3 (SNMPv3), you can change passwords that are in encrypted format.

### Prerequisites

- You must have read-write-all privileges to change passwords. For security, passwords are saved to a hidden file.
- You must log on to the global configuration mode.

### Procedure steps

Step	Action
1	Change a password by using the following command: <code>cli password &lt;word&gt; &lt;access-level&gt;</code>
2	Configure password options by using the following command: <code>password aging-time [day &lt;1-365&gt;] [default-lockout-time &lt;60-65 000&gt;] [min-passwd-len &lt;10-20&gt;] [password-history &lt;3-32&gt;]</code>
--End--	

### Variable definition

Use the data in the following table to use the password commands.

Variable	Value
<code>access level</code>	Allows or blocks this access level. The available access levels are: <ul style="list-style-type: none"> <li>• l4admin<sup>1</sup></li> <li>• l4oper<sup>1</sup></li> <li>• layer1 &lt;word&gt;</li> <li>• layer2</li> <li>• layer3 &lt;word&gt;</li> <li>• oper<sup>1</sup></li> <li>• read-only &lt;word&gt;</li> <li>• read-write &lt;word&gt;</li> </ul>

	<ul style="list-style-type: none"> <li>• read-write-all &lt;word&gt;</li> <li>• slbadmin<sup>1</sup></li> <li>• slboper<sup>1</sup></li> <li>• ssladmin</li> </ul> <p>&lt;word&gt; represents the new password with 0 to 20 characters.</p>
<b>aging-time &lt;1-365&gt;</b>	Sets the age-out time for passwords, in days.
<b>default-lockout-time &lt;60-65 000&gt;</b>	<p>Changes the default lockout time after three invalid attempts. Sets the lockout time in seconds and is in the range of 60 to 65 000. The default is 60 seconds.</p> <p>To set this option to the default value, use the <b>default</b> operator with the command.</p>
<b>lockout &lt;WORD 0-64&gt; time &lt;60-65000&gt;</b>	<p>Sets the Host lockout time.</p> <ul style="list-style-type: none"> <li>• <b>word</b> is the Host Internet Protocol (IP) address in the format a.b.c.d.</li> <li>• <b>time</b> is the lockout-out time in seconds for passwords from 60 to 65 000. The default is 60 seconds.</li> </ul>
<b>min-passwd-len &lt;10-20&gt;</b>	<p>Sets the minimum length for passwords in high-secure mode.</p> <p>To set this option to the default value, use the <b>default</b> operator with the command.</p>
<b>password-history &lt;3-32&gt;</b>	<p>Specifies the number of previous passwords to remember. The default is 3.</p> <p>To set this option to the default value, use the <b>default</b> operator with the command.</p>
<p><sup>1</sup> For more information about the WSM, see <i>Nortel Ethernet Routing Switch 8600 Web Switching Module Fundamentals</i>, (NN46205-314).</p>	



## Configuring the system using the setup utility

Use the setup utility for the initial configuration of the switch. The setup utility uses a series of questions to guide you through the configuration process.

### ATTENTION

Answer each question, or accept the default by pressing Enter. Each question includes the default value in brackets and the acceptable parameter options in parenthesis.

### Procedure steps

Step	Action
1	Power up the system.
2	Connect through the console and logon as a default user using the following command:  <code>install</code>
3	If you want to continue, type <code>y</code> .
4	Follow the setup utility prompts. See <a href="#">“Procedure job aid: Setup Utility prompt descriptions”</a> (page 66).
5	Restart the switch.

### ATTENTION

You must connect to the master CPU to use the install script. After running the setup utility, remember to reboot the switch.

A *Welcome to the Ethernet Routing Switch 8000 Setup Utility* message appears stating you are starting initial configuration of the switch. The data is stored in the `/flash/boot.cfg` and runtime configuration `flash/config.config` files.

### ATTENTION

You can use a default password to log on if the switch reboots without any previously configured password, and the high secure (hsecure) mode is enabled. However, you will be prompted to change the password.

For more information about the secure mode, see *Security*, NN46205-601.

--End--

### Procedure job aid: Setup Utility prompt descriptions

Prompt	Action
Please provide primary config-file path [/flash/config.cfg]:	Press Enter to accept the default ( <i>/flash/config.cfg</i> ), or enter a different file location for the primary configuration file. To store the configuration file on the PCMCIA card, use <i>/pcmcia/config.cfg</i> . Specifying the path to the file is optional.
Please provide primary image-file path [flash/p80a41xx.img]:	Press Enter to accept the default ( <i>/flash/p80a41xx.img</i> ), or enter a different file location for the primary image file. Specifying the path to the file is optional. If the runtime image resides on a PCMCIA card, you must specify the path (for example <i>/pcmcia/filename</i> ).
Please add system prompt [Ethernet Routing Switch-8606]:	Press Enter to accept the default (Ethernet Routing Switch-8606), or enter a different string of up to 20 characters.
Please select <b>CPU Master slot</b> (5/6) [5]:	Press Enter to accept the default (5), or specify 6 for the master CPU slot.
Master CPU mgmt port: autonegotiation [n] (y/n)?	Press Enter to accept the default(n), or enter <b>y</b> to indicate that you want the master CPU management port to use autonegotiation.
speed (10/100) [10]:	Press Enter to accept the default (10 Mbps), or specify 100 Mbps.
Do you want to enable automatic savetostandby mode [n] (y/n)?	Press Enter <b>y</b> if you want the boot and runtime configuration files to be saved on the backup CPU. Press Enter to accept the default ( <b>n</b> ), if you want the boot and runtime configuration files to be saved only on the primary CPU.
Do you want to enable m-mode support [n] (y/n)?	<p>Press Enter <b>y</b> if you want the chassis to run in 128 K or M mode. Press Enter to accept the default (<b>n</b>), if you want it to run in 32 K mode only.</p> <p>To run in 128 K mode, the CPU module must be an 8691 or higher and the switch must have at least one 8600 module (128 K module).</p> <p>If you enable m-mode support and you have a mixed configuration of modules, the E-modules and classic modules are disabled.</p>
Do you want to enable enhanced operation mode support [n] (y/n)?	Enter <b>y</b> if you want to enable enhanced operation mode. Accept the default ( <b>n</b> ), if you do not want to enable enhanced operation mode. If you enable enhanced operation mode and you have a mixed configuration of modules, the classic modules (E- or M-modules) are disabled.

Prompt	Action
Do you want to enable CPU High Availability mode [n] (y/n)?	Specify <b>y</b> if you want to enable CPU high availability (HA) mode. Accept the default ( <b>n</b> ), if you do not want to enable CPU HA mode.
Do you want to enable vlan-optimization-mode support [n] (y/n) ?	Specify <b>y</b> if you want to enable vlan-optimization-mode support. Accept the default ( <b>n</b> ) if you do not want to enable vlan-optimization-mode support.
Do you want to enable r-mode support [n] (y/n) ?	Specify <b>y</b> if you want to enable r-mode support. Accept the default ( <b>n</b> ) if you do not want to enable r-mode support.
Do you want to enable FTP [n] (y/n)?	Enter <b>y</b> if you want to enable FTP for remote users. Accept the default ( <b>n</b> ), if you do not want to enable FTP.
Do you want to enable RLOGIN [n] (y/n)?	Enter <b>y</b> if you want to enable Rlogin for remote users. Press Enter to accept the default ( <b>n</b> ), if you do not want to enable Rlogin.
Do you want to enable TELNET [n] (y/n)?	Enter <b>y</b> if you want to enable Telnet. Press Enter to accept the default ( <b>n</b> ), if you do not want to enable Telnet.
Do you want to enable TFTP [n] (y/n)?	Enter <b>y</b> if you want to enable TFTP. Press Enter to accept the default ( <b>n</b> ), if you do not want to enable TFTP.
Do you want to enable WEB server service [n] (y/n)?	Enter <b>y</b> if you want to enable WEB server service. Press Enter to accept the default ( <b>n</b> ), if you do not want to enable WEB server service.
IP Address for mgmt port in first CPU Slot [192.168.168.168/255.255.255.0]:	Enter the IP address of the management port in the first CPU slot.
IP Address for mgmt port in second CPU Slot [192.168.168.169/255.255.255.0]:	Enter the IP address of the management port in the second CPU slot.
IP Address for mgmt-virtual-ip [0.0.0.0/0.0.0.0]:	Enter the IP address of the virtual management port. Press Enter to accept the default (0.0.0.0/0.0.0.0) if you do not want to specify an IP address.
First net mgmt route [0.0.0.0:0.0.0.0]:	Enter the IP address of the first network management route.

Prompt	Action
Second net mgmt route [0.0.0.0:0.0.0.0]:	Enter the IP address of the second network management route (static route from the network management port to a device in the network). For security reasons, the system does not accept a route to a network that conflicts with the main nonmanagement routing table, and, therefore, does not accept a default route of 0.0.0.0.
Third net mgmt route [0.0.0.0:0.0.0.0]:	Enter the IP address of the third network management route (static route from the network management port to a device in the network).
Fourth net mgmt route [0.0.0.0:0.0.0.0]:	Enter an IP address of the fourth network management route (static route from the network management port to a device in the network).
IP address of the default VLAN [0.0.0.0/0.0.0.0]:	Enter the IP address of the default virtual LAN (VLAN).
Do you want to save the changes  [Saving the parameters will update the files /flash/boot.cfg and /flash/config.cfg] (y/n)?	Enter <b>y</b> to save the boot and runtime configuration files. Press Enter <b>n</b> if you do not want to save your changes.

---

## Translation of safety messages

---

### Fan tray safety warning message

**WARNING****Risk of personal injury**

Grasp the fan tray at the middle of the front panel, and be careful to keep your fingers out of the fan blades.

**WARNING****AVERTISSEMENT****Risques de blessure corporelle**

Saisissez le boîtier du ventilateur au milieu du panneau avant en veillant à maintenir vos doigts éloignés des pales.

**WARNING****WARNUNG****Verletzungsrisiko**

Greifen Sie das Gehäuse des Lüfters vorne in der Mitte, und achten Sie darauf, dass Ihre Finger nicht zwischen die Blätter des Lüfters geraten.

**WARNING****ADVERTENCIA****Riesgo de lesiones**

Sostenga la bandeja del ventilador en la mitad del panel delantero y tenga cuidado de mantener los dedos alejados de las aspas.



**WARNING**  
**AVISO**  
**Risco de ferimento**

Segure a bandeja do ventilador no meio do painel frontal e tenha cuidado para não colocar os dedos nas lâminas do ventilador.



**WARNING**  
**AVVISO**  
**Rischio di lesioni personali**

Afferrare il vassoio del ventilatore nella parte centrale del pannello frontale e prestare attenzione a non toccare le lame.

### Preventing back injury warning statement



**WARNING**  
**Risk of personal injury**

It requires two people to lift a fully-loaded chassis. To prevent injury, keep your back straight and lift with your legs. An Ethernet Routing Switch 8010 chassis weighs approximately 101 kg (225 lbs). An Ethernet Routing Switch 8006 chassis weighs approximately 77 kg (170 lbs). An Ethernet Routing Switch 8003 chassis weighs approximately 49.5 kg (110 lbs).



**WARNING**  
**AVERTISSEMENT**  
**Risques de blessure corporelle**

Deux personnes sont nécessaires pour soulever un châssis rempli. Pour éviter tout risque de blessure, gardez le dos droit et utilisez l'appui de vos jambes pour soulever la charge. Le châssis d'un commutateur-routeur Ethernet 8010 pèse environ 101 kg. Le châssis d'un commutateur-routeur Ethernet 8006 pèse environ 77 kg. Le châssis d'un commutateur-routeur Ethernet 8003 pèse environ 49,5 kg.



**WARNING**  
**WARNUNG**  
**Verletzungsrisiko**

Es sind 2 Personen notwendig, um ein voll besetztes Chassis anzuheben. Zur Vermeidung von Verletzungen halten Sie beim Heben Ihren Rücken gerade, und heben Sie das Gewicht aus den Beinen heraus. Das Chassis des Ethernet Routing Switch 8010 wiegt ungefähr 101 kg (225 lbs). Das Chassis des Ethernet Routing Switch 8006 wiegt ungefähr 77 kg (170 lbs). Das Chassis des Ethernet Routing Switch 8003 wiegt ungefähr 49,5 kg (110 lbs).



**WARNING**  
**ADVERTENCIA**  
**Riesgo de lesiones**

Se necesitan dos personas para levantar un chasis completamente cargado. Para evitar lesiones, mantenga la espalda recta y realice la fuerza con las piernas. El chasis de Ethernet Routing Switch 8010 pesa aproximadamente 101 kg (225 lb). El chasis de Ethernet Routing Switch 8006 pesa aproximadamente 77 kg (170 lb). El chasis de Ethernet Routing Switch 8003 pesa aproximadamente 49,5 kg (110 lb).



**WARNING**  
**AVISO**  
**Risco de ferimento**

Para erguer um chassi totalmente carregado, são necessárias duas pessoas. Para evitar ferimentos, mantenha sua coluna reta e erga suas pernas. Um chassi Ethernet Routing Switch 8010 pesa aproximadamente 101 kg (225 lbs). Um chassi Ethernet Routing Switch 8006 pesa aproximadamente 77 kg (170 lbs). Um chassi Ethernet Routing Switch 8003 pesa aproximadamente 49,5 kg (110 lbs).



**WARNING**

**AVVISO**

**Rischio di lesioni personali**

Sono necessarie due persone per sollevare uno chassis a pieno carico. Per evitare lesioni, mantenere la schiena dritta e sollevarsi con le gambe. Uno chassis Ethernet Routing Switch 8010 pesa circa 101 kg (225 libbre). Uno chassis Ethernet Routing Switch 8006 pesa circa 77 kg (170 libbre). Uno chassis Ethernet Routing Switch 8003 pesa circa 49,5 kg (110 libbre).

**Preventing electrical shock warning statement**



**WARNING**

**Risk of injury by electric shock**

To avoid the danger of electrical shock, be careful when working with power equipment and connections.



**WARNING**

**AVERTISSEMENT**

**Risques de blessure par choc électrique**

Pour prévenir les risques de choc électrique, soyez vigilants lorsque vous manipulez des équipements et des connexions électriques.



**WARNING**

**WARNUNG**

**Verletzungsrisiko durch**

Stromschlag Zur Vermeidung eines Stromschlages gehen Sie beim Umgang mit stromführenden Geräten und Anschlüssen sorgfältig vor.



**WARNING**

**ADVERTENCIA**

**Riesgo de lesiones por choques eléctricos**

Para evitar choques eléctricos, maneje los equipos y conexiones eléctricas con cuidado.



**WARNING****AVISO****Risco de ferimento por choque elétrico**

Para evitar o perigo do choque elétrico, tenha cuidado ao trabalhar com equipamentos e conexões elétricos.

**WARNING****AVVISO****Rischio di lesioni per shock elettrico**

Per evitare il pericolo di shock elettrico, prestare attenzione quando si lavora con l'alimentatore e i collegamenti.

## Preventing hand injury warning statement

**WARNING****Risk of injury by fan blades**

When removing the fan module, do not put your hands into the opening because of the spinning fan blades in the adjacent fan modules.

**WARNING****AVERTISSEMENT****Risques de blessure provoquée par les pales du ventilateur**

Lorsque vous retirez le module du ventilateur, ne mettez pas vos mains dans l'ouverture car les pales des modules adjacents en fonctionnement risqueraient de vous blesser.

**WARNING****WARNUNG****Verletzungsrisiko durch Lüfter-Blätter**

Greifen Sie beim Entfernen des Lüftungsmoduls, wegen der rotierenden Blätter des sich in der Nähe befindlichen Lüfters, nicht in die Öffnung.



**WARNING**  
**ADVERTENCIA**  
**Riesgo de lesiones por las aspas del ventilador**

Cuando deba retirar el módulo del ventilador, no coloque las manos en la abertura para evitar accidentes con las aspas de los ventiladores adyacentes.



**WARNING**  
**AVISO**  
**Risco de ferimento com lâmina do ventilador**

Ao remover o módulo do ventilador, não coloque as mãos na abertura porque existem lâminas que giram nos módulos adjacentes.



**WARNING**  
**AVVISO**  
**Rischio di lesioni causate dalle lame del ventilatore**

Quando si rimuove il modulo del ventilatore, non inserire le mani nell'apertura, data la presenza delle lame rotanti del ventilatore nei moduli adiacenti.

### Safety danger statement



**DANGER**  
**Risk of injury by electric shock**

Failure to properly crimp the lugs onto the cables constitutes a safety hazard



**DANGER**  
**DANGER**  
**Risques de blessure par choc électrique**

Pour votre sécurité, vérifiez que les cosses sont correctement serties sur les câbles.



**DANGER**  
**GEFAHR**  
**Verletzungsrisiko durch Stromschlag**

Es besteht ein Sicherheitsrisiko, wenn die Anschlussstücke nicht ordnungsgemäß auf die Kabel geklemmt werden.



**DANGER**  
**PELIGRO**  
**Riesgo de lesiones por choques eléctricos**

Para evitar riesgos, pliegue correctamente hacia adentro los terminales de los cables.



**DANGER**  
**PERIGO**  
**Risco de ferimento por choque elétrico**

Enrolar os suportes aos cabos de maneira incorreta implica em um risco de segurança.



**WARNING**  
**PERICOLO**  
**Rischio di lesioni per shock elettrico**

Il piegamento non corretto delle linguette nei cavi costituisce un rischio per la sicurezza.

## Injury to eye warning statement



**WARNING**  
**Risk of eye injury by laser**

Fiber optic equipment can emit laser or infrared light that can injure your eyes. Never look into an optical fiber or connector port. Always assume that fiber optic cables are connected to a light source.



**WARNING**  
**AVERTISSEMENT**  
**Risques de blessure oculaire par lumière laser**

L'équipement de fibres optiques peut émettre une lumière laser ou infrarouge nuisible à vos yeux. Ne regardez jamais en direction de fibres optiques ou d'un port connecteur. Supposez toujours que les câbles de fibres optiques sont connectés à une source de lumière.



**WARNING**  
**WARNUNG**  
**Risiko einer Augenverletzung durch**

Laser Glasfasergeräte können Laserstrahlen oder ultraviolettes Licht aussenden, das Ihre Augen verletzen kann. Schauen Sie nie direkt in einen Glasfaserleiter oder Verbindungsanschluss. Gehen Sie immer davon aus, dass Glasfaserkabel mit einer Lichtquelle verbunden sind.



**WARNING**  
**ADVERTENCIA**  
**Riesgo de lesión en los ojos por láser**

El equipo de fibra óptica puede emitir una luz láser o infrarroja que dañe sus ojos. Nunca mire un puerto de fibra óptica o conector. Siempre asuma que los cables de fibra óptica están conectados a una fuente de luz.



**WARNING**  
**AVISO**  
**O laser pode causar ferimentos no olho**

O equipamento de fibra ótica pode emitir laser ou luz infravermelha que pode causar danos a sua vista. Nunca olhe para dentro da fibra ótica ou da porta do conector. Tenha sempre em mente que os cabos de fibra ótica estão ligados a uma fonte de luz.



**WARNING**  
**AVVISO**  
**Rischio di ustioni agli occhi dovute al laser**

Le apparecchiature con fibre ottiche possono emettere raggi laser o infrarossi in grado di provocare ferite agli occhi. Non guardare mai all'interno di una porta di connessione o una fibra ottica. Tenere sempre presente che i cavi a fibra ottica sono collegati a una sorgente luminosa.

## Safety practices and the hazards danger statement



### **DANGER**

#### **Risk of injury by electric shock**

Before working on this equipment, be aware of proper safety practices and the hazards involved with electrical circuits. Use only power cords that have a grounding path. Ensure the switch is properly grounded before powering on the unit.



### **DANGER**

### **DANGER**

#### **Risques de blessure par choc électrique**

Avant de manipuler cet équipement, vous devez prendre connaissance des pratiques de sécurité appropriées et des risques associés aux circuits électriques. Utilisez uniquement des cordons d'alimentation possédant un conducteur de terre. Assurez-vous que le commutateur est correctement relié à la terre avant de mettre l'unité sous tension.



### **DANGER**

### **GEFAHR**

#### **Verletzungsrisiko durch**

Stromschlag Informieren Sie sich über entsprechende Sicherheitsmaßnahmen und die mit Stromkreisen verbundenen Gefahren, bevor Sie mit diesem Gerät arbeiten. Verwenden Sie nur Netzkabel mit Erdungspfad. Stellen Sie sicher, dass der Schalter ordnungsgemäß geerdet ist, bevor Sie das Gerät einschalten.



### **DANGER**

### **PELIGRO**

#### **Riesgo de lesión por electrocución**

Antes de trabajar con este equipo, infórmese acerca de las medidas de seguridad adecuadas y de los peligros relacionados con los circuitos eléctricos. Utilice sólo cables de corriente que tengan puesta a tierra. Asegúrese de que el interruptor tenga puesta a tierra antes de encender la unidad.



**DANGER**  
**PERIGO**  
**Risco de ferimentos por choque elétrico**

Antes de começar a trabalhar com o equipamento, esteja ciente das práticas de segurança adequadas e dos perigos inerentes a circuitos elétricos. Use apenas cabos de alimentação que tenham ligação à terra. Certifique-se de que o switch esteja devidamente aterrado antes de ligar o aparelho.



**DANGER**  
**PERICOLO**  
**Rischio di scosse elettriche**

Prima di utilizzare questa apparecchiatura, considerare le appropriate pratiche di sicurezza e i pericoli correlati ai circuiti elettrici. Utilizzare esclusivamente cavi di alimentazione dotati di un percorso per il collegamento a terra. Prima di attivare l'alimentazione dell'unità, accertarsi che l'interruttore sia adeguatamente collegato alla messa a terra.

## Safety practices and the hazards danger statement



**DANGER**  
**Risk of injury by electric shock**

Before working on this equipment, be aware of proper safety practices and the hazards involved with electrical circuits. Use only power cords that have a grounding path. Ensure the switch is properly grounded before powering on the unit.



**DANGER**  
**Risques de blessure par choc électrique**

Avant de manipuler cet équipement, vous devez prendre connaissance des pratiques de sécurité appropriées et des risques associés aux circuits électriques. Utilisez uniquement des cordons d'alimentation possédant un conducteur de terre. Assurez-vous que le commutateur est correctement relié à la terre avant de mettre l'unité sous tension.



**DANGER**  
**GEFAHR**  
**Verletzungsrisiko durch Stromschlag**

Informieren Sie sich über entsprechende Sicherheitsmaßnahmen und die mit Stromkreisen verbundenen Gefahren, bevor Sie mit diesem Gerät arbeiten. Verwenden Sie nur Netzkabel mit Erdungspfad. Stellen Sie sicher, dass der Schalter ordnungsgemäß geerdet ist, bevor Sie das Gerät einschalten.



**DANGER**  
**PELIGRO**  
**Riesgo de lesión por electrocución**

Antes de trabajar con este equipo, infórmese acerca de las medidas de seguridad adecuadas y de los peligros relacionados con los circuitos eléctricos. Utilice sólo cables de corriente que tengan puesta a tierra. Asegúrese de que el interruptor tenga puesta a tierra antes de encender la unidad.



**DANGER**  
**PERIGO**  
**Risco de ferimentos por choque elétrico**

Antes de começar a trabalhar com o equipamento, esteja ciente das práticas de segurança adequadas e dos perigos inerentes a circuitos elétricos. Use apenas cabos de alimentação que tenham ligação à terra. Certifique-se de que o switch esteja devidamente aterrado antes de ligar o aparelho.



**DANGER**  
**PERICOLO**  
**PERICOLO Rischio di scosse elettriche**

Prima di utilizzare questa apparecchiatura, considerare le appropriate pratiche di sicurezza e i pericoli correlati ai circuiti elettrici. Utilizzare esclusivamente cavi di alimentazione dotati di un percorso per il collegamento a terra. Prima di attivare l'alimentazione dell'unità, accertarsi che l'interruttore sia adeguatamente collegato alla messa a terra.

## Preventing electric shock danger statement



**DANGER**

**Risk of injury by electric shock**

Before you continue with this procedure, ensure that the DC power source is switched off.



**DANGER**

**Risques de blessure par choc électrique**

Avant de poursuivre cette procédure, assurez-vous que la source d'alimentation en courant continu est éteinte.



**DANGER**

**GEFAHR**

**Verletzungsrisiko durch**

Stromschlag Bevor Sie dieses Verfahren fortsetzen, stellen Sie sicher, dass die Stromquelle für Wechselstrom ausgeschaltet ist.



**DANGER**

**PELIGRO**

**Riesgo de lesión por electrocución**

Antes de continuar con este proceso, asegúrese de que la fuente de alimentación de CC esté apagada.



**DANGER**

**PERIGO**

**Risco de ferimentos por choque elétrico**

Antes de continuar este procedimiento, certifique-se de que a fonte de energia DC está desligada.



**DANGER**

**PERICOLO**

**Rischio di scosse elettriche**

Prima di continuare questa procedura, accertarsi che la fonte di alimentazione CC sia disattivata.





## Nortel Ethernet Routing Switch 8600

# Quick Start

Copyright © 2008 Nortel Networks  
All Rights Reserved.

Printed in Canada, India, and the United States of America

Release: 5.0

Publication: NN46205-310

Document status: Standard

Document revision: 02.01

Document release date: 30 May 2008

To provide feedback or to report a problem in this document, go to [www.nortel.com/documentfeedback](http://www.nortel.com/documentfeedback).

[www.nortel.com](http://www.nortel.com)

### LEGAL NOTICE

While the information in this document is believed to be accurate and reliable, except as otherwise expressly agreed to in writing NORTEL PROVIDES THIS DOCUMENT "AS IS" WITHOUT WARRANTY OR CONDITION OF ANY KIND, EITHER EXPRESS OR IMPLIED. The information and/or products described in this document are subject to change without notice.

Nortel, the Nortel logo, the Globemark, and Passport are trademarks of Nortel Networks.

All other trademarks are the property of their respective owners.

#### **ATTENTION**

For information about the regulatory and safety precautions, read "Regulatory messages and safety precautions" in this guide.

For information about the software license, read "Software license" in this guide.

For a list of safety messages used in this guide and their translations, see "Translations of safety messages".



## Free Manuals Download Website

<http://myh66.com>

<http://usermanuals.us>

<http://www.somanuals.com>

<http://www.4manuals.cc>

<http://www.manual-lib.com>

<http://www.404manual.com>

<http://www.luxmanual.com>

<http://aubethermostatmanual.com>

Golf course search by state

<http://golfingnear.com>

Email search by domain

<http://emailbydomain.com>

Auto manuals search

<http://auto.somanuals.com>

TV manuals search

<http://tv.somanuals.com>