

NÜVÖ®

The Sound of LiVing.

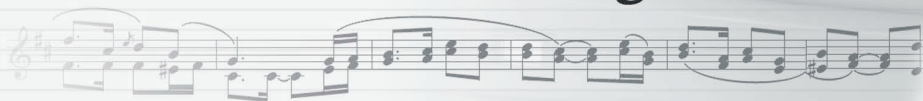

Concerto™

Grand

Six-Source, Eight-Zone Audio Distribution System
NV-18GMS, NV-18GXS
Installation Guide

ENGLISH

Danger

Exposure to extremely high noise levels may cause a permanent hearing loss. Individuals vary considerably to noise induced hearing loss but nearly everyone will lose some hearing if exposed to sufficiently intense noise for a sufficient time. The U.S. Government's Occupational Safety and Health Administration (OSHA) has specified the following permissible noise level exposures:

DURATION PER DAY (HOURS)	8	6	4	3	2	1
SOUND LEVEL (dB)	90	93	95	97	100	103

According to OSHA, any exposure in the above permissible limits could result in some hearing loss. Ear plugs or protectors in the ear canal or over the ears must be worn when operating this amplification system in order to prevent a permanent hearing loss. If exposure in excess of the limits as put forth above, to insure against potentially harmful exposure to high sound pressure levels, it is recommended that all persons exposed to equipment capable of inducing high sound pressure levels, such as this amplification system, be protected by hearing protectors while this unit is in operation.

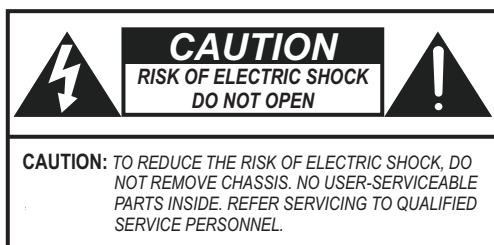

AVIS: RISQUE DE CHOC ELECTRIQUE-NE PAS OUVRIR.



THIS SYMBOL IS INTENDED TO ALERT THE USER TO THE PRESENCE OF NON-INSULATED "DANGEROUS VOLTAGE" WITHIN THE PRODUCT'S ENCLOSURE THAT MAY BE OF SUFFICIENT MAGNITUDE TO CONSTITUTE A RISK OF ELECTRIC SHOCK TO PERSONS.



THIS SYMBOL IS INTENDED TO ALERT THE USER TO THE PRESENCE OF IMPORTANT OPERATING AND MAINTENANCE (SERVICING) INSTRUCTIONS IN THE LITERATURE ACCOMPANYING THE UNIT.



APPARATUS SHALL NOT BE EXPOSED TO DRIPPING OR SPLASHING AND THAT NO OBJECTS FILLED WITH LIQUIDS, SUCH AS VASES, SHALL BE PLACED ON THE APPARATUS.

IMPORTANT SAFETY INSTRUCTIONS

1. Read all safety and operating instructions before using this product.
2. All safety and operating instructions should be kept for future reference.
3. Read and understand all warnings listed on the operating instructions.
4. Follow all operating instructions to operate this product.
5. This product should not be used near water, i.e. bathtub, sink, swimming pool, wet basement, etc.
6. Only use dry cloth to clean this product.
7. Do not block any ventilation openings, It should not be placed flat against a wall or placed in a built-in enclosure that will impede the flow of cooling air.
8. Do not install this product near any heat sources ; such as, radiators, heat registers, stove or other apparatus (including heat producing amplifiers) that produce heat.
9. Do not defeat the safety purpose of the polarized or grounding-type plug. A polarized plug has two blades with one wider than the other. A grounding-type plug has two blades and a third grounding prong. The wide blade or the third prong are provided for your safety. If the provided plug does not fit into your outlet, consult an electrician for replacement of the obsolete outlet.
10. Protect the power cord being walked on or pinched, particularly at plugs, convenience receptacles and the point where they exit from the apparatus. Do not break the ground pin of the power supply cord.
11. Only use attachments specified by the manufacturer.
12. Use only with the cart, stand, tripod, bracket, or table specified by the manufacturer or sold with the apparatus. When a cart is used, use caution when moving cart/apparatus combination to avoid injury from tip-over.
13. Unplug this apparatus during lightning storms or when unused for long periods of time.
14. Care should be taken so that objects do not fall and liquids are not spilled into the unit through the ventilation ports or any other openings.
15. Refer all servicing to qualified service personnel. Servicing is required when the apparatus has been damaged in any way; such as, power-supply cord or plug is damaged, liquid has been spilled or objects have fallen into the apparatus, the apparatus has been exposed to rain or moisture, does not operate normally or has been dropped.
16. **WARNING:** To reduce the risk of fire or electric shock, do not expose this apparatus to rain or moisture.

FRENCH

Danger

L'exposition a des niveaux eleves de bruit peut provoquer une perte permanente de l'audition, Chaque organisme humain reagit differemment quant a la perte de l'audition, mais quasiment tout le monde subit une diminution de l'acuite auditive lors d'une exposition suffisamment longue au bruit intense. Les autorites competentes en reglementation de bruit ont defini les expositions tolerees aux niveaux de bruits:

DURE EN HEURES PAR JOUR	8	6	4	3	2	1
INIVEAU SONORE CONTINU EN dB	90	93	95	97	100	103

Selon les autorites, toute exposition dans les limites citees ci-dessus, peuvent provoquer certaines pertes d'audition. Des bouchons ou protections dans l'appareil auditif ou sur l'oreille doivent etre portes lors de l'utilisation de ce systeme d'amplification afin de prevenir le risque de perte permanente de l'audition, Dans le cas d'expositions superieures aux limites precitees il est recommande, afin de se premunir contre les expositions aux pressions acoustiques lvees potentiellement dangeure u ses, aux personnes exposees aux equipements capables de delivrer de telles puissances, tels ce systeme d'amplification en fonctionnement, de proteger l'appareil auditif.



CE SYMBOLE A POUR BUT D'AVERTIR L'UTILISATEUR DE LA PRESENCE DE VOLTAGE DANGEREUX NON-ISOLE A L'INTERIEUR DE CE PRODUIT QUI PEUT ETRE DE PUISSANCE SUFFISAMMENT IMPORTANTE POUR PROVOQUER UN CHOC ELECTRIQUE AUX PERSONNES.



CE SYMBOLE A POUR BUT D'AVERTIR L'UTILISATEUR DE LA PRESENCE D'INSTRUCTIONS D'UTILISATION ET DE MAINTENANCE DANS LES DOCUMENTS FOURNIS AVEC CE PRODUIT.



AFIN DE REDUIRE LES RISQUÉ D'INCENDIE ET DE DECHARGE ELECTRIQUE, NE PAS EXPOSER CET APPAREIL A LA PLUIE OU A L'HUMIDITE.

IMPORTANTES INSTRUCTIONS DE SECURITE

1. Lire avec attention toutes les recommandations et précautions d'emploi avant d'utiliser ce produit.
2. Toutes les recommandations et précautions d'emploi doivent être conservées afin de pouvoir s'y reporter si nécessaire.
3. Lire et comprendre tous les avertissements énumérés dans les précautions d'emploi.
4. Suivre toutes les précautions d'emploi pour utiliser ce produit.
5. Ce produit ne doit pas être utilisé près d'eau, comme par exemple baignoires, éviers, piscine, sous-sol humides ... Etc.
6. Utiliser exclusivement un chiffon sec pour nettoyer ce produit.
7. Ne bloquer aucune ouverture de ventilation. Ne pas placer le produit tout contre un mur ou dans une enceinte fermée, cela générerait le flux d'air nécessaire au refroidissement.
8. Ne pas placer le produit près de toute source de chaleur telle que radiateurs, arrivées d'air chaud, fourneaux ou autres appareils générant de la chaleur (incluant les amplificateurs producteurs de chaleur) .
9. Ne pas négliger la sécurité que procure un branchement polarisé ou avec raccordement à la terre, Un branchement polarisé comprend deux fiches dont l'une est plus large que l'autre. Un branchement à la terre comprend deux fiches plus une troisième reliée à la terre. Si la fiche secteur fournie ne s'insert pas dans votre prise de courant. consulter un 'électricien afin de remplacer votre prise obsolète.
10. Protéger le cordon d'alimentation de tout écrasement ou pincement, particulièrement au niveau des fiches, des réceptacles utilisés et à l'endroit de sortie de l'appareil. Ne pas casser la fiche de terre du cordon d'alimentation.
11. Utiliser uniquement les accessoires spécifiés par le constructeur.
12. Utiliser uniquement avec le chariot de transport, le support, le trépied, la console ou la table spécifiés par le constructeur ou vendus avec l'appareil. Lors de l'utilisation d'un chariot, bouger avec précaution l'ensemble chariotlappareil afin d'éviter les dommages d'un renversement.
13. Débrancher cet appareil lors d'orages ou s'il n'est pas utilisé pendant une longue période.
14. Des précautions doivent être prises afin qu'aucun objet ne tombe et qu'aucun liquide ne se répande à l'intérieur de l'appareil par les orifices de ventilation ou n'importe quelle autre ouverture.
15. Pour toutes interventions techniques s'adresser à un technicien qualifié. L'intervention technique est nécessaire lorsque l'appareil a été endommagé de n'importe quelle façon, comme par exemple si le cordon secteur ou sa fiche sont détériorés, si du liquide a coulé ou si des objets sont tombés à l'intérieur de l'appareil, si l'appareil a été exposé à la pluie ou à l'humidité, s'il ne fonctionne pas normalement ou s'il est tombé.
16. ATTENTION: Pour réduire le risque d'incendie ou de choc électrique ne pas exposer l'appareil à la pluie ou à l'humidité.

Introduction

Congratulations on the purchase of your NuVo System. The Grand Concerto System is truly NuVo's newest masterpiece. The Grand Concerto's state-of-the-art interface and NuVoNet communication with the Grand Concerto Suite of audio components offer the best, most affordable whole-home audio system available.

Grand Concerto delivers 80 startlingly clear watts of sound to up to 16 independent zones simultaneously. NuVo's Generation D, class D amplification uses the newest technology in digital amplification, which requires less power and is able to operate at peak capacity while generating very little heat.

The Grand Concerto Control Pad interface offers the elegance and control of an expensive touch panel at a keypad price. The new OLED (organic light emitting diode) display allows up to eight lines of text for easily scrolling through music titles and menu selections. Capacitive touch controls provide immediate access to the audio sources without external rubber buttons. The result is a single piece of polycarbonate plastic that provides ultra-responsive water-resistant access to your music from any room of the house.

The EZ IR Learning Station makes system setup easy and intuitive. Creating customized audio control is as easy as typing in a Windows template. The Learning Station will allow IR commands for the source equipment to be stored in files for future use, making programming the system as simple as the push of a button.

This installation manual outlines the installation and setup of your new Grand Concerto System. We recommend that you read this manual prior to installing your system. Proper installation and setup will insure years of audio enjoyment.

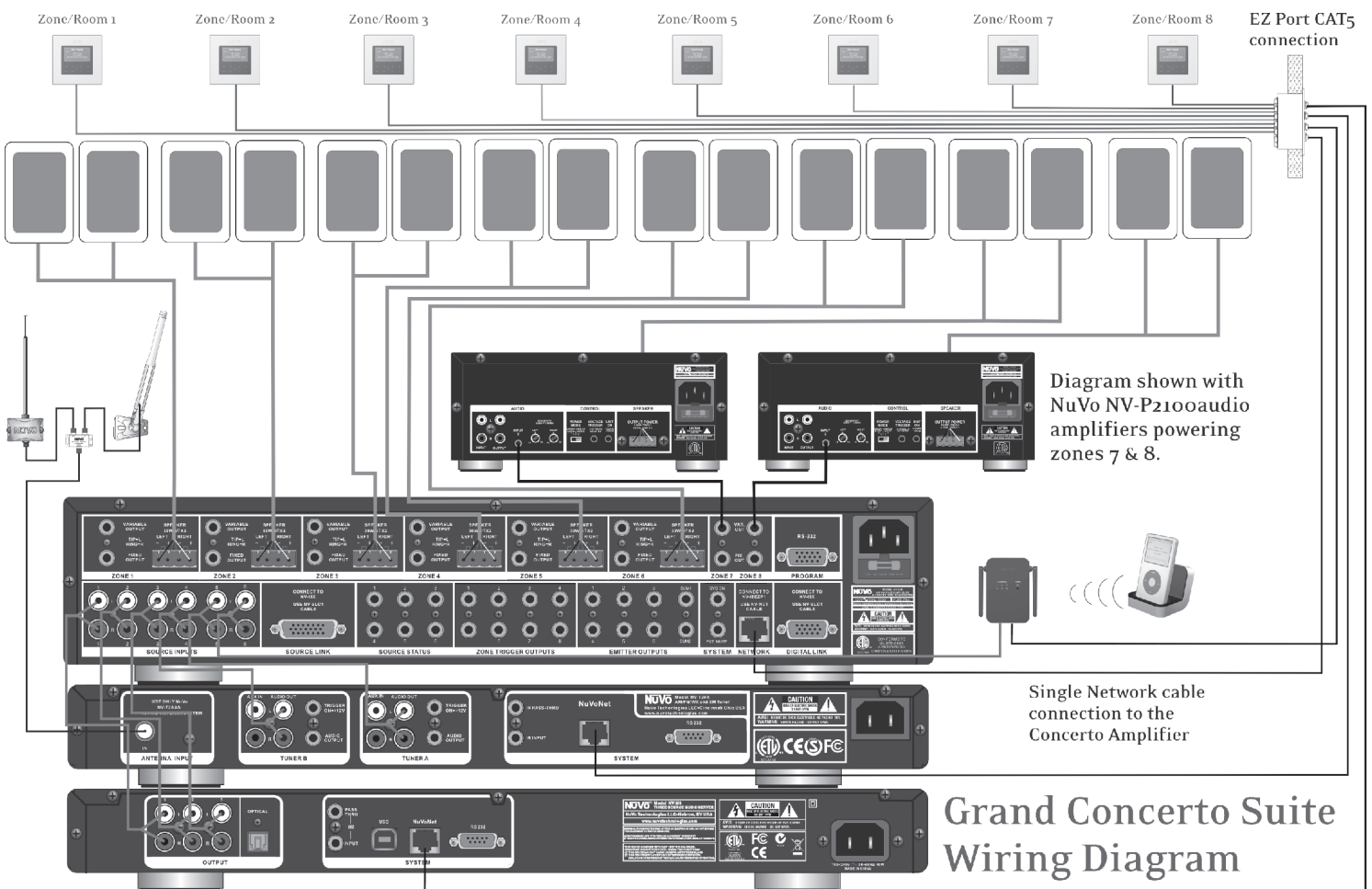

**Grand Concerto Suite
Wiring Diagram**

Grand Concerto Back Panel

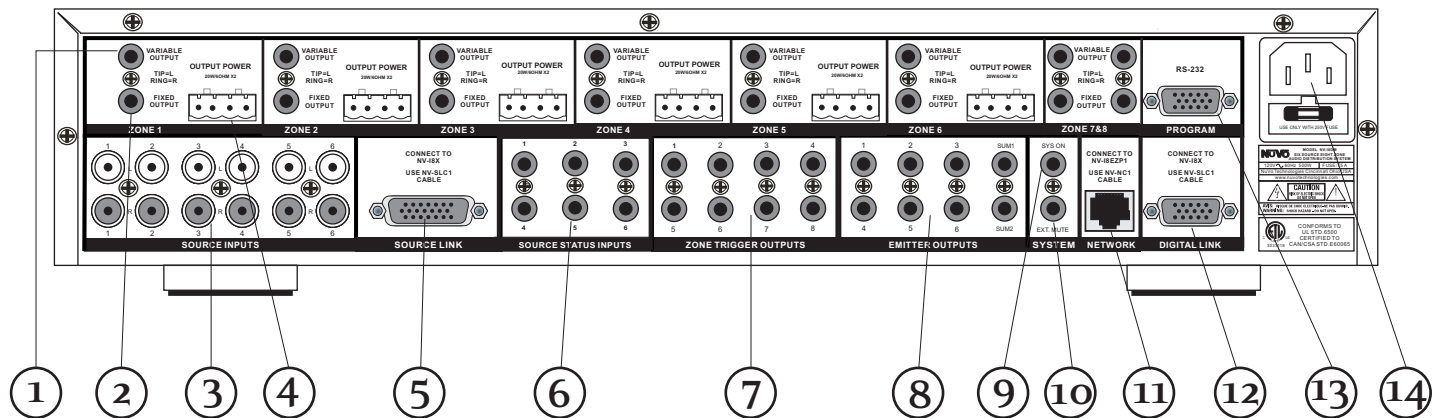

1. **Variable Lineouts:** These preamp lineouts are used for sending an audio signal to an external power amplifier. This is useful for large areas that require additional pairs of speakers. Use the variable output when you want the additional amplifier to be controlled by the zone's Display Pad.
2. **Fixed Lineouts:** These preamp lineouts are used for sending an audio signal to an external power amplifier when additional speakers are needed. This output is constant, so an amplifier connected to it will not change volume with that zone's Display Pad.
3. **Source Inputs:** The Grand Concerto will accept up to six audio sources. These are connected to the Grand Concerto amplifier with standard stereo RCA cables.
4. **Speaker Output:** Six of the Grand Concerto's eight zones are amplified. These outputs accept 16-gage, two-conductor speaker wire and provide 40 watts per channel of power.
5. **Source Link:** This connection is used in conjunction with the Grand Concerto Expander System to create 16 total zones. The source link cable is supplied with the Expander System.
6. **Source Status Inputs:** These optional inputs can be used to monitor source power status. This is useful when using a macro string of commands to prevent turning off a piece of equipment that is already on and vice versa.
7. **Zone Trigger Outputs:** These 12-volt outputs can be used to trigger an external device, such as an auxiliary power amplifier, for use in a specific zone.
8. **IR Emitter Outputs:** IR signals received from the keypads are passed through the IR outputs to the source equipment using the supplied IR emitters. Outputs 1-6 are routed to the corresponding sources, and the SUM outputs 1 and 2 are common and will pass all IR signals.
9. **SYS. ON:** This is a constant 12-volt output for turning on external equipment.
10. **EXT. MUTE:** This input is designed to temporarily mute any audio playing through the system when the doorbell or phone rings. This works in conjunction with the NuVo NV-M1 mute interface accessory. It also acts as a mute for whole-house paging through a phone system when set for this function in the Configurator software.
11. **Network Input:** This RJ45 connection is the input for all zone information coming from the Grand Concerto Control Pads. The connection is made using the Network Cable supplied with the package.
12. **Digital Link:** This connection is used in conjunction with the Grand Concerto Expander System to create 16 total zones. The Digital Link cable is supplied with the Expander System.
13. **RS232:** The bidirectional RS232 is a serial communication port that allows the Grand Concerto System to be controlled by an external home automation device.
14. **AC:** A detachable power cord connects the system to an external AC power supply.

Grand Concerto Control Pad

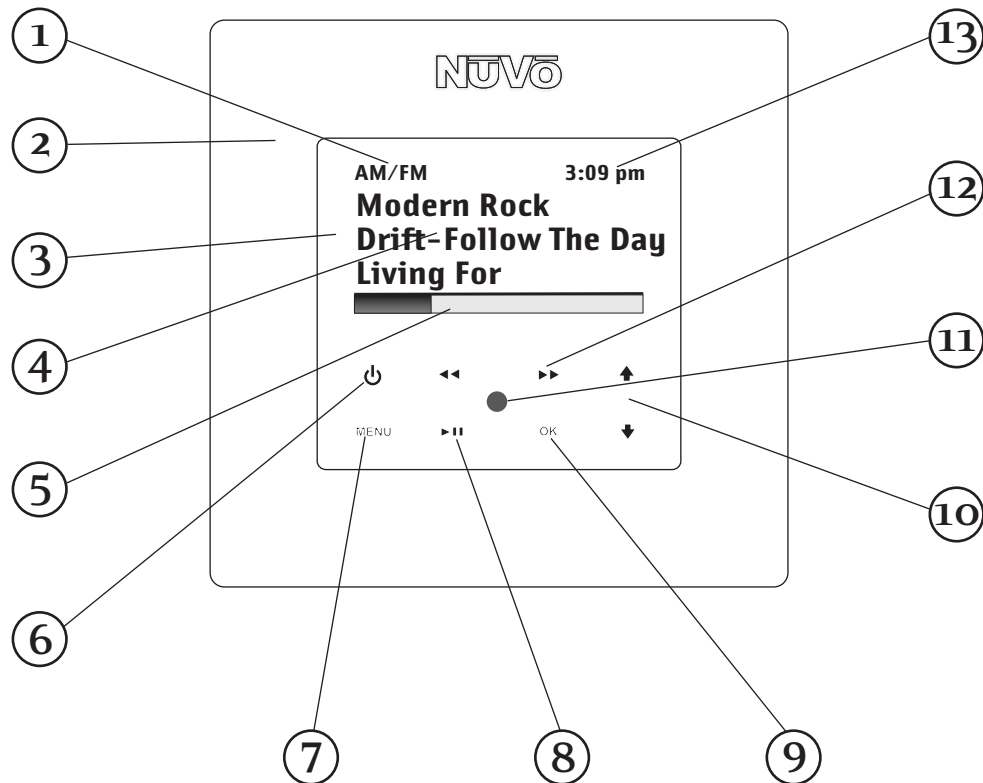

1. **Source indicator:** This indicates the current audio source playing in that zone. Source names can be customized in the Configurator software.
2. **Cover plate:** Each Control Pad comes with white, ivory, almond, and black trim plates that attach magnetically to the face of the keypad.
3. **OLED Display:** The organic light emitting diode display is a highly functional multi-line display.
4. **Now Playing/Menu Display:** This portion of the display serves two functions. In normal operation, it indicates the artist, station, metadata, and other source information.
5. **Volume Level Indicator:** This bar graph indicates the audio volume level when the Control Pad is in normal play mode.
6. **Power:** This button turns the local zone on and off and turns all zones off simultaneously.
7. **Menu:** Menu serves as access to music browsing, presets, and favorites, as well as specific zone-setting parameters.
8. **Play/ Pause:** This button serves as a general stop and start button for each of the sources.
9. **OK:** The OK button also serves a dual function. In normal play mode, it scrolls through the available audio sources. In menu mode, it is used to select the highlighted menu item.
10. **Arrow Up and Down:** These arrows have a dual function. In normal play mode, they control volume level up and down. In menu mode, they scroll up and down through menu selections.
11. **IR Receiver:** The Control Pad has a built-in IR receiver for complete wireless control of all the audio source equipment.
12. **Forward/Reverse:** This is an IR programmable button for simple source transport. Typically it would track forward or back or tune up and down.
13. **Time:** A feature of the Grand Concerto System is the ability to display the current time on each of the Control Pads.

Grand Concerto RC1 Remote Control

1. **Power:** Each zone can be turn on and off, or all zones can be turned off with this button.
2. **Volume:** This actually serves to functions. In normal operation mode, it is a volume control, but when you are using the menu features of the Control Pad, it allows scrolling up and down.
3. **Function Buttons:** These buttons allow for one-button macro commands.
4. **Forward and Reverse:** These IR programmable buttons are designed for forward and reverse functions.
5. **Favorites:** A function of the Grand Concerto System is the ability to access user defined favorites for easy access. The first twelve are directly accessible using the RC1 Favorites buttons.
6. **DISP:** This button allows access to the Display dim menu available at each Control Pad.
7. **Function LED:** This LED (Light Emitting Diode) lights to indicate a button push.
8. **MUTE:** The RC1 remote provides a discrete mute function to quickly silence the zone's output.
9. **SOURCE/OK:** This is another dual function button. In normal playback mode it scrolls through the sources, or in menu mode it selects a highlighted menu choice.
10. **Play/Pause:** This IR programmable button toggles between the play and pause functions of the chosen source. When using the T2 Tuners, this button toggles through the Tuners receive modes.
11. **MENU:** This button enters the menu features of the Control Pad. One in Menu mode the Volume up and down buttons scroll through the menu choices.
12. **Sleep:** This allows access to the sleep timer mode.
13. **Dynamic Groups:** A unique function of the Grand Concerto System is the ability to create temporary zone groups using the G1 and G2 buttons. This is useful if you wish to listen to a single source in multiple zones.

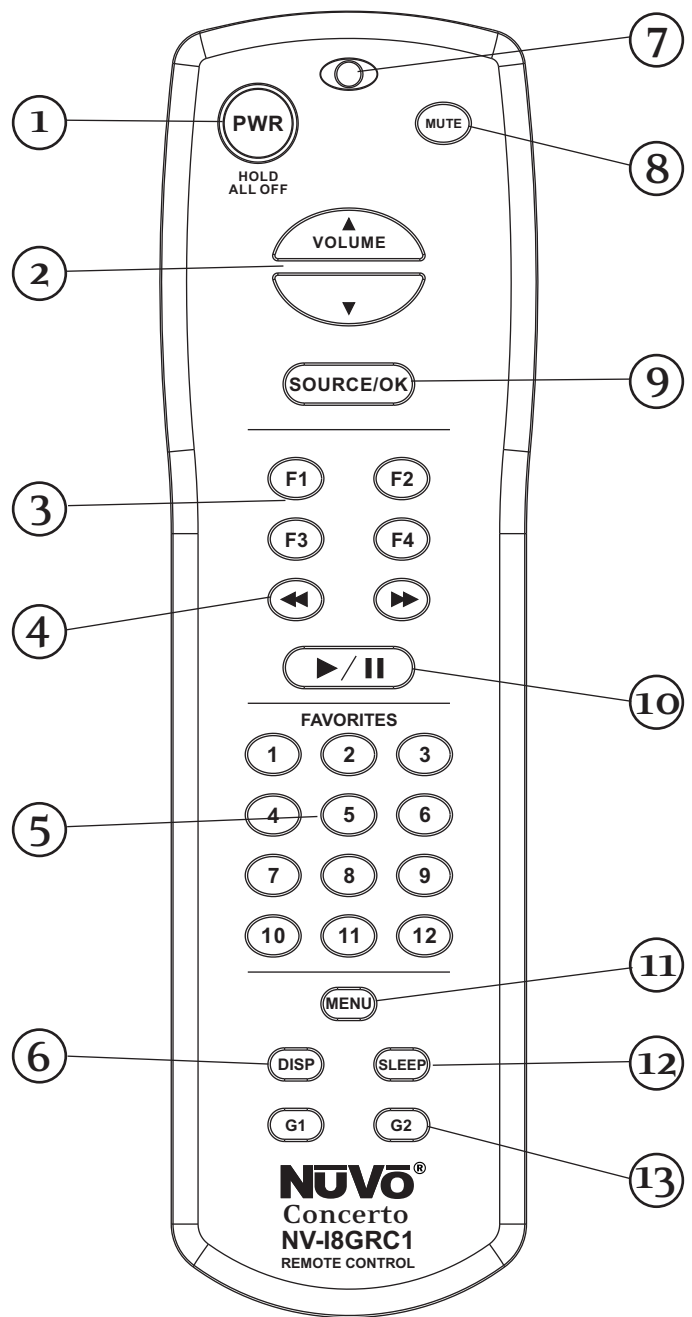

Installing the Grand Concerto System in Your Home

I. Prewire

The Grand Concerto System uses CAT5 cable for keypad control and either two or four-conductor 16-gauge speaker wire. All the wire is "homerun" from each zone to the location of the Grand Concerto amplifier and Audio Source equipment.

Complete CAT5 Crimping Instructions

The NuVo audio systems require CAT5, unshielded, twisted pair (UTP), for communication between the keypads/Display Pads and the main amplifier unit. Each end of the wire is terminated with an RJ45 connector.

The Grand Concerto System can accommodate 2,000 total feet of CAT5 cable. For the most reliable operation, it is best that no single run of CAT5 exceeds 250 feet.

The correct wiring scheme for the CAT5 cable is standard EIA/TIA 568A. Properly terminating the CAT5 cable is crucial for the operation of the system. It is very important to use a good quality crimp tool, and test each end to end run with a CAT5 wire tester to insure that your system operates flawlessly, fig.1.

Step-by-Step Crimping Instructions:

1. Strip a 2 to 3 inch portion of the insulation, exposing the 4 twisted pairs.
2. Untwist the wires and fan them out individually. Arrange the wires into the correct color scheme as shown in Fig. 1.
3. Flatten the wires in their correct order, and trim them evenly across the top. Most crimp tools have a wire trimmer built-in. It is best to trim the wires to about 1/2" in length.
4. While holding the wires flat between your thumb and forefinger, insert the wires into the RJ45 connector, so each is in its own slot. Push the wire into the RJ45, so all 8 conductors touch the end of the connector. The insulation jacket should extend beyond the crimp point of the RJ45.
5. Insert the RJ45 into the crimp tool receptacle and squeeze the tool firmly. Note that a ratchet type tool should tighten down until it no longer clicks.
6. The RJ45 should be firmly crimped to the CAT5 insulation. It is necessary that the color scheme be repeated identically on each end of the wire.
7. Test each termination with a CAT5 Tester before completing the installation.

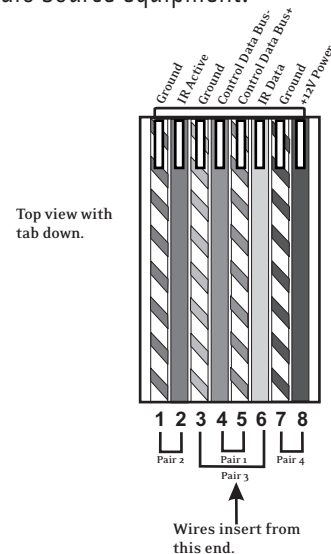
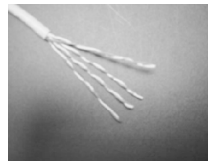

Fig. 1: EIA 568A wiring scheme for CAT5 Cable Pin #

1. Green Stripe
2. Green
3. Orange Stripe
4. Blue
5. Blue Stripe
6. Orange
7. Brown Stripe
8. Brown

Note: Colors listed as "stripe" are a white wire with a colored stripe.

Step 1



Step 2



Step 3



Step 4



Step 5



Step 6

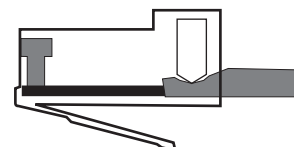

II. Terminating the Speaker Wire (fig. 2)

All the NuVo systems operate across a "homerun"-wiring scheme using Cat-5 for the zone keypad control communication, and a separate run of speaker wire for each zone from the speaker outputs to the zone speakers. We suggest 16-gage 2- or 4-conductor speaker wires.

The speaker wire termination is done using a modular "Euro" connector. Each conductor is screwed down to the connector block and plugged into the appropriate speaker output on the back of the amplifier. The proper termination is Left channel: - and +; Right channel: - and +.

III. Installing the Grand Concerto Amplifier

System setup works best when the amplifier is placed in the same location as the audio source equipment. This is typically in an audio rack, entertainment center, or a closet dedicated to housing the home audio/video equipment.

The amplifier should be plugged in and the power button on the front panel should be depressed before proceeding with the rest of the installation. This activates the internal protective circuitry of the Grand Concerto System.

IV. Installing the NV-18GEZP EZ Port (fig.3)

The EZ Port is a multi-connection hub designed to accept all the Cat-5 wires from the keypads in the system. The location of the EZ Port should be determined by the location of the Grand Concerto amplifier. It is best to place in a wall behind the amplifier that would be easily accessible if necessary.

The EZ Port fits easily in any dual-gang-size, low-voltage ring with an open back. These are often referred to as "mud rings." Simply plug the terminated Cat-5 wires into any of the 20 available jacks on the back of the EZ Port. The order in which the individual Cat-5 wires are plugged in is not important, although it is strongly recommended that you label the Cat-5 with the appropriate zone number for future reference.

Once you have plugged the Cat-5 wires into the EZ Port, screw the EZ port into its construction bracket using the supplied mounting screws.

Fig. 2

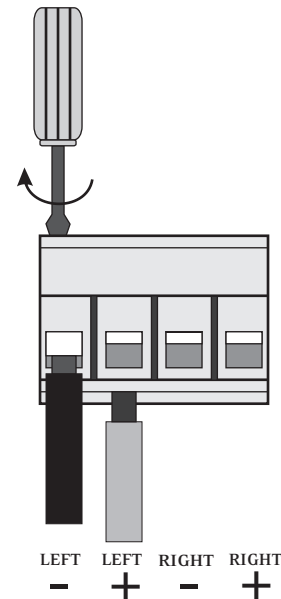
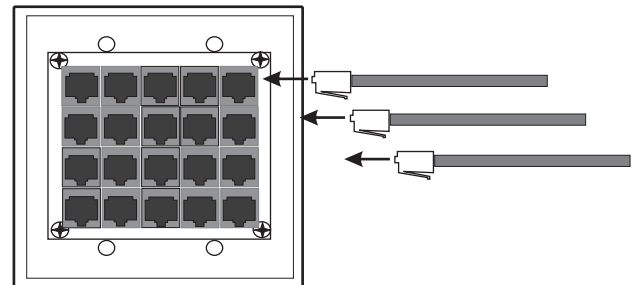

Fig. 3



V. Connecting the EZ Port to the Grand Concerto Amplifier (fig. 4)

When the EZ Port is installed in the wall, the only part visible should be the faceplate and four RJ45 jacks. The supplied pre-terminated network cable can then be plugged into one of the six available jacks and into the Network connection on the back of the Grand Concerto Amplifier. Any Cat-5 cable terminated using 568A or 568B network wiring will suffice should you need a longer connection. Remember, it is important to terminate the cable the same way on both ends.

Fig. 4

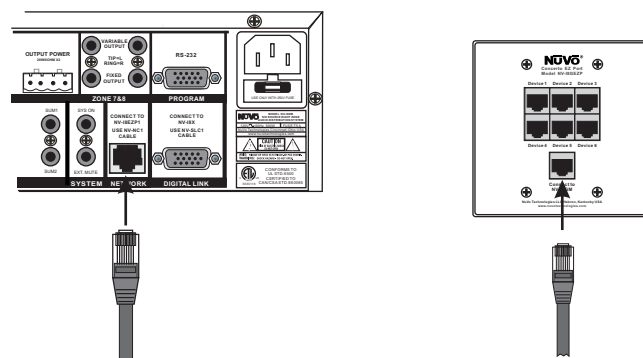

VI. Attaching Audio Source Equipment to the Grand Concerto Amplifier (fig. 5)

Each piece of audio equipment is connected to the Grand Concerto amplifier with standard stereo RCA cables. Attach an RCA cable to the corresponding audio output on the source equipment and to the desired source input on the back of the Grand Concerto amplifier. The numbered input for each source is important in the configuration of the system. This will be covered in detail in the Grand Concerto Configurator portion of this manual.

Fig. 5

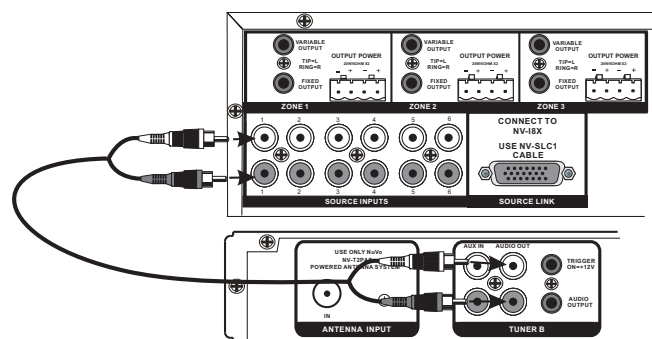

Attaching the NuVo T2 Tuners and M3 Server

A feature of the Grand Concerto System is its ability to automatically communicate with the T2 AM/FM and Satellite Tuners and the M3 Audio Server. The communication happens through the EZ Port connection hub, across a communication protocol called NuVoNet. Although software programming is not necessary for this function, configuring the installation through the Configurator Software prior to installation has distinct advantages, see **X. Grand Concerto Configurator Software**.

When the T2 Tuners or M3 Server are plugged in for the first time, they will display a prompt to select a source input number for the Grand Concerto. For NuVoNet to communicate properly, you should have already connected the NuVoNet components to one of the six "Peripheral Device" inputs on the face of the EZ Port.

T2 Tuners

Each of the T2 Tuner components actually houses two individual AM/FM or Satellite receivers, which have their own display on the front panel. Once the T2 is plugged in and the NuVoNet CAT-5 is connected to the EZ Port and initial display, **OPERATING MODE** will appear for each tuner. Below this, the choices are **STAND ALONE, SOURCE 6, SOURCE 5, SOURCE 4, SOURCE 3, SOURCE 2,** and **SOURCE 1**. Stand Alone is automatically highlighted at initial startup. Selecting the appropriate Concerto source input is accomplished by turning the Select knob for each tuner counter-clockwise until the desired source input number is highlighted. It is selected by pushing the Select knob. Once this is done, the Grand Concerto NuVoNet will recognize that source.

M3 Server

At initial startup, the front panel display will prompt with **OUTPUT 1: PRESS OK TO SELECT NUVONET SOURCE**. When **OK** is selected, the top line of the display will read **OPERATING MODE OUT 1**. Below this the three available lines will display **STANDALONE, SOURCE 1, SOURCE 2 . . .** as you scroll using the down arrow button, **SOURCE 3, SOURCE 4, SOURCE 5**, and **SOURCE 6** will appear. Highlight the appropriate choice and press OK to select. This will set the first channel music output. You will then be prompted to repeat for these steps for the remaining two channels.

VII. Connecting the IR Emitters for Third-Party Source Components (fig. 6)

IR commands for the source equipment are transferred from the Grand Concerto amplifier to the source equipment using the mini IR mouse emitters. Six of these are supplied with your Grand Concerto System. The emitter is plugged into the corresponding source IR output on the Grand Concerto and then placed over the IR receiver window on the source component. The IR outputs are individually routed to sources 1-6.

The two SUM outputs will flash any IR command that is sent from any of the zones. This is most commonly used with an IR blaster designed to flash IR commands to a variety of components.

VIII. Source Status Inputs (fig. 7)

The source status inputs can be very useful for monitoring the power status of your audio sources. Some equipment uses "toggling commands" for powering on and off (that is, the commands for on and off are not separate, discrete commands). This situation is typically confusing when using a single button to initiate to a piece of source equipment a string of commands that includes power on. With "toggling" equipment, if the unit is already on, moving the button will inadvertently turn it off. The source status inputs give the Grand Concerto System the ability to sense that the source equipment is on so it can automatically bypass that command.

Fig. 6

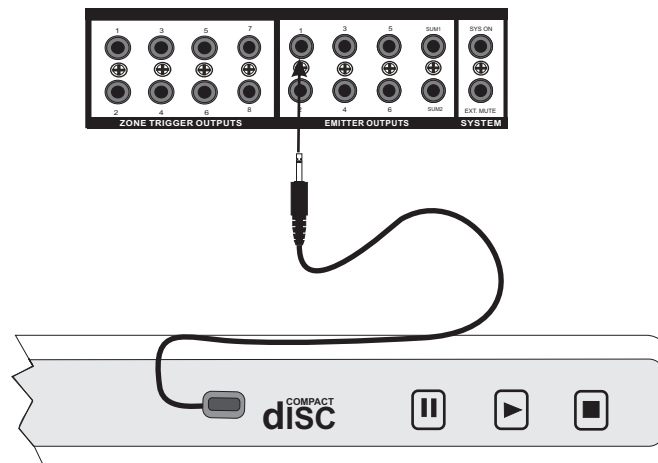
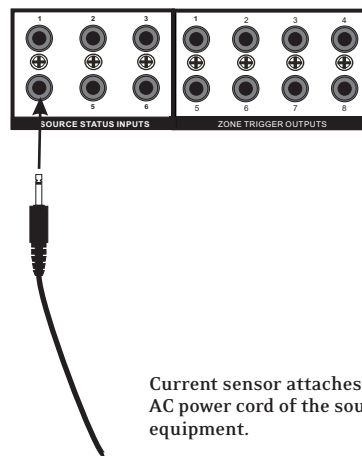

Fig. 7



Current sensor attaches to the AC power cord of the source equipment.

Using these inputs requires an AC power-sensing module. These are readily available from electronic accessory manufacturers and typically attach to the AC power cord of the desired source equipment. The connection at the back of the Grand Concerto is a mono 1/8" jack. Once this is in place, the Grand Concerto System will sense the amount of AC current being drawn by the source equipment.

IX. Expanding Grand Concerto to 16 Zones (fig. 8)

Eight additional listening zones can be added to the Grand Concerto System using the Grand Concerto Expander package. The expansion is easily done using the Source Link and Digital Link multi-pin outputs on the Grand Concerto main amplifier (NV-18DMS).

The necessary cables for this are supplied with the Expander package. No other connections are necessary except the AC power cord and the additional speaker terminations. The additional Cat-5 wires for the zones 9-16 plug into the Grand Concerto main EZ Port.

Fig. 8

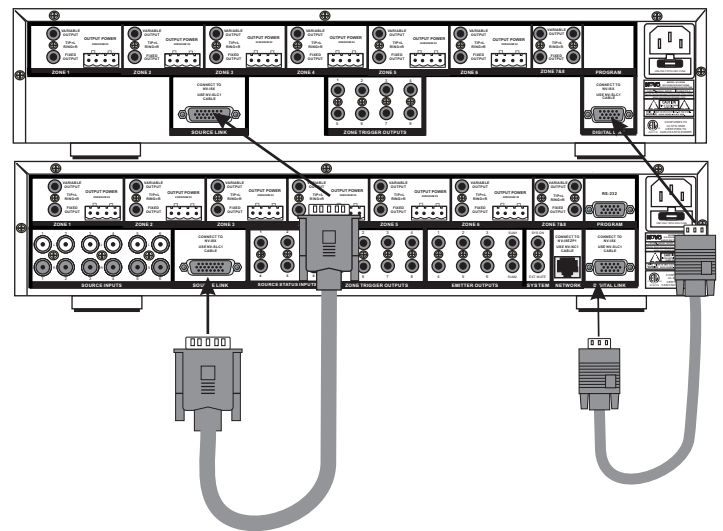

X. Using the Grand Concerto Configurator Software

The following section requires the NV-18DLS IR Learning Station and Configurator Software. This is available as a package from NuVo Technologies or any Authorized NuVo Distributor. The Configurator software is a PC program designed to run with Windows 2000, XP, and XP Pro.

1. Main Startup

The Configurator is a tabbed Wizard-style interface designed to sequentially walk the installer through the system setup. When the program is launched, the Start tab is highlighted. This gives three choices for beginning a configuration. You can create a new file, open an existing file, or retrieve an existing file from a configured Grand Concerto System. Once configured, the finished program loaded into the Grand Concerto main amplifier can always be retrieved via the RS232 port and edited.

Once a configuration file has been opened, you can then click on the next button to continue. The Configurator will not let you continue beyond Start without either creating a new file or opening an existing file. It will also prevent moving forward through any of the tabs until the necessary information is completed in any one of the tabs.

1. Main Startup

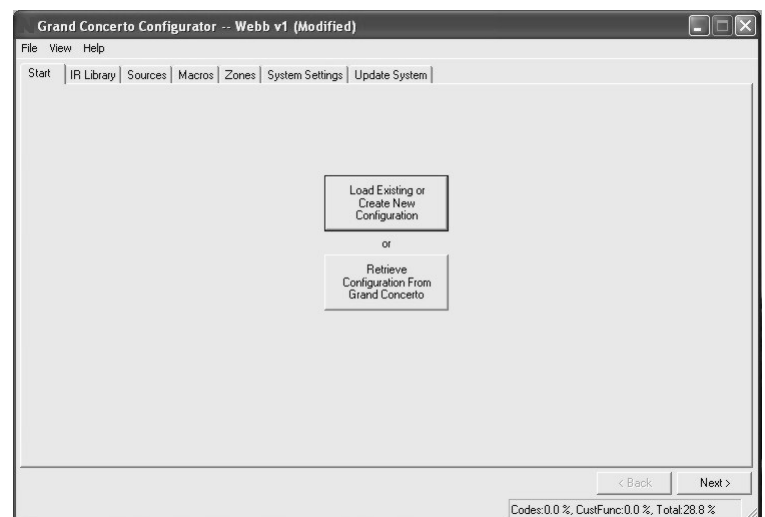

1.1 Open or Create Grand Concerto Configurator File

When you click on this button, the program goes to a Config. File. There you can either open one of the existing configurations or specify the name of a new file. Configurations are saved with a .cfg extension.

1.1 Retrieve Configuration from Grand Concerto

To retrieve a configuration from an existing Grand Concerto installation, launch the Configurator software. Make sure your computer is connected to the RS232 port on the back panel of the Grand Concerto amplifier. The Startup screen has two buttons. The first is used to open an existing configuration or to create a new one. The second asks to "Retrieve Existing Configuration From Grand Concerto." When you click on the "Retrieve" button, a progress window will appear.

If you have this configuration already stored on your computer's hard drive, you will see a dialog box asking if you wish to overwrite the existing file. If this file is not stored in your computer, this box will not appear.

2.1 IR Libraries

The IR Library is a list of available components and their IR function codes. The Configurator software stores captured IR codes in a single directory. Once captured or downloaded, the Configurator software will permanently store it as an .irc file.

2.1 IR Libraries

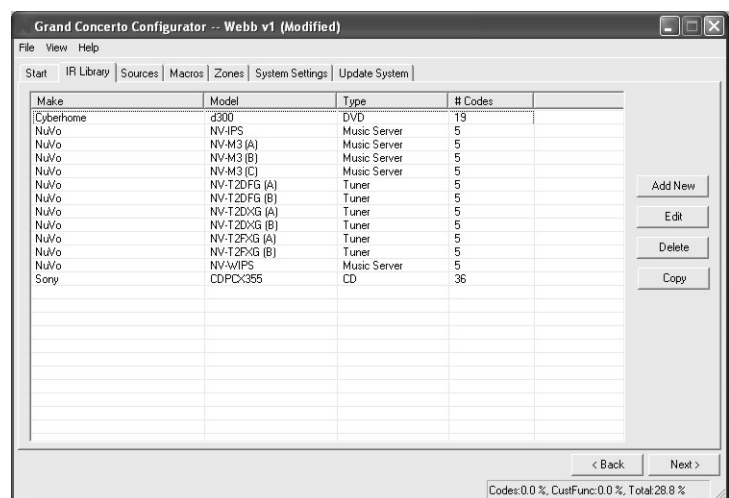

1.1 Open or Create Grand Concerto Configurator File

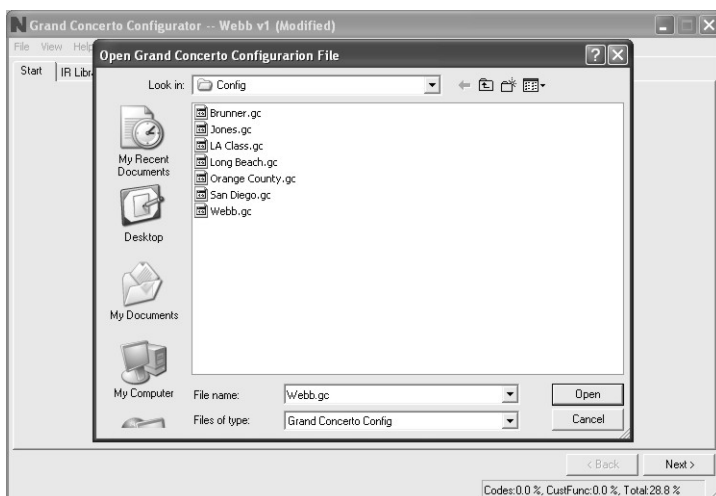

2.2 Adding a New Component to the IR Library

New component IR files are easily added by clicking on the Add New button. This brings up a new window titled Add New Component. In this window you must first enter the manufacturer name and model. The Type drop-down menu contains a large list of components. Each is a template of common functions for that type of equipment. Clicking on the type that matches the component will add the type name in that field. If desired, you can add a type name that is not in the drop-down menu.

Clicking on OK will automatically add the selected component and associated functions to the IR Library.

Using the IR Learning Station Interface (fig. 9)

To record new IR codes, you will need the IR Learning Station Interface. The IR Learning Station Interface is a powerful tool for setting up new IR Libraries for use with the Configurator Software, and is part of the IR Learning Station Package. Capturing function codes and adding them to the component IR Library is an easy process.

The Interface box is connected to your computer using one of the RS232 connection cables provided with the IR Learning Station package. Note that in many cases, personal notebook computers do not have aDB9 serial cable. In this case an RS232 to USB dongle cable will be necessary.

The back panel of the Interface box has two IR outputs for testing purposes. You can use the included IR emitter and attach it to the IR window on the face of the source component, or to the built-in IR blaster, which, when aimed at the source equipment, will fire the IR command.

2.3 Recording IR codes

When a new component is added to the IR Library, it is necessary to record the IR codes associated with each function. To do this, connect the Learning Station Interface as described above. Double-click on the desired component from the IR Library page. This will open the IR Library Editor. This window lists the complete set of functions for that type of device.

To initiate the IR recording process, you can either double-click on a function to be recorded or highlight the function and click on the Record button. This will open the IR Library Record window. The window will indicate that the Configurator is "Waiting for IR Communications." To record a new code, simply point the component's remote control at the IR receiver on the NuVo IR Learning Station Interface. The first time you enter a code, the Configurator determines if it is a "toggling function," which means that the remote actually sends two commands back-to-back. This requires that the function button be pressed four times in succession.

Fig. 9

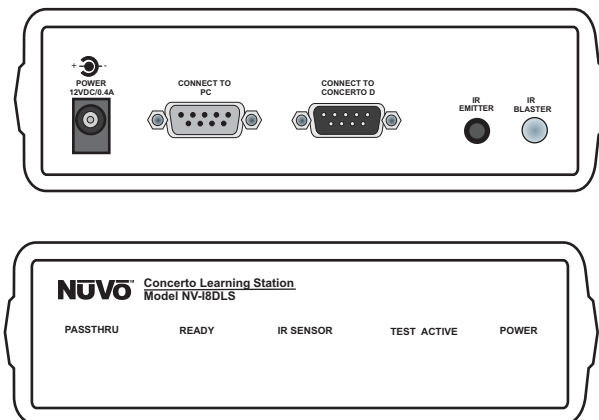

When the remote code is entered, the IR Library Record window will go from yellow to green and indicate that the capture was successful, and it will then return to yellow. Repeat this procedure three more times until the desired code is added to the IR Library Edit window. You will now see the number of code repeats and the duration of the code. A normal non-toggling remote will require two button pushes to successfully record a command, while a toggling remote will require four button pushes for each command.

If there is an error in recording the code, the display in the Record window will indicate that there was a communication error. If this occurs, click on the Record button and reenter the code.

2.3 Recording IR Codes

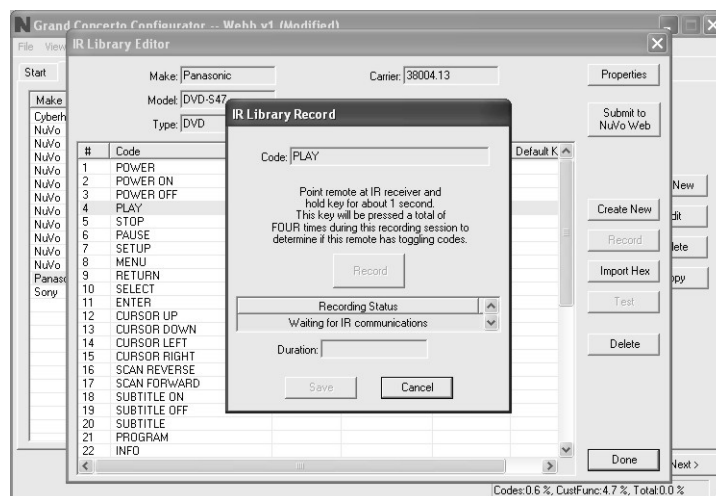

2.4 IR Library Default Key Assignment

Once the desired codes are added, assign them to the appropriate key on the Display Pad. To do this, right-click on each code and select "Keys." This opens a drop-down menu of the possible key selections for the Grand Concerto Display Pad. Select the appropriate key for that command and the Configurator will add it to the Default Key field for that command. Keep in mind that the Grand Concerto Control Pad has only five IR assignable buttons, so button control is limited. More capability for control can be incorporated in the macro tab covered later, and can then be added to the menu capability of that source.

Once this sequence is completed, proceed to the next function command, and repeat the above steps. When you have assigned a default key for each IR, click on "Done" and that component's IR Library is complete.

2.4 Library Default Key Assignment

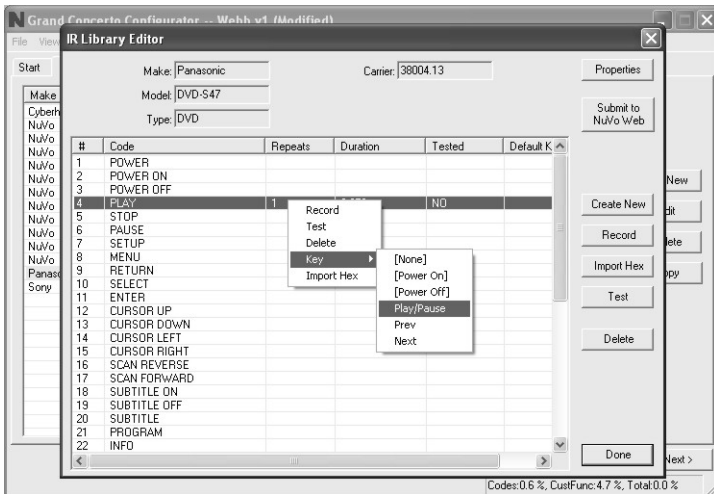

2.5 IR Library Test

An important feature of the Grand Concerto Configurator is the ability to test each IR code as it is added to the IR Library. This insures that every code will work reliably.

When a new code is added, while it is still highlighted, click on the test button. This will open the IR Library Test window. Make sure that the IR Learning Interface box's IR emitter is either facing the IR receiver window of the source equipment or an IR emitter is plugged into one of the two IR emitter outputs and affixed to the IR receiver window of the source equipment. Clicking on the test button will cause the IR Learning interface to emit the code. The source equipment should respond appropriately to the command if it has been stored correctly. A test result box will open where you can record yes or no to the test. Three successful test results are required before the "Passed" count turns green. Clicking the "OK" button will save the results in the IR Library. The "Tested" column for that command will show the number of successful tests performed.

Although not required, testing each code is highly recommended.

2.5 IR Library Test

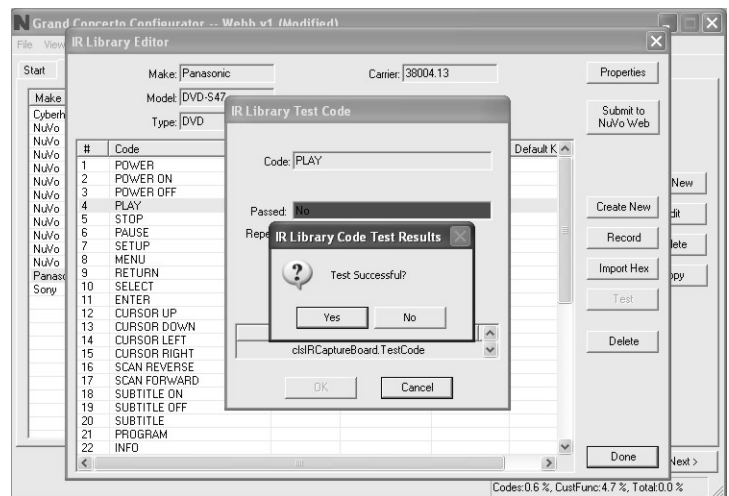

2.6 Adding a Function Code

If a required IR code is not in the list of codes, it is possible to add a code to the list by clicking the "Create New" button. The pull-down menu contains a list of all standard IR codes. A name not found in the list can be typed in, but it is recommended that you use the names provided in the list. This conserves memory in the Grand Concerto. Clicking on the "OK" button proceeds directly to the IR recording process.

3.1 Select or Edit Source

Double-clicking on a blank source will open the "Select Source" window. This window assigns the appropriate source number input. The "Display Name" is the text that will be read on the Display Pad when that source is selected in any zone. The display name can contain only capital letters, numbers, and some punctuation. If an invalid key is typed, it will be ignored.

The "Make" field defines the manufacturer of the equipment. A drop-down menu allows you to choose a source from the IR Library. The "Model" field provides a drop-down menu that allows you to choose the specific piece of source equipment from the selected manufacturer.

An important feature of the "Select Source" window is the "Gain" level control. Different pieces of source equipment tend to have different levels of audio output signal. This slider control allows you to compensate for equipment that has an inherently lower volume level. By using this adjustment, when switching between sources, relative volume levels remain constant.

When the appropriate information has been completed, click "OK." This will add the updated source information to the "Source" window. When all the desired sources have been defined, go to "Next" and proceed to the "Macros" setup.

2.6 Adding a Function Code

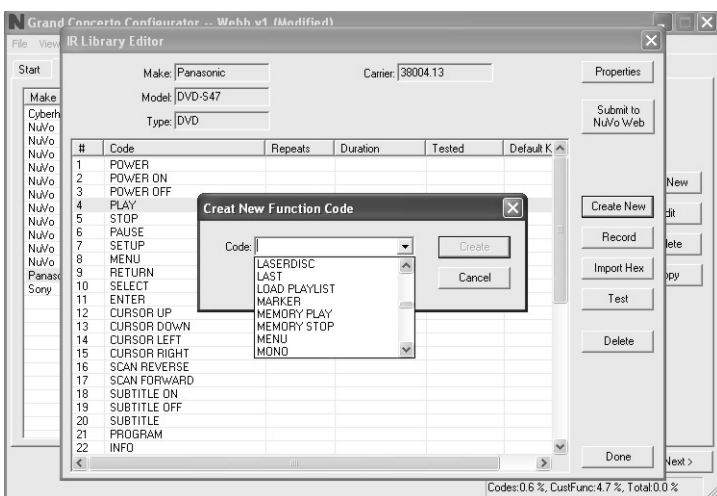

2.7 Cleaning Up an IR Library

Unused IR codes can be deleted from the list by highlighting the code and either clicking the "Delete" button or right-clicking and selecting "Delete."

When you are finished editing the library, select "Done."

3. Defining Sources

The "Sources" tab allows you to define the source component attached to each of the six source inputs. All six sources are not needed, but at least one source must be defined.

3.1 Select or Edit Source

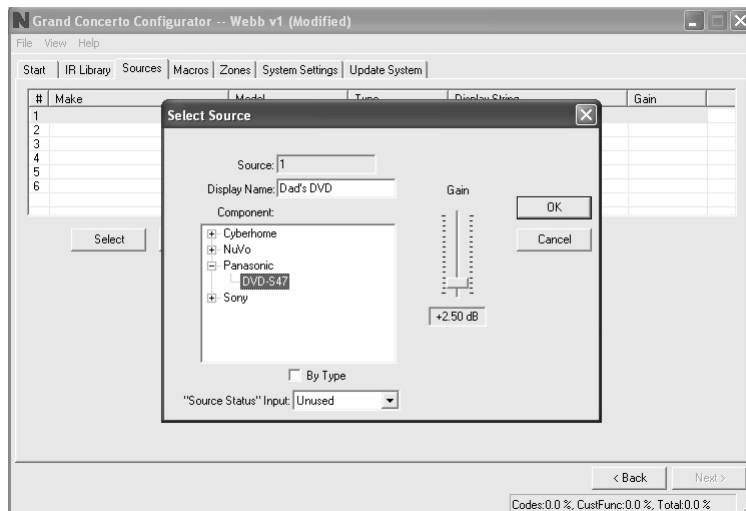

4. Macros

Each source defined in the "Source" step has a separate Control Pad definition. The "Source to View" pull-down menu provides the display name given to each source. Using the "Next" and "Back" buttons will automatically cycle through all defined sources.

An important feature of the NuVoNet Suite is the communication with each Control Pad within the installation, which eliminates the need for Macro Definitions. However, if you do want to create specific strings of IR commands or use the IR libraries of third-party source equipment to setup functions within that source's Menu on the Control Pads, this is the place to do that.

If the component had default keys defined in the IR Library, single IR code macros will be automatically created for each key. Hovering the mouse over each key in the Display Pad picture on the left side of the screen will bring up a tool-tip displaying the name of the macro assigned to that key. Clicking on the key highlights the macro on the right side of the screen.

Double-clicking on a key in either display will begin editing the macro associated with that key.

4. Macros

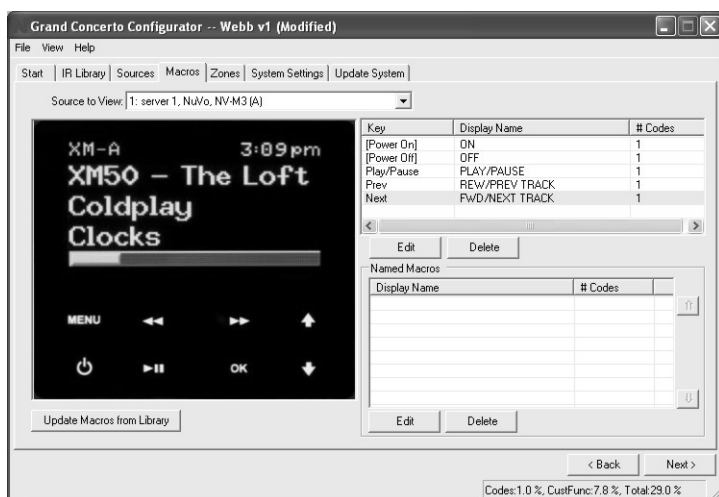

4.1 Edit Macro Definition

The Macro Definition window has two separate points of definition on the right side of the screen. The top section allows a string of commands to be associated with one of the five IR programmable buttons. The bottom section automatically places the commands in the menu selections at the Control Pads. Examples of this use would be specific disc selection on a multi-disc changer or specific station tuning for satellite or cable receiver boxes.

The tree in the left-hand window displays all available IR codes from the library. The tree is automatically expanded to show the codes from the component associated with the source.

Each macro has a "Display Name" that is used to describe the macro. Before a macro can be saved, the name of the macro must be established.

4.1 Edit Macro Definitions

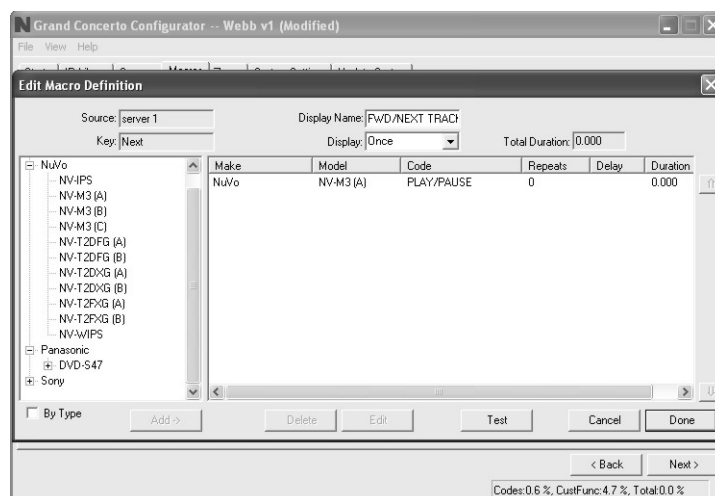

4.1.1 Adding Codes to a Macro

A code is added to the macro by double-clicking on the green IR code name in the library to the left. That code will then be automatically added to the macro string to the right. Up to 100 codes can be added to a single macro.

4.1.1 Adding Codes to a Macro

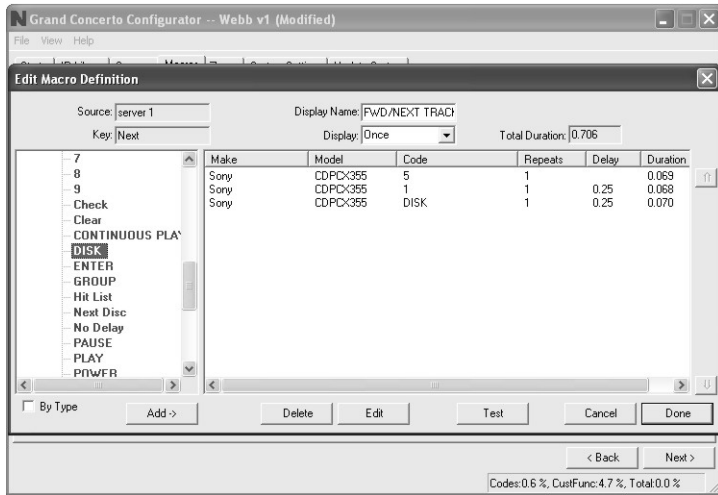

4.1.2 Editing Codes in a Macro

Double-clicking on a macro step on the right side will open an "Edit Macro Code Settings" window. This allows you to change the delay time before the command is issued. The default delay is .25 seconds. This can be increased by .25-second increments up to 30.5 seconds. Often a command requires mechanical movement in the source equipment and, therefore, the delay is important before initiating the next command.

The number of repeats for each command can also be changed. This is equivalent to pushing and holding the button on the remote control.

4.1.2 Editing Codes in a Macro

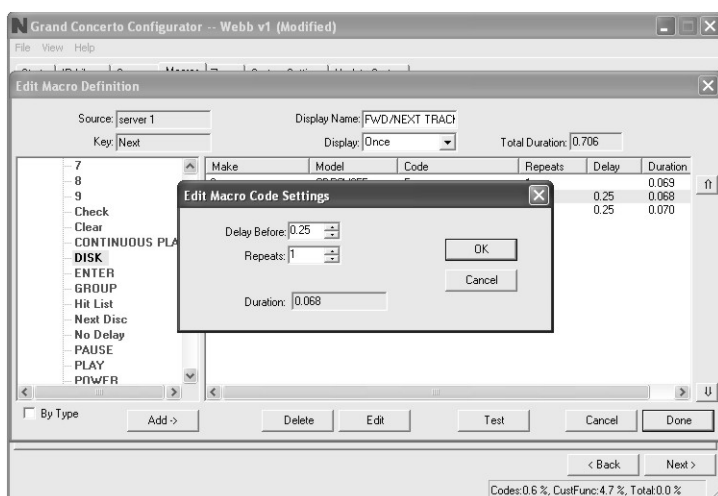

Re-Ordering Macro Codes

After a code is added to a macro, highlighting a code and pushing the \uparrow or \downarrow button can reorder the codes.

Macros (updated)

After editing a macro, the macro list is updated to show the number of IR codes and the display name.

Note that the Macro tab has an additional button at the bottom that says "Update Macros From Library." If codes were edited in any way in an IR library after a source has been defined in the Source tab, this button will automatically pull those changes into the Macro Definition window.

5. Zones

Up to 20 zones can be defined with the Grand Concerto. Each zone can be defined with unique properties.

You will notice that the zone tab contains 20 entries for zone Display Pads. The system can accommodate a total of 20 Display Pads by using the slave function in the "Edit Zone Properties" window. A slave Display Pad is homerun to the EZ Port, but automatically shares the same functions and works in tandem with the main zone Display Pad. Up to three slave Display Pads can operate on a single zone.

5.1 Edit Zone Properties

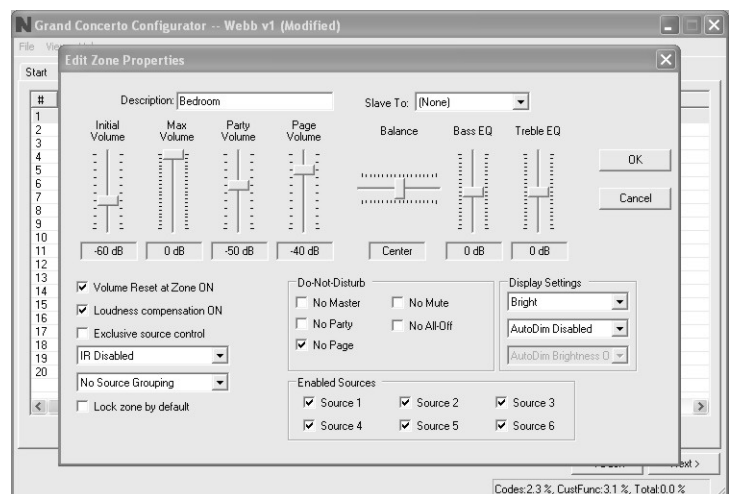

5.1 Edit Zone Properties

Double-clicking on a zone number opens the "Edit Zone Properties" window. Specific properties defining that zone are set here.

Max Volume: This allows the volume in a zone to be limited. This can be done either to avoid damage to low-power speakers or simply to prevent a certain room from being turned up too high (e.g., a teenager's bedroom).

Party Volume: This controls the reset volume level for each zone when the All On/Party Mode is initiated from any of the Control Pads. The range is -78dB to -30dB.

Page Volume: If you are using the paging feature of the Grand Concerto System, you can also set the specific volume level of the page zone by zone, by using this volume control. The range is -78dB to -30dB, with a default at -40dB.

Balance: The level of output to the left and right speakers is adjusted here. The default is center, but depending on the location of the speakers and the optimal listening area of the room, it may be advantageous to adjust the balance to either the left or the right.

Bass and Treble: Each of these EQ levels can be adjusted individually. The range is -18dB to +18dB.

Volume Reset at Zone ON: A zone-specific feature is the ability to have a zone automatically reset to a low volume level when the zone is turned on. This check box initiates that feature and is tied to the Zone Reset Volume level set above it. If this box is not checked, the zone will turn on at the last volume level.

Loudness Compensation ON: This box defaults to checked and enables an automatic bass and treble boost when the zone is at a low listening level. This EQ gradually flattens out as the zone volume is increased. Unchecking the box turns this function off.

Exclusive Source Control: Checking this box gives this zone exclusive "do not disturb" control of any chosen source. Other zones will have the ability to listen to that source, but they will not have any specific function control.

Source Grouping: This allows for one zone to automatically listen to the same source as all other zones in the group. This is a very useful feature for a large open area where it is not practical for more than one source to be playing at one time. The advantage of the zone group is that each Display Pad within the group has the ability to turn on or off, mute, and control volume independently. This drop-down menu allows any zone to be assigned to a group, or as an individual zone with no group affiliation. Up to four distinct groups can be created.

IR Pass-through: Each zone Control Pad has an IR receiver for wireless remote control. By its nature, IR is susceptible to external interference. To account for this, there is specific IR pass-through settings for each Control Pad. **IR Disabled** turns off the IR receiver completely and eliminates any possibility of a competing light source. This is useful in an environment in which the Control Pad receiver is competing with overwhelming sunlight. This will prevent IR communication throughout the system and therefore, it is better to eliminate that light source. **IR No Pass-through** prevents third-party remote control commands from being accepted, but still allows the NuVo NV-18GRC1 remote control to operate the system. In some zones this is necessary when a third-party remote is often used to control a non-NuVo System source such as a TV. This would eliminate that remote control's commands from being received by the Control Pad and passed through to the source equipment.

Lock Zone By Default: This check box turns on a function that automatically prevents any functionality from the zone until the assigned security code is entered. Primarily, the function prevents an outside zone from being turned on except when the homeowner really wants to listen to it.

Do-Not-Disturb: This Section is used to lock out system-wide commands from a specific zone.

No Master: Master and Party refer to the ability to turn all zones on simultaneously. In some zones you may not want this function.

No Page: The Grand Concerto System is capable of paging through audio source input 6. This involves a phone system that has a paging audio output and a means to provide a voltage trigger. This is controlled using the Security tab to set the voltage trigger and utilizing the Mute Input, see Mute Input page, . This will be covered in the next tab.

Enabled Zone Sources: These allow individual sources to be turned off for specific zones. A source that is turned off will not display in that zone. This is particularly useful in preventing child access to a source dedicated to adult listening.

Display Settings: The overall brightness and AutoDim feature for each Control Pad are set using these drop-down menus. The first menu is the display brightness. The choices are **Dimmest, Dim, Not So Bright, Normal, Bright, Brighter, Brightest**. The second menu sets the duration for the AutoDim feature. These range from **AutoDim Disabled, 15 Sec up to 1 Hour**. The next menu sets a specific **AutoDim level**. **AutoDim Brightness Off removes all display and backlighting**. **Using AutoDim Brightness Low or AutoDim Brightness Medium** reduces the level of brightness, but does not make the Control Pad completely dark.

Slave To: This drop-down menu is used to assign additional "slave" Control Pads to a zone. Up to 20 Control Pads can be used in an installation. The EZ Port hub is equipped with 20 RJ-45 ports to accommodate all the system's Control Pads. This is a useful feature for large rooms where more than one Display Pad is desired. If slave Display Pads are used, we suggest that you disable the IR pass-through on those to prevent cross-communication. The Slave To function can also be used to tie two or more zones together under the control of a single Control Pad.

5.2 Zones (updated)

When the desired properties for each zone are set, click on OK. This will return you to the Zones tab. There you will see an updated list of the zones by the number they are assigned, as well as the specific parameters defined in the Zone Edit window.

Double-clicking on the zones will reopen the edit window, where any of the definition properties can be modified.

5.2 Zones (updated)

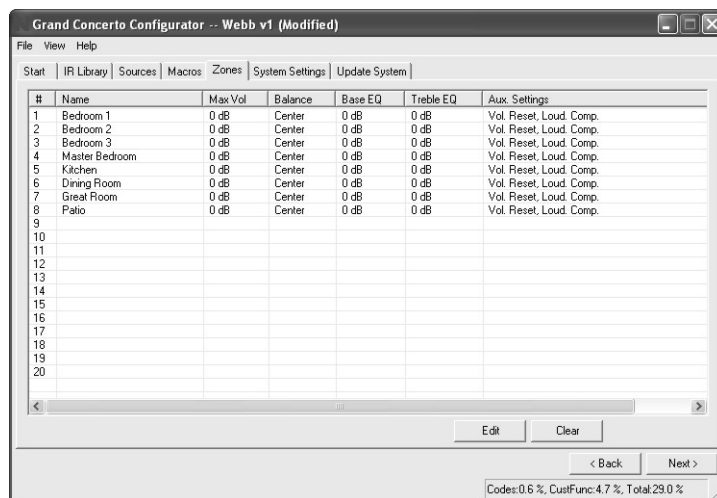

6. System Settings

This tab is used to define the way in which the External Mute input functions and for setting the zone lockout security code.

6.1 External Mute: System Mute Trigger

The Grand Concerto System has an accessory, the NV-M1 Mute Interface, which is designed to mute any music playing through the system when a doorbell or phone rings, see M1 Mute Interface. When setting the System Mute Trigger, set the mute input to respond to the contact closure provided by the M1.

6.1 System Mute Trigger

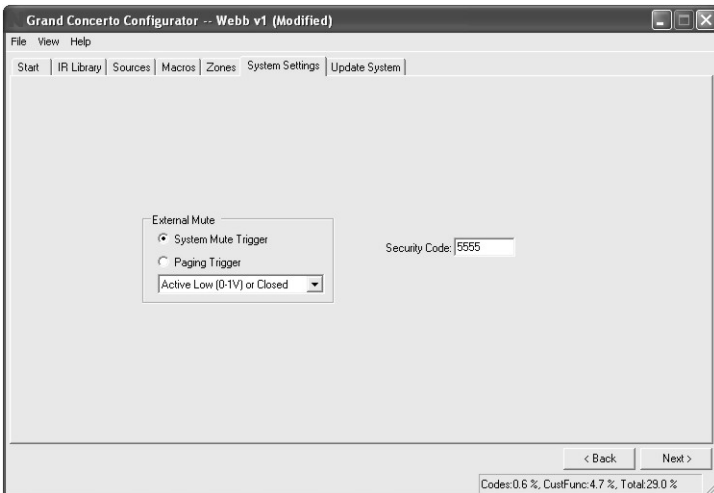

6.2 External Mute: Paging Trigger

The Grand Concerto System has a built-in solution for whole-house paging typically through a phone system. The Paging Trigger setting causes the system to mute across all the zones, and in turn, amplifies the page across all zones. Each Zone Edit utility in the Configurator software or the menu at each Control Pad offers the capability of setting the page volume in each zone.

6.2 Paging Trigger



7. Update System

The finished configuration is now ready to be downloaded to the Grand Concerto amplifier. While downloading, a progress box will show download progress. Once complete, the configuration is permanently stored in flash memory. Configurations can always be retrieved and edited at a future date.

7. Update System

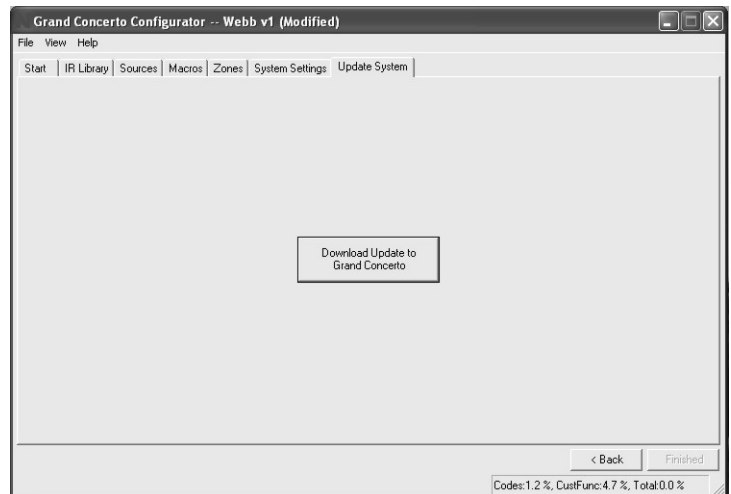

XI. Control Pad Setup

Factory-new Installation

The system should be programmed with the Configurator prior to setting up the Display Pads for the first time. The Grand Concerto amplifier should be placed in its permanent location, plugged in, and turned on. When a Display Pad is plugged in for the first time, the following sequence will occur:

1. When first plugged in, **Grand Concerto V. X.XX** where X refers to the current firmware version number loaded in the Grand Concerto main amplifier unit. The Control Pad will then go to the **Zone Selection** menu.
2. Press the Power Button to turn the Control Pad on. The display will flash the Grand Concerto and Version number screen and immediately go to **Zone Selection**. If you have loaded a configuration into the main unit, once in Zone Selection mode all the configured zone names will appear starting with the first. If you are setting the system directly out of the box, it will simply list generic **Zone 1, Zone 2,** etc., up to **Zone 20**. Setting the appropriate zone address is simply done by using the arrow buttons to scroll up or down to the appropriate zone and pressing the **OK** button.
3. The Control Pad will flash the version-number screen one more time and immediately turn off. When powered on, the addressed Control Pad will then go to the first established source.

At this point, the zone may be operated by the parameters set in the configuration. Zone settings may be modified using the MENU key.

Reprogramming the Zone Address

This procedure allows an addressed Control Pad to be moved to a new location. Within the main menu of each zone, go to **Setup**. Within the Setup options, scroll to **Advanced Settings** and to **Zone Number**. All the used addresses will be grayed out. Any available addresses will be accessible. Scrolling to **None** will erase the current address.

XII. Using the Control Pad's MENU Button

Menu gives access to specific music selection and control for each source, as well as zone- and system-setting capability. When the MENU button is pushed, the display goes to an eight-line screen labeled Main Menu.

MAIN MENU – At initial startup three menu items will appear. They are **Favorites, Sources,** and **Setup**, fig. 10.

Fig. 10

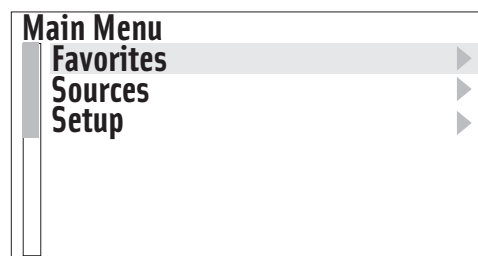

Favorites: Top-line favorites are global. Favorites or play lists set up with in Windows Media Player and synced with the NuVo M3 Server or within an iPod can be added to the Favorites list. Potential members of this list can also include station presets for the NuVo T2 or other sources such as satellite or cable. Assigning global favorites is done in the **Setup** menu.

Sources: This offers quick access to the six sources defined in the system. Third-party sources can be defined with a source name in the Grand Concerto Configurator software, or they are labeled by the system as a generic source number. –The NuVoNet sources have a predefined system name, fig. 11.

Fig. 11

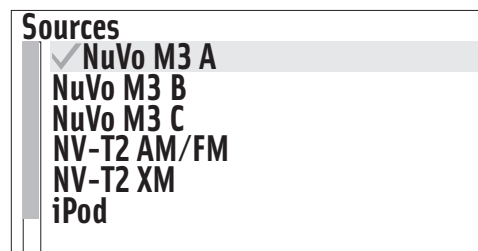

Setup: The Setup menu is for specific system setup. It consists of several subset menus. These are defined in the next section.

Favorites #1-12: Twelve global favorites can be defined for easy access from within the Main Menu. Any favorites, which include M3 and iPod play lists, tuner presets and specific disc selections can be selected in the Favorites setup and automatically added to the global list. The Grand Concerto Remote Control has a 12-button numeric keypad that provides direct access to the 12 assigned favorites. When a favorite is selected, the zone will automatically go to the appropriate source and music selection.

Zone Settings: This is the first menu option under Setup, fig. 12.

Balance: This controls the level of audio going to the left and right speakers. In some cases, when the listening area is not absolutely centered between the speakers, it is useful to adjust the center listening point left or right. This menu option gives the ability to adjust the sound left or right up to 18 steps in either direction.

Bass: This adjusts the frequency level from 100Hz and below. The default is flat, and the range is -18dB to +18dB.

Treble: This adjustment works within the same parameters as the bass and adjusts the frequency level from 10kHz and up.

Loudness Compensation: Loudness can be simply turned on or off by pressing the OK button.

Volume Settings: There are several default settings available in this menu. **Volume Reset** is turned on or off by pressing the OK button and controls whether the zone turns on at its previous volume level, or to a preset level, fig. 16. If checked, the volume at zone on reverts to the level set in the next menu item, **Initial Volume**. Choosing to set at the current listening level, or selecting the default -60 dB level, controls this level. **Maximum Volume** is an overall zone volume limit and is set in the same manner as Initial Volume. **Page Volume** controls the level at which a page is amplified in each zone, and **Party Volume** sets the initial volume level when the party or all-on function is initiated.

Display Settings: The brightness of the Control Pad display can be controlled in this menu. **Brightness** sets the overall level of the display. **AutoDim** sets the Control Pad to dim or go completely dark after a set period of time. The range is 15 seconds to 1 hour. **Dim Brightness** works with the AutoDim feature and sets the level of dimness.

Fig. 12

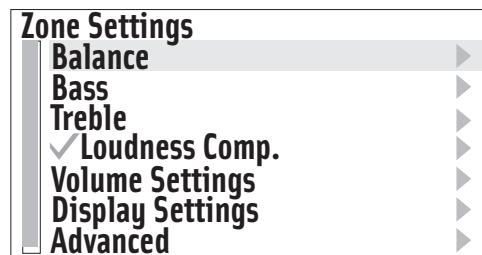

Advanced Zone Settings: These are parameters for each zone. They can be easily established in the Configurator software, or here at each of the zone Control Pads, fig 13.

Source Lockout: Any source selected in this menu will be locked from access within that zone.

Exclusive Src. Ctl.: This sets a default that automatically grabs control of any source chosen within this zone. Other zones will be able to listen, but they will have no specific source control.

Group: Source Group is a great NuVo feature for large, open-floor living spaces. In this menu option, any zone can be set to share source a group of zones to prevent the likelihood of having more than one source playing in the same open space. The advantage to Source Group is that each zone area maintains individual on/off and volume capability.

Default DND: This prevents the global functions of all-on or party and whole-house page from a Control Pad's specific zone.

Default Zone Locked: A locked zone prevents anyone from turning the zone on and accessing music without first entering a security code.

Remote Controls: These settings affect the way the Control Pad receives commands from a handheld wireless remote. The NV-I8GRC1 is the system remote that comes with the Grand Concerto. It allows the same level of control as the Control Pad. At the default setting **All Remotes Enabled**, this remote and any third-party IR remote will be received by the zone's Control Pad. In some instances, you may not want a third-party remote command to be received by the Control Pad. In this case, you would choose **NuVo Remote Only**. If the zone is in an area that is flooded with sunlight or receives interference from plasma displays, the best choice is **All Remotes Disabled**.

Slaved to Zone: A feature of Grand Concerto is the ability to slave zones together. This is most useful for controlling a zone with more than one Control Pad, or the converse, which is controlling more than one zone with one Control Pad. Simply scroll to the zone you wish to slave to and select it from the list.

Zone Number: Each zone must be assigned a number or specific zone address. This is done by scrolling to the desired zone and selecting it. All used zone addresses will be grayed out. If you have defined zones in the Configurator Software, the actual zone names assigned in the Zone tab of the software will appear in the list.

Fig. 13

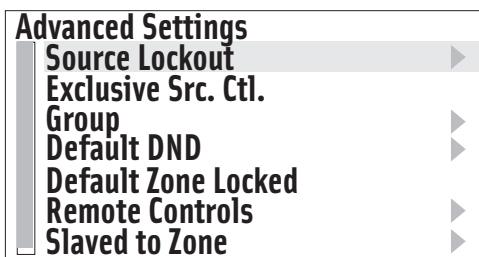

Source Settings: Two choices reside in this menu, fig. 14.

Gain: This lets you increase the audio input levels from the sources coming into the Grand Concerto. This is not necessary for the NuVoNet components, but if you use a satellite or cable set-top box as an audio source for the system, you will find that the audio level is inherently softer and will benefit by the gain setting. The default is 0dB, with a range up to 18.75dB.

NuVoNet Source: If you uncheck this selection, that source will not be polled by NuVoNet and will only be IR controllable.

Fig. 14

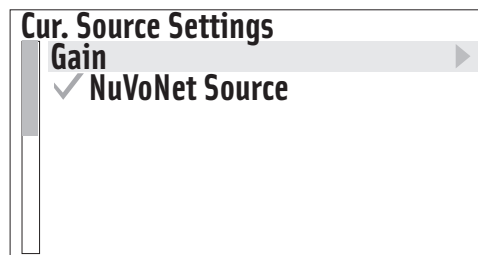

System Settings: This menu option controls system-wide settings, fig 15.

Date/Time: The Grand Concerto has an internal clock that allows each Control Pad to display the current time. Within this menu you can easily set **Year, Month, Day, Hour, and Minute.**

External Mute/Page: The EXT. MUTE input on the back panel of the Grand Concerto has a dual function. In normal mode, it is designed for the Mute Interface, NV-MI1 (see NV-MI1 Mute Interface Adaptor page,). It can also be configured for use with a paging phone system to enable whole-house paging. This requires a phone system that provides an audio output for paging that is plugged into source input 6 on the Grand Concerto (note that this feature eliminates the use of Source 6 as an audio source for the system). To use the Page function, you must select **Paging Mode**. There are two types of voltage triggers associated with the Page function. If the phone system you are using sends a voltage to trigger paging, selecting Paging Mode sets the mute input to react and mute all zones. If it triggers by creating a closure (dropping down to 0 voltage), you need to select **Active High (Open)**.

Sources: This Allows unused source inputs to be turned off so they do not show up when you scroll through the sources at the Control Pads.

XIII. Using the Control Pad for Music Source Control

The Control Pad is a wonderful interface to all the Grand Concerto music sources. The MENU, Forward and Reverse, and Play/Pause buttons ultimately allow complete access to the sources within the system.

Source Main Menu

When the Control Pad is in basic play-back mode, it defaults to a large font suitable for reading from a distance. When the MENU button is pushed, a source-specific menu will appear. An important feature of the Configurator Software is an additional Macro Definition window that allows multiple macros to be defined and automatically added to the source menu with the label **Macros**. This is an important function for sources such as satellite, cable, and multiple-disc changers as a direct access to channels and discs. Once added as a playback menu, these can be incorporated as one of the 12 direct access global favorites.

Fig. 15

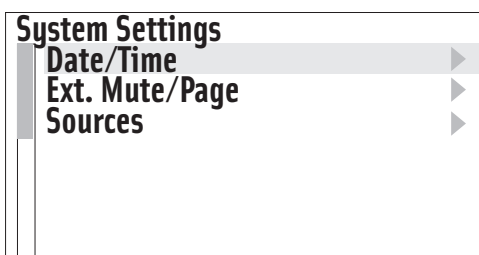

Grand Concerto Accessories

The NV-18DLS IR Learning Station Interface

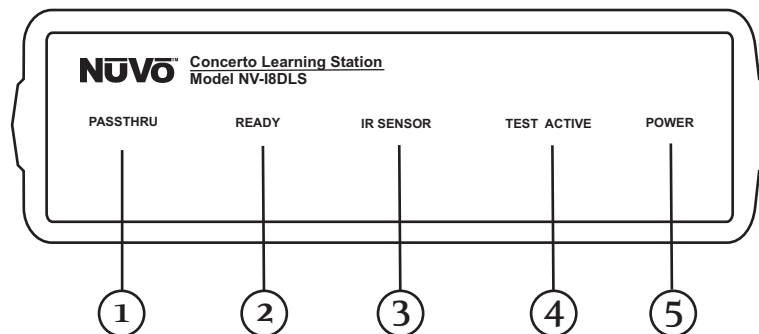

- 1. PASSTHRU:** This LED (light emitting diode) remains lit when the Interface box is actively passing IR information through the system.
- 2. READY:** When you are inputting IR codes into the Configurator using the Interface box, this LED will light when the system is ready to learn a new code.
- 3. IR SENSOR:** This is the IR receiver used when capturing codes for new source equipment.
- 4. TEST ACTIVE:** When you are testing an IR code, this LED lights momentarily when the code is actually firing.
- 5. POWER:** This LED remains lit when the interface box is plugged into an AC electrical outlet.

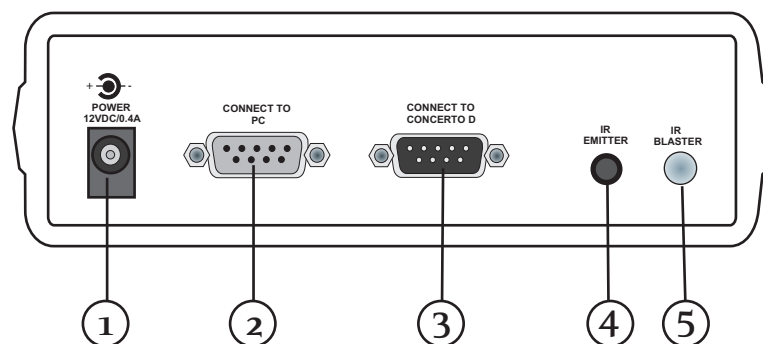

- 1. AC Power:** A standard 12-volt power supply is included in the Learning Station Package. This will supply the necessary AC power for IR learning and testing.
- 2. CONNECT TO PC:** Using one of the supplied RS232 cables, connect from the RS232 port on your computer to this input on the Learning Station Interface.
- 3. CONNECT TO GRAND CONCERTO D:** Using the second RS232 cable, connect the Learning Station Interface to the Grand Concerto amplifier's RS232 port.
- 4. IR EMITTER:** An IR mouse emitter is supplied with the Learning Station package. A feature of the Configurator software is the ability to test each new code that is learned by the interface. The software will send the IR command to the source equipment via the IR emitter, so you can have visual reference that the source equipment responded appropriately to the command.
- 5. IR BLASTER:** Another built-in IR test method is the use of the blaster. The test process is the same in the Configuration program, but the IR Blaster allows you to point the back of the Interface box toward the source equipment IR receiver. This fires the IR command and eliminates the need for the mouse emitter.

Capturing IR codes using the IR Learning Station Interface

The Grand Concerto Configurator software is designed to store IR codes for audio equipment in an IR Library. When the codes are learned for a given piece of equipment, they are held in the library under that equipment's manufacturer name and model number. Once learned, any of the equipment in the library can be imported into a new Configuration.

To learn new equipment codes, the Learning Station Interface box must be connected to your computer at the RS232 port. Connect the male end of the RS232 cable to the back of the Interface box into the "CONNECT TO PC" input. At this point, it is not necessary to have the Interface box connected to the Grand Concerto amplifier.

When setting up a new source, each type of equipment has a pre-selected set of functions. By double-clicking on a function or clicking on the "Record" button in the software, you will open the record window. You will see the "READY" LED light on the interface box. Aim the source's remote control at the "IR SENSOR" on the Interface, and press the desired function button on the remote. The IR learning window in the Configurator software will indicate that the code has been successfully learned. **Note that the remote control should be held 8 to 10 inches from the Interface when learning.**

NV-MI1 Mute Interface Adaptor (fig. 16)

The Mute Interface is used in conjunction with System Mute input on the back of the Essentia amplifier. It acts as relay for a voltage from up to two phone lines and two doorbell transformers. When a voltage is presented to the MI1, it sends a contact closure to the Grand Concerto System, which causes the system to mute momentarily. This is useful in allowing the telephone or doorbell to be heard when audio is playing in any of the zones.

The NuVo NV-MI1 Mute Interface Module is designed to automatically mute any audio playing through the System's speakers when the telephone or doorbell rings.

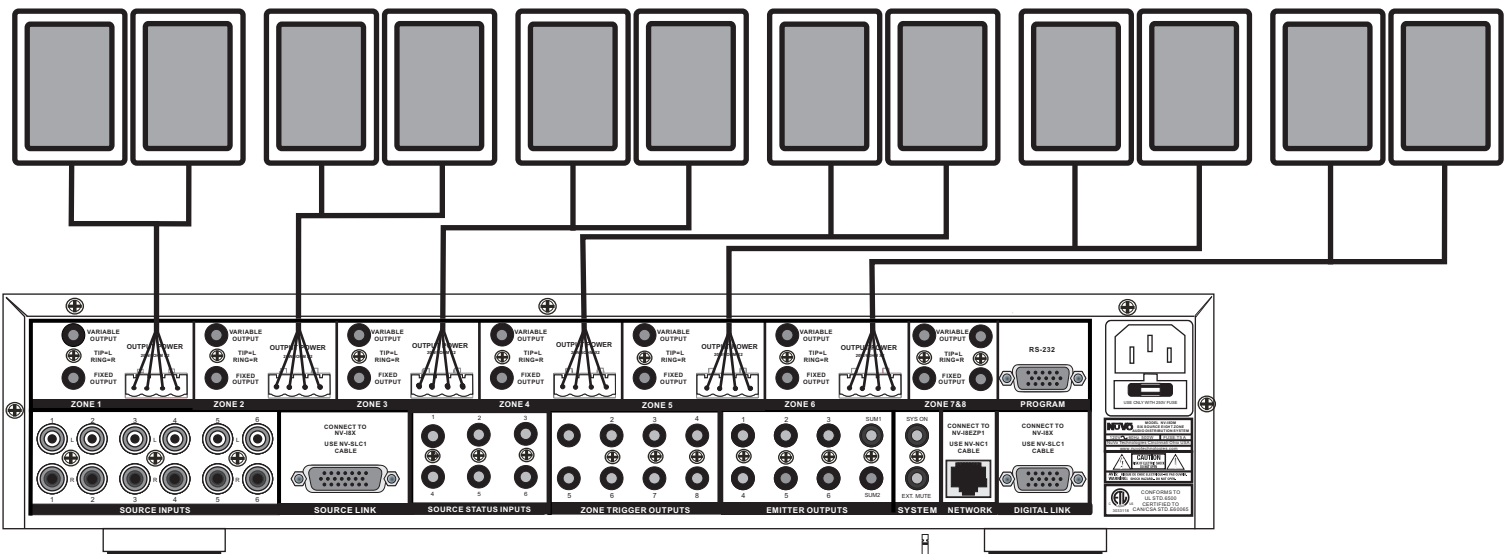

The MI1 connects to the NuVo amplifier using a standard mono patch cable with a mini-plug on each end. Plug one end into the EXT. MUTE input on the back of the amplifier and the other end into the input on the front of the MI1.

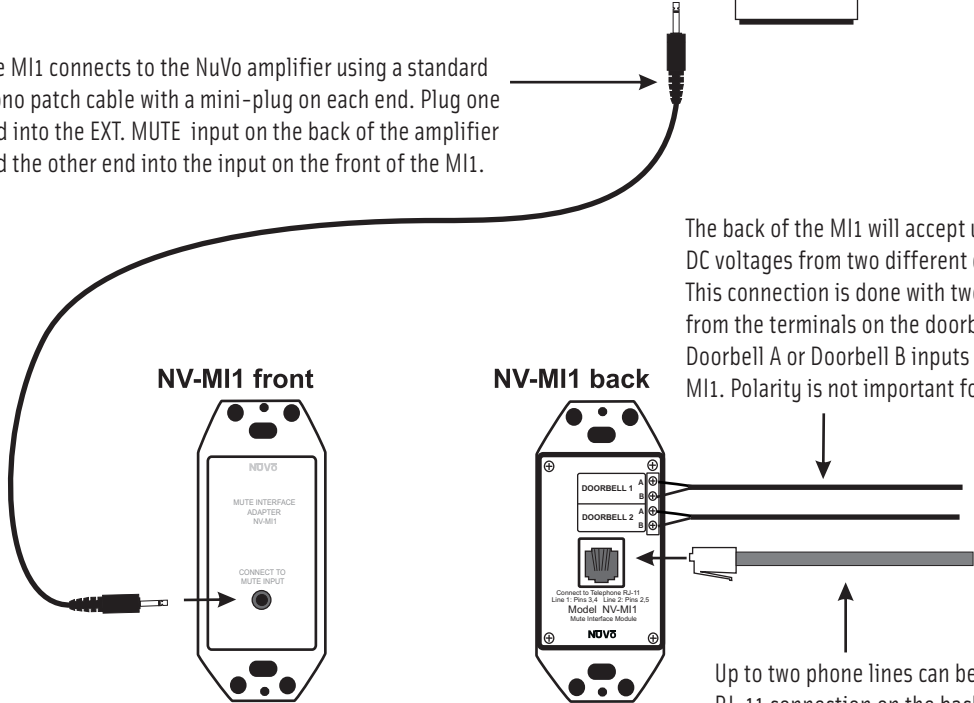

The back of the MI1 will accept up to two AC or DC voltages from two different doorbell chimes. This connection is done with two conductor wire from the terminals on the doorbell chime to the Doorbell A or Doorbell B inputs on the back of the MI1. Polarity is not important for this connection.

Up to two phone lines can be brought into the RJ-11 connection on the back of the MI1. The voltage from the phone ringer will trigger the NuVo System to mute.

NV-LSI24 Local Source Interrupt (fig. 17)

The Local Source Interrupt enables an amplified local audio source to override the Grand Concerto System and play through the local zone in-wall speakers. The most common scenario for this is a television that would benefit from higher-quality speakers.

The back of the Grand Concerto Control Pad has two Cat-5 inputs. One is labeled NuVoNet and is the Cat-5 that runs to the EZ Port at the head end. The other is labeled NV-IGLSA. This is intended to react to the LSI24 accessory. It requires an RJ-45 connection at the Control Pad end and the Brown-and-Brown-Stripe pair as a voltage trigger.

Note that the Local Source Interrupt is a passive non-amplified device. The signal sent to it must be amplified.

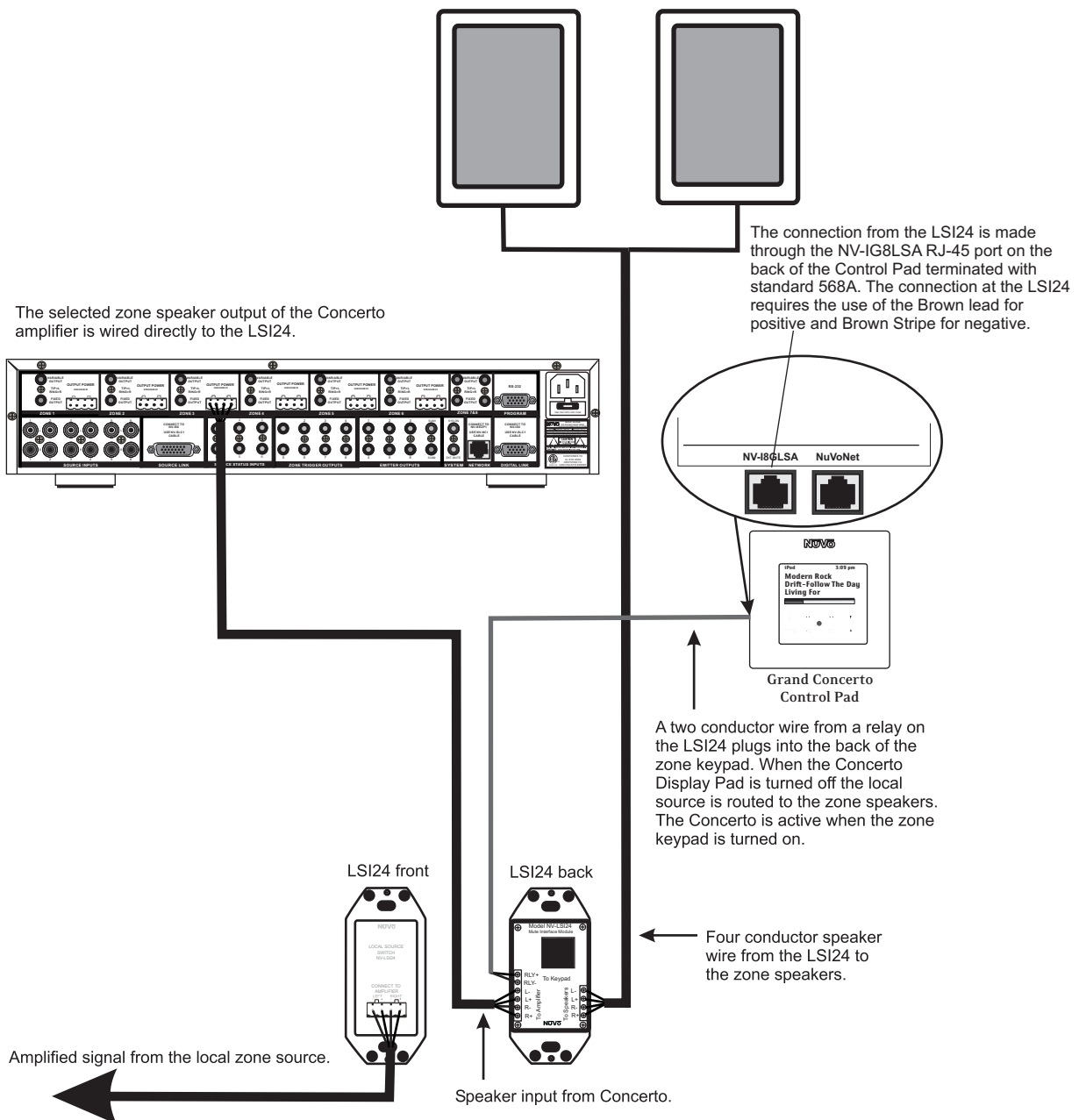

NV-P2100 200-Watt Auxiliary Amplifier (fig. 18)

The P2100 is specifically designed for use with the NuVo Systems' lineouts. It can be used with either the fixed or variable lineouts on the Grand Concerto amplifier. The connection is made using either a 1/8" to 1/8" stereo patch cable or a 1/8" stereo to RCA patch cable.

There are two methods for triggering the P2100 from the Grand Concerto outputs. One is to set the POWER MODE switch on the P2100 to AUDIO (extreme left) position and allow an incoming audio signal from the Grand Concerto System to turn on the P2100. The second method is to place the POWER MODE switch in the AC/DC (extreme right) position. This will turn on the P2100 when the Grand Concerto is on.

An additional feature of Grand Concerto is Zone-Specific Triggers that will trigger the P2100 only when that zone is turned on. Utilizing the voltage trigger requires a mono 1/8" patch cable from either the System ON output on the Grand Concerto to the P2100 Voltage trigger input, or from the specific Zone Trigger on the Grand Concerto to the Voltage Trigger on the P2100, as shown in Fig. 18.

RS232 Interface

The RS232 port allows external two-way communication with the Grand Concerto System. Home automation systems such as Crestron and AMX can be set up to operate Grand Concerto. The RS232 addendum contained in this manual details the necessary code protocol to operate every aspect of the Grand Concerto System.

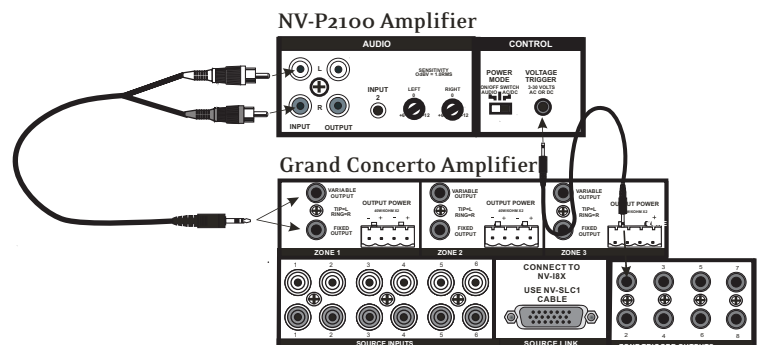

Grand Concerto Specifications

Zones 1-6 Power Amplifier Outputs

Continuous Average Output Power	80W (40W x 2)
Two channels driven 30-20kHz @1% THD	
Rated Distortion (1/2 power)	0.40%
Rated Impedance	6 Ohms
Damping Factor	50+
Frequency Response	20-20kHz ± 2dB

Zones 1-8 Preamplifier Outputs

Variable output	0-600mV
Fixed output	600mV
Impedance	600 Ohms

Source Inputs 1-6

input Impedance	20K
Input Sensitivity for rated power	300mV RMS
Input Overload	3V RMS

Emitter Outputs

Source Outputs	6
Sum Outputs	2
Output Drive Current	100mA
Output Drive Voltage	12V
Compatible with single and dual emitters	

System

System On (output)	12V @ 50mA
External Mute (input)	3-12V DC

NuVo reserves the right to change specifications without notice.

Zone Trigger Outputs

Output Power	12V @ 50mA
Outputs	8 (zones 1-8)

Source Status

Output Power	3-15 VDC
Outputs	6 (Source 1-6)

Power Requirements

Power Supply	120VAC/240VAC 50/60Hz
Power Consumption all channels driven to full-rated power	600VA (480W)
Power Consumption average operating conditions	100VA (80W)
Power Consumption no signal	30VA (25W)
USA Safety Listing (UL 6500)	Pending
Canada Safety Listing (CAN/CSA E60065.00)	Pending
CE Listing/SEMKO (EN60065, EN55013, EN55020, EN6100-3-2, EN6100-3-3/A1)	Pending

Physical Specifications

Unit Size Millimeters	95 x 430 x 340 (LWH)
Unit Size Inches	3 3/4 x 17 x 13 3/8 (LWH)
Shipping Size Millimeters	600 x 475 x 380 (LWH)
Shipping Size Inches	23 5/8 x 18 3/4 x 15 (LWH)
Unit Weight Kilograms	9.4
Unit Weight Pounds	20.6
Shipping Weight Kilograms	15.5
Shipping Weight Pounds	34.0

Grand Concerto Package Contents

NV-I8GMS Grand Concerto System

- NV-I8GM amplifier
- 6 NV-I8GCP Control Pads with white, ivory, almond and black screwless trim plates
- 1 NV-I8GRC1 Remote Control
- 6 NV-VEC IR emitters
- 1 NV-I8EZP EZ Port connection hub
- 1 NV-NC1 3 meter network cable
- 1 NV-I8GRC1 Remote Control
- 1 NV-PC1 IEC Power Cable (USA models only)

NV-I8GXS Grand Concerto Expander System

- NV-I8GX expander amplifier
- 6 NV-I8GCP Control Pads with white, ivory, almond and black screwless trim plates
- 1 NV-I8GRC1 Remote Control
- 1 NV- Audio Link cable
- 1 NV- Digital Link cable
- 1 NV-PC1 IEC Power Cable (USA models only)

NuVo Technologies LLC Hebron, Kentucky USA
www.nuvotechnologies.com

I8G o649

Free Manuals Download Website

<http://myh66.com>

<http://usermanuals.us>

<http://www.somanuals.com>

<http://www.4manuals.cc>

<http://www.manual-lib.com>

<http://www.404manual.com>

<http://www.luxmanual.com>

<http://aubethermostatmanual.com>

Golf course search by state

<http://golfingnear.com>

Email search by domain

<http://emailbydomain.com>

Auto manuals search

<http://auto.somanuals.com>

TV manuals search

<http://tv.somanuals.com>