

User's Guide



Shop online at

omega.com[®]

Ω OMEGA[®]

omega.com

email: Info@omega.com

For latest product manuals:

omegamanual.Info

ISO 9001
CERTIFIED
CORPORATE QUALITY

STAMFORD, CT

ISO 9002
CERTIFIED
CORPORATE QUALITY

MANCHESTER, UK

FMG210/220/230 SERIES Low Flow Magnetic Flow Meter



OMEGAnet® Online Service
omega.com

Internet e-mail
info@omega.com

Servicing North America:

U.S.A.:
ISO 9001 Certified

One Omega Drive, P.O. Box 4047
Stamford, CT 06907-0047
TEL: (203) 359-1660 FAX: (203) 359-7700
e-mail: info@omega.com

Canada:

976 Bergar
Laval (Quebec) H7L 5A1, Canada
TEL: (514) 856-6928 FAX: (514) 856-6886
e-mail: info@omega.ca

For immediate technical or application assistance:

U.S.A. and Canada: Sales Service: 1-800-826-6342 / 1-800-TC-OMEGA®
Customer Service: 1-800-622-2378 / 1-800-622-BEST®
Engineering Service: 1-800-872-9436 / 1-800-USA-WHEN®
TELEX: 996404 EASYLINK: 62968934 CABLE: OMEGA

Mexico:

En Español: (001) 203-359-7803 e-mail: espanol@omega.com
FAX: (001) 203-359-7807 info@omega.com.mx

Servicing Europe:

Benelux:

Postbus 8034, 1180 LA Amstelveen, The Netherlands
TEL: +31 (0)20 3472121 FAX: +31 (0)20 6434643
Toll Free in Benelux: 0800 0993344
e-mail: sales@omegaeng.nl

Czech Republic:

Frystatska 184, 733 01 Karviná, Czech Republic
TEL: +420 (0)59 6311899 FAX: +420 (0)59 6311114
Toll Free: 0800-1-66342 e-mail: info@omegashop.cz

France:

11, rue Jacques Cartier, 78280 Guyancourt, France
TEL: +33 (0)1 61 37 2900 FAX: +33 (0)1 30 57 5427
Toll Free in France: 0800 466 342
e-mail: sales@omega.fr

Germany/Austria:

Daimlerstrasse 26, D-75392 Deckenpfronn, Germany
TEL: +49 (0)7056 9398-0 FAX: +49 (0)7056 9398-29
Toll Free in Germany: 0800 639 7678
e-mail: info@omega.de

United Kingdom:
ISO 9002 Certified

One Omega Drive, River Bend Technology Centre
Northbank, Irlam, Manchester
M44 5BD United Kingdom
TEL: +44 (0)161 777 6611 FAX: +44 (0)161 777 6622
Toll Free in United Kingdom: 0800-488-488
e-mail: sales@omega.co.uk

It is the policy of OMEGA Engineering, Inc. to comply with all worldwide safety and EMC/EMI regulations that apply. OMEGA is constantly pursuing certification of its products to the European New Approach Directives. OMEGA will add the CE mark to every appropriate device upon certification.

The information contained in this document is believed to be correct, but OMEGA accepts no liability for any errors it contains, and reserves the right to alter specifications without notice.

WARNING: These products are not designed for use in, and should not be used for, human applications.

GENERAL INFORMATION

The FMG210/220/230 Series are small electromagnetic low-flow flowmeters with chemically-resistant plastic wetted parts and a choice of Hastelloy or platinum electrodes suitable for use with a variety of chemicals. Capable of measuring pulsating flows from diaphragm-type metering pumps, they are designed primarily for electrically-conductive chemical injection applications. The 1/4", 3/8", and 1/2" sizes monitor maximum flows of 1, 3, and 8 gallons per minute (or 4, 11, and 30 L/min), respectively. Barb or

NPT fittings are available.

The FMG210/220/230 Series are 12-24 Vdc powered and come with standard pulse and analog outputs. All electronics are self-contained in a single compact chemically-resistant housing, well suited for OEM applications.

These meters are also appropriate for remote monitoring of chemical volume or rate using a computer or a PLC.

FEATURES

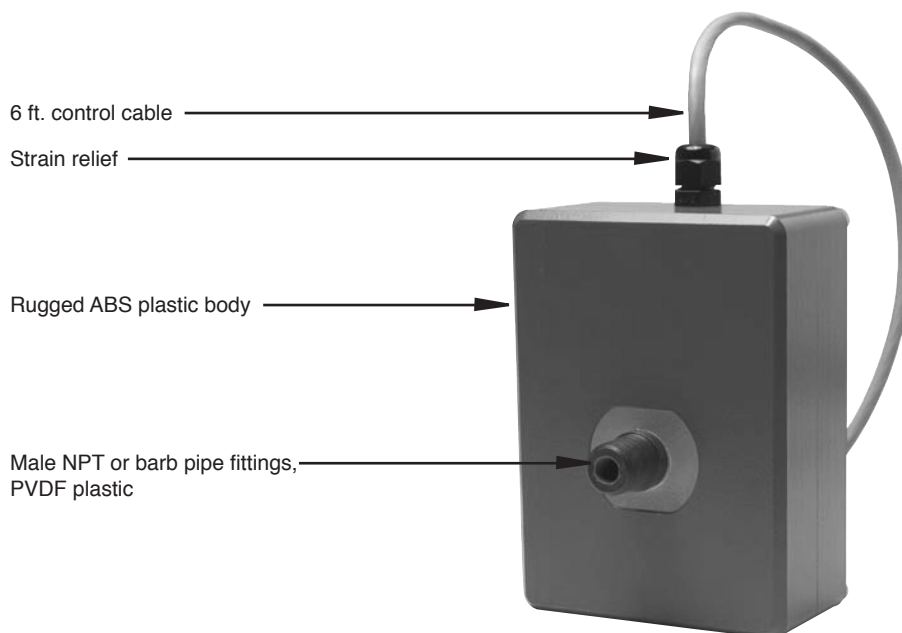

SPECIFICATIONS

Materials Body	ABS plastic
Electrodes	Platinum or Hastelloy
O-Ring	Viton™ (EPDM optional)
Fittings	PVDF plastic
Power	12-24 Vdc, 180 mA
Accuracy	+/-1% of reading, plus .005 gpm (0.02 lpm)
Max Fluid Temperature	185° F (85° C)
Maximum Pressure	150 psi (@ 75° F)
Minimum Conductivity	20 microSiemens
Outputs	<ul style="list-style-type: none"> • Frequency opto isolated 1000 pulse/liter (3785 p/g) • 4-20 mA opto isolated passive

FLOW RANGE

SIZE	LOW FLOW CUTOFF			MINIMUM FLOW for spec accuracy			MAXIMUM FLOW		
	L/MIN	GAL/MIN	GAL/HR	L/MIN	GAL/MIN	GAL/HR	L/MIN	GAL/MIN	GAL/HR
-025	.04	.01	.60	.26	.07	4.2	3.8	1	60
-038	.11	.03	1.80	.76	0.2	12	11	3	180
-050	.26	.07	4.20	1.9	0.5	30	30	8	480

INSTALLATION, CONNECTIONS, and OPERATION

INSTALLATION

Mounting. The FMG210/220/230 can be supported by its piping connections if the piping is rigid and there is no vibration. Alternatively, the grounding studs can be used for mounting by inserting them through pre-drilled holes. Note the centerline distance in the dimensional drawing on following page.



CAUTION: Although this meter has an empty pipe detection function, under certain conditions of empty or partially-full pipe the meter may read a flow when there is none. If this is a hazardous condition, mount the meter in such a way as to ensure the meter will always be full of liquid.

Piping. Metallic pipe or tube, or plastic tubing, can be used with the meter. The meter comes with male NPT or barb fittings (see chart, next page, for sizes).

For plastic tubing, use female NPT tubing adaptors. In installations exposed to vibration, it is not recommended to use the piping as the sole support for the meter, particularly on the smaller sizes.

A minimum of 1" of straight pipe run is recommended on the inlet side of the meter. Straight run is not necessary on the outlet.

CONNECTIONS

Power and signal connections are provided by the single 4- or 6-conductor color-coded cable. See the Wiring Connections chart on next page. In addition, it is necessary for proper operation to ground the unit to a good quality earth ground. Use the 12 ft. grounding wire supplied with the unit, or if necessary, a longer wire attached to one or both of the grounding studs. If metal piping is used, ground connections from the grounding studs on the bottom of the unit to both inlet and outlet pipes provide the best results in metering accuracy. See Grounding diagrams.

OPERATION

The newly-installed meter takes from a few seconds to a minute for the signal to stabilize at startup, especially if it has been dry. In normal operation, keep the meter filled with fluid to prevent this delay. An empty pipe detection feature will normally detect absence of liquid in the pipe and register zero flow when the meter is mounted properly.

The **4-20 mA signal** outputs 4 mA at zero flow and 20 mA at maximum rated flow. The **standard pulse signal** is a 50% duty cycle pulse set at 1000 pulses/liter (3785 pulses/gallon).

INSTALLATION, CONNECTIONS and GROUNDING

DIMENSIONS

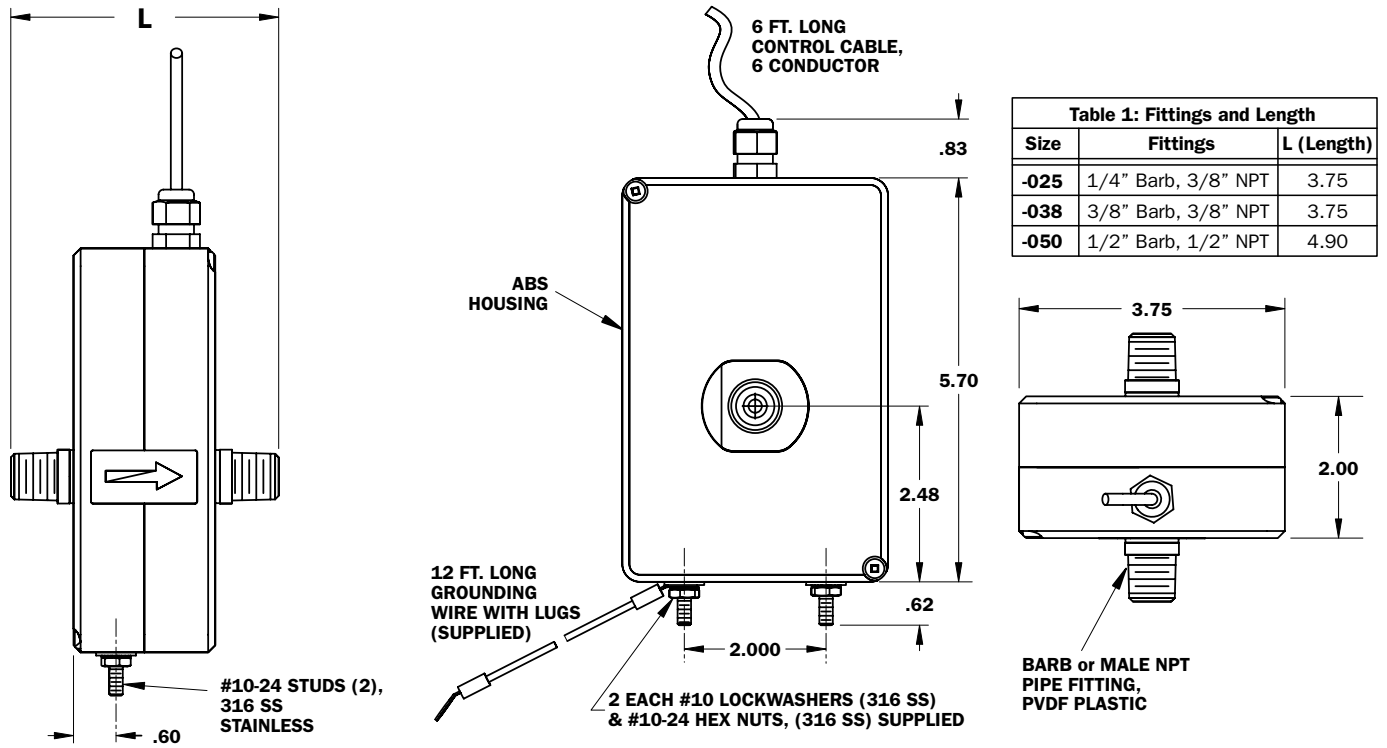

IDEAL GROUNDING WITH METALLIC PIPING

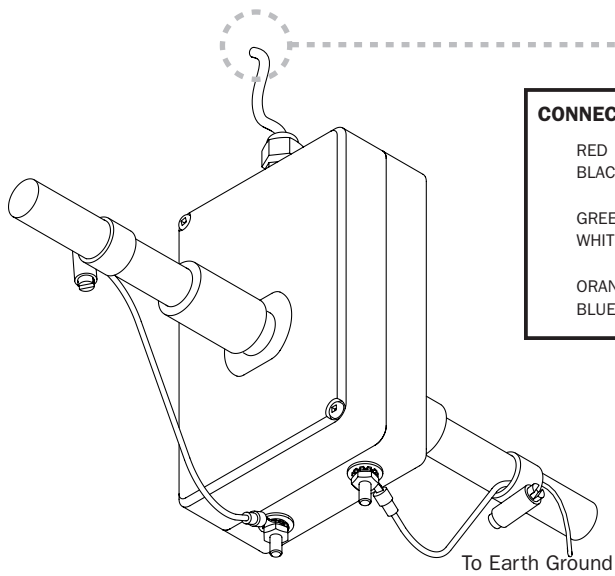

STANDARD GROUNDING

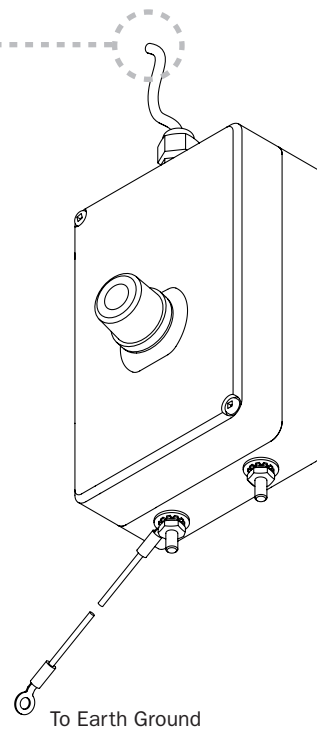

RED	+ 12 to 24 Vdc Power
BLACK	- Power
GREEN	+ Pulse Output Isolated
WHITE	- Pulse Output Isolated
ORANGE	+ 4-20 mA Isolated
BLUE	- 4-20 mA Isolated

TROUBLESHOOTING

Problem	Probable Causes	Try...
Analog output at 0 mA	No loop power	4-20 mA loop needs an external power supply - if missing, add it
Analog output is 4 mA with flow	Unit not grounded Flow reversed	Connect to earth ground Note flow direction arrow, reverse direction to match
No pulse output	Reversed output connections Not grounded Reversed flow	Change output connection Connect to earth ground Change flow direction
Flow rate incorrect	Missing or incorrect ground wire Fluid conductivity <20 microSiemens/cm Empty pipe	Check for proper grounding Select another flow meter Install meter in vertical position



WARRANTY/DISCLAIMER

OMEGA ENGINEERING, INC. warrants this unit to be free of defects in materials and workmanship for a period of **13 months** from date of purchase. OMEGA's WARRANTY adds an additional one (1) month grace period to the normal **one (1) year product warranty** to cover handling and shipping time. This ensures that OMEGA's customers receive maximum coverage on each product.

If the unit malfunctions, it must be returned to the factory for evaluation. OMEGA's Customer Service Department will issue an Authorized Return (AR) number immediately upon phone or written request. Upon examination by OMEGA, if the unit is found to be defective, it will be repaired or replaced at no charge. OMEGA's WARRANTY does not apply to defects resulting from any action of the purchaser, including but not limited to mishandling, improper interfacing, operation outside of design limits, improper repair, or unauthorized modification. This WARRANTY is VOID if the unit shows evidence of having been tampered with or shows evidence of having been damaged as a result of excessive corrosion; or current, heat, moisture or vibration; improper specification; misapplication; misuse or other operating conditions outside of OMEGA's control. Components in which wear is not warranted, include but are not limited to contact points, fuses, and triacs.

OMEGA is pleased to offer suggestions on the use of its various products. However, OMEGA neither assumes responsibility for any omissions or errors nor assumes liability for any damages that result from the use of its products in accordance with information provided by OMEGA, either verbal or written. OMEGA warrants only that the parts manufactured by the company will be as specified and free of defects. OMEGA MAKES NO OTHER WARRANTIES OR REPRESENTATIONS OF ANY KIND WHATSOEVER, EXPRESSED OR IMPLIED, EXCEPT THAT OF TITLE, AND ALL IMPLIED WARRANTIES INCLUDING ANY WARRANTY OF MERCHANTABILITY AND FITNESS FOR A PARTICULAR PURPOSE ARE HEREBY DISCLAIMED. LIMITATION OF LIABILITY: The remedies of purchaser set forth herein are exclusive, and the total liability of OMEGA with respect to this order, whether based on contract, warranty, negligence, indemnification, strict liability or otherwise, shall not exceed the purchase price of the component upon which liability is based. In no event shall OMEGA be liable for consequential, incidental or special damages.

CONDITIONS: Equipment sold by OMEGA is not intended to be used, nor shall it be used: (1) as a "Basic Component" under 10 CFR 21 (NRC), used in or with any nuclear installation or activity; or (2) in medical applications or used on humans. Should any Product(s) be used in or with any nuclear installation or activity, medical application, used on humans, or misused in any way, OMEGA assumes no responsibility as set forth in our basic WARRANTY/DISCLAIMER language, and, additionally, purchaser will indemnify OMEGA and hold OMEGA harmless from any liability or damage whatsoever arising out of the use of the Product(s) in such a manner.

RETURN REQUESTS/INQUIRIES

Direct all warranty and repair requests/inquiries to the OMEGA Customer Service Department. BEFORE RETURNING ANY PRODUCT(S) TO OMEGA, PURCHASER MUST OBTAIN AN AUTHORIZED RETURN (AR) NUMBER FROM OMEGA'S CUSTOMER SERVICE DEPARTMENT (IN ORDER TO AVOID PROCESSING DELAYS). The assigned AR number should then be marked on the outside of the return package and on any correspondence.

The purchaser is responsible for shipping charges, freight, insurance and proper packaging to prevent breakage in transit.

FOR **WARRANTY** RETURNS, please have the following information available BEFORE contacting OMEGA:

1. Purchase Order number under which the product was PURCHASED,
2. Model and serial number of the product under warranty, and
3. Repair instructions and/or specific problems relative to the product.

FOR **NON-WARRANTY** REPAIRS, consult OMEGA for current repair charges. Have the following information available BEFORE contacting OMEGA:

1. Purchase Order number to cover the COST of the repair,
2. Model and serial number of the product, and
3. Repair instructions and/or specific problems relative to the product.

OMEGA's policy is to make running changes, not model changes, whenever an improvement is possible. This affords our customers the latest in technology and engineering.

OMEGA is a registered trademark of OMEGA ENGINEERING, INC.

© Copyright 2005 OMEGA ENGINEERING, INC. All rights reserved. This document may not be copied, photocopied, reproduced, translated, or reduced to any electronic medium or machine-readable form, in whole or in part, without the prior written consent of OMEGA ENGINEERING, INC.

Where Do I Find Everything I Need for Process Measurement and Control? **OMEGA...Of Course!** *Shop online at omega.com*

TEMPERATURE

- ☑ Thermocouple, RTD & Thermistor Probes, Connectors, Panels & Assemblies
- ☑ Wire: Thermocouple, RTD & Thermistor
- ☑ Calibrators & Ice Point References
- ☑ Recorders, Controllers & Process Monitors
- ☑ Infrared Pyrometers

PRESSURE, STRAIN AND FORCE

- ☑ Transducers & Strain Gages
- ☑ Load Cells & Pressure Gages
- ☑ Displacement Transducers
- ☑ Instrumentation & Accessories

FLOW/LEVEL

- ☑ Rotameters, Gas Mass Flowmeters & Flow Computers
- ☑ Air Velocity Indicators
- ☑ Turbine/Paddlewheel Systems
- ☑ Totalizers & Batch Controllers

pH/CONDUCTIVITY

- ☑ pH Electrodes, Testers & Accessories
- ☑ Benchtop/Laboratory Meters
- ☑ Controllers, Calibrators, Simulators & Pumps
- ☑ Industrial pH & Conductivity Equipment

DATA ACQUISITION

- ☑ Data Acquisition & Engineering Software
- ☑ Communications-Based Acquisition Systems
- ☑ Plug-in Cards for Apple, IBM & Compatibles
- ☑ Datalogging Systems
- ☑ Recorders, Printers & Plotters

HEATERS

- ☑ Heating Cable
- ☑ Cartridge & Strip Heaters
- ☑ Immersion & Band Heaters
- ☑ Flexible Heaters
- ☑ Laboratory Heaters

ENVIRONMENTAL MONITORING AND CONTROL

- ☑ Metering & Control Instrumentation
- ☑ Refractometers
- ☑ Pumps & Tubing
- ☑ Air, Soil & Water Monitors
- ☑ Industrial Water & Wastewater Treatment
- ☑ pH, Conductivity & Dissolved Oxygen Instruments

Free Manuals Download Website

<http://myh66.com>

<http://usermanuals.us>

<http://www.somanuals.com>

<http://www.4manuals.cc>

<http://www.manual-lib.com>

<http://www.404manual.com>

<http://www.luxmanual.com>

<http://aubethermostatmanual.com>

Golf course search by state

<http://golfingnear.com>

Email search by domain

<http://emailbydomain.com>

Auto manuals search

<http://auto.somanuals.com>

TV manuals search

<http://tv.somanuals.com>