

## Where Do I Find Everything I Need for Process Measurement and Control? OMEGA...Of Course!

### TEMPERATURE

- ☑ Thermocouple, RTD & Thermistor Probes, Connectors, Panels & Assemblies
- ☑ Wire: Thermocouple, RTD & Thermistor
- ☑ Calibrators & Ice Point References
- ☑ Recorders, Controllers & Process Monitors
- ☑ Infrared Pyrometers

### PRESSURE, STRAIN AND FORCE

- ☑ Transducers & Strain Gauges
- ☑ Load Cells & Pressure Gauges
- ☑ Displacement Transducers
- ☑ Instrumentation & Accessories

### FLOW/LEVEL

- ☑ Rotameters, Gas Mass Flowmeters & Flow Computers
- ☑ Air Velocity Indicators
- ☑ Turbine/Paddlewheel Systems
- ☑ Totalizers & Batch Controllers

### pH/CONDUCTIVITY

- ☑ pH Electrodes, Testers & Accessories
- ☑ Benchtop/Laboratory Meters
- ☑ Controllers, Calibrators, Simulators & Pumps
- ☑ Industrial pH & Conductivity Equipment

### DATA ACQUISITION

- ☑ Data Acquisition & Engineering Software
- ☑ Communications-Based Acquisition Systems
- ☑ Plug-in Cards for Apple, IBM & Compatibles
- ☑ Datalogging Systems
- ☑ Recorders, Printers & Plotters

### HEATERS

- ☑ Heating Cable
- ☑ Cartridge & Strip Heaters
- ☑ Immersion & Band Heaters
- ☑ Flexible Heaters
- ☑ Laboratory Heaters

### ENVIRONMENTAL MONITORING AND CONTROL

- ☑ Metering & Control Instrumentation
- ☑ Refractometers
- ☑ Pumps & Tubing
- ☑ Air, Soil & Water Monitors
- ☑ Industrial Water & Wastewater Treatment
- ☑ pH, Conductivity & Dissolved Oxygen Instruments

M-3444 / 0799



# User's Guide



<http://www.omega.com>  
e-mail: [info@omega.com](mailto:info@omega.com)

## LVU-90 Series Ultrasonic Level Transmitter

**WARNING:** These products are not designed for use in, and should not be used for, patient connected applications. Omega, and reserves the right to alter specifications without notice. The information contained in this manual is believed to be correct but OMEGA Engineering, Inc. accepts no liability for any errors it contains, and reserves the right to alter specifications without notice. This document may not be copied, reproduced, translated, or reduced to any electronic medium or machine-readable form, in whole or in part, without prior written consent of OMEGA ENGINEERING, INC.

OMEGA is a registered trademark of OMEGA ENGINEERING, INC. All rights reserved. This document may not be copied, reproduced, translated, or reduced to any electronic medium or machine-readable form, in whole or in part, without prior written consent of OMEGA ENGINEERING, INC. This manual is believed to be correct but OMEGA Engineering, Inc. accepts no liability for any errors it contains, and reserves the right to alter specifications without notice. The information contained in this manual is believed to be correct but OMEGA Engineering, Inc. accepts no liability for any errors it contains, and reserves the right to alter specifications without notice. This document may not be copied, reproduced, translated, or reduced to any electronic medium or machine-readable form, in whole or in part, without prior written consent of OMEGA ENGINEERING, INC.

OMEGA is a registered trademark of OMEGA ENGINEERING, INC. All rights reserved. This document may not be copied, reproduced, translated, or reduced to any electronic medium or machine-readable form, in whole or in part, without prior written consent of OMEGA ENGINEERING, INC. This manual is believed to be correct but OMEGA Engineering, Inc. accepts no liability for any errors it contains, and reserves the right to alter specifications without notice. The information contained in this manual is believed to be correct but OMEGA Engineering, Inc. accepts no liability for any errors it contains, and reserves the right to alter specifications without notice. This document may not be copied, reproduced, translated, or reduced to any electronic medium or machine-readable form, in whole or in part, without prior written consent of OMEGA ENGINEERING, INC.

OMEGA is a registered trademark of OMEGA ENGINEERING, INC. All rights reserved. This document may not be copied, reproduced, translated, or reduced to any electronic medium or machine-readable form, in whole or in part, without prior written consent of OMEGA ENGINEERING, INC. This manual is believed to be correct but OMEGA Engineering, Inc. accepts no liability for any errors it contains, and reserves the right to alter specifications without notice. The information contained in this manual is believed to be correct but OMEGA Engineering, Inc. accepts no liability for any errors it contains, and reserves the right to alter specifications without notice. This document may not be copied, reproduced, translated, or reduced to any electronic medium or machine-readable form, in whole or in part, without prior written consent of OMEGA ENGINEERING, INC.

OMEGA is a registered trademark of OMEGA ENGINEERING, INC. All rights reserved. This document may not be copied, reproduced, translated, or reduced to any electronic medium or machine-readable form, in whole or in part, without prior written consent of OMEGA ENGINEERING, INC. This manual is believed to be correct but OMEGA Engineering, Inc. accepts no liability for any errors it contains, and reserves the right to alter specifications without notice. The information contained in this manual is believed to be correct but OMEGA Engineering, Inc. accepts no liability for any errors it contains, and reserves the right to alter specifications without notice. This document may not be copied, reproduced, translated, or reduced to any electronic medium or machine-readable form, in whole or in part, without prior written consent of OMEGA ENGINEERING, INC.

OMEGA is a registered trademark of OMEGA ENGINEERING, INC. All rights reserved. This document may not be copied, reproduced, translated, or reduced to any electronic medium or machine-readable form, in whole or in part, without prior written consent of OMEGA ENGINEERING, INC. This manual is believed to be correct but OMEGA Engineering, Inc. accepts no liability for any errors it contains, and reserves the right to alter specifications without notice. The information contained in this manual is believed to be correct but OMEGA Engineering, Inc. accepts no liability for any errors it contains, and reserves the right to alter specifications without notice. This document may not be copied, reproduced, translated, or reduced to any electronic medium or machine-readable form, in whole or in part, without prior written consent of OMEGA ENGINEERING, INC.

OMEGA is a registered trademark of OMEGA ENGINEERING, INC. All rights reserved. This document may not be copied, reproduced, translated, or reduced to any electronic medium or machine-readable form, in whole or in part, without prior written consent of OMEGA ENGINEERING, INC. This manual is believed to be correct but OMEGA Engineering, Inc. accepts no liability for any errors it contains, and reserves the right to alter specifications without notice. The information contained in this manual is believed to be correct but OMEGA Engineering, Inc. accepts no liability for any errors it contains, and reserves the right to alter specifications without notice. This document may not be copied, reproduced, translated, or reduced to any electronic medium or machine-readable form, in whole or in part, without prior written consent of OMEGA ENGINEERING, INC.

OMEGA is a registered trademark of OMEGA ENGINEERING, INC. All rights reserved. This document may not be copied, reproduced, translated, or reduced to any electronic medium or machine-readable form, in whole or in part, without prior written consent of OMEGA ENGINEERING, INC. This manual is believed to be correct but OMEGA Engineering, Inc. accepts no liability for any errors it contains, and reserves the right to alter specifications without notice. The information contained in this manual is believed to be correct but OMEGA Engineering, Inc. accepts no liability for any errors it contains, and reserves the right to alter specifications without notice. This document may not be copied, reproduced, translated, or reduced to any electronic medium or machine-readable form, in whole or in part, without prior written consent of OMEGA ENGINEERING, INC.

OMEGA is a registered trademark of OMEGA ENGINEERING, INC. All rights reserved. This document may not be copied, reproduced, translated, or reduced to any electronic medium or machine-readable form, in whole or in part, without prior written consent of OMEGA ENGINEERING, INC. This manual is believed to be correct but OMEGA Engineering, Inc. accepts no liability for any errors it contains, and reserves the right to alter specifications without notice. The information contained in this manual is believed to be correct but OMEGA Engineering, Inc. accepts no liability for any errors it contains, and reserves the right to alter specifications without notice. This document may not be copied, reproduced, translated, or reduced to any electronic medium or machine-readable form, in whole or in part, without prior written consent of OMEGA ENGINEERING, INC.

OMEGA is a registered trademark of OMEGA ENGINEERING, INC. All rights reserved. This document may not be copied, reproduced, translated, or reduced to any electronic medium or machine-readable form, in whole or in part, without prior written consent of OMEGA ENGINEERING, INC. This manual is believed to be correct but OMEGA Engineering, Inc. accepts no liability for any errors it contains, and reserves the right to alter specifications without notice. The information contained in this manual is believed to be correct but OMEGA Engineering, Inc. accepts no liability for any errors it contains, and reserves the right to alter specifications without notice. This document may not be copied, reproduced, translated, or reduced to any electronic medium or machine-readable form, in whole or in part, without prior written consent of OMEGA ENGINEERING, INC.

OMEGA is a registered trademark of OMEGA ENGINEERING, INC. All rights reserved. This document may not be copied, reproduced, translated, or reduced to any electronic medium or machine-readable form, in whole or in part, without prior written consent of OMEGA ENGINEERING, INC. This manual is believed to be correct but OMEGA Engineering, Inc. accepts no liability for any errors it contains, and reserves the right to alter specifications without notice. The information contained in this manual is believed to be correct but OMEGA Engineering, Inc. accepts no liability for any errors it contains, and reserves the right to alter specifications without notice. This document may not be copied, reproduced, translated, or reduced to any electronic medium or machine-readable form, in whole or in part, without prior written consent of OMEGA ENGINEERING, INC.

# SPECIFICATIONS

## Step One

- Range: 3.6" to 6' (9 cm to 1.8 m)
- Accuracy: ± .25% of span in air
- Resolution: 0.125" (3 mm)
- Frequency: 83 kHz (nominal)
- Pulse rate: 2 pulses per second
- Beam width: 8° conical
- Dead band: 3.6" (9 cm)
- Supply voltage: 12-36 VDC
- Max loop resistance: 600 Ohms @ 36 VDC
- Signal output: 4-20 mA, 12-36 VDC
- Fail-safe diagnostics: Reverts to 22 mA  
LED flashing
- Temperature rating: F: -40° to 140°  
C: -40° to 60°
- Temp. compensation: Automatic over entire range
- Pressure rating: 30 psi (2 bar) @ 25 °C., derated @ 1.667 psi  
(0.113 bar) per °C. above 25 °C.
- Enclosure rating: NEMA 4X / IP65
- Enclosure material: Polypropylene, U.L. 94VO
- Transducer materials: PVDF
- Mounting threads: 3/4" NPT for LVU-91  
3/4" G for LVU-92
- Mounting gasket: Viton (3/4" G) LVU-92 only
- Conduit connection: 1/2" NPT
- CE compliance: EN 50082-2 immunity  
EN 55011 emission  
(pending)

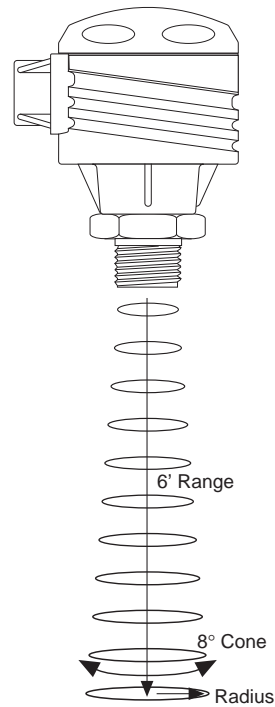
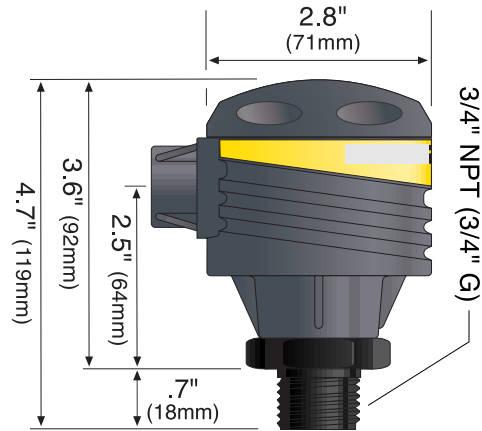

Range Feet	Radius Inches	Radius cm
1	1.2	3.1
2	2.1	5.2
3	2.9	7.3
4	3.7	9.5
5	4.9	11.6
6	5.4	13.7

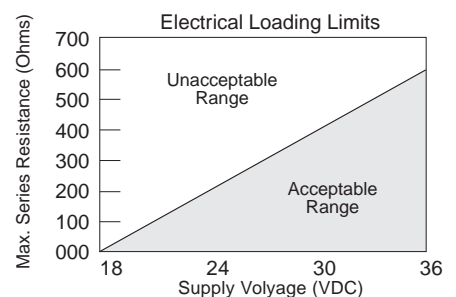
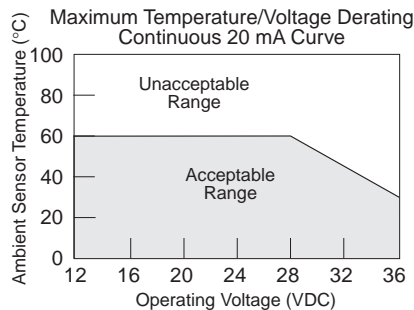
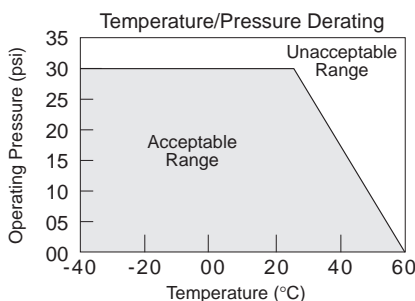
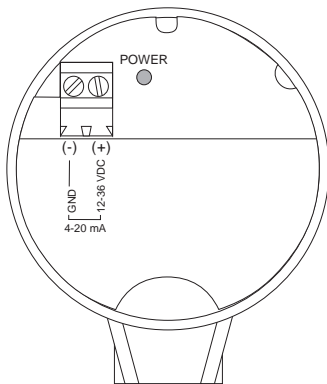

## SAFETY PRECAUTIONS

### Step Two

#### **About this Manual:**

PLEASE READ THE ENTIRE MANUAL PRIOR TO INSTALLING OR USING THIS PRODUCT. This manual includes information on the LVU-90 series continuous non-contact level transmitter from OMEGA. Please refer to the part number located on the sensor label to verify the exact model which you have purchased.

#### **User's Responsibility for Safety:**

OMEGA manufactures a wide range of liquid level sensors and technologies. While each of these sensors is designed to operate in a wide variety of applications, it is the user's responsibility to select a sensor model that is appropriate for the application, install it properly, perform tests of the installed system, and maintain all components. The failure to do so could result in property damage or serious injury.

#### **Proper Installation and Handling:**

Because this is an electrically operated device, only properly-trained staff should install and/or repair this product. Use a proper sealant with all installations. Note: *Always install the 3/4" Viton gasket with the LVU-92. The G threaded version will not seal unless the gasket is installed properly.* Never overtighten the transmitter within the fitting. Always check for leaks prior to system start-up.

#### **Wiring and Electrical:**

A supply voltage of 12-36 VDC is used to power the transmitter. The sensor systems should never exceed a maximum of 36 volts DC. Electrical wiring of the sensor should be performed in accordance with all applicable national, state, and local codes.

#### **Material Compatibility:**

The enclosure is made of Polypropylene (PP). The transducer is made of Polyvinylidene Fluoride (PVDF). Make sure that the model which you have selected is chemically compatible with the application liquids it will contact.

#### **Enclosure:**

While the transmitter housing is liquid-resistant when installed properly, it is not designed to be immersed. It should be mounted in such a way that the enclosure and diaphragm do not come into contact with fluid.

#### **Make a Fail-Safe System:**

Design a fail-safe system that accommodates the possibility of transmitter or power failure. In critical applications, OMEGA recommends the use of redundant backup systems and alarms in addition to the primary system.

#### **Flammable, Explosive and Hazardous Applications:**

The LVU-90 series transmitter systems should not be used within flammable or explosive applications.

#### **Warning**

Always install the 3/4" Viton gasket with the LVU-92. The LVU-92 G threaded version will not seal unless the gasket is installed properly.

## WIRING

### Step Three

#### **Wiring to Terminal:**

The LVU-90 arrives from the factory pre-calibrated and pre-assembled. Use the following instructions below for wiring to the LVU-90.

1. First, remove the cap of the transmitter:
2. Look for the terminal block with two terminals.

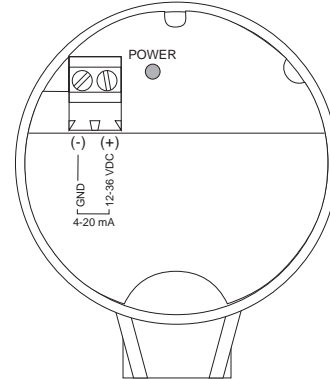

3. Remove the terminal block to wire the LVU-90. The terminal to the right is positive and the terminal to the left is negative.
4. When finished attaching the wires, assemble the LVU-90 using steps 1 - 3 in reverse.

# WIRING

## Step Four

Follow the instructions in Step 3 for wiring to the LVU-90.

- 1. Wiring to an OMEGA Continuous Controller (LVCN-51):**  
Connect the (+) terminal to the positive 24 VDC, 25 mA terminal on the controller. Connect the (-) terminal to the GND terminal on the continuous controller (See illustration below). Check LVCN-51 instruction manual for setting the LVCN-51 for loop powered operation.

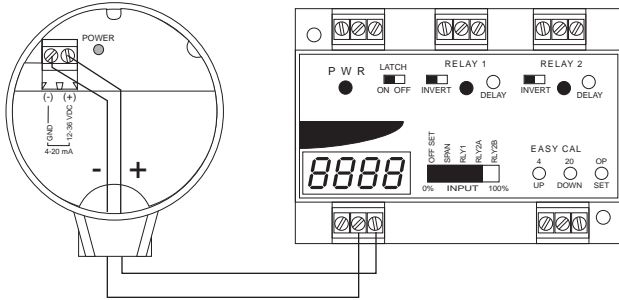

- 2. Wiring to a Two-Wire Loop Powered Indicator:**

The LVCN-90 requires 12-36 VDC power and an indicator which receives a 4-20 mA current input. Connect the (+) terminal of the LVCN-90 transmitter to the positive VDC terminal on the power supply. Connect the (-) terminal on the LVCN-90 to the (+) terminal on the loop indicator. Connect the (-) of the loop indicator to the (-) of the power supply (See illustration below).

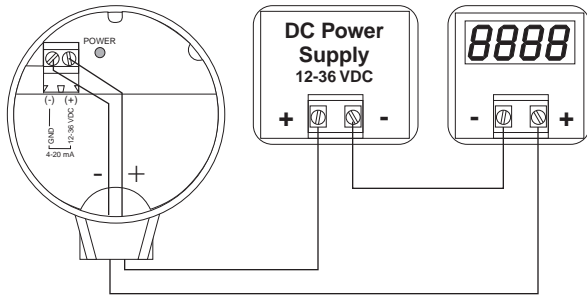

- 3. Wiring to a Typical PLC:**

The LVCN-90 requires a PLC which provides a 12-36 VDC excitation and receives a 4-20 mA current input. Connect the (+) terminal of the LVCN-90 transmitter to the positive VDC power terminal. Connect the (-) terminal on the LVCN-90 to the (+) channel on the PLC. Connect the (-) of the PLC to the (-) of the power terminal (See illustration below).

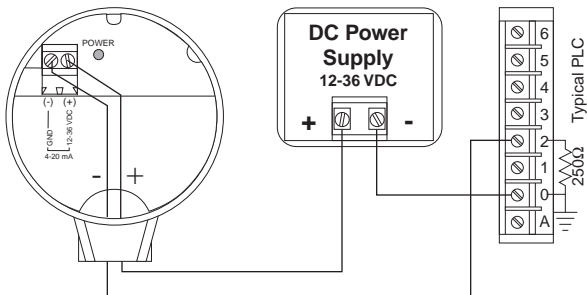

\* 250 Ω resistor typically internal to PLC

# INSTALLATION

## Step Five

The LVCN-90 transmitter may be installed through the top wall of a tank. Installation requires a 3/4" NPT fitting or blind flange.

1. Install the appropriate 3/4" fitting in the top wall of the tank. Prior to installation, make sure that the fitting has been installed properly and checked for leaks. Use a proper sealant at the time of installation to ensure a liquid-tight seal. Secondly, make sure that the fitting's threads are not damaged or worn.
2. Insert the Transmitter into the fitting and tighten to hand tight.
3. Always check for leaks prior to system start-up. To ensure proper installation, a complete leak test and simulation of actual process conditions should be preformed.

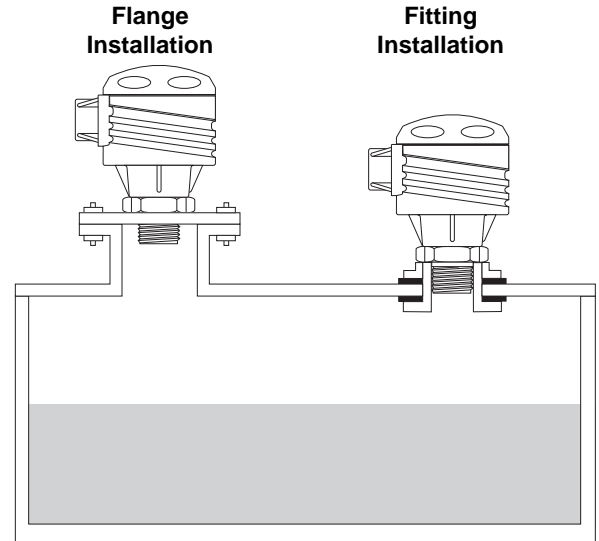

### Warning

Do not install the LVCN-90 in pressurized applications above 30 psi.

Always install the 3/4" Viton gasket with the LVCN-92. The LVCN-92 G threaded version will not seal unless the gasket is installed properly and checked for leaks.

Use a proper sealant at the time of installation to ensure a liquid-tight seal. Secondly, make sure that the fitting's threads are not damaged or worn.

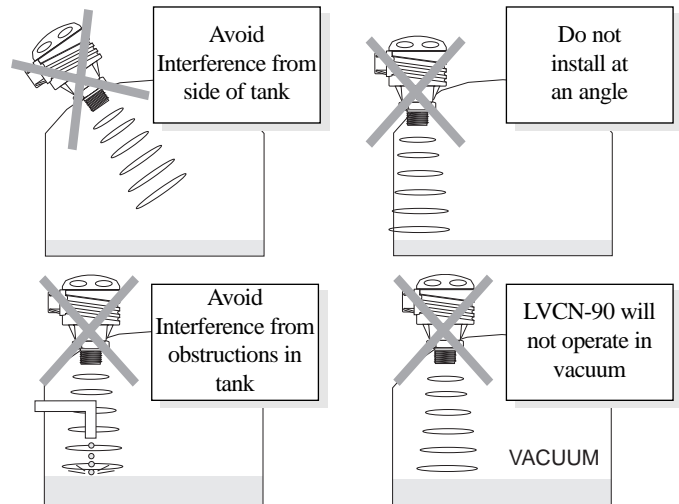

# CALIBRATION

## Step Six

The LVCN-90 is factory calibrated with a fixed measurement span of 6 feet. The 4 mA position is located 72" from the transducer face. The 20 mA position is located 3.6 inches from the transducer face. Refer to the current to distance and distance to current conversion charts in step seven for reading the current output.

1. Connect a multimeter in series to read the current output.
2. Verify that as the distance from the liquid to the LVCN-90 increases, the current signal decreases.
3. Verify that as the distance from the liquid to the LVCN-90 decreases, the current signal increases.

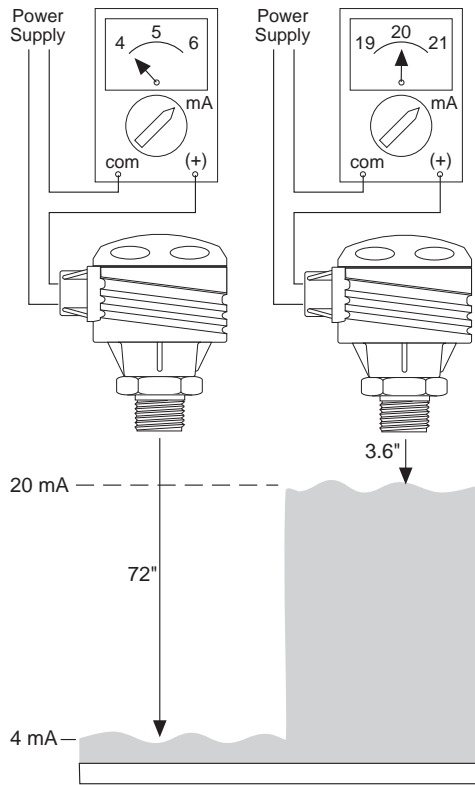

### LED Indication

The LVCN-90 features a single LED indicator which is used for power and fail-safe indication. During normal operation, the LED will be ON continuously to indicate that the transmitter has power and a strong echo signal return strength. Should the LED begin to FLASH, it indicates that the transmitter has no signal return strength and the device has gone into a fail-safe condition. During the fail-safe condition, the current will increase up to 22 mA and hold until the acoustic signal is reacquired. Once reacquired, the LED will turn back ON continuously and the current will indicate the appropriate measured value.

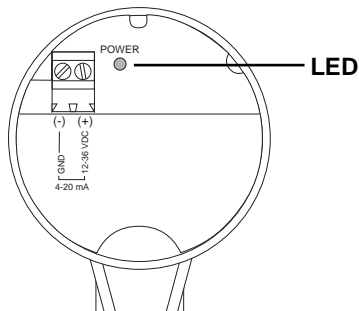

# CALIBRATION

## Step Seven

### Current to Distance Conversion Chart (Nominal)

Current mA	Distance inches	Current mA	Distance inches	Current mA	Distance inches
20	03.6	14	29.2	08	54.9
19	07.9	13	33.5	07	59.2
18	12.1	12	37.8	06	63.5
17	16.4	11	42.1	05	67.7
16	20.7	10	46.3	04	72.0
15	25.0	09	50.6		

### Distance to Current Conversion Chart (Nominal)

Distance inches	Current mA	Distance inches	Current mA	Distance inches	Current mA
3.6	20.0	30	13.8	60	06.8
06	19.4	36	12.4	66	05.4
12	18.0	42	11.0	72	04.0
18	16.6	48	09.6		
24	15.2	54	08.2		

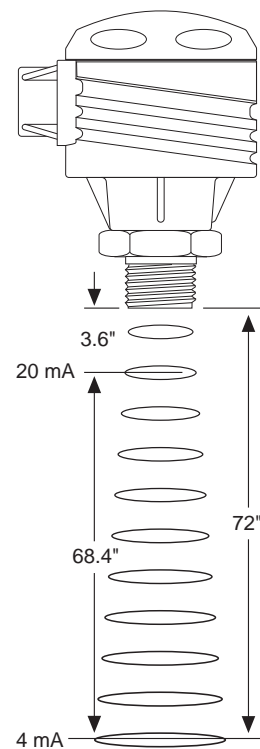

## MAINTENANCE

### Step Eight

#### General:

The LVCN-90 series level transmitter itself requires no periodic maintenance except cleaning as required. It is the responsibility of the user to determine the appropriate maintenance schedule, based on the specific characteristics of the application liquids.

#### Cleaning Procedure:

1. Power: Make Sure that all power to the transmitter, controller and/or power supply is completely disconnected.
2. Sensor Removal: In all through-wall installations, make sure that the tank is drained well below the sensor prior to removal. Carefully, remove the sensor from the installation.
3. Cleaning the Sensor: Use a soft bristle brush and mild detergent, carefully wash the transducer of the LVCN-90. Do not use harsh abrasives such as steel wool or sandpaper, which might damage the transmitter's surface. Do not use incompatible solvents which may damage the PVDF transducer or the transmitter's PP body.
4. Sensor Installation: Follow the appropriate steps of installation as outlined in the installation section of this manual.

### Step Nine

## Free Manuals Download Website

<http://myh66.com>

<http://usermanuals.us>

<http://www.somanuals.com>

<http://www.4manuals.cc>

<http://www.manual-lib.com>

<http://www.404manual.com>

<http://www.luxmanual.com>

<http://aubethermostatmanual.com>

Golf course search by state

<http://golfingnear.com>

Email search by domain

<http://emailbydomain.com>

Auto manuals search

<http://auto.somanuals.com>

TV manuals search

<http://tv.somanuals.com>