

CE

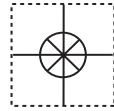

User's Guide

Shop online at

omega.com™

Ω OMEGA®

www.omega.com

e-mail: info@omega.com

ISO 9001
CERTIFIED
CORPORATE QUALITY

STAMFORD, CT

ISO 9002
CERTIFIED
CORPORATE QUALITY

MANCHESTER, UK

FP-6000 Series Flow Sensors



OMEGAnet® Online Service www.omega.com	Internet e-mail info@omega.com
---	---

Servicing North America:

USA: One Omega Drive, P.O. Box 4047
ISO 9001 Certified Stamford CT 06907-0047
TEL: (203) 359-1660 FAX: (203) 359-7700
e-mail: info@omega.com

Canada: 976 Bergar
Laval (Quebec) H7L 5A1
TEL: (514) 856-6928 FAX: (514) 856-6886
e-mail: info@omega.ca

For immediate technical or application assistance:

USA and Canada: Sales Service: 1-800-826-6342 / 1-800-TC-OMEGA®
Customer Service: 1-800-622-2378 / 1-800-622-BEST®
Engineering Service: 1-800-872-9436 / 1-800-USA-WHEN®
TELEX: 996404 EASYLINK: 62968934 CABLE: OMEGA

Mexico: En Español: (001) 203-359-7803 e-mail: espanol@omega.com
FAX: (001) 203-359-7807 info@omega.com.mx

Servicing Europe:

Benelux: Postbus 8034, 1180 LA Amstelveen, The Netherlands
TEL: +31 (0)20 3472121 FAX: +31 (0)20 6434643
Toll Free in Benelux: 0800 0993344
e-mail: nl@omega.com

Czech Republic: Rudé armády 1868, 733 01 Karviná 8
TEL: +420 (0)69 6311899 FAX: +420 (0)69 6311114
Toll Free: 0800-1-66342 e-mail: czech@omega.com

France: 9, rue Denis Papin, 78190 Trappes
TEL: +33 (0)130 621 400 FAX: +33 (0)130 699 120
Toll Free in France: 0800-4-06342
e-mail: france@omega.com

Germany/Austria: Daimlerstrasse 26, D-75392 Deckenpfronn, Germany
TEL: +49 (0)7059 9398-0 FAX: +49 (0)7056 9398-29
Toll Free in Germany: 0800 639 7678
e-mail: germany@omega.com

United Kingdom: One Omega Drive, River Bend Technology Centre
ISO 9002 Certified Northbank, Irlam, Manchester
M44 5EX United Kingdom
TEL: +44 (0)161 777 6611 FAX: +44 (0)161 777 6622
Toll Free in United Kingdom: 0800-488-488
e-mail: sales@omega.co.uk

It is the policy of OMEGA to comply with all worldwide safety and EMC/EMI regulations that apply. OMEGA is constantly pursuing certification of its products to the European New Approach Directives. OMEGA will add the CE mark to every appropriate device upon certification.

The information contained in this document is believed to be correct, but OMEGA Engineering, Inc. accepts no liability for any errors it contains, and reserves the right to alter specifications without notice.

WARNING: These products are not designed for use in, and should not be used for, patient-connected applications.

Chapter	Page	Table of Contents
1 Introduction	1	
1.1 Description	1	
1.2 Theory of Operation	1	
2 Installation and Wiring	2	
2.1 Location of Fitting	2	
2.2 Sensor Position	2	
2.3 Sensor Wiring	3	
3 Installation	4	
3.1 Hardware, Standard Sensor	4	
3.2 Hardware, Hot-Tap Sensor	4	
3.3 Standard Fitting Installation	4	
3.4 Hot-Tap Fitting Installation	5	
3.5 Calculating the H Dimension	6	
3.6 Standard Installation	8	
3.7 Hot-Tap Installation	10	
4 Sensor Removal Procedures	14	
4.1 Standard Sensor Removal	14	
4.2 Hot-Tap Sensor Removal	14	
5 Maintenance and Replacement Parts	16	
5.1 Maintenance	16	
5.2 Replacement Parts	16	
5.3 Rotor Replacement Procedure	17	
"H" Dimensions for Standard Sensors	18	
"H" Dimensions for Hot-Tap Sensors	19	
Calibration Constants	20	
Specifications	23	
Warranty	25	

Important Safety Information!

CAUTION:

(Standard version) Never remove the flow sensor from a pressurized pipe. Always wear safety face protection during sensor installation/removal.

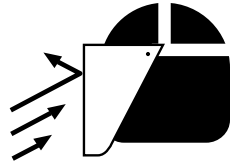

(Hot-Tap version) Follow the recommended installation/removal instructions in this manual. Always wear safety face protection during sensor installation/removal.

Pipe fittings **MUST** be installed by a certified welder only. OMEGA will not assume liability of any kind for improper fitting installations.



Serious bodily injury and/or damage to the sensor can result if the conditions and specifications presented in this manual are exceeded. **DO NOT** exceed specifications under any circumstances.



The FP-6000 Hot-Tap system's overall specifications and limitations depend on the lowest maximum rating of the components associated with the system. In other words, the Hot-Tap system is only as strong as its weakest link. For example, a ball valve, a component of the system, is rated at a maximum 100 psi @ 185 °F, limiting the entire system's maximum pressure/temperature rating to 100 psi @ 185 °F. All higher maximum specifications **MUST** yield to the component with the lowest maximum specification.



Maximum Operating Pressure:

225 psi (15 bar)

Maximum Operating Temperature:

212 °F (100 °C)



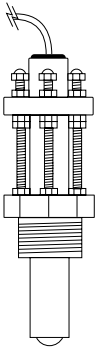

Unpacking and Inspection

Your flow sensor package includes the following items:

- OMEGA FP-6000 Series Adjustable Brass Flow Sensor
- 6 inch ruler (Standard sensor version only)
- 10 inch brass alignment rod

OMEGA FP-6000, -6001
Adjustable Brass Flow Sensor

Order Number:

FP-6000

1-1/2 in. NPT threads

FP-6001

7/1-R 1-1/2 ISO threads

Warranty Record

For your protection, record your sensor's purchase information for future reference. The serial number is located on the metal tag attached to the upper portion of the sensor body.

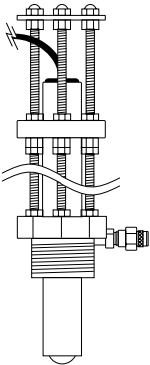

OMEGA FP-6002, -6003
Adjustable Brass Flow Sensor
for Hot-Tap installations

Order Number:

FP-6002

1-1/2 in. NPT threads

FP-6003

7/1-R 1-1/2 ISO threads

Type: OMEGA FP-6000 Series
Adjustable Brass Flow Sensor

Purchase Date: _____

Model Number: _____

Serial Number: _____

Purchased From: _____

Purchase Order Number: _____

Chapter 1

Introduction

This manual contains description, specifications and instruction for the installation, removal, and operation of the OMEGA FP-6000 Series Adjustable Brass Flow Sensor. Please read the manual thoroughly. If you require further assistance, please contact your OMEGA dealer.

1.1 Description

The FP-6000 Series is an insertion flow sensor used to measure the flow velocity of fluids through process pipes. The sensor insertion depth is adjustable, allowing installation into metal pipes ranging from 1 1/2 to 24 inches in diameter (1 1/2 to 36 in. for Hot-Tap). The Hot-Tap version enables installation in active pipes, reducing downtime to a minimum. Wetted parts include C36000 brass, CD4MCu steel, tungsten steel, Fluoroloy B, and Viton®.

The FP-6000 Series mounts on the pipe through any standard 1 1/2 inch female pipe fitting. The unit comes equipped with standard NPT threads or optional ISO 7/1-R 1 1/2 threads.

1.2 Theory of Operation

Liquid flowing through a process pipe rotates the sensor paddlewheel. An AC frequency is induced into the sensor coil which is proportional to the fluid velocity in amplitude and frequency. The AC signal is then input to a control instrument where the frequency is converted to engineering units and used to display flow rate and control external devices.

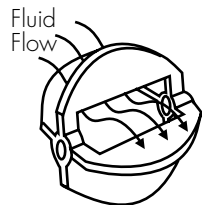

Patented open-cell rotor design provides a linear AC output over a wider velocity range.

Chapter 2

Installation and Wiring

The linearity and accuracy of the FP-6000 Series sensor depend on predictable flow conditions in the pipe and proper location of the fitting. As with any insertion flow sensor, the pipe must be full and generally free of air pockets.

2.1 Location of Fitting

The sensor must be located in a free-flowing straight run of pipe. OMEGA recommends a **minimum** of 10 pipe diameters of straight pipe upstream and a **minimum** of 5 diameters downstream to insure a fully developed flow profile. Any obstructions to the flow will require considerably longer straight runs. Figure 1 illustrates several common situations and recommended piping distances.

Figure 1

*Sensor upstream/
downstream mounting
requirements*

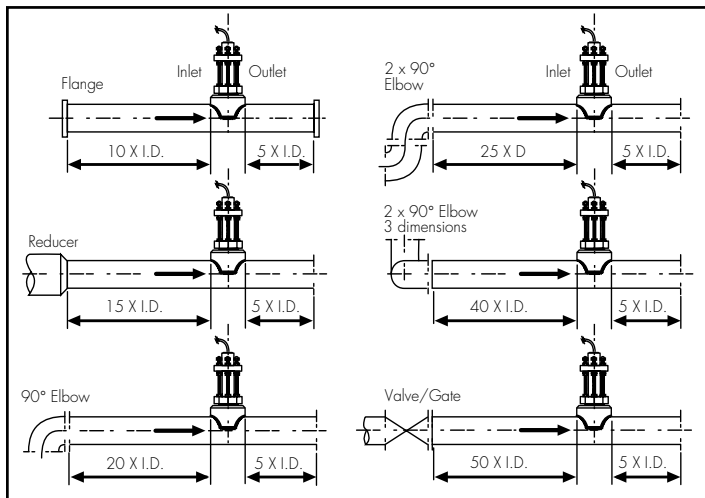

2.2 Sensor Position

When installing the sensor in a horizontal pipe run the optimum position is at 0° or 180°, assuming the line is always full and contains no solids.

Air pockets or sediment in the line will disturb the rotation of the paddlewheel, causing inaccuracy in the calibration. Installing the sensor at an angle

(max. 30°) will help to avoid these problem areas, but use caution. Excessive angles will cause bearing drag at lower flow rates.

On a vertical pipe run locate the sensor where the flow is upward. If downward flow is necessary the system must be designed to prevent air/water vapor pockets from developing in the pipe which will affect the performance of the sensor.

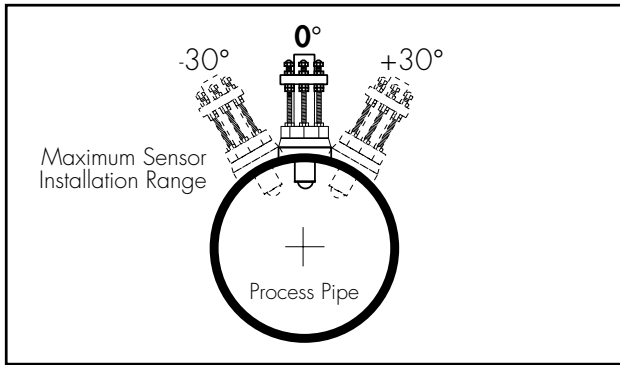

Figure 2

Sensor Installation Range

Vertical mounting is recommended to provide best overall performance.

Special Considerations

For Hot-Tap installations allow at least 3 feet of vertical clearance for sensor installation plus the distance required for the isolation valve and fittings attached to the pipe. More clearance may be necessary to suit the drilling machine used during sensor installation.

2.3 Sensor Wiring

Both Standard and Hot-Tap sensor versions include 25 feet of cable. The cable may be extended up to 200 feet without amplification. A 1/2 inch conduit port is available in the sensor to install the cable in protective conduit.

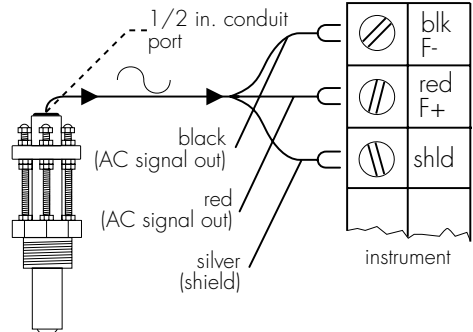

Chapter 3

Installation

The following items are required to properly install the OMEGA FP-6000 Series Adjustable Brass flow sensor.

3.1 Hardware, Standard Sensor

- female pipe fitting (weld-on or saddle)
1 1/2 in. NPT or ISO 7/1-Rc 1-1/2
- 1 1/4 in. (32 mm) diameter drill
- Pipe thread sealant
- Tape measure

3.2 Hardware, Hot-Tap Sensor

The Hot-Tap sensor requires all the above items plus:

- Hot-Tap drilling machine (e.g. Mueller drilling machine or equivalent)
- Female ball or gate valve (full port only)
1 1/2 in. NPT or ISO 7/1-Rc 1-1/2
- Male pipe nipple, 1 1/2 x 2 in./32 x 50 mm
1 1/2 in. NPT or ISO 7/1-R 1 1/2
- Hot-Tap installation tool (purchased separately)



Caution: Depressurize and drain pipe before drilling .

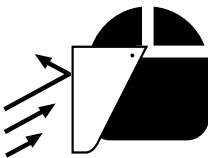

3.3 Standard Fitting Installation

1. Depressurize and drain pipe.
2. Wearing safety face protection, drill a 1 1/4 in. (32 mm) diameter hole in the pipe.
3. Install the pipe fitting on the outside of the pipe according to the manufacturer's instructions. Failure to follow these instructions may result in bodily injury and/or product failure.

4. Remove brass sensor nut from sensor.

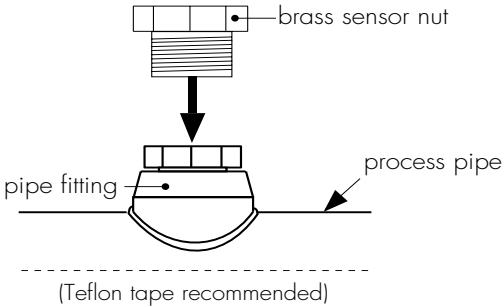

5. Thread brass sensor nut into pipe fitting.

3.4 Hot-Tap Fitting Installation

1. Install the pipe fitting on the outside diameter of the pipe according to the manufacturer's instructions. Failure to follow these instructions may result in bodily injury and/or product failure.

2. Install the pipe nipple and isolation valve (ball or gate valve) onto the external pipe fitting using pipe sealant on the threads.

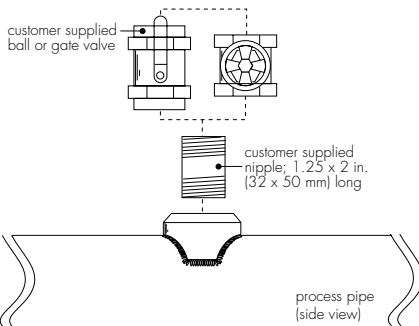

3. Wearing safety face protection, install an appropriate hole cutting tool per manufacturers instructions (e.g. Mueller drilling machine) with a 1 1/4 in. (32 mm) drill onto the top of the isolation valve, ensuring a tight fit. **Use the recommended drill bit size or damage to the isolation valve may occur.**

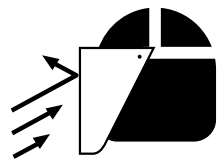

4. Open the isolation valve and insert the drill through the valve and cut the sensor clearance hole. After the hole is cut, withdraw the drill from the isolation valve and close the valve. Remove the drilling machine per manufacturer's instructions.

5. Install brass sensor nut/bleed valve into the top of the isolation valve. Make sure the bleed valve clears the handle of the isolation valve during operation.

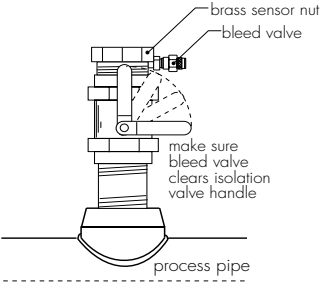

3.5 Calculating the H Dimension

Before installing the sensor some critical dimensions must be established. The rotor shaft must be located 10% inside the pipe I.D. to insure accurate calibration capability. To accomplish this, the "H" dimension is measured from the outside surface of the pipe to the bottom of the sensor flange.

Nominal "H" dimensions for standard pipes are listed on page 18-19. For irregular pipe dimensions, calculate the "H" dimension using the given formulas (page 7). The 6 inch ruler may be used to measure the I.D. and wall thickness of pipes up to 5 inch (standard sensors only).

Wall thickness: _____

I.D.: _____

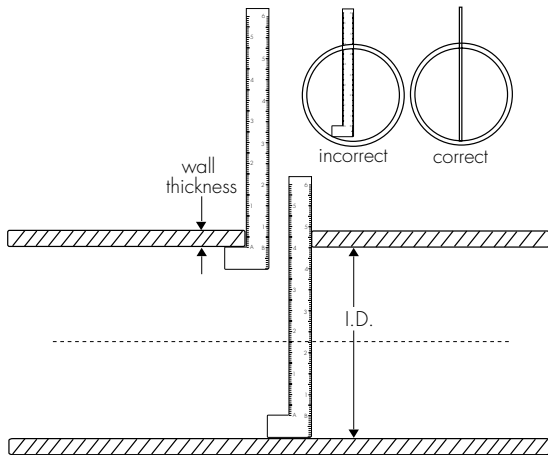

For standard sensor installations, the ruler may be used to measure wall thickness and I.D. of pipes up to 5 inches in diameter.

Standard Sensor

$H = 5.95 - \text{pipe wall thickness} - (0.10 \times \text{I.D.})$

Record your pipes "H" dimension for future reference:

Example:

3.0 inch schedule 80 wrought steel;

Wall thickness= 0.3 in.

Inside diameter = 2.9 in.

H= _____

$H = 5.95 - 0.3 - (0.10 \times 2.9)$

$H = 5.36 \text{ in.}$

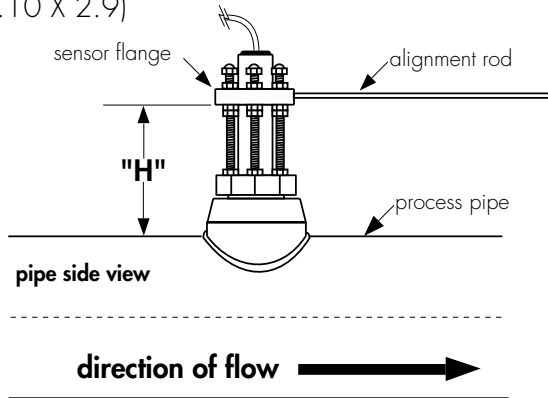

Hot-Tap Sensor

$H = 15.00 - \text{pipe wall thickness} - (0.10 \times \text{I.D.})$

Example:

10 inch schedule 40 wrought steel;

Wall thickness= 0.365 in.

Inside diameter = 10.02 in.

$H = 15.00 - 0.365 - (0.10 \times 10.02)$

$H = 13.633 \text{ in.}$

Record your pipes "H" dimension for future reference:

H= _____

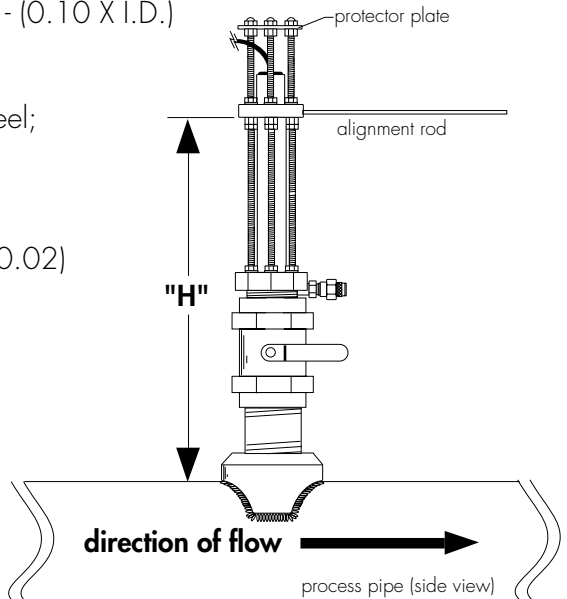

Once the correct dimensions are calculated and recorded, the sensor can be installed in the fitting. The Standard and Hot-Tap versions require substantially different procedures.

3.6 Standard Installation

1. Thread one hex nut onto each of the three threaded rods included in package. Install threaded rod with a lock-washer onto the brass sensor nut. Secure rods in place by tightening each hex nut against the brass sensor nut.

2. Thread one jam nut and lower hex nut onto each stud so that the top surface of each nut is at the proper "H" dimension for your pipe. Secure each hex nut with a jam nut.

3. Insert the flow sensor into the brass sensor nut, making sure the alignment hole on the sensor flange is pointing downstream.

Step 1

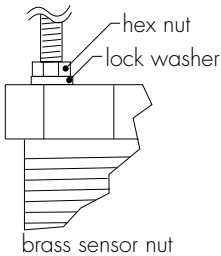

Step 2

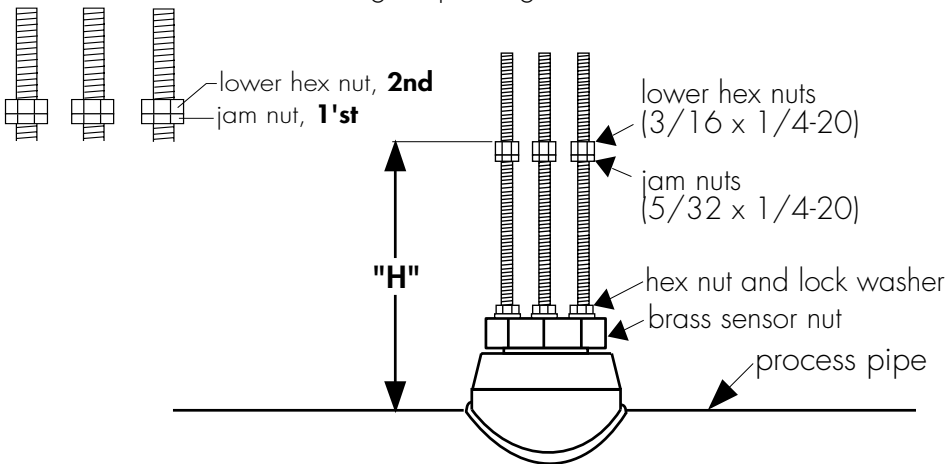

4. Place the alignment rod in the hole on the sensor flange. Align the flange so rod is parallel to the process pipe.

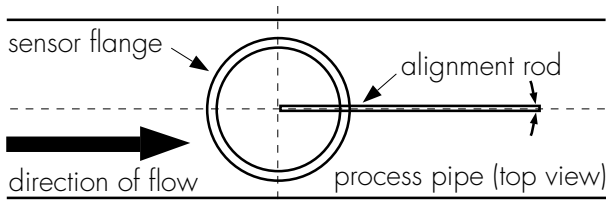

The flow sensor alignment rod MUST be parallel to the process pipe as shown.

5. Thread upper hex nuts with lock-washers until they contact the sensor flange and tighten. Check for proper "H" dimension and readjust if necessary.

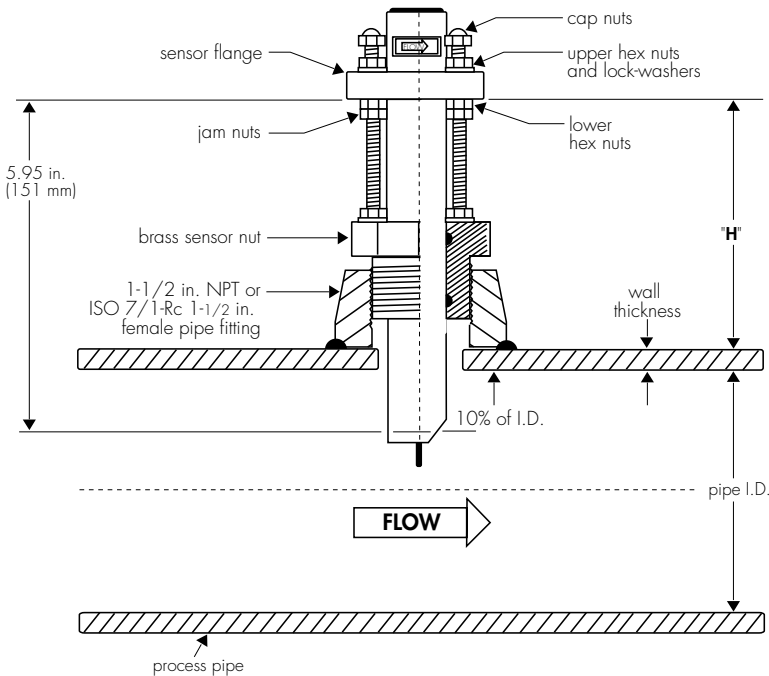

3.7 Hot-Tap Installation

Step 1

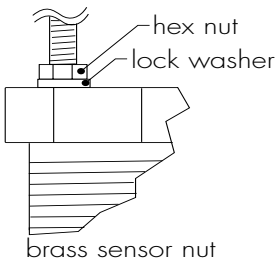

1. Thread one hex nut onto each of the three threaded rods included in package. Install threaded rod with a lock-washer onto the brass sensor nut. Secure rods in place by tightening each hex nut against the brass sensor nut.

2. Thread one jam nut and lower hex nut onto each stud so the top surface of each nut is 13.75 in. (350 mm) from top surface of brass sensor nut. Secure each hex nut with a jam nut.

This setting is critical to ensure an adequate sensor seal and to prevent the rotor from hitting the isolation valve orifice during installation.

Step 2

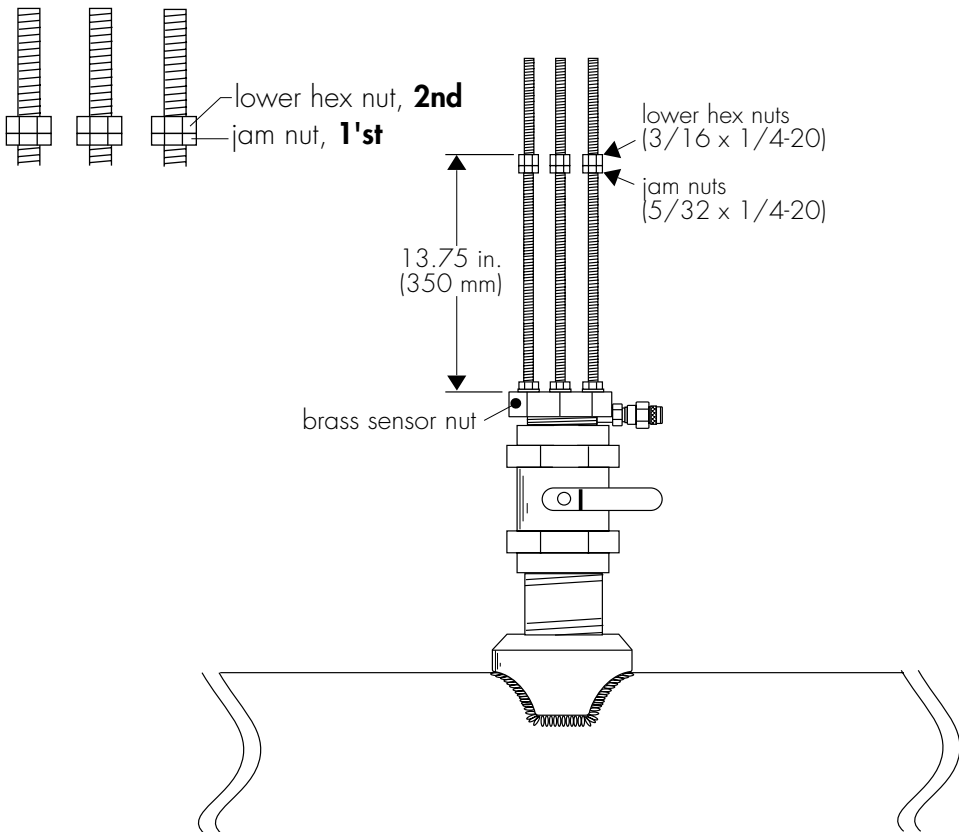

3. Wipe the FP-6000 Series sensor body with a dry, clean cloth. Orient the alignment hole on the sensor flange to point **downstream**. Place the slotted flange over the threaded rods. Lower the sensor into fitting until the sensor flange rests on the lower hex and jam nuts.

4. Secure the sensor with lock-washers and upper hex nuts on the top of the flange. Before tightening, align the sensor flange so that the alignment rod is parallel and level with the process pipe.

5. Make sure the bleed valve is closed (full clockwise position).

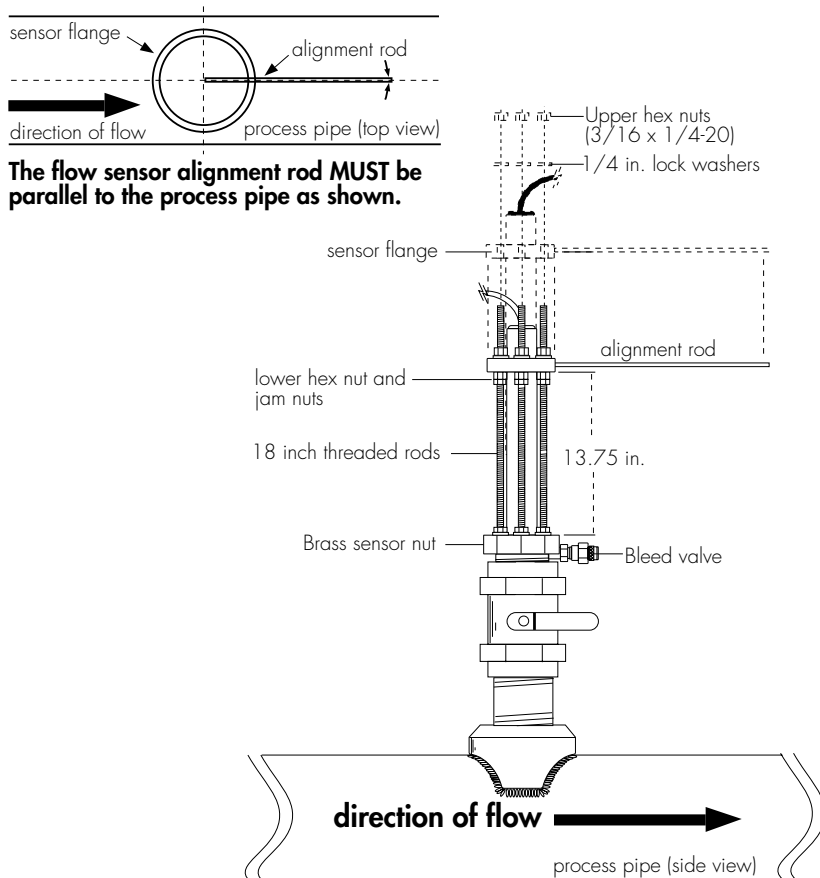

Using the Hot-Tap Installation Tool

The Hot-Tap installation tool helps to lower the sensor into place against the pressure in the pipe.

1. Thread protector plate hex nuts onto each of the three threaded rods. Adjust each hex to a height of approximately 1 in. (25 mm) from the top of each rod. Remove the black plastic cable grommet in top of sensor with a screwdriver. Slide the grommet up the cable away from sensor.

2. Position the installation tool bearing plate by rotating it so that it is approximately 2 inches away from the swivel mount. Mount the installation tool by placing the threaded rods through the holes in the tool's bearing plate, resting the bearing plate on top of the protector plate hex nuts. Make sure the swivel mount's ears are mounted **between** the threaded rods (not over the rods). Install the bearing plate cap nuts. Tighten the bearing plate cap nuts to secure the installation tool in place.

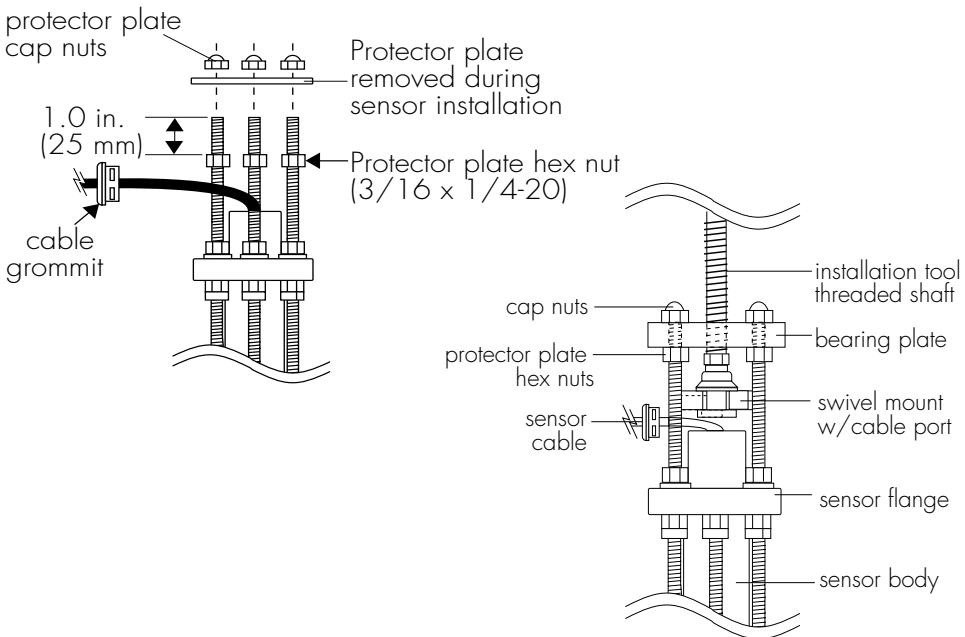

3. Align the sensor cable with the swivel mount cable port to prevent cable pinching. Use a 3/8 inch wrench or socket to turn the installation tool shaft clockwise until it is seated in the hole at the top of the sensor flange.

4. Wearing safety face protection, **slowly open the isolation valve to the full open position.**

Loosen the lower hex and jam nuts and move them to the required "H" dimension. Turn the installation tool shaft **clockwise** until the sensor flange contacts the lower hex and jam nuts. Thread the upper hex nuts down until they contact the sensor flange. Tighten the upper hex nuts to secure the sensor.

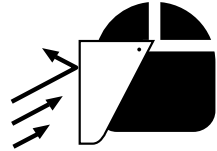

5. Remove cap nuts and withdraw the installation tool by turning shaft **counterclockwise**. Be careful to not damage cable. Snap cable grommet into top of sensor and replace protector plate and cap nuts.

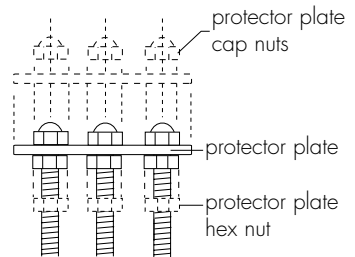
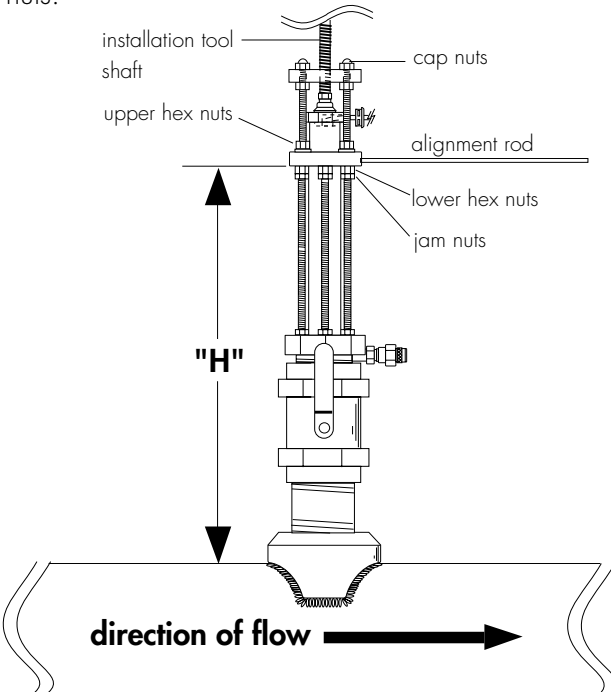

Chapter 4

Sensor Removal Procedures

4.1 Standard Sensor Removal

To remove the Standard FP-6000 Series sensor from a depressurized empty pipe, simply remove the cap nuts and upper hex nuts located above the sensor flange. Pull up on sensor flange with twisting motion.

4.2 Hot-Tap Sensor Removal

To remove the Hot-Tap sensor safely from a pressurized active pipe, the entire installation process must be reversed.

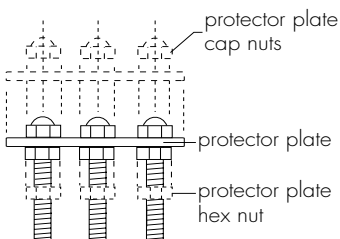

1. Remove the cap nuts, protector plate, protector plate hex nuts, and sensor cable grommet.

2. Thread installation tool in place and secure bearing plate in place of sensor protector plate.

3. Turn shaft of installation tool **clockwise** to lower tool into opening in sensor flange. Guide cable into the port to prevent damage.

4. Wearing safety face protection, loosen the upper hex nuts and raise to 14.2 in. (361 mm) from top of brass sensor nut to bottom of nut. **This measurement is critical to maintain watertight seal in sensor while allowing clearance to close the isolation valve.**

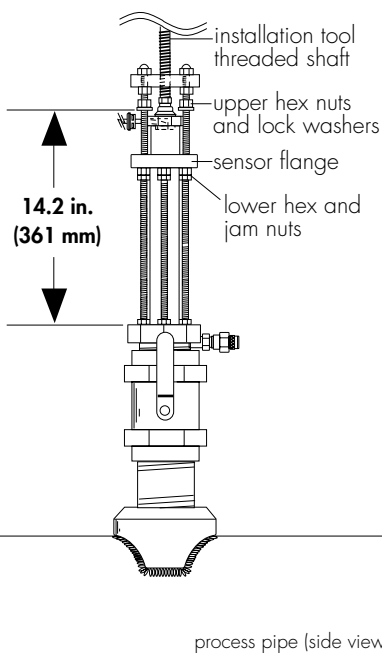
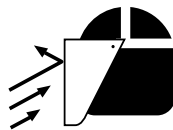

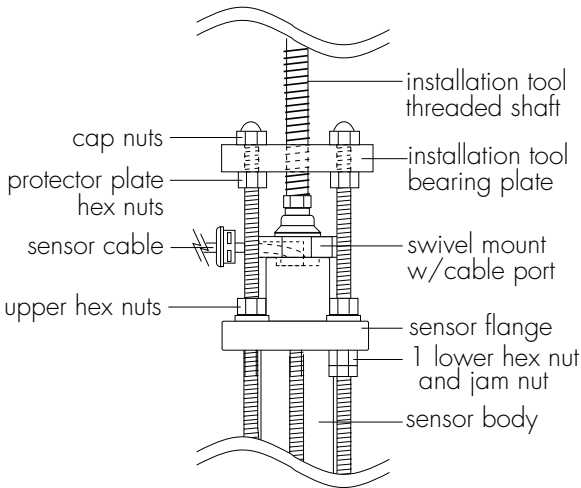

5. Wearing safety face protection, turn the installation tool shaft **counterclockwise** to withdraw sensor until the sensor flange contacts the upper hex nuts.

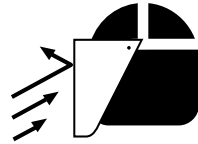

6. Raise **one** lower hex and jam nut to bottom of sensor flange.

7. Close valve, remove bearing plate and tool.

To remove the sensor

8. Wearing safety face protection, cover the bleed valve with suitable protection (rag, towel, etc.) and open the bleed valve (ccw rotation) to relieve internal pressure. Pull sensor up until bleed valve purges some fluid (indicating sensor is past 1st o-ring seal inside brass sensor nut) then remove sensor from brass sensor nut/threaded rod assembly.

When reinstalling the

sensor: leave one lower hex nut in position to guide sensor to proper height before opening valve. Return to "H" dimension height after valve is opened.

Caution: In case of a leaky isolation valve, the sensor will be under a slight amount of pressure. Care should be taken when removing the sensor. Use the bleed valve to relieve this pressure taking care not to spray fluid on yourself or others.



Chapter 5

Maintenance and Replacement Parts

5.1 Maintenance

All versions of the FP-6000 series sensor require little or no maintenance, with the exception of an occasional sensor/paddlewheel cleaning.

5.2 Replacement Parts

(Standard version)

1. Standard sensor assembly FP-6000, -6001
2. Rotor kit (bearings, shaft, retainers, and rotor included), see table below♦
 - FP52509-1 kit with stainless steel shaft
 - FP52509-2 kit with Tungsten Carbide shaft
3. Instruction manual M-2973

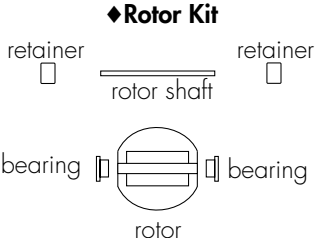
<p>♦Rotor Kit</p>  <p>retainer retainer rotor shaft</p> <p>bearing bearing rotor</p> <p><i>Refer to rotor replacement instructions, pg# 17</i></p>	<p>FP52509-1 Rotor Kit</p> <ul style="list-style-type: none">• Retainer material: 316 stainless steel• Rotor shaft material: 316 stainless steel• Bearing material: Fluoroloy B• Rotor material: CD4MCu stainless steel <p>FP52509-2 Rotor Kit</p> <ul style="list-style-type: none">• Retainer material: 316 stainless steel• Rotor shaft material: Tungsten Carbide• Bearing material: Fluoroloy B• Rotor material: CD4MCu stainless steel
---	--

(Hot-Tap version)

4. Hot-Tap sensor assembly FP-6000, -6001
5. Rotor kit (bearings, shaft, retainers, and rotor included), see table above♦
 - FP52509-1 kit with stainless steel shaft
 - FP52509-2 kit with Tungsten Carbide shaft
6. Instruction manual M-2973

5.3 Rotor Replacement Procedure

1. With a small pair of needle-nose pliers, firmly grip the center of the rotor pin (axle) and with a twisting motion, bend the rotor pin into an "S" shape. This should pull the ends of the pin out of the shaft retainers and free the rotor assembly.

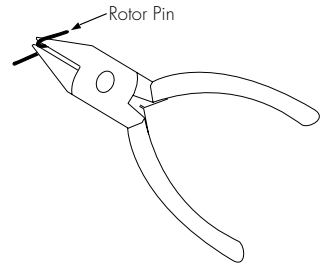

2. Remove shaft retainer from each side by gently tapping it inwards using a punch. Install a new shaft retainer with the rotor shaft clearance hole inward. **Only install one shaft retainer at this time.**

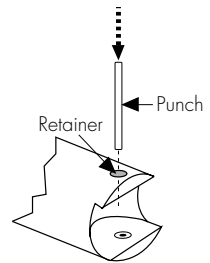

3. Insert the new rotor assembly and bearings into the rotor housing of the sensor and place the new rotor pin (axle) through the open end of the rotor housing, through the rotor and bearings, and into the previously installed shaft retainer.

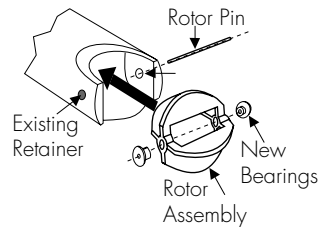

4. Tap the second shaft retainer (rotor shaft clearance hole inwards) into the hole while lining up the rotor pin with the center of the shaft retaining hole. **This completes the rotor replacement procedure.**

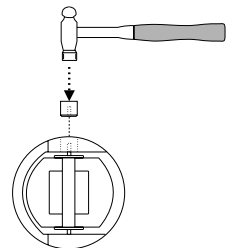

H Dimensions

H Dimensions for Standard Sensors

Wrought Steel Pipe Per ANSI 36.10

<u>NPS</u>	<u>SCH 40</u>	<u>SCH 80</u>	<u>STD</u>	<u>XS</u>
1-1/2 in.	5.644 in.	5.600 in.	5.644 in.	5.600 in.
2 in.	5.589 in.	5.538 in.	5.589 in.	5.538 in.
2-1/2 in.	5.500 in.	5.442 in.	5.500 in.	5.442 in.
3 in.	5.427 in.	5.360 in.	5.427 in.	5.360 in.
3-1/2 in.	5.369 in.	5.296 in.	5.369 in.	5.296 in.
4 in.	5.310 in.	5.230 in.	5.310 in.	5.230 in.
5 in.	5.187 in.	5.094 in.	5.187 in.	5.094 in.
6 in.	5.064 in.	4.942 in.	5.064 in.	4.942 in.
8 in.	4.830 in.	4.688 in.	4.830 in.	4.688 in.
10 in.	4.583 in.	4.400 in.	4.583 in.	4.475 in.
12 in.	4.350 in.	4.125 in.	4.375 in.	4.275 in.
14 in.	4.200 in.	3.950 in.	4.250 in.	4.150 in.
16 in.	3.950 in.	3.675 in.	4.050 in.	3.950 in.
18 in.	3.700 in.	3.400 in.	3.850 in.	3.750 in.
20 in.	3.475 in.	3.125 in.	3.650 in.	3.550 in.
22 in.	*	2.850 in.	3.450 in.	3.350 in.
24 in..	3.000 in.	2.575 in.	3.250 in.	3.150 in.

Conversion:

mm = inches (25.4)

Stainless Steel Pipe Per ANSI B36.19

<u>NPS</u>	<u>SCH 5S</u>	<u>SCH 10S</u>	<u>SCH 40S</u>	<u>SCH 80S</u>
1-1/2 in.	5.708 in.	5.673 in.	5.644 in.	5.600 in.
2 in.	5.660 in.	5.625 in.	5.589 in.	5.538 in.
2-1/2 in.	5.596 in.	5.567 in.	5.500 in.	5.442 in.
3 in.	5.534 in.	5.504 in.	5.427 in.	5.360 in.
3-1/2 in.	5.484 in.	5.454 in.	5.369 in.	5.296 in.
4 in.	5.434 in.	5.404 in.	5.310 in.	5.230 in.
5 in.	5.306 in.	5.287 in.	5.187 in.	5.094 in.
6 in.	5.200 in.	5.180 in.	5.064 in.	4.942 in.
8 in.	5.000 in.	4.969 in.	4.830 in.	4.688 in.
10 in.	4.768 in.	4.743 in.	4.583 in.	4.475 in.
12 in.	4.550 in.	4.531 in.	4.375 in.	4.275 in.
14 in.	4.425 in.	4.400 in.	*	*
16 in.	4.218 in.	4.200 in.	*	*
18 in.	4.018 in.	4.000 in.	*	*
20 in.	3.800 in.	3.776 in.	*	*
22 in.	3.600 in.	3.576 in.	*	*
24 in.	3.376 in.	3.350 in.	*	*

(*) represents values currently unavailable

H Dimensions for Hot-Tap Sensors

H Dimensions

Wrought Steel Pipe Per ANSI 36.10

<u>NPS</u>	<u>SCH 40</u>	<u>SCH 80</u>	<u>STD</u>	<u>XS</u>
1-1/2 in.	14.694 in.	14.650 in.	14.694 in.	14.650 in.
2 in.	14.639 in.	14.588 in.	14.639 in.	14.588 in.
2-1/2 in.	14.550 in.	14.492 in.	14.550 in.	14.492 in.
3 in.	14.477 in.	14.410 in.	14.477 in.	14.410 in.
3-1/2 in.	14.419 in.	14.346 in.	14.419 in.	14.346 in.
4 in.	14.360 in.	14.280 in.	14.360 in.	14.280 in.
5 in.	14.237 in.	14.144 in.	14.237 in.	14.144 in.
6 in.	14.144 in.	13.992 in.	14.144 in.	13.992 in.
8 in.	13.880 in.	13.738 in.	13.880 in.	13.738 in.
10 in.	13.633 in.	13.450 in.	13.633 in.	13.525 in.
12 in.	13.400 in.	13.175 in.	13.425 in.	13.325 in.
14 in.	13.250 in.	13.000 in.	13.300 in.	13.200 in.
16 in.	13.000 in.	12.725 in.	13.100 in.	13.000 in.
18 in.	12.750 in.	12.450 in.	12.900 in.	12.800 in.
20 in.	12.525 in.	12.175 in.	12.700 in.	12.600 in.
22 in.	*	11.900 in.	12.500 in.	12.400 in.
24 in.	12.050 in.	11.625 in.	12.300 in.	12.200 in.

Conversion:

mm = inches (25.4)

Stainless Steel Pipe Per ANSI B36.19

<u>NPS</u>	<u>SCH 5S</u>	<u>SCH 10S</u>	<u>SCH 40S</u>	<u>SCH 80S</u>
1-1/2 in.	14.758 in.	14.723 in.	14.694 in.	14.650 in.
2 in.	14.711 in.	14.675 in.	14.639 in.	14.588 in.
2-1/2 in.	14.646 in.	14.617 in.	14.550 in.	14.492 in.
3 in.	14.584 in.	14.554 in.	14.477 in.	14.410 in.
3-1/2 in.	14.534 in.	14.504 in.	14.419 in.	14.346 in.
4 in.	14.484 in.	14.454 in.	14.360 in.	14.280 in.
5 in.	14.357 in.	14.337 in.	14.237 in.	14.144 in.
6 in.	14.250 in.	14.230 in.	14.144 in.	13.992 in.
8 in.	14.050 in.	14.019 in.	13.880 in.	13.738 in.
10 in.	13.818 in.	13.793 in.	13.633 in.	13.525 in.
12 in.	13.600 in.	13.581 in.	13.425 in.	13.325 in.
14 in.	13.475 in.	13.450 in.	*	*
16 in.	13.268 in.	13.250 in.	*	*
18 in.	13.068 in.	13.050 in.	*	*
20 in.	12.850 in.	12.826 in.	*	*
22 in.	12.650 in.	12.626 in.	*	*
24 in.	12.426 in.	12.400 in.	*	*

(*) represents values currently unavailable

K-factors Stainless Steel

SCH 5S STAINLESS STEEL PIPE PER ANSI B36.19

	K-FACTOR	K-FACTOR	A-FACTOR	A-FACTOR
PIPE SIZE	PULSES/ U.S. GAL	PULSES/ LITER	U.S. GPM/HZ	LPM/HZ
1 1/2	104.200	27.5297	0.5758	2.1795
2	67.160	17.7437	0.8934	3.3815
2 1/2	46.060	12.1691	1.3026	4.9305
3	29.790	7.8705	2.0141	7.6234
3 1/2	22.060	5.8283	2.7199	10.295
4	16.890	4.4624	3.5524	13.446
5	10.6500	2.8137	5.6338	21.324
6	7.1160	1.8801	8.4317	31.914
8	3.8700	1.0225	15.504	58.682
10	2.3570	0.6227	25.456	996.35
12	1.6060	0.4243	37.360	141.41
14	1.2980	0.3429	46.225	174.96
16	0.9620	0.2542	62.370	236.07
18	0.7400	0.1955	81.081	306.89
20	0.5900	0.1559	101.695	384.92
22	0.4790	0.1266	125.26	474.11
24	0.3990	0.1054	150.38	569.17

SCH 10S STAINLESS STEEL PIPE PER ANSI B36.19

	K-FACTOR	K-FACTOR	A-FACTOR	A-FACTOR
PIPE SIZE	PULSES/ U.S. GAL	PULSES/ LITER	U.S. GPM/HZ	LPM/HZ
1 1/2	113.600	30.0132	0.5282	1.9991
2	72.560	19.1704	0.8269	3.1298
2 1/2	48.750	12.8798	1.2308	4.6585
3	31.250	8.2563	1.9200	7.2672
3 1/2	23.010	6.0793	2.6076	9.9870
4	17.540	4.6341	3.4208	12.948
5	10.8700	2.8719	5.5198	20.892
6	7.2410	1.9131	8.2861	31.363
8	3.9520	1.0441	15.182	57.465
10	2.3880	0.6309	25.126	995.10
12	1.6200	0.4280	37.037	140.19
14	1.3110	0.3464	45.767	173.23
16	0.9680	0.2557	61.983	234.61
18	0.7440	0.1966	80.645	305.24
20	0.5930	0.1567	101.180	382.97
22	0.4820	0.1273	124.48	471.16
24	0.4020	0.1062	149.25	564.93

SCH 40S STAINLESS STEEL PIPE PER ANSI B36.19

	K-FACTOR	K-FACTOR	A-FACTOR	A-FACTOR
PIPE SIZE	PULSES/ U.S. GAL	PULSES/ LITER	U.S. GPM/HZ	LPM/HZ
1 1/2	122.000	32.2325	0.4918	1.8615
2	78.690	20.7900	0.7625	2.8860
2 1/2	55.630	14.6975	1.0786	4.0823
3	35.530	9.3871	1.6887	6.3918
3 1/2	26.070	6.8877	2.3015	8.7111
4	19.840	5.2417	3.0242	11.447
5	12.090	3.1942	4.9628	18.784
6	8.0410	2.1244	7.4618	28.243
8	4.3500	1.1493	13.793	52.207
10	2.6080	0.6890	23.006	87.078
12	1.7400	0.4597	34.483	130.52
14	*	*	*	*
16	*	*	*	*
18	*	*	*	*
20	*	*	*	*
22	*	*	*	*
24	*	*	*	*

SCH 80S STAINLESS STEEL PIPE PER ANSI B36.19

	K-FACTOR	K-FACTOR	A-FACTOR	A-FACTOR
PIPE SIZE	PULSES/ U.S. GAL	PULSES/ LITER	U.S. GPM/HZ	LPM/HZ
1 1/2	136.100	35.9577	0.4409	1.6686
2	88.590	23.4055	0.6773	2.5635
2 1/2	62.810	16.5945	0.9553	3.6157
3	39.990	10.5654	1.5004	5.6789
3 1/2	29.220	7.7199	2.0534	7.7721
4	22.160	5.8547	2.7076	10.248
5	13.420	3.5456	4.4709	16.923
6	9.0160	2.3820	6.6548	25.189
8	4.8190	1.2732	12.451	47.126
10	2.7730	0.7326	21.637	81.897
12	1.8240	0.4819	32.895	124.51
14	*	*	*	*
16	*	*	*	*
18	*	*	*	*
20	*	*	*	*
22	*	*	*	*
24	*	*	*	*

K-factors Wrought Steel

STD WROUGHT STEEL PIPE PER ANSI B36.10				
	K-FACTOR	K-FACTOR	A-FACTOR	A-FACTOR
PIPE SIZE	PULSES/ U.S. GAL	PULSES/ LITER	U.S. GPM/HZ	LPM/HZ
1 1/2	122.000	32.2325	0.4918	1.8615
2	78.690	20.7900	0.7625	2.8860
2 1/2	55.630	14.6975	1.0786	4.0823
3	35.530	9.3871	1.6887	6.3918
3 1/2	26.070	6.8877	2.3015	08.711
4	19.840	5.2417	3.0242	11.447
5	12.090	3.1942	4.9628	18.784
6	8.0410	2.1244	7.4618	28.243
8	4.3500	1.1493	13.793	52.207
10	2.6080	0.6890	23.006	87.078
12	1.7400	0.4597	34.483	130.52
14	1.3950	0.3686	43.011	162.80
16	1.0220	0.2700	58.708	222.21
18	0.7800	0.2061	76.923	291.15
20	0.6150	0.1625	97.561	369.27
22	0.4970	0.1313	120.72	456.94
24	0.4110	0.1086	145.99	552.55

XS WROUGHT STEEL PIPE PER ANSI B36.10				
	K-FACTOR	K-FACTOR	A-FACTOR	A-FACTOR
PIPE SIZE	PULSES/ U.S. GAL	PULSES/ LITER	U.S. GPM/HZ	LPM/HZ
1 1/2	136.100	35.9577	0.4409	1.6686
2	88.590	23.4055	0.6773	2.5635
2 1/2	62.810	16.5945	0.9553	3.6157
3	39.990	10.5654	1.5004	5.6789
3 1/2	29.220	7.7199	2.0534	7.7721
4	22.160	5.8547	2.7076	10.248
5	13.420	3.5456	4.4709	16.923
6	9.0160	2.3820	6.6548	25.189
8	4.8190	1.2732	12.451	47.126
10	2.7730	0.7326	21.637	81.897
12	1.8240	0.4819	32.895	124.51
14	1.4550	0.3844	41.237	156.08
16	1.0590	0.2798	56.657	214.45
18	0.8050	0.2127	74.534	282.11
20	0.6320	0.1670	94.937	359.34
22	0.5100	0.1347	117.65	445.29
24	0.4200	0.1110	142.86	540.71

SCH 40 WROUGHT STEEL PIPE PER ANSI B36.10				
	K-FACTOR	K-FACTOR	A-FACTOR	A-FACTOR
PIPE SIZE	PULSES/ U.S. GAL	PULSES/ LITER	U.S. GPM/HZ	LPM/HZ
1 1/2	122.000	32.232	0.4918	1.8615
2	78.690	20.790	0.7625	2.8860
2 1/2	55.630	14.697	1.0786	4.0823
3	35.530	9.3871	1.6887	6.3918
3 1/2	26.070	6.8877	2.3015	08.711
4	19.840	5.2417	3.0242	11.447
5	12.090	3.1942	4.9628	18.784
6	8.0410	2.1244	7.4618	28.243
8	4.3500	1.1493	13.793	52.207
10	2.6080	0.6890	23.006	87.078
12	1.7610	0.4653	34.072	128.96
14	1.4250	0.3765	42.105	159.37
16	1.0590	0.2798	56.657	214.45
18	0.8180	0.2161	73.350	277.63
20	0.6460	0.1707	92.879	351.55
22	*	*	*	*
24	0.4350	0.1149	137.93	522.07

SCH 80 WROUGHT STEEL PIPE PER ANSI B36.10				
	K-FACTOR	K-FACTOR	A-FACTOR	A-FACTOR
PIPE SIZE	PULSES/ U.S. GAL	PULSES/ LITER	U.S. GPM/HZ	LPM/HZ
1 1/2	136.100	35.9577	0.4409	1.6686
2	88.590	23.4055	0.6773	2.5635
2 1/2	62.810	16.5945	0.9553	3.6157
3	39.990	10.5654	1.5004	5.6789
3 1/2	29.220	7.7199	2.0534	7.7721
4	22.160	5.8547	2.7076	10.248
5	13.420	3.5456	4.4709	16.923
6	9.0160	2.3820	6.6548	25.189
8	4.8190	1.2732	12.451	47.126
10	2.8970	0.7654	20.711	78.391
12	1.9620	0.5184	30.581	115.75
14	1.5890	0.4198	37.760	142.92
16	1.1750	0.3104	51.064	193.28
18	0.9040	0.2388	66.372	251.22
20	0.7160	0.1892	83.799	317.18
22	0.5820	0.1538	103.093	390.21
24	0.4820	0.1273	124.48	471.16

K-factors Plastic Pipe

	K-FACTOR	K-FACTOR	A-FACTOR	A-FACTOR
PIPE	PULSES/	PULSES/	U.S.	
SIZE	U.S. GAL	LITER	GPM/HZ	LPM/HZ
1 1/2	124.400	32.8666	0.4823	1.8256
2	80.140	21.1731	0.7487	2.8338
2 1/2	56.730	14.9881	1.0576	4.0032
3	36.180	9.5588	1.6584	6.2769
3 1/2	26.500	7.0013	2.2642	8.5698
4	20.140	5.3210	2.9791	11.276
5	12.250	3.2365	4.8980	18.539
6	8.1430	2.1514	7.3683	27.889
8	4.3980	1.1620	13.643	51.637
10	2.6340	0.6959	22.779	86.219
12	1.7770	0.4695	33.765	127.80

	K-FACTOR	K-FACTOR	A-FACTOR	A-FACTOR
PIPE	PULSES/	PULSES/	U.S.	
SIZE	U.S. GAL	LITER	GPM/HZ	LPM/HZ
1 1/2	139.400	36.8296	0.4304	1.6291
2	90.790	23.9868	0.6609	2.5014
2 1/2	64.610	17.0700	0.9286	3.5149
3	41.050	10.8454	1.4616	5.5323
3 1/2	29.940	7.9102	2.0040	7.5852
4	22.660	5.9868	2.6478	10.022
5	13.700	3.6196	4.3796	16.577
6	9.1990	2.4304	6.5224	24.687
8	4.9060	1.2962	12.230	46.290
10	2.9450	0.7781	20.374	77.114
12	1.9930	0.5266	30.105	113.95

K-factors and A-factors are listed in U.S. gallons and in liters. Conversion formulas for other engineering units are listed below.

- K = 60/A**
- The K-factor is the number of pulses generated by the FP-6000 series paddlewheel per unit of liquid in a specific pipe size.
- A = 60/K**
- The A-factor is the flow rate (per minute) represented by 1 Hz output from the FP-6000 series sensor in a specific pipe size.

To convert K from

U.S. gallons
U.S. gallons
U.S. gallons
U.S. gallons
U.S. gallons
U.S. gallons
U.S. gallons

to

cubic feet
cubic inches
cubic meters
pounds of water
acre feet
liters
Imperial gallons

multiply K by

7.479
0.00433
263.85
0.120
325853
0.264
1.201

To convert K from

liters
liters
liters

to

cubic meters
kilograms of water
gallons

multiply K by

1000
1
3.785

Specifications

General Data

Flow velocity range:	1.6 to 20 ft/s 0.5 to 6 m/s
Linearity:	± 1% of full range
Repeatability:	±0.5% of full range
Pipe sizes:	
Standard version:	1.5 to 24 in. (38 to 610 mm)
Hot-Tap version:	1.5 to 36 in. (38 to 914 mm)
Cable length:	25 ft (7.6 m), can extend up to 200 ft (61 m) without amplification

Materials

Sensor material:	C36000 free cutting brass
Rotor material:	CD4MCu stainless steel
Rotor bearings:	Fluoroloy B®
Rotor shaft:	316 stainless steel (opt.) Tungsten Carbide (std.)
O-ring material:	Viton®

Electrical Data

Power requirements:	Self powered
Load impedance:	0 to 1000 Ω max.

Ambient Conditions

Maximum

Specifications

operating pressure: 225 psi (15 bar)

Maximum
operating temperature: 212°F (100 °C)



Caution: The FP-6002 and FP-6003 Series Hot-Tap system's overall specifications and limitations depend on the lowest maximum rating of the components associated with the system. For example, a ball valve, a component of the system, is rated at a maximum 100 psi @ 185°F, limiting the entire system's maximum pressure/temperature rating to 100 psi @ 185°F. All higher maximum specifications **MUST** yield to the component with the lowest maximum specification.



Note: Pressure/temperature specifications refer to sensor performance in water. Certain chemical limitations may apply. Chemical compatibility should be verified before sensor installation.



WARRANTY/DISCLAIMER

OMEGA ENGINEERING, INC. warrants this unit to be free of defects in materials and workmanship for a period of **13 months** from date of purchase. OMEGA's WARRANTY adds an additional one (1) month grace period to the normal **one (1) year product warranty** to cover handling and shipping time. This ensures that OMEGA's customers receive maximum coverage on each product.

If the unit malfunctions, it must be returned to the factory for evaluation. OMEGA's Customer Service Department will issue an Authorized Return (AR) number immediately upon phone or written request. Upon examination by OMEGA, if the unit is found to be defective, it will be repaired or replaced at no charge. OMEGA's WARRANTY does not apply to defects resulting from any action of the purchaser, including but not limited to mishandling, improper interfacing, operation outside of design limits, improper repair, or unauthorized modification. This WARRANTY is VOID if the unit shows evidence of having been tampered with or shows evidence of having been damaged as a result of excessive corrosion; or current, heat, moisture or vibration; improper specification; misapplication; misuse or other operating conditions outside of OMEGA's control. Components which wear are not warranted, including but not limited to contact points, fuses, and triacs.

OMEGA is pleased to offer suggestions on the use of its various products. However, OMEGA neither assumes responsibility for any omissions or errors nor assumes liability for any damages that result from the use of its products in accordance with information provided by OMEGA, either verbal or written. OMEGA warrants only that the parts manufactured by it will be as specified and free of defects. OMEGA MAKES NO OTHER WARRANTIES OR REPRESENTATIONS OF ANY KIND WHATSOEVER, EXPRESS OR IMPLIED, EXCEPT THAT OF TITLE, AND ALL IMPLIED WARRANTIES INCLUDING ANY WARRANTY OF MERCHANTABILITY AND FITNESS FOR A PARTICULAR PURPOSE ARE HEREBY DISCLAIMED. LIMITATION OF LIABILITY: The remedies of purchaser set forth herein are exclusive, and the total liability of OMEGA with respect to this order, whether based on contract, warranty, negligence, indemnification, strict liability or otherwise, shall not exceed the purchase price of the component upon which liability is based. In no event shall OMEGA be liable for consequential, incidental or special damages.

CONDITIONS: Equipment sold by OMEGA is not intended to be used, nor shall it be used: (1) as a "Basic Component" under 10 CFR 21 (NRC), used in or with any nuclear installation or activity; or (2) in medical applications or used on humans. Should any Product(s) be used in or with any nuclear installation or activity, medical application, used on humans, or misused in any way, OMEGA assumes no responsibility as set forth in our basic WARRANTY / DISCLAIMER language, and, additionally, purchaser will indemnify OMEGA and hold OMEGA harmless from any liability or damage whatsoever arising out of the use of the Product(s) in such a manner.

RETURN REQUESTS/INQUIRIES

Direct all warranty and repair requests/inquiries to the OMEGA Customer Service Department. BEFORE RETURNING ANY PRODUCT(S) TO OMEGA, PURCHASER MUST OBTAIN AN AUTHORIZED RETURN (AR) NUMBER FROM OMEGA'S CUSTOMER SERVICE DEPARTMENT (IN ORDER TO AVOID PROCESSING DELAYS). The assigned AR number should then be marked on the outside of the return package and on any correspondence.

The purchaser is responsible for shipping charges, freight, insurance and proper packaging to prevent breakage in transit.

FOR **WARRANTY** RETURNS, please have the following information available BEFORE contacting OMEGA:

1. Purchase Order number under which the product was PURCHASED,
2. Model and serial number of the product under warranty, and
3. Repair instructions and/or specific problems relative to the product.

FOR **NON-WARRANTY** REPAIRS, consult OMEGA for current repair charges. Have the following information available BEFORE contacting OMEGA:

1. Purchase Order number to cover the COST of the repair,
2. Model and serial number of the product, and
3. Repair instructions and/or specific problems relative to the product.

OMEGA's policy is to make running changes, not model changes, whenever an improvement is possible. This affords our customers the latest in technology and engineering.

OMEGA is a registered trademark of OMEGA ENGINEERING, INC.

© Copyright 2000 OMEGA ENGINEERING, INC. All rights reserved. This document may not be copied, photocopied, reproduced, translated, or reduced to any electronic medium or machine-readable form, in whole or in part, without the prior written consent of OMEGA ENGINEERING, INC.

Where Do I Find Everything I Need for Process Measurement and Control? OMEGA...Of Course!

Shop online at www.omega.com

TEMPERATURE

- Thermocouple, RTD & Thermistor Probes, Connectors, Panels & Assemblies
- Wire: Thermocouple, RTD & Thermistor
- Calibrators & Ice Point References
- Recorders, Controllers & Process Monitors
- Infrared Pyrometers

PRESSURE, STRAIN AND FORCE

- Transducers & Strain Gages
- Load Cells & Pressure Gages
- Displacement Transducers
- Instrumentation & Accessories

FLOW/LEVEL

- Rotameters, Gas Mass Flowmeters & Flow Computers
- Air Velocity Indicators
- Turbine/Paddlewheel Systems
- Totalizers & Batch Controllers

pH/CONDUCTIVITY

- pH Electrodes, Testers & Accessories
- Benchtop/Laboratory Meters
- Controllers, Calibrators, Simulators & Pumps
- Industrial pH & Conductivity Equipment

DATA ACQUISITION

- Data Acquisition & Engineering Software
- Communications-Based Acquisition Systems
- Plug-in Cards for Apple, IBM & Compatibles
- Datalogging Systems
- Recorders, Printers & Plotters

HEATERS

- Heating Cable
- Cartridge & Strip Heaters
- Immersion & Band Heaters
- Flexible Heaters
- Laboratory Heaters

ENVIRONMENTAL MONITORING AND CONTROL

- Metering & Control Instrumentation
- Refractometers
- Pumps & Tubing
- Air, Soil & Water Monitors
- Industrial Water & Wastewater Treatment
- pH, Conductivity & Dissolved Oxygen Instruments

Free Manuals Download Website

<http://myh66.com>

<http://usermanuals.us>

<http://www.somanuals.com>

<http://www.4manuals.cc>

<http://www.manual-lib.com>

<http://www.404manual.com>

<http://www.luxmanual.com>

<http://aubethermostatmanual.com>

Golf course search by state

<http://golfingnear.com>

Email search by domain

<http://emailbydomain.com>

Auto manuals search

<http://auto.somanuals.com>

TV manuals search

<http://tv.somanuals.com>