

1 YEAR
WARRANTY

MADE IN
USA



User's Guide

Shop online at

omega.com[®]

Ω OMEGA

omega.com

e-mail: info@omega.com

For latest product manuals:

omegamanual.info

TX91 Thermocouple Two-Wire Temperature Transmitter

Download from [Www.Somanuals.com](http://www.Somanuals.com). All Manuals Search And Download.



OMEGAnet® On-Line Service
omega.com

Internet e-mail
info@omega.com

**Servicing
North America:**

U.S.A.:

ISO 9001 Certified

One Omega Drive, Box 4047

Stamford, CT 06907-0047

Tel: (203) 359-1660

FAX: (203) 359-7700

e-mail: info@omega.com

Canada:

976 Bergar

Laval (Quebec) H7L 5A1, Canada

Tel: (514) 856-6928

FAX: (514) 856-6886

e-mail: info@omega.ca

**For immediate technical or
application assistance:**

U.S.A. and Canada:

Sales Service: 1-800-826-6342/1-800-TC-OMEGA®

Customer Service: 1-800-622-2378/1-800-622-BEST®

Engineering Service: 1-800-872-9436/1-800-USA-WHEN®

Mexico:

En Español: (001) 203-359-7803

FAX: (001) 203-359-7807

e-mail: espanol@omega.com

info@omega.com.mx

Servicing Europe:

Czech Republic:

Frvstavska 184, 733 01 Karviná, Czech Republic
Tel:+420(0)59 6311899 FAX:+420(0)59 6311114
Toll Free: 0800-1-66342
e-mail: info@omegashop.cz

Germany/Austria:

Daimlerstrasse 26, D-75392
Deckenpfronn, Germany
Tel: 49 (0)7056 9398-0 FAX: 49 (0)7056 9398-29
Toll Free in Germany: 0800 82 66342
e-mail: info@omega.de

United Kingdom: ISO 9002 Certified

One Omega Drive
River Bend Technology Centre
Northbank, Irlam, Manchester
M44 5BD, United Kingdom
Tel: +44 (0)161 777-6611
FAX: +44 (0)161 777-6622
Toll Free in United Kingdom: 0800-488-488
e-mail: info@omega.co.uk

It is the policy of OMEGA Engineering, Inc. to comply with all worldwide safety and EMC/EMI regulations that apply. OMEGA is constantly pursuing certification of its products to the European New Approach Directives. OMEGA will add the CE mark to every appropriate device upon certification. The information contained in this document is believed to be correct, but OMEGA accepts no liability for any errors it contains, and reserves the right to alter specifications without notice.

WARNING: These products are not designed for use in, and should not be used for, human applications.

RETURN REQUESTS / INQUIRIES

Direct all warranty and repair requests/inquiries to the OMEGA Customer Service Department. BEFORE RETURNING ANY PRODUCT(S) TO OMEGA, PURCHASER MUST OBTAIN AN AUTHORIZED RETURN (AR) NUMBER FROM OMEGA'S CUSTOMER SERVICE DEPARTMENT (IN ORDER TO AVOID PROCESSING DELAYS). The assigned AR number should then be marked on the outside of the return package and on any correspondence. The purchaser is responsible for shipping charges, freight, insurance and proper packaging to prevent breakage in transit.

FOR **WARRANTY** RETURNS, please have the following information available BEFORE contacting OMEGA:

1. Purchase Order number under which the product was PURCHASED,
2. Model and serial number of the product under warranty, and
3. Repair instructions and/or specific problems relative to the product.

FOR **NON-WARRANTY** REPAIRS, consult OMEGA for current repair charges. Have the following information available BEFORE contacting OMEGA:

1. Purchase Order number to cover the COST of the repair,
2. Model and serial number of the product, and
3. Repair instructions and/or specific problems relative to the product.

OMEGA's policy is to make running changes, not model changes, whenever an improvement is possible. This affords our customers the latest in technology and engineering. OMEGA is a registered trademark of OMEGA ENGINEERING, INC.

© Copyright 2005 OMEGA ENGINEERING, INC. All rights reserved. This document may not be copied, photocopied, reproduced, translated, or reduced to any electronic medium or machine-readable form, in whole or in part, without the prior written consent of OMEGA ENGINEERING, INC.

TX91

Miniature Two-Wire Thermocouple Transmitter

	Page
Section 1 Introduction	1
1.1 General Description	1
1.2 Features	8
1.3 Models Available	8
Section 2 Unpacking Instructions	9
Section 3 Installation	11
3.1 Mounting the TX91	10
3.2 Wiring the TX91	16

	Page
Section 4 Calibration Instructions	18
4.1 Equipment Required	18
4.2 Set-up of Equipment	19
4.3 Calibration Procedures	20
Section 5 Troubleshooting Guide	25
Section 6 Accessories	26
Section 7 Specifications	27
Appendix A	
Intrinsically Safe Interconnection Diagram	30

1.1 General Description

The OMEGA® TX90 Series Temperature Transmitters consist of the TX91 Miniature Two-Wire Thermocouple Transmitter and the TX92 Miniature Two-Wire RTD Transmitter. This manual is written for the OMEGA TX91 Thermocouple Transmitter.

The TX91 Transmitter accepts thermocouple sensor types J, K, T, or E and will produce a standard 4-20 mA output signal proportional to that produced by its attached input temperature sensor. Transmission of the proportional current output may be accomplished by using copper wires.

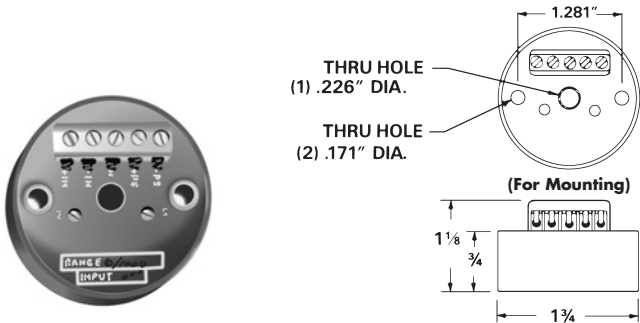

Figure 1-1. Photo of TX90 Series Transmitter

Figure 1-2. General Dimensions (in inches)

The TX91 transmitter is normally powered by an unregulated DC power supply as shown in Figure 1-3. The proportionally-transmitted signal begins at 4 mA, at the low end of its temperature range, and increases to 20 mA, at the high end of its temperature range. (There are various temperature ranges and thermocouple types available for the TX91. To order, refer to Section 1.3 for correct Model Numbers and Range Codes.)

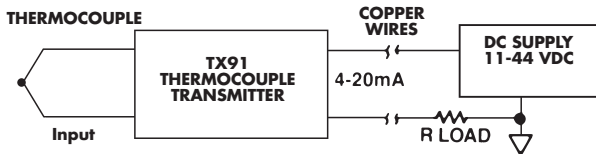

Figure 1-3. TX91 Thermocouple Transmitter

The TX91 two-wire transmitter receives and measures signals from thermocouples and sends an output current of 4-20 mA which is directly proportional to the thermocouple millivolt input. It is designed to connect with only two copper wire leads that will supply the voltage to operate the transmitter from a DC power supply, and also carry the output current. The output current is then used for recording, computing or controlling.

If the TX91 is mounted inside a protection head, such as the OMEGA NB1 Protection Head (see Figure 3-1), the thermocouple extension wires are replaced by two copper wires that carry the 4-20 mA signal and DC voltage to operate the transmitter. (Refer to the OMEGA Temperature Handbook for information on NB1 Thermocouple Assembly.)

The TX91 has reverse supply polarity protection and will operate with a wide range of supply voltages (11 to 44VDC). It has an input sensor break-protection circuit that forces the output current to go upscale when the thermocouple wire opens. It also is provided with a screw terminal, where the output current can be measured without interrupting the power loop. The TX91 does NOT provide isolation between its input and the 4-20 mA output; therefore, an undergrounded thermocouple junction is suggested to prevent possible ground loops.

Note that most thermocouple transmitters with 4-20 mA outputs, including the TX91, are proportional with respect to the thermocouple input voltage. However, the relationship between temperature and millivolt for all the thermocouple types is somewhat non-linear. This leads to maximum error at approximately the midpoint of the range as shown in Figure 1-4.

5

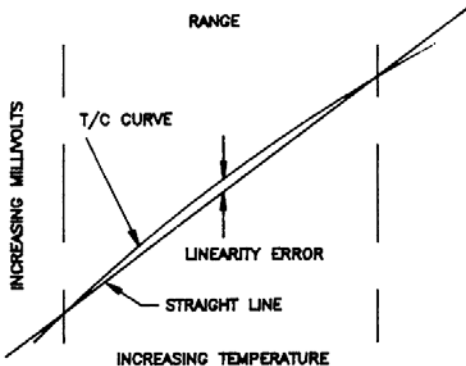

Figure 1-4. Straight line Approximation of Curve
Download from [Www.Somanuals.com](http://www.Somanuals.com). All Manuals Search And Download.

1.2 Features

- 4-20 mA output
- $\pm 0.1\%$ full-scale accuracy (with respect to the mV input signal)
- Upscale break protection
- Low cost

1.3 Models Available

Table 1-1. Range Code

Range	Input Types			
	J	K	T	E
0 to 200°F	J2	K2	T2	E2
0 to 300°F	J3	K3	T3	E3
0 to 500°F	J4	K4	T4	E4
0 to 750°F	J5	K5		E5
0 to 1000°F	J6	K6		E6

TX91 Models Available

Model Number	Description
TX91-(*)	Thermocouple transmitter (J, K, T, or E)
NB1TX-(*)	NB1 thermocouple probe, 12" L, 1/4" O.D., ungrounded junction, 304SS sheath, TX91 Transmitter

**Insert range code from Table 1-1*

For complete information on NB1 Thermocouple Probes, see the OMEGA Temperature Handbook.

2

Unpacking

Remove the packing list and verify that all equipment has been received. If there are any questions about the shipment, please call the OMEGA Customer Service Department at 1-800-622-2378 or (203) 359-1660.

Upon receipt of shipment, inspect the container and equipment for signs of damage. Take particular note of any evidence of rough handling in transit. Immediately report any damage to the shipping agent.

NOTE

The carrier will not honor any claims unless all shipping material is saved for their examination. After examining and removing contents, save packing material in event reshipment is necessary.

3

Installation

3.1 Mounting the TX91

The TX91 Transmitter may be:

1. surface mounted,
2. mounted inside a protection head (refer to figure 3-1), or
3. installed into the OMEGA mounting track (part number RT) using an OMEGA mounting bracket (part number TX90-BR).

Figure 3-2 shows the RT mounting track.

Figure 3-3 shows the TX90-BR mounting bracket.

Figure 3-4 shows a typical installation of two transmitters using the mounting bracket and mounting track.

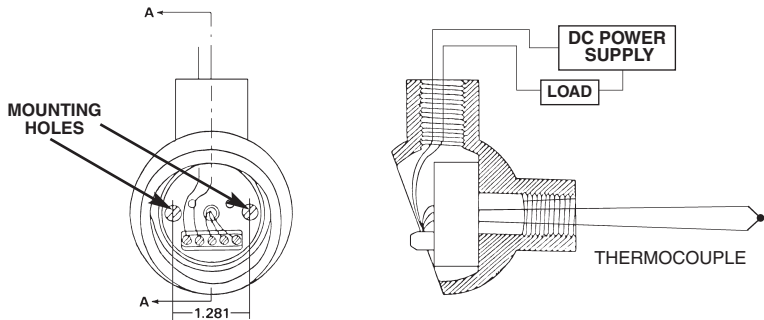
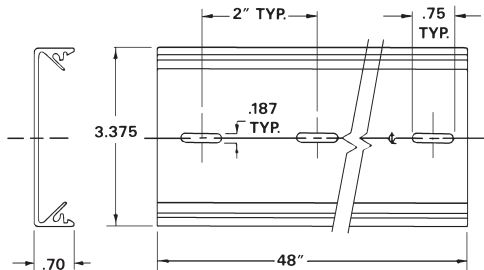

Figure 3-1 Assembly of the TX91 Transmitter Inside an OMEGA NB1 Protection Head (in inches)



CAUTION
HANDTIGHTEN
TRANSMITTER
MOUNTING
SCREWS ONLY.
DO NOT OVER-
TIGHTEN.

Figure 3-2 RT Mounting Track (in inches)

3

Installation

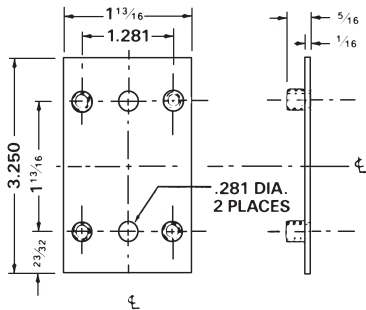

13

Figure 3-3 TX90-BR Mounting Bracket (in inches)Download from Www.Somanuals.com. All Manuals Search And Download.

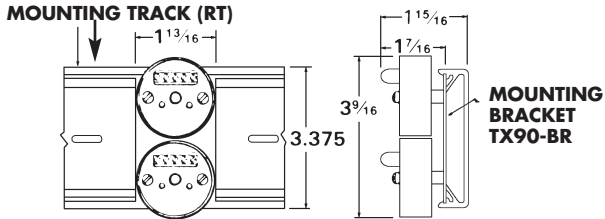

**Figure 3-4 Installation with Bracket and Track (in inches)
TX90-BR & RT**

3.2 Wiring the TX91 (Refer to Figure 3-5)

1. Connect a DC power supply in series with the load to the (+PS) and (-PS) power terminals. Note that the load (usually a monitoring instrument) may be connected to either the (+) or (-) power lead.
2. Connect the thermocouple to the (+IN) and (-IN) input terminals.

NOTE

A milliamp monitoring instrument can be used in the circuit by connecting the monitor's positive lead to (+PS) and the negative lead to (M). This allows monitoring the current loop without disconnecting the main wiring.

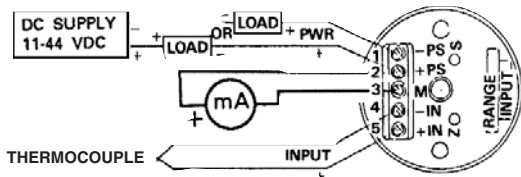

Figure 3-5 Wiring Diagram for the TX91 Potentiometers

4

Calibration Instructions

4.1 Equipment Required

- Precision mV source, with 0.001 mV resolution and $\pm 0.002\text{mV}$ accuracy or
 - Precision DVM with $\pm 0.002\text{mV}$ accuracy and adjustable mV source with 0.001mV resolution
 - OMEGA TRC III Ice Point Reference (or stable ice bath)
- Temperature Reference Probe (OMEGA P/N: TRP-(*))
**Thermocouple Type: J, K, T, E*
 - Or a Thermocouple Calibrator/Simulator

17

4.2 Set-up of Equipment

To prepare the ice bath:

- a) Fill a glass beaker with crushed ice made from distilled water.
- b) Fill the beaker with enough distilled water so that ice just becomes slush, but not enough to float the ice.
- c) Insert the reference thermocouple.

Figure 4-2 shows an alternate set-up. Here, a high precision thermocouple calibrator, such the OMEGA Model CL511, replaces the DVM, ice bath, voltage source, etc.

4.3 Calibration Procedures (Refer to Figure 4-1)

Connect the calibration equipment according to Figure 4-1 or 4-2. The thermocouple wire (J, K, T, E) must be of the same calibration as the transmitter being calibrated. Make sure that the wiring polarities are correct. (Note that the RED thermocouple wire is NEGATIVE.)

To check or adjust the calibration:

1. Locate the Z (zero) and S (span) potentiometers.
2. Select, from Table 4-1, the correct mV values for the Z (zero) and S (span) adjustments that correspond to the Model Number. For example, for Model TX91-J2, the Z input is -0.885 mV, and the S input is 4.906 mV.

If a Thermocouple Calibrator/Simulator is used, such as the OMEGA Model CL511 Precision Calibrator, select the Temperature Input Z (zero) and S (span) values.

3. Set the DC mV source to the selected Z (zero) mV value. Adjust the Z potentiometer to read 4.000 mA on the monitoring instrument.
4. Set the DC mV source to the selected S (span) mV value. Adjust the S potentiometer to read 20.000 mA on the monitoring instrument.
5. Repeat steps 3 and 4, as required, until the readings are exactly 4.000 mA and 20.000 mA. This procedure is necessary since there is interaction between the two potentiometers.

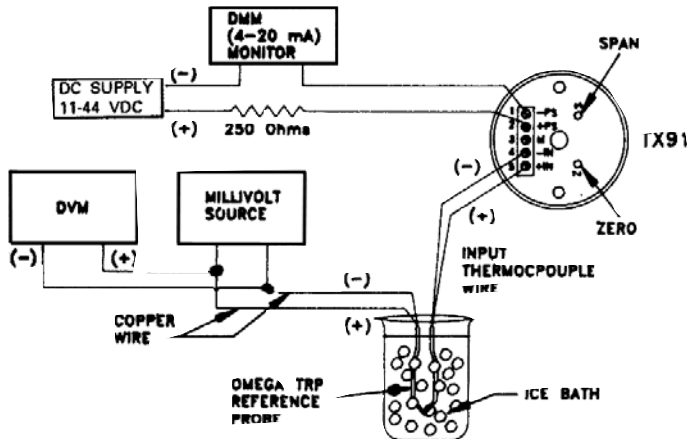

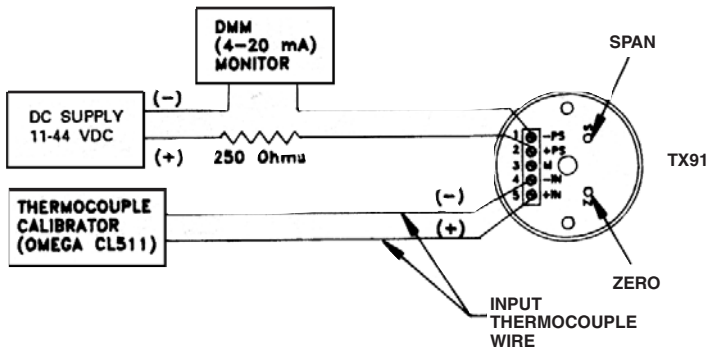

Figure 4-2. Calibration Set-Up. (Alternate)

Download from [Www.Somanuals.com](http://www.Somanuals.com). All Manuals Search And Download.

Table 4-1. Calibration Values for the TX92

Temperature Input Range Zero/Span	Model TX92	mV INPUT REF 32°F Zero/Span	Model TX92	mV INPUT REF 32°F Zero/Span
0/ 200°F	-J2	-0.855/ 4.906	-K2	-0.692/ 3.819
0/ 300°F	-J3	-0.885/ 7.947	-K3	-0.692/ 6.092
0/ 500°F	-J4	-0.885/14.108	-K4	-0.692/10.560
0/ 750°F	-J5	-0.885/20.406	-K5	-0.692/15.295
0/1000°F	-J6	-0.885/29.515	-K6	-0.692/22.251
0/ 200°F	-T2	-0.674/ 3.967	-E2	-1.026/ 5.869
0/ 300°F	-T3	-0.674/ 6.647	-E3	-1.026/ 9.708
0/ 500°F	-T4	-0.674/12.572	-E4	-1.026/17.942
0/ 750°F	--	--	-E5	-1.026/26.858
0/1000°F	--	--	-E6	-1.026/40.056

Malfunction or incorrect operation may be caused by:

1. Reversed polarity:

Check the wiring using Figure 3-5 as a guide. If the temperature of the thermocouple increases while the current magnitude decreases, the problem could be caused by reversed polarity of the:

- a) thermocouple wiring
- b) power supply leads
- c) monitor instrument

2. Loose or broken wires:

Check each terminal connection for tightness. Move each wire back and forth and note any changes in operation.

3. Too high a load resistance in the output current loop or too low a current rating on the power supply:

- a) Measure the total resistance of each device (excluding the transmitter and power supply) in the 20 mA loop, including the resistance of the lead wires.
- b) Calculate the maximum allowable loop resistance using the formula:

$$\text{Loop Resistance (maximum)} = \frac{V_{\text{supply}} - 11\text{V}}{0.020\text{A}}$$

For example, a 24V power supply would give a maximum loop resistance of: $13\text{V}/0.020\text{A} = 650$ ohms.

- c) Make sure the power supply is rated for at least 28 mA times the number of TX91 transmitters being powered. For example, if the supply is powering 5 transmitters, the supply should be rated for at least 140 mA.

6**Accessories**

Model No.	Description
TX90-BR	Mounting Bracket
PSU-24B	Unregulated Power Supply, 24 Volts
TX82A	Process Loop-Powered Indicator
RT	48" Mounting Track

General

SIZE:	1.75" dia. X 1.125" high (includes terminal strip)
ZERO/SPAN ADJUSTMENT RANGE:	±25%
POWER SUPPLY VOLTAGE OPERATING RANGE:	+11VDC to +44VDC, 28 mA max required per transmitter
ACCURACY:	±0.1% of full scale (includes effects of hysteresis, repeatability and linearity proportional to the T/C)
AMBIENT TEMPERATURE:	-13°F to 185°F (-25°C to 85°C)
STORAGE TEMPERATURE RANGE:	-85°F to 193°F (-65°C to 89°C)

THERMAL ZERO SHIFT:	<0.01%/°F of span (span >5 mV) <0.02%/°F of span (2-5 mV span)
THERMAL SPAN SHIFT:	<0.01%/°F of span
WEIGHT:	1.5 oz (50g)

Output

CURRENT OUTPUT SPAN:	4-20 mA DC
CURRENT OUTPUT LIMITS:	3 to 28 mA, typical
MAXIMUM LOOP RESISTANCE:	$(V_{\text{supply}} - 11V)/0.020A = \text{ohms}$
LOAD RESISTANCE EFFECT:	0.05% of span per 300 ohms change
POWER SUPPLY EFFECT:	0.01% of output span per volt

Input

SENSOR:	Thermocouple
INPUT BREAK PROTECTION:	Upscale

Intrinsically Safe Interconnection Diagram

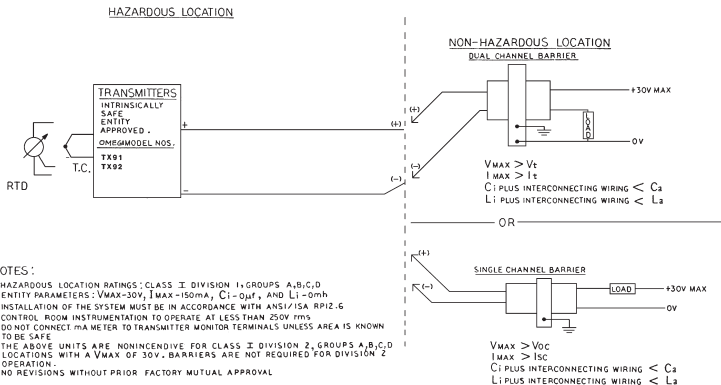



WARRANTY/DISCLAIMER

OMEGA ENGINEERING, INC. warrants this unit to be free of defects in materials and workmanship for a period of **13 months** from date of purchase. The OMEGA® WARRANTY adds an additional one (1) month grace period to the normal **one (1) year product warranty** to cover handling and shipping time. This ensures that OMEGA's customers receive maximum coverage on each product.

If the unit malfunctions, it must be returned to the factory for evaluation. OMEGA's Customer Service Department will issue an Authorized Return (AR) number immediately upon phone or written request. Upon examination by OMEGA, if the unit is found to be defective, it will be repaired or replaced at no charge. OMEGA's WARRANTY does not apply to defects resulting from any action of the purchaser, including but not limited to mishandling, improper interfacing, operation outside of design limits, improper repair, or unauthorized modification. This WARRANTY is VOID if the unit shows evidence of having been tampered with or shows evidence of having been damaged as a result of excessive corrosion; or current, heat, moisture or vibration; improper specification; misapplication; or misuse or other operating conditions outside of OMEGA's control. Components in which wear is not warranted, include but are not limited to contact points, fuses, and triacs.

OMEGA is pleased to offer suggestions on the use of its various products. However, OMEGA neither assumes responsibility for any omissions or errors nor assumes liability for any damages that result from the use of its products in accordance with information provided by OMEGA, either verbal or written. OMEGA warrants only that the parts manufactured by the company will be as specified and free of defects. OMEGA MAKES NO OTHER WARRANTIES OR REPRESENTATIONS OF ANY KIND WHATSOEVER, EXPRESSED OR IMPLIED, EXCEPT THAT OF TITLE, AND ALL IMPLIED WARRANTIES INCLUDING ANY WARRANTY OF MERCHANTABILITY AND FITNESS FOR A PARTICULAR PURPOSE ARE HEREBY DISCLAIMED. LIMITATION OF LIABILITY: The remedies of purchaser set forth herein are exclusive, and the total liability of OMEGA with respect to this order, whether based on contract, warranty, negligence, indemnification, strict liability or otherwise, shall not exceed the purchase price of the component upon which liability is based. In no event shall OMEGA be liable for consequential, incidental or special damages.

CONDITIONS: Equipment sold by OMEGA is not intended to be used, nor shall it be used: (1) as a "Basic Component" under 10 CFR 21 (NRC), used in or with any nuclear installation or activity; or (2) in medical applications or used on humans. Should any Product(s) be used in or with any nuclear installation or activity, medical application, used on humans, or misused in any way, OMEGA assumes no responsibility as set forth in our basic WARRANTY/ DISCLAIMER language, and, additionally, purchaser will indemnify OMEGA and hold OMEGA harmless from any liability or damage whatsoever arising out of the use of the Product(s) in such a manner.

Where Do I Find Everything I Need for Process Measurement and Control? OMEGA...Of Course!

Shop online at omega.com

TEMPERATURE

- Thermocouple, RTD & Thermistor Probes, Connectors, Panels & Assemblies
- Wire: Thermocouple, RTD & Thermistor
- Calibrators & Ice Point References
- Recorders, Controllers & Process Monitors
- Infrared Pyrometers

PRESSURE, STRAIN AND FORCE

- Transducers & Strain Gages
- Load Cells & Pressure Gages
- Displacement Transducers
- Instrumentation & Accessories

FLOW/LEVEL

- Rotameters, Gas Mass Flowmeters & Flow Computers
- Air Velocity Indicators
- Turbine/Paddlewheel Systems
- Totalizers & Batch Controllers

pH/CONDUCTIVITY

- pH Electrodes, Testers & Accessories
- Benchtop/Laboratory Meters
- Controllers, Calibrators, Simulators & Pumps
- Industrial pH & Conductivity Equipment

DATA ACQUISITION

- Data Acquisition & Engineering Software
- Communications-Based Acquisition Systems
- Plug-in Cards for Apple, IBM & Compatibles
- Datalogging Systems
- Recorders, Printers & Plotters

HEATERS

- Heating Cable
- Cartridge & Strip Heaters
- Immersion & Band Heaters
- Flexible Heaters
- Laboratory Heaters

ENVIRONMENTAL MONITORING AND CONTROL

- Metering & Control Instrumentation
- Refractometers
- Pumps & Tubing
- Air, Soil & Water Monitors
- Industrial Water & Wastewater Treatment
- pH, Conductivity & Dissolved Oxygen Instruments

Free Manuals Download Website

<http://myh66.com>

<http://usermanuals.us>

<http://www.somanuals.com>

<http://www.4manuals.cc>

<http://www.manual-lib.com>

<http://www.404manual.com>

<http://www.luxmanual.com>

<http://aubethermostatmanual.com>

Golf course search by state

<http://golfingnear.com>

Email search by domain

<http://emailbydomain.com>

Auto manuals search

<http://auto.somanuals.com>

TV manuals search

<http://tv.somanuals.com>