

2 YEAR
WARRANTY

MADE IN
USA



User's Guide

Shop online at

omega.com[®]

Ω OMEGA[®]

omega.com

e-mail: info@omega.com

*For latest product manuals:
omegamanual.info*

ISO 9001
CERTIFIED
CORPORATE QUALITY

STAMFORD, CT

ISO 9002
CERTIFIED
CORPORATE QUALITY

MANCHESTER, UK

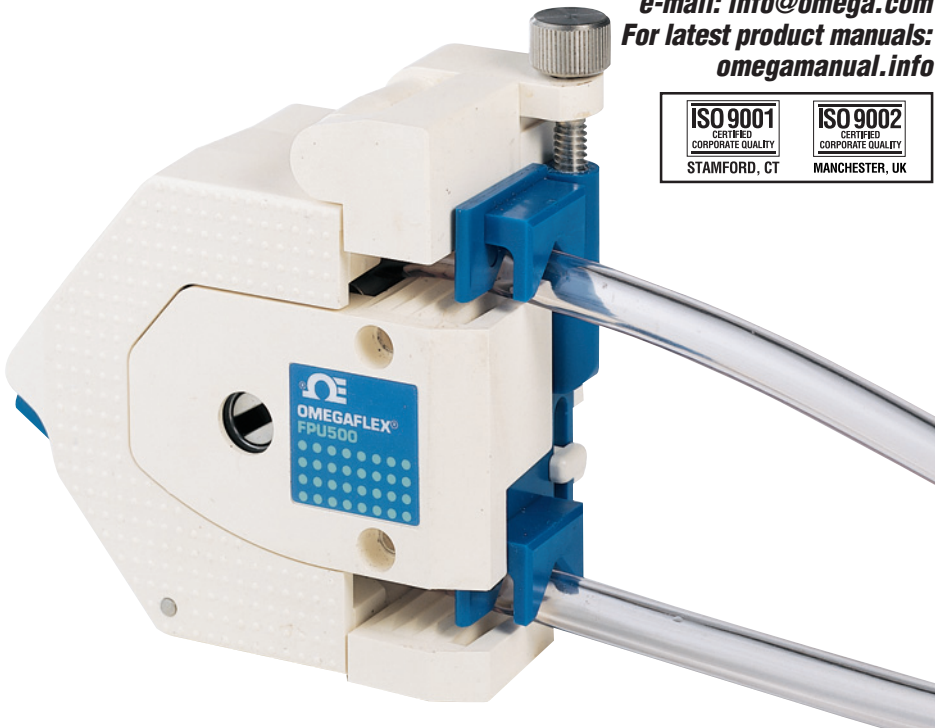

FPU500 **OMEGAFLEX[®] Peristaltic Pump**

Download from www.Somanuals.com. All Manuals Search And Download.



OMEGAnet® Online Service omega.com	Internet e-mail info@omega.com
---	---

Servicing North America:

U.S.A.: One Omega Drive, Box 4047
ISO 9001 Certified Stamford, CT 06907-0047
Tel: (203) 359-1660 FAX: (203) 359-7700
e-mail: info@omega.com

Canada: 976 Bergar
Laval (Quebec) H7L 5A1, Canada
Tel: (514) 856-6928 FAX: (514) 856-6886
e-mail: info@omega.ca

For immediate technical or application assistance:

U.S.A. and Canada: Sales Service: 1-800-826-6342 / 1-800-TC-OMEGA®
Customer Service: 1-800-622-2378 / 1-800-622-BEST®
Engineering Service: 1-800-872-9436 / 1-800-USA-WHEN®

Mexico: En Español: (001) 203-359-7803 e-mail: espanol@omega.com
FAX: (001) 203-359-7807 info@omega.com.mx

Servicing Europe:

Benelux: Postbus 8034, 1180 LA Amstelveen, The Netherlands
Tel: +31 (0)20 3472121 FAX: +31 (0)20 6434643
Toll Free in Benelux: 0800 0993344
e-mail: sales@omegaeng.nl

Czech Republic: Frystatska 184, 733 01 Karviná, Czech Republic
Tel: +420 (0)59 6311899 FAX: +420 (0)59 6311114
Toll Free: 0800-1-66342 e-mail: info@omegashop.cz

France: 11, rue Jacques Cartier, 78280 Guyancourt, France
Tel: +33 (0)1 61 37 2900 FAX: +33 (0)1 30 57 5427
Toll Free in France: 0800 466 342
e-mail: sales@omega.fr

Germany/Austria: Daimlerstrasse 26, D-75392 Deckenpfronn, Germany
Tel: +49 (0)7056 9398-0 FAX: +49 (0)7056 9398-29
Toll Free in Germany: 0800 639 7678
e-mail: info@omega.de

United Kingdom: One Omega Drive, River Bend Technology Centre
ISO 9002 Certified Northbank, Irlam, Manchester
M44 5BD United Kingdom
Tel: +44 (0)161 777 6611 FAX: +44 (0)161 777 6622
Toll Free in United Kingdom: 0800-488-488
e-mail: sales@omega.co.uk

It is the policy of OMEGA Engineering, Inc. to comply with all worldwide safety and EMC/EMI regulations that apply. OMEGA is constantly pursuing certification of its products to the European New Approach Directives. OMEGA will add the CE mark to every appropriate device upon certification.

The information contained in this document is believed to be correct, but OMEGA accepts no liability for any errors it contains, and reserves the right to alter specifications without notice.

WARNING: These products are not designed for use in, and should not be used for, human applications.



Remove the Packing List and verify that you have received all equipment, including the following (quantities in parentheses):

Peristaltic Pump (1)

Mounting Screws * (2)

Operator's Manual (1)

*Long Mounting Screws (2) Optional

If you have any questions about the shipment, please call the Customer Service Department.

When you receive the shipment, inspect the container and equipment for signs of damage. Note any evidence of rough handling in transit. Immediately report any damage to the shipping agent.

NOTE

The carrier will not honor damage claims unless all shipping material is saved for inspection. After examining and removing contents, save packing material and carton in the event reshipment is necessary.

From the Technical Library of _____

	Page
Unpacking Instructions	i
Chapter 1 Introduction	1-1
1.1 Description	1-1
1.2 Features	1-1
Chapter 2 Parts of the Pump	2-1
2.1 Overall View of the Pump	2-1
2.2 Left Side of the Pump	2-2
2.3 Right Side of the Pump	2-3
Chapter 3 Setting Up the Pump(s)	3-1
3.1 Introduction	3-1
3.2 Required Hardware	3-1
3.3 Attaching the Pump	3-2
3.3.1 Attaching a Single Pump Directly to the Motor	3-2
3.3.2 Stacking Two Pumps onto One Motor	3-4
3.3.3 Attaching a Single Pump to an Adapter Plate	3-6
3.3.4 Using Your Own Adapter Plate	3-8
Chapter 4 Tubing Information	4-1
4.1 Selecting Tubing	4-1
4.2 Tubing Life	4-1
Chapter 5 Operating the Pump	5-1
5.1 Introduction	5-1
5.2 Loading the Tubing	5-2
5.3 Operating the Pump	5-4
5.4 Adjusting the Clamp Screw	5-5
Chapter 6 Maintenance	6-1
6.1 Introduction	6-1
6.2 Replacing the Rotor Assembly	6-2
Chapter 7 Troubleshooting Guide	7-1
Chapter 8 Technical Details	8-1
8.1 Theory of Operation	8-1
8.2 Design Considerations	8-1
8.3 Design Solution	8-1
8.4 Stacking More than Two Pumps	8-2
Chapter 9 Specifications	9-1
Chapter 10 Spare Parts and Accessories	10-1
Index	I

A

Adapter Plate	3-6
Adapter Plate Specifications	3-8

C

Clamp Screw Adjustment	5-5
Creeping of Tubing	5-5

F

Flow Rates	1-1
------------------	-----

M

Mounting Screw Types	3-1
----------------------------	-----

P

Pump	
Attaching ...	
One pump to the Motor	3-2
One pump to an Adapter Plate	3-6
(Stacking) More than Two Pumps	8-2
Two Pumps to the Motor	3-4
Left Side View	2-2
Maintaining.....	6-1
Operating	3-1
Overall View	2-1
Right Side View	2-3

R

Rotor Assembly - Replacing	6-2
----------------------------------	-----

S

Screw Types	3-1
Stacking Two Pumps	3-4

T

Tubing, Creeping of	5-5
Tubing, Life of	4-1, 9-4
Tubing, Loading	5-2
Tubing Materials	4-1

1.1 Description

The peristaltic pump offers exceptional simplicity, ease-of-use, and variable flow capacity. The pump is self-priming and non-siphoning. It prevents back flow since one of the three rollers is always compressing the tubing. As one section of a tube fatigues, simply move the tube along to an unused section and continue pumping. To facilitate changing the tubing, a latch mechanism allows for easy opening and closing of the pump.

No tools are required to load the tube. Pumps are mounted to a pump motor via two screws and can be double stacked. Tubing can even be changed on stacked pumps without detaching either of the pumps from the motor. Once tubing is loaded, a clamp plate holds it securely in place during pump operation. A single pump can handle a broad range of flow rates and tube materials.

1.2 Features

- ✔ Stainless steel rotor assembly
- ✔ Ideal for use in sterile, corrosive, or general laboratory operating environments.
- ✔ Flow rates from 0.5 to 2280 mL/minute (36 gallons/hour)
- ✔ Quick mounting to pump motor
- ✔ Easily stackable mounting for multi-channel pumping
- ✔ Three-roller geometry reduces pulsation and improves priming
- ✔ Polysulfone housing for durability and chemical resistance

Notes

2.1 Overall View of the Pump

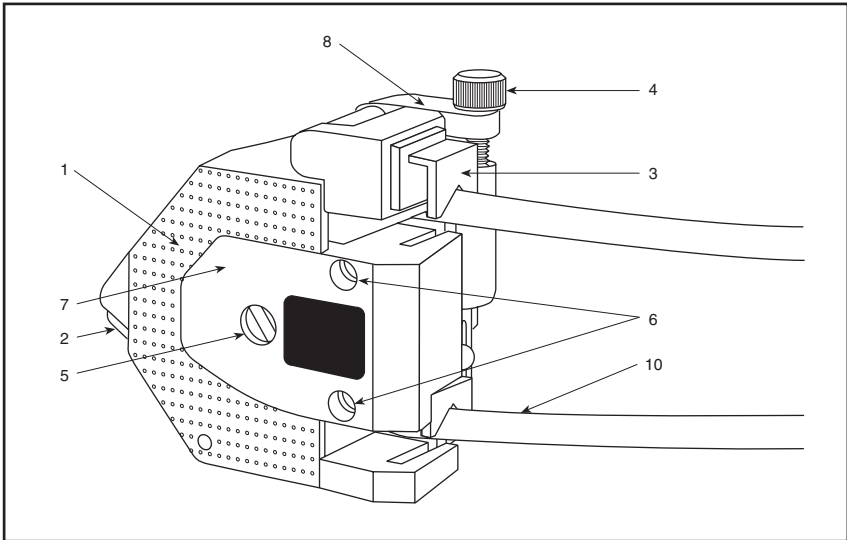

Figure 2-1. Overall View

Item	Description	Function
1	Stator	Fixed surface for tubing compression
2	Latch	Used to open and close the Stator
3	Clamp Plate	Secures the tubing during pump operation
4	Clamp Screw	Adjusts the tubing clamp position
5	Rotor Shaft	Main drive shaft for the pump
6	Mounting Holes	Allow clearance for Mounting Screws
7	Lower Shield	Shields the tubing, supports the Rotor Assembly
8	Base	Mounting surface to attach the pump to the motor, supports the Rotor Assembly
9	Mounting Screws	Attach the pump to the motor (screws not shown)
10	Tubing	Conduit for fluid

2.2 Left Side of the Pump

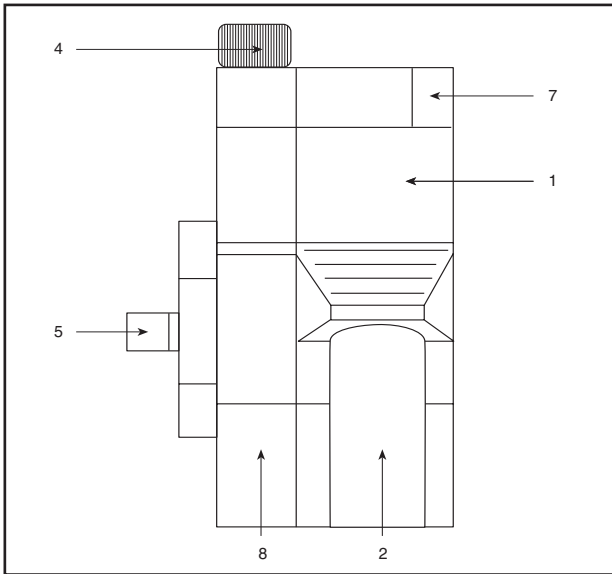

Figure 2-2. View of the Left Side

Item	Description	Function
1	Stator	Fixed surface for tubing compression
2	Latch	Used to open and close the stator
4	Clamp Screw	Adjusts the tubing clamp position
5	Rotor Shaft	Main drive shaft for the pump
7	Lower Shield	Shields the tubing, supports the Rotor Assembly
8	Base	Mounting surface to attach the pump to the motor, supports the Rotor Assembly

2.3 Right Side of the Pump

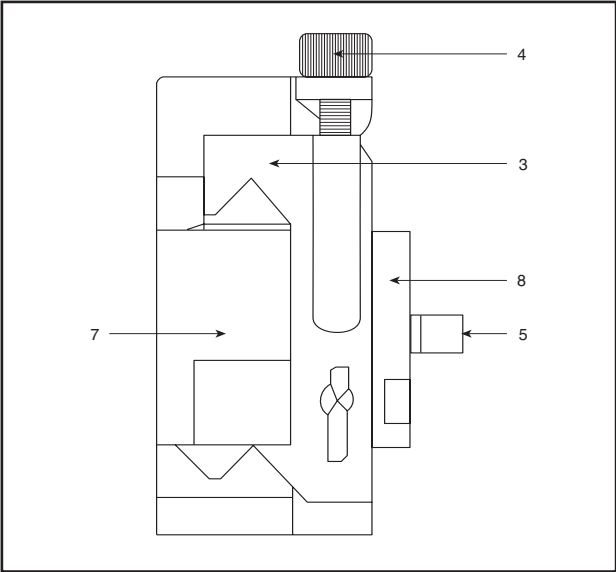

Figure 2-3. View of the Right Side

Item	Description	Function
3	Clamp Plate	Secures the tubing during pump operation
4	Clamp Screw	Adjusts the tubing clamp position
5	Rotor Shaft	Main drive shaft for the pump
7	Lower Shield	Shields the tubing, supports the Rotor Assembly
8	Base	Mounting surface to attach the pump to the motor, supports the Rotor Assembly

3.1 Introduction

To attach a single pump directly to a pump motor, follow the procedure in Section 3.3.1.

To stack two pumps to a motor, follow the procedure in Section 3.3.2.

To attach the pump to an adapter plate (for your own motor), follow the procedure in Section 3.3.3.

To use your own adapter plate, follow the procedure in Section 3.3.4.

NOTE

Before you mount the pump to any pump motor, make sure that power to the motor is turned off.

3.2 Required Hardware

Number of Pumps Stacked	Mounting Screw Type	Mounting Screw Part Number	Number of Mounting Screws	Adapter Plate* Assembly Number
1	Standard	FPU500-SMS**	2	FPU500-AP
2	Long	FPU500-LMS [†]	2	FPU500-AP

* Optional adapter plate assembly includes mounting screws and pins

** Supplied standard with pump; can only be used to mount a single pump

[†] Must be specified at the time of ordering the pump; can only be used for mounting 2 stacked pumps

3.3 Attaching the Pump

3.3.1 Attaching a Single Pump Directly to the Motor

Refer to Figures 3-1 through 3-4 and Figure A.

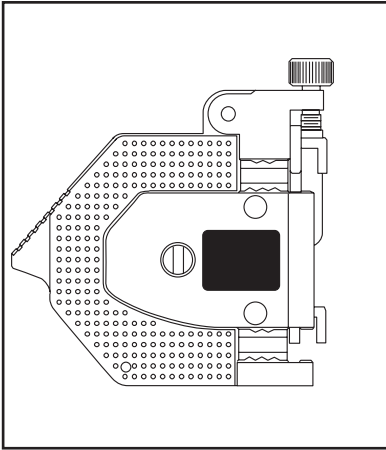

Figure 3-1. Pump in Closed Position

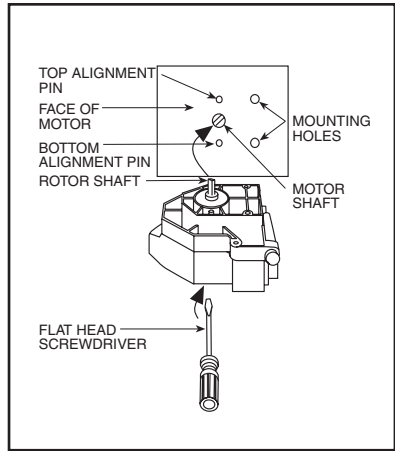

Figure 3-2. Aligning the Rotor Shaft

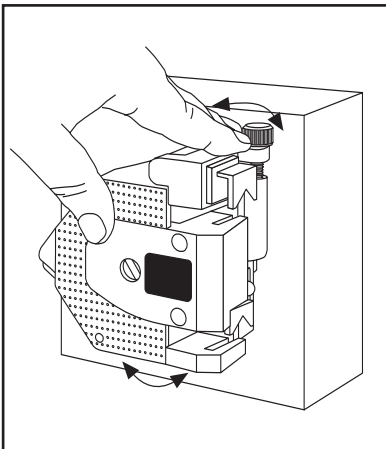

Figure 3-3. Aligning the Pins and Holes

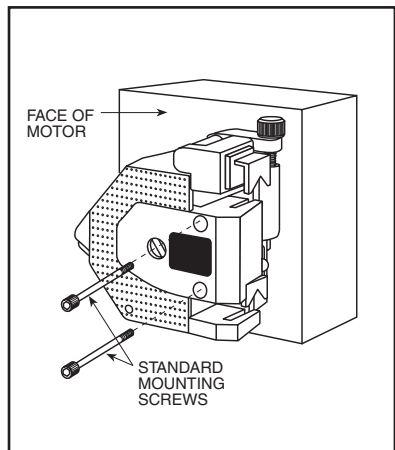

Figure 3-4. Securing the Pump to the Motor

1. Refer to Figure 3-1. Make sure the pump is in the closed position.
2. Refer to Figure 3-2 and Figure A. Place the blade of a flathead screwdriver in the groove of the Rotor Shaft (5). Rotate the Rotor Shaft until its back tab slips into the groove of the motor shaft. Do not try to force the pump onto the motor until you perform Step #3.
3. Refer to Figure 3-3 and Figure A. Swivel the pump back and forth slightly to align the holes on the back of the base (8) with the alignment pins on the face of the motor. Press the pump base up against the face of the motor.
4. Refer to Figure 3-4. With the pump and motor aligned, insert the mounting screws through the mounting holes in the pump, until they make contact with the threaded mounting holes in the face of the motor.
5. Tighten the screws fully with a $\frac{3}{64}$ (M3.5) allen wrench.

Parts of the Pump

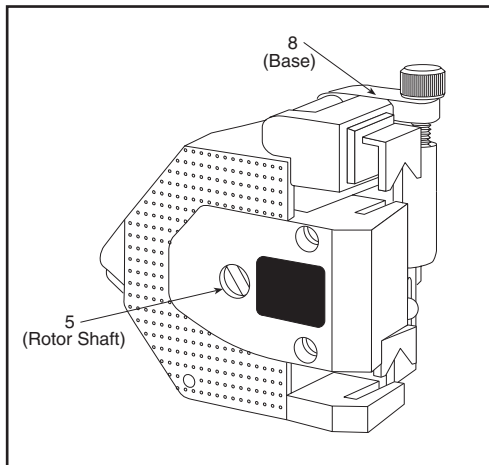

Figure A

3.3.2 Stacking Two Pumps onto One Motor

Refer to Figures 3-5 through 3-7 and Figure B.

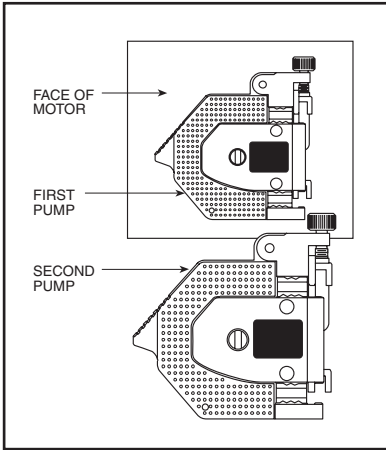

Figure 3-5. Placing the Second Pump on Top of the First Pump

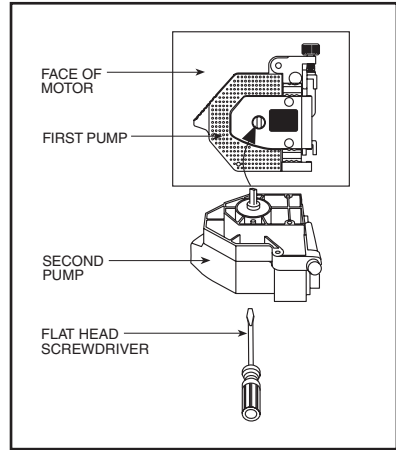

Figure 3-6. Aligning the Rotor Shaft of the Second Pump

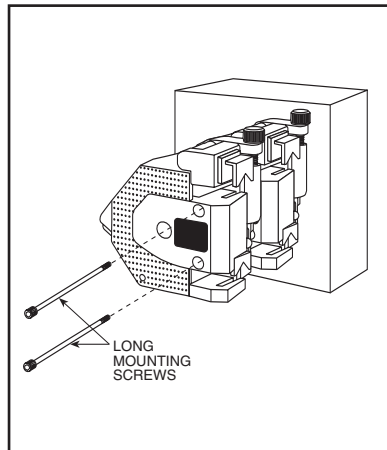

Figure 3-7. Securing Both Pumps to the Motor

1. Refer to Figures 3-1 through 3-3. Perform Steps 1, 2 and 3 in Section 3.3.1 to put the first pump on the face of the motor.
2. Refer to Figure 3-5 and Figure B. Make sure the second pump is in the closed position.
3. Refer to Figure 3-6 and Figure B. Place the blade of the flathead screwdriver in the groove of the Rotor Shaft (5) of the second pump. Rotate the Rotor Shaft of the second pump until it's back tab slips into the groove of the Rotor Shaft of the first pump.
4. Refer to Figure 3-7. With the pumps and motor aligned, insert the optional LONG mounting screws through the mounting holes in both pumps, until they make contact with the threaded mounting holes in the motor.
5. Tighten the long screws fully with a small flathead screwdriver.

For technical details on stacking more than 2 pumps, refer to Chapter 8.

Parts of the Pump

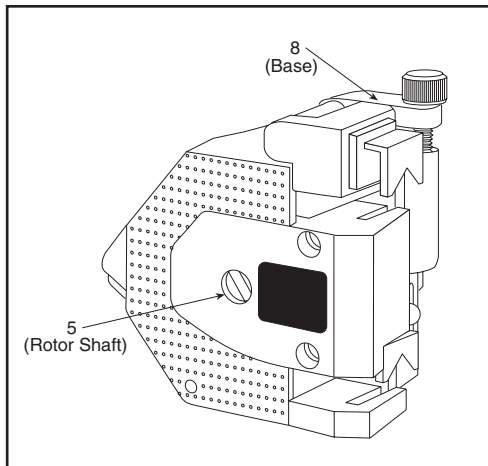

Figure B

3.3.3 Attaching a Single Pump to an Adapter Plate

Refer to Figures 3-8 through 3-11 and Figure C.

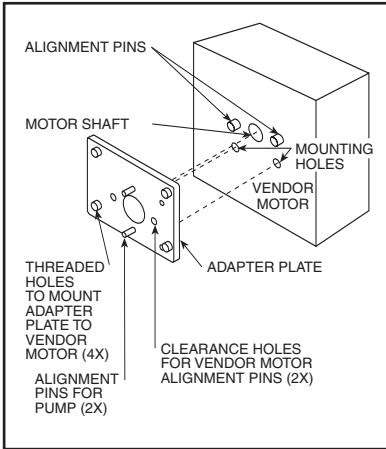

Figure 3-8. Mounting the Adapter Plate

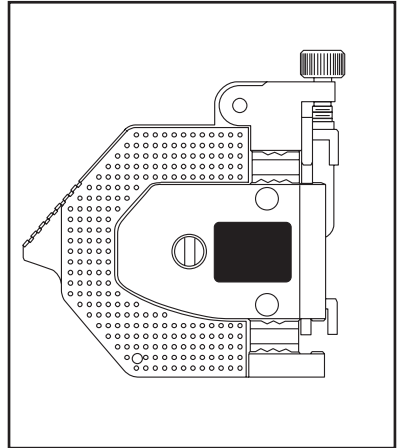

Figure 3-9. Pump in Closed Position

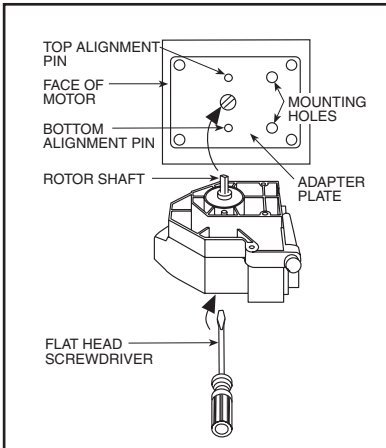

Figure 3-10. Aligning the Pump with the Plate

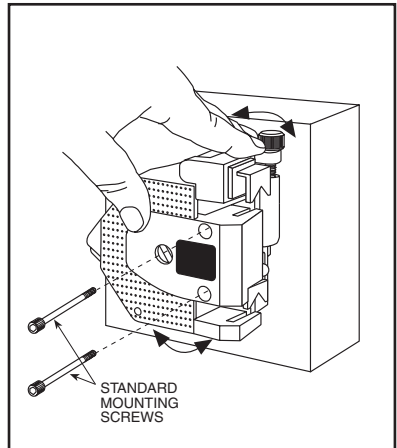

Figure 3-11. Securing the Pump to the Plate

The adapter plate is designed to have the same alignment pins and mounting holes as the front face of the standard pump motor. It acts as an interface between a non-standard pump motor and the peristaltic pump. The non-standard pump motor must have a motor shaft groove large enough to accept the the pump rotor shaft. It must also have at least two 8-32 mounting holes aligned with those on the adapter plate (refer to Figure 3-12).

Mounting the adapter plate to the motor (refer to Figure 3-8)

1. Align the plate so that the clearance holes fit over the alignment pins (on some units) of the non-standard motor.
2. Using the four 8-32 screws provided, attach the adapter plate to the motor.

Mounting the pump to the adapter plate

3. Make sure the pump is in the closed position. Refer to Figure 3-9.
4. Refer to Figure 3-10 and Figure C. Place the blade of a flathead screwdriver in the groove of the Rotor Shaft (5). Rotate the Rotor Shaft until its back tab slips into the groove of the motor shaft. Do not try to force the pump onto the motor until you perform Step #5.
5. Refer to Figure 3-11 and Figure C. Swivel the pump back and forth slightly to align the holes on the back of the base (8) with the pins on the adapter plate. Press the pump base up against the face of the motor.
6. Refer to Figure 3-11. With the pump and motor aligned, insert the mounting screws through the mounting holes in the pump, until they make contact with the threaded mounting holes in the adapter plate.
7. Tighten the screws fully with a $\frac{3}{64}$ (M3.5) allen wrench.

Parts of the Pump

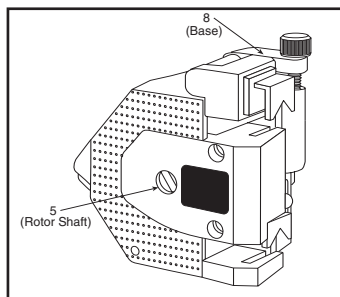

Figure C

3.3.4 Using Your Own Adapter Plate

Figure 3-12 shows the dimensions of the front of the pump and the rear of the pump. These diagrams enable you to locate and drill out the proper size holes so you can mount the pump to a motor using your own adapter plate.

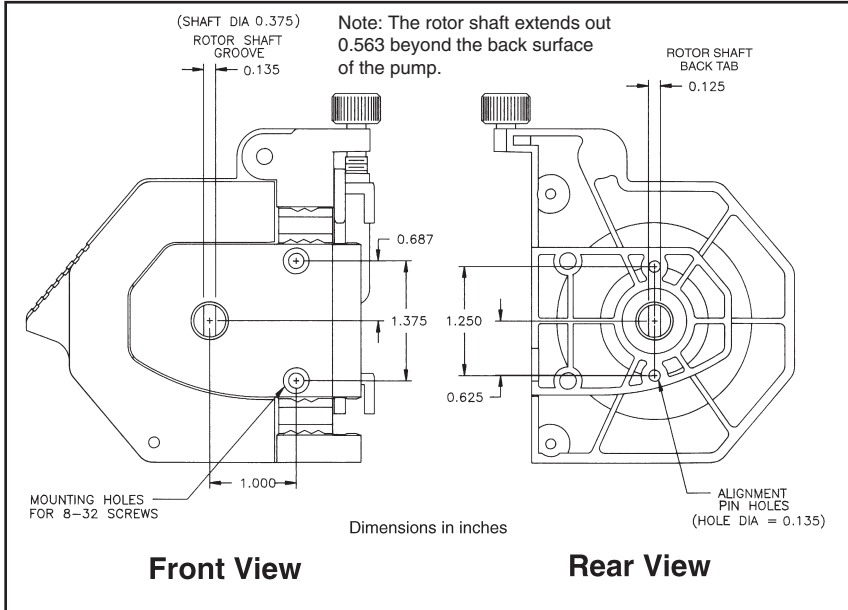

Figure 3-12. Dimensions of the Pump

Notes

4.1 Selecting Tubing

Select a tubing material and size that is right for your application (the fluid and flow rate that you are pumping).

Table 9-2 in Chapter 9, shows the average flow rates for different size tubing. Normalized flow rates (mL per revolution) vary significantly, based on motor speed, tubing materials, viscosity, and mechanical tolerances in pump dimensions. Table 9-3 outlines the variances resulting from differences in motor speed, tubing materials, and mechanical tolerances. Table 9-5 outlines the variances due to the difference in viscosity.

To determine the chemical compatibility of a particular tubing material, it is recommended that you test the tubing under actual conditions.

Tubing materials that can be used include Vinyl, Viton, Tygon, Silicone, Santoprene, and Norprene. Up to 68 durometer tubing can be used.

NOTE

Poor tubing life results were obtained for $\frac{5}{16}$ " (8.0mm) inner diameter Santoprene tubing. This particular tubing should not be used with the pump.

4.2 Tubing Life

Over time and high speeds, flow rates will drop as the tubing wears out. Tubing life for various materials and sizes are shown in Table 9-4 in Chapter 9. Tubing should be periodically inspected for wear. Either move the tubing to a fresh section, or replace tubing entirely (refer to Chapter 5).

5.1 Introduction

This chapter discusses the following topics:

- Loading the tubing (Section 5.2)
- Operating the Pump (Section 5.3) and
- Adjusting the Clamp Screw (Section 5.4).

Read each section thoroughly to guarantee successful pump operation.

5.2 Loading the Tubing

NOTE

Before you load the tubing in the pump, make sure that power to the motor is turned off and that the rotor has come to a complete stop. The rotor is partially exposed when the pump is in the open position.

Follow this procedure (refer to Figures 5-1 through 5-4 and Figure D):

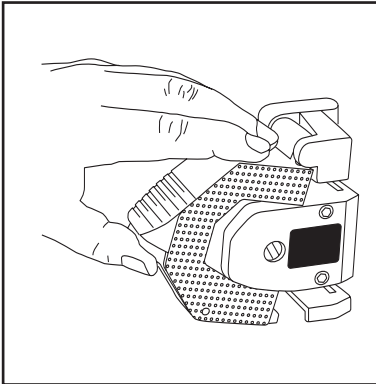

Figure 5-1. Opening the Stator

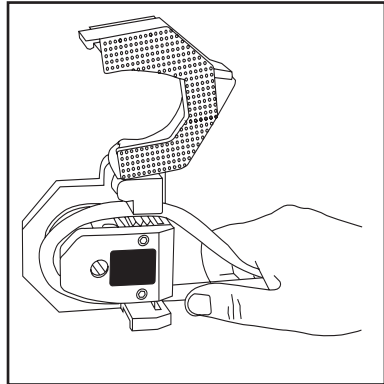

Figure 5-2. Loading the Tubing

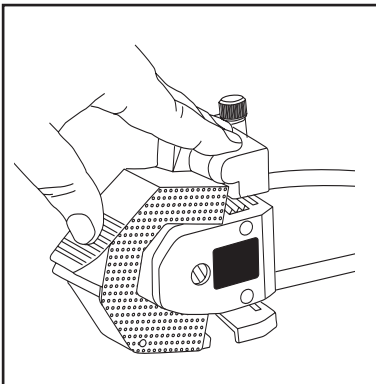

Figure 5-3. Closing the Stator

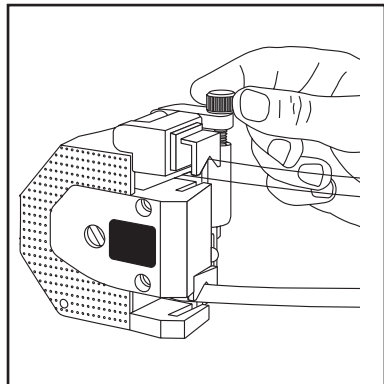

Figure 5-4. Adjusting the Clamp Screw

1. Refer to Figure 5-1 and Figure D. Snap open the Stator (1) by pushing the spring-loaded area of the Latch (2). Remove any old tubing from the pump, if necessary.
2. Refer to Figure 5-2 and Figure D. Loop the Tubing (10) over the rollers. This is easy to do for stacked pumps.

NOTE

Tubing can be changed on stacked pumps without detaching either of the pumps from the motor.

3. Refer to Figure 5-3. Push the stator closed until you hear the latch engage.
4. Refer to Figure 5-4. Tighten the Clamp Screw (4) until the Clamp Plate (3) contacts the tubing, securing it in place.

Parts of the Pump

Figure D

5.3 Operating the Pump

With the pump set up, adjust all control settings for the pump motor and start pumping. Figure 5-5 shows fluid flow directions with respect to motor directions.

Extensive testing has shown that the minimum motor speed required to prime the tubing varies significantly with the size of the tubing. These variances are shown in Table 9-1 in Chapter 9. If the tubing will not prime regardless of motor speed, simply press on the stator (refer to Figure 5-3) while the stator is shut and the motor is running. Pressing on the stator enhances the priming action of the pump. Release the pressure after the tubing is primed.

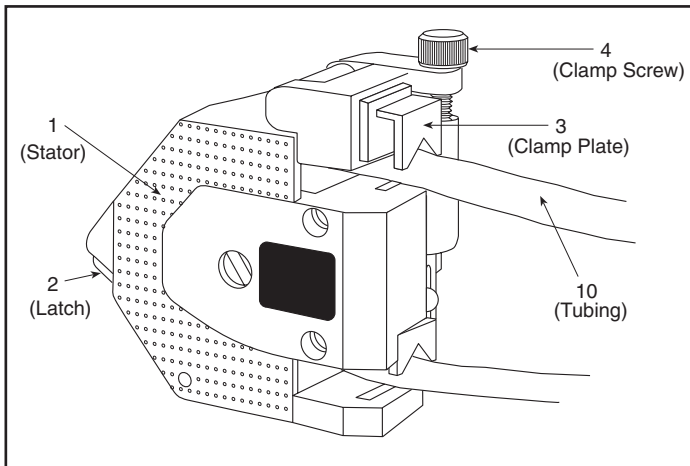
NOTE

Make sure that the stator is fully latched before motor power is turned on. If the motor is turning, and the stator is unlatched for any reason, make sure to keep fingers and clothing away from the moving rotor assembly until the motor is turned off and the rotor assembly comes to a complete stop.

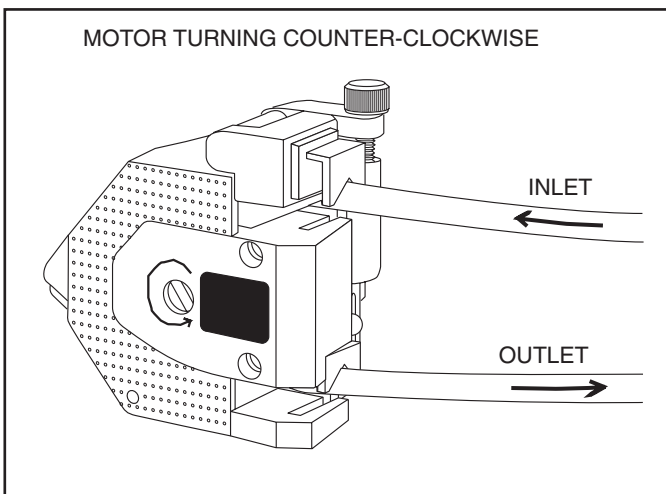

Figure 5-5a. Inlet and Outlet Flow

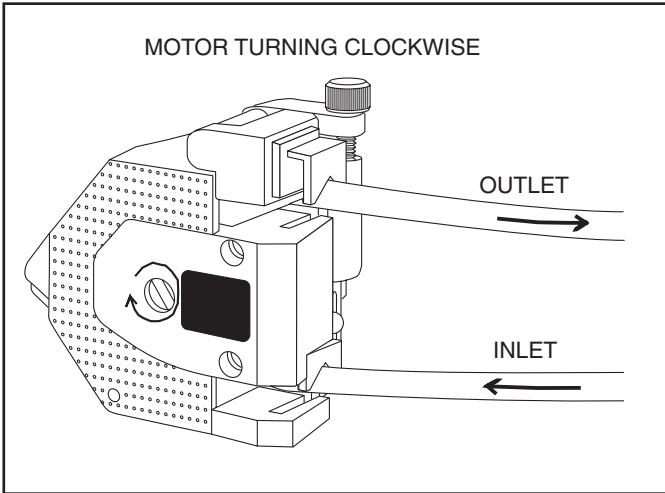

Figure 5-5b. Inlet and Outlet Flow

5.4 Adjusting the Clamp Screw

Once you start the pump, you may need to adjust the Clamp Screw (4) slightly, to prevent the tube from creeping (moving) through the pump. Creeping tends to occur on tubing of larger sizes and tubing made from low friction materials (for example, Santoprene). Use the following procedure to eliminate creeping. Refer to Figure 5-6.

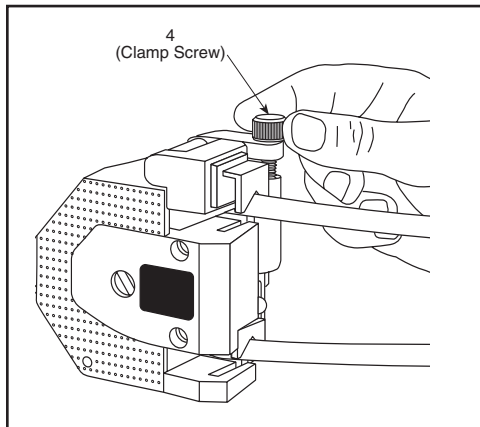

Figure 5-6. Adjusting the Clamp Screw

1. Turn the pump motor off.
2. Rotate the clamp screw a quarter turn clockwise, in order to increase the pressure of the clamp plate on the tube.
3. Turn the motor power back on and observe the tubing. If the tubing has not stopped creeping, go back to Step 1. Otherwise, continue pumping.

Notes

6.1 Introduction

- No lubrication is required for the pump. All bearings are pre-sealed and rated for long life.
- After many hours of use, fine particles of tubing will tend to accumulate inside the pump and on the rollers. Use a high pressure air hose (60 PSI) to blow out most of the particles from the pump. Clean all parts with a mild soap solution or a light mineral oil.
- The pump may be dismantled either for cleaning or for replacing the rotor assembly in case of a malfunction. Follow the procedure in Section 6.2 to replace the rotor assembly.

6.2 Replacing the Rotor Assembly (Part Number FPU500-RA)

In the replacement kit you will find one Rotor Assembly (13) and two Washers (12).

Figure 6-1 shows the exploded view of the pump.

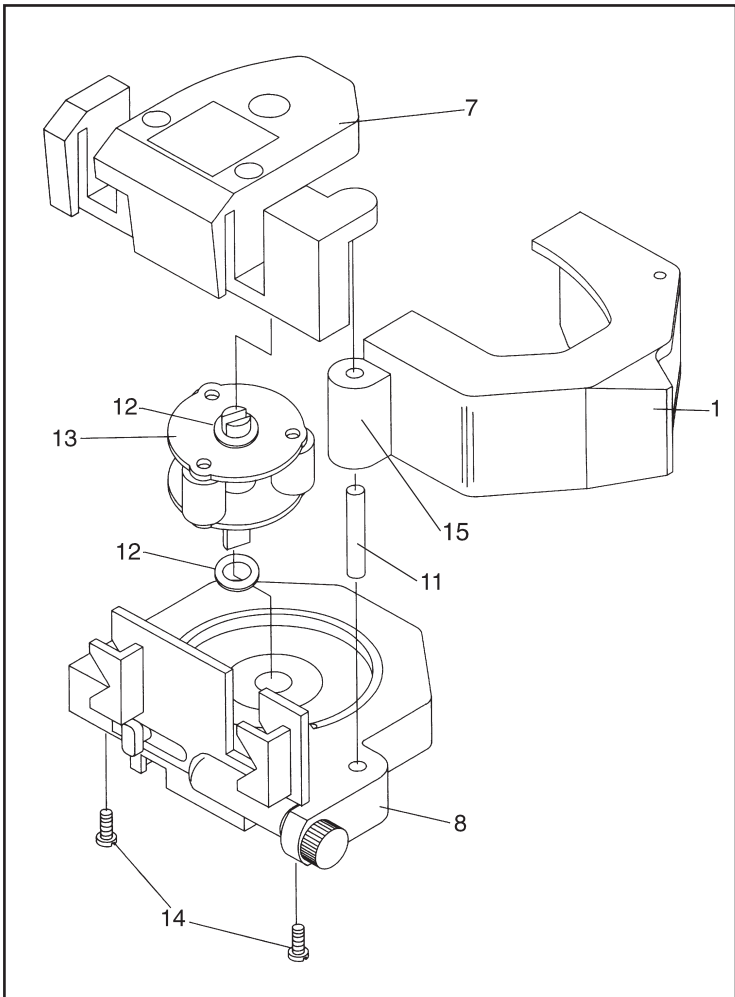

Figure 6-1. Exploded View of the Pump

1. Using a phillips head screwdriver, remove the two #6 Self-Tapping Screws (14) on the back of the base that hold the pump together.
2. Pull apart the three major plastic assemblies in the pump – the Lower Shield (7), Base (8), and Stator (1) Assemblies. A $\frac{3}{16}$ " x $1\frac{1}{4}$ " long Alignment Pin (11) aligns the three assemblies and can be left sitting in the base. The Rotor Assembly (13) rotates within ball bearings pressed into the Base and Lower Shield. Two Washers (12) prevent the Rotor Assembly from hitting the bearings.
3. Replace the Rotor Assembly and Washers with new ones.
4. Reassemble all parts.
 - a. Slip one washer onto the bottom of the Rotor Shaft. Slip the bottom of the Rotor Shaft through the bearing pressed into the Base.
 - b. Add the second washer onto the top of the Rotor Shaft.
 - c. Place the Alignment Pin (11) in the mounting hole in the Base.
 - d. Slip the Boss (15) in the Stator Assembly over the alignment pin, until the bottom of the Boss makes contact with the base.
 - e. Bring the Lower Shield Assembly down, so that the following four assembly actions occur:
 - i. The top of the Rotor Shaft fits through the bearing pressed into the Lower Shield.
 - ii. The Boss in the Lower Shield fits over the alignment pin.
 - iii. The slot in the Lower Shield fits over the Clamp Plate.
 - iv. The bottom of the Lower Shield is flush with the Base.
 - f. Attach the Base to the Lower Shield with the two #6 Self-Tapping Screws.

Problem	Solution
No flow out of the outlet tubing	<ol style="list-style-type: none"><li data-bbox="511 329 917 477">1. Check to see that the Stator is snapped shut. If it is, push down on the Stator while the motor is running. This action enhances the self-priming capability of the pump.<li data-bbox="511 493 917 607">2. Make sure the tubing is loaded properly. The tubing should be centered in the middle of the rollers. Reload if necessary.<li data-bbox="511 623 917 704">3. Check to see that the tubing has no holes or cracks. Replace with new tubing, if necessary.<li data-bbox="511 721 917 786">4. Check that the inlet tubing is fully immersed in fluid.<li data-bbox="511 802 917 883">5. Check that the motor is rotating in the correct direction. Refer to Figure 5-5.<li data-bbox="511 899 917 980">6. Check to see if the tubing is clogged. Replace with new tubing, if necessary.<li data-bbox="511 997 917 1110">7. Check to see if the pump is properly mounted to the motor. Refer to Section 3 for instructions on proper mounting.<li data-bbox="511 1127 917 1317">8. Check to see if the Rotor Assembly is worn or stuck. Check that the rollers spin freely. Use a high pressure air hose to blow out particles from the pump which may be restricting roller motion.



Problem	Solution
Fluid flows in the opposite direction of what is intended	<ol style="list-style-type: none"> 1. Check tubing connections to source and drain containers. 2. Check that the motor is rotating in the correct direction. Refer to Figure 5-5.
Fluid flow direction cannot be reversed	The motor only turns in one direction. Make sure you use a bi-directional motor.
The tube moves when pumping	Adjust the Clamp Screw. Refer to Section 5.4.
The Stator will not snap shut	<ol style="list-style-type: none"> 1. Make sure the tubing is loaded properly. The tubing should be centered in the middle of the rollers. 2. Make sure the tubing wall thickness is correct (refer to Table 9-1). 3. The tubing inside diameter may be too large for the pump. (refer to Table 9-1). 4. The tubing durometer may be too high for the pump (refer to Chapter 9). 5. The tubing may be caught on the bottom roller. Reposition the roller slightly and load the tubing again.
Screws are too short to fasten two stacked pumps to the motor	Use long mounting screws (Part Number FPU500-LMS)

Problem	Solution
<p>Motor will not turn</p>	<ol style="list-style-type: none"> 1. Make sure the tubing is loaded properly. The tubing should be centered in the middle of the rollers. Reload if necessary. 2. Check to see if the motor is turned on. 3. Check motor fuse.
<p>Motor will not turn – overcurrent condition</p>	<ol style="list-style-type: none"> 1. Make sure the tubing is loaded properly. The tubing should be centered in the middle of the rollers. 2. Make sure the tubing wall thickness is correct (refer to Table 9-1). 3. The tubing durometer may be too high for the pump (refer to Chapter 9). 4. The tubing may be caught on the bottom roller. Reposition the roller slightly and load the tubing again.
<p>The pump will not stay on the motor</p>	<ol style="list-style-type: none"> 1. The pump is not properly mounted to the motor. Refer to Section 3. 2. The mounting screws are loose. Tighten the screws, if necessary.

Notes

8.1 Theory of Operation

A peristaltic pump is a fluid pump which operates to create a moving region of compression along a flexible tube. The motion of the compressed region of the tube along its axis forces fluid ahead and creates a partial vacuum behind the region. This partial vacuum forces more fluid forward. The pump has a Rotor Assembly which rotates an attached set of rollers up against a tube backed by a fixed circular wall called the Stator. The rotary motion of the Rotor Assembly around the center axis of the pump forms the region of moving compression in the tube.

8.2 Design Considerations

One side effect of the friction between the Rollers and the tube is a net force on the tube in its axial direction. When unchecked, this force tends to cause the tube to “creep” or move forward. A pump must have some type of mechanism to counter this force. In addition, it must give customers the ability to change the tubing quickly, to use the same pump with a wide variety of tube diameters and materials, and to stack more than one pump onto a motor.

8.3 Design Solution

The peristaltic pump provides a novel solution to today’s customer needs. In this design a Rotor Assembly consists of two stainless steel rotors which sandwich three rollers between ball bearings. The Rotor Assembly is rotated by a Rotor Shaft, driven by a pump motor. The Rotor Assembly is supported by a pump base. A stator is mounted to the Base and acts as a tubing compression surface for peristaltic pumping of fluid when in the closed position. In addition, the tight fit of the mating areas of the Stator and the Lower Shield (also mounted to the Base) acts to fully enclose the pump region. This enclosure prevents splashing of fluid in the event that the tubing fails and fluid leaks.

Because of the back tab and groove found in the Rotor Shaft design, pumps can be stacked one on top of another and attached to a common pump motor. Only one motor needs to be purchased to pump fluid between several different containers.

The Latch Assembly of the pump allows the Stator to be easily opened and closed, allowing for quick tubing changes. Push a spring-loaded area on the Latch to open the Stator. Push the Stator shut and it snaps into place. The pump dimensions are set to allow pumping of tubing with a broad range of sizes. A Clamp Screw actuates a Clamp Plate. This plate pushes the tubing against two walls in the Lower Shield, acting to prevent the tubing from creeping. The Clamp Screw and Clamp Plate are designed with sufficient travel to prevent "creeping" in a broad range of tube sizes.

8.4 Stacking More than Two Pumps

Optional mounting screws are available to stack two pumps. However, the number of pumps that can be stacked is limited only by the motor power available. In general, up to $\frac{1}{20}$ horsepower (38 watts) of motor power is required to operate each pump up to 600 RPM.

Table 9-1. Tubing Size vs Min. Motor Speed Required for Priming *

Tubing Size - ID	Minimum Motor Speed (RPM)
1/32"	300
1/16"	250
1/8"	100
3/16"	50
1/4"	50
5/16"	50
1 mm	300
2mm	250
3mm	100
4mm	50
5mm	50
6mm	50
7mm	50
8mm	50

(* Tests are done using 20°C water, 0 PSI back pressure)

Maximum Fluid Back Pressure:	20 PSI
Tube Wall Thickness Required:	1/16" (1.5 mm)
Tube Inner Diameter Range:	1/32" to 5/16" (1 mm to 8 mm)
Tubing Materials:	Vinyl, Viton, Tygon, Silicone, Santoprene, and Norprene
Tubing Durometer:	68 or less
Fluid Temperature Range:	-50°F to 300°F (-46°C to 149°C)

Pump Dimensions (H x W x D):	4" x 4" x 2¼" (102 x 102 x 57 mm)
Pump Weight:	0.9 lb (0.4 kg)
Adapter Plate Dimensions (H x W x D):	3" x 2½" x ⅛" (76 x 64 x 3.2 mm)
Adapter Plate Weight:	0.2 lb (0.1 kg)
Speed Range:	10 to 600 RPM (adjustable via motor settings)
Flow Direction:	Bi-directional
Motor Power Required for Two Pumps to Operate at 600 RPM:	⅓ HP (75 Watts)
Pump Housing:	Polysulfone material, all plastic parts
Rotor Assembly:	Stainless steel rotor and rollers
Max. Suction Lift:	20 feet of H ₂ O (6.1 meters of H ₂ O)

Flow rate tests were done with 20°C water at 0 PSI back pressure.

Table 9-2. Average Flow Rates

Tubing Wall Thickness	Tubing Size Inner Diameter	mL per Revolution	Minimum Flow Rate at 600 RPM (mL/Minute)	Maximum Flow Rate at 600 RPM (mL/Minute)
⅛"	⅓₂"	0.05	1	30
⅛"	⅛"	0.22	3	132
⅛"	⅛"	0.9	9	540
⅛"	⅜"	1.9	19	1140
⅛"	¼"	3.0	30	1800
⅛"	⅝"	3.8	38	2280
1.5 mm	1.0 mm	0.08*	1	48
1.5 mm	2.0 mm	0.35*	4	210

Table 9-2. Average Flow Rates (Cont'd)

Tubing Wall Thickness	Tubing Size Inner Diameter	mL per Revolution	Minimum Flow Rate at 600 RPM (mL/Minute)	Maximum Flow Rate at 600 RPM (mL/Minute)
1.5 mm	3.0 mm	0.8*	8	482
1.5 mm	4.0 mm	1.43*	15	857
1.5 mm	5.0 mm	2.1*	21	1257
1.5 mm	6.0 mm	2.7*	27	1607
1.5 mm	7.0 mm	3.6*	37	2187
1.5 mm	8.0 mm	3.9*	39	2316

* Metric mL per Revolution numbers are rounded off

Normalized flow rates (mL per revolution) vary significantly, based on motor speed, tubing materials, and mechanical tolerances in pump dimensions. In addition, the variances are different for the different tubing dimensions. Variances from the normalized flow rates of Table 9-2 are shown below. The data is shown for new tubing only.

Tubing operating life tests are done at 600 RPM, with 20°C water, 0 PSI back pressure until the tubing breaks

Table 9-3. Variances in Normalized Flow Rate (mL per Revolution)

Tubing Size Inner Diameter (in.)	Due to Motor Speed	Between Pumps (due to Mechanical Tolerances)	Due to Different Tubing Materials
1/2	±10%	±25%	±20%
1/6	±10%	±15%	±15%
1/8	±10%	±10%	±5%
3/6	±5%	±10%	±5%
1/4	±5%	±15%	±5%
5/6	±15%	±20%	±10%

Tubing operating life test were done at 600 RPM, with 20°C water, 0 PSI, back pressure until the tubing breaks. Average tubing life hours are shown. However, tubing life varies considerably depending on tubing formulation, tubing back pressure, and fluid pumped. Tubing should be inspected periodically for wear.

Table 9-4. Average Tubing Life

Tubing Wall Thickness (in.)	Tubing Wall Thickness (mm)	Tubing Inner Diameter (in.)	Tubing Inner Diameter (mm)	Material	Average Tubing Life (Hours)
1/6	1.5	1/6	1.5	Viton	10
1/6	1.5	1/8	3.0	Viton	25
1/6	1.5	3/6	4.5	Viton	25
1/6	1.5	1/4	6.0	Viton	25
1/6	1.5	5/6	8.0	Viton	10
1/6	1.5	1/6	1.5	Tygon	60
1/6	1.5	1/8	3.0	Tygon	60
1/6	1.5	3/6	4.5	Tygon	30
1/6	1.5	1/4	6.0	Tygon	30
1/6	1.5	5/6	8.0	Tygon	30
1/6	1.5	1/6	1.5	Silicone	60
1/6	1.5	1/8	3.0	Silicone	60
1/6	1.5	3/6	4.5	Silicone	60
1/6	1.5	1/4	6.0	Silicone	50
1/6	1.5	5/6	8.0	Silicone	40
1/6	1.5	1/6	1.5	Santoprene	100
1/6	1.5	1/8	3.0	Santoprene	100
1/6	1.5	3/6	4.5	Santoprene	100
1/6	1.5	1/4	6.0	Santoprene	75

NOTE: Poor tubing life results were obtained for 3/6" (8.0mm) inner diameter Santoprene tubing. This particular tubing should not be used with the FPU-500 Pump.

Table 9-4. Average Tubing Life (Cont'd)

$\frac{1}{16}$	1.5	$\frac{1}{16}$	1.5	Vinyl	60
$\frac{1}{16}$	1.5	$\frac{1}{8}$	3.0	Vinyl	60
$\frac{1}{16}$	1.5	$\frac{3}{16}$	4.5	Vinyl	60
$\frac{1}{16}$	1.5	$\frac{1}{4}$	6.0	Vinyl	40
$\frac{1}{16}$	1.5	$\frac{5}{16}$	8.0	Vinyl	30
$\frac{1}{16}$	1.5	$\frac{1}{16}$	1.5	Norprene	500
$\frac{1}{16}$	1.5	$\frac{1}{8}$	3.0	Norprene	500
$\frac{1}{16}$	1.5	$\frac{3}{16}$	4.5	Norprene	500
$\frac{1}{16}$	1.5	$\frac{1}{4}$	6.0	Norprene	400
$\frac{1}{16}$	1.5	$\frac{5}{16}$	8.0	Norprene	400

Table 9-6. Average Flow Rates for Viscous Liquids

Liquid	Tubing Size		mL per Revolution	Viscosity
	Tubing Wall Thickness	Inner Diameter		
Mineral Oil	$\frac{1}{16}$ "	$\frac{1}{32}$ "	0	400 cps
Mineral Oil	$\frac{1}{16}$ "	$\frac{1}{16}$ "	0.005	400 cps
Mineral Oil	$\frac{1}{16}$ "	$\frac{1}{8}$ "	0.04	400 cps
Mineral Oil	$\frac{1}{16}$ "	$\frac{3}{16}$ "	0.15	400 cps
Mineral Oil	$\frac{1}{16}$ "	$\frac{1}{4}$ "	0.20	400 cps
Mineral Oil	$\frac{1}{16}$ "	$\frac{5}{16}$ "	0.25	400 cps
Molasses	$\frac{1}{16}$ "	$\frac{1}{32}$ "	0	8,000 cps
Molasses	$\frac{1}{16}$ "	$\frac{1}{16}$ "	0.002	8,000 cps
Molasses	$\frac{1}{16}$ "	$\frac{1}{8}$ "	0.01	8,000 cps
Molasses	$\frac{1}{16}$ "	$\frac{3}{16}$ "	0.07	8,000 cps
Molasses	$\frac{1}{16}$ "	$\frac{1}{4}$ "	0.08	8,000 cps
Molasses	$\frac{1}{16}$ "	$\frac{5}{16}$ "	0.10	8,000 cps

Flow rate tests were done with 20°C liquids at 0 psi back pressure

Notes

Table 10-1. Spare Parts

Part Number	Description
FPU500-SMS	Standard Length Mounting Screws
FPU500-LMS	Long Mounting Screws
FPU500-AP	Adapter Plate Assembly
FPU500-RA	Rotor Assembly (including washers)

Table 10-2. Accessories

Part Number *	Tubing Type	Size (OD x ID)	Durometer (Shore Hardness)
RECOMMENDED TUBING TYPES AND SIZES			
TYVY Series	Vinyl	$\frac{3}{16} \times \frac{1}{16}$	68
TYVY Series	Vinyl	$\frac{1}{4} \times \frac{1}{8}$	68
TYVY Series	Vinyl	$\frac{5}{32} \times \frac{1}{32}$	68
TYVY Series	Vinyl	$\frac{5}{16} \times \frac{3}{16}$	68
TYVY Series	Vinyl	$\frac{3}{8} \times \frac{1}{4}$	68
TYVY Series	Vinyl	$\frac{7}{16} \times \frac{5}{16}$	68
TYSP Series	Santoprene	$\frac{3}{16} \times \frac{1}{16}$	55 & 64
TYSP Series	Santoprene	$\frac{1}{4} \times \frac{1}{8}$	55 & 64
TYSP Series	Santoprene	$\frac{5}{16} \times \frac{3}{16}$	55 & 64
TYSP Series	Santoprene	$\frac{3}{8} \times \frac{1}{4}$	55 & 64

* Contact the Sales Department for the specific part numbers of the tubing you wish to purchase.

Table 10-2. Accessories (cont'd)

Part Number *	Tubing Type	Size (OD x ID)	Durometer (Shore Hardness)
RECOMMENDED TUBING TYPES AND SIZES			
TYTY Series	Tygon	$\frac{1}{4} \times \frac{1}{8}$	55
TYTY Series	Tygon	$\frac{5}{16} \times \frac{3}{16}$	55
TYTY Series	Tygon	$\frac{3}{8} \times \frac{1}{4}$	55
TYTY Series	Tygon	$\frac{7}{16} \times \frac{5}{16}$	55
TYSC Series	Silicone	$\frac{1}{4} \times \frac{1}{8}$	50 & 60
TYSC Series	Silicone	$\frac{5}{16} \times \frac{3}{16}$	50 & 60
TYSC Series	Silicone	$\frac{3}{8} \times \frac{1}{4}$	50 & 60
TYSC Series	Silicone	$\frac{7}{16} \times \frac{5}{16}$	50 & 60
TYNP Series	Norprene	$\frac{3}{16} \times \frac{1}{16}$	50
TYNP Series	Norprene	$\frac{1}{4} \times \frac{1}{8}$	50
TYNP Series	Norprene	$\frac{5}{16} \times \frac{3}{16}$	50
TYNP Series	Norprene	$\frac{3}{8} \times \frac{1}{4}$	50
TYNP Series	Norprene	$\frac{7}{16} \times \frac{5}{16}$	50
TYVT Series	Viton	$\frac{3}{16} \times \frac{1}{16}$	60
TYVT Series	Viton	$\frac{1}{4} \times \frac{1}{8}$	60
TYVT Series	Viton	$\frac{5}{32} \times \frac{1}{32}$	60
TYVT Series	Viton	$\frac{5}{16} \times \frac{3}{16}$	60
TYVT Series	Viton	$\frac{3}{8} \times \frac{1}{4}$	60
TYVT Series	Viton	$\frac{7}{16} \times \frac{5}{16}$	60

* Contact the Sales Department for the specific part numbers of the tubing you wish to purchase.

You can use an optional Peristaltic Pump Motor (Part Number FPU5-MT) to run the pumps. Figure 10-1 shows the motor. You can attach one pump to each side of the motor or two pumps to either side.

Contact Sales for more information about the pump motor.

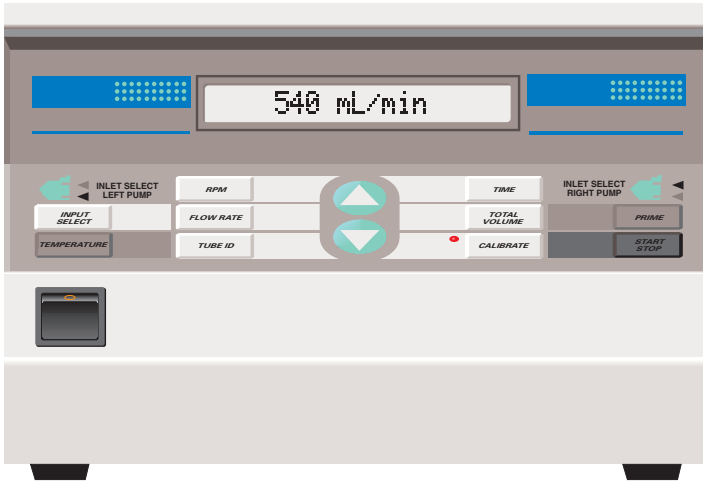

Figure 10-1. Peristaltic Pump Motor

Notes



WARRANTY/DISCLAIMER

OMEGA ENGINEERING, INC. warrants this unit to be free of defects in materials and workmanship for a period of **25 months** from date of purchase. OMEGA's WARRANTY adds an additional one (1) month grace period to the normal **two (2) year product warranty** to cover handling and shipping time. This ensures that OMEGA's customers receive maximum coverage on each product.

If the unit malfunctions, it must be returned to the factory for evaluation. OMEGA's Customer Service Department will issue an Authorized Return (AR) number immediately upon phone or written request. Upon examination by OMEGA, if the unit is found to be defective, it will be repaired or replaced at no charge. OMEGA's WARRANTY does not apply to defects resulting from any action of the purchaser, including but not limited to mishandling, improper interfacing, operation outside of design limits, improper repair, or unauthorized modification. This WARRANTY is VOID if the unit shows evidence of having been tampered with or shows evidence of having been damaged as a result of excessive corrosion; or current, heat, moisture or vibration; improper specification; misapplication; misuse or other operating conditions outside of OMEGA's control. Components in which wear is not warranted, include but are not limited to contact points, fuses, and triacs.

OMEGA is pleased to offer suggestions on the use of its various products. However, OMEGA neither assumes responsibility for any omissions or errors nor assumes liability for any damages that result from the use of its products in accordance with information provided by OMEGA, either verbal or written. OMEGA warrants only that the parts manufactured by the company will be as specified and free of defects. OMEGA MAKES NO OTHER WARRANTIES OR REPRESENTATIONS OF ANY KIND WHATSOEVER, EXPRESSED OR IMPLIED, EXCEPT THAT OF TITLE, AND ALL IMPLIED WARRANTIES INCLUDING ANY WARRANTY OF MERCHANTABILITY AND FITNESS FOR A PARTICULAR PURPOSE ARE HEREBY DISCLAIMED. LIMITATION OF LIABILITY: The remedies of purchaser set forth herein are exclusive, and the total liability of OMEGA with respect to this order, whether based on contract, warranty, negligence, indemnification, strict liability or otherwise, shall not exceed the purchase price of the component upon which liability is based. In no event shall OMEGA be liable for consequential, incidental or special damages.

CONDITIONS: Equipment sold by OMEGA is not intended to be used, nor shall it be used: (1) as a "Basic Component" under 10 CFR 21 (NRC), used in or with any nuclear installation or activity; or (2) in medical applications or used on humans. Should any Product(s) be used in or with any nuclear installation or activity, medical application, used on humans, or misused in any way, OMEGA assumes no responsibility as set forth in our basic WARRANTY/DISCLAIMER language, and, additionally, purchaser will indemnify OMEGA and hold OMEGA harmless from any liability or damage whatsoever arising out of the use of the Product(s) in such a manner.

RETURN REQUESTS/INQUIRIES

Direct all warranty and repair requests/inquiries to the OMEGA Customer Service Department. **BEFORE RETURNING ANY PRODUCT(S) TO OMEGA, PURCHASER MUST OBTAIN AN AUTHORIZED RETURN (AR) NUMBER FROM OMEGA'S CUSTOMER SERVICE DEPARTMENT (IN ORDER TO AVOID PROCESSING DELAYS).** The assigned AR number should then be marked on the outside of the return package and on any correspondence.

The purchaser is responsible for shipping charges, freight, insurance and proper packaging to prevent breakage in transit.

FOR **WARRANTY** RETURNS, please have the following information available BEFORE contacting OMEGA:

1. Purchase Order number under which the product was PURCHASED,
2. Model and serial number of the product under warranty, and
3. Repair instructions and/or specific problems relative to the product.

FOR **NON-WARRANTY** REPAIRS, consult OMEGA for current repair charges. Have the following information available BEFORE contacting OMEGA:

1. Purchase Order number to cover the COST of the repair,
2. Model and serial number of the product, and
3. Repair instructions and/or specific problems relative to the product.

OMEGA's policy is to make running changes, not model changes, whenever an improvement is possible. This affords our customers the latest in technology and engineering.

OMEGA is a registered trademark of OMEGA ENGINEERING, INC.

© Copyright 2005 OMEGA ENGINEERING, INC. All rights reserved. This document may not be copied, photocopied, reproduced, translated, or reduced to any electronic medium or machine-readable form, in whole or in part, without the prior written consent of OMEGA ENGINEERING, INC.

Where Do I Find Everything I Need for Process Measurement and Control? **OMEGA...Of Course!** *Shop online at omega.com*

TEMPERATURE

- ☑ Thermocouple, RTD & Thermistor Probes, Connectors, Panels & Assemblies
- ☑ Wire: Thermocouple, RTD & Thermistor
- ☑ Calibrators & Ice Point References
- ☑ Recorders, Controllers & Process Monitors
- ☑ Infrared Pyrometers

PRESSURE, STRAIN AND FORCE

- ☑ Transducers & Strain Gages
- ☑ Load Cells & Pressure Gages
- ☑ Displacement Transducers
- ☑ Instrumentation & Accessories

FLOW/LEVEL

- ☑ Rotameters, Gas Mass Flowmeters & Flow Computers
- ☑ Air Velocity Indicators
- ☑ Turbine/Paddlewheel Systems
- ☑ Totalizers & Batch Controllers

pH/CONDUCTIVITY

- ☑ pH Electrodes, Testers & Accessories
- ☑ Benchtop/Laboratory Meters
- ☑ Controllers, Calibrators, Simulators & Pumps
- ☑ Industrial pH & Conductivity Equipment

DATA ACQUISITION

- ☑ Data Acquisition & Engineering Software
- ☑ Communications-Based Acquisition Systems
- ☑ Plug-in Cards for Apple, IBM & Compatibles
- ☑ Datalogging Systems
- ☑ Recorders, Printers & Plotters

HEATERS

- ☑ Heating Cable
- ☑ Cartridge & Strip Heaters
- ☑ Immersion & Band Heaters
- ☑ Flexible Heaters
- ☑ Laboratory Heaters

ENVIRONMENTAL MONITORING AND CONTROL

- ☑ Metering & Control Instrumentation
- ☑ Refractometers
- ☑ Pumps & Tubing
- ☑ Air, Soil & Water Monitors
- ☑ Industrial Water & Wastewater Treatment
- ☑ pH, Conductivity & Dissolved Oxygen Instruments

M2219/0305

Free Manuals Download Website

<http://myh66.com>

<http://usermanuals.us>

<http://www.somanuals.com>

<http://www.4manuals.cc>

<http://www.manual-lib.com>

<http://www.404manual.com>

<http://www.luxmanual.com>

<http://aubethermostatmanual.com>

Golf course search by state

<http://golfingnear.com>

Email search by domain

<http://emailbydomain.com>

Auto manuals search

<http://auto.somanuals.com>

TV manuals search

<http://tv.somanuals.com>