

BEYOND IMAGINATION



ONKYO[®]
IMAGINATIVE SIGHT & SOUND

HOME THEATER

TX-NR5000E & DV-SP1000E

HOME THEATER

A LEAP IN THE EVOLUTION OF HOME CINEMA IS AN UNDERSTATEMENT OF EPIC PROPORTIONS

It is the belief of ONKYO that if a component does not deliver a performance that evokes emotion and fails to reproduce every nuance for you, then it has missed the fundamental reason it was created for. And this faithful reproduction of audio and video does not happen merely by chance. Since the release of the world's first THX certified receiver, we have maintained an enviable reputation as the leading innovator of how entertainment should be presented in the home environment. In 1994, ONKYO set the standard for quality and performance by partnering with THX Ltd. to provide the first cast-iron, guaranteed standard for the delivery of true home cinema. The result was the TX-SV919THX, the world's first THX certified receiver for the home cinema environment. A few years later, following advances in technology, the TX-DS939 came forth as the benchmark of what a home cinema receiver should be. The next ONKYO innovation to rock the home cinema industry was the world's first 7.1 channel home cinema receiver, the TX-DS989. At the same time as this momentous event, ONKYO released its first THX certified DVD player, the DV-S939. Today, evolution has taken another leap as we introduce the 1000 series—the TX-NR5000E and the DV-SP1000E. Now, experience for yourself what over 50 years of evolutionary achievement and rock-steady performance have progressed to.

1994
Receiver
TX-SV919THX

1996
Receiver
TX-SV828THX
TX-DS939

1999
Receiver
TX-DS777

2000
Receiver
TX-DS787
TX-DS989
DVD Player
DV-S939

2001
Receiver
TX-DS797
TX-DS898
DVD Player
DV-S757

2002
Receiver
TX-SR800E
TX-NR900E
DVD Player
DV-SP800

2003
Receiver
TX-SR701E
TX-NR801E



TX-SV919THX



TX-DS939



DV-S939



TX-DS989



TX-NR900E



DV-SP800

THE FEATURES OF EVOLUTION

NET-TUNE



Do you have MP3, WAV, or WMA audio files on your computer? Now you can add new life to your existing content and enjoy it in glorious surround sound. With ONKYO's exclusive line of network-ready receivers connected to your computer via a broadband router, you can easily access all your computer's music files. Simply download Net-Tune to your PC and through the Net-Tune Central application, you're ready to truly fill your room with music. If you've already upgraded to a broadband Internet connection, then there are even more possibilities for you. Feel the urge to hear pop music from around Europe or the latest songs soaring up the Asian charts? How does instant access to radio stations around the world grab you? Well, it's possible through the mini-revolution in the music world called Internet radio. The process is simple. Hook-up your receiver to a router connected to your broadband modem via a high-speed Ethernet cable. Press the Net Audio button on the front or on your remote, and you'll be enjoying a new world of music in your home.

VLSC (Vector Linear Shaping Circuitry)



Conventional D/A conversion methods reduce digital pulse noise at the conversion stage but can't remove it completely. Digital-to-analogue converters (DACs) and surrounding circuitry inevitably taint the analogue signal with pulse noise. This pulse noise is transmitted along with the analogue signal and out to your speakers for a harsher sound signal than you should have to endure.

ONKYO's VLSC (Vector Linear Shaping Circuitry) employs a custom D/A conversion circuit to overcome this problem. Data is converted between sampling points. The first sampling point is compared to the following sampling point via the Signal Comparison Generator, and the difference is then fed back to the Vector Generator. This process is carried out in a continuous loop throughout the duration of your usage. These points are joined with analogue vectors in real-time to produce a smooth output waveform. The result—a smooth analogue signal based on the digital source, virtually free of the tainting pulse noise, which brings out even the most subtle of nuances in your music, movie soundtracks and even MP3s!

HDMI (High-Definition Multimedia Interface)



The World of digital connection for consumer products has been elevated to the next level with a groundbreaking, all-digital connection that goes by the name of HDMI. While the name may be imposing HDMI simplifies wiring by doing away with the myriad cables required for a state-of-the-art home entertainment system. Unparalleled amounts of uncompressed data—not only video but audio as well—can be streamed to digital devices. Up to 5 Gbps—more than twice the 2.2 Gbps needed for an HD movie with surround sound—with plenty of room left over for what the future holds from a single cable. Convenient. One HDMI cable has the ability to replace audio and video cables giving you a single connection between your digital components. HDMI is also the first interface able to support every high-definition video—NTSC and PAL, from 480i to 1080p—and audio—DTS, Dolby Digital, PCM, etc.—format. There is even backward compatibility with DVI devices. Quality. By keeping everything in the digital realm, there are no unnecessary digital to analogue conversions with HDMI. With technology shifting to digital displays such as plasma and LCD, a lossless digital signal streamed to these devices will ensure you get the crystal-clear picture you've been waiting for. Protection. Uncompressed, high-quality digital signals are a boon for consumers but a concern for content providers. HDCP encrypts provides security for high-definition content being sent digitally between HDMI products paving the way for a truly digital future. HDMI—Your connection to the future—Today.

i.LINK (a.k.a. IEEE 1394)



The promise of DVD-Audio—5.1 channels of up to 96 kHz/24-bit or 2 channels of 192 kHz/24-bit encoding—and Super Audio CD—with a frequency response of up to 100 kHz and a sampling rate of 2.822 MHz—was an elation to music lovers around the world. Next came the crash to earth with the realization that analogue cables (up to six of them no less) would still be needed as transport. It was soon recognized that these sophisticated multi-channel recordings, with quality of sound never realized before, would require a new method of transmission to bring out their true potential. This has arrived with i.LINK connectivity. The simplification and at the same time expansion of your audio experience is made possible with a high-bandwidth, high-resolution transfer of audio signals via a single cable. Even better, the content stays purely digital as the digital to analogue conversions of the past are gone. i.LINK—the new standard for the digital transmission of audio.

TX-NR5000E

THX ULTRA2 7.1 CHANNEL A/V NETWORK RECEIVER

Welcome to the full potential of what a home cinema receiver can be. ONKYO, the company that brought you the world's first 7.1 channel and THX certified receiver now unveils the new definition of flagship receiver. The TX-NR5000E provides technology and design that will impress all, from the audiophile to the casual listener. The THX Ultra2 badge on the front means that this receiver provides a guarantee of the highest quality product available. ONKYO's Premium Digital concept takes on a new state-of-the-art look with the addition of HDMI (High-Definition Multimedia Interface) and i.LINK (a.k.a. IEEE 1394) pure digital inputs and outputs. All the latest encoding formats—THX Surround EX, DTS 96/24, Dolby Pro Logic IIx, and more—here, along with the knowledge that you're ready for the future with upgradable flash memory. ONKYO's exclusive Net-Tune protocol provides streaming music from your computer or Internet radio from the waves of cyberspace. So, for truly breathtaking performance and features from a receiver that truly deserves to be christened as a flagship, read on and find out what true home entertainment is like.

At ONKYO, our mission is simple—the definition and redefinition of what A/V components should sound like. In doing this, over the last 50 years we've built a reputation for the finest sounding products. And when your name means "sound" in Japanese, there's quite a burden to shoulder.

The burden is not sound that can be simply rated in watts or a number on the volume display. The true test is sound that can be felt when you close your eyes and relax—when you listen to the subtlest opera or to thunderous space battles. To describe our unique sound in Japanese, we've coined the term "Kai On Shi-Tsu."

The cumulative result of innovations like WRAT (Wide Range Amplifier Technology), VLSC (Vector Linear Shaping Circuitry) and other sound-enhancing exclusives that only ONKYO can give you. Translated "Kai On Shi-Tsu" means, "Sound Harmony." We're sure you'll agree it's the best sound you've ever heard—and felt.

THX ULTRA2 CERTIFIED



For more than a decade, THX Certification has set the highest standard for home cinema equipment. The TX-NR5000E features the highest level of THX quality assurance with THX Ultra2. Uncompromising sonic reproduction for movies is provided by THX Ultra2 Cinema. Musical enjoyment is brought to previously unmatched levels with THX MusicMode and low frequencies are given a boost through Boundary Gain Compensation (BGC).

HDMI (High-Definition Multimedia Interface)



The TX-NR5000E incorporates the latest in interface technology with the addition of HDMI (High-Definition Multimedia Interface) capability. This high-bandwidth interface conveys not only remarkable amounts of uncompressed digital video but audio as well. Up to 5 Gbps of data, more than twice what's needed for a high-definition movie with surround sound, can be handled with room for future requirements. And all this data is kept in the digital domain as there are no D/A or A/D conversions needed, something that guarantees the highest sound and video quality available.



SILVER BLACK



TX-NR5000E

THE WORLD WILL BE AT ITS FEET





WRAT VIDEO IMAGE ADAPTER TECHNOLOGY

MASTER VOLUME

DVD
THX Cinema
35.0

- DISPLAY
- TAPE 1
- TAPE 2
- TUNER
- PHONO
- CD
- NET AUDIO
- DVD
- VIDEO 1
- VIDEO 2
- VIDEO 3
- VIDEO 4
- VIDEO 5
- VIDEO 6
- VIDEO 7

OPEN

HDMI

AV RECEIVER TX-NR5000E

TX-NR5000E EXCEPTIONAL QUALITY INSIDE—WITH NO EXCEPTIONS



i.LINK (a.k.a. IEEE 1394)

The potential of surround sound DVD-Audio and Super Audio CD had previously been limited by analogue only connections. i.LINK (a.k.a. IEEE 1394) lets you broaden your multi-channel experience while at the same time simplifying it. One wire allows you to transmit high-resolution multi-channel music in the digital rather than the previous analogue domain to get the DVD-Audio and Super Audio CD experience you've been waiting for.

CUTTING EDGE FEATURES

The included RS232 port, Flash Memory, a wide array of digital and analogue inputs and outputs (on the rear), in addition to cutting-edge features such as component video up-conversion of S/Composite Video sources, give you the peace of mind, safe in the knowledge that this receiver is not only ready for the rigours of today's home cinema, but also upgradable for those unknown needs of the future.

ALL THE FORMATS KNOWN TO MAN

All the latest available surround formats transform wherever you are into your own home cinema or concert hall. THX Surround EX, DTS-ES, DTS 96/24, Dolby Digital EX and Dolby Digital Pro Logic IIx envelope you with the latest generation of surround sound encoding for the purest home entertainment experience.

MULTI-ROOM CAPABILITY

Since this is too good to keep in just one room, the TX-NR5000E also gives you the capability to enjoy your movies or music

from separate sources in two additional rooms, giving you sound in three different zones. In addition, with the Speaker A-B mode for 7.1-channels you can set up 7.1-channel systems in two different rooms. When you're finished with room A, switch to room B and continue your movie and music enjoyment in a different surround sound environment.

MAIN FEATURES

- 200 W/Ch (6 Ω , 1 kHz, DIN)
- THX Ultra2 Certified
- THX Surround EX, DTS-ES Discrete/Matrix 6.1, DTS NEO:6, DTS 96/24, Dolby Digital EX, Dolby Pro Logic IIx, Dolby Headphone, Dolby Virtual Surround
- VLSC (Vector Linear Shaping Circuitry)
- Net-Tune Function with MP3/WAV/WMA Decoding
- Ethernet Plug-In Capability
- 2 High-Quality HDMI Audio & Video Inputs and 1 Output
- 2 i.LINK (a.k.a. IEEE 1394) Digital Inputs for DVD-Audio and Super Audio CD
- Speaker A and B Mode for 7.1 Channels
- BTL and Bi-Wiring Connectable for FL/FR with SBR/SBL
- High-Precision 32-Bit Dual DSP Chips
- 192 kHz/24-Bit DACs for All Channels
- 4 Wideband Component Video Inputs (3 RCA/1 BNC) and 2 Outputs (RCA/BNC)
- Composite and S-Video to Component Video Upconversion (NTSC and PAL Compatible)
- Powered Zone 2 and Zone 3
- 5 12 V DC Trigger Outputs and 3 IR Inputs/Outputs
- Bi-Directional RS232 Terminal
- Colour-Coded Heavy Duty Dual Banana Plug Compatible Transparent Speaker Posts
- Colour-Coded 7.1 Multi-Channel Inputs and Pre Outs



Custom High Capacity Low ESR Filter Capacitors to deliver greater power at low frequencies, and provide tremendous continuous power reserves during the most dynamic sound effects and demanding music

Dual High-Purity Extruded Aluminium Heatsinks and an auto-switched cooling fan to keep things cool when the action gets hot

Wolfson 192 kHz/24-Bit D/A Converters simply the best for all channels

Gold-Plated RCA Jacks resist corrosion and provide distortion-free signal transmission

2 Sets of Colour-Coded 7.1-Channel Audio Inputs to connect external 7.1-channel or 5.1-channel decoders for DVD-Audio, Super Audio CD and other future formats

13 Digital Inputs (1 Optical on Front) (7 Optical/6 Coaxial/12 Assignable) to connect any variety of digital sources to the TX-NR5000E's powerful digital processor

Ethernet Port
Net-Tune ready Ethernet port for streaming music files or Internet radio to other client devices

2 i.LINK Ports (a.k.a. IEEE1394) to provide single-cable, high-speed multi-channel audio digital interface

4 Digital Outputs (2 Optical/2 Coaxial/4 Assignable) to make direct digital dubs to other digital devices

Colour-Coded Line Level Pre Outs in the unlikely event you need more power, these let you upgrade all channels via external amplifiers. There's also 2 subwoofer outputs for a more visceral, earth-shaking experience

2 Sets of Colour-Coded Heavy-Duty, Transparent, Dual-Banana-Plug Speaker Terminals for all channels to provide distortion-free signal transfer and accommodate heavy-gauge speaker cable

Composite and S-Video Inputs and Outputs enough to cover all your needs

3 Component Video Inputs and 1 Output for professional-grade, unaltered, wide-bandwidth video-signal transfer

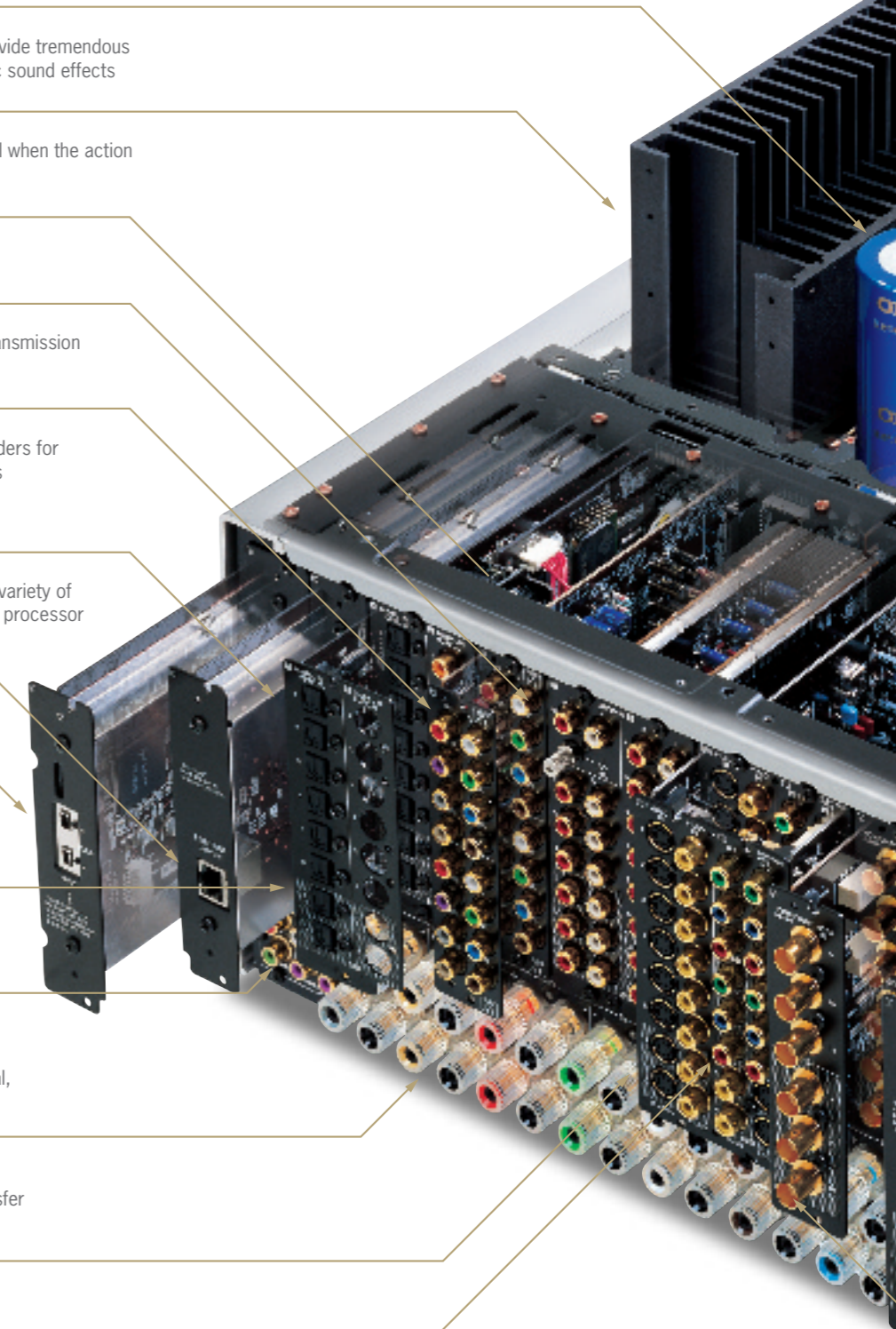



Solid Aluminium Volume Knob
for quality you can feel—ergonomically pleasing and convenient
for those quick in-the-dark level changes

Rec Out Selector (On Front)
to tape one program while watching or listening to another

Massive Shielded-Toroidal Transformer
the kind you find only in the highest-end audio equipment,
to provide copious amounts of pure current

2 High-Bandwidth HDMI Inputs and 1 Output
for the transmission of the highest-quality
compressed or uncompressed digital audio
and video via a single cable

Bi-Directional RS232 Port
to allow download of new programs and
provide an easy interface with touchscreen
controllers from other manufacturers

Dual 32-Bit DSP Chips
for high-grade main and multi-zone decoding

5 12 V DC Trigger Outputs and 3 IR Inputs/Outputs
for multi-zone operation of multiple components

Powerful Transistors
These high-power, high-quality transistors are
ready to amplify your electrical signals for the
highest performance possible

Impeccable Build Quality
a heavy-gauge, reinforced-steel chassis,
rigid aluminium panels and brass stabilizers
to enhance overall chassis stability

Zone 2 Multi-room/Multi-source
(audio and video) to set up additional rooms

Detachable Heavy-Duty IEC Power Cord
to minimize interference from external sources and
increase power stability—detachable for ease of installation

BNC Input and Output
for component video superior to standard pin-jacks
for higher-end home cinema projectors

TX-NR5000E

A UNIQUE MODULAR DESIGN SETS THE NEW BENCHMARK IN AUDIO ENGINEERING

A truly great home cinema receiver will sport a design and features that set it apart from the rest. The TX-NR5000E earns its place at the top with a unique modular design on the rear panel featuring a vast array of the latest digital and analogue inputs and outputs. New additions to Onkyo receivers can be seen in the form of an i.LINK (a.k.a. IEEE 1394) Module for high resolution, multi-channel DVD-Audio and Super Audio CD and an HDMI (High-Definition Multimedia Interface) Module for high-definition video and multi-channel audio digitally sent over a single cable. The Net-Tune Ethernet Module allows you exclusive access to music stored on your PC as well as Internet radio. All manner of digital and analogue inputs and outputs are to be found on the other included modules featuring, optical, coaxial, BNC component connectors, multi-channel, RCA and more. So, for your audio and video enjoyment revel in a design that is unique and a breadth of connectivity that's simply breathtaking.

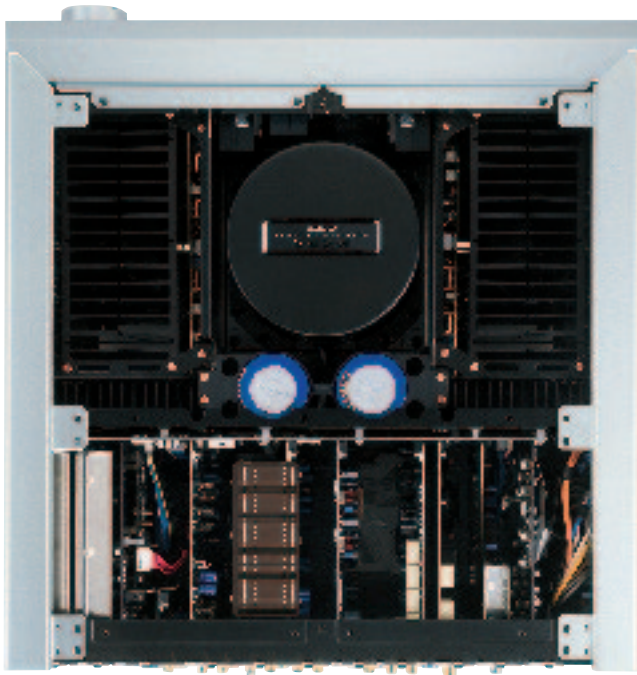

A B C D E F G H I J K L M

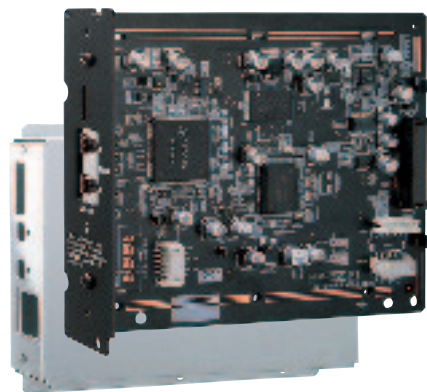

Module A
i.LINK PORT
(a.k.a. IEEE 1394)

High-bandwidth, high-resolution transfer of multi-channel audio signals via a single cable

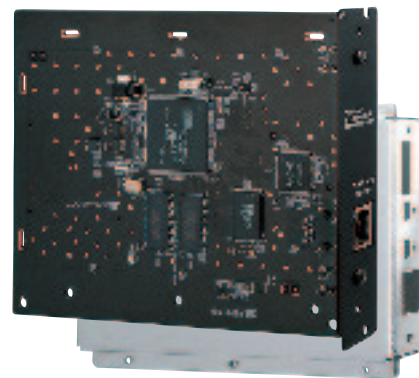

Module B
ETHERNET PORT

Net-Tune ready Ethernet port for streaming music files or Internet radio to other client devices

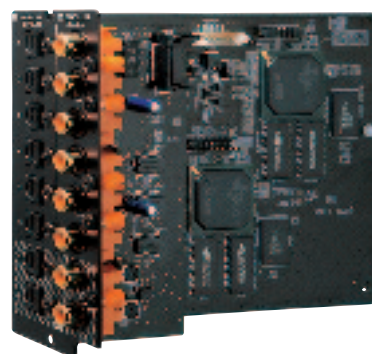

Module C
OPTICAL DIGITAL
INPUTS AND OUTPUTS

Connect your high-speed optical digital components

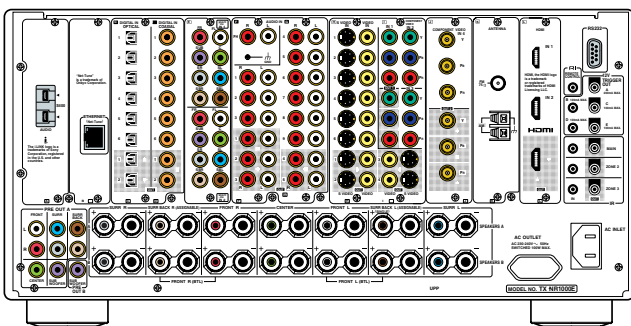

K: Antenna Board

Module D
COAXIAL DIGITAL
INPUTS AND OUTPUTS

Stable digital audio connection for your coaxial components



Module E
MULTI-CHANNEL INPUTS

2 sets of multi-channel inputs for DVD-Audio or Super Audio CD analogue sources

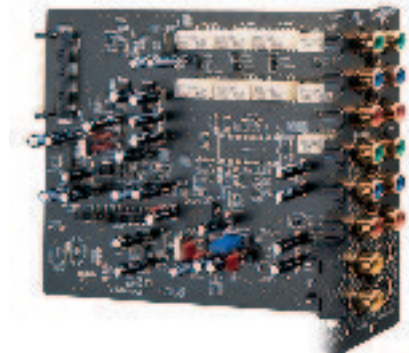

Module I
3 COMPONENT-VIDEO INPUTS AND 1 OUTPUT

For transmission of high-quality HDTV signals and progressive scan DVD Video

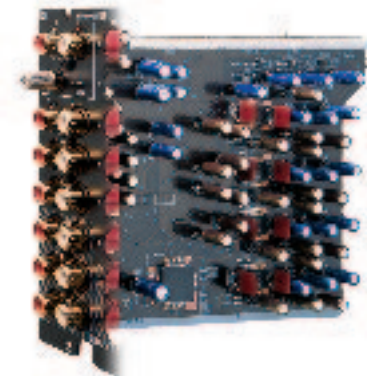

Module F
AUDIO A INPUTS AND OUTPUTS

Analogue sources are not forgotten with an array of inputs and outputs including a phono input for vinyl fans

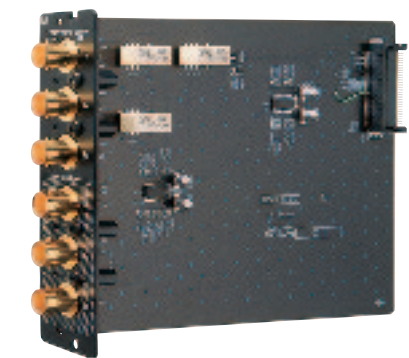

Module J
BNC INPUT AND OUTPUT

Component video input and output BNC superior over standard pin-jacks for home cinema projectors

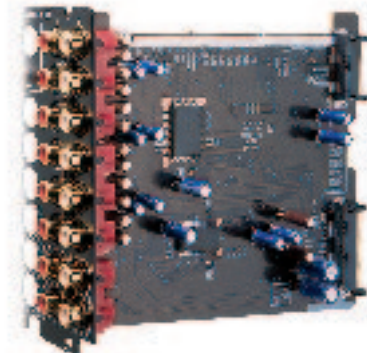

Module G
AUDIO B INPUTS AND OUTPUTS

More analogue can be connected through these inputs and outputs

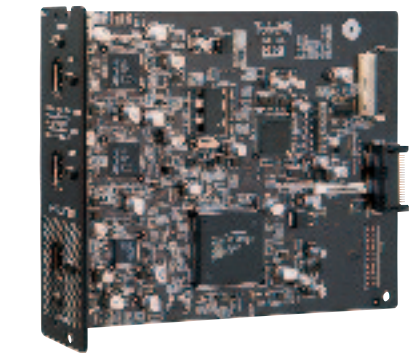

Module L
2 HDMI INPUTS AND 1 OUTPUT

Connect to a compatible TV display or projector for the highest-quality audio and video available

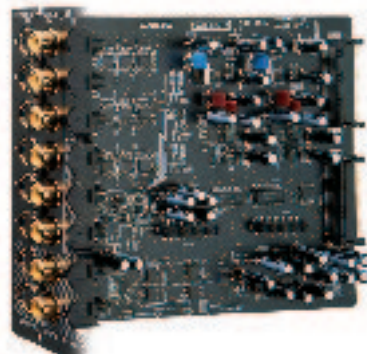

Module H
COMPOSITE & S-VIDEO INPUTS AND OUTPUTS

An abundance of video inputs and outputs to connect those components with composite and S-Video outs

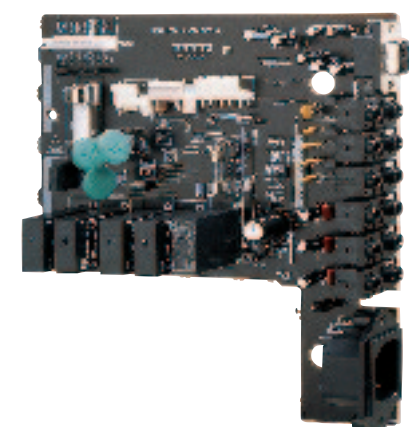

Module M
RS232 PORT,
12 V TRIGGERS AND
IR IN/OUT

External control for multi-room/multi-source capability from a bi-directional RS232 port, multiple 12 V triggers and IR In/Outs

TX-NR5000E

OVER 50 YEARS OF ENGINEERING ACCLAIM IS JUST THE STARTING POINT

ONKYO challenged its engineers to do the seemingly impossible, reinvent the flagship receiver concept—and don't leave anything out. The result is the merging of science and design that represents our greatest technological accomplishment. Now, learn about what makes this the most technologically advanced home cinema centrepiece on the market.

WOLFSON 192 KHZ/24-BIT DACS FOR ALL CHANNELS

If you want the best performance possible from DVD-Audio, Super Audio CD and whatever other high-resolution formats the future has in store, you'll want these ultraprecise converters. Widely recognized as one of the industry's best, these sophisticated digital-to-audio converters from Wolfson process more information faster, deliver an impressive dynamic range, and are virtually jitter-free.



have a stable reference point and not be able to reproduce the signal from the input source accurately. The WRAT design in the TX-NR5000E solves this problem with a component and PCB layout that are carefully designed so that the earth circuit branches form closed loops, and are all connected to a common point. This prevents spurious current flow between different ground points, and effectively eliminates fluctuations in ground potential.

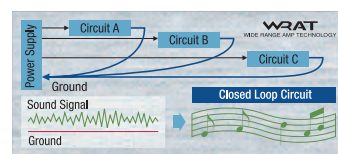
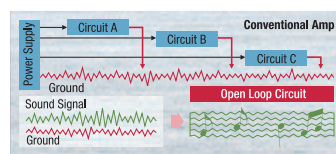

WRAT (Wide Range Amplifier Technology)



This ONKYO exclusive provides a movie cinema-like impact and sound purity that conventional receivers can't match by offering you three distinct advantages:

Low Negative Feedback Design: Most amplifiers return part of the output signal to the amplifier input via a negative feedback (NFB) that has a gain characteristic. If the amount of NFB is large, the amount of counter-electromagnetic force that reaches the amplifier from the speaker will be great, and will disrupt the drive mechanisms and adversely affect its transient response. To avoid this, our engineers reduced the amount of NFB by improving the open-loop frequency response of the amplifier which results in low distortion across the entire frequency range.

High Instantaneous Current Capability (HICC): Typical audio signals are extremely complex, and consist of a wide range of frequencies and amplitude levels. As you would expect from a leader in amplifier design, ONKYO's WRAT amplifiers provide better speaker control capacity and power output than conventional amplifiers.

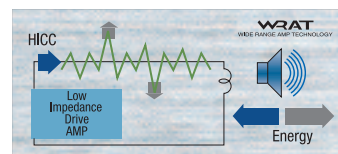
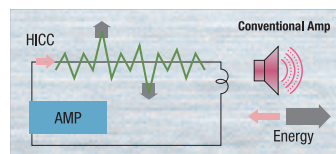

AUDIOPHILE-GRADE PARTS

The massive toroidal power transformer, with secondary windings and independent ground connections

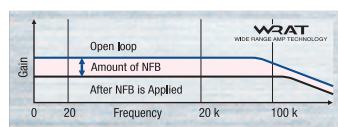
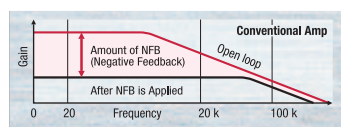

Elimination of Ground-Potential Fluctuations: The signal amplitude at any point in the circuit is the difference in potential between the signal level and its associated ground level. If the ground potential fluctuates, even minutely, due to the presence of electrical noise, the amplifier will not

to isolate each channel from crosstalk and AC-line interference, is the kind you find in high-end audio equipment. Custom high capacity low ESR filter capacitors give you greater power delivery at low frequencies, plus tremendous continuous power reserves during the most dynamic sound effects and music demands. For hi-fi purists, discrete, precision matched output transistors provide faster switching speed, which translates into a wider dynamic range.

OPTIMUM GAIN VOLUME CIRCUITRY

To produce volume at low levels, conventional volume attenuation methods must initially drop a signal close to the noise floor. This often taints the signal with a small amount of noise, which becomes amplified when the signal itself is amplified. Optimum Gain Volume Circuitry solves this problem by adjusting the gain so that less than half the typical amount of attenuation is needed. This ensures that the signal never comes close to the noise floor, and thereby eliminates the possibility of noise contamination that plagues conventional volume-attenuation.

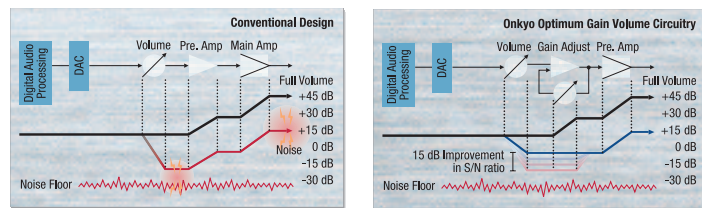

NON-SCALING CONFIGURATION

If you already own a Dolby Digital receiver, you can choose to send the Low Frequency Effect signal (LFE) to the front left and right speakers instead of to the subwoofer. This flexibility is provided by all manufacturers for the benefit of

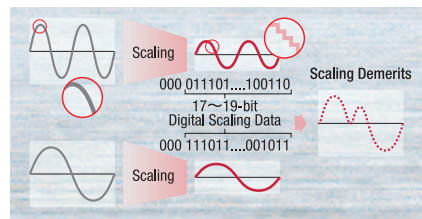

soundtracks, their front speakers can reproduce the LFE signal better than their subwoofer can. Given the ease with which digital signals can be handled, it is perhaps

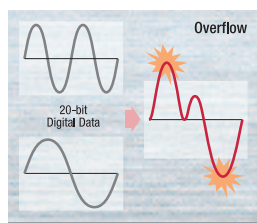

people who do not own a subwoofer, and for users who own high-performance front speakers and feel that with certain music or

unsurprising that nearly all manufacturers of Dolby Digital receivers opt for a shortcut here; they add the 24-bit LFE to the front speaker signals before the LFE are converted to analogue. The price you pay for their convenience is data scaling. To avoid the possibility of overflow (the result of the added digital values exceeding 24 bits), this approach requires that one bit of music or soundtrack data be truncated off each data-word before they are added.

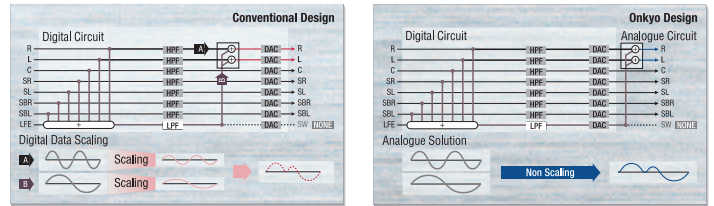

Our philosophy is simply not to mess with the signal (or your music and soundtracks.) No shortcuts. The TX-NR5000E employs a non-scaled circuit design that fully converts all the signals to analogue before the LFE is added to the front channels. This eliminates the need for scaling altogether, and preserves every bit of the original digital data. Though this design is more expensive and difficult to implement, we think it's an ONKYO design difference you'll hear, and a shortcut you'll be glad we didn't take.

PURE AUDIO MODE

When you select the Pure Audio Mode, the video signal is shut down (resulting in a blank screen), and the receiver concentrates on delivering the purest audio possible. This is ideal for those music lovers who want to sit back and enjoy their compact discs, DVD-Audio, Super Audio CDs or multi-channel music discs in an unadulterated listening environment.

TRANSPARENT MULTIWAY BINDING-POST SPEAKER TERMINALS

If you're investing in a receiver of this calibre, you probably have high-performance speakers to match. That's why we included heavy-duty, transparent multiway binding-post speaker terminals for all channels. As well as being aesthetically pleasing to the eyes, they give you a larger "pipe" through which to push the audio signal. The result is a low impedance design approach all the way down to the speaker terminals and a purer signal path and improved sound quality.

TX-NR5000E

INTELLIVOLUME

The output level of each component or source connected to your receiver varies. ONKYO's IntelliVolume automatically "corrects" these variations, so you don't have to adjust the volume every time you change sources.



Aluminium Volume Knob

DIGITAL UPSAMPLING

The TX-NR5000E can take a 48 kHz digital signal and double its sampling frequency to 96 kHz, to glean nearly twice as much signal information—which means greater detail and clarity from all your regular CDs and two-channel analogue sources.



Large Anti-Resonant Brass Stabilizers

ABSOLUTE GROUND PLATE

Something you won't find on other maker's receivers is ONKYO's exclusive Absolute Ground Plate. This provides the ground points for key parts of your receiver in one central location. The result—diminished fluctuations in the electrical potential and elimination of ground hum for more efficient power distribution, reduced noise and crisper sound.

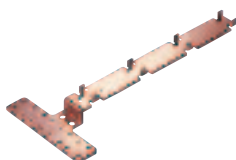

IT WOULD TAKE A METEOR TO WIPE THIS OUT

Evolution of build quality has truly peaked with this ONKYO receiver featuring an anti-resonant, heavy-gauge, reinforced-steel chassis combined with rigid aluminium front, top and side panels to provide greater strength and maximize vibration damping. Large anti-resonant brass stabilizers help keep shelf-borne vibrations from reaching the signal. All these do more than provide long-term elegance—they enhance overall rigidity to dampen unwelcome resonations.

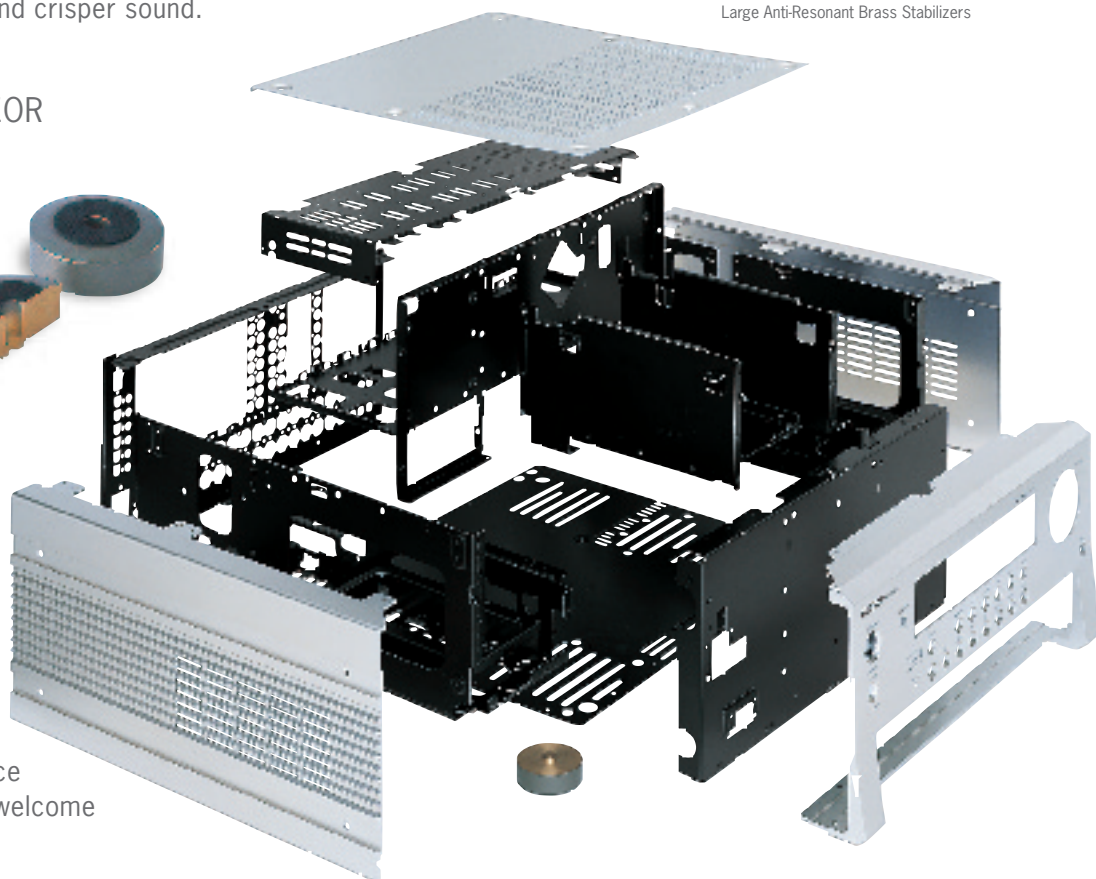

TX-NR5000E WITNESS THE NEXT GENERATION OF USER INTERFACE

While the size and features of the TX-NR5000E may be ominous, the user interface will calm the fears of even the most technophobe of us. Simple and ergonomically designed, the onscreen menus, technologically advanced yet easy-to-use remote control and features may sound intimidating but in reality are more convenient than ever before. The TX-NR5000E—truly the receiver for everyone.

HDMI (High-Definition Multimedia Interface)

HDMI™

The latest in digital interface technology is here and it goes by the name of HDMI (High-Definition Multimedia Interface). Unparalleled amounts of compressed or uncompressed digital audio and video—up to 5 Gbps of data—can be handled with just one high-speed cable.



i.LINK (a.k.a. IEEE 1394)



The reduction of up to six analogue cables to one single digital cable capable of carrying multi-channel audio is here. i.LINK (a.k.a. IEEE 1394) provides the high-bandwidth, high-resolution signal transfer of audio that multi-channel formats like DVD-Audio and Super Audio CD have been waiting for. Even better, content stays in the pure digital realm as there are no unnecessary D/A or A/D conversions performed. Experience the pure digital multi-channel music experience you've been waiting for.



NET-TUNE

NETTUNE™

The TX-NR5000E is part of the only line-up of receivers on the market to feature networking capability. With ONKYO's exclusive Net-Tune protocol, your home cinema receiver makes the transition from home entertainment to home network. Via a 100-Base-TX DHCP enabled broadband router, the musical possibilities are virtually endless. First, free those music files on your computer from the limitation of underperforming speakers. Turn your computer into a

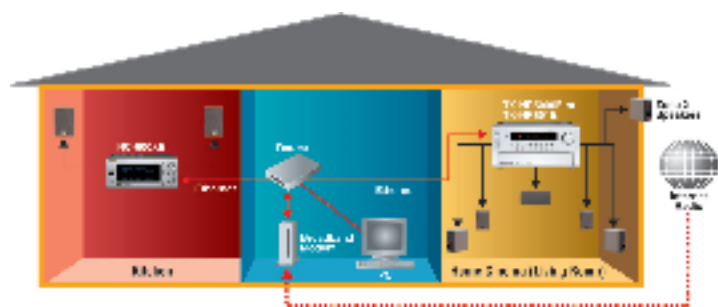

hard disk server with the Net-Tune Central media distribution software and then stream MP3, WAV or WMA files to the TX-NR5000E and through your home cinema speakers. Second, bring a world of music into your home with Internet radio. With a broadband Internet connection, you'll have radio stations from around the world at your fingertips. All of this music potential means nothing if you can't get to it. Using the Net-Tune Central software you can access artists, genres, albums, playlists or individual tracks on your computer or different regions and genres for Internet radio with the on-screen display capability. Don't worry if you don't have the TV on, you can also utilize the large display on the front of the TX-NR5000E. Now you can listen to the kind of music you want, when you want.

SPEAKER A AND B MODE FOR 7.1-CHANNELS

Surround sound doesn't need to be left in one room when you go into another. Take a look at the rear of the TX-NR5000E and you're sure to notice not one but two rows of seven-channel speaker terminals. This allows you to output 7.1-channels from the same source in two separate rooms. Set your receiver for Speaker A Mode and enjoy. Time to move? Set your receiver to Speaker B Mode and the output to Speaker A will be switched to your other room with a 7.1-channel speaker set-up so that you can continue your listening pleasure.

BTL AND BI-WIRING CONNECTABILITY FOR FL/FR WITH SBR/SBL

While a 7.1-channel system is the aim for most home cinema aficionados certain limiting factors—space, significant others, etc.—are the reality today. In other 5.1-channel home cinema systems, the surround back right (SBR) and surround back left (SBL) channel amplifiers are often left unused. Not with Onkyo engineering. Our engineers give you BTL and Bi-Wiring Connectability for FL/FR with SBR/SBL. By switching on this mode, the power of the surround back amps (SBR/SBL) is added to the front left (FL) and front right (FR) speakers for 200 watts of total power for the fronts. Your mother would be proud for not letting anything go to waste.

ONKYO
IMAGINATIVE SIGHT & SOUND

TX-NR5000E

RS232 PORT

The TX-NR5000E is ready to grow with you. Let's face it, this receiver is an investment and you wouldn't want it to become obsolete anytime soon. The bi-directional RS232 port and software upgradable capability of this receiver means that you're ready for those decoding enhancements that are sure to come. But the RS232 isn't just for upgrading, it also provides an even more powerful controller option—seamlessly interfacing with touchscreen controllers from industry leaders such as AMX and Crestron. The control possibilities throughout the house are endless.

ETHERNET CABLE PLUG-IN CAPABILITY

Making ONKYO's lineup of receivers network-ready this Ethernet port located on the back of the TX-NR5000E allows you to bring a world of music into your home. Enjoy unprecedented access to radio stations throughout the world through ONKYO's exclusive Net-Tune protocol in conjunction with a broadband modem hooked up to a router in turn connected to your receiver. Even if you haven't made the upgrade to broadband, Net-Tune Central, [your media distribution software] turns your computer into a hard disc server. Your computer's music files—MP3, WAV and WMA—are streamed through Ethernet so you can experience your music not on the underperforming speakers in your computer but on your home cinema speakers via the TX-NR5000E.

COMPOSITE AND S-VIDEO UPCONVERSION TO COMPONENT VIDEO

Convenience is assured thanks to the ability to run just one cable from your receiver to your high-definition display TV with the upconversion of composite and S-Video signals to component video. Let's be realistic, while the TX-NR5000E is one of the most advanced components

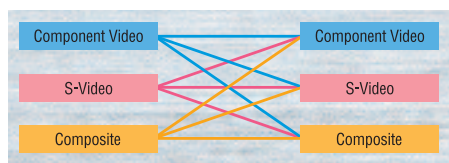

the face of the earth, you're still likely to have some composite or S-Video only

components around the house. Hook-up your video player, CD player, LD player—all your S-Video or composite video out components—to the back of this receiver and each signal will flow to your compatible TV or projector via one component cable.

MULTI-ZONE OPERATION

Enjoy a surround sound movie in one room, while someone else listens to stereo music in another. All without the need for an extra amplifier. We even go one step further with a full set of line-outs for video—so you can set up an additional system in another room. If this is still not enough for you, add an external amplifier for a third zone you can control from the TX-NR5000E.

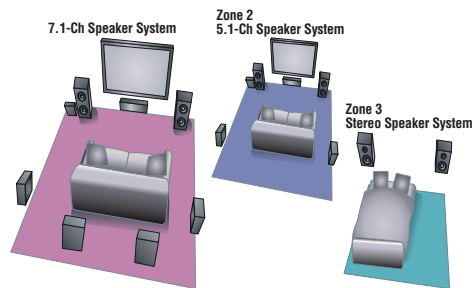

MORE INPUTS AND OUTPUTS THAN YOU'LL KNOW WHAT TO DO WITH

Take a look at the rear panel and you'll soon realize this is no ordinary receiver. In addition to 7.1 multi-channel inputs for analogue DVD-Audio and Super Audio CD, you get thirteen digital inputs, 12 of which are assignable, for connecting a digital TV, including a digital set-top box broadcast satellite (DBS) and other digital based sources, say a DVD, CD and/or LD player, a digital VCR... the list goes on. Four digital outputs allows you to make direct digital dubs to digital devices like a DVD recorder, CD-RW, MiniDisc and DAT decks. If you really want to shake the room, connect two subwoofers. And don't worry, we didn't forget the newest additions. Two high-quality audio & video HDMI (High-Definition Multimedia Interface) inputs and one output are matched with a pair of i.LINK digital inputs. An Ethernet port for Net-Tune finishes off the connectivity roll-call newcomers. Finally—and this is highly unlikely—in the event you need even more power, there are pre-out jacks for each channel to plug in external amplifiers.

4 COMPONENT VIDEO INPUTS AND 2 OUTPUTS

DVD looks wonderful through composite or S-Video connections. But to videophiles, only component video will do. These component video inputs and outputs—not to worry, there's enough to go around—can carry HDTV signals in analogue component format, and handle progressive-scan DVD with ease.

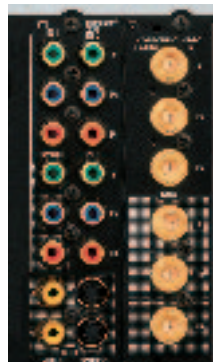

DSP DONE RIGHT

Some manufacturers produce different digital signal processing (DSP) modes by adding variations to the reverberation sound just to increase the total number. What you end up with is a glut of superfluous, seldom-used, gimmicky DSP modes, that are simply on the spec sheet in a feeble attempt to be more competitive on the sales floor. Enter ONKYO DSP. Our engineers, many of whom are trained musicians, dedicated themselves to one audio objective: psycho-acoustically accurate, natural effects that match the music source. Based upon the way humans perceive sound, the TX-NR5000E's proprietary algorithms are far from marketing gimmicks. They provide you with extraordinary tweaking flexibility so you can enhance the way individual recordings sound on your particular system.

SIMPLE ONSCREEN MENUS

Home cinema receivers are loaded with features. But getting to the ones you want and adjusting them can be quite a chore. That's why we designed our NTSC/PAL compatible onscreen displays to be as uncomplicated as possible. A choice of menus in various colours make navigating through functions an aesthetically pleasing experience. A superimpose mode lets you easily see the onscreen display over your TV picture. You can even move the display to different positions on your TV screen. Or remove it completely, by routing the OSD signal to a small monitor. That way you can make adjustments without distracting your audience. You shouldn't need a degree in rocket science to set up your receiver and with the simple, intuitive menus on the TX-NR5000E, you won't need one.



5 12V DC TRIGGER OUTPUTS AND 3 IR INPUTS/OUTPUTS

A full set of 12V triggers and IR inputs/outputs let you have more control than should be legal by law. The IR outputs let you operate the major functions of other RI-compatible components. The 12V triggers start up the projector, let the screen down, or fire-up an additional amp to let you start the show at just the push of one button.



INDIVIDUAL CROSSOVER ADJUSTMENT

Previous receivers have had crossover frequencies fixed at 80 Hz. But the demands and specifications of today's speakers are ever changing. Now with Individual Crossover Adjustment, you can set the crossover from 40–150 Hz in 10 Hz steps (40Hz, 50 Hz, 60 Hz, etc) depending on your speaker's bass playback ability. This lets you more accurately match the performance characteristics of the subwoofer to your front speakers.

LARGE, FLUORESCENT, 35-DOT-MATRIX DISPLAY-WITH 4-MODE DIMMER

Easy to read and use, this dot-matrix display will present all the information you need to see. It's also dimmable with four different modes (Bright/Normal/Low/Off) so you can match the ambience of any room for maximum home cinema enjoyment.

SOLID ALUMINIUM VOLUME KNOB

Quality you can feel from this solid aluminium volume knob. You'll find it ergonomically pleasing and convenient for those quick, in-the-dark level changes.

EASY EVERYDAY USE

Direct-access input buttons on both the remote and front panel mean you don't have to scroll through endless menus just to play your DVDs, CDs, videotapes or other sources. And to take the guesswork out of what format to choose, or what input to use, your TX-NR5000E will automatically switch to the proper coaxial/optical digital or analogue input, detect the audio or surround sound format on your digital or analogue source, and engage it for accurate playback. Best of all, when you select a source, it remembers the surround mode, speaker configuration process for that source—so you can just hit a button, sit back and enjoy the show.



FOR ULTIMATE CONTROL—THE LAST REMOTE YOU'LL EVER NEED



That's a bold statement, but when you can back it up with a technological marvel like this remote control, we're confident you'll agree. From the moment you lay eyes on the remote, you'll realize it's something to behold. And when you hold it, you'll know it's much more than ordinary. Graced with an aluminium front panel and a design perfectly matched to the contours of your hand, you'll find it hard to put down. And when it's in your hand, control is truly yours. The main buttons are logically located in the centre—something that more than a few companies have yet to realize is important for one finger control. And when you press those buttons you'll notice the advantages over soft, "gummy" ones. Smart? Well let's just say this remote has gone to the head of the class with codes from most manufacturers already pre-programmed, and in the unlikely event you need one not included, there's learning capability added so you can do away

with "remote clutter" and use this to control all your compatible components. Not enough? Well we're not stopping there. An LCD screen and scroll wheel let you find the component you wish to control—a DVD player, receiver, video recorder, whatever—with just a spin. And when you want direct access to your TV, buttons at the top let you control the channel and volume without hunting around. With Macros, you can customize the remote to your individual needs by programming a series of operations into a single button. We also took into consideration the importance of entertaining in the dark and not wanting to waste time searching for a button. Backlit with a soft luminescence, low-light operation has never been easier. So now, sit back, pick up your remote and with the push of one button, it can be lights, camera, action—just remember to put it back down occasionally!

DOLBY DIGITAL EX & PRO LOGIC IIx



Dolby Digital EX creates six full-bandwidth output channels from 5.1-channel sources. This is done using a matrix decoder that derives three surround channels from the two in the original recording. For best results, Dolby Digital EX should be used with movie soundtracks recorded with Dolby Digital Surround EX. Dolby Pro Logic IIx processes any

native stereo or 5.1-channel signal into a 6.1- or 7.1-channel output to create a seamless, natural soundfield. You can choose from Movie or Music Modes depending on your source material. There's even a Game Mode that delivers full-impact special effects panned to the surrounds.

DOLBY HEADPHONE



This technology lets you enjoy multichannel sound sources, with thrilling, realistic surround sound over any conventional stereo headset. Dolby Headphone can be applied into virtually any type of product—audio, video, PC or video game which features the Dolby Headphone symbol. Now you can enjoy real surround sound from your headphones without bothering anyone around you.

DOLBY VIRTUAL SPEAKER



With Dolby Virtual Speaker technology, as few as two speakers, placed in front of you in a typical stereo setup, can actually sound like the speakers in a full surround sound home cinema system. This next-generation process reproduces the complex sonic cues necessary to locate where sounds are coming from. It literally convinces your ears that you are surrounded by sonic activity.

DTS & DTS-ES



DTS, like Dolby Digital, is a discrete 5.1-channel system, but one which uses less compression than Dolby Digital. There are two DTS-ES (Extended Surround) formats: DTS-ES Discrete 6.1 and DTS-ES Matrix 6.1. The DTS-ES Discrete 6.1 format is, as the name implies, a 6.1-channel system with a discrete back surround channel, while DTS-ES Matrix 6.1, like Dolby Digital Surround EX, provides a matrix-encoded back surround channel.

DTS NEO:6



For listeners accustomed to multi-channel surround sound, the amount of stereo encoded sound tracks on the market can be disappointing. DTS NEO:6 offers several improvements. Stereo matrix to 6.1 or 5.1: NEO:6 provides up to six full-bandwidth channels of matrix decoding from stereo matrix material. Extended surround: NEO:6 provides optimum decoding of Extended Surround matrix soundtracks, and can also generate a centre surround channel from

5.1 material. Natural Sound Field with Precise Localization: Various sound elements within a channel or channels are steered separately in a way which follows naturally from the original presentation. Music Mode: A Music mode expands stereo non-matrix recordings into the five-or six-channel format, without diminishing the subtlety and the integrity of the original stereo recording.

DTS 96/24



This format offers you the sound quality of the original 96 kHz, 24-bit master in 5.1-channel surround sound for soundtracks on DVDs encoded in DTS 96/24. Also, you won't have to worry about buying a new DVD player. DTS 96/24 can be carried on DVD-Video, or in the video zone of DVD-Audio. This gives you the convenience of making it playable on all DVD players. Benefits include: Sound quality transparent to the original 96/24 master Full backward compatibility with all existing decoders No new player required: Accessible to all DVD players High resolution 96/24 5.1-channel sound with full-quality, full-motion video, for music programs and motion picture soundtracks on DVD-Video. Digital 96/24 output through the S/P-DIF Port. DTS 96/24 allows the use of external, very high quality D/A converters and associated analogue electronics chosen by the user.

THX SURROUND EX THX SURROUND EX

THX Surround EX extends the 5.1-channel format by adding another channel of information between the left and right surround channels. This lets movie sound mixers place sounds behind you, not just to the sides as in a standard cinema. Only THX-certified components provide the following features through THX Surround EX: Redirects bass energy in the surround back channels to the sub-woofer ensuring optimum bass performance. Requires Re-Equalization of the surround back channels to match characteristics of the front and left/right surround channels. Synchronizes the surround back left and surround back right speakers in time and position relative to the listener, providing a seamless surround sound experience. Preserves the original sonic perspective in soundtracks from older films with mono surround channels by automatically re-directing the surround signal to both surround left and surround right rather than to the surround back speakers only. Maintains the same technical standards for surround back channels as for left and right channel surround, eliminating compromise in channel separation, noise, headroom, bandwidth and decoding accuracy.

THX ULTRA2



THX Ultra2 provides you with ultimate eight-channel (7.1) playback of any 5.1 multi-channel program—enjoy reference standard playback of music as well as movies. In the new THX Ultra2 Cinema mode or THX MusicMode, all program material with 5.1-channel or more is auto-detected and proprietary processing applied that blends the directional and ambient surround information prior to replay through four surround speakers—two at the side and two at the back. Ultra2 receivers and controllers also feature switchable Boundary Gain Compensation (BGC) to alleviate “boomy” bass performance that can occur with near-wall listening positions.

A-FORM LISTENING MODE MEMORY

Our exclusive advanced memory system not only senses the signal format—DTS, Dolby Digital, or stereo, for example—but also, unlike any other receiver, switches to the listening modes you pre-assigned for that source. So you can just hit a button, sit back and enjoy your movies and music.



Custom High Capacity Low ESR Filter Capacitor's Give You Greater Power

DV-SP1000E

THX ULTRA CERTIFIED UNIVERSAL DVD-AUDIO & SACD PLAYER

Many say that the receiver is the heart of your home cinema but it still needs movies and music pumped to it and there's no better delivery mechanism than the rugged DV-SP1000E. One look at this DVD player and you'll know it's built to last. Vibrations are kept to a minimum with a sturdy chassis and loading mechanism specifically designed for the smoothest delivery of your movies and music. Universal takes on an entirely new dimension with the DV-SP1000E not only providing you with DVD Audio-Video, and Super Audio CD playback but also analogue and pure digital reproduction with the inclusion of HDMI (High-Definition Multimedia Interface) and i.LINK (a. k. a. IEEE 1394) connections for high-quality movies and multi-channel music. ONKYO's VLSC (Vector Linear Shaping Circuitry) and FlexScale from Oplus video scaling of 480i to 480p/720p or 1080i guarantee superlative audio and video playback that other manufacturers can't match. You'll find all of this contained within a THX Ultra certified component that's ready to deliver a sensational standard of audio and video to your home cinema.

Our 50 years plus of experience in Imaginative Sight & Sound allows you to experience pure listening and viewing pleasure. ONKYO not only provides you with the highest picture quality available through Veridic Progressive Scan and a 216 MHz/14-bit video DAC from Analog Devices to bring out all the richness of your video, but also audiophile quality sound from 192 kHz/24-bit audio D/A converters and ONKYO exclusives like Dual Direct Digital Path technology and VLSC (Vector Linear Shaping Circuitry) for an all-enveloping oratory experience that only ONKYO can bring you.

The inclusion of both DVD-Audio and Super Audio CD (SA-CD) decoding in addition to a design ready to support all of the major disc formats today is welcome news to all who are weary of the progressively confusing “format wars.” All of this adds up to a truly astounding sight & sound experience.

UNIVERSAL PLAYABILITY

With the DV-SP1000E, you'll not only find yourself enjoying the highest quality video from your DVD collection but also pristine audio playback from reference quality DVD-Audio and Super Audio CD, as well as almost any other 12 cm disc on the market. DVD-Audio and Super Audio CD are nothing less than the new world standards for super-high fidelity sound. DVD-Audio allows data-loss reproduction of either 192 kHz/24-bit 2-channel stereo or 96 kHz/24-bit 6-channel surround sound. Super Audio CD provides stereo or multi-channel audio playback with a frequency response of up to 100 kHz and a sampling rate of 2.822 MHz to give pure sonic clarity. CD-R/ DVD-R (write-once) and CD-RW/DVD-RWs (rewritable) with your favorite music, MP3s or picture coded files provide hours of uninterrupted performance for your home cinema system.

HDMI (High-Definition Multimedia Interface)



The DV-SP1000E incorporates the latest in interface technology with the inclusion of HDMI (High-Definition Multimedia Interface) capability. This high-bandwidth interface supports not only remarkable amounts of uncompressed



ONKYO

www.eu.onkyo.com

Download from www.Somanuals.com. All Manuals Search And Download.

DV-SP1000E

TOGETHER WITH THE TX-NR5000E, AN UNPARALLELED ALLIANCE OF AUDIO-VISUAL PERFECTION





THX
CERTIFIED

TRACK V.OFF
3 5 1:47
DUAL DVD-MEMO

VERIDIC PROGRESSIVE SCAN

ONKYO
DVD
VIDEO

DISPLAY
STOP
SKIP
SKIP

SUPER AUDIO CD & DVD AUDIO/VIDEO PLAYER DV-SP1000E

DUAL DIRECT DIGITAL PATH

digital video but audio as well. Up to 5 Gbps of data, more than twice what's needed for a high-definition movie with surround sound, can be handled with room for any future requirements. All this data is kept in the digital domain as there are no D/A or A/D conversions needed, all of which ensures the highest sound and video quality available.

i.LINK (a.k.a. IEEE 1394)



The allure of surround sound DVD-Audio and Super Audio CD had previously been limited by analogue only connections. i.LINK (a. k. a. IEEE 1394) lets you broaden your multi-channel experience while at the same time simplifying it. One wire allows you to transmit high-resolution multi-channel music in the digital rather than the previous analogue domain to get the DVD-Audio and Super Audio CD experience you've been waiting for.

OPLUS FLEXSCALE VIDEO SCALING CAPABILITY



Progressive scan players can at most, output an NTSC 480p signal or PAL 576p signal to compatible TVs or projectors. The DV-SP1000E will upscale conventional DVD (NTSC 480i or PAL 576i) to 480p/576p/720p or 1080i via the built-in FlexScale video scaler from Oplus. The result is a crystal clear, ultra-sharp image on HDTV compliant playback devices that will take your viewing experience to previously unattainable levels.

THX-ULTRA CERTIFIED



Only those players capable of realizing the highest potential of DVD technology can bear the THX certification badge. It means the DV-SP1000E meets the exceedingly high THX Ltd. performance standards for not only the sound and picture, but also for user convenience, quality and long-term reliability.

VLSC (Vector Linear Shaping Circuitry)



Conventional D/A conversion methods reduce digital pulse noise at the conversion stage but can't remove it completely. VLSC (Vector Linear Shaping Circuitry) employs a unique D/A conversion circuit to overcome this problem. Data is converted between the sampling points and these discrete sampling points are joined with analogue vectors in real-time to produce a smooth output wave form. The result—a virtually noiseless, smooth analogue signal based on the digital source.

MAIN FEATURES

- THX Ultra Certified
- DTS & Dolby Digital Decoders Built-in
- Plays DVD-Audio & Video, DVD-Rs*, DVD-RWs*, Super Audio CDs, MP3 CDs, CD-Rs, CD-RWs, Video CDs, Audio CDs and Picture CDs
- State-of-the-Art 216 MHz/14-Bit Analog Devices NSV Video DAC
- Wolfson 192 kHz/24-Bit Audio DACs
- Dual Direct Digital Path
- Optical & Coaxial Digital Outputs for DTS, Dolby Digital and PCM
- High Quality HDMI Audio & Video Output
- 2 i.LINK (a. k. a. IEEE 1394) Digital Outputs
- 2 Component-Video (RCA/BNC), S-Video & Composite Outputs
- 12 V Trigger In and IR In/Out
- Bi-Directional RS232 Terminal
- Parallel Outputs-All Outputs Active
- Rigid Aluminium Front/Side Panel with Brass Stabilizers
- PAL and NTSC Veridic Progressive Scan
- On-Screen Display
- Elegant Aluminium-Faced Backlit Remote Control

* Discs that have not been properly finalized may only be partially playable or not playable at all.



**DV-SP1000E
INSIDE ONE OF THE MOST ADVANCED
DVD PLAYERS IN THE WORLD**

From the first glance, you're sure to find the DV-SP1000E a truly breathtaking home cinema component. It doesn't just stop there as you are insatiably drawn to find out more about this marvel. The rear panel boasts an array of the most advanced digital and analogue inputs and outputs. Inside you'll find the highest quality parts and logically designed boards to bring out the most pristine experience of audio and video quality you have ever encountered. However you compare them, other DVD players don't even come close.



Bi-Directional RS232 Port
to download new formats and provide easy interface with touchscreen controllers from other manufacturers

2 i.LINK Ports (a.k.a. IEEE1394)
to provide single-cable, high-speed multi-channel digital interface

High-Bandwidth HDMI Output
for the transmission of the highest-quality compressed or uncompressed digital audio and video via a single cable

S-Video/Composite Video input
for video connectivity

2 S-Video/2 Composite Video Outputs
for better picture quality from high-resolution video sources

i.LINK (a.k.a. IEEE 1394) BOARD

Providing you 2 ports for pure digital multi-channel audio for DVD-Audio and Super Audio CD from a single cable

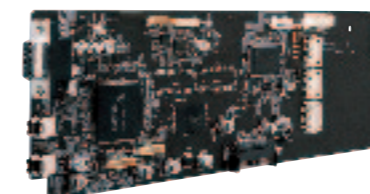

HDMI (High-Definition Multimedia Interface)

An HDMI output provides you with the highest bandwidth audio and video from a single cable

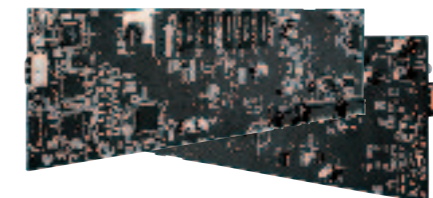

VIDEO OUT BOARD

Holds the high quality 216 MHz/14-bit NSV video DAC from Analog Devices for crystal-clear video

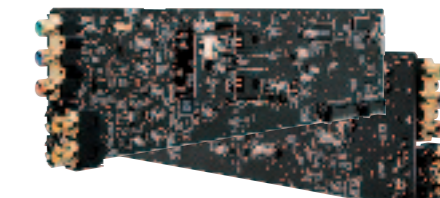

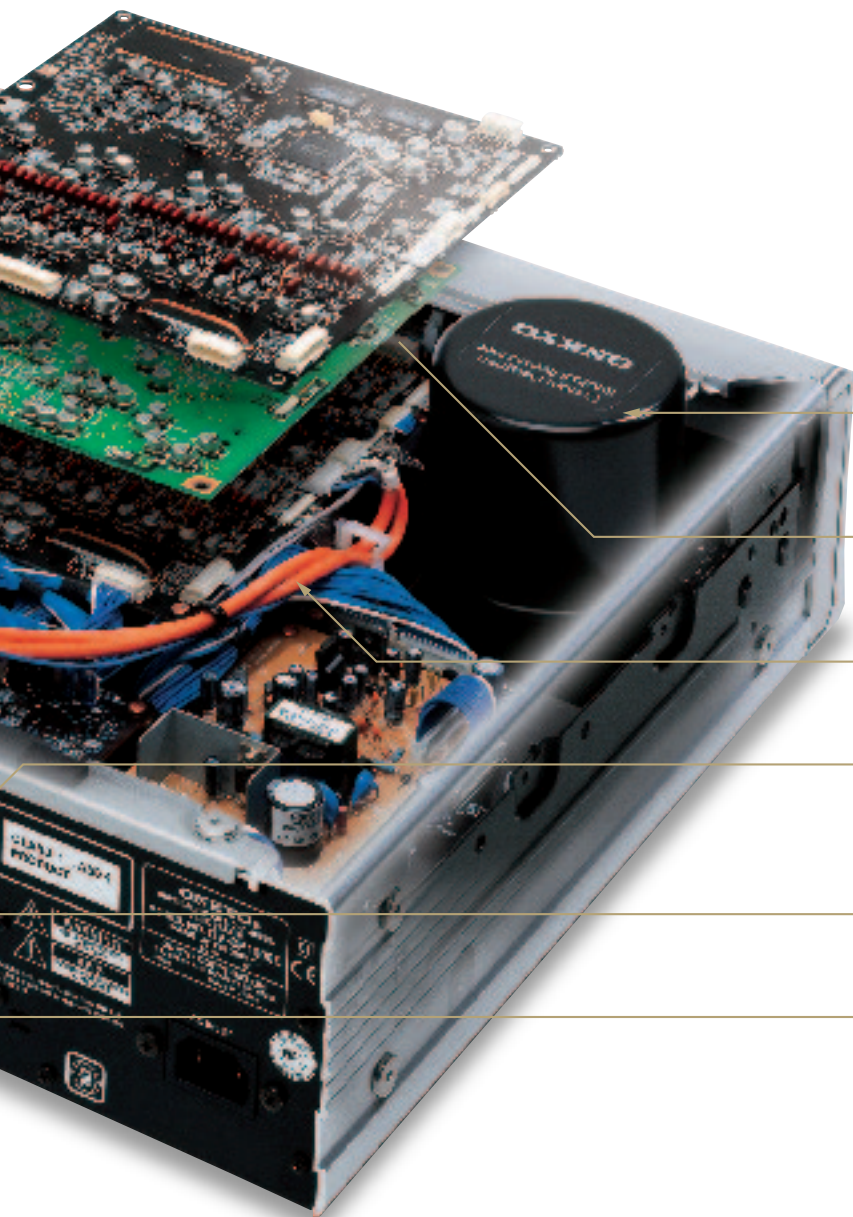

High-Power Transformer

This high-power transformer is part of the reason—the DV-SP1000E, one of the heaviest players in its class

Heavy-Duty DVD Mechanism

to keep vibrations to an absolute minimum for premium audio and video delivery

Dual Direct Digital Path

for heavy shielding of delicate audio signals

Colour-Coded Multi-channel Analogue Outputs

to connect external decoders for DVD-Audio and Super Audio CD

4 Digital Outputs (2 Optical & 2 Coaxial)

for direct digital connection to other digital devices

2 Component Video Outputs (RCA/BNC)

for professional-grade, unaltered, wide-bandwidth video-signal transfer

DIGITAL AND ANALOGUE AUDIO BOARD

Analogue still sounds marvellous with this high-precision board

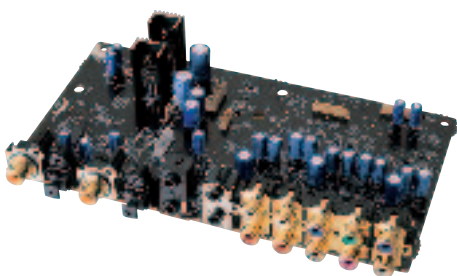

ANALOGUE AUDIO DRIVER BOARD

High-precision integrated circuits handle such essential tasks as digital-to-analogue conversions with ease

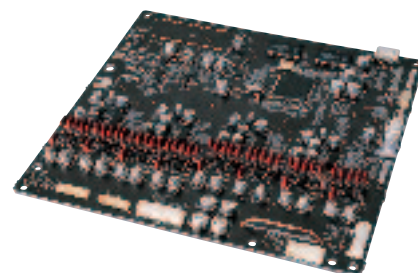

DVD CORE BOARD

Controls the DVD mechanism, display, D/A conversions and more to provide you with the entertainment experience you deserve

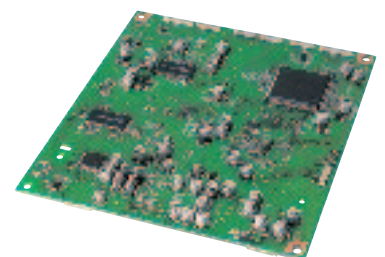

DV-SP1000E PRISTINE REPRODUCTION OF AUDIO AND VIDEO DOESN'T JUST HAPPEN BY CHANCE

Our primary objective in the creation of the DV-SP1000E was to provide you with the latest digital technologies, the highest quality parts and build. You might think we were overreaching. Once you experience how much further your entertainment system goes, you'll be thanking our engineers.

THX ULTRA CERTIFIED



To earn the THX Ultra badge of approval, the DV-SP1000E underwent a demanding series of quality and performance tests to ensure you'll have all the essential elements needed for a flawless transformation of the cinema experience to your home.

OPLUS FLEXSCALE VIDEO SCALING CAPABILITY

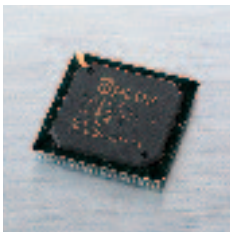

While HD-DVD with a native resolution of over NTSC 480p or PAL 576p is still on the drawing board, you can experience HD level 720p and 1080i via FlexScale video scaling capability from Oplus. Built-in to the DV-SP1000E and so eliminating the need for costly external scalers,

FlexScale takes NTSC 480i or PAL 576i DVDs beyond normal progressive scan players and into the HD domain by enabling 720p or 1080i output through the HDMI (High-Definition Multimedia Interface) out on the rear.



VLSC (Vector Linear Shaping Circuitry)



Conventional D/A conversion methods reduce digital pulse noise at the conversion stage but can't remove it completely. VLSC (Vector Linear Shaping Circuitry) employs a unique D/A conversion circuit to overcome this problem. Data is converted between sampling points and these discrete points are joined

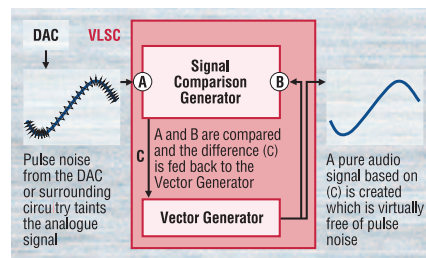

with analogue vectors in real-time to produce a smooth output wave form. The result—a virtually noiseless, smooth analogue signal based on the digital source.

EXCLUSIVE DUAL DIRECT DIGITAL PATH

Unlike other DVD players that use inexpensive PC-board copper traces to transfer the digital audio signal, the DV-SP1000E employs dual high-purity, heavy gauge, shielded cables to directly output digital or PCM bitstreams straight from the disc to the back panel. This protects the audio signal against potential noise from nearby microprocessors and power supplies. So if you use the optical or coaxial digital output to send multi-channel Dolby Digital, DTS and more to your compatible receiver, you're starting off with the cleanest possible signal.

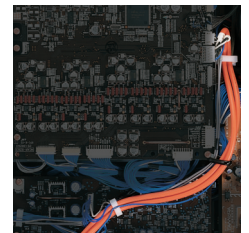

ANALOG DEVICES 216 MHZ/14-BIT NSV VIDEO DAC

A crucial factor in achieving clear, pristine digital video playback is the video D/A converter in your DVD player. The state-of-the-art 216 MHz/14-bit video DAC from Analog Devices featured in the DV-SP1000E gives you the finest artifact-free picture available. Features such as 4x oversampling and Noise Shaped Video (NSV) dramatically reduce noise interference to the video signal, so you can enjoy even the most subtle of nuances in your favorite movies.



STATE OF THE ART WOLFSON 192 KHZ/24-BIT DACS

Performing at full 192 kHz/24-bit levels of resolution, these DACs from premium chip maker Wolfson, deliver industry-standard setting audio performance that is second to none. The advantages of the Wolfson chip architecture include ideal differential linearity, no distortion mechanisms due to resistor matching errors, no linearity drift over time and temperature, and a high tolerance to clock jitter for the best performance possible from DVD-Audio, Super Audio CD and whatever other high-resolution formats the future has in store.



PASSES PLUGE SIGNALS

Even small black-level errors will subtly deteriorate picture quality. But if the correct setting is achieved, there will be no adverse effects while viewing. That's why the DV-SP1000E can pass PLUGE (Picture Line Up Generation Equipment) signals, a test pattern that makes it easy to accurately calibrate the black-level of a monitor to the DVD player.

2 GOLD-PLATED S-VIDEO OUTPUTS

To carry luminance and colour information in separate signal paths to TVs and monitors without component video inputs.



2 GOLD-PLATED COMPONENT-VIDEO (BNC/RCA) OUTPUTS

Reveal the full potential of DVDs by providing a high quality connection to compatible TVs, projectors and monitors. The "colour-difference" outputs (Y, PB, PR) provide three signals from which extremely clean red, green and blue colour information can be derived and sent along to a picture tube, thereby eliminating the usual NTSC and PAL artifacts, including dot crawl and moiré (wavelike or watered appearance),



for stunning colour fidelity, a more film-like, three-dimensional image and absolutely no discernible video noise.

2 GOLD-PLATED COAXIAL DIGITAL AUDIO OUTPUTS

For simple, single-cable hook-up to a receiver, processor or amplifier. They offer software selection for maximum convenience when switching between DVD, Video CD and CD playback.

2 OPTICAL DIGITAL OUTPUTS

For added versatility and high-quality, direct digital-to-digital connection to other digital components such as CD-Recorders, MDs, and DAT Decks.



DUAL LASER PICKUP

DVDs, Video CDs, CDs, CD-R/RWs, DVD-R/RWs, DVD-Audio, Super Audio CD and more—the mechanical simplicity avoids potential switching and misalignment problems associated with other players, and ensures long-life and optimal tracking.

HIGH-POWER TRANSFORMER

This high-power transformer is part of the reason the DV-SP1000E is one of the heaviest players in its class. It's ready to provide plenty of power reserve for today's demanding multi-channel digital sources, and is designed for efficient operation, even under high temperatures. Naturally it's also shielded to minimize hum and flux leakage.



DV-SP1000E

OVERSIZED ELECTROLYTIC CAPACITORS

Greater power delivery at low frequencies and abundant continuous power reserves during most dynamic sound effects and musical demand are no problem for these capacitors.



THICK BUS BARS

Diminish fluctuations in the electrical potential and eliminate ground hum for more efficient power distribution, reduced noise, and crisper sound.



THICK, BRUSHED ALUMINIUM FRONT PANEL

Provides long-term elegance—the thick sheet of aircraft-grade aluminium resists scratching, is easy to wipe clean, and enhances overall chassis rigidity.

IT WOULD TAKE A METEOR TO WIPE THIS OUT

Evolution of build quality has truly peaked with this ONKYO DVD player featuring an anti-resonant, heavy-gauge, reinforced-steel chassis combined with rigid aluminium front, top and side panels to provide greater strength and maximize vibration damping. Large anti-resonant brass stabilizers help keep shelf-borne vibration from reaching the signal. All these do more than provide long-term elegance—they enhance overall rigidity to dampen unwelcome resonations.

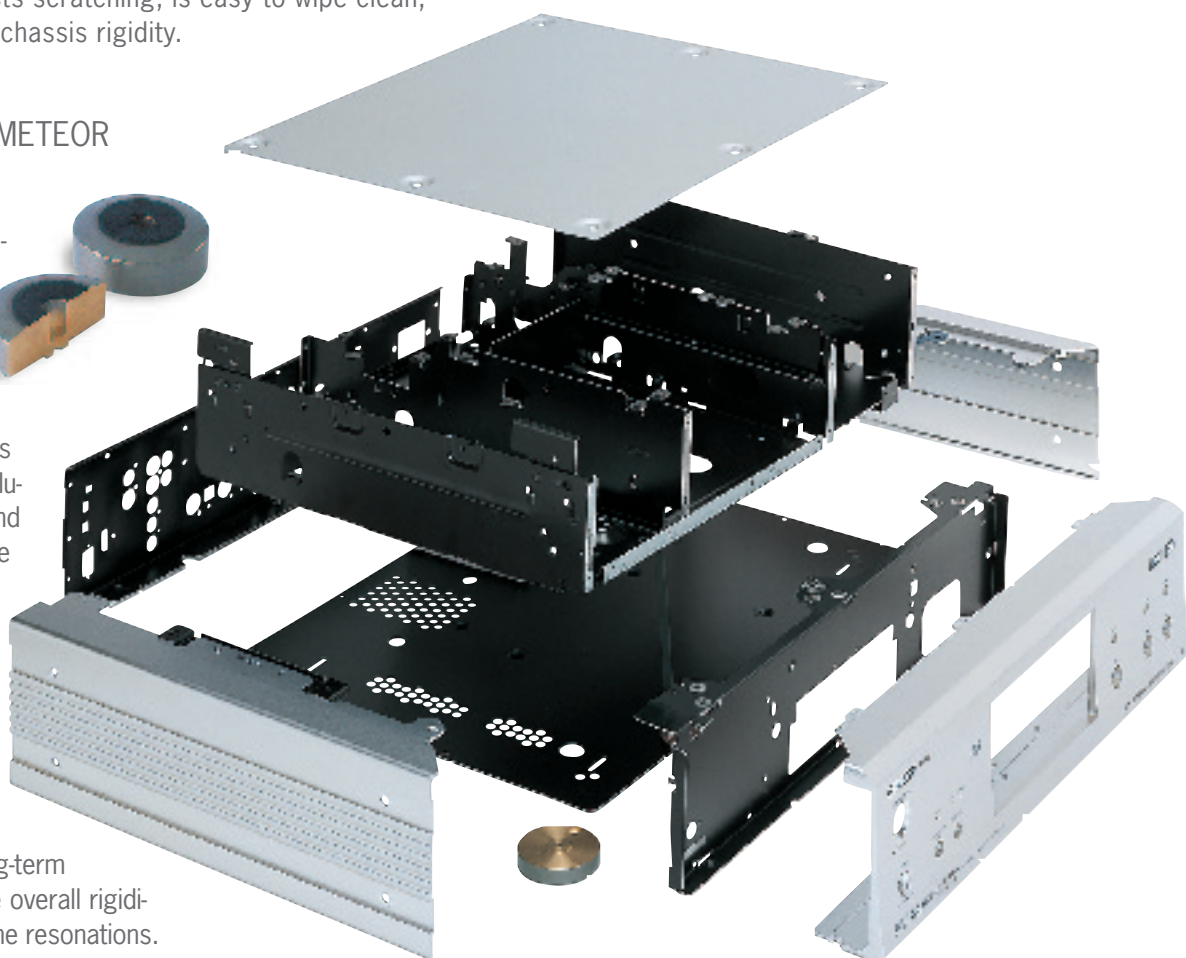

DV-SP1000E

DELIVERY OF SOUND AND VISION TO LEAVE THE OTHERS BEHIND

We believe that truly user-friendly products are those components that provide satisfaction in ownership for many years to come, not merely for a short honeymoon period. Read on to allay any doubts about the DV-SP1000E.

DVD-AUDIO



DVD-Audio is nothing less than the world standard for super-high fidelity sound. With approximately seven times the storage capacity of CDs and data-loss-free reproduction of 192 kHz/24-bit 2-channel stereo or 96 kHz/24-bit 6-channel surround sound, DVD-Audio provides ultra-high performance stereo sound and multiple-channel sound that realistically captures the acoustics of the finest music on the market.

SUPER AUDIO CD (SA-CD)



Starting a revolution in the way music is digitally recorded and played back, Super Audio CD (SA-CD) incorporates Direct Stream Digital (DSD) technology for a frequency response of over 100 kHz and a dynamic range over 120 dB. Hybrid SA-CDs, containing both a normal CD layer and a SA-CD layer, or SA-CD only discs can provide a multi-channel or stereo mix for the next step in the evolution of pristine sound.

HDMI OUTPUT



The latest in digital interface technology is here and it goes by the name of HDMI (High-Definition Multimedia Interface). The DV-SP1000E features an output for unparalleled amounts of compressed or uncompressed digital audio and video—up to 5 Gbps of data—can be handled with just one high-speed cable.

I.LINK (a.k.a. IEEE 1394)



The reduction of up to six analogue cables to one single digital cable capable of carrying multi-channel audio is here. i.LINK (a.k.a. IEEE 1394) provides the high-bandwidth, high-resolution signal transfer of audio that multi-channel formats like DVD-Audio and Super Audio CD have been waiting for. Even better, content stays in the pure digital realm as there are no unnecessary D/A or A/D conversions performed. Experience the pure digital multi-channel music experience you've been waiting for.

VERIDIC PROGRESSIVE SCAN NTSC/PAL

Most DVDs are “progressive”—meaning they produce video in complete frames. But to be compatible with all TVs, the DVD signal must be interlaced—a method where the picture is split into two fields and then “interlaced” back together to look like one. ONKYO's exclusive Veridic Progressive Scan for NTSC and PAL systems, retrieves the original progressive signal, and on such compatible displays as HDTV, Plasma or digital TV and high-end projectors, “paints” all the visible lines on the screen in a single pass—so you'll enjoy a genuine, scan-line free image, with spectacularly clear colour, no motion artifacts, and details so sharp they'll seem as if they're etched onto the screen.

BI-DIRECTIONAL RS232 TERMINAL

Go all out with this bi-directional RS232 terminal on the back of the DV-SP1000E. Control is enhanced with connectability to elaborate home-automation controllers from Crestron, AMX and others. Worries about future technologies are alleviated with software upgradability via this bi-directional RS232 terminal ensuring this is one DVD player that won't become obsolete.



VIDEO CIRCUIT ON/OFF CONTROL

For the best audio quality possible, you can turn off the video circuitry when using the DV-SP1000E as an audio only player. This eliminates the possibility of interference between the player's video and audio circuitry giving you a purer signal for your listening pleasure.

12 V TRIGGER INPUT AND IR INPUT/OUTPUT

Bring more control to your remote. An assignable 12 V trigger to switch on another amplifier or video screen. An IR output lets you use your receiver's remote to operate the major functions of other RI-compatible components! Start the entire show at just the touch of one button on your remote.



ONKYO
IMAGINATIVE SIGHT & SOUND



FOR ULTIMATE CONTROL—THE LAST REMOTE YOU'LL EVER NEED

That's a bold statement, but when you can back it up with a technological marvel like this remote control, we're confident you'll agree. From the moment you lay eyes on the remote, you'll realize it's something to behold. And when you hold it, you'll know it's much more than ordinary. Graced with an aluminium front panel and a design perfectly matched to the contours of your hand, you'll find it hard to put down. And when it's in your hand, control is truly yours. The main buttons are logically located in the centre—something more than a few companies have yet to realize—for one finger control. And when you press those buttons you'll notice the advantages over soft, "gummy" ones. Smart? Well let's just say this remote has gone to the head of the class with codes from most manufacturers already preprogrammed, and in the unlikely event you need one not included, there's learning capability added so you can do away with "remote clutter" and use this to control all your compatible components. Not enough? Well we're not stopping there. When you want direct access to your TV, buttons at the top let you control the channel and volume without a search. With Macros, you can customize the remote to your individual needs by programming a series of operations into a single button. We also took into consideration the importance of entertaining in the dark and not wanting to waste time searching for a button. Backlit with a soft luminescence, low-light operation has never been easier. So now, sit back, pick up your remote and with the push of one button, it can be lights, camera, action—just remember to put it back down occasionally!

Due to a policy of continuous product improvement, ONKYO reserves the right to change specifications and appearance without notice.

"THX" is a trademark or registered trademarks of THX Ltd. "Dolby", "Pro Logic" and the double-D symbol are trademarks of Dolby Laboratories.

"THX Surround EX-Dolby Digital Surround EX" is a joint development of Dolby Laboratories and THX Ltd. and is a trademark of Dolby.

"DTS", "DTS-ES Extended Surround", "DTS 96/24" and "NEO:6" are trademarks of Digital Theater Systems, Inc. "HDMI" is a trademark or registered trademark of HDMI Licensing, LLC.

"i.LINK" is a trademark of Sony Corporation. "FlexScale" is a trademark of Oplus Technologies Ltd. "Net-Tune" and "VLSC" are trademarks of ONKYO Corporation.

All other trademarks and registered trademarks are the property of their respective holders.

PRODUCT SPECIFICATIONS

Features

TX-NR5000E – THX Ultra2 Network A/V Receiver

AMPLIFIER DESIGN	
Identical Full-Bandwidth Channels	7
Reduced NFB (Negative Feedback) Design	•
WRAT (Wide Range Amplifier Technology)	•
VLSC (Vector Linear Shaping Circuitry)	•
Non-Scaling Configuration	•
BTL (Bridge Tie Load)	•
192 kHz/24-Bit DACs	All Channels
Absolute Ground Plate	•
High Current Low Impedance Drive	•
All Discrete Output Stage Amplifiers	•
Optimum Gain Volume Circuitry	• (Linear)
Digital Upsampling	•
HOME CINEMA FEATURES	
THX® Surround EX™ and THX® Ultra2 Certified	•
Extended Frequency Response (+1 dB, -3 dB)	5 Hz – 100 kHz
DTS®, DTS®-ES™ Discrete/Matrix 6.1, DTS 96/24 and DTS® NEO:6	•
Dolby® Digital, Dolby® Digital EX™, Dolby® Pro Logic™ IIx	•
Dolby® Headphone and Dolby® Virtual Speaker	•
A-Form Listening Mode Memory	•
Composite and S-Video to Component Video Upconversion	•
Multichannel Input (7.1 Ch. Input)	2
Digital Signal Processing Modes	39
Late Night Mode	•
Colour-Coded Speaker Terminals	•
On-Screen Display	•
Adjustable Digital Delay	•
Crossover Adjustment	40 – 150 Hz, 10 Hz Steps
NETWORK FEATURES	
Net-Tune (Ethernet Port)	1
Number of Presets (Internet Radio)	30
MP3/WAV/WMA Decoding	•
INPUTS/OUTPUTS	
i.LINK (IEEE 1394) Inputs	2
HDMI Inputs/Outputs	2/1
Audio Inputs/Outputs	9/5
Video Inputs/Outputs (Composite)	7 (1 Front)/4
S-Video Inputs/Outputs	7 (1 Front)/4
HDTV-Ready Component Video Inputs/Outputs	4 (3 RCA/1 BNC)/2 (1 RCA/1 BNC)
Digital Inputs	7 Optical (1 Front)/6 Coaxial
Digital Outputs	2 Optical/2 Coaxial
RS232 Control Port	1
IR In/Out (Main/Zone 2/Zone 3)	3/3
12V Trigger Outputs	5
Phono Input	1
Pre Out A (Front L/R, Centre, Surround L/R, Surround Back L/R and Subwoofer)	•
Pre Out B (Subwoofer)	•
OTHER FEATURES	
Display Dimmer	4-Mode
Pure Audio Mode	•
Dual Banana Plug Compatible Speaker Terminals	7 Ch. x 2 Sets
Sleep Timer (90 minutes; 10-min steps)	•
Headphone Jack	•
Zone 2 (Multisource) Line Out	•
Powered Zone 2 and Powered Zone 3	(Audio/Video)
TUNER FEATURES	
Number of Presets (FM/AM)	40
RDS	RT/PTY/IP
CONTROL	
RI-Compatible Remote Control	Learning/Scroll/Backlit/LCD
Macro Function	•
Absolute/Relative Volume Display	•
IntelliVolume	•

Specifications

AMPLIFIER SECTION	
Power Output** (6 Ω, 1 kHz, DIN)	
– Front L/R	200 W + 200 W
– Centre	200 W
– Surround L/R	200 W + 200 W
– Surround Back L/R	200 W + 200 W
Power Output** (8 Ω, 1 kHz, DIN (BTL))	
– Front L/R	280 W + 280 W
Dynamic Power***	340 W + 340 W (3 Ω, Front) 260 W + 260 W (4 Ω, Front) 175 W + 175 W (8 Ω, Front)
THD (Total Harmonic Distortion)	0.08 % (Rated Power)
Damping Factor	60 (Front, 1 kHz, 8 Ω)
Input Sensitivity and Impedance	
– Line	200 mV/50 kΩ (CD, Tape, etc.)
– Phono	2.5 mV/50 kΩ (MM)
– Multichannel	200 mV/50 kΩ (except for Subwoofer) 36 mV/50 kΩ (Subwoofer)
– Digital input Coaxial	0.5 Vp-p/75 Ω
Output Level and Impedance	
– Rec out	200 mV/470 Ω (Tape, Video 1-2)
– Line out	100 mV/470 Ω (Zone 2)
– Pre out	1.0 V/470 Ω
Frequency Response	5 Hz – 100 kHz +1 dB, -3 dB (CD in Direct mode)
Tone Control	±10 dB, 50 Hz (BASS) ±10 dB, 20 kHz (TREBLE)
Signal-to-Noise Ratio	110 dB (Line in, IHF-A) 80 dB (Phono in, IHF-A)
Speaker Impedance	4 Ω – 16 Ω
VIDEO SECTION	
Input Sensitivity/Output Level and Impedance	
– Video	1.0 Vp-p/75 Ω (Component and S-Video Y) 0.7 Vp-p/75 Ω (Component PB /CB, PR /CR) 0.28 Vp-p/75 Ω (S-Video C) 1.0 Vp-p/75 Ω (Composite)
Component Video Frequency Response	10 Hz – 50 MHz (+1 dB, -3 dB)
TUNER SECTION	
[FM]	
Tuning Frequency Range	87.5 – 108.0 MHz
Usable Sensitivity	
– FM Stereo	17.2 dBf, 2.0 μV (75 Ω IHF)
– FM Mono	11.2 dBf, 1.0 μV (75 Ω IHF)
Signal-to-Noise Ratio	
– FM Stereo	70 dB (IHF-A)
– FM Mono	76 dB (IHF-A)
THD (Total Harmonic Distortion)	
– FM Stereo	0.3 %
– FM Mono	0.2 %
50 dB Quieting Sensitivity	
– FM Stereo	37.2 dBf, 20.0 μV (75 Ω)
– FM Mono	17.2 dBf, 2.0 μV (75 Ω)
– FM Stereo Separation	45 dB at 1 kHz, 30 dB at 100 Hz – 10 kHz
[AM]	
Tuning Frequency Range	522 – 1,611 kHz
Usable Sensitivity	
– AM	30 μV
Signal-to-Noise Ratio	
– AM	40 dB
THD (Total Harmonic Distortion)	
– AM	0.7 %
GENERAL	
Power Supply	AC 230 – 240 V, 50 Hz
Power Consumption	1,200 W
Stand-by Power Consumption	3.6 W
Dimensions (W x H x D)	435 x 220 x 480.5 mm
Weight	33.0 kg

DV-SP1000E – THX Ultra Certified Universal DVD-Audio & SA-CD Player

THX® Ultra Certified	•
DVD Audio and SA-CD Decoding	•
DTS®/Dolby® Digital/Digital Audio Output	•
Dual Direct Digital Path	•
VLSC (Vector Linear Shaping Circuitry)	•
Progressive Scan	•
HDMI Output	1
Oplus FlexScale Video Scaling	•
i.LINK (IEEE 1394) Multichannel Digital Audio Sockets	2
96 kHz – 48 kHz Selectable Digital Output	•
MP3 Playback	•
Audio DAC	192 kHz/24-Bit
Video DAC	216 MHz/14-Bit
Video Circuit On/Off Control	•
Dynamic Range Control	•
Video Black Level Control	•
Digital Audio Outputs	2 Optical/2 Coaxial
Multi-channel Audio Output	•
CD-R/RW Playback Capability	•
DVD-R/RW Playback Capability*	•
S-Video, Composite Video Inputs/Outputs	1/2
Passes PLUGE Signals	•
Programmed Memory Playback	•
8-Language Soundtrack Capability	•
Display Dimmer	4-Mode
12V Trigger In	1
Component Video Outputs	2 (1 RCA/1 BNC)
IR Input/Output	1/1
RI Remote Control	•

VIDEO SECTION	
Signal System	PAL/NTSC
S-Video Output/Impedance	1.0 Vp-p/75 Ω (S-Video Y), 0.286 Vp-p/75 Ω (S-Video C) Negative sync., 4-pin Mini DIN
Component Signal Output/Impedance	(Y) 1.0 Vp-p, 75 Ω, Negative sync. (PB, PR) 0.7 Vp-p, 75 Ω
RGB Video Output/Impedance	1.0 Vp-p, 75 Ω, Scart x 1
Video Output/Impedance	1.0 Vp-p, 75 Ω, Negative sync.
AUDIO SECTION	
Frequency Response	
– DVD Audio	4 Hz – 88 kHz (192 kHz)
– DVD Liner Sound	4 Hz – 44 kHz (96 kHz) 4 Hz – 22 kHz (48 kHz) 4 Hz-20 kHz (44.1 kHz)
Audio CD	
Signal-to-Noise Ratio	118 dB
Audio Dynamic Range	100 dB
THD (Total Harmonic Distortion)	0.001 % (1 kHz)
Wow and Flutter	Below threshold of measurability
Audio Output – Optical	-22.5 dBm
Audio Output/Impedance	
– Coaxial	0.5 Vp-p/75 Ω
– Analogue	2.0 V RMS, 320 Ω
GENERAL	
Power Supply	AC 230 – 240 V, 50 Hz
Power Consumption	48 W
Dimensions (W x H x D)	435 x 123 x 374 mm
Weight	12.1 kg
Disc Compatibility	DVD-Video, DVD-Audio, SA-CD, DVD-R*/RW* (Video Mode), Music CD/CD-R/RW, Video CD, MP3, JPEG

*Disc that have not been property finalized may only be partially playable or not playable at all.

**Channels are measured separately.

***Calculated on basis of IHF Dynamic headroom.

www.eu.onkyo.com

ONKYO[®]
IMAGINATIVE SIGHT & SOUND

More information at your ONKYO dealer:

Free Manuals Download Website

<http://myh66.com>

<http://usermanuals.us>

<http://www.somanuals.com>

<http://www.4manuals.cc>

<http://www.manual-lib.com>

<http://www.404manual.com>

<http://www.luxmanual.com>

<http://aubethermostatmanual.com>

Golf course search by state

<http://golfingnear.com>

Email search by domain

<http://emailbydomain.com>

Auto manuals search

<http://auto.somanuals.com>

TV manuals search

<http://tv.somanuals.com>