

# ONKYO®

## Contents

Before Using Your DVD Receiver 2

DVD Receiver

# *DR-S2.0*

Instruction Manual

Getting Started

Basic Operation

Advanced DVD/VIDEO CD/  
Audio CD Operation

Additional Operation

Other

Thank you for purchasing the Onkyo DVD Receiver. Please read this manual thoroughly before making connections and turning on the power. Following the instructions in this manual will enable you to obtain optimum performance and listening enjoyment from your new DVD Receiver. Please retain this manual for future reference.



**WARNING:**

TO REDUCE THE RISK OF FIRE OR ELECTRIC SHOCK, DO NOT EXPOSE THIS APPLIANCE TO RAIN OR MOISTURE.

**CAUTION:**

TO REDUCE THE RISK OF ELECTRIC SHOCK, DO NOT REMOVE COVER (OR BACK). NO USER-SERVICEABLE PARTS INSIDE. REFER SERVICING TO QUALIFIED SERVICE PERSONNEL.



**WARNING**  
RISK OF ELECTRIC SHOCK  
DO NOT OPEN



The lightning flash with arrowhead symbol, within an equilateral triangle, is intended to alert the user to the presence of uninsulated "dangerous voltage" within the product's enclosure that may be of sufficient magnitude to constitute a risk of electric shock to persons.



**AVIS**  
RISQUE DE CHOC ELECTRIQUE  
NE PAS OUVRIR



The exclamation point within an equilateral triangle is intended to alert the user to the presence of important operating and maintenance (servicing) instructions in the literature accompanying the appliance.

# Important Safeguards

1. **Read Instructions** – All the safety and operating instructions should be read before the appliance is operated.
  2. **Retain Instructions** – The safety and operating instructions should be retained for future reference.
  3. **Heed Warnings** – All warnings on the appliance and in the operating instructions should be adhered to.
  4. **Follow Instructions** – All operating and use instructions should be followed.
  5. **Cleaning** – Unplug the appliance from the wall outlet (the mains) before cleaning. The appliance should be cleaned only as recommended by the manufacturer.
  6. **Attachments** – Do not use attachments not recommended by the appliance manufacturer as they may cause hazards.
  7. **Water and Moisture** – Do not use the appliance near water –for example, near a bath tub, wash bowl, kitchen sink, or laundry tub; in a wet basement; or near a swimming pool; and the like.
  8. **Accessories** – Do not place the appliance on an unstable cart, stand, tripod, bracket, or table. The appliance may fall, causing serious injury to a child or adult, and serious damage to the appliance. Use only with a cart, stand, tripod, bracket, or table recommended by the manufacturer, or sold with the appliance. Any mounting of the appliance should follow the manufacturer's instructions, and should use a mounting accessory recommended by the manufacturer.
  9. An appliance and cart combination should be moved with care. Quick stops, excessive force, and uneven surfaces may cause the appliance and cart combination to overturn. PORTABLE CART WARNING
- S3125A
10. **Ventilation** – Slots and openings in the cabinet are provided for ventilation and to ensure reliable operation of the appliance and to protect it from overheating, and these openings must not be blocked or covered. The openings should never be blocked by placing the appliance on a bed, sofa, rug, or other similar surface. The appliance should not be placed in a built-in installation such as a bookcase or rack unless proper ventilation is provided. There should be free space of at least 20 cm (8 in.) and an opening behind the appliance.
  11. **Power Sources** – The appliance should be operated only from the type of power source indicated on the marking label. If you are not sure of the type of power supply to your home, consult your appliance dealer or local power company.
  12. **Grounding or Polarization** – The appliance may be equipped with a polarized alternating current line plug (a plug having one blade wider than the other). This plug will fit into the power outlet only one way. This is a safety feature. If you are unable to insert the plug fully into the outlet, try reversing the plug. If the plug should still fail to fit, contact your electrician to replace your obsolete outlet. Do not defeat the safety purpose of the polarized plug.
  13. **Power-Cord Protection** – Power-supply cords (mains leads) should be routed so that they are not likely to be walked on or pinched by items placed upon or against them, paying particular attention to cords (leads) at plugs, convenience receptacles, and the point where they exit from the appliance.
  14. **Outdoor Antenna (Aerial) Grounding** – If an outside antenna (aerial) or cable system is connected to the appliance, be sure the antenna (aerial) or cable system is grounded so as to provide some protection against voltage surges and built-up static charges. Article 810 of the National Electrical Code, ANSI/NFPA 70, provides information with regard to proper grounding of the mast and supporting structure, grounding of the lead-in wire to an antenna- (aerial-) discharge unit, size of grounding conductors, location of antenna- (aerial-) discharge unit, connection to grounding electrodes, and requirements for the grounding electrode. See FIGURE 1.
  15. **Lightning** – For added protection for the appliance during a lightning storm, or when it is left unattended and unused for long periods of time, unplug it from the wall outlet (the mains) and disconnect the antenna (aerial) or cable system. This will prevent damage to the appliance due to lightning and power-line surges.
  16. **Power Lines** – An outside antenna (aerial) system should not be located in the vicinity of overhead power lines or other electric light or power circuits, or where it can fall into such power lines or circuits. When installing an outside antenna (aerial) system, extreme care should be taken to keep from touching such power lines or circuits as contact with them might be fatal.
  17. **Overloading** – Do not overload wall outlets, extension cords (leads), or integral convenience receptacles as this can result in a risk of fire or electric shock.
  18. **Object and Liquid Entry** – Never push objects of any kind into the appliance through openings as they may touch dangerous voltage points or short-out parts that could result in a fire or electric shock. Never spill liquid of any kind on the appliance.
  19. **Servicing** – Do not attempt to service the appliance yourself as opening or removing covers may expose you to dangerous voltage or other hazards. Refer all servicing to qualified service personnel.
  20. **Damage Requiring Service** – Unplug the appliance from the wall outlet (the mains) and refer servicing to qualified service personnel under the following conditions:
    - A. When the power-supply cord (mains lead) or plug is damaged,
    - B. If liquid has been spilled, or objects have fallen into the appliance,
    - C. If the appliance has been exposed to rain or water,
    - D. If the appliance does not operate normally by following the operating instructions. Adjust only those controls that are covered by the operating instructions as an improper adjustment of other controls may result in damage and will often require extensive work by a qualified technician to restore the appliance to its normal operation,
    - E. If the appliance has been dropped or damaged in any way, and
    - F. When the appliance exhibits a distinct change in performance – this indicates a need for service.

21. **Replacement Parts** – When replacement parts are required, be sure the service technician has used replacement parts specified by the manufacturer or have the same characteristics as the original part. Unauthorized substitutions may result in fire, electric shock, or other hazards.
22. **Safety Check** – Upon completion of any service or repairs to the appliance, ask the service technician to perform safety checks to determine that the appliance is in proper operation condition.
23. **Wall or Ceiling Mounting** – The appliance should be mounted to a wall or ceiling only as recommended by the manufacturer.
24. **Heat** – The appliance should be situated away from heat sources such as radiators, heat registers, stoves, or other appliances (including amplifiers) that produce heat.

FIGURE 1:  
EXAMPLE OF ANTENNA (AERIAL) GROUNDING AS PER NATIONAL ELECTRICAL CODE, ANSI/NFPA 70

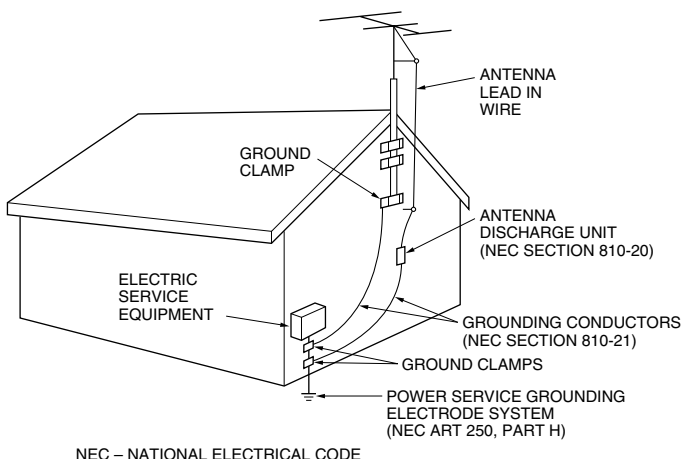

S2898A

# Precautions

## CAUTION:

VISIBLE LASER RADIATION WHEN OPEN AND INTERLOCK FAILED OR DEFEATED. DO NOT STARE INTO BEAM.

## CAUTION:

THIS PRODUCT UTILIZES A LASER. USE OF CONTROLS OR ADJUSTMENTS OR PERFORMANCE OF PROCEDURES OTHER THAN THOSE SPECIFIED HEREIN MAY RESULT IN HAZARDOUS RADIATION EXPOSURE.

This unit contains a semiconductor laser system and is classified as a "CLASS 1 LASER PRODUCT." So, to use this model properly, read this Instruction Manual carefully. In case of any trouble, please contact the store where you purchased the unit. To prevent being exposed to the laser beam, do not try to open the enclosure.



This label on the rear panel states that:

1. This unit is a CLASS 1 LASER PRODUCT and employs a laser inside the cabinet.
2. To prevent the laser from being exposed, do not remove the cover. Refer servicing to qualified personnel.

## For British model

Replacement and mounting of an AC plug on the power supply cord of this unit should be performed only by qualified service personnel.

## IMPORTANT

The wires in the mains lead are coloured in accordance with the following code:

Blue : Neutral  
Brown : Live

As the colours of the wires in the mains lead of this apparatus may not correspond with the coloured markings identifying the terminals in your plug, proceed as follows:

The wire which is coloured blue must be connected to the terminal which is marked with the letter N or coloured black.

The wire which is coloured brown must be connected to the terminal which is marked with the letter L or coloured red.

## IMPORTANT

A 5 ampere fuse is fitted in this plug. Should the fuse need to be replaced, please ensure that the replacement fuse has a rating of 5 amperes and that it is approved by ASTA or BSI to BS1362. Check for the ASTA mark or the BSI mark on the body of the fuse.

**IF THE FITTED MOULDED PLUG IS UNSUITABLE FOR THE SOCKET OUTLET IN YOUR HOME THEN THE FUSE SHOULD BE REMOVED AND THE PLUG CUT OFF AND DISPOSED OF SAFELY. THERE IS A DANGER OF SEVERE ELECTRICAL SHOCK IF THE CUT OFF PLUG IS INSERTED INTO ANY 13 AMPERE SOCKET.**

If in any doubt, please consult a qualified electrician.

## Declaration of Conformity

We, ONKYO EUROPE  
ELECTRONICS GmbH  
INDUSTRIESTRASSE 20  
82110 GERMERING,  
GERMANY



declare in own responsibility, that the ONKYO product described in this instruction manual is in compliance with the corresponding technical standards such as EN60065, EN55013, EN55020 and EN61000-3-2, -3-3 (or EN60555-2, -3)

GERMERING, GERMANY

*A. Horichi*  
A.HORIUCHI

ONKYO EUROPE ELECTRONICS GmbH

# Precautions

## 1. Regional Restriction Codes (Region Number)

Regional restriction codes are built into DVD players and DVD videos for each sales region. If the regional code of the DVD Receiver does not match one of the regional codes on the DVD video, playback is not possible.

The regional number can be found on the rear panel of the DVD Receiver. (e.g.  for Region 2)

## 2. About This Manual

This manual explains the basic procedures for operating the DVD Receiver. Some DVD videos do not support the full potential of the DVD technology. Your DVD Receiver may therefore not respond to all operating commands. Refer to instruction notes on discs.

A “” mark may appear on the TV screen during operation. It means that the operation is not permitted by the DVD Receiver or the disc.

## 3. Warranty Claim

You can find the serial number on the rear panel of the unit. In case of warranty claim, please report this number.

## 4. Recording Copyright

Recording of copyrighted material for other than personal use is illegal without permission of the copyright holder.

## 5. AC Fuse

The fuse is located inside the chassis and is not user-serviceable. If power does not come on, contact your Onkyo authorized service center.

## 6. Power

### WARNING

BEFORE PLUGGING IN THE UNIT FOR THE FIRST TIME, READ THE FOLLOWING SECTION CAREFULLY.

The voltage of the available power supply differs according to country or region. Be sure that the power supply voltage of the area where the unit will be used meets the required voltage (e.g. AC230-240V, 50Hz) written on the rear panel.

## 7. Do not touch the unit with wet hands

Do not handle the unit or power cord (mains lead) when your hands are wet or damp. If water or any other liquid enters the case, take the unit to an authorized service center for inspection.

## 8. Location of the unit

- Place the unit in a well-ventilated location.  
Take special care to provide plenty of ventilation on all sides of the unit especially when it is placed in an audio rack. If ventilation is blocked, the unit may overheat and malfunction.
- Do not expose the unit to direct sunlight or heating units as the unit's internal temperature may rise and shorten the life of the pickup.
- Avoid damp and dusty places and places directly affected by vibrations from the speakers. In particular, avoid placing the unit on or above one of the speakers.
- Be sure the unit is placed in a horizontal position. Never place it on its side or on a slanted surface as it may malfunction.
- When you place the unit near a TV, radio, or VCR, the playback picture may become poor and the sound may be distorted. In this case, place the unit away from the TV, radio, or VCR.

## 9. Care

From time to time you should wipe the front and rear panels and the cabinet with a soft cloth. For heavier dirt, dampen a soft cloth in a weak solution of mild detergent and water, wring it out dry, and wipe off the dirt. Following this, dry immediately with a clean cloth. Do not use rough material, thinners, alcohol or other chemical solvents or cloths since these could damage the finish or remove the panel lettering.

## 10. Notes on Handling

- When shipping the unit, use the original shipping carton and packing materials. For maximum protection, repack the unit as it was originally packed at the factory.
- Do not use volatile liquids, such as insect spray, near the unit. Do not leave rubber or plastic products in contact with the unit for a long time. They will leave marks on the finish.
- The top and rear panels of the unit **may become warm after a long period of use. This is not a malfunction.**
- When the unit is not in use, be sure to remove the disc and turn off the power.
- If you do not use the unit for a long period, the unit may not function properly in the future. Turn on and use the unit occasionally.

## 11. To Obtain a Clear Picture

The unit is a high technology, precision device. If the optical pick-up lens and disc drive parts are dirty or worn down, the picture quality becomes poor. To obtain a clear picture, we recommend regular inspection and maintenance (cleaning or parts replacement) every 1,000 hours of use depending on the operating environment. For details, contact your nearest dealer.

## 12. Notes on Moisture Condensation

**Moisture condensation damages the unit.**

**Please read the following carefully.**

- What is moisture condensation?**  
Moisture condensation occurs, for example, when you pour a cold drink into a glass on a warm day. Drops of water form on the outside of the glass. In the same way, moisture may condense on the optical pick-up lens inside the unit, one of the most crucial internal parts of the unit.
- Moisture condensation occurs in the following cases.**
  - When you bring the unit directly from a cold place to a warm place.
  - When you use the unit in a room where you just turned on the heater, or a place where the cold wind from the air conditioner directly hits the unit.
  - In summer, when you use the unit in a hot and humid place just after you move the unit from an air conditioned room.
  - When you use the unit in a humid place.
- Do not use the unit when moisture condensation may occur.**  
If you use the unit in such a situation, it may damage discs and internal parts. Remove the disc, connect the power cord (mains lead) of the unit to the wall outlet (the mains), turn on the unit, and leave it for two or three hours. After a few hours, the unit will have warmed up and evaporated any moisture. Keep the unit connected to the wall outlet (the mains) and moisture condensation will seldom occur.

# Table of Contents

Important Safeguards/Precautions/Table of Contents .....	2-5
--	-----

## Getting Started

Features .....	6
Supplied Accessories .....	7
Preparing the Remote Controller .....	8
Notes on Discs .....	9
Connecting to a TV .....	10
Connecting to Audio/Video Equipment .....	11
Positioning Speakers .....	12
Connecting Speakers .....	13
Making Antenna (Aerial) Connections .....	14
<b>RI</b> Connection for the Onkyo Cassette Tape Deck .....	15
Connecting the Power/Turning on the DVD Receiver .....	16
Speaker Setup .....	17

## Basic Operation

Playing DVD Videos/VIDEO CDs/Audio CDs .....	20
Listening to the Radio .....	26
Playing the Connected Source .....	28
Various Functions Common to all the Sources .....	30
Enjoying the Sound Effects .....	32

## Advanced DVD/VIDEO CD/Audio CD Operation

Playing Repeatedly .....	39
Playing in a Favorite Order .....	40
Playing in Random Order .....	41
Zooming in on a Picture .....	42
Selecting the Camera Angle .....	43
Turning on/off Subtitles/Selecting the Subtitle Language .....	44
Selecting Audio Language/Sound Included on the Disc .....	45
Changing the Sound Signal Conversion Method .....	46
Using Information on the On-Screen Display and the DVD Receiver's Display ..	48
Customizing the Function Settings .....	50
Table of Languages .....	58

## Additional Operation

Recording Using the Connected Equipment .....	59
Programming the Remote Controller to Your TV .....	61

## Other

Troubleshooting .....	63
Specifications .....	65
<b>Index to Parts and Controls .....</b>	<b>66</b>

# Features

## ■ Receiver Features

- 5 × 30 W/Ch into 6 ohms
- 96 kHz/24-Bit DAC System
- DTS\* & Dolby\*\* Digital Decoders
- Acoustic Control
- 2 Digital Inputs/1 Output
- Subwoofer Preout
- 4 Audio Inputs/2 Outputs
- 2 S-Video Inputs/2 Outputs
- Multichannel Theater-Dimensional\*\*\*
- Easy-Set Speaker Configuration
- 30 FM/AM Random Presets
- Full-Function Learning Remote

\* Manufactured under license from Digital Theater Systems, Inc. US Pat. No.5,451,942 and other worldwide patents issued and pending, "DTS" and "DTS Digital Surround" are trademarks of Digital Theater Systems, Inc. ©1996 Digital Theater Systems, Inc. All Rights reserved.

\*\* Manufactured under license from Dolby Laboratories. "Dolby", "Pro Logic" and the double-D symbol are trademarks of Dolby Laboratories. Confidential Unpublished Works. ©1992-1997 Dolby Laboratories. All rights reserved.

\*\*\* "Theater-Dimensional" and  are trademarks of Onkyo Corporation.

## ■ DVD/CD Player Features

- DTS, Dolby Digital, and PCM Compatible
- SCART Connector
- 27 MHz/10-Bit Video DAC
- Plays DVDs, CDs, CD-Rs and Video CDs
- Enhanced Black-Level Control
- High-Resolution Onscreen Display
- 3-Mode Zoom Function
- Program Memory Playback
- Auto Last Play
- Dual-Wavelength Optical Pickup
- Sand-Blasted Aluminum Front Panel

### Memory Preservation

This unit does not require memory preservation batteries. A built-in memory power backup system preserves the contents of memory during power failures and even when the POWER switch is set to OFF.

The POWER switch must be set to ON in order to charge the backups system. The memory preservation period after the unit has been turned off varies depending on climate and placement of the unit. On average, memory contents are protected over a period of a few weeks after the time the unit has been turned off. This period is shorter when the unit is exposed to a very humid climate.

# Supplied Accessories

Make sure your box contains everything listed below.  
If any pieces are missing, contact your nearest Onkyo dealer.  
The number of accessories is indicated in brackets.

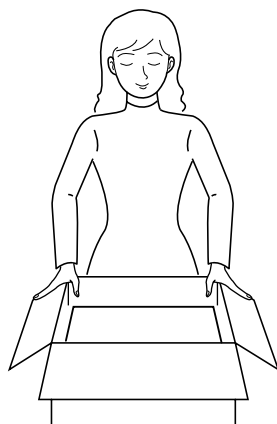

Remote controller (RC-437M) [1]

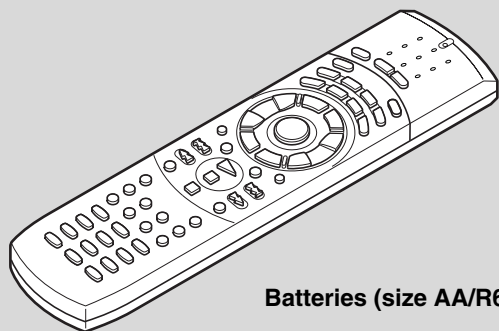

Batteries (size AA/R6/UM3) [2]

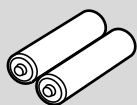

SCART cable [1]

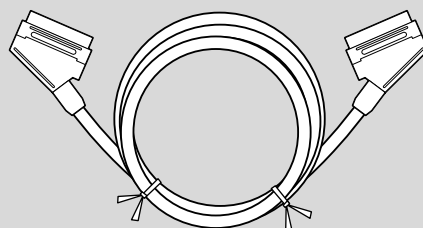

FM antenna (aerial) [1]

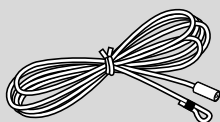

AM loop antenna (aerial) [1]

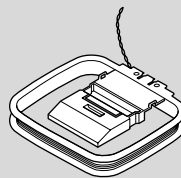

# Preparing the Remote Controller

## Inserting the Batteries

- 1 Detach the battery cover.
- 2 Insert the two size AA/R6/UM3 batteries.  
Be sure to match the + and - ends of the batteries with the diagram inside the battery compartment.
- 3 Attach the battery cover.

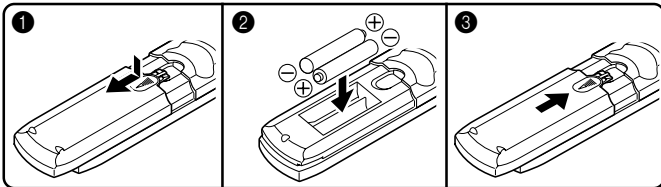

### Notes

- When the batteries are getting weak, the SEND/LEARN indicator on the remote controller starts flashing. In this case, replace the batteries with new ones.  
For the other functions of this indicator, see "Pointing the remote controller in the right direction" on the right, and page 61.
- Do not mix new batteries with old batteries or different kinds of batteries.
- To avoid corrosion, remove the batteries if the remote controller is not to be used for a long time.
- Remove dead batteries immediately to avoid damage from corrosion. If the remote controller does not operate smoothly, replace both batteries at the same time.
- The life of the supplied batteries is about six months but this varies depending on usage.

SEND/LEARN indicator

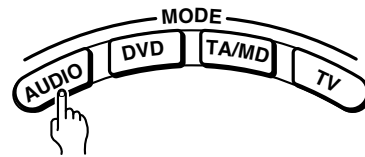
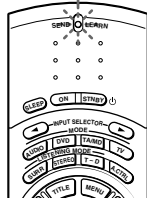

Press **MODE AUDIO** first before operating the speaker setting and sound related operations.

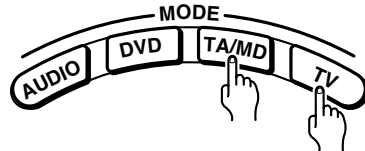

Press **MODE TA/MD** first before operating the Onkyo MD recorder or **RI**-connected cassette tape deck (see pages 15 and 29).

Press **MODE TV** first before operating your TV.  
To operate the TV with the supplied remote controller, you need to let the remote controller learn the TV remote control signals (see pages 29 and 61).

## Pointing the remote controller in the right direction

Point the remote controller toward the remote control sensor.

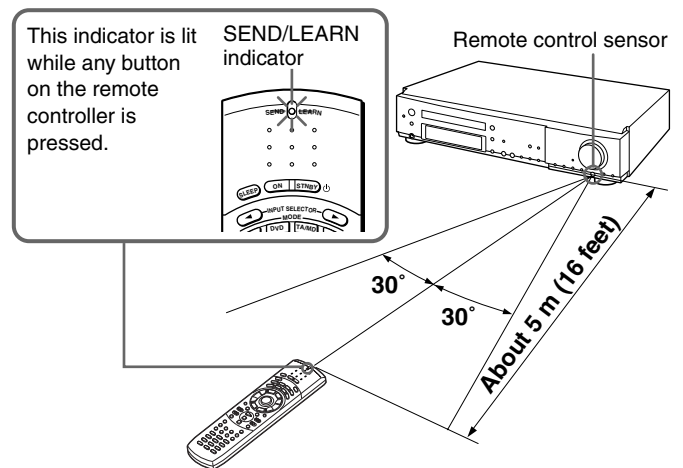

### Notes

- Place the unit away from strong light such as direct sunlight or inverted fluorescent light which can prevent proper operation of the remote controller.
- Using another remote controller of the same type in the same room or using the unit near equipment which uses infrared rays may cause operational interference.
- Do not put any object (such as a book) on the remote controller. The buttons of the remote controller may be pressed by mistake and drain the batteries.
- Make sure the audio rack doors do not have colored glass. Placing the unit behind such doors may prevent proper remote controller operation.
- If there is any obstacle between the remote controller and the remote control sensor, the remote controller will not operate.

## Using the Remote Controller

### Switching the remote controller function modes

Some buttons on the remote controller have two or more functions. To set the functionality of these buttons, press one of the four **MODE** (AUDIO, DVD, TA/MD, TV) buttons in advance.

The function mode remains the same until another **MODE** button is pressed.

(Details about the functions and the related function modes are explained in each section.)

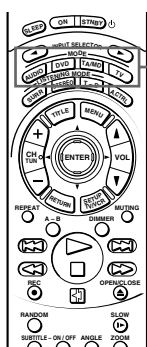

**MODE buttons**

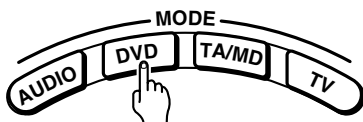

Press **MODE DVD** first before operating the built-in DVD player.





# Notes on Discs

This section shows you how to handle, clean, and store discs.

## Playable Discs

This DVD Receiver can playback the following discs.

	Disc mark	Contents	Disc size	Maximum playback time
DVD videos		Audio + Video (moving pictures)	12 cm	Approx. 4 hours (single sided disc)
				Approx. 8 hours (double sided disc)
			8 cm	Approx. 80 minutes (single sided disc)
				Approx. 160 minutes (double sided disc)
VIDEO CDs		Audio + Video (moving pictures)	12 cm	Approx. 74 minutes
			8 cm	Approx. 20 minutes
Audio CDs*		Audio	12 cm	Approx. 74 minutes
			8 cm (CD single)	Approx. 20 minutes

\* Finalized CD-Rs are also playable. Such CD-Rs that TOC (Table of Contents) information (such as track numbers) are recorded on to the PMA — a special area in the disc is described as finalized CD-Rs.

- You cannot playback discs other than those listed above.
- You cannot play discs such as CD-RW, CD-ROM, DVD-RAM, DVD-RW, etc., even if the marks in the above table are labeled on those discs.
- This DVD Receiver uses the PAL/NTSC color system, and cannot playback DVD videos recorded in any other color system (SECAM, etc.).
- Avoid using heart-shaped or octagonal discs. Playing irregularly shaped discs may damage the internal mechanism of the DVD Receiver.

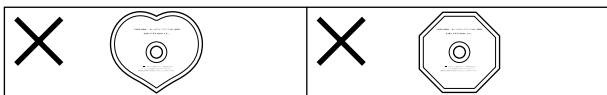

- Do not use discs that have residue from adhesive tape, rental discs that have peeling labels, or discs that have custom labels or stickers. Otherwise, you may not be able to eject the discs or the DVD Receiver may become inoperative.

## Handling Discs

- Do not touch the playback side of the disc.

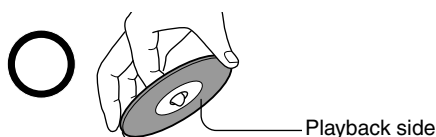

- Do not attach paper or tape to discs.



## Cleaning Discs

- Fingerprints and dust on the disc cause picture and sound deterioration. Wipe the disc from the center outwards with a soft cloth. Always keep the disc clean.

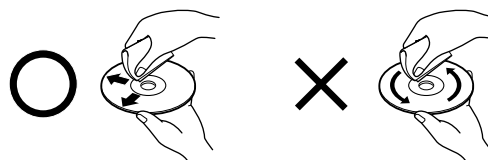

- If you cannot wipe off the dust with a soft cloth, wipe the disc lightly with a slightly moistened soft cloth and finish with a dry cloth.
- Do not use any type of solvent such as thinner, benzene, commercially available cleaners or antistatic spray for vinyl LPs. It may damage the disc.

## Storing Discs

- Do not store discs in a place subject to direct sunlight or near heat sources.
- Do not store discs in places subject to moisture and dust such as a bathroom or near a humidifier.
- Store discs vertically in a case. Stacking or placing objects on discs outside of their case may cause warping.

## About VIDEO CDs

This DVD Receiver supports VIDEO CDs equipped with the PBC (Version 2.0) function. (PBC is the abbreviation for Playback Control.)

You can enjoy two playback variations depending on the type of disc.

- VIDEO CD not equipped with PBC function (Version 1.1)**  
Sound and movies can be played on this DVD Receiver in the same way as an audio CD.
- VIDEO CD equipped with PBC function (Version 2.0)**  
In addition to operation of a VIDEO CD not equipped with the PBC function, you can enjoy playback with interactive software and search function using the menu displayed on the TV screen (Menu Playback). Some of the functions described in this Instruction Manual may not work with some discs.

## Notes on Copyright

It is forbidden by law to copy, broadcast, show, broadcast on cable, play in public, and rent copyrighted material without permission.

DVD videos are copy protected, and any recordings made from these discs will be distorted.

This product incorporates copyright protection technology that is protected by method claims of certain U.S. patents and other intellectual property rights owned by Macrovision Corporation and other rights owners. Use of this copyright protection technology must be authorized by Macrovision Corporation, and is intended for home and other limited viewing uses only unless otherwise authorized by Macrovision Corporation. Reverse engineering or disassembly is prohibited.

# Connecting to a TV

## Before connecting

- Refer also to the instruction manual of the TV.
- When you connect the DVD Receiver to the TV, be sure to turn off the power and unplug both the units from the mains before making any connections.
- Connect the DVD Receiver to the TV directly. If you connect the DVD Receiver to a VCR, TV/VCR combination, or video selector, the playback picture may be distorted as DVD videos are copy protected.

- Connect the plugs securely.

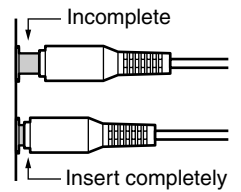

### Connecting to a TV Using the SCART Cable

Connect the DVD Receiver and your TV using the supplied SCART cable.

#### If the TV is compatible with S video signals

Set "Video Out Select" to "S Video" using the menu explained in "Customizing the Function Settings" starting from page 50 after completing the steps on page 16. See page 53 for direct information.

#### If an RGB monitor is connected to the DVD Receiver

Set "Video Out Select" to "RGB" using the menu explained in "Customizing the Function Settings" starting from page 50 after completing the steps on page 16. See page 53 for direct information.

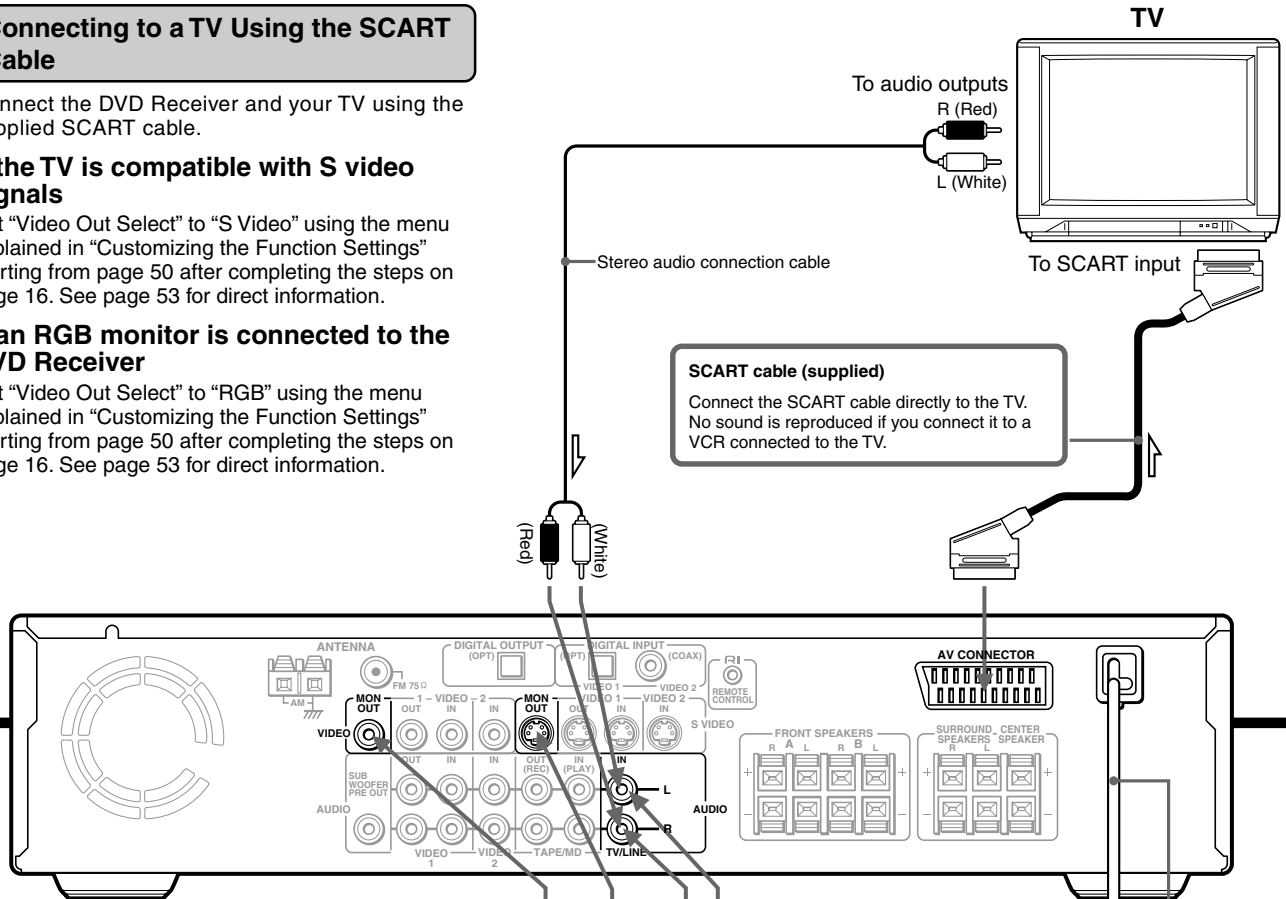

### Connecting to a TV Using the Audio/Video Connection Cable

If the TV is equipped with an S video input, make the S video connection in addition to the normal video connection. (The S video connection will provide higher quality picture playback.) In this case, set "Video Out Select" to "S Video" using the menu explained in "Customizing the Function Settings" starting from page 50 after completing the steps on page 16. See page 53 for direct information.

#### If an RGB monitor is connected to the DVD Receiver

Set "Video Out Select" to "RGB" using the menu explained in "Customizing the Function Settings" starting from page 50 after completing the steps on page 16. See page 53 for direct information.

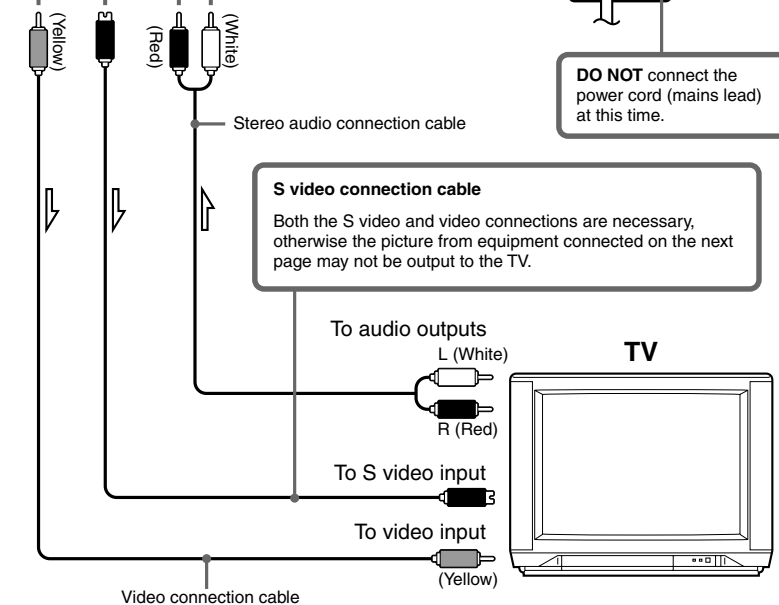

➤ : Signal flow

# Connecting to Audio/Video Equipment

## Before connecting

- Refer also to the instruction manual of each component to be connected.
- When you connect the DVD Receiver to audio/video equipment, be sure to turn off the power and unplug all the units from the mains before making any connections.
- **About the DIGITAL INPUT (OPT) and DIGITAL OUTPUT (OPT) connectors**  
Remove the protective caps before making connections. When not in use, be sure to replace them.

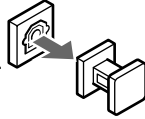

## About the VIDEO 1 and VIDEO 2 jacks/connectors

- The video input/output connections are also necessary even if you make the S video input/output connections.
- Connect the plugs securely.

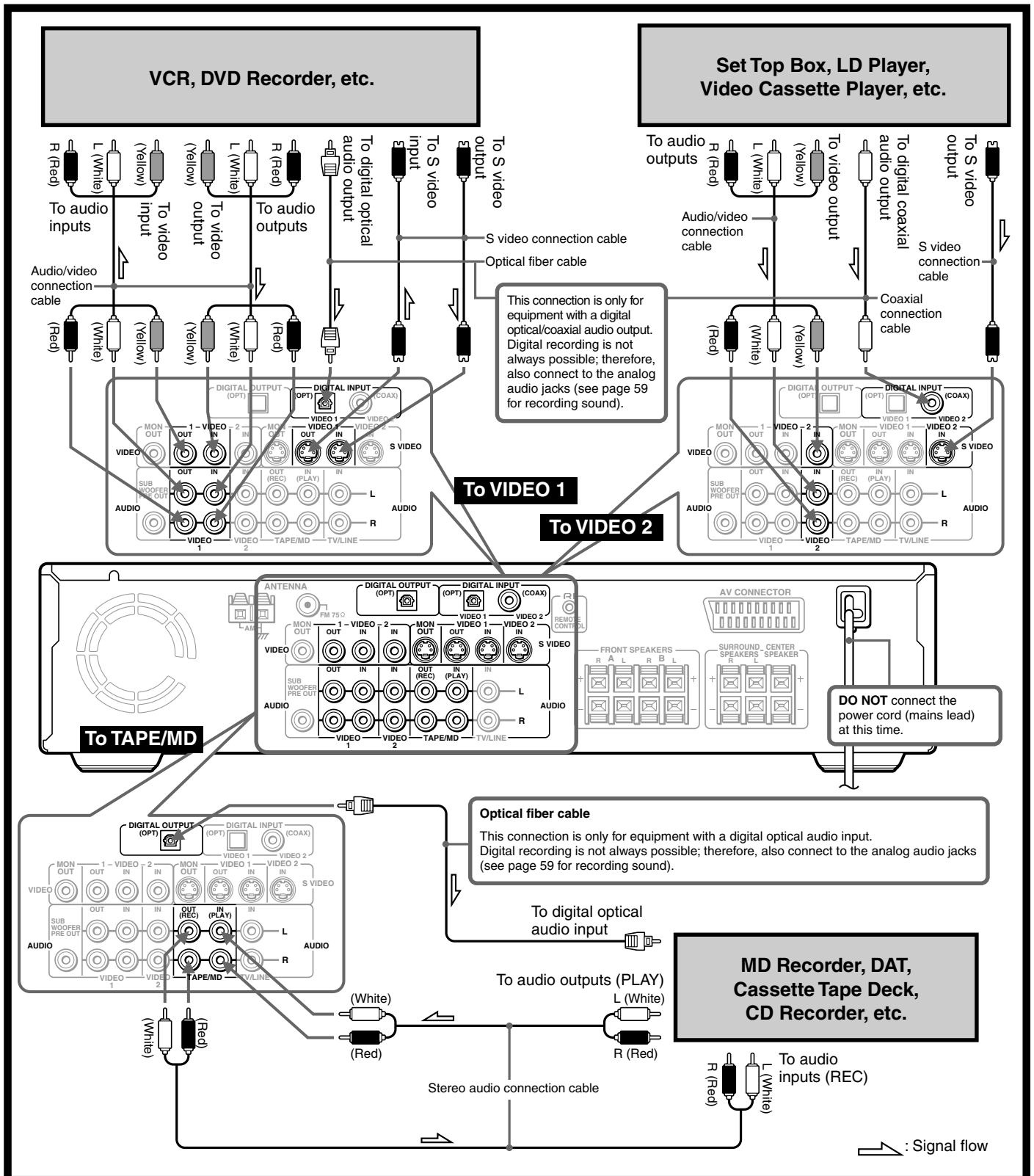
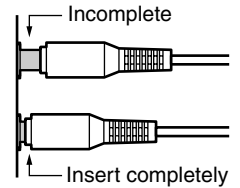

# Positioning Speakers

Two speaker systems (SPEAKERS A and SPEAKERS B) can be connected to the DVD Receiver. The SPEAKERS A system is to be placed in the main room, and the SPEAKERS B system is to be placed in a second room.

## The configuration of the SPEAKERS A system

The SPEAKERS A system consists of the front left, center, and right speakers, surround left and right speakers, and subwoofer. You can reproduce the sounds such as Dolby surround and DTS surround.

## The configuration of the SPEAKERS B system

The SPEAKERS B system consists of the front left and right speakers. You can reproduce only monaural and stereo sounds.

### ■ Standard speaker placement of the SPEAKERS A system

Speaker placement plays an important role in the reproduction of Surround sound. The placement of the speakers varies depending on the size of the room and the wall coverings used in the room. The illustration below shows an example of a layout for standard speaker placement. Refer to this example when you position the speakers in order to experience the best of Surround sound.

For ideal Surround effects, all speakers should be installed.

If a center speaker or subwoofer is not connected, the sound from the unused channel is properly distributed to the connected speakers in order to reproduce the best Surround sound possible.

### Front

The center speaker reproduces a richer sound image by enhancing the perception of the sound's source and movement.

The left, right, and center speakers should face the seated listener and be placed at ear level.

### Surround

The surround speakers reproduce the feel of a moving sound while creating the sensation of being in the middle of the action.

Place the left and right surround speakers 1 meter (3 feet) above the listener's ear level and facing toward the sides of the room, making sure that the listener is within the speakers' dispersion angle.

### Subwoofer

Install a subwoofer with a built-in power amplifier for powerful bass sounds.

The placement of the subwoofer does not affect the final quality of the sound image much, therefore, you can install it wherever it is convenient.

Refer to the speakers' instruction manuals for details.

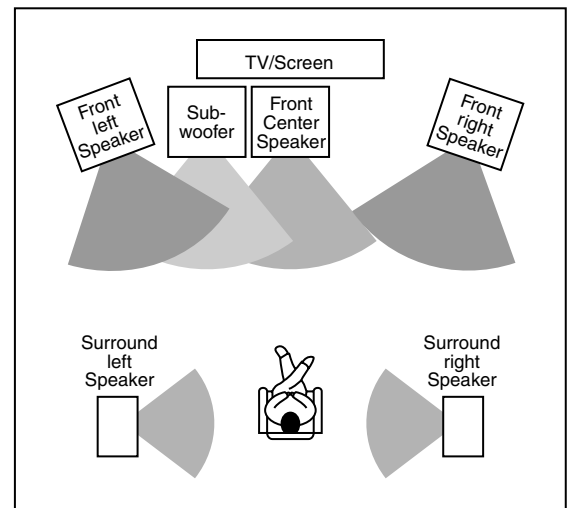

# Connecting Speakers

## Before connecting

- Refer also to the instruction manuals of the speakers.
- This DVD Receiver is designed to reproduce optimum sound quality when speakers with the impedances specified below are connected. Please check the following information and choose speakers with appropriate impedances for the connections.  
**Front speakers: 6 ohms min. per speaker**  
**Center speaker: 6 ohms min.**  
**Surround Speakers : 6 ohms min. per speaker**
- Strip 10 mm from the end of each cord, then twist the exposed wires tightly.

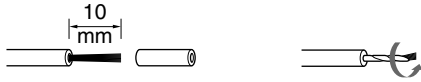

- To prevent damage to circuits, never short-circuit the positive (+) and negative (-) speaker wires.
- Do not connect the speaker cable to the L and R connectors at the same time and do not connect more than one speaker to the same speaker connectors.

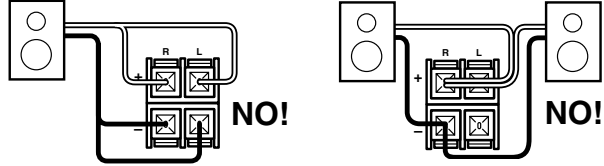

## Connecting to SPEAKERS A

The main speaker system is SPEAKERS A. Follow the illustration on the right.

### How to connect to the speaker connectors

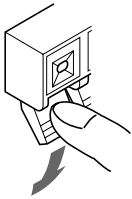

Press and hold the lever.

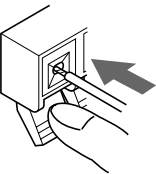

Insert the stripped end of the cord.  
By releasing the lever, the lever is replaced.

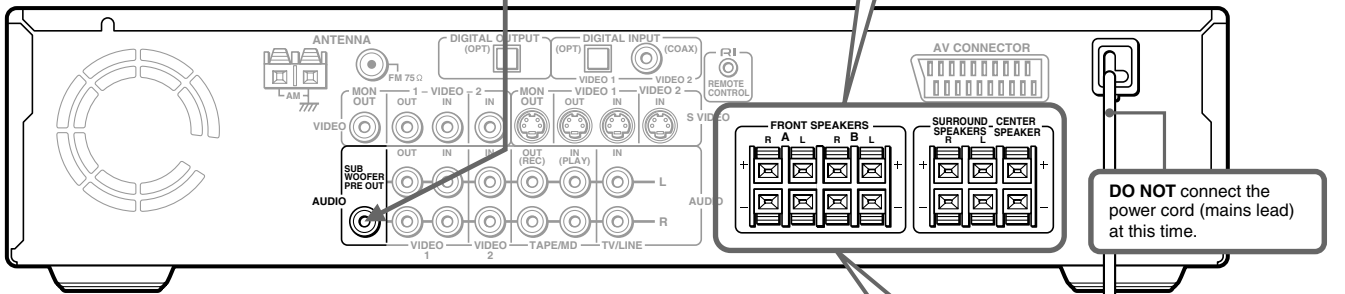
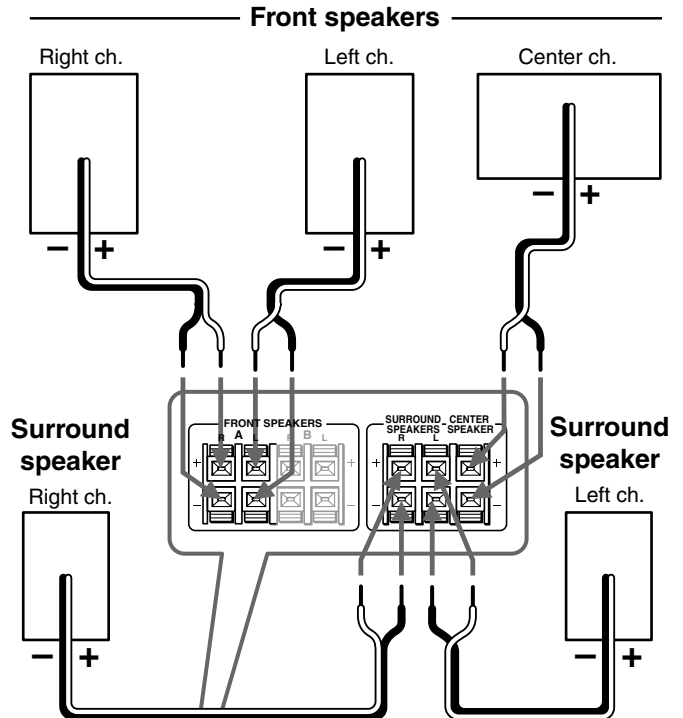
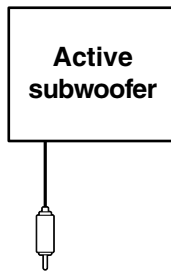

## Connecting to SPEAKERS B

To place the additional speaker system for the second room, make the SPEAKERS B connection on the right.

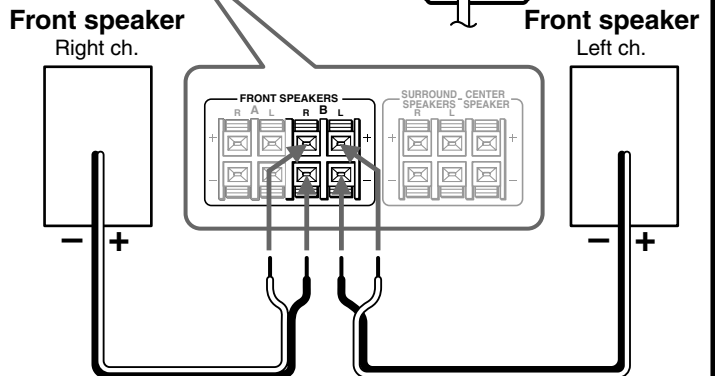

# Making Antenna (Aerial) Connections

## Connecting the Supplied FM and AM Indoor Antennas (Aerials)

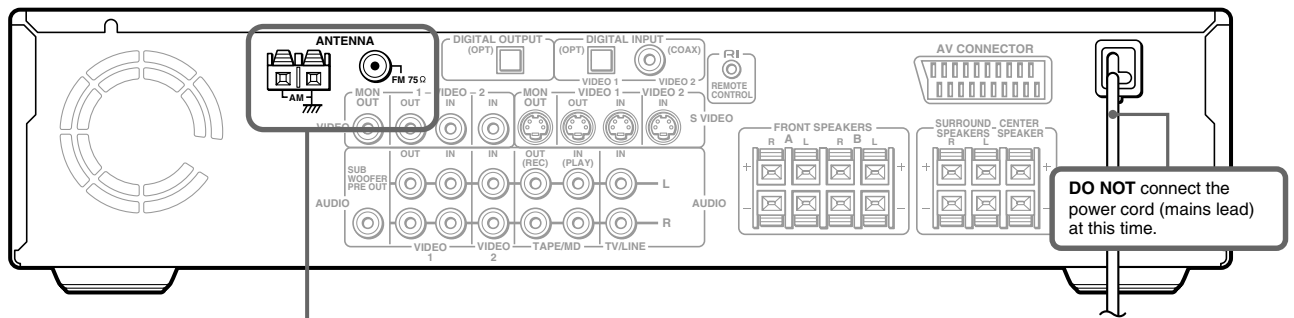

Insert into the hole.

Press up and hold the lever.

Insert the end of the cord.

Release the lever to secure the connection.

AM indoor antenna (aerial)

FM indoor antenna (aerial)

ANTENNA

FM 75Ω

**■ Adjusting the position of the FM indoor antenna (aerial)**

While listening to an FM program (see page 26), extend the antenna (aerial) and move it in various directions until the clearest signal is received, then secure the antenna (aerial) with push pins in the position with the least distortion.

**■ Adjusting the position of the AM indoor antenna (aerial)**

While listening to an AM program (see page 26), set the antenna (aerial) in the direction and position where you receive the clearest sound. Put it as far away as possible from the unit, TVs, speaker cables, and power cords (mains leads).

**Note**  
Insert one end of the AM antenna (aerial) cord to either of the AM antenna (aerial) connectors and the other end to the other connector. There is no difference between one end of the AM antenna (aerial) cord and the other end, unlike the speaker cords which have positive and negative poles.

## Connecting an AM Outdoor Antenna (Aerial)

An outdoor antenna (aerial) will be more effective if it is stretched horizontally above a window or outside. Leave the supplied AM indoor antenna (aerial) connected.

**Note**  
To avoid the risk of lightning and electrical shock, grounding is necessary. Follow item 14 of the "Important Safeguards" on page 2 when you install an outdoor antenna (aerial).

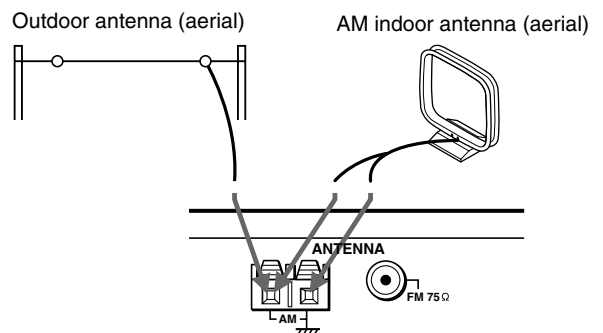

## Connecting an FM Outdoor Antenna (Aerial)

If the FM reception is not very clear with the supplied antenna (aerial), connect an FM outdoor antenna (aerial) instead of the indoor FM antenna (aerial).

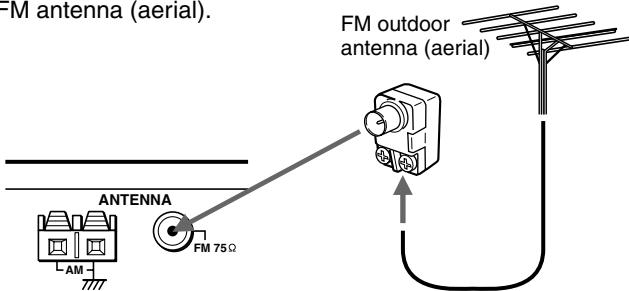

### Notes

- Install the antenna (aerial) well away from tall buildings and in an area where FM stations can directly be received.
- Keep the antenna (aerial) away from noise sources (neon signs, busy roads, etc.).
- It is dangerous to put the antenna (aerial) close to power lines. Keep it well away from power lines, transformers, etc.
- To avoid the risk of lightning and electrical shock, grounding is necessary. Follow item 14 of the "Important Safeguards" on page 2 when you install the outdoor antenna (aerial).

### Directional linkage

Do not use the same antenna (aerial) for both FM and TV (or VCR) reception since the FM and TV (or VCR) signals can interfere with each other. If you must use a common FM/TV (or VCR) antenna (aerial), use a directional linkage type splitter.

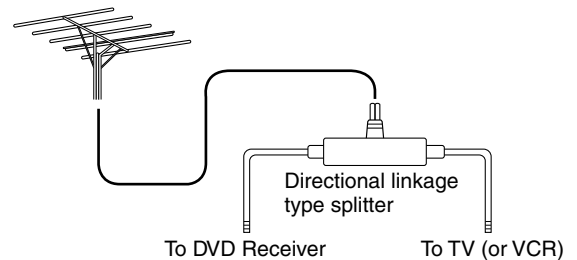

## RI Connection for the Onkyo Cassette Tape Deck

The supplied remote controller has the following three extended functions in addition to operating the DVD Receiver:

- First, operating the TV (see page 29),
- Second, operating the Onkyo MD recorder (no RI connection is needed) (see page 29), and
- Third, operating the RI connected Onkyo cassette tape deck through the DVD Receiver (see page 29).

To use the third function, you need to make the RI connection between the cassette tape deck and the DVD Receiver. The RI cable to make the RI connection is supplied with the cassette tape deck.

If you start playing back the cassette tape deck after making the RI connection, the DVD Receiver automatically changes its input source to the cassette tape deck — Direct Change function.

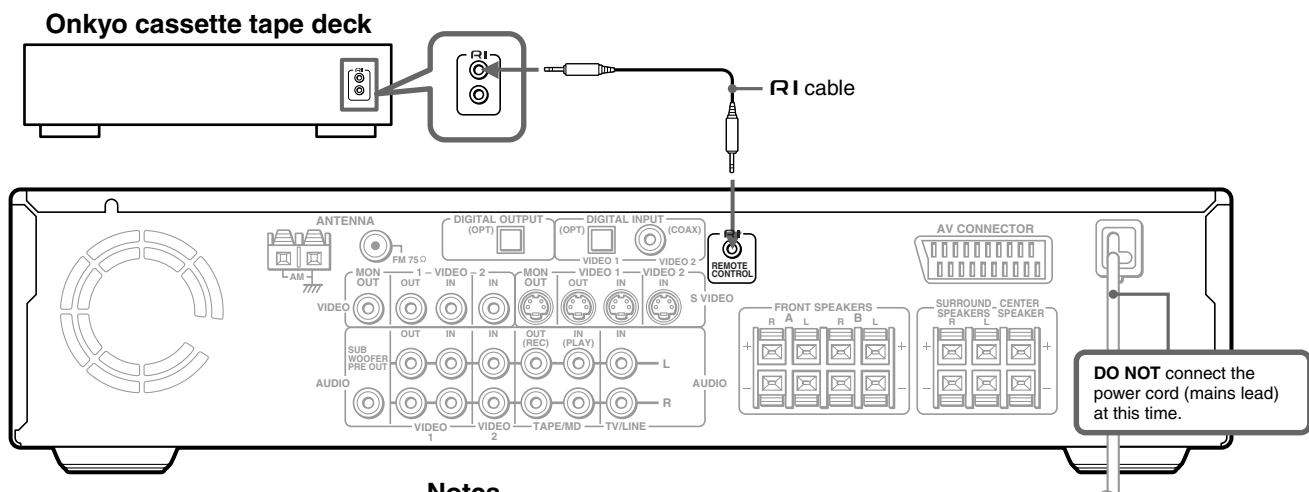

### Notes

- Connect the plugs securely.
- Be sure to connect to the RI connectors using the RI cable.
- The connections on page 11 are needed even if RI connection is made.
- Do not connect the DVD Receiver's RI connector to any component other than an Onkyo product. It may cause malfunction.

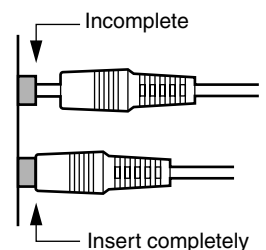

# Connecting the Power/Turning on the DVD Receiver

## Before connecting

- Make sure that all the connections from pages 10 to 15 are complete (the connection to the TV is required).
- Turning on the DVD Receiver may cause a momentary power surge, which might interfere with other electrical equipment such as computers. If this happens, use a wall outlet on a different circuit.

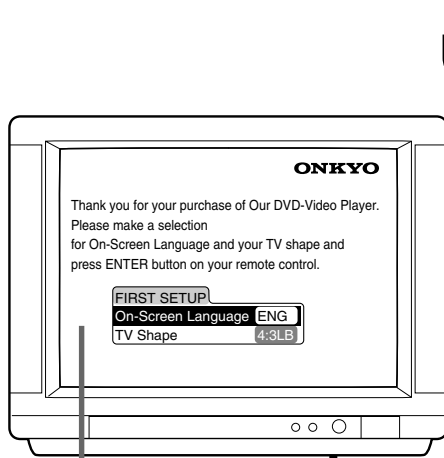



**1** Connect the power cord (mains lead) to a wall outlet (the mains).

**2** Press the  POWER switch to switch on the main power.

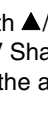
The DVD Receiver enters standby mode. The STANDBY indicator lights up.

 STANDBY

**Notes**

- To switch off the main power, press the  POWER switch again.
- The buttons on the remote controller don't operate if the  POWER switch is set to OFF.

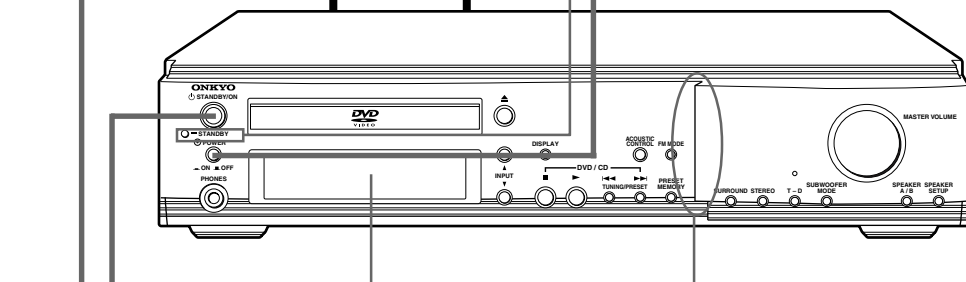







**Before operating the cursor**  
Press MODE DVD or MODE AUDIO.

**3** Press  STANDBY/ON on the DVD Receiver or ON on the remote controller.

The DVD Receiver turns on. The light and display on the DVD Receiver's front panel light. At the same time, the STANDBY indicator goes off.





The first time you turn on the DVD Receiver, the FIRST SETUP screen appears. In the FIRST SETUP screen, select the On-Screen Language and TV Shape according to the aspect ratio of the TV screen (see pages 52 and 53).

- 1 Press / to select "On-Screen Language," then press ENTER.
- 2 Select a language with /, then press ENTER.
- 3 Press  to select "TV Shape," then press ENTER.
- 4 Press / to select the aspect ratio of the TV screen, then press ENTER.
- 5 Finally press SETUP.

All of your selections are set and the FIRST SETUP screen disappears.

**Notes**

- To turn off the DVD Receiver, press  STANDBY/ON on the DVD Receiver, or STNBY  on the remote controller. The DVD Receiver enters standby mode. Be sure to set the volume to minimum before turning off the DVD Receiver.
- You can change the above settings later with "Customizing the Function Settings" on page 50.

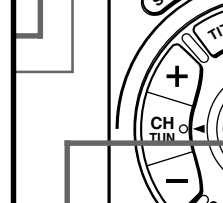
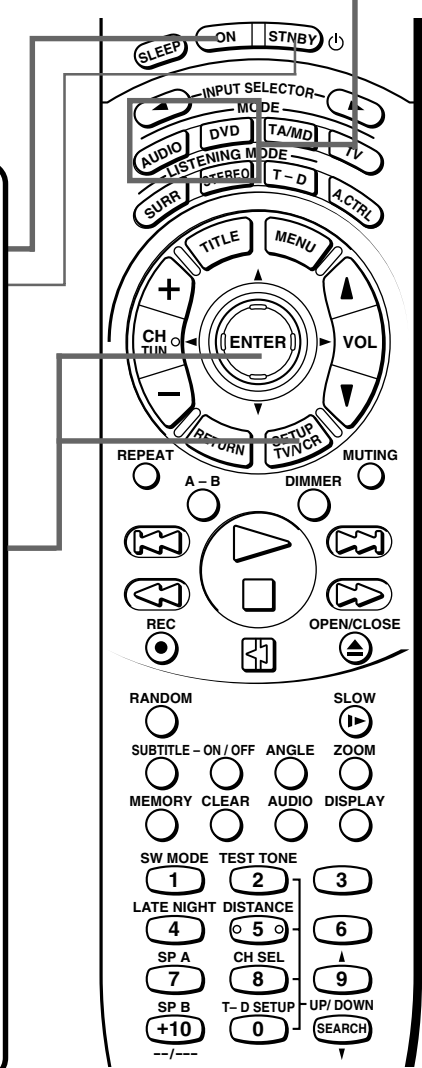

# Speaker Setup

You need to set up the speaker configuration for the speaker system connected to the **SPEAKERS A** connectors (see page 13.)

(There is no speaker configuration setup for the **SPEAKERS B** system.)

## Notes

- Speaker setup cannot be done if;
  - Headphones are connected (see page 31), or
  - The **SPEAKERS B** system is On (see page 30).
- It is not necessary to set the parameters again once you have completed the setup (with one exception\*) unless you change the speaker configuration.

\* See "To Listen to a High-Frequency/High-Quantization Format Source in its Original Sound Quality – 96k Sound" on page 46.

## Setting up the Speaker Configuration

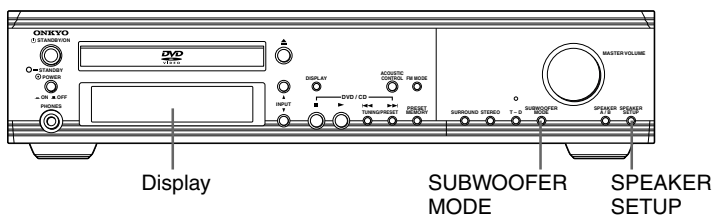

### Before operating the remote controller

Press **MODE AUDIO**.

The remote controller remains in the **AUDIO** mode, until another **MODE** button is pressed.



SW MODE

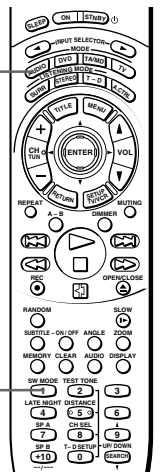

### ■ Selecting the number of speaker channels

Unit only

**SPEAKER SETUP**



Press **SPEAKER SETUP** repeatedly to select the number of channels for the **SPEAKERS A** system.

Speaker 3ch

With the first press of the button, you can check the present setting. Then each press of the button changes the number of channels as follows (the corresponding speaker configuration is described in parentheses):

- **Speaker 2ch**  
(Front left and right speakers)
- ↓
- Speaker 3ch**  
(Front left, center, and right speakers)
- ↓
- Speaker 4ch**  
(Front left and right, plus surround left and right speakers)
- ↓
- Speaker 5ch**  
(Front left, center, and right, plus surround left and right speakers)

#### Note

The listening mode will automatically be set to "Stereo" (see page 36) once you set or reset the number of channels.

The normal display resumes in three seconds.

### ■ Setting the Subwoofer Mode

Unit

**SUBWOOFER MODE**



Remote controller

**SW MODE**



Press **SUBWOOFER MODE** on the unit or **SW MODE** on the remote controller.

SW Mode 2

With the first press of the button, you can check the present setting. Then each press of the button changes the subwoofer mode as follows (a tip on how to select the right subwoofer mode is in parentheses):

- **SW Mode 2**  
(When large-wideband-front speakers are connected)
- ↓
- SW Off**  
(When no subwoofer is connected)
- ↓
- SW Mode 1**  
(When small-with limited bass signal handling-front speakers are connected)

The normal display resumes in three seconds.

# Speaker Setup

## Setting the Distance From the Listening Position to Each Speaker

Before starting the procedure below, measure the distances from each speaker to the listening position.

For pair speakers such as front left and right speakers, the distance from the listening position to one speaker should be the same as the distance to the other.

In the procedure below, select the values which approximate the actual distances.

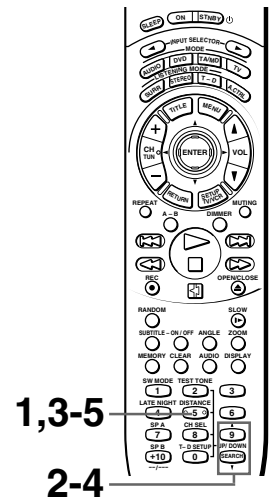

<p><b>1</b></p> <p>Remote controller only</p> <p><b>DISTANCE</b></p>	<p><b>Press DISTANCE.</b></p> <p>The distance entry display for the front left and right speakers appears.</p> <div style="border: 1px solid black; padding: 5px; text-align: center;"> <p>Front: 12 ft 3.6 m</p> </div>
<p><b>2</b></p>	<p><b>Press UP ▲/DOWN ▼ to select the front left and right speaker distance.</b></p> <div style="border: 1px solid black; padding: 5px; text-align: center;"> <p>Front: 14 ft 4.2 m</p> </div> <p>You can select a distance between 0.3 m and 9 m (1 ft. and 30 ft.).</p>
<p><b>3</b></p> <p><b>DISTANCE</b></p> <p>↓</p>	<p><b>Press DISTANCE, then press UP ▲/DOWN ▼ repeatedly to select the center speaker distance.</b></p> <div style="border: 1px solid black; padding: 5px; text-align: center;"> <p>Center: 11 ft 3.3 m</p> </div> <p>You cannot enter the following distances:</p> <ul style="list-style-type: none"> <li>Distances longer than the distance set for the front speakers.</li> <li>Distances shorter than the distance obtained by subtracting "1.5 m (5 ft.)" from the distance entered for the front speakers.</li> </ul> <p><b>Note</b></p> <p>If you selected a speaker configuration with no center speaker on the previous page, this step will be skipped.</p>

<p><b>4</b></p> <p><b>DISTANCE</b></p> <p>↓</p>	<p><b>Press DISTANCE, then press UP ▲/DOWN ▼ repeatedly to select the surround left and right speaker distance.</b></p> <div style="border: 1px solid black; padding: 5px; text-align: center;"> <p>Surround: 11 ft 3.3 m</p> </div> <p>You cannot enter the following distances:</p> <ul style="list-style-type: none"> <li>Distances longer than the distance set for the front speakers.</li> <li>Distances shorter than the distance obtained by subtracting "4.5 m (15 ft.)" from the distance entered for the front speakers.</li> </ul> <p><b>Note</b></p> <p>If you selected a speaker configuration with no surround speakers on the previous page, this step will be skipped.</p>
<p><b>5</b></p> <p><b>DISTANCE</b></p>	<p><b>Press DISTANCE.</b></p> <p>The normal display resumes.</p>

## Adjusting Each Speaker's Relative Volume Balance – Test Tone

Adjust each speaker's relative volume balance so that the volumes of all speakers' test tones sound equal at the listening position.

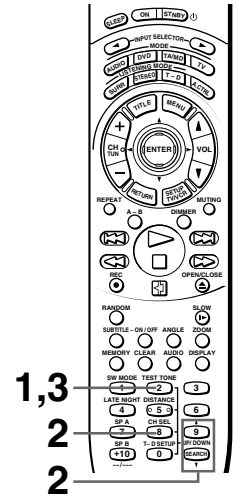

**1**

Remote controller only

TEST TONE



### Press TEST TONE.

Each speaker emits the test tone (pink noise) and the display shows the speaker emitting the test tone in the following order:

Left (Front left ch.)	→	Center (Center ch.)
↑		↓
Subwfr (Subwoofer)		Right (Front right ch.)
↑		↓
Surr L (Surround left ch.)	←	Surr R (Surround right ch.)

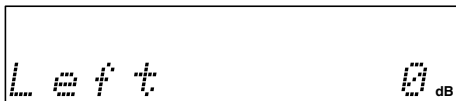

### Note

No test tone will be emitted from the speaker which is not included in the speaker configuration on page 17 even if it is actually connected.

**3**

TEST TONE



When you have completed the adjustment by repeating step 2, press TEST TONE.

The test tone stops and the normal display resumes.

### Note

Even if you don't press TEST TONE, the test tone will stop after 10 cycles.

**2**

CH SEL



UP/DOWN



Press CH SEL repeatedly to select the speaker, then press UP ▲ / DOWN ▼ to adjust the volume level.

The volume level can be adjusted between -12dB and +12dB.

# Playing DVD Videos / VIDEO CDs / Audio CDs

## Before playing

- DVD Videos, VIDEO CDs, and audio CDs can be played with the DVD Receiver (see "Playable Discs" on page 9). Do not play anything else.
- When playing DVD videos and VIDEO CDs, turn on the TV and set the TV to the DVD Receiver's input.

## About the DVD, VCD, and CD marks in the pages related to DVD video/VIDEO CD/audio CD operation

**DVD** means "The function or title is related to DVD operation."

**VCD** means "The function or title is related to VIDEO CD operation."

**CD** means "The function or title is related to audio CD operation."

### **DVD** If the screen on the right appears – Screen Saver

If you pause a picture for a long while, the screen saver operates. To resume normal display, press ►.

(You can set this function to Off. See page 55.)



### **DVD** To play NTSC discs (Multisystem TV is needed)

Set "PAL/Auto" to "Auto" using the menu explained in "Customizing the Function Settings" starting from page 50. See page 53 for direct information.

DVD, VCD, CD

## Basic Playback

### 1 Press ▲.

The disc tray opens.

If the DVD Player is in standby mode when the button is pressed

The DVD Player turns on and the disc tray opens. In this case, it takes several seconds until the disc tray opens.

### 2 Place the disc on the disc tray.

Put the disc in the tray with the label side facing up. There are two different disc sizes. Place the disc in the correct guide on the disc tray.

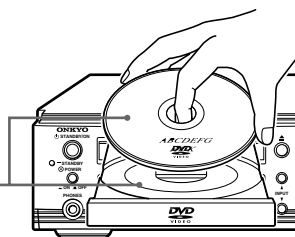

### CAUTION

Keep your fingers well clear of the disc tray as it is closing. Neglecting to do so may cause serious personal injury.

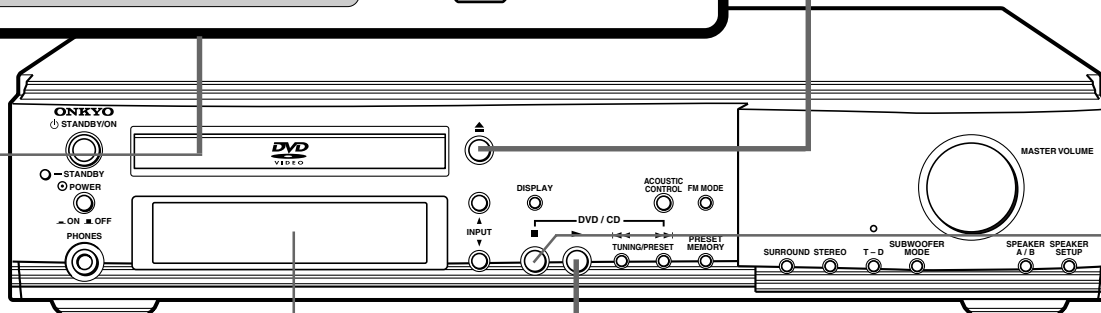

### 3 Press ►.

The disc tray closes and playback starts. If you press ▲ to close the tray after step 2, playback may automatically start depending on the disc.

One of the indicators, which indicate the digital sound format of the playing source, lights.

**DOLBY DIGITAL, DTS, MPEG (for MPEG2 sound), PCM (2 channel digital stereo)**

DOLBY DIGITAL DTS MPEG PCM

DVD

The type of the inserted disc lights. For the other information that appears in the display, see pages 48 and 49.

### **DVD** If a title menu appears on the TV screen

The DVD video has a title menu, or the VIDEO CD is equipped with the PBC (Playback Control) function. Follow steps 2 and 3 in "Locating a title using the title menu" on page 23.

For details about the PBC function, see "About VIDEO CDs" on page 9. To start playback with or without using the PBC function, see page 57.

### **DVD** If a sound selection menu appears on the TV screen

See "Enjoying the Sound Effects" on page 32 for details of the sound systems. Select the appropriate sound using ▲/▼/◀▶, then press ENTER (see the illustration of the remote controller on the opposite page).

For example, if you need to select either "DTS" or "Stereo," select "DTS" since the DVD Receiver is able to reproduce DTS (Digital Theater System) Surround sound.

### **CD** If the sound is not reproduced from the beginning of the disc

See the first note in the lower right corner of the opposite page.

**DVD** **Tip to obtain a higher quality picture**

Occasionally, some picture noise not usually visible during a normal broadcast may appear on the TV screen while playing a DVD video because the high resolution pictures on these discs include a lot of information. While the amount of noise depends on the TV you use, you should generally adjust the TV to reduce sharpness when viewing DVD videos.

**Before operating the remote controller**  
Press MODE DVD.



**■ To remove the disc**

DVD VCD CD

Press **▲** to open the disc tray.

Remove the disc after the disc tray opens completely. After removing the disc, be sure to press the button again to close the tray.

**■ To pause playback (still mode)**

DVD VCD CD

Press **⏸** (remote controller only) during playback.

To start playback, press **▶**.

**DVD** **To play frame by frame**

**VCD** Press **⏸** repeatedly during pause. Each time you press **⏸**, the picture advances one frame. To resume normal playback, press **▶**.

**Note**

The sound is muted during still mode and frame by frame playback.

**■ To stop playback**

DVD VCD CD

Press **■**.

When you press **▶** to restart playback, playback starts from the location where you stopped playback because the location index is stored in memory.

**Note**

The location where playback resumes may vary depending on the disc or the stopped scene.

**Resuming playback from the beginning**

Press **■** again after stopping playback to clear the location index memory, then press **▶** to start playback.

**DVD** Playback starts from the beginning of the current title.

To start playback from the beginning of the DVD video, open and close the disc tray (press **▲** twice), then press **▶** to start playback.

**VCD** Playback starts from the beginning of the disc.

**CD**

**Note**

The location index memory will also be cleared when:

- The power cord (mains lead) is unplugged,
- The DVD Receiver has entered standby mode,
- The disc tray is opened,
- The parental lock setting is changed (see page 56) or a disc menu language is selected (see page 52), or
- The other input source is selected.

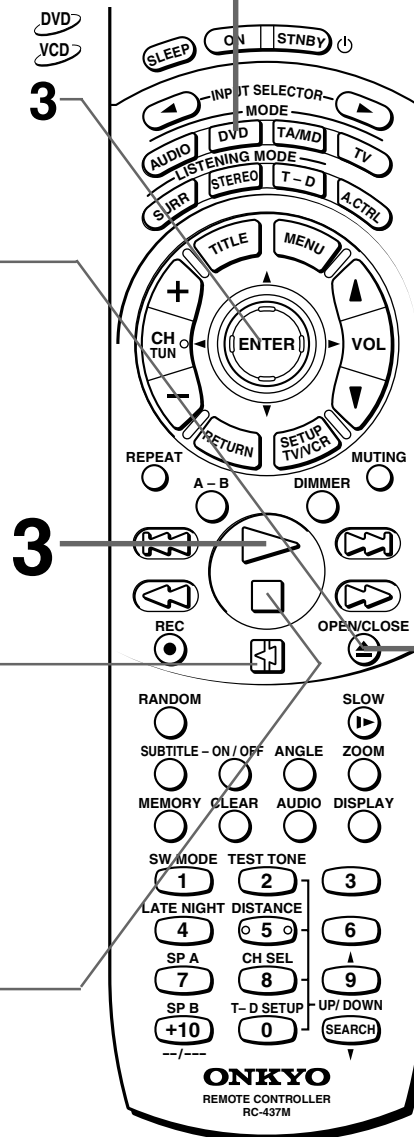

**Notes**

- When you start playing a CD, the sound may not be reproduced briefly while the DVD Receiver recognizes the sound system (DTS Surround or PCM). If this happens, stop playback by pressing **■** twice, then press **▶** to restart playback. The sound will be reproduced from the beginning of the disc.
- Do not move the DVD Receiver during playback. Doing so may damage the disc.
- Use **▲** on the remote controller or DVD Receiver to open and close the disc tray. Do not touch the disc tray while it is moving. Doing so may cause the DVD Receiver to malfunction.
- Do not press down on the disc tray or put any objects other than playable discs on the disc tray. Doing so may cause the DVD Receiver to malfunction.
- In many instances, a menu screen appears when playback of a movie is complete. Prolonged display of an on-screen menu may damage your television set, permanently etching that image onto its screen. To avoid this, be sure to press **■** once the movie is complete.

# Playing DVD Videos / VIDEO CDs / Audio CDs

## ■ To play in fast forward or fast reverse

DVD VCD CD

Press ►► (Fast Forward) or ◀◀ (Fast Reverse) during playback.

**DVD** The playback speed becomes two times the normal speed. Each press of the same button changes the playback speed as follows:

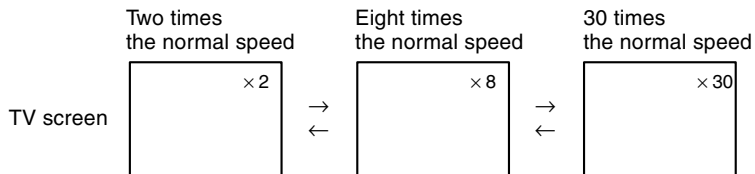

### Notes

- No sound is reproduced and no subtitles appear during fast forward or reverse playback.
- The x2, x8, and x30 speeds are only approximate speeds. These speeds may vary slightly from disc to disc.

**VCD** **CD** With each press of the same button, the playback speed alternates with the other as follows:

To check the marks on the right while playing a CD, turn on the TV and set the TV to the DVD Receiver's input.

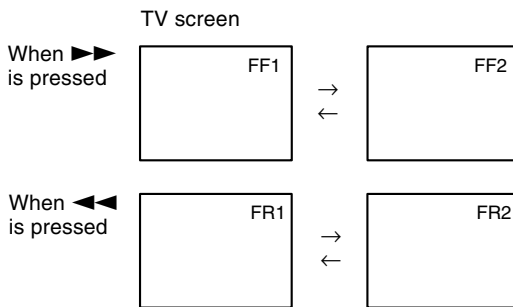

### Note

No sound is reproduced and no subtitles appear while playing back a VIDEO CD, whereas the sound is reproduced while playing back an audio CD.

To resume normal playback, press ►.

## ■ To play in slow-motion

DVD VCD

Press ► during playback.

Each press of the button changes the slow-motion speed as follows:

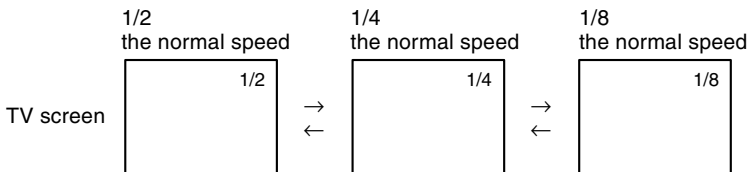

### Note

The sound is muted during slow-motion playback.

To resume normal playback, press ►.

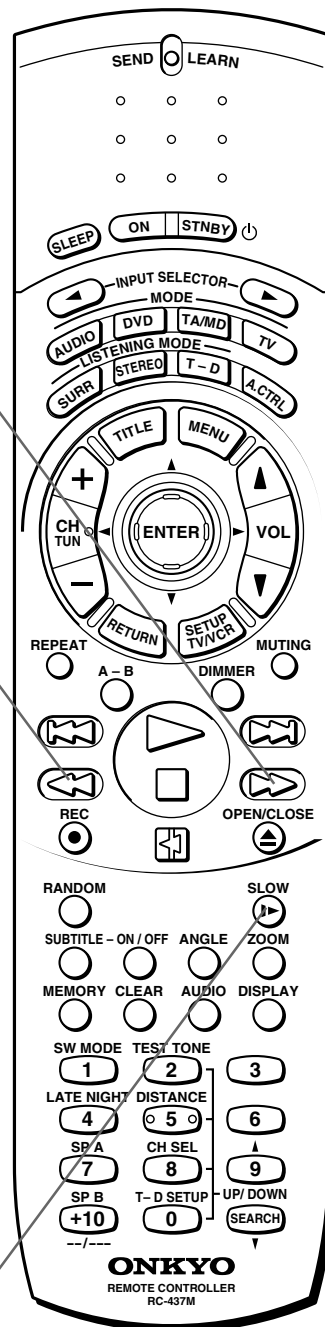

## Various Functions While Playing Discs

To use the following functions, see page 30.

- Turning on/off the SPEAKERS A/SPEAKERS B Systems
- Adjusting the Volume
- Muting the Sound
- Listening Through Headphones
- Controlling the Brightness of the Lights on the DVD Receiver
- Using the Sleep Timer

## Enjoying the Sound Effects

See page 32.

## Locating a Specific Title/Chapter/Track/Location

Normally, DVD videos are divided into titles, and the titles are subdivided into chapters. VIDEO CDs and audio CDs are divided into tracks.

**You can quickly locate any specific title, chapter, or track.**

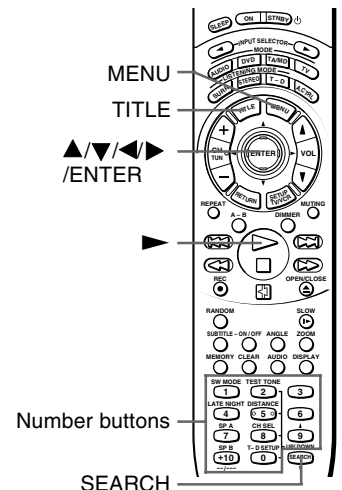
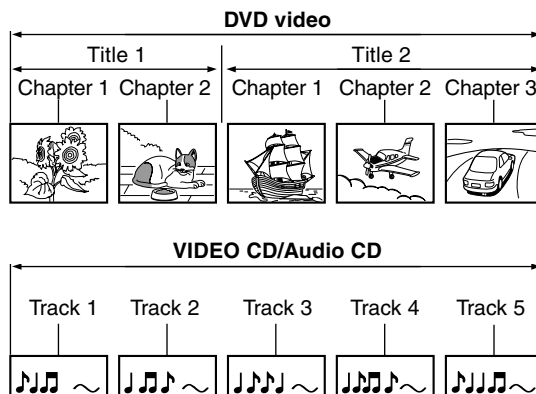

### Locating a title using the title menu

If a DVD video contains a title menu, you can locate a specific title using the title menu function.

### Locating a specific title and chapter by entering the numbers

If a DVD video contains the numbers corresponding to the titles and chapters, you can locate a specific chapter in a specific title directly by entering the numbers.

**1**  
Remote controller only



**Press TITLE. (Depending on the DVD video, press MENU.)**

The title menu appears on the TV screen.

Example of a title menu.

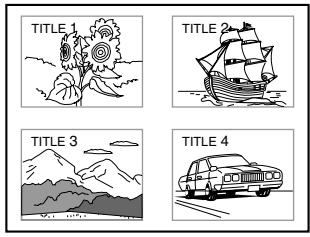

**2**



**Press ▲/▼/◀/▶ to select the title you want.**

If the titles in the title menu are assigned a number, you can also directly locate a specific title by entering its assigned number using the number buttons.

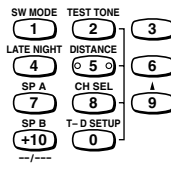

**3**



**Press ENTER.**

The DVD Receiver starts playback from chapter 1 of the selected title.

**1**  
Remote controller only



**Press SEARCH.**

Make sure that the number next to "Title:" is highlighted. (You can shift the highlight using ▲/▼.)

e.g.

Title: **1**

Chapter: 1

**2**

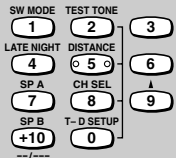

**Press the number button(s) to enter the title number for the desired title.**

e.g. To select title 2

Title: **2**

Chapter: 1

To select title 12

Title: **12**

Chapter: 1

If you do not need to change the chapter number appearing below the title number, skip steps 3 and 4 and go to step 5.

**3**



**Press ▼ to highlight the number next to "Chapter:."**

Title: 2

Chapter: **1**

- Notes**
- The instructions above describe basic procedures which may vary depending on the contents of the DVD video. If different instructions appear on the TV screen, follow those instructions.
  - If you display the title menu during playback and press TITLE again without selecting any title, the DVD Receiver usually resumes playback from the point where you first pressed TITLE. (There may be exceptional cases depending on the discs.)
  - This method of locating a title is available only on a disc that contains a title menu.
  - Instruction notes of discs may refer to the button that displays the title menu as "TOP MENU."

(Continued on next page.)

# Playing DVD Videos/VIDEO CDs/Audio CDs

**4**

Press the number button(s) to enter the chapter number for the desired chapter.

e.g. To select chapter 25



2 → 5

Title: 2  
Chapter: 25

**5**

Press ►.

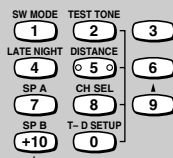
The DVD Receiver starts playback from the selected chapter in the selected title.

## Notes

- To enter a number between 10 and 99, you can also use (+10) (plus ten button) as follows:

+10 → +10 → 5

Title: 2  
Chapter: 25

- This location method is available only on a disc that contains the numbers corresponding to the titles and chapters.
- To cancel the entered title and chapter numbers, press CLEAR before pressing ►. The title and chapter numbers in step 1 will be displayed.
- To close the Title/Chapter display, press SEARCH several times (the number of times you press SEARCH varies depending on the disc).

## Locating a specific track directly

You can locate the desired track by entering the number.

**1**

Remote controller only

Press the number button(s) to enter the track number for the desired track.

e.g. To select track 25



2 → 5

Track : 25

**2**

Press ►.

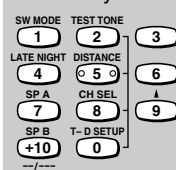
The DVD Receiver starts playback from the selected track.

## Notes

- To enter a number between 10 and 99, you can also use (+10) (plus ten button) as follows:

+10 → +10 → 5

Track : 25

- To cancel the entered track number, press CLEAR before pressing ►. The current track number will be displayed.



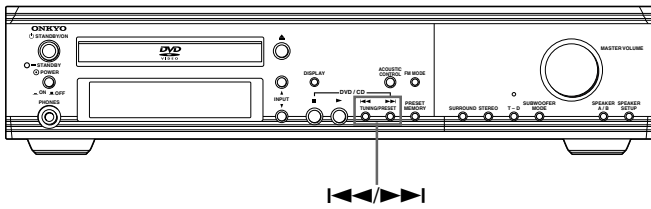







## ■ Locating a specific chapter or track consecutively

DVD  
VCD  
CD

You can locate consecutive chapters or tracks.

<p>Remote controller</p>  	<p><b>Press I◀◀ or ▶▶I (repeatedly) to select the chapter or track you wish to start playing</b></p> <p>Press I◀◀ once to start playback from the beginning of the current chapter or track.</p> <p>Press I◀◀ repeatedly to select the former chapters or tracks in reverse order.</p> <p>Press ▶▶I repeatedly to select the next chapter or track in order.</p>
<p>Unit</p>   <p>TUNING/PRESET</p>  	

### Notes

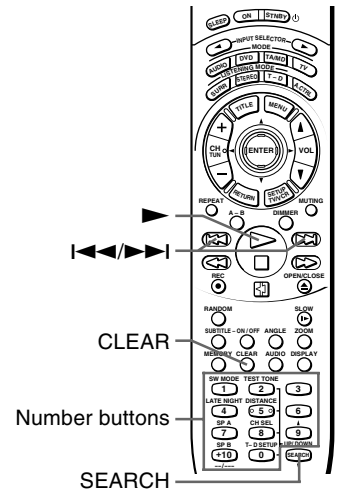

- Some title may not display chapter numbers.
- When you set "Title Stop" to "Off" (see page 57), you can locate consecutive chapters in another title. If you go back to the preceding title by pressing I◀◀, the DVD Receiver locates the first chapter of the title. When "Title Stop" is set to "On," you can locate consecutive chapters only within the current title.
- If you select the chapter or track during pause (while in still mode), you need to press ▶ to start playback.



## ■ Locating a specific location by entering the time

DVD  
VCD  
CD

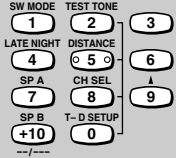
You can locate a specific location by entering its corresponding time (hours, minutes, and seconds).

<p><b>1</b></p> <p>Remote controller only</p> 	<p><b>Press SEARCH twice.</b></p> <p>You may need to press the button more than twice (depending on the disc) until the following display appears.</p> <div style="border: 1px solid black; padding: 5px; width: fit-content; margin: 10px auto;">             Time ■■■■■■           </div>
<p><b>2</b></p> 	<p><b>Press the number buttons to enter the location's time.</b></p> <p>The entered number appears on the right end of the field, then shifts to the left each time the next number is entered.</p> <p>e.g. (1) → (2) → (5) → (3) → (0)</p> <div style="display: flex; justify-content: space-around; margin: 10px 0;"> <span>Hours</span> <span>Minutes</span> <span>Seconds</span> </div> <div style="border: 1px solid black; padding: 5px; width: fit-content; margin: 10px auto;">             Time 1:25:30           </div> <p><b>Note</b></p> <p>If the location time you enter exceeds the total playing time of the disc, the setting will be cancelled.</p>
<p><b>3</b></p> 	<p><b>Press ▶.</b></p> <p>The DVD Receiver starts playback from the entered location.</p>

### Notes

- You can also use (+10) (plus ten button) to add ten to the hours, minutes, or seconds.
- Some discs may not respond to this procedure.
- Some scenes may not be located precisely.
- This method for accessing specific locations is available only within the current title of the DVD video or within the current track of the VIDEO CD/audio CD.

# Listening to the Radio

There are two ways to select radio stations:

- Manual tuning
- Presetting radio stations then selecting the preset channels

## Tuning Manually

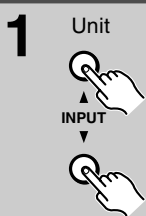
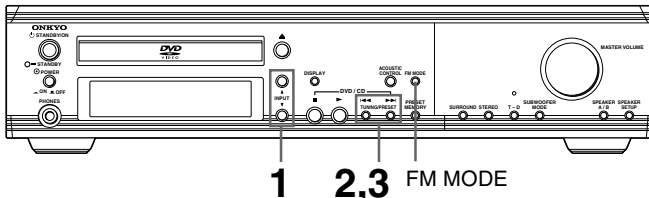

**Press INPUT ▲/▼ repeatedly to select the band (FM or AM).**

e.g. When FM is selected.



### Note

You can also select the band with the remote controller. See next page.

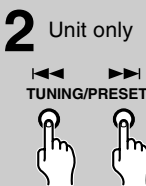

**Press and hold TUNING/PRESET ◀◀ or ▶▶ for about 1.5 seconds.**

Appears when a broadcast is received.

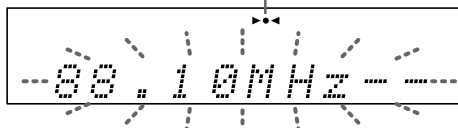

- **When the band is FM**  
Auto tuning starts. The frequency changes in 50 kHz steps.  
When a broadcast is received, scanning stops and the frequency flashes in the display.
- **When the band is AM**  
The frequency changes in 9 kHz steps.  
When you release the button, the frequency stops changing and flashes in the display.



**While the frequency is flashing (for about 5 seconds), press TUNING/PRESET ◀◀/▶▶ to change the frequency.**

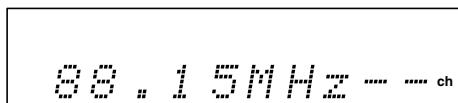

- The frequency changes in 50 kHz steps in FM and 9 kHz in AM each time you press TUNING/PRESET ◀◀ or ▶▶.
- You can change the frequency as long as the frequency in the display is flashing. Each press of either button causes the frequency to flash for about 5 seconds.

## Tuning in a weak frequency (only for FM stations)

When you tune in a stereo FM station, the FM ST indicator lights up if the signal is sufficiently strong.



If the signal is weak, you may not be able to tune to the station. In this case, **press FM MODE**. The FM MUTE indicator goes off. Then select the station to which you want to listen. (At this time, the station will be in mono and interstation noise will be heard.)

Unit Only  
FM MODE

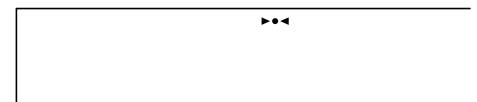

## Presetting Radio Stations

You can preset up to 30 stations.

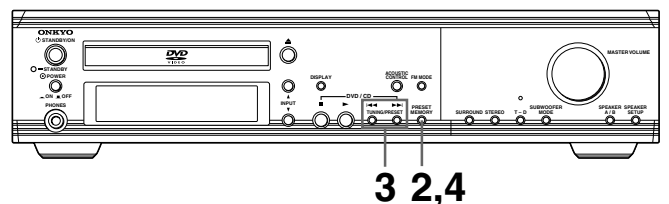

**Tune in the radio station you wish to preset (see steps in the left column of this page).**



**Press PRESET MEMORY.**  
The MEMORY indicator lights and the preset number starts flashing in the display.

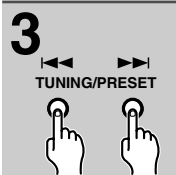

**While the MEMORY indicator is lit (for about 8 seconds), press TUNING/PRESET ◀◀/▶▶ to select the preset number.**



**Press PRESET MEMORY.**  
The radio station is registered to the preset channel.  
To register another preset station, repeat steps 1 to 4.

## Selecting Preset Stations

Before selecting preset stations, you need to preset the radio stations. See "Presetting Radio Stations" on the previous page.

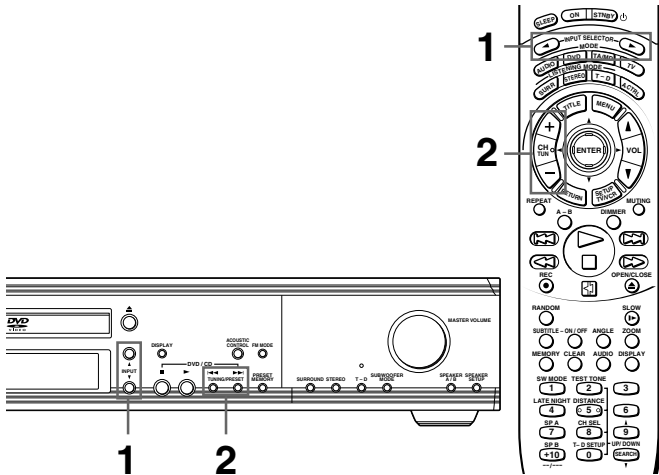

## Erasing a Preset Station

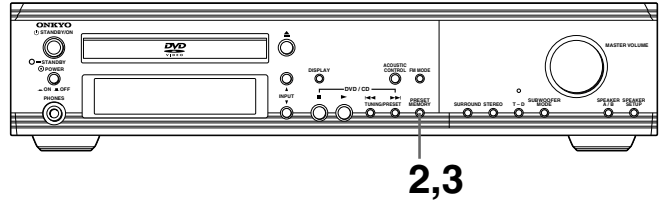

### 1 Remote controller

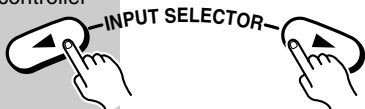

Press **INPUT SELECTOR** ◀▶ on the remote controller or **INPUT** ▲/▼ on the unit to switch the input source to the tuner.

"FM" or "AM" appears in the display. The band selected in this step will not affect the next step.



### 2 Remote controller



Press **CH TUN +/-** on the remote controller or **TUNING/PRESET** ◀◀▶▶ on the unit repeatedly to select the preset number of the desired radio station.



#### Notes

- If you press **TUNING/PRESET** ◀◀▶▶ on the unit for more than 1.5 seconds, the unit enters the manual tuning mode. See step 2 in "Tuning Manually" on the previous page.
- If you press **MODE TV** before pressing **CH TUN +/-**, the remote controller doesn't operate (see page 29). In this case, press another **MODE** button such as **MODE AUDIO**.

### 1

Select the preset channel you wish to erase (see steps in the left column of this page).

### 2 Unit only



Press **PRESET MEMORY**. "Erase?" appears in the display.

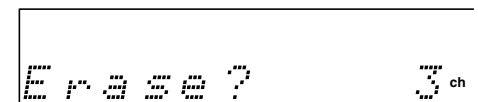

### 3



While "Erase?" is displayed (for about 8 seconds), press **PRESET MEMORY** again.

The selected preset channel will be erased.

## Receiving RDS

When an RDS (Radio Data System) station broadcasting PS (Program Service Name) information is received, the RDS indicator lights up and the name of the station is displayed. (RDS reception is only available in areas where RDS broadcasts are available.)



## Various Functions While Listening to Radio Programs

To use the following functions, see page 30.

- Turning on/off the **SPEAKERS A/SPEAKERS B** Systems
- Adjusting the Volume
- Muting the Sound
- Listening Through Headphones
- Controlling the Brightness of the Lights on the DVD Receiver
- Using the Sleep Timer

## Enjoying the Sound Effects While Listening to Radio Programs

See page 32.

# Playing the Connected Source

This section shows you how to play the sources connected to the DVD Receiver.

You may need to see "Connecting to a TV" on page 10 and "Connecting to Audio/Video Equipment" on page 11 while following the steps in this section.

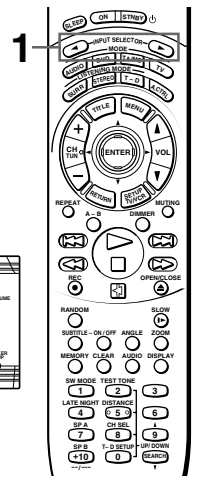
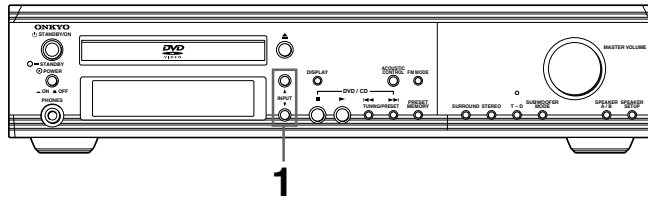

**1** Remote controller

**Unit**

**Press INPUT SELECTOR ◀/▶ on the remote controller or INPUT ▲/▼ on the unit to select one of the following input sources:**

- VIDEO 1
- VIDEO 2
- TV/LINE
- TAPE/MD

The selected input source appears in the multipurpose display. Also the input source indicator is lit in the display until the DVD Receiver is switched to another input source.

e.g. When VIDEO 1 is selected.

**2** Start playing the selected source.

## ■ About digital sound

If the equipment is digitally connected to the DVD Receiver, the sound from the digital input will automatically be selected and reproduced instead of the analog sound as explained below.

- When the VIDEO 1 source is selected, the digital sound from the VIDEO 1 DIGITAL INPUT (OPT) connector is reproduced.
- When the VIDEO 2 source is selected, the digital sound from the VIDEO 2 DIGITAL INPUT (COAX) connector is reproduced.

When the digital sound is reproduced, the DOLBY DIGITAL, DTS, or PCM (2 channel digital stereo) indicator lights up according to the received sound system in the DVD Receiver's display.

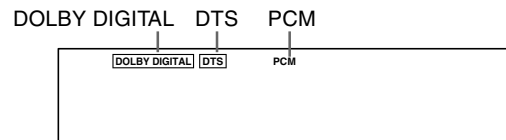

### Note

The DVD Receiver only reproduces DOLBY DIGITAL, DTS, and PCM sound formats from connected equipment.

## ■ Enjoying the picture with the sound of another source

Play the VIDEO 2 source and select TAPE/MD, FM, AM, or TV/LINE. Then you can enjoy the VIDEO 2 picture and the sound from the selected input source at the same time.

## Various Functions While Playing the Connected Source

To use the following functions, see page 30.

- Turning on/off the SPEAKERS A/SPEAKERS B Systems
- Adjusting the Volume
- Muting the Sound
- Listening Through Headphones
- Controlling the Brightness of the Lights on the DVD Receiver
- Using the Sleep Timer

## Enjoying the Sound Effects While Playing the Connected Source

See page 32.

# Operating the TV and Onkyo MD Recorder/Cassette Tape Deck With the Supplied Remote Controller

## ■ Operate your TV

First, let the remote controller learn the TV remote control signals (see page 61).  
Point the remote controller directly toward the TV when you want to operate this equipment.

Press MODE TV first.



You can program the TV remote control buttons' signals to the buttons shadowed in the illustration below.

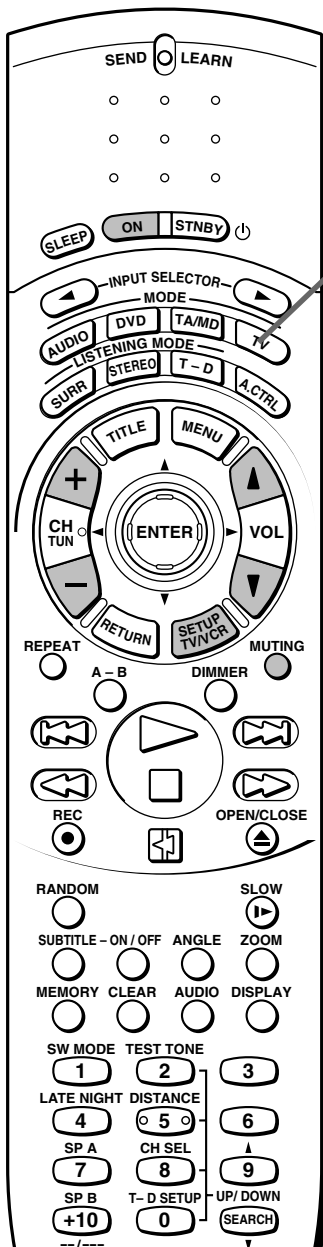

## ■ To operate the Onkyo MD recorder

No **RI** connection is needed.  
Point the remote controller directly toward the MD recorder when you want to operate this equipment.

## ■ Operating the Onkyo cassette tape deck

First, connect the cassette tape deck to the DVD Receiver with the **RI** cable (see page 15).  
Point the remote controller toward the DVD Receiver when you want to operate this equipment.

Press MODE TA/MD first.

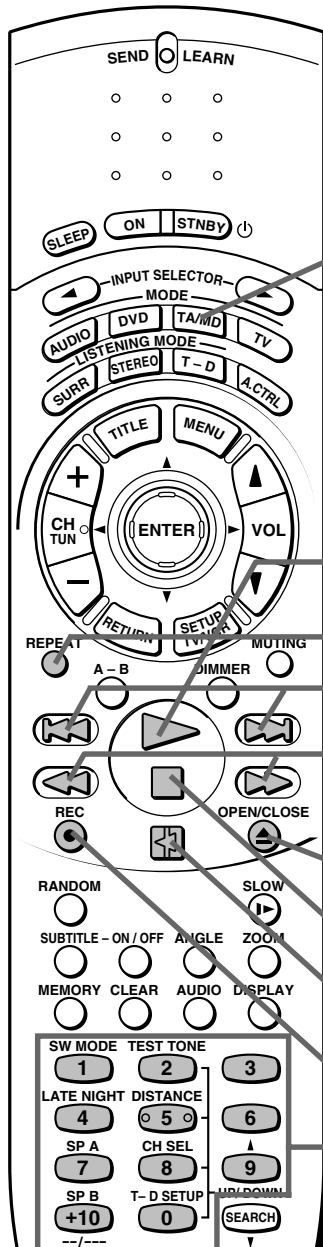

	MD recorder	Cassette tape deck
	Play	Play
REPEAT	Repeat mode	-
⏮ ⏭	Down Up	Rewind Fast forward
⏪ ⏩	Fast Reverse Fast Forward	- -
⏏	Eject	Open/Close the tray (This function is available only on some models.)
■	Stop/Cancel	Stop
⏸	Pause	Reverse play
● REC	Record	Record/ Recording pause
1-9, 0 +10 --/--	Number buttons	-

# Various Functions Common to all the Sources

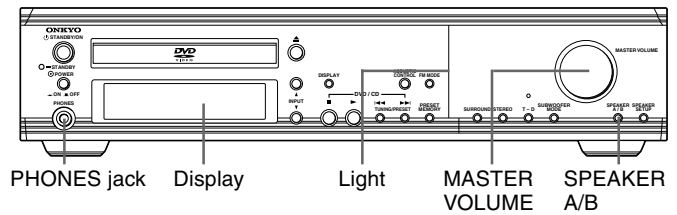

## Turning on/off the SPEAKERS A/ SPEAKERS B Systems

You can turn on or off the speaker systems connected to the SPEAKERS A and SPEAKERS B connectors individually.

### Note

If you turn on the SPEAKERS B system, the SPEAKERS A system also reproduces stereo sound automatically. (The listening mode is set to "Stereo." See page 36.)

Even if you turn off the SPEAKER B system later, the listening mode remains to "Stereo" until you select another listening mode.

The lit SP A and SP B indicators indicate the corresponding speaker systems are On.



### ■ Operating with the remote controller



Press **SP A** to turn on or off the **SPEAKERS A** system.



Press **SP B** to turn on or off the **SPEAKERS B** system.

### Note

It is impossible to turn off both speakers at the same time.

### ■ Operating with the unit



Press **SPEAKER A/B** repeatedly. Each press of the button changes the On/Off mode as follows:

- Only the **SPEAKERS A** system turns on.
- ↓
- Only the **SPEAKERS B** system turns on.
- ↓
- Both the **SPEAKERS A** and **B** systems turn on.

## Adjusting the Volume

The volume of the front left and right, center, surround left and right, and subwoofer speakers will be adjusted at the same time.

When headphones are connected (see next page), you can adjust the volume of the sound through the headphones.

### ■ Operating with the remote controller

Press **VOL ▲ / ▼**.



### ■ Operating with the unit

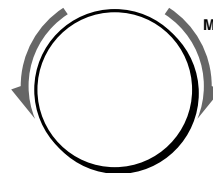

**MASTER VOLUME**

Turn **MASTER VOLUME** clockwise to increase the volume, or counterclockwise (anticlockwise) to decrease the volume.

## Muting the Sound

Remote controller only

**MUTING**



Press **MUTING**.

"Muting" appears in the multipurpose display for about three seconds. Also the **MUTING** indicator flashes in the display during the muting mode.

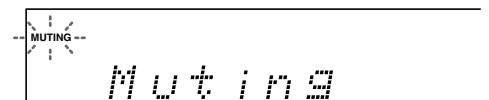

To restore the sound, press **MUTING** again.

### Tip

If you turn off the unit during muting, and turn it on again, the sound will be restored.

### Correlation between the MODE buttons and operation buttons explained on pages 30 and 31.

Operation buttons	MODE buttons			
	AUDIO	DVD	TA/MD	TV
SLEEP	×	×	×	—
VOL ▲/▼	×	×	×	*1
MUTING	×	×	×	*1
DIMMER	×	×	—	—
SP A	×	*2	*3	—
SP B	×	*2	*3	—

- × Operates the function explained on pages 30 and 31.
- Does not operate.
- \*1 If the button is programmed (see page 61), it operates the TV. If the button is not programmed, it doesn't operate.
- \*2 Functions as one of the number buttons to operate the built-in DVD player.
- \*3 Functions as one of the number buttons to operate the Onkyo MD recorder.

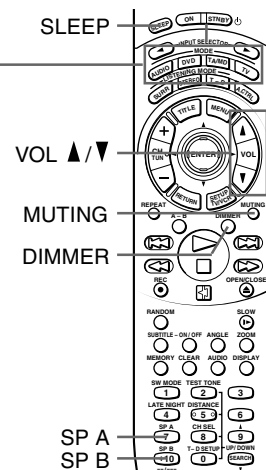

## Listening Through Headphones

Connect the plug of the stereo headphones to the PHONES jack on the DVD Receiver.

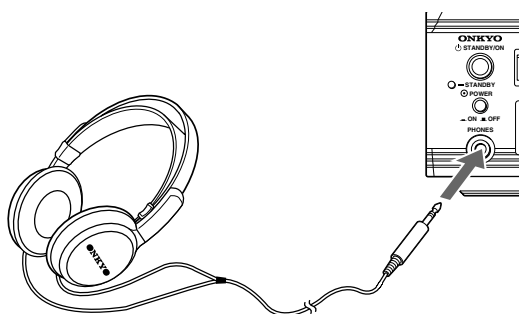

### Notes

- The speakers will not reproduce sound while headphones are connected.
- The listening mode is set to "Stereo" after connecting the headphones to the PHONES jack.
- When you disconnect the headphones, the listening mode returns to the previous mode.

## Using the Sleep Timer

Remote controller only



**Press SLEEP.**

"Sleep 90min" appears in the multipurpose display for about 5 seconds, which means the DVD Receiver will turn off and enter standby mode in 90 minutes. Also the SLEEP indicator is lit in the display while the sleep timer is On.

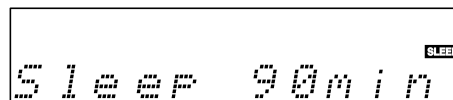

Each press of the button makes the remaining time shorter by 10 minutes.

### ■ Checking the remaining time

**Press SLEEP while the Sleep Timer is On.**

If you press SLEEP while the remaining time is displayed, the remaining time is reduced by 10 minutes.

### ■ Canceling the Sleep Timer

**Press SLEEP repeatedly until the SLEEP indicator goes off.**

## Controlling the Brightness of the Lights on the DVD Receiver

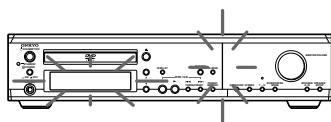

Remote controller only  
**DIMMER**



**Press DIMMER.**

Each press of the button changes the brightness as follows:

→ The display becomes less bright.

↓  
The display is dimmed.

↓  
The display is dimmed, and the light on the DVD Receiver's front panel goes off (see page 16).

↓  
The display resumes the original brightness and the light on the DVD Receiver's front panel turns on.

# Enjoying the Sound Effects

The surround sound of the DVD Receiver enables you to enjoy the presence of a movie theater or concert hall in your room. Before using any sound effect, make sure the Speaker Setup configurations have been set (see page 17).

The speaker configuration is very important for the surround sound. See "Connecting Speakers" on page 13 and "Positioning Speakers" on page 12.

Following are the sound systems the DVD Receiver can reproduce.

## ■ DOLBY DIGITAL Surround and DTS (Digital Theater System) Surround

### Minimum required speaker system

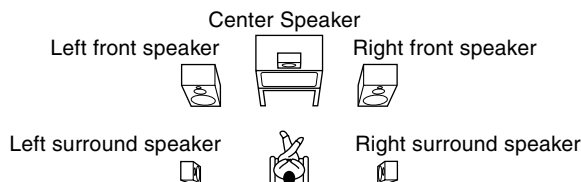

This 5.1 channel digital surround format enables you to individually play five full-range (20Hz-20kHz) channels (left and right front, center, and two surround channels) plus an LFE (Low Frequency Effect) channel for the low-range effect sound. It will create a realistic sound like that heard in theaters and concert halls.

### DOLBY DIGITAL Surround

DVD videos that have the  mark are recorded using this system.

To playback DOLBY DIGITAL Surround sound from connected equipment, you must make the digital connection in addition to the above speaker configuration.

### DTS Surround

DVD videos and audio CDs that have the  mark are recorded using this system.

To playback DTS Surround sound from connected equipment such as an LD player, you must make the digital connection in addition to the above speaker configuration.

### Notes on DTS Surround

- If you play a DTS Surround encoded disc with the DVD Receiver, or a DTS encoded disc using a digitally connected player, you may hear a noise for a short while until the DTS decoder of the DVD Receiver recognizes the DTS encoded signal and starts operating. This is not a malfunction.
- If you play a DTS Surround source in fast reverse or fast forward, pause, or skip a chapter or track, noise may be heard. This is not a malfunction.
- Even when playback of the DTS Surround source stops and the DTS signal transmission ends, the DVD Receiver remains in DTS mode and the DTS indicator remains lit. This is to prevent noise when you pause, fast forward, fast reverse, or skip a chapter or track of the playback source. Therefore, if the source switches from the DTS signal to a PCM (2 channel digital stereo) signal immediately, the PCM signal may not be played. In such a case, stop playback for about three seconds, then resume playback.
- Some CD players (if connected to the DVD Receiver) and LD players may be unable to play DTS Surround sources correctly even if you connect the player to the DVD Receiver digitally. In such a case, the digital signals (such as the output level, sampling frequency, frequency response, etc.) processed by the player cannot be recognized as DTS data by the DVD Receiver and you may hear noise instead of the proper sound.

## ■ DOLBY PRO LOGIC Surround

This surround format consists of four channels (left and right front, center, and monaural surround channel). This format is very effective for panning music, conversation, and three-dimensional sound movement output from three front channels. It also simulates the atmosphere and surround effects of the sound reflected from the side and rear walls of the theater.

VHS video cassettes, VHS Hi-Fi video cassettes, LDs, and DVD videos that have the  mark are suitable sources for this listening mode.

## ■ Onkyo's original Digital Signal Processing (DSP) modes

The DVD Receiver offers the following special Onkyo sound effects for sources other than Dolby Digital and DTS sounds.

### Orchestra

This mode is suitable for classical and opera music. The center channel is cut and the surround channels are emphasized to widen the stereo image. It simulates a natural reverberation as created in a large hall.

### Unplugged

This mode is suitable for acoustic instrumental sounds, vocals, and jazz music. By emphasizing the front stereo image, it simulates the acoustics in front of the stage.

### Studio-Mix

This mode is suitable for rock and popular music. Lively sounds with a powerful acoustic image will make you feel as if you are in a club.

### TV Logic

This mode offers the realistic acoustics of a TV program being aired in the TV studio. It enhances the entire surround sound and clarity of conversation.

### All Ch Stereo

This mode is useful for background music. The front and surround channels will create a stereo image.



## ■ Theater-Dimensional (T-D)\* mode Theater-Dimensional

The ideal home theater is realized by the multichannel sound reproduction with the complete speaker configuration and speaker positioning described on page 12. However, sometimes it is difficult to meet all those conditions. In reality, you may only have front speakers, or not be able to place the surround speakers in position.

Even if your speaker system is not complete, you can enjoy the multichannel surround sound by using the Theater-Dimensional mode. Theater-Dimensional mode sets the output channels to generate the most suitable virtual surround reproduction according to the number of the speaker channels set in "Speaker Setup" on page 17.

### The importance of the speaker setup

Calibrating each speaker's sound pressure is essential for home theater sound reproduction. The same thing can be said for virtual surround sound reproduction. Especially level matching and the time alignment of the two speakers that reproduce virtual surround signals becomes an even more important factor than with normal multichannel reproduction.

For the DVD Receiver, the calibration for the multichannel reproduction (see speaker distance setting on page 18 and test tone adjustment on page 19) provides the most appropriate level matching.

#### Notes

- For the input sources which include the surround channel signals like the multichannel DOLBY DIGITAL and DTS surround sounds, the virtual processing is applied to those surround channel signals.
- For the 2 channel input sources, the surround channel elements are automatically extracted with the DOLBY PRO LOGIC processing before the virtual processing is applied.
- For the monaural or front 3 channel stereo sources, the virtual surround effect does not work since those input sources do not include the surround channel signals.

\* Theater-Dimensional is a virtual surround technology developed by Onkyo. This technology is approved by Dolby Laboratories for the virtual surround processing of the Virtual Dolby Digital and Virtual Dolby Surround products.

## The Input Sources and Available Listening Modes

The available listening modes varies depending on the sound type of the input source. The table below shows the correlation between the input source types and listening modes.

(× marked listening modes can be chosen with a particular type of a source.)



Input Source Signals → Possible sources → Listening Modes ↓	Analog/PCM	Dolby Digital	DTS
	Audio cassette, audio CD, VIDEO CD, Record, FM broadcast, AM broadcast	DVD video, LD, Digital (satellite) broadcast	DVD video, audio CD, LD
Stereo	×	×	×
Theater-Dimensional	×	×	×
DOLBY DIGITAL		×	
DTS			×
DOLBY PRO LOGIC/ 3 Stereo*	×		
Orchestra	×		
Unplugged	×		
Studio-Mix	×		
TV Logic	×		
All Ch Stereo	×		

\* See "Using Dolby Pro Logic/Onkyo's Original DSP Modes" on page 36.

#### Notes

- To reproduce MPEG2 sounds from a DVD video, you need to change the sound conversion method to "96k Sound" or "PCM." See "Reproducing MPEG2 Sounds from DVD Videos" on page 47.
  - If you set the sound conversion method to "96k Sound," then the listening mode is set to "Stereo."
  - If you set the sound conversion method to "PCM," then you can choose the same listening modes as "Analog/PCM" in the above table.
- The listening mode is set to "Stereo" when the PCM sound whose sampling frequency is higher than 48kHz is played. Such high-resolution sounds are reproduced from sources such as DVD video.
- If you wish to set the listening mode to "Stereo" when playing DTS sources, select "Speaker 2ch" by repeating the procedure in "Selecting the number of speaker channels" on page 17. If any setting other than "Speaker 2ch" is selected, some sources may not reproduce desirable sound.

## Checking the Sound System of the Playing Source

The DVD Receiver will automatically detect the sound system when DOLBY DIGITAL Surround (  ), DTS Surround (  ), MPEG (MPEG2 sounds from the built-in DVD player), or PCM DIGITAL (2 channel digital stereo) is played back. The corresponding sound system indicator lights in the DVD Receiver's display.

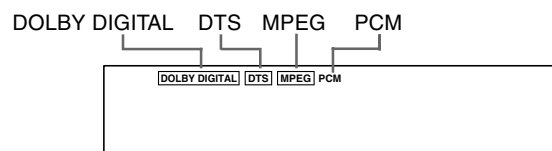

# Enjoying the Sound Effects

## Choosing Theater-Dimensional Mode

Theater-Dimensional mode is the technology which controls the characteristics of the sounds reaching the listener's left and right ears, therefore, there is a sweet spot where you can best experience the Theater-Dimensional effects. You need to adjust the location of the sweet spot and these other factors for the best possible Theater-Dimensional effect.

### ■ Listening angle

("Lisng. Angle" appears in the display.)

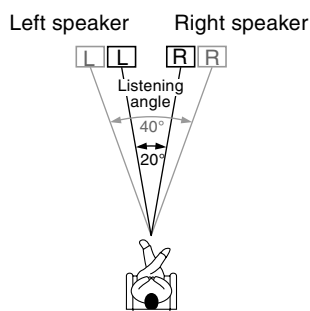

The longer the distance between the two speakers is, the wider the angle is.

The listening angle is the angle at the listening position where the two lines from the left and right speakers meet.

You need to adjust the listening angle in the following cases:

- If you set "Speaker 2ch" or "Speaker 3ch" in "Speaker Setup" on page 17. Consider the listening angle as being formed from the left and right front speakers since the virtual surround signals are output from the front speakers.
- If you cannot place the surround speakers in the correct position.
  - Place each surround speaker on top of or on the outer side of each front speaker of the same side.
  - Consider the listening angle as being formed from the left and right surround speakers since the virtual surround signals are output from the surround speakers.

Set "**Lisng. Angle**" to one of the following settings, which you feel is most effective (the listening angles in parentheses are the ideal degrees):

- **Normal** (30°)
- **Wide** (40°)
- **Narrow** (20°)

### ■ Corner mode

("Corner" appears in the display.)

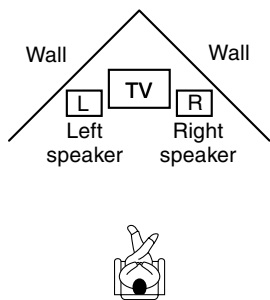

Theater-Dimensional controls the direct sounds from the speakers not the sounds reflected from the walls. Therefore, if the distances between the speakers and the walls are too short such as when the speaker system is placed in the corner of the room, and because of it, the reflected sounds reach the listener's ears too soon, the reflected sounds interfere with the virtual surround sounds.

In such a case, set "**Corner**" to "**On**," then the CORNER indicator lights up in the display. This may enhance the sound depending on the situation.

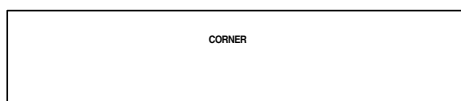

(The factory setting is "**Off**," which is the normal mode.)

#### Note

If the virtual surround sound is not enhanced with the corner mode, change the speaker positioning or cover the walls with acoustic materials.

### ■ Balance mode

("Balance" appears in the display.)

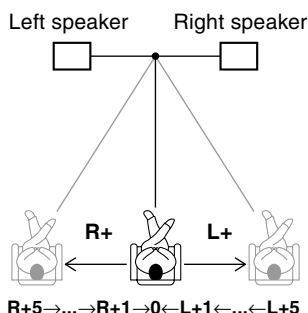

The listener should be on the center line between the left and right speakers. But if the situation does not allow you to sit in such an ideal position, you can adjust the balance.

Set "**Balance**" to one of the following 11 values, which you feel is most effective:

**R+5, R+4, R+3, R+2, R+1, 0, L+1, L+2, L+3, L+4, and L+5.**

The following tips may help you select the value:

- If the listener sits on the center line, then the factory setting "**0**" should be set as the balance, and
- If the listener sits on the right side of the center line towards the front speakers, select "**L+.**" If the listener sits on the left side, select "**R+.**" A larger value should be selected as the listening position becomes farther from the center line.

#### Notes

- The effect obtained with the balance adjustment may become less effective compared to the effect you obtain when you are actually on the center line.
- If the listening position is too far from the center line, the balance adjustment may not be able to correct the balance completely.

### ■ Dialog mode

("Dialog Mode" appears in the display.)

The dialog in the film may sound less clear because of the music or other sounds depending on the movie or scene.

In such a case, set "**Dialog**" to "**Enhance.**" (The factory setting is "**Normal**" which is the normal mode.)

#### Notes

- This function emphasizes the dialog in the center channel since the dialog sound, in most films, is allocated to the center channel. Therefore, if the dialog is not in the center channel, the sound will not be enhanced.
- Depending on the type of source, this mode is not very effective.

## ■ Activating Theater-Dimensional mode

See “The Input Sources and Available Listening Modes” on page 33.

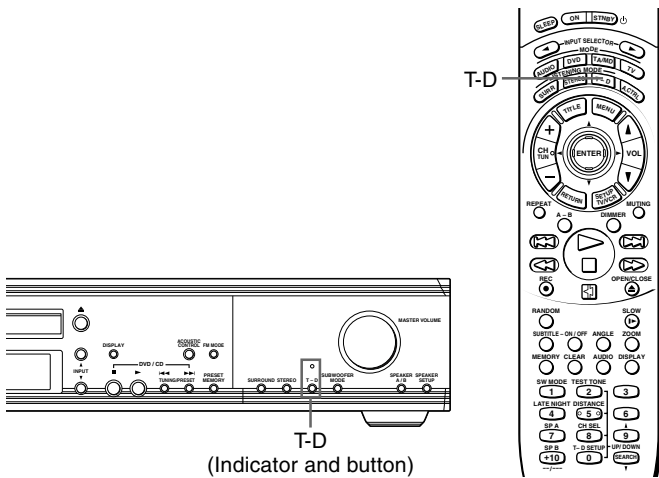

Remote controller

**Press T-D.**  
“Theater-Dimensional” scrolls across in the display and the Theater-Dimensional indicator on the unit lights.

The diagram illustrates the activation process. On the left, a hand presses the 'T-D' button on the remote. On the right, the unit's display shows 'Theater-Dim' and the 'T-D' indicator on the front panel is lit.

### Notes

- Theater-Dimensional mode cannot be activated if;
  - The sound is muted (see page 30),
  - Headphones are connected (see page 31),
  - SPEAKERS B system is On (see page 30), or
  - The source is PCM sound with a sampling frequency higher than 48kHz.
- Theater-Dimensional mode will be canceled and the Theater-Dimensional indicator goes off when:
  - Another listening mode is chosen (see page 36), or
  - The input source is switched to a type of source which Theater-Dimensional mode cannot process.

## ■ Adjusting Theater-Dimensional mode

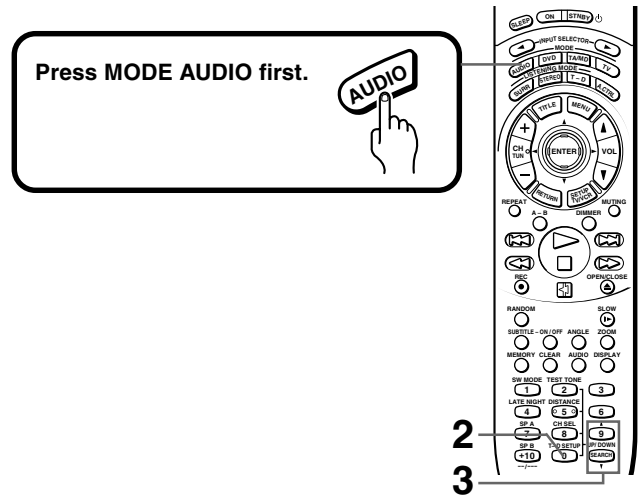

- 1** Activate Theater-Dimensional (see the steps in the left column of this page).
- 2** Remote controller only  
Press T-D SETUP repeatedly to select the Theater-Dimensional item (see on the previous page).

The diagram shows the remote control with the 'T-D SETUP' button highlighted. The unit's display shows 'Lisng. Angle'.

Each press of the button changes the item as follows:

  - Lisng. Angle
  - ↓ Corner
  - ↓ Balance
  - ↓ Dialog Mode
  - ↓ The normal display resumes.
- 3** Press UP ▲/DOWN ▼ to select the setting of the item.

  - To change the setting of another item, repeat steps 2 and 3.
  - To end the Theater-Dimensional setup, press T-D SETUP repeatedly until the normal display resumes.

The diagram shows the remote control with the '9' and 'SEARCH' buttons highlighted.

# Enjoying the Sound Effects

## Using Dolby Pro Logic/ Onkyo's Original DSP Modes

See "The Input Sources and Available Listening Modes" on page 33.

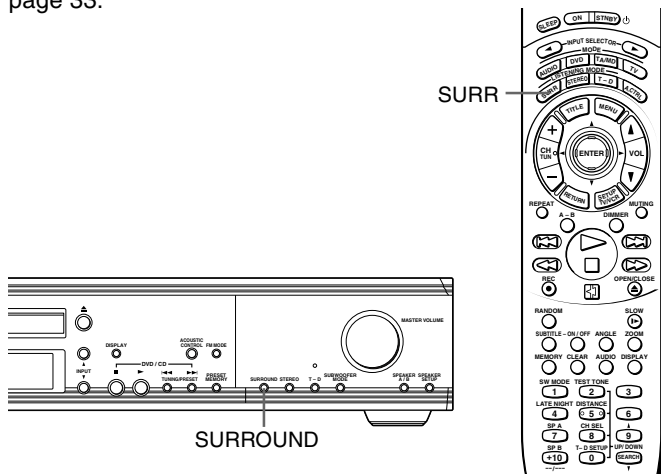

## Changing the Sound to Stereo

See "The Input Sources and Available Listening Modes" on page 33.

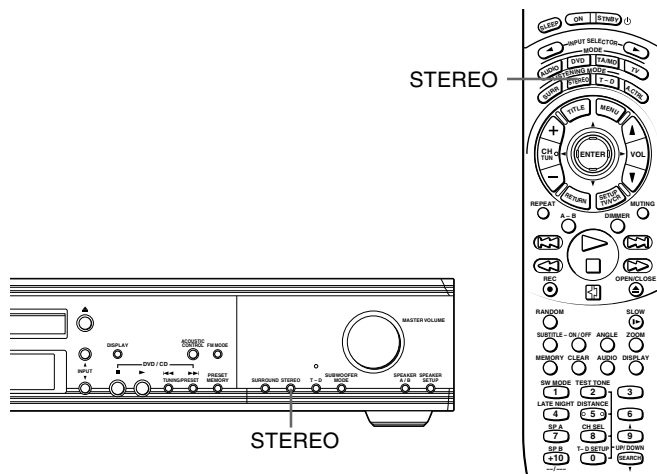

Remote controller



**Press SURRE on the remote controller or SURROUND on the unit to choose "Dolby Pro Logic" or the DSP mode.**

The current listening mode appears in the display when the button is pressed once, then each press of the button changes the listening mode as follows:

Dolby Pro Logic*	→	Orchestra
↑		↓
All Ch Stereo		Unplugged
↑		↓
TV Logic	←	Studio-Mix

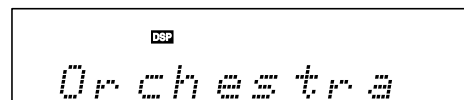

- \* – Suitable for Dolby Surround sources
- In the display, "Pro Logic" appears and the DOLBY PRO LOGIC indicator lights up.

DOLBY PRO LOGIC

- "3 Stereo" appears instead of "Pro Logic" if "Speaker 3ch" is selected on page 17. "3 Stereo" stands for DOLBY 3 STEREO.
- Skipped if "Speaker 2ch" is selected on page 17.

Remote controller



**Press STEREO.**

In the display, "Stereo" appears and the STEREO indicator lights up.

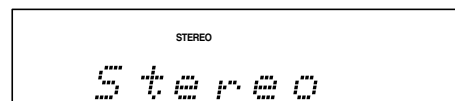

Unit

STEREO



### A tip to apply a DSP mode to the DOLBY DIGITAL Surround sound of a DVD video

You can change the format of the sound signal being output to the speakers and output jacks using the menu (see page 46). This means, for example, even if DOLBY DIGITAL Surround sound is played by the DVD Receiver, you can output sound to the speakers in the 48 kHz/16 bit format, which lets you to use the DSP sound effects instead of DOLBY DIGITAL Surround.

## Adjusting Each Speaker's Relative Volume Balance Temporarily

You can readjust each speaker's relative volume balance according to your preference while listening to the sound.

The adjusted values will return to the values set on page 19 when the DVD Receiver enters standby mode, or the main power is switched off unless you save the values.

Press **MODE AUDIO** first.

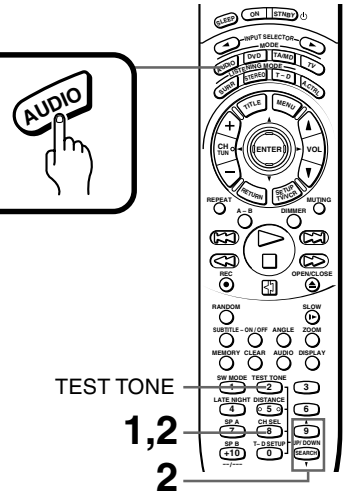

TEST TONE  
1,2  
2

**1**

Remote controller only

CH SEL



**(Checking each speaker's relative volume balance)**

**While playing the source, press CH SEL repeatedly.**

Each press of the button changes the speaker which outputs the sound and the selected speaker appears in the display in the following order:

Left (Front left ch.)



Center (Center ch.)



Right (Front right ch.)



Surr R (Surround right ch.)



Surr L (Surround left ch.)



Subwfr (Subwoofer)



Speaker volume adjustment mode off



### Note

Any speaker that is not included in the speaker configuration on page 17 is not selected even if it is actually connected.

**2**

CH SEL



**(Adjusting each speaker's relative volume balance)**

Press **CH SEL** repeatedly to select the speaker, then press **UP ▲ / DOWN ▼** to adjust the volume level. The volume level can be adjusted between  $-12\text{dB}$  and  $+12\text{dB}$ .

Repeat this step to change another speaker's volume balance.

### ■ Saving the adjusted values

Remote controller only

Press **TEST TONE**.

TEST TONE



# Enjoying the Sound Effects

## Using the LATE NIGHT/FRONT EFFECT Function

- **The LATE NIGHT function operates when the sound is DOLBY DIGITAL Surround.**  
If you play a movie at low volume at night, set this function to "Low" or "High" to narrow the dynamic range of the sound and make it easier to hear.
- **The FRONT EFFECT function operates with DSP modes other than All Ch Stereo.**  
If you use one of the DSP sound effects with a source containing acoustic reverberation, the sound may become unclear because of too much reverberation. In such case, set this function to "Off." The DSP sound effect will not add additional reverberation to the sound output to the three front speakers.

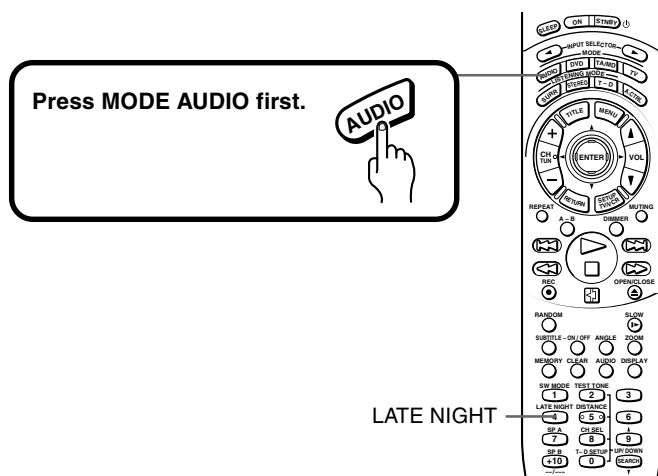

**Press LATE NIGHT.**  
The current setting appears in the display. To change the setting, press the button repeatedly while the current setting is displayed.

- **When the button is pressed while DOLBY DIGITAL Surround sound is being reproduced**  
"L-Night Low," "L-Night High," or "L-Night Off" can be selected.



- **When the button is pressed while one of the DSP sound effects is being used**  
"F-Effect Off" or "F-Effect On" can be selected.



**Note**  
The LATE NIGHT effect is determined by each DOLBY DIGITAL sound source. Some sources may produce little or no effect.

## Boosting the Super Bass Sounds/High Frequency Sounds

You can enjoy more dynamic sounds by boosting the super bass/high frequency sounds, even with decreased volume.

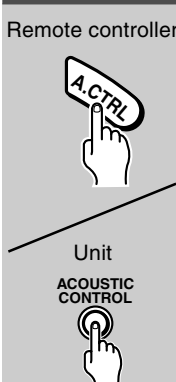
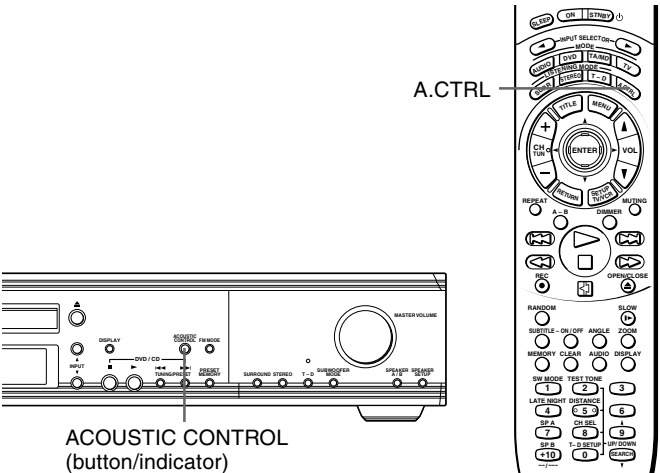

**Press A.CTRL on the remote controller or ACOUSTIC CONTROL on the unit.**

Each press of the button changes the acoustic mode as follows:

- "A. Ctrl 1" appears in the display and the ACOUSTIC CONTROL indicator on the unit lights in orange. The super bass sounds are boosted.
- ↓ "A. Ctrl 2" appears in the display and the ACOUSTIC CONTROL indicator on the unit lights in green. The super bass sounds are further reinforced and the high frequency sounds are also reinforced.
- ↓ "A. Ctrl Off" appears in the display and the ACOUSTIC CONTROL indicator goes off.



# Playing Repeatedly

You can play a specific title, chapter, track, or segment repeatedly (Title repeat, chapter/track repeat, A-B repeat).

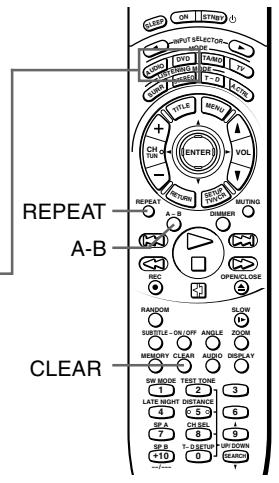
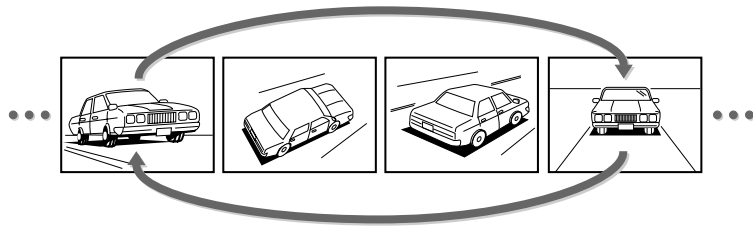

DVD VCD CD

## Repeating a Title, Chapter, or Track

You can play the same title, chapter, or track repeatedly (Title, chapter/track repeat).

<b>1</b>	<b>Select the title, chapter, or track you want to repeat. (See pages 23 to 25.)</b>												
<b>2</b> Remote controller only <b>REPEAT</b> 	<p><b>Press REPEAT.</b></p> <p>The REPEAT indicator lights up in the DVD Receiver's display.</p> <p>Each time you press REPEAT, the repeat mode and its display on the TV screen changes as follows.</p> <div style="margin-left: 20px;"> <p><b>DVD</b></p> <table border="1"> <tr> <td>Chapter Repeat</td> <td>Repeats the same chapter.</td> </tr> <tr> <td>Title Repeat</td> <td>Repeats the same title.</td> </tr> <tr> <td>Repeat Off</td> <td>Resumes normal playback.</td> </tr> </table> <p><b>VCD CD</b></p> <table border="1"> <tr> <td>Track Repeat</td> <td>Repeats the same track.</td> </tr> <tr> <td>All Repeat</td> <td>Repeats the entire disc.</td> </tr> <tr> <td>Repeat Off</td> <td>Resumes normal playback.</td> </tr> </table> </div>	Chapter Repeat	Repeats the same chapter.	Title Repeat	Repeats the same title.	Repeat Off	Resumes normal playback.	Track Repeat	Repeats the same track.	All Repeat	Repeats the entire disc.	Repeat Off	Resumes normal playback.
Chapter Repeat	Repeats the same chapter.												
Title Repeat	Repeats the same title.												
Repeat Off	Resumes normal playback.												
Track Repeat	Repeats the same track.												
All Repeat	Repeats the entire disc.												
Repeat Off	Resumes normal playback.												

DVD VCD CD

## Repeating a Specific Segment

You can play a specific segment repeatedly (A-B repeat).

<b>1</b> Remote controller only <b>A - B</b> 	<p><b>Press A-B at the beginning of the segment (point A) you want to play repeatedly.</b></p> <p>The A point is fixed.</p> <p>"A" flashes on the TV screen, and the A-B REPEAT indicator lights up in DVD Receiver's display.</p> <div style="margin-left: 20px;"> <table border="1"> <tr> <td style="text-align: center;">A-</td> </tr> </table> </div>	A-
A-		
<b>2</b> <b>A - B</b> 	<p><b>Press A-B again at the end of the segment (point B).</b></p> <p>The B point is fixed.</p> <p>The DVD Receiver automatically returns to point A and starts repeat playback of the selected segment (A-B).</p> <p>"A-B" appears on the TV screen, and the A-B REPEAT indicator in the DVD Receiver's display remains lit.</p> <div style="margin-left: 20px;"> <table border="1"> <tr> <td style="text-align: center;">A-B</td> </tr> </table> </div>	A-B
A-B		

**■ To resume normal playback**

**CLEAR** **Press CLEAR.**

- Notes**
- Some discs may not permit A-B repeat operation.
  - You can play a specific segment only within the current title or track.
  - You cannot set the A-B repeat function for segments that include multiple camera angles.
  - There may be a slight difference between the A point and the location where playback actually resumes depending on the disc.

**■ To resume normal playback**

**CLEAR** **Press CLEAR.**

**Note**  
Some discs may not permit repeat operation.

# Playing in a Favorite Order

You can combine your favorite titles, chapters, or tracks and play them in any order. You can program up to 28 selections into the memory (Memory playback).

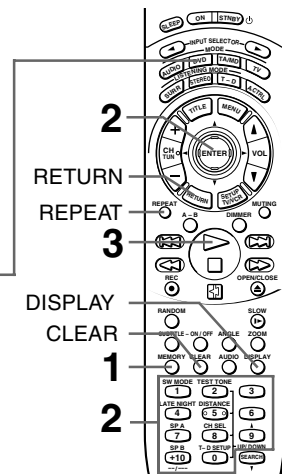

DVD VCD CD

## Setting Titles, Chapters, or Tracks in a Favorite Order

The DVD Receiver automatically plays titles, chapters, or tracks in the order you program.

**1** Remote controller only  
**MEMORY**

**Insert a disc and press MEMORY while the disc is stopped.**

The following display appears on the TV screen, and the MEMORY indicator flashes in the DVD Receiver's display.

MEMORY			
T	C	T	C
1	---	---	---
2	---	---	---
3	---	---	---
4	---	---	---
5	---	---	---
6	---	---	---
7	---	---	---

DVD VCD CD

T: Title number  
C: Chapter number

T: Track number  
C: Ignored even if a number is entered.

VCD CD

**Press the number button(s) to select the track number, then press ENTER to confirm.**

Repeat this step to select the next track.

**3**

**While the MEMORY display is displayed, press ►.**

The DVD Receiver starts memory playback.

The MEMORY indicator in the DVD Receiver's display lights steadily.

**2**

**1 Press the number button(s) to enter the title number.**

**2 Press ► to highlight "--" below C.**

**3 Press the number button(s) to enter the chapter number.**

**4 Press ENTER to confirm.**

**To select another chapter in the same title**  
Press the number button(s) for another chapter.

**To select another title**  
Press ◀ to highlight the next "--" below T, then repeat the above steps.

e.g. To play chapter 25 in title 2, chapter 12 in title 2, all the chapters in title 1, and chapter 2 in title 4.

Title number Chapter number

Memory 1 2 → ENTER → 2 → 5 → ENTER

Memory 2 1 → 2 → ENTER

Memory 3 ENTER → 1 → ENTER

Memory 4 4 → ENTER → 2 → ENTER

MEMORY			
T	C	T	C
1	02	25	8
2	02	12	9
3	01	---	---
4	04	02	11
5	---	---	---
6	---	---	---
7	---	---	---

### ■ To change or cancel the entered program

While the MEMORY display is displayed, press ▲/▼ to highlight the item.

- To select another title/chapter or track follow step 2.
- To cancel, press CLEAR.

### ■ To resume normal playback

Press CLEAR.

### ■ To program during playback

If you press MEMORY during playback, the display to accept your programming appears.

To display the MEMORY display, press DISPLAY, then follow steps 2 and 3.

### Notes

- You can also use (+10) (plus ten button) to add ten to the number.
- Some discs may not permit memory playback operation.
- If you press REPEAT during memory playback, the DVD Receiver repeats the current memory playback.
- Although you can select title, chapter, and track numbers not included on the disc, those numbers are ignored.
- If you press MEMORY or RETURN while the MEMORY display is displayed, the MEMORY display disappears.
- The programmed selections will be cleared when you turn off the DVD Receiver.



# Playing in Random Order

You can play chapters, titles, or tracks, or chapters within a title, in random order (Random playback).

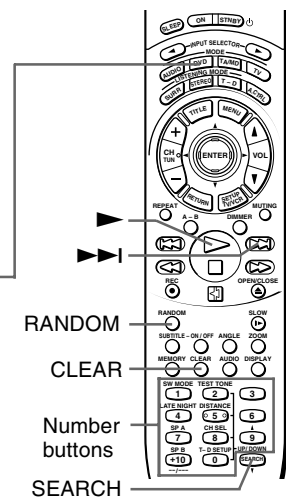
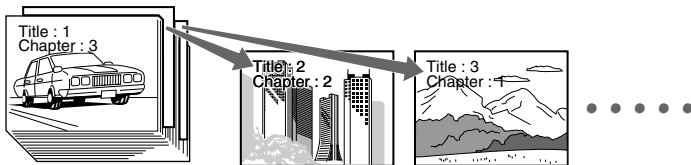

DVD VCD CD

## Playing Chapters, Titles, or Tracks in a Disc in Random Order

The DVD Receiver automatically selects the chapters or titles in a DVD video, or tracks in a VIDEO CD/audio CD, and plays them randomly.

**1** Remote controller only

**RANDOM**

**Press RANDOM twice while the disc is stopped.**  
Then, press RANDOM repeatedly to change the random play mode as follows:  
Chapter Random → Title Random  
Random off

Title Random

VCD CD

**Press RANDOM once while the disc is stopped.**  
To cancel random playback, press RANDOM again.

Track Random

Track : ■

If you press RANDOM during playback, the DVD Receiver automatically starts random playback after finishing the current chapter (when Chapter Random is selected), title (when Title Random is selected), or track.

---

**2** **Within 5 seconds, press ►.**  
The DVD Receiver starts random playback.

DVD

## Playing Chapters in a Selected Title in Random Order

The DVD Receiver automatically selects the chapters in a title and plays them randomly.

**1** Remote controller only

**SEARCH**

**Press SEARCH, then press the appropriate number button(s) for the title which contains the chapters you want to play in random order.**

e.g. To play the chapters in title 2 in random order

SEARCH → 2

Title: 2  
Chapter: 1

SW MODE TEST TONE 3  
1 2  
LATE NIGHT DISTANCE 6  
4 5  
SP A CH SEL 9  
7 8  
SP B T-D SETUP 0  
+10

---

**2** **RANDOM**

**Press RANDOM while the disc is stopped.**

Chapter Random

Title: 2  
Chapter: 1

If you press RANDOM during playback, the DVD Receiver automatically starts random playback after finishing the current chapter.

---

**3** **Within 5 seconds, press ►.**  
The DVD Receiver starts random playback.

### ■ To resume normal playback



### ■ To resume normal playback



#### Notes

- Some discs may not permit random playback operation.
- You cannot use the random playback function together with the memory playback function.
- If you press ►►I during random playback, the DVD Receiver goes to another chapter, title, or track and continues random playback.

#### Notes

- You can also use (+10) (plus ten button) to add ten to the number.
- Some discs may not permit random playback operation.
- You cannot use the random playback function together with the memory playback function.
- If you press ►►I during random playback, the DVD Receiver goes to another chapter and continues random playback.

# Zooming in on a Picture

You can magnify areas within a picture.

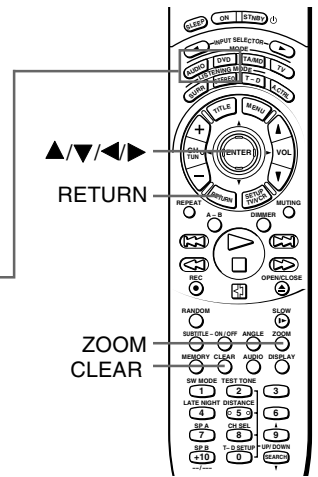
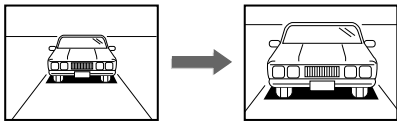

DVD

## Zooming in on a Picture and Shifting the Zoom Point

You can zoom in on a picture. You can also shift the zoom point.

Remote controller only

ZOOM



**Press ZOOM during normal, slow, or still playback.**

If you press ZOOM repeatedly, the magnification level increases.

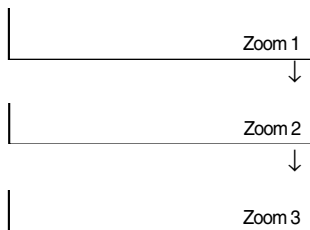

**To reduce the magnification level**  
Press RETURN.



**To shift the zoom point**

Press ▲/▼/◀/▶.

When the zoom point reaches an edge of the picture, the color of "Zoom" changes.



CLEAR



**To restore the original zoom point (center of the picture)**  
Press CLEAR.

### Notes

- Some discs may not permit zoom operation.
- During some scenes, the buttons may not work as explained in the step.
- Zooming does not work on subtitles or menu screens included on DVD videos.
- The magnification level varies depending on the picture size you select. (See pages 50 and 53.)

### ■ To resume normal playback

ZOOM



Press ZOOM repeatedly until "Zoom" disappears.

# Selecting the Camera Angle

You can select a preferred camera angle to watch a scene.

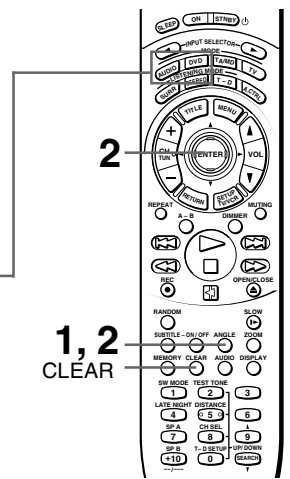
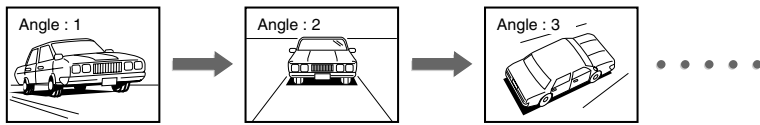

DVD

## Changing the Camera Angle

If the scene was recorded from multiple angles, you can easily change the camera angle of the scene you are watching.

1

Remote controller only

ANGLE



### Press ANGLE while playing a scene recorded with multiple angles.

While playing a scene recorded with multiple angles, the angle icon (⊞) appears on the TV screen and flashes in the DVD Receiver's display.

Press ANGLE while the angle icon is displayed.

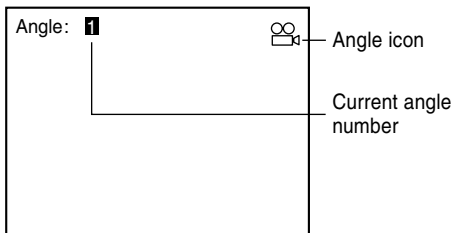

### ■ To turn off the angle number display

CLEAR



Press CLEAR.

### ■ To disable the angle icon display on the TV

Set "On-Screen Displays" to "Off" using the setting menu (see pages 50 and 55).

Monitor the DVD Receiver's display to check that the scene has multiple angles. The angle indicator (⊞) flashes in the DVD Receiver's display.



2

ANGLE



### Press ANGLE or ▲ while the angle number is displayed on the TV screen.

Each time you press ANGLE or ▲, the camera angle changes.

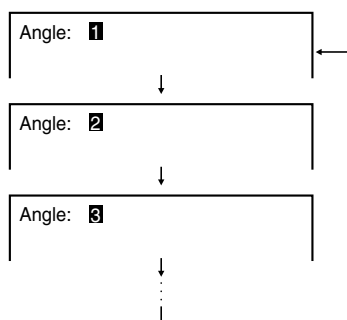

▼ : Cycles backwards

You can also change the camera angle directly by pressing the number buttons corresponding to the angle number.

### Notes

- You can change the camera angle during still playback. The camera angle changes to the new setting when you resume normal playback.
- If you pause a picture immediately after changing the camera angle, the resumed playback picture may not use the new camera angle.

# Turning on/off Subtitles

## Selecting the Subtitle Language

You can display subtitles on the TV screen and select a subtitle language from those included on the DVD video.

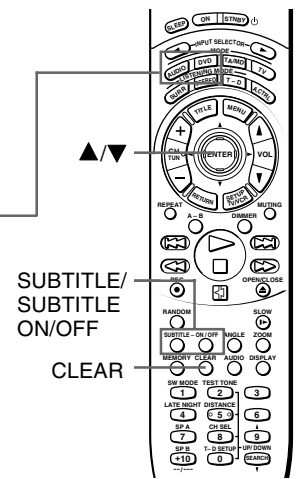

DVD

### Turning Subtitles on/off

Remote controller only

SUBTITLE - ON / OFF



#### Press SUBTITLE - ON/OFF during playback.

Each press of the button turns subtitles on or off. (The current subtitle setting is displayed for about 3 seconds.)

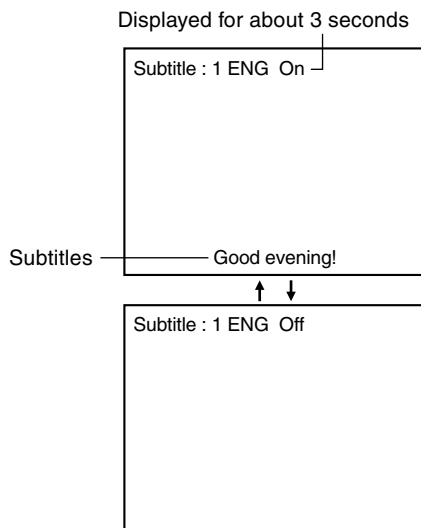

#### Notes

- Some DVD videos are set to display subtitles automatically, and you cannot turn them off even if you set the subtitle function to "Off."
- During some scenes, the subtitles may not appear immediately after you select "On."
- Some DVD videos will allow you to make subtitle selections and turn subtitles on or off only by using the disc menu.

DVD

### Selecting a Subtitle Language

You can select a subtitle language from those included on the DVD video.

1 Remote controller only

SUBTITLE - ON / OFF



#### Press SUBTITLE during playback.

The current subtitle setting is displayed for about 3 seconds.

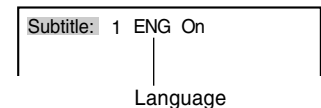

The abbreviation of the language appears instead of the language name. See the list of languages and their abbreviations on page 58.

2 SUBTITLE - ON / OFF



#### Press SUBTITLE or ▲ while the subtitle setting is displayed on the TV screen.

Each time you press SUBTITLE or ▲, the subtitle language changes to the next language included on the DVD video.

e.g.

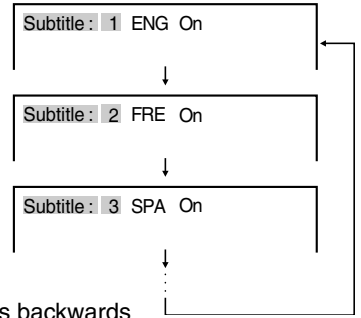

▼ : Cycles backwards

#### ■ To turn off the subtitle setting display

CLEAR



Press CLEAR.

#### Notes

- When you turn on the DVD Receiver or replace a disc, the DVD Receiver returns to the automatic setting in the setting menu (see pages 50 and 52).
- When you select a subtitle language which is not included on the disc, the DVD Receiver plays the default language programmed on the disc.
- During some scenes, the subtitles may not appear immediately after you change the subtitle language by pressing ▲/▼.

# Selecting Audio Language/Sound Included on the Disc

You can select a preferred audio language and sound system.

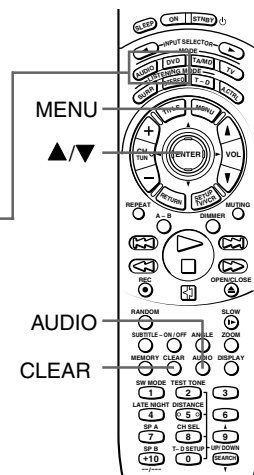
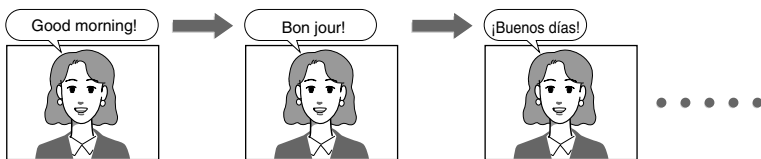

## DVD Selecting a Playback Audio Setting

You can select a set of preferred audio language and sound system from those included on the DVD video. This function enables you to temporarily change the audio language which has been selected as the automatic setting in the setting menu (see pages 50 and 52), and select the sound system if the DVD video is recorded in more than one sound format.

**1** Remote controller only  
**AUDIO**

**Press AUDIO during playback.**  
The current audio setting is displayed for about 3 seconds.

See next page.

The abbreviation of the language appears. Refer to the list of languages on page 58.

**2** Remote controller only  
**AUDIO**

**Press AUDIO or ▲ while the audio setting is displayed on the TV screen.**  
Each time you press AUDIO or ▲, the set of language and audio recording system changes.

e.g.

▼ : Cycles backwards

**Note**  
Dolby Digital 5.1 Channel sound may be displayed as "6CH."

## About recording systems

This DVD Receiver uses the Dolby Digital (5.1CH), DTS, MPEG2, and PCM (2 channel digital stereo) systems and cannot play DVD videos recorded in any other sound system.

### Notes

- Some discs only allow you to change audio selections by using the disc menu. If this is the case, press MENU and choose the appropriate language from the selections in the disc menu.
- Some discs may have only one set of audio language and sound recording system and you cannot make this selection.
- When you turn on the DVD Receiver or replace a disc, the DVD Receiver returns to the automatic setting in the setting menu (see page 52).

## VCD Selecting Sound Channels on VIDEO CDs

A VIDEO CD may have left and right sound channels which contain sounds or languages on each channel. You can switch these two channels to hear a preferred sound or language.

Remote controller only  
**AUDIO**

**During playback, press AUDIO (repeatedly) to select the sound channel.**

## To turn off the audio setting display



# Changing the Sound Signal Conversion Method

The reproduced disc sound will be output in the most suitable format automatically through the connected speakers and output connector/jacks on the DVD Receiver when "Audio Out Select" in the setting menu is set to "Bitstream" (see page 54).

However, you may need to convert the sound format in different ways depending on your purpose and preference.

For example, when you wish to:

- Listen to the high-frequency (kHz)/high-quantization (bit) format source in its original sound quality (see below), or
- Record the DVD video sound reproduced in the DOLBY DIGITAL format using recording equipment such as an MD recorder connected to the DIGITAL OUTPUT (OPT) connector on the DVD Receiver (see next page).

This function enables you to temporarily change the sound signal conversion method which has been selected automatically according to the automatic setting in the setting menu (see pages 50 and 54).

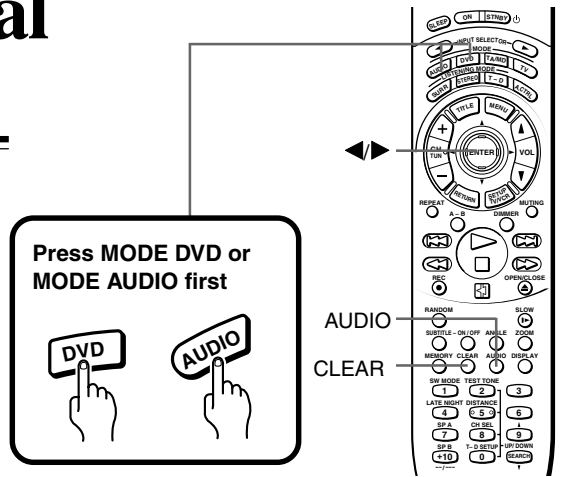

DVD VCD CD

## Changing the Sound Signal Conversion Method Temporarily

**1**  
Remote controller only  
**AUDIO**

**Press AUDIO during playback.**

The current audio setting is displayed for about 3 seconds.

Audio: 1 ENG PCM 2CH  
Audio OUT Select: Bitstream

See previous page.

The current sound signal conversion method

**2**

**Press ◀▶ while the audio setting is displayed on the TV screen.**

Audio: 1 ENG PCM 2CH  
Audio OUT Select: 96k Sound

Each time you press ◀▶, the setting changes as follows:

Bitstream ↔ 96k Sound ↔ PCM

For details about "Bitstream," "96k Sound," and "PCM," see the explanation on page 54 and the table on the opposite page.

### ■ To turn off the audio setting display

**CLEAR**  
Press CLEAR.

#### Notes

- The "Audio Out Select" setting in the setting menu (see page 54) is for automatic selection of the sound conversion method when the disc is inserted. Therefore, the selection in this section will not change the setting of "Audio Out Select" in the setting menu.
- When you turn on the DVD Receiver or replace a disc, the DVD Receiver returns to the automatic setting in the setting menu. (See page 54.)

DVD

## To Listen to a High-Frequency/High-Quantization Format Source in its Original Sound Quality – 96k Sound

The high frequency/high quantization sound signals below are converted into 48 kHz/16 bit sound signals and sent to the speakers when the "Audio Out Select" (sound signal conversion method) is set to the standard setting, "Bitstream."

### High frequency/high quantization signals

- 48 kHz/24 bit
- 96 kHz/16 bit
- 96 kHz/20 bit
- 96 kHz/24 bit

To listen to the high-frequency (kHz)/high-quantization (bit) format sounds in their original sound quality, follow the steps below.

<b>1</b>	<p><b>Change the sound signal conversion method to "96k Sound" following the steps on the left.</b></p> <p>See <b>a</b> in the table titled "Sound from the speakers" on the opposite page.</p> <p>The DVD videos recorded in 48 kHz/24 bit, 96 kHz/16 bit, 96 kHz/20 bit, and 96 kHz/24 bit are reproduced through the speakers at the same kHz and bit rate respectively.</p>
<b>2</b>	<p><b>If a subwoofer is connected, set the subwoofer mode to "SW Off."</b></p> <p>See "Setting the Subwoofer Mode" on page 17.</p>
<b>3</b>	<p><b>Change the sound to stereo.</b></p> <p>See "Changing the Sound to Stereo" on page 36.</p>

DVD

## Changing the DOLBY DIGITAL Surround Sound Format to the Digitally Recordable Frequency (kHz)/Quantization (bit)

Change the sound signal conversion method to “PCM” following the steps in “Changing the Sound Signal Conversion Method Temporarily” on the opposite page.

Referring to **Ⓒ** in the table below, the DOLBY DIGITAL Surround format will be converted into the 48 kHz/16 bit format which is recordable.

DVD

## Reproducing MPEG2 Sounds from DVD Videos

Referring to **Ⓒ** in the table below, MPEG2 sound is not reproduced from the speakers when the sound signal conversion method is the factory setting, “Bitstream.”

To reproduce MPEG2 sound from DVD Videos, change the sound signal conversion method to “96k Sound” or “PCM” following the steps in “Changing the Sound Signal Conversion Method Temporarily” on the opposite page.

DVD

## Changing the MPEG2 Sound Format of DVD Videos to Analog Signals for Recording

Digital recording of MPEG2 sounds is impossible regardless of the sound signal conversion methods. However, analog recording of MPEG2 is possible if you change the sound format to analog signals.

To record MPEG2 sounds from the analog output jacks, change the sound signal conversion method to “96k Sound” or “PCM” following the steps in “Changing the Sound Signal Conversion Method Temporarily” on the opposite page.

Referring to **Ⓘ** in the table below, the MPEG2 format will be converted into the recordable analog signals using the 48 kHz/16 bit format, whereas the MPEG2 sounds are not output to the analog output jacks when the sound signal conversion method is “Bitstream” (**Ⓒ** in the table below).

### Output sound conversion tables

#### Symbols in the tables

- The symbols **Ⓐ**, **Ⓒ**, **Ⓓ**, **Ⓗ**, and **Ⓙ** are referred to on the previous page and this page.
- The symbols **Ⓑ**, **Ⓔ**, **Ⓖ**, **Ⓔ**, and **Ⓕ** are referred to on page 60 in “Recording Using the Connected Equipment.”

#### Sound from the speakers

Discs	Sound systems* <sup>1</sup>	Conversion methods* <sup>2</sup>		
		Bitstream	96k Sound	PCM
DVD videos	DOLBY DIGITAL			
	Linear PCM	48 kHz/16 bit	Same kHz/bit as the source	
		48 kHz/20 bit	48 kHz/16 bit	Same kHz/bit as the source
		48 kHz/24 bit		
		96 kHz/16 bit		
		96 kHz/20 bit		
	96 kHz/24 bit	DTS	No sound	
MPEG2				48 kHz/16 bit
VIDEO CDs	MPEG1	44.1 kHz/16 bit		
Audio CDs	Linear PCM 44.1kHz/16 bit	Same kHz/bit as the source		
	DTS	DTS		

\*<sup>1</sup> Some discs have more than one sound system that can be selected (see page 45).

\*<sup>2</sup> You can change the conversion method temporarily as described on the previous page, or permanently using the setting menu (see pages 50 and 54).

#### Sound signals from the digital output and kHz/bit used to convert digital signals to analog signals

Discs	Sound systems* <sup>1</sup>	Digital output signals from the DIGITAL OUTPUT (OPT) connector			kHz/bit when converting Digital Signals to Analog Signals for Analog jacks				
		Conversion methods* <sup>2</sup>			Conversion methods* <sup>2</sup>				
		Bitstream	96k Sound	PCM	Bitstream	96k Sound	PCM		
DVD videos	DOLBY DIGITAL				<b>Ⓑ</b> Bitstream	<b>Ⓒ</b> 48 kHz/16 bit	48 kHz/20 bit	48 kHz/20 bit	48 kHz/20 bit
	Linear PCM	Same kHz/bit as the source			48 kHz/16 bit	48 kHz/16 bit	48 kHz/16 bit	48 kHz/16 bit	
		48 kHz/16 bit	48 kHz/20 bit	No signal is output.	48 kHz/16 bit	48 kHz/20 bit	48 kHz/20 bit	48 kHz/20 bit	
			48 kHz/24 bit			48 kHz/24 bit	48 kHz/20 bit		
			96 kHz/16 bit			96 kHz/16 bit	48 kHz/16 bit		
			96 kHz/20 bit			96 kHz/20 bit	48 kHz/16 bit		
	96 kHz/24 bit	96 kHz/24 bit	48 kHz/20 bit						
DTS		Bitstream		<b>Ⓙ</b> No signal	<b>Ⓔ</b> No signal				
MPEG2		Bitstream (7.1ch)	Bitstream (2ch)	48 kHz/16 bit	<b>Ⓗ</b> No signal	<b>Ⓘ</b> 48 kHz/16 bit			
VIDEO CDs	MPEG1	44.1 kHz/16 bit			44.1 kHz/16 bit				
Audio CDs	Linear PCM 44.1 kHz/16 bit	Same kHz/bit as the source			44.1 kHz/16 bit				
	DTS	Bitstream			<b>Ⓔ</b> No Signal				

# Using Information on the On-Screen Display and the DVD Receiver's Display

You can view information about a disc and its operational status on the TV screen and the DVD Receiver's display.

## Note

Some DVD videos may not display the chapter number or elapsed time.

DVD VCD CD

## Checking the Total Number of Titles/Tracks, Current Title/Chapter/Track, Remaining and Elapsed Time, etc.

### When the disc is inserted in the DVD Receiver

The following information appears in the DVD Receiver's display for about five seconds.

#### DVD video\*

e.g.

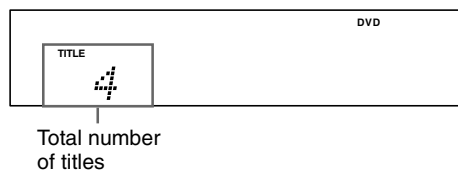

\* Playback may automatically start depending on the DVD video. In this case, the information on the left doesn't appear.

#### VIDEO CD/Audio CD

e.g.

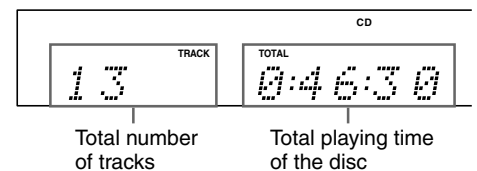

Remote controller

DISPLAY



Unit DISPLAY



### Press DISPLAY while the disc is stopped.

Each time you press DISPLAY, the on-screen display on the TV screen changes as follows.

#### DVD video

e.g.

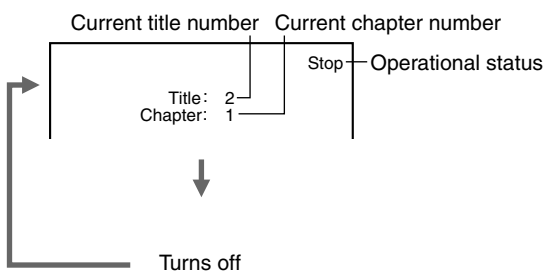

#### VIDEO CD/Audio CD

e.g.

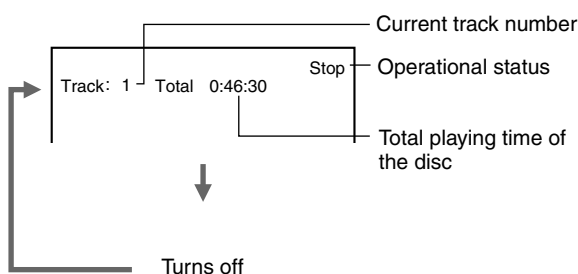

Each time you press DISPLAY, the DVD Receiver's display changes as follows.

#### DVD video

e.g.

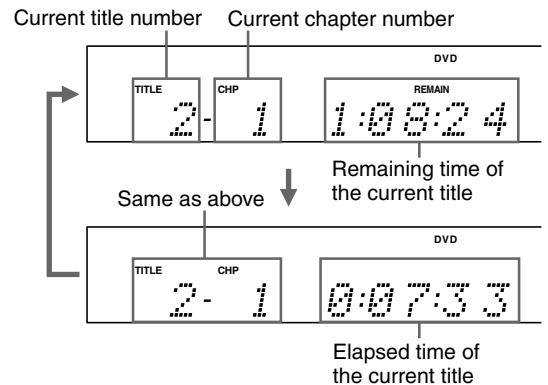

#### VIDEO CD/Audio CD

e.g. (When an audio CD is in the DVD Receiver.)

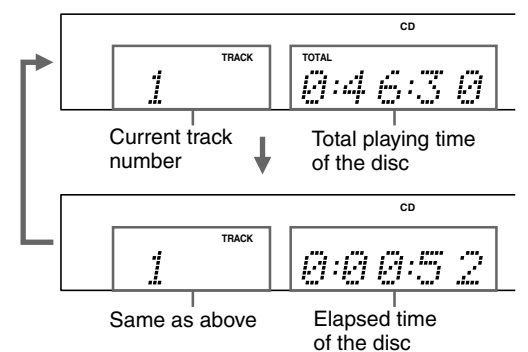



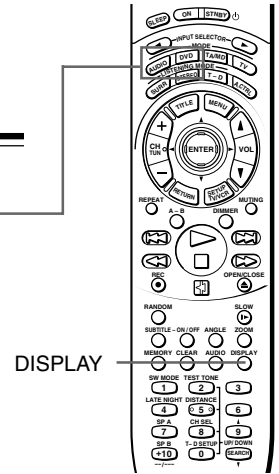
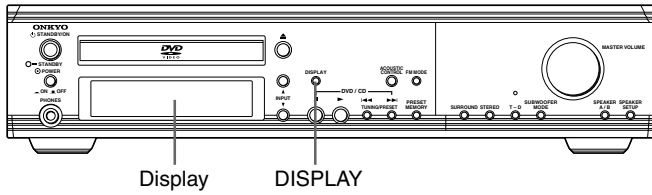

Remote controller

DISPLAY



Unit  
DISPLAY



### Press DISPLAY during playback.

Each time you press DISPLAY, the on-screen display on the TV screen changes as follows.

#### DVD video

e.g.

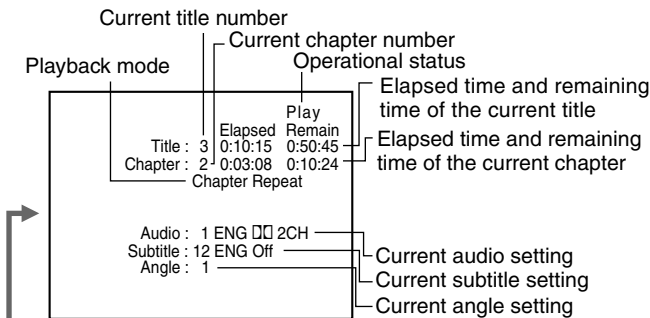

The abbreviation of the language (e.g. ENG) appears instead of the language name. See the list of languages and their abbreviations on page 58.



Data transfer rate (Mbit/s):  
The amount of picture, sound and subtitle data in the DVD video transferred per second.  
The larger the value is, the faster data is processed, but this does not necessarily ensure better picture quality.

Turns off.

#### VIDEO CD/Audio CD

e.g.

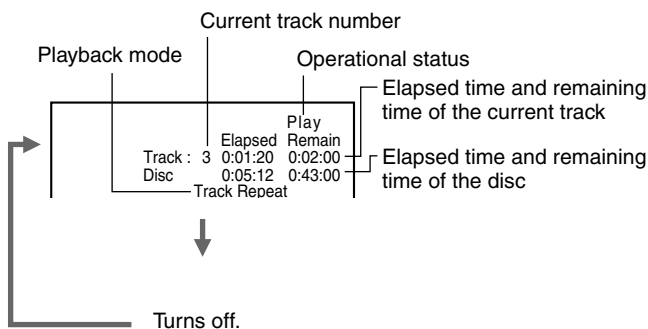

Turns off.

Each time you press DISPLAY, the DVD Receiver's display changes as follows.

#### DVD video

e.g.

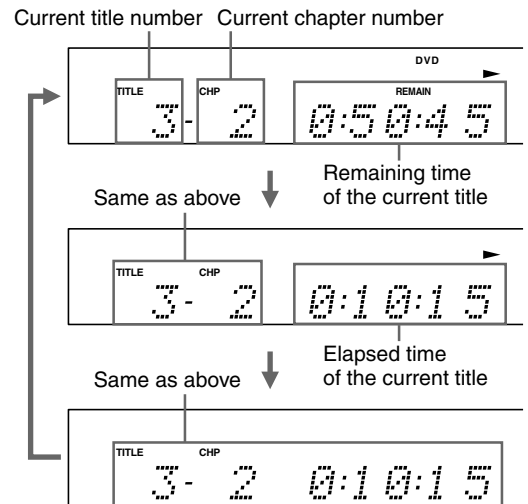

#### VIDEO CD/Audio CD

e.g. (When an audio CD is in the DVD Receiver.)

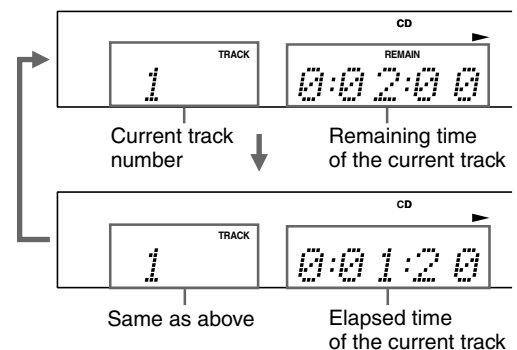

# Customizing the Function Settings

When you insert a DVD Video, VIDEO CD, or audio CD, the various functions of the DVD Receiver will be set (reset) according to the setting menu. You can customize this setting menu according to your preference.



## Before operating

SETUP can function even during normal playback. However, if an operation is inaccessible, a message will appear. In this case, try again after playback is stopped.

DVD VCD CD

## Setting Steps

**1** Remote controller only



**Press SETUP.**  
The following setting menu appears.

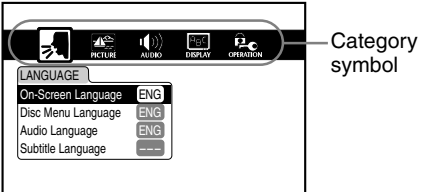





Category symbol

**2**



**Press ◀▶ to select a category symbol for the setting you want to change.**

-  Setting languages
-  Setting playback picture conditions
-  Setting sound output
-  Setting displays
-  Setting operational options

**3**



**Press ▲/▼ to select the item you want to change, then press ENTER.**

e.g. When you select "PICTURE" as the category in step 2, then select "TV Shape" as the item in this step.

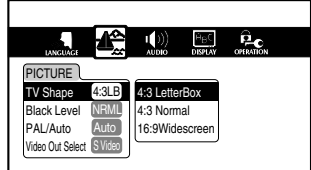

**4**



**Press ▲/▼ to change the setting, then press ENTER.**

e.g. When you change the "TV Shape" setting to "16:9Widescreen."

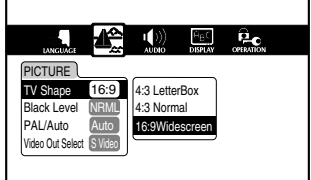

**5**

Further steps may be needed depending on the item or setting. Follow the steps described in the explanation of each item starting from page 52.

**6**

- To change the setting of other items in the same category, repeat steps 3 to 5.
- To change the setting of an item in a different category, repeat steps 2 to 5.

**7**



To close the setting menu, press SETUP.

■ To return to the previously displayed menu





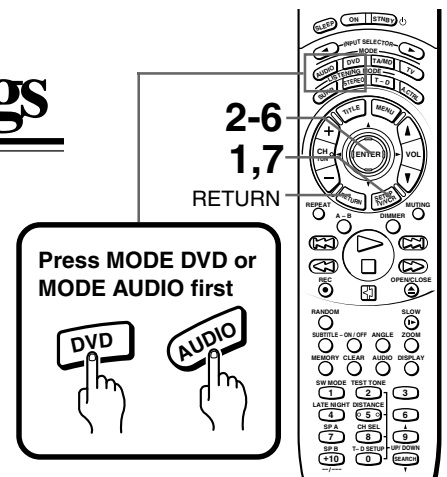



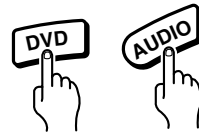





























Press RETURN.



Press MODE DVD or MODE AUDIO first



## Reference Table of the Setting Menu

Category Symbol	Menu item	Related to	Details	Page
	On-Screen Language	  	To select a preferred language for on-screen displays	52
	Disc Menu Language		To select a preferred language for disc menus	52
	Audio Language		To select a preferred language for the sound track	52
	Subtitle Language		To select a preferred language for subtitles	52
	TV Shape		To select a picture size according to the aspect ratio of your TV	53
	Black Level	 	To select the black level of playback picture	53
	PAL/Auto	 	To select the video system of a disc	53
	Video Out Select	 	To select the video output corresponding to your TV system	53
	Audio Out Select	  	To select a sound signal conversion method according to your purpose and preference	54
	Dynamic Range Control		To turn on or off a function that makes faint sounds easier to hear even if you lower the volume during late night playback	54
	Karaoke Vocal		To turn on or off the vocal output during KARAOKE disc playback	54
	Extended Audio Feature		To turn on or off narration for visually impaired persons	54
	On-Screen Displays	  	To turn on or off the operational status display (On-screen display) on the TV screen	55
	OSD Background Color	  	To select the background color for on-screen displays	55
	Extended Subtitle Features		To turn on or off special subtitles for hearing impaired persons	55
	Screen Saver		To turn on or off the screen saver	55
	Pause/Still		To select the resolution of still pictures (Field/Frame)	56
	Parental Lock		To turn on or off the parental lock function	56
	Title Stop		To turn on or off a feature that automatically stops playback after a title has finished	57
	PBC		To use the menu screen when playing a PBC-controllable VIDEO CD	57

# Customizing the Function Settings

## Explanation of Each Item in the Language Category

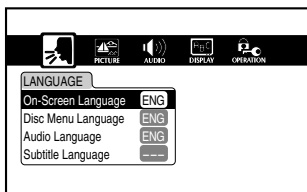

### Note

To know the factory setting for each item, see the on-screen illustration on the left.

### On-Screen Language



Select an on-screen language from the following:

- English
- French
- German
- Spanish
- Italian

### Disc Menu Language



Select a disc menu language from the following:

- English
- French
- German
- Spanish
- Italian
- Others → Continue to “Choosing Another Language” in the right column of this page.

### Note

Some DVD videos may not include your pre-selected language. In this case, the DVD Receiver automatically displays disc menus consistent with the disc's initial language setting.

### Audio Language



Select an audio language from the following:

- English
- French
- German
- Spanish
- Italian
- Others → Continue to “Choosing Another Language” in the right column of this page.

### Note

Some DVD videos may be played in a different language than you selected because an initial language may be programmed on the disc.

### Subtitle Language



Select a subtitle language or no subtitle setting from the following:

- English
- French
- German
- No Subtitles: Select this when you disable subtitles.
- Others → Continue to “Choosing Another Language” below.

### Notes

- Some DVD videos may be set to display subtitles in a different language than you selected.
- Some DVD videos allow you to change subtitle selections only by using the disc menu. If this is the case, press MENU and choose the appropriate subtitle language from the selection on the disc menu.

### ■ Choosing Another Language

After pressing ENTER in step 4 of “Setting Steps” on page 50:

- 1 Obtain the abbreviation of the preferred language from the Table of Languages on page 58.
- 2 Select the first character of the abbreviation by pressing ▲/▼. e.g. When you select “Others” in “Disc Menu Language.”
- 3 Press ◀/▶ to move the cursor to the next column, then select the second character of the abbreviation by pressing ▲/▼.
- 4 Press ENTER.

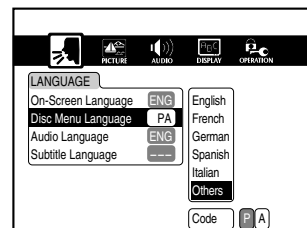

## Explanation of Each Item in the Picture Category

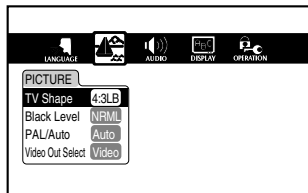

### Note

To know the factory setting for each item, see the on-screen illustration on the left.

### TV Shape



- **4:3 Letterbox:** Select when a 4:3 TV is connected.

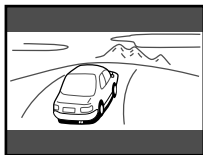

Displays widescreen images with masking bars above and below the picture.

- **4:3 Normal:** Select when a 4:3 TV is connected.



Displays pictures cropped to fill your TV screen. Either or both sides of the picture are cut off.

- **16:9 Widescreen:** Select when a 16:9 wide TV is connected.

### Notes

- The displayable picture size is preset on each DVD video. Therefore, the playback picture of some DVD videos may not conform to the picture size you select.
- When you play a DVD video recorded in the 4:3 picture size only, the playback picture always appears in the 4:3 picture size regardless of the TV shape setting.
- If you select "16:9Widescreen" and you own a 4:3 TV set, the DVD playback picture will be horizontally distorted during playback. Images will appear to be horizontally compressed. Make sure the TV Shape conforms to the actual TV in use.

### Black Level



Set according to your preference and the TV's capability.

- **Normal:** Standard black level
- **Light:** Brighter than in "Normal"

### PAL/Auto



- **PAL:** Select to play PAL discs. Connect a PAL TV to view pictures.
- **Auto:** The DVD Receiver automatically detects PAL and NTSC video systems of discs. Connecting a multisystem TV (PAL/NTSC compatible) is needed to view pictures.

### Note

A playback picture may be distorted temporarily when the detected signal changes between PAL and NTSC on the disc.

### Video Out Select



This setting is related to the TV or monitor connected to the DVD Receiver (see page 10).

- **Video:** Select when connected to a normal TV.
- **S Video:** Select when connected to a TV compatible with S video signals.
- **RGB:** Select when connected to an RGB monitor.

# Customizing the Function Settings

## Explanation of Each Item in the Audio Category

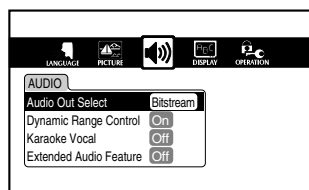

### Note

To know the factory setting for each item, see the on-screen illustration on the left.

### Audio Out Select



The output sound format can be changed according to your purpose and preference by changing the sound signal conversion method.

The sound signal conversion method is selected from among the three listed below. (Note that the three items are sound signal conversion methods, not the sound signal format the sound signals are converted into.)

When "Audio Out Select" is set to "Bitstream," the sound is output in the most suitable format automatically through the speakers and output connector/jacks. Therefore, although you can change the sound signal conversion method using the menu, leaving the "Audio Out Select" setting to "Bitstream" and changing the method according to your purpose temporarily as described on page 46 is recommended.

For details (tips on using of this function, sampling frequency and quantization bit conversion table, etc.), see pages 46 and 47.

#### Bitstream

Normally use this setting.

#### 96k Sound

Select when you wish to listen to sources recorded in the following frequency/quantization bit in their original sound quality:

- 96 kHz/24 bit
- 96 kHz/20 bit
- 96 kHz/16 bit
- 48 kHz/24 bit

For instructions on how to reproduce the above original sounds, see page 46.

#### PCM

Select to convert DOLBY DIGITAL sound into the sound format recordable by equipment such as an MD recorder connected to the DIGITAL OUTPUT (OPT) connector on the DVD Receiver (see pages 11 and 47).

### Dynamic Range Control



- **Off:** Full dynamic range is maintained.
- **On:** Dynamic range is reduced.

#### Notes

- This function works only with playback of Dolby Digital recorded discs.
- The level of Dynamic Range Reduction may differ depending on the DVD video.

### Karaoke Vocal



The vocal output feature is used during playback of Dolby Digital (multichannel) recorded DVD KARAOKE discs. This feature allows you to turn off vocal audio tracks, or restore them for background accompaniment.

- **Off:** The primary vocal is not output.
- **On:** The primary vocal is output if it is recorded on the disc.

### Extended Audio Feature



Some DVD videos contain a narration track for visually impaired persons. The DVD Receiver automatically plays the narration track by setting this item to "On."

- **Off:** The narration track is not played.
- **On:** The narration track is played automatically.

## Explanation of Each Item in the Display Category

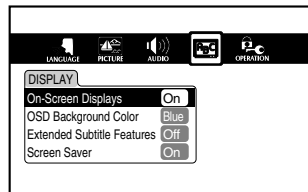
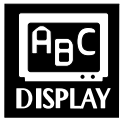

### Note

To know the factory setting for each item, see the on-screen illustration on the left.

### On-Screen Displays DVD VCD CD

- **Off:** Operational modes are not displayed on the TV screen.
- **On:** Operational modes are displayed on the TV screen (e.g. "PLAY", .

### OSD Background Color DVD VCD CD

- **Blue:** Blue background.
- **Gray:** Gray background.

### Extended Subtitle Features DVD

Some DVD videos contain special subtitles, an enhancement of closed captions for hearing impaired persons. The DVD Receiver automatically displays these special subtitles by setting this item to "On."

- **Off:** The extended subtitles are not displayed.
- **On:** The extended subtitles are displayed automatically.

### Screen Saver DVD

- **Off:** The screen saver is disabled.
- **On:** The screen saver is enabled.

# Customizing the Function Settings

## Explanation of Each Item in the Operation Category

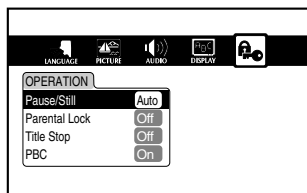

### Note

To know the factory setting for each item, see the on-screen illustration on the left.

### Pause/Still



- **Auto:** Select for normal use. The image can be paused without shaking.
- **Frame:** The resolution of the still pictures is improved so that you can make a motionless picture clearer when you pause it.

### Parental Lock



DVD videos equipped with the parental lock function are rated according to their content. The content allowed by a parental lock level and the way a DVD video can be controlled may vary from disc to disc. For example, some discs allow you to edit out violent scenes unsuitable for children and replace them with more suitable scenes, or lock out playback of the disc altogether.

- **Off:** Select to disable the parental lock feature. Then, carry out "Further Steps" in the right column of this page.
- **On:** Select to activate the parental lock feature or change the settings. Then, carry out "Further Steps" in the right column of this page.

### Note

DVD videos may or may not respond to the parental lock settings. This is not a defect in the DVD Receiver. Make sure this function works with your DVD videos.

### Further Steps

After pressing ENTER in step 4 of "Setting Steps" on page 50,

- 1 Press the number buttons to create a personal 4-digit security code, then press ENTER.

(To reenter the security code, before pressing ENTER, press CLEAR then enter the security code.)

- **When you select "Parental Lock On"**  
Continue to the next step.
- **When you select "Parental Lock Off"**  
The parental lock is disabled.

- 2 Press ◀▶ to select the country whose standards were used to rate the DVD video.

- 3 Press ▲▼ to select the parental lock level, then press ENTER.

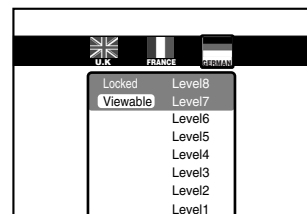
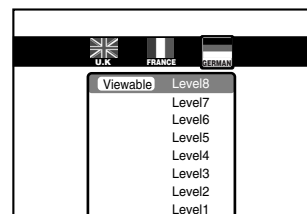
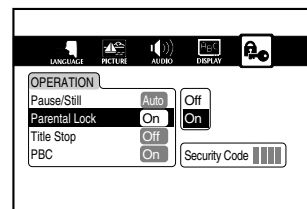
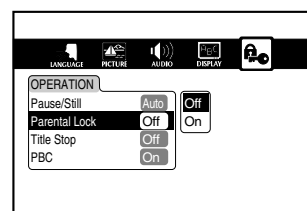

The parental lock is activated.

You cannot play DVD videos rated higher than the level you select unless you cancel the parental lock function. For example, when you select level 7, discs rated higher than level 7 are locked out and cannot be played.

### ■ To change the parental lock level

Follow the above procedure.



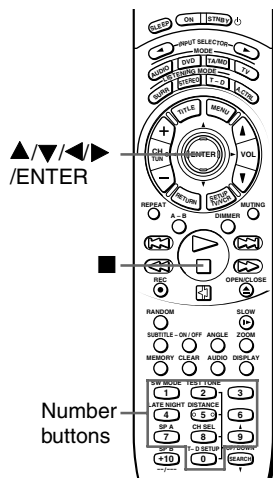

## ■ To change your 4-digit security code

After selecting “On” or “Off” and pressing ENTER in step 4 of “Setting Steps” on page 50:

- 1 Press ■ four times on the remote controller, then press ENTER.



The 4-digit security code is cleared.

- 2 Press the number buttons to create a new 4-digit security code.
- 3 Press ENTER.

## Title Stop



- **Off:** The DVD Receiver continues playback after playback of a title is complete.
- **On:** The DVD Receiver stops playback after playback of a title is complete.

## PBC



PBC is the abbreviation for Playback Control (see “About VIDEO CDs” on page 9.)

- **Off:** Select to play a PBC-featured VIDEO CD without using the menu screen.
- **On:** Select to view the menu screen when playing a PBC-featured VIDEO CD.

# Table of Languages

## Table of Languages and Their Abbreviations

Abbreviation of the Language	Language	Abbreviation of the Language	Language	Abbreviation of the Language	Language	Abbreviation of the Language	Language
—	No alternate language	EO	Esperanto	LN	Lingala	SL	Slovenian
CHI (ZH)	Chinese	ET	Estonian	LO	Laotian	SM	Samoan
DUT (NL)	Dutch	EU	Basque	LT	Lithuanian	SN	Shona
ENG (EN)	English	FA	Persian	LV	Latvian, Lettish	SO	Somali
FRE (FR)	French	FI	Finnish	MG	Malagasy	SQ	Albanian
GER (DE)	German	FJ	Fiji	MI	Maori	SR	Serbian
ITA (IT)	Italian	FO	Faroese	MK	Macedonian	SS	Siswati
JPN (JA)	Japanese	FY	Frisian	ML	Malayalam	ST	Sesotho
KOR (KO)	Korean	GA	Irish	MN	Mongolian	SU	Sundanese
MAY (MS)	Malay	GD	Scottish, Gaelic	MO	Moldavian	SV	Swedish
SPA (ES)	Spanish	GL	Galician	MR	Marathi	SW	Swahili
AA	Afar	GN	Guarani	MT	Maltese	TA	Tamil
AB	Abkhazian	GU	Gujarati	MY	Burmese	TE	Telugu
AF	Afrikaans	HA	Hausa	NA	Nauru	TG	Tajik
AM	Amharic	HI	Hindi	NE	Nepali	TH	Thai
AR	Arabic	HR	Croatian	NO	Norwegian	TI	Tigrinya
AS	Assamese	HU	Hungarian	OC	Occitan	TK	Turkmen
AY	Aymara	HY	Armenian	OM	(Afan) Oromo	TL	Tagalog
AZ	Azerbaijani	IA	Interlingua	OR	Oriya	TN	Setswana
BA	Bashkir	IE	Interlingue	PA	Panjabi	TO	Tongan
BE	Belorussian	IK	Inupiak	PL	Polish	TR	Turkish
BG	Bulgarian	IN	Indonesian	PS	Pashto, Pushto	TS	Tsonga
BH	Bihari	IS	Icelandic	PT	Portuguese	TT	Tatar
BI	Bislama	IW	Hebrew	QU	Quechua	TW	Twi
BN	Bengali, Bangla	JI	Yiddish	RM	Rhaeto-Romance	UK	Ukrainian
BO	Tibetan	JW	Javanese	RN	Kirundi	UR	Urdu
BR	Breton	KA	Georgian	RO	Rumanian	UZ	Uzbek
CA	Catalan	KK	Kazakh	RU	Russian	VI	Vietnamese
CO	Corsican	KL	Greenlandic	RW	Kinyarwanda	VO	Volapük
CS	Czech	KM	Cambodian	SA	Sanskrit	WO	Wolof
CY	Welsh	KN	Kannada	SD	Sindhi	XH	Xhosa
DA	Danish	KS	Kashmiri	SG	Sango	YO	Yoruba
DZ	Bhutani	KU	Kurdish	SH	Serbo-Croatian	ZU	Zulu
EL	Greek	KY	Kirghiz	SI	Singhalese		
		LA	Latin	SK	Slovak		

# Recording Using the Connected Equipment

You can record according to the following using the connected recording equipment:

- Sound/picture of discs played back by the DVD Receiver,
- Sound of FM/AM programs, and
- Sound/picture of the connected source.

**Note**

Many discs and sources are copy protected. Copy protected sources are impossible to record.

■ **Simplified diagram of the connected equipment (See also pages 10 and 11 for the actual connections.)**

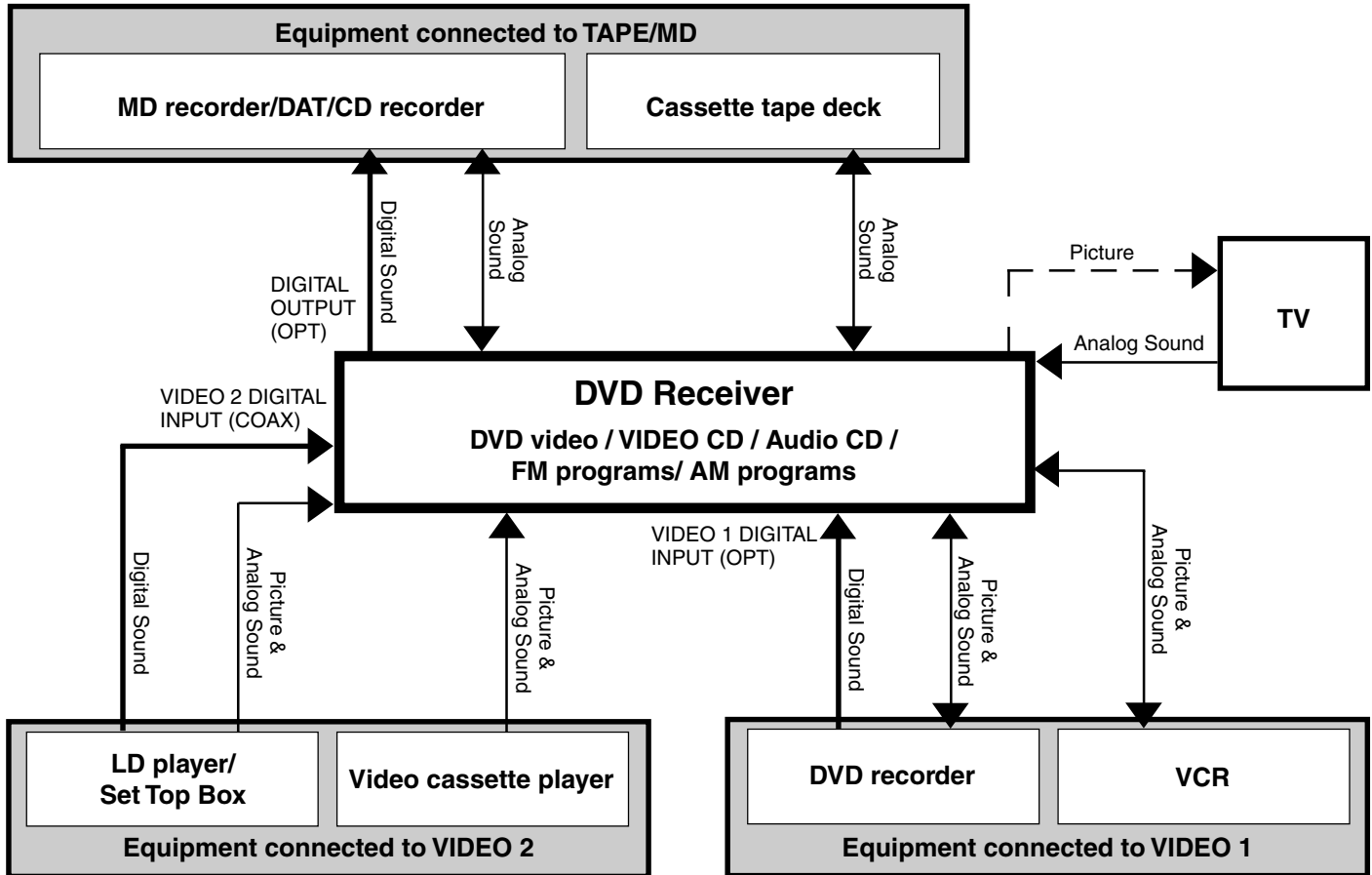

## Basic Recording Procedure

<b>1</b>	<b>Set the recording equipment (MD recorder, DAT, Cassette tape deck, VCR, DVD recorder, CD recorder, etc.) to recording pause.</b>
<b>2</b>	<b>Select the input source to be recorded, then set it to play pause.</b> <ul style="list-style-type: none"> <li>• To play and pause a DVD video, VIDEO CD, or audio CD, see page 21.</li> <li>• To select an FM/AM program, see page 26.</li> <li>• To select a connected source, see page 28.</li> </ul> Refer to the manuals of the connected source equipment for instructions on how to play and pause.
<b>3</b>	<b>Release the recording pause set in step 1 to start recording.</b>
<b>4</b>	<b>Start playback of the selected source in step 2.</b>

**Notes**

- If you select another input source during recording, the selected source will be recorded.
- Sound effects described on pages 32 to 38 do not affect the recorded sounds whereas the sound set in the AUDIO setting menu (see pages 50 and 54) will be recorded.

# Recording Using the Connected Equipment

## ■ Recording the Picture and Sound From Different Sources at the Same Time

The picture from the playing VIDEO 2 source is output through the VIDEO OUT jacks when you select any audio source (TAPE/MD, FM, or AM) or TV/LINE.

Play the VIDEO 2 source and select TAPE/MD, FM, AM, or TV/LINE, then you can record the picture from the VIDEO 2 source and the sound from the selected input source at the same time, using the recording equipment connected to the VIDEO 1 jacks.

## ■ Digital recording from the source connected to the digital input connectors to the digital recording equipment connected to the digital output connector

The digital input connectors are as follows:

- The VIDEO 1 DIGITAL INPUT (OPT) connector, and
- The VIDEO 2 DIGITAL INPUT (COAX) connector.

The digital output connector is the DIGITAL OUTPUT (OPT) connector.

Recording digital sound signals from sources connected to the digital input connectors using digital recording equipment connected to the digital output is possible unless:

- The recording is against SCMS (Serial Copy Management System) rules (for details of SCMS rules, refer to the manual of the digital recording equipment),
- The digital signals are in bitstream format (the recordable digital signal format is PCM — two channel digital stereo sound signals), or
- The sampling frequency is out of the recordable range of the recording equipment (for recordable sampling frequency, refer to the manual of the digital recording equipment). Note that the maximum signal frequency output from the DVD Receiver is 48 kHz.

## ■ Analog recording from a DVD Video played using the DVD Receiver

The digital sound signals are converted to analog signals and output to the analog output jacks unless the DVD video is recorded in the DTS Surround or MPEG2 system.



MPEG2 sounds can be recorded by changing the sound signal conversion method to "96k Sound" or "PCM." For details, see page 47.

Although the speakers can reproduce DTS Surround sounds, DTS signals are not output to the analog output jacks. See  in the table on page 47.

### Note

If the sound signal conversion method is set to "96k Sound," reproduced PCM signals may not be output from the digital output connector (DIGITAL OUTPUT (OPT)) depending on the frequency and quantization. See also the second note in "Digital recording from a DVD video played by the DVD Receiver" in the right column of this page.



## ■ Digital recording from a DVD video played by the DVD Receiver

The digital sound signals are output to the DIGITAL OUTPUT (OPT) connector in the most suitable format when the sound signal conversion method is set to "Bitstream" (see page 54). However, if the conversion method is set to "Bitstream" or "96k Sound" when DOLBY DIGITAL Surround sound is reproduced, the signals will be output in the bitstream format from the DIGITAL OUTPUT (OPT) connector as in  in the table on page 47. The bitstream signals are unrecordable. Therefore, to record the sounds recorded in the DOLBY DIGITAL Surround sound format, you need to change the conversion method to "PCM." Once the conversion method is changed to "PCM," the DOLBY DIGITAL sound signals are converted into the 2 channel 48 kHz/16 bit PCM format as in  in the same table mentioned above.

Digital recording of MPEG2 sounds is impossible regardless of the sound signal conversion methods. (Analog recording is possible. See on the left.)

DTS Surround sound is unrecordable from both the digital output connector and analog output jacks regardless of the sound signal conversion methods.

### Notes

- If the conversion method is set to "PCM," the DTS Surround sounds of a DVD video will not be reproduced from the speakers nor output to the DIGITAL OUTPUT (OPT) connector. See  in the tables on page 47.
- If the sound signal conversion method is set to "96k Sound," the DIGITAL OUTPUT (OPT) connector will not output any signals depending on the frequency and quantization as in  in the table on page 47.  
To digitally record high frequency PCM sound signals, the conversion method must be set to "Bitstream" or "PCM," so that the frequency/quantization are converted to the 48 kHz/16 bit format, which is recordable.

## ■ Analog and Digital recording from a VIDEO CD played using the DVD Receiver

VIDEO CDs are recorded in the MPEG1 format.

MPEG1 sounds are recordable regardless of the conversion method. MPEG1 sound signals are output to the DIGITAL OUTPUT (OPT) connector in the 44.1 kHz/16 bit format, and at the same time, converted to analog signals and output to the analog jacks.

## ■ Analog and Digital recording from an audio CD played using the DVD Receiver

PCM sound signals are output to the DIGITAL OUTPUT (OPT) connector, and converted to analog signals and output to the analog output jacks regardless of the conversion method.

DTS Surround sound is unrecordable. Because DTS Surround sound signals of an audio CD are output to the DIGITAL OUTPUT (OPT) connector in the bitstream format and no signal will be output to the analog output jacks regardless of the conversion method. For details, see the tables on page 47.

# Programming the Remote Controller to Your TV

You can program the supplied remote controller (RC-437M) to operate your TV.

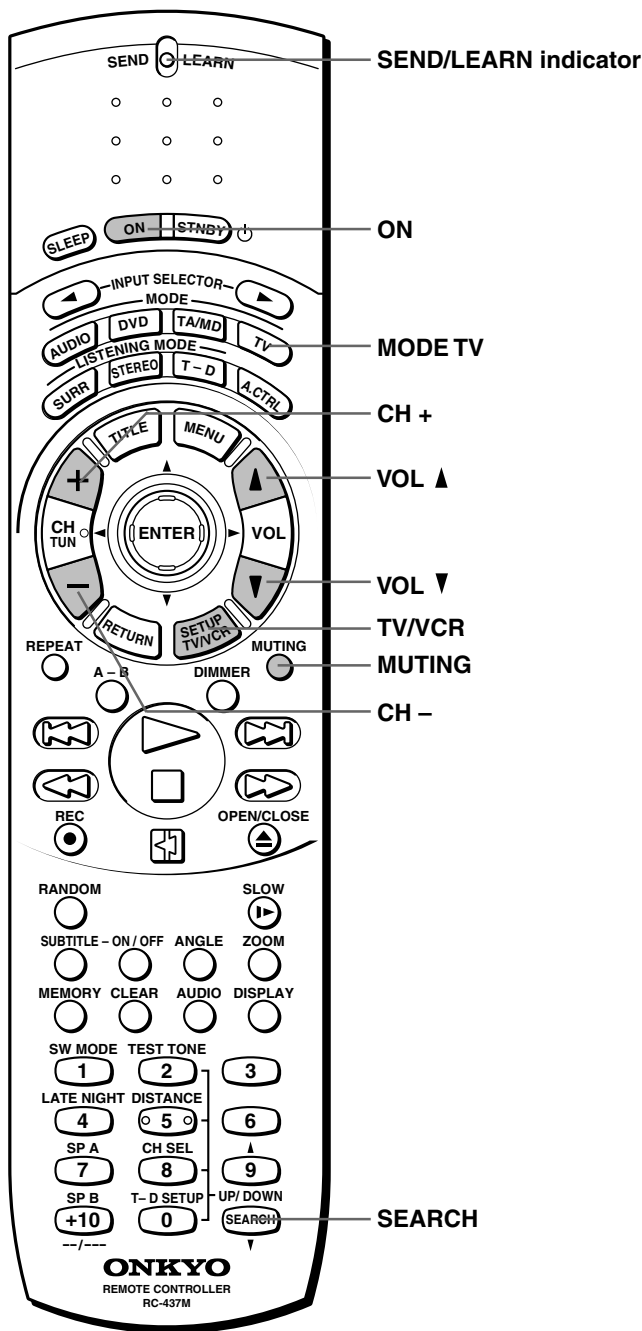

## Note

The programmed buttons of the DVD Receiver's remote controller may lose their data if the batteries become weak or dead, or due to other causes. In such a case, you need to repeat programming from the beginning using the TV's remote control. Therefore, keep the TV's remote control in a safe place even if it is not in use.

## Before programming the remote controller

- If the SEND/LEARN indicator flashes three times, the programming is unsuccessful. Repeat from step 2.
- Use new batteries for the remote controller and the TV's remote control. Using old batteries may result in a failure in programming or cause the programmed remote controller buttons to operate improperly.
- The remote controller and most other remote controls transmit infrared rays, however, if the other remote control uses another method, programming is impossible.
- Although seven buttons are prepared for operating the TV, the number of programmable buttons varies depending on the manufacturer and type of the other remote control.
- Switch off the main power of the DVD Receiver and TV to prevent the units from undesired operation during programming.
- The remote control buttons on some TVs may have more than one function; however, only one function can be programmed per button.
- Refer also to the TV's instruction manual for details on its remote control operation and other information.

## Programming the Remote Controller

Programming is carried out by copying the signal patterns of the TV's remote control buttons.

1

Place both the DVD Receiver's remote controller and the TV's remote control facing with each other on a flat level surface.

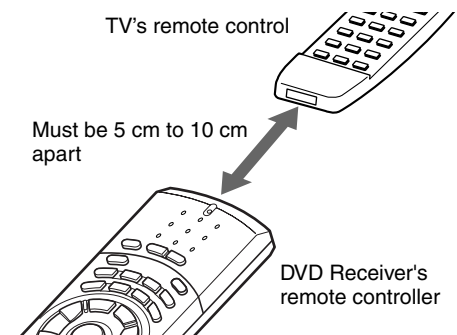

2



At the same time



Press and hold **MODE TV**, then press **SEARCH** once.

The SEND/LEARN indicator lights up and the remote controller enters the programming mode.

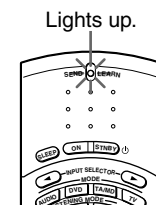

Proceed to the next step within 30 seconds.

(Continued on next page.)

# Programming the Remote Controller to Your TV

**3**

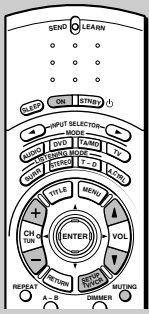

**Press one of the programmable buttons on the DVD Receiver's remote controller.**

The SEND/LEARN indicator goes off while the button is pressed, then lights up again.

Lights up again shortly after going off

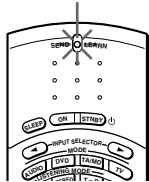

Proceed to the next step within 30 seconds.

**To select another programmable button**

Press one of the other programmable buttons within 30 seconds.

**4**

One of the TV's remote control buttons

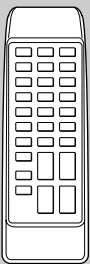

**Press and hold the desired TV's remote control button until the SEND/LEARN indicator flashes.**

If the function is successfully copied, the SEND/LEARN indicator flashes twice.

- Flashes twice when the programming is successful.
- Flashes three times if the programming has failed.
- Flashes six times if the programming is failed because the data capacity of the programmable button has been exceeded. TV buttons whose data size overwhelms the capacity of the programmable buttons are unable to be used for programming.

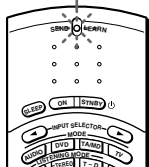

■ **Resuming the factory settings for all the programmable buttons**

**1 Press and hold MODE TV, then press SEARCH twice.**

The SEND/LEARN indicator flashes twice, then lights steadily.

Proceed to the next step within 30 seconds.

**2 Press MODE TV.**

- When the factory settings resume, the SEND/LEARN indicator flashes twice.
- If failed, the SEND/LEARN indicator flashes three times. In this case, no change has been made to the programmable buttons.

**If the programmed buttons do not operate properly**

- If the SEND/LEARN indicator doesn't light up when you press one of the programmed buttons, reprogram the button.
- If the remote controller operates only at a short distance or there is a slow response from the TV, check the batteries. If the batteries are not weak, the pressed button is not properly programmed. Reprogram the button.
- If the remote controller remains without batteries for 10 minutes or more, the programmed data will be erased. In such a case, install new batteries, then reprogram the buttons.

## Using the Programmed Buttons

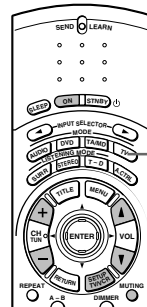

**Press MODE TV first, then press the programmed TV operation buttons.**

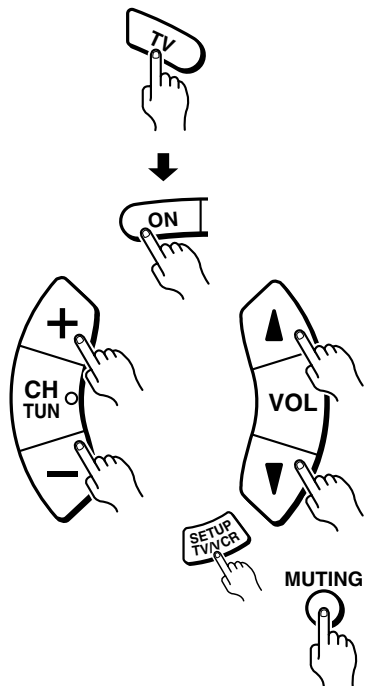

■ **Programming another function to the programmed button**

Carry out the steps from 1 to 4.

The previous function will be erased when the programming is successful.

■ **Resuming the factory setting for a particular programmable button**

After step 2, press the programmable button you wish to resume to the factory setting twice.

- When the factory setting resumes, the SEND/LEARN indicator flashes twice.
- If failed, the SEND/LEARN indicator flashes three times. In this case, no change has been made to the programmable button.

# Troubleshooting

Check the following guide for the possible cause of a problem before contacting service. Refer also to the respective instruction manuals of the connected components and TV.

	Symptoms	Causes	Remedies	Pages
Amplifier	The DVD Receiver doesn't switch on.	<ul style="list-style-type: none"> <li>The power cord (mains lead) is disconnected.</li> <li>The main power is set to OFF.</li> <li>There is external noise interfering with the computer circuits of the DVD Receiver.</li> <li>The AC fuse is blown.</li> </ul>	<ul style="list-style-type: none"> <li>Check the connection of the power cord (mains lead).</li> <li>Turn on the main power.</li> <li>Switch off the main power, then switch it on again. If not recovered, disconnect the power cord (mains lead), then connect it again.</li> <li>Contact your nearest Onkyo service center.</li> </ul>	16 16 16 –
	No sound is reproduced.	<ul style="list-style-type: none"> <li>The muting function is activated.</li> <li>The DVD Receiver is not properly connected.</li> <li>The amplifier protection circuitry has activated. (The STANDBY indicator flashes.)</li> <li>Headphones are connected.</li> </ul>	<ul style="list-style-type: none"> <li>Deactivate the muting function.</li> <li>Check the connections to the DVD Receiver.</li> <li>Contact your nearest Onkyo service center.</li> <li>Decrease the volume, then disconnect the headphones.</li> </ul>	30 10–16 – 31
	No sound or very little sound is reproduced from the center speaker.	<ul style="list-style-type: none"> <li>The speakers are not properly connected.</li> <li>The listening mode is set to "Stereo" or "Orchestra."</li> <li>The volume level of the center speaker ("Center") is set to minimum.</li> <li>A speaker configuration without the center speaker is selected.</li> </ul>	<ul style="list-style-type: none"> <li>Check the speaker connections.</li> <li>No sound is reproduced from the center speaker when the listening mode is "Stereo" or "Orchestra."</li> <li>Adjust the volume level of the center speaker.</li> <li>Check that the selected speaker configuration includes the center speaker.</li> </ul>	13 36 19, 37 17
	No picture appears on the TV screen.	<ul style="list-style-type: none"> <li>The TV is not set to receive the output signals from the DVD Receiver.</li> <li>The video cable is not connected securely.</li> <li>Only the S video connection is made.</li> </ul>	<ul style="list-style-type: none"> <li>Set the TV to the DVD Receiver's input.</li> <li>Check the connections between the DVD Receiver and TV set.</li> <li>Also make video connection.</li> </ul>	– 10 10, 11
	The sound of the playback source is not heard.	<ul style="list-style-type: none"> <li>Another input source is selected.</li> </ul>	<ul style="list-style-type: none"> <li>Select the appropriate input source.</li> </ul>	28
	The buttons on the remote controller and DVD Receiver do not operate.	<ul style="list-style-type: none"> <li>Power supply fluctuations or other abnormalities such as static electricity may interrupt correct operation.</li> </ul>	<ul style="list-style-type: none"> <li>Switch off the main power, then switch it on again. If not recovered, disconnect the power cord (mains lead), then connect it again.</li> </ul>	16
DVD (VIDEO CD/Audio CD)	The DVD Receiver does not start playback.	<ul style="list-style-type: none"> <li>No disc is inserted.</li> <li>The region number of the disc is unmatched to the DVD Receiver.</li> <li>An unplayable disc is inserted.</li> <li>The disc is placed upside down.</li> <li>The disc is not placed within the disc tray guide.</li> <li>The disc is dirty.</li> <li>The parental lock function is activated.</li> </ul>	<ul style="list-style-type: none"> <li>Insert a disc. (Check that "DVD," "VCD," or "CD" is lit in the DVD Receiver's display.)</li> <li>See the rear panel of the unit to check the playable region number.</li> <li>Check the playable discs.</li> <li>Place the disc with the playback side down.</li> <li>Place the disc within the proper guide on the disc tray.</li> <li>Eject the disc and clean it.</li> <li>Deactivate the parental lock function or change the parental lock level.</li> </ul>	20 4 9 20 20 21, 9 56
	The DVD related operation buttons do not work.	<ul style="list-style-type: none"> <li>The SETUP button is pressed and the DVD Receiver stands by for the next function setting command.</li> </ul>	<ul style="list-style-type: none"> <li>Press SETUP once. If the buttons still don't work, press ▲.</li> </ul>	50, 21
	Brightness is unstable or noise is visible in the playback picture.	<ul style="list-style-type: none"> <li>Copy protection is activated.</li> </ul>	<ul style="list-style-type: none"> <li>Connect the DVD Receiver directly to the TV. Avoid connecting the DVD Receiver to the TV through a VCR.</li> </ul>	10
	The playback picture is occasionally distorted.	<ul style="list-style-type: none"> <li>The disc is dirty.</li> <li>It is in fast forward or fast reverse playback.</li> </ul>	<ul style="list-style-type: none"> <li>Eject the disc and clean it.</li> <li>Sometime a small amount of picture distortion may appear. This is not a malfunction.</li> </ul>	21, 9 22
	Playback doesn't follow the course of the disc's programs.	<ul style="list-style-type: none"> <li>The DVD Receiver is in repeat playback mode, memory playback mode, or random playback mode, etc.</li> </ul>	<ul style="list-style-type: none"> <li>Resume normal playback.</li> </ul>	39, 40, 41
	The picture from the DVD Receiver doesn't appear on the TV screen.	<ul style="list-style-type: none"> <li>The TV is not set to receive the output signals from the DVD Receiver.</li> </ul>	<ul style="list-style-type: none"> <li>Set the TV to the DVD Receiver's input.</li> </ul>	–
	No sound is reproduced.	<ul style="list-style-type: none"> <li>A wrong sound signal conversion method is selected.</li> </ul>	<ul style="list-style-type: none"> <li>Check the current sound signal conversion method, and select the right one.</li> </ul>	46, 54

# Troubleshooting

	Symptoms	Causes	Remedies	Pages
Tuner	Too much noise is heard or sound is interrupted occasionally. (The FM ST indicator does not light steadily.)	<ul style="list-style-type: none"> <li>FM stereo waves may produce a hiss noise when a certain level is reached.</li> <li>The position or direction of the FM antenna (aerial) is incorrect.</li> <li>The station is too weak.</li> </ul>	<ul style="list-style-type: none"> <li>Switch the frequency receiving mode to mono.</li> <li>Adjust the position, height, and direction of the FM antenna (aerial).</li> <li>Connect an FM outdoor antenna (aerial). Try to use an antenna (aerial) with more elements. [For installation of the outdoor antenna (aerial), consult your nearest dealer as it requires special skills and experience.]</li> </ul>	26 14 15
	Sound is distorted or sound volume decreases.	<ul style="list-style-type: none"> <li>The radio wave is distorted.</li> <li>Cars are running or airplanes are flying near the house.</li> </ul>	— —	— —
	Sound is excessively distorted.	<ul style="list-style-type: none"> <li>There is a tall building or a mountain nearby. [The waves transmitted from the transmission center (direct waves) and the waves reflected by buildings or mountains (diffraction waves) interfere with each other causing multi pass distortion.]</li> </ul>	—	—
	No preset channels are selected.	<ul style="list-style-type: none"> <li>The power cord (mains lead) is unplugged, or the main power is switched off, for a long time.</li> </ul>	<ul style="list-style-type: none"> <li>The preset data in memory is lost. Preset the radio stations again.</li> </ul>	26
Recording	Sound is reproduced from the speakers but not recorded.	<ul style="list-style-type: none"> <li>The sound system you are trying to record is DTS Surround.</li> <li>A wrong sound signal conversion method is selected.</li> </ul>	<ul style="list-style-type: none"> <li>DTS Surround sound is unable to be recorded regardless of the sound signal conversion method.</li> <li>Check the current sound signal conversion method and select the right one for recording.</li> </ul>	60 46, 54
Remote controller	The buttons on the DVD Receiver operate but the buttons on the remote controller do not operate.	<ul style="list-style-type: none"> <li>No batteries are inserted in the remote controller.</li> <li>The batteries are worn out.</li> <li>The remote controller is not pointed at the remote sensor of the DVD Receiver.</li> <li>The remote controller is too far from the DVD Receiver.</li> <li>Any wrong MODE button is pressed.</li> </ul>	<ul style="list-style-type: none"> <li>Insert new batteries.</li> <li>Replace with new batteries.</li> <li>Point the remote controller at the remote sensor of the DVD Receiver.</li> <li>Operate the remote controller within 5 m (16 feet).</li> <li>Press the appropriate MODE button.</li> </ul>	8 8 8 8 8

This unit contains a sensitive microcomputer, which under certain circumstances might fail to operate due to excessive noise interference. If this happens, press the DVD Receiver's SPEAKER A/B button and  $\odot$  STANDBY/ON button at the same time until "Clear" appears in the DVD Receiver's display. The DVD Receiver turns into the standby mode, then all the custom settings in the DVD Receiver's memory will be erased. Please repeat the custom settings from the beginning.



# Specifications

<b>AMPLIFIER SECTION</b>			
<b>Power Output (FTC)</b>	All channels 30 watts per channel min. RMS. into 6 ohms two channel driven, 1,000 Hz with no more than 0.6 % total harmonic distortion.	<b>Output Level and Impedance</b>	
<b>Continuous power output (DIN)</b>	All channels 30 watts per channel min. RMS. into 6 ohms two channel driven, 1,000 Hz	DIGITAL OUTPUT (OPT)	-21 to -15 dBm
<b>Total Harmonic Distortion</b>	0.6 % at rated power 0.2 % at 1 watt output	REC OUT (TAPE/MD, VIDEO 1)	200 mV, 2.2 kohms
<b>IM Distortion</b>	0.6 % at rated power 0.2 % at 1 watt output	PRE OUT (SUBWOOFER)	1 V, 2.2 kohms
<b>Damping Factor</b>	40 at 8 ohms	Composite (MON OUT, VIDEO 1)	1 Vp-p, 75 ohms
<b>Input Sensitivity and Impedance</b>		S-VIDEO (MON OUT, VIDEO 1)	Y: 1 Vp-p, 75 ohms C: 0.28 Vp-p, 75 ohms
VIDEO 1 DIGITAL INPUT (OPT)	-21 to -15 dBm	RGB video output	0.7 Vp-p, 75 ohms
VIDEO 2 DIGITAL INPUT (COAX)	0.5 Vp-p, 75 ohms	<b>Frequency Response</b>	20 to 30,000 Hz : +/- 0.8 dB
LINE (VIDEO 1, 2, TV/LINE, TAPE/MD)	200 mV/50 kohms	<b>Acoustic Control</b>	1: +6 dB at 40 Hz 2: +10 dB at 55 Hz +5 dB at 10,000 Hz
Composite (VIDEO 1, 2)	1 Vp-p, 75 ohms	<b>Signal-to-noise Ratio</b>	100 dB (IHF)
S-VIDEO (VIDEO 1, 2)	Y: 1 Vp-p, 75 ohms C: 0.28 Vp-p, 75 ohms	<b>Muting</b>	-∞ dB
<b>DVD SECTION</b>			
<b>Signal readout system</b>	Optical non-contact	<b>Frequency response</b>	4 Hz - 20 kHz (44.1 kHz), 4 Hz - 22 kHz (48 kHz), 4 Hz - 44 kHz (96 kHz)
<b>Linear velocity</b>	3.49 m/s (Single Layer), 3.84 m/s (Dual Layer)	<b>Wow and flutter</b>	Below threshold of measurability
<b>Error correction system</b>	Reed Solomon Product Code		
<b>Signal system</b>	PAL/3.58 NTSC		
<b>TUNER SECTION</b>			
<b>Tuning Range</b>	FM: 87.50 to 108.00 MHz (50 kHz steps) AM: 522 to 1611 kHz (9 kHz steps)		
<b>Usable Sensitivity</b>	FM: Mono 11.2 dBf, 1.0 μV (75 ohms IHF) 0.9 μV (75 ohms DIN) Stereo 17.2 dBf, 2.0 μV (75 ohms IHF) 23 μV (75 ohms DIN) AM: 30 μV		
<b>50 dB Quieting Sensitivity</b>	FM: Mono 17.2 dBf, 2.0 μV (75 ohms) Stereo 37.2 dBf, 20.0 μV (75 ohms)		
<b>Capture Ratio</b>	FM: 2.0 dB		
<b>Image Rejection Ratio</b>	FM: 85 dB AM: 40 dB		
<b>IF Rejection Ratio</b>	FM: 90 dB AM: 40 dB		
<b>Signal-to-noise Ratio</b>	FM: Mono 76 dB, IHF Stereo 70 dB, IHF AM: 40 dB		
<b>Alternate Channel Att. (+/- 400 kHz)</b>	FM: Mono 55 dB, IHF		
<b>Selectivity</b>	FM: 50 dB, DIN		
<b>AM Suppression Ratio</b>	FM: 50 dB		
<b>Harmonic Distortion</b>	FM: Mono 0.2 % Stereo 0.3 % AM: 0.7 %		
<b>Frequency response</b>	FM: 30 to 15,000 Hz (+/- 1.0 dB)		
<b>Stereo Separation</b>	FM: 45 dB at 1,000 Hz 30 dB at 100 to 10,000 Hz		
<b>Stereo Threshold</b>	FM: 17.2 dBf, 20 μV (75 ohms)		
<b>GENERAL</b>			
<b>Power Supply Rating</b>	AC 230-240 V, 50Hz	<b>Dimensions (W x H x D)</b>	435 × 101 × 428 mm (17 <sup>1</sup> / <sub>8</sub> × 4 × 16 <sup>7</sup> / <sub>8</sub> ins.)
<b>Power Consumption</b>	155 W	<b>Weight</b>	9.2 kg (20.3 lb.)

Specifications and features are subject to change without notice.

# Index to Parts and Controls

For operational instructions, refer to the page indicated in brackets.

## ■ Front panel and its display

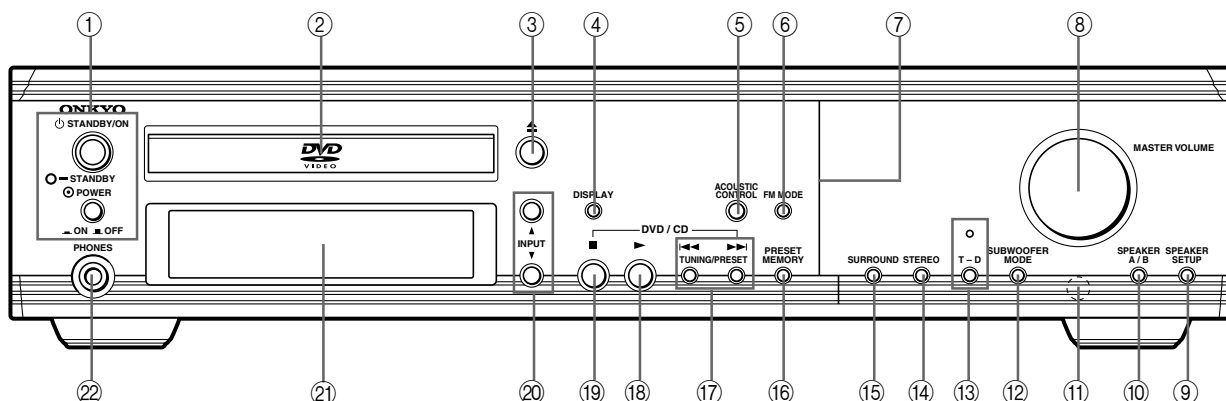

- |  |   |  |
|--|---|--|
| <ul style="list-style-type: none"> <li>① <b>STANDBY/ON</b> button, <b>STANDBY</b> indicator, <b>POWER</b> switch [16]</li> <li>② <b>Disc tray</b> [20]</li> <li>③ <b>▲ (open/close)</b> button [20, 21]</li> <li>④ <b>DISPLAY</b> button [48, 49]</li> <li>⑤ <b>ACOUSTIC CONTROL</b> button/indicator [38]</li> <li>⑥ <b>FM MODE</b> button [26]</li> <li>⑦ <b>Light</b> [16, 31]</li> </ul> | <ul style="list-style-type: none"> <li>⑧ <b>MASTER VOLUME</b> control [30]</li> <li>⑨ <b>SPEAKER SETUP</b> button [17]</li> <li>⑩ <b>SPEAKER A/B</b> button [30]</li> <li>⑪ <b>Remote control sensor</b> [8]</li> <li>⑫ <b>SUBWOOFER MODE</b> button [17]</li> <li>⑬ <b>T-D</b> button, indicator [35]</li> <li>⑭ <b>STEREO</b> button [36]</li> <li>⑮ <b>SURROUND</b> button [36]</li> </ul> | <ul style="list-style-type: none"> <li>⑯ <b>PRESET MEMORY</b> button [26, 27]</li> <li>⑰ <b>TUNING/PRESET</b> <b>◀◀/▶▶</b> buttons [25, 26, 27]</li> <li>⑱ <b>▶ (play)</b> button [20]</li> <li>⑲ <b>■ (stop)</b> button [21]</li> <li>⑳ <b>INPUT ▲/▼</b> buttons [26, 27, 28]</li> <li>㉑ <b>Display</b> [16, 31, below]</li> <li>㉒ <b>PHONES</b> jack [31]</li> </ul> |
|--|---|--|

## ■ Display

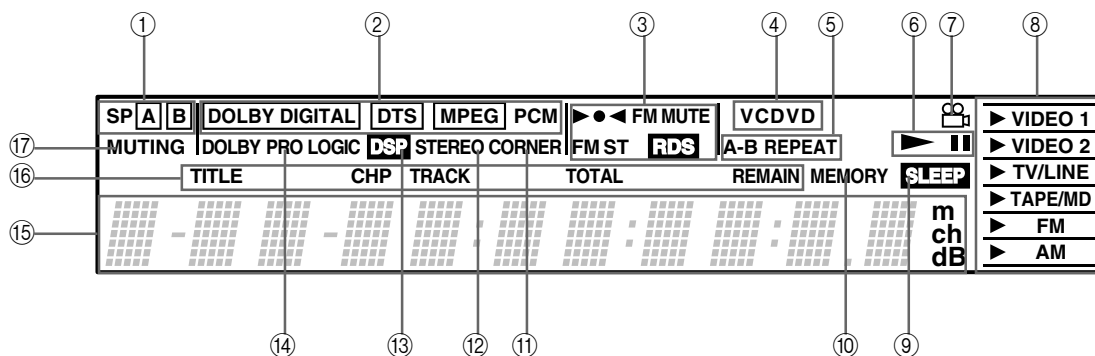

- |  |  |
|--|--|
| <ul style="list-style-type: none"> <li>① <b>SP A/B</b> indicators [30]</li> <li>② <b>Sound system</b> indicators [20, 28, 33]</li> <li>③ <b>Tuned, FM MUTE, FM ST, RDS</b> indicators [26, 27]</li> <li>④ <b>Inserted disc</b> indicator [20]</li> <li>⑤ <b>REPEAT/A-B REPEAT</b> indicators [39]</li> <li>⑥ <b>▶ (playing)/   (pausing)</b> indicators</li> <li>⑦ <b>Camera angle</b> indicator [43]</li> <li>⑧ <b>Input source</b> indicators [26, 27, 28]</li> <li>⑨ <b>SLEEP</b> indicator [31]</li> </ul> | <ul style="list-style-type: none"> <li>⑩ <b>MEMORY</b> indicator [40]</li> <li>⑪ <b>CORNER</b> indicator [34]</li> <li>⑫ <b>STEREO</b> indicator [36]</li> <li>⑬ <b>DSP</b> indicator [36]</li> <li>⑭ <b>DOLBY PRO LOGIC</b> indicator [36]</li> <li>⑮ <b>Multipurpose</b> display</li> <li>⑯ <b>TITLE, CHP, TRACK, TOTAL, REMAIN</b> indicators [48, 49]</li> <li>⑰ <b>MUTING</b> indicator [30]</li> </ul> |
|--|--|

## ■ Remote controller

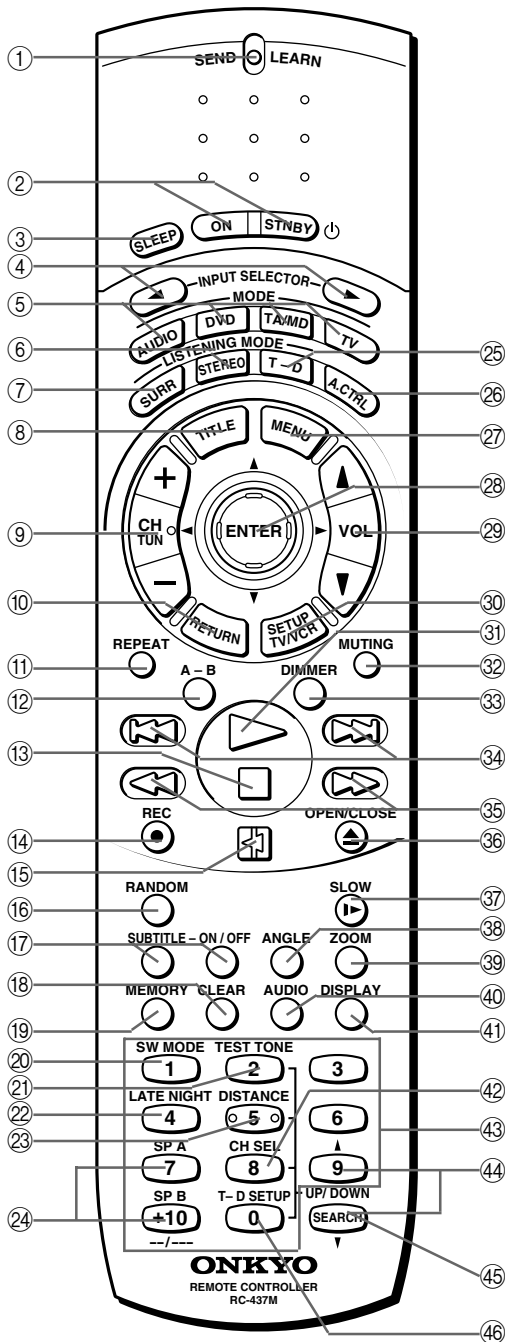

① SEND/LEARN indicator [8, 61, 62]

② ON button [16, 29, 61]  
STANDBY button [16]

③ SLEEP button [31]

④ INPUT SELECTOR buttons [27, 28]

⑤ MODE AUDIO, DVD, TA/MD, TV buttons [8]

⑥ STEREO button [36]

⑦ SURR button [36]

⑧ TITLE button [23]

⑨ CH TUN button [27, 29, 61]

⑩ RETURN button [40, 42, 50]

⑪ REPEAT button [29, 39, 40]

⑫ A-B button [39]

⑬ (stop) button [21, 29, 57]

⑭ REC (record) button [29]

⑮ (play pause) button [21, 29]

⑯ RANDOM button [41]

⑰ SUBTITLE/SUBTITLE-ON/OFF buttons [44]

⑱ CLEAR button [39–46]

⑲ MEMORY button [40]

⑳ SW MODE button [17]

㉑ TEST TONE button [19, 37]

㉒ LATE NIGHT button [38]

㉓ DISTANCE button [18]

㉔ SP A, SP B button [30]

㉕ T-D button [35]

㉖ A.CTRL button [38]

㉗ MENU button [23, 45]

㉘ Cursor (▲/▼/◀/▶/ENTER) [16, 20, 23, 40, 42–46, 50]

㉙ VOL ▲/▼ buttons [29, 30, 61]

㉚ SETUP button [16, 50]

TV/VCR button [29, 61]

㉛ (play) button [20, 29]

㉜ MUTING button [29, 30, 61]

㉝ DIMMER button [31]

㉞ (up) (down) button [25, 29, 41]

㉟ (fast reverse) (fast forward) buttons [22, 29]

㊱ OPEN/CLOSE/ (eject) button [20, 21, 29]

㊲ (slow playback) button [22]

㊳ ANGLE button [43]

㊴ ZOOM button [42]

㊵ AUDIO button [45, 46]

㊶ DISPLAY button [40, 48, 49]

㊷ CH SEL button [19, 37]

㊸ Number buttons [23–25, 29, 40, 41, 57]

㊹ UP ▲/DOWN ▼ buttons [18, 19, 35, 37]

㊺ SEARCH button [23, 25, 41, 61]

㊻ T-D SETUP button [35]

---

## **ONKYO CORPORATION**

Sales & Product Planning Div. : 2-1, Nisshin-cho, Neyagawa-shi, OSAKA 572-8540, JAPAN  
Tel: 072-831-8111 Fax: 072-833-5222

### **ONKYO U.S.A. CORPORATION**

200 Williams Drive, Ramsey, N.J. 07446, U.S.A.  
Tel: 201-825-7950 Fax: 201-825-8150 E-mail: onkyo@onkyousa.com

### **ONKYO EUROPE ELECTRONICS GmbH**

Industriestrasse 20, 82110 Germering, GERMANY  
Tel: 089-849-320 Fax: 089-849-3265 E-mail: info@onkyo.de

### **ONKYO CHINA LIMITED**

Units 2102-2107, Metroplaza Tower I, 223 Hing Fong Road, Kwai Chung,  
N.T., HONG KONG Tel: 852-2429-3118 Fax: 852-2428-9039



## Free Manuals Download Website

<http://myh66.com>

<http://usermanuals.us>

<http://www.somanuals.com>

<http://www.4manuals.cc>

<http://www.manual-lib.com>

<http://www.404manual.com>

<http://www.luxmanual.com>

<http://aubethermostatmanual.com>

Golf course search by state

<http://golfingnear.com>

Email search by domain

<http://emailbydomain.com>

Auto manuals search

<http://auto.somanuals.com>

TV manuals search

<http://tv.somanuals.com>