

ONKYO®

Contents

Before Using Your AV Receiver 2

Getting started

Turning on the AV Receiver/
Speaker Setup

Enjoying music or videos

Enjoying Surround mode/
Recording

Other

AV Receiver

TX-L5

Instruction Manual

Thank you for purchasing the Onkyo AV Receiver. Please read this manual thoroughly before making connections and turning on the power. Following the instructions in this manual will enable you to obtain optimum performance and listening enjoyment from your new AV Receiver. Please retain this manual for future reference.

WARNING:

TO REDUCE THE RISK OF FIRE OR ELECTRIC SHOCK, DO NOT EXPOSE THIS APPLIANCE TO RAIN OR MOISTURE.

CAUTION:

TO REDUCE THE RISK OF ELECTRIC SHOCK, DO NOT REMOVE COVER (OR BACK).
NO USER-SERVICEABLE PARTS INSIDE.
REFER SERVICING TO QUALIFIED SERVICE PERSONNEL.

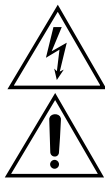

The lightning flash with arrowhead symbol, within an equilateral triangle, is intended to alert the user to the presence of uninsulated "dangerous voltage" within the product's enclosure that may be of sufficient magnitude to constitute a risk of electric shock to persons.

The exclamation point within an equilateral triangle is intended to alert the user to the presence of important operating and maintenance (servicing) instructions in the literature accompanying the appliance.

Important Safeguards

- 1. Read Instructions** – All the safety and operating instructions should be read before the appliance is operated.
- 2. Retain Instructions** – The safety and operating instructions should be retained for future reference.
- 3. Heed Warnings** – All warnings on the appliance and in the operating instructions should be adhered to.
- 4. Follow Instructions** – All operating and use instructions should be followed.
- 5. Cleaning** – Unplug the appliance from the wall outlet before cleaning. The appliance should be cleaned only as recommended by the manufacturer.
- 6. Attachments** – Do not use attachments not recommended by the appliance manufacturer as they may cause hazards.
- 7. Water and Moisture** – Do not use the appliance near water –for example, near a bath tub, wash bowl, kitchen sink, or laundry tub; in a wet basement; or near a swimming pool; and the like.
- 8. Accessories** – Do not place the appliance on an unstable cart, stand, tripod, bracket, or table. The appliance may fall, causing serious injury to a child or adult, and serious damage to the appliance. Use only with a cart, stand, tripod, bracket, or table recommended by the manufacturer, or sold with the appliance. Any mounting of the appliance should follow the manufacturer's instructions, and should use a mounting accessory recommended by the manufacturer.
- An appliance and cart combination should be moved with care. Quick stops, excessive force, and uneven surfaces may cause the appliance and cart combination to overturn.
- 10. Ventilation** – Slots and openings in the cabinet are provided for ventilation and to ensure reliable operation of the appliance and to protect it from overheating, and these openings must not be blocked or covered. The openings should never be blocked by placing the appliance on a bed, sofa, rug, or other similar surface. The appliance should not be placed in a built-in installation such as a bookcase or rack unless proper ventilation is provided. There should be free space of at least 20 cm (8 in.) and an opening behind the appliance.
- 11. Power Sources** – The appliance should be operated only from the type of power source indicated on the marking label. If you are not sure of the type of power supply to your home, consult your appliance dealer or local power company.
- 12. Grounding or Polarization** – The appliance may be equipped with a polarized alternating current line plug (a plug having one blade wider than the other). This plug will fit into the power outlet only one way. This is a safety feature. If you are unable to insert the plug fully into the outlet, try reversing the plug. If the plug should still fail to fit, contact your electrician to replace your obsolete outlet. Do not defeat the safety purpose of the polarized plug.
- 13. Power-Cord Protection** – Power-supply cords should be routed so that they are not likely to be walked on or pinched by items placed upon or against them, paying particular attention to cords at plugs, convenience receptacles, and the point where they exit from the appliance.
- 14. Outdoor Antenna Grounding** – If an outside antenna or cable system is connected to the appliance, be sure the antenna or cable system is grounded so as to provide some protection against voltage surges and built-up static charges. Article 810 of the National Electrical Code, ANSI/NFPA 70, provides information with regard to proper grounding of the mast and supporting structure, grounding of the lead-in wire to an antenna-discharge unit, size of grounding conductors, location of antenna-discharge unit, connection to grounding electrodes, and requirements for the grounding electrode. See Figure 1.
- 15. Lightning** – For added protection for the appliance during a lightning storm, or when it is left unattended and unused for long periods of time, unplug it from the wall outlet and disconnect the antenna or cable system. This will prevent damage to the appliance due to lightning and power-line surges.
- 16. Power Lines** – An outside antenna system should not be located in the vicinity of overhead power lines or other electric light or power circuits, or where it can fall into such power lines or circuits. When installing an outside antenna system, extreme care should be taken to keep from touching such power lines or circuits as contact with them might be fatal.
- 17. Overloading** – Do not overload wall outlets, extension cords, or integral convenience receptacles as this can result in a risk of fire or electric shock.
- 18. Object and Liquid Entry** – Never push objects of any kind into the appliance through openings as they may touch dangerous voltage points or short-out parts that could result in a fire or electric shock. Never spill liquid of any kind on the appliance.
- 19. Servicing** – Do not attempt to service the appliance yourself as opening or removing covers may expose you to dangerous voltage or other hazards. Refer all servicing to qualified service personnel.
- 20. Damage Requiring Service** – Unplug the appliance from the wall outlet and refer servicing to qualified service personnel under the following conditions:
 - When the power-supply cord or plug is damaged,
 - If liquid has been spilled, or objects have fallen into the appliance,
 - If the appliance has been exposed to rain or water,
 - If the appliance does not operate normally by following the operating instructions. Adjust only those controls that are covered by the operating instructions as an improper adjustment of other controls may result in damage and will often require extensive work by a qualified technician to restore the appliance to its normal operation,
 - If the appliance has been dropped or damaged in any way, and
 - When the appliance exhibits a distinct change in performance – this indicates a need for service.

PORTABLE CART WARNING



S3125A

21. **Replacement Parts** – When replacement parts are required, be sure the service technician has used replacement parts specified by the manufacturer or have the same characteristics as the original part. Unauthorized substitutions may result in fire, electric shock, or other hazards.
22. **Safety Check** – Upon completion of any service or repairs to the appliance, ask the service technician to perform safety checks to determine that the appliance is in proper operation condition.
23. **Wall or Ceiling Mounting** – The appliance should be mounted to a wall or ceiling only as recommended by the manufacturer.
24. **Heat** – The appliance should be situated away from heat sources such as radiators, heat registers, stoves, or other appliances (including amplifiers) that produce heat.

FIGURE 1:
EXAMPLE OF ANTENNA GROUNDING AS PER NATIONAL ELECTRICAL CODE, ANSI/NFPA 70

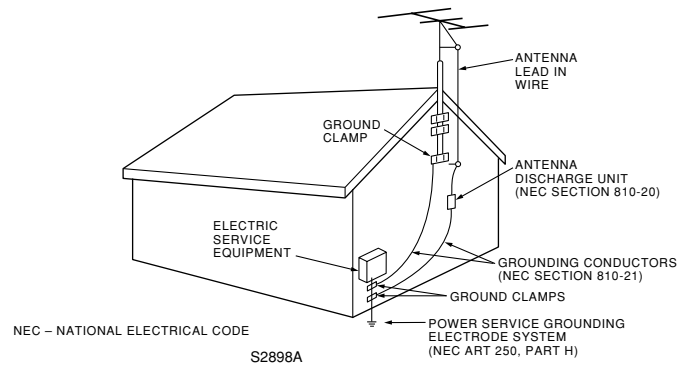

Precautions

■ For British models

Replacement and mounting of an AC plug on the power supply cord of this unit should be performed only by qualified service personnel.

IMPORTANT

The wires in the mains lead are coloured in accordance with the following code:

- Blue : Neutral
- Brown : Live

As the colours of the wires in the mains lead of this apparatus may not correspond with the coloured markings identifying the terminals in your plug, proceed as follows:

The wire which is coloured blue must be connected to the terminal which is marked with the letter N or coloured black.
The wire which is coloured brown must be connected to the terminal which is marked with the letter L or coloured red.

IMPORTANT

A 5 ampere fuse is fitted in this plug. Should the fuse need to be replaced, please ensure that the replacement fuse has a rating of 5 amperes and that it is approved by ASTA or BSI to BS1362. Check for the ASTA mark or the BSI mark on the body of the fuse.
IF THE FITTED MOULDED PLUG IS UNSUITABLE FOR THE SOCKET OUTLET IN YOUR HOME THEN THE FUSE SHOULD BE REMOVED AND THE PLUG CUT OFF AND DISPOSED OF SAFELY. THERE IS A DANGER OF SEVERE ELECTRICAL SHOCK IF THE CUT OFF PLUG IS INSERTED INTO ANY 13 AMPERE SOCKET.

If in any doubt, consult a qualified electrician.

■ For U.S. models

Note to CATV system installer:

This reminder is provided to call the CATV system installer's attention to Section 820-40 of the NEC which provides guidelines for proper grounding and, in particular, specifies that the cable ground shall be connected to the grounding system of the building, as close to the point of cable entry as practical.

FCC Information for User

CAUTION:

The user changes or modifications not expressly approved by the party responsible for compliance could void the user's authority to operate the equipment.

NOTE:

This equipment has been tested and found to comply with the limits for a Class B digital device, pursuant to Part 15 of the FCC Rules. These limits are designed to provide reasonable protection against harmful interference in a residential installation. This equipment generates, uses and can radiate radio frequency energy and, if not installed and used in accordance with the instructions, may cause harmful interference to radio communications. However, there is no guarantee that interference will not occur in a particular installation. If this equipment does cause harmful interference to radio or television reception, which can be determined by turning the equipment off and on, the user is encouraged to try to correct the interference by one or more of the following measures:

- Reorient or relocate the receiving antenna.
- Increase the separation between the equipment and receiver.
- Connect the equipment into an outlet on a circuit different from that to which the receiver is connected.
- Consult the dealer or an experienced radio/TV technician for help.

■ For Canadian models

NOTE: THIS CLASS B DIGITAL APPARATUS COMPLIES WITH CANADIAN ICES-003.

For models having a power cord with a polarized plug:

CAUTION: TO PREVENT ELECTRIC SHOCK, MATCH WIDE BLADE OF PLUG TO WIDE SLOT, FULLY INSERT.

■ Modele pour les Canadien

REMARQUE: CET APPAREIL NUMÉRIQUE DE LA CLASSE B EST CON-FORME À LA NORME NMB-003 DU CANADA.

Sur les modèles dont la fiche est polarisée:

ATTENTION: POUR ÉVITER LES CHOCs ÉLECTRIQUES, INTRODUIRE LA LAME LA PLUS LARGE DE LA FICHE DANS LA BORNE CORRESPONDANTE DE LA PRISE ET POUSSER JUSQU'AU FOND.

Declaration of Conformity

We, ONKYO EUROPE
ELECTRONICS GmbH
INDUSTRIESTRASSE 20
82110 GERMERING,
GERMANY



declare in own responsibility, that the ONKYO product described in this instruction manual is in compliance with the corresponding technical standards such as EN60065, EN55013, EN55020 and EN61000-3-2, -3-3.

GERMERING, GERMANY

I. MORI

ONKYO EUROPE ELECTRONICS GmbH

Precautions

1. Recording Copyright

Recording of copyrighted material for other than personal use is illegal without permission of the copyright holder.

2. AC Fuse

The fuse is located inside the chassis and is not user-serviceable. If power does not come on, contact your Onkyo authorized service station.

3. Care

From time to time you should wipe the front and rear panels and the cabinet with a soft cloth. For heavier dirt, dampen a soft cloth in a weak solution of mild detergent and water, wring it out dry, and wipe off the dirt. Following this, dry immediately with a clean cloth. Do not use rough material, thinners, alcohol or other chemical solvents or cloths since these could damage the finish or remove the panel lettering.

4. Power

WARNING

BEFORE PLUGGING IN THE UNIT FOR THE FIRST TIME, READ THE FOLLOWING SECTION CAREFULLY.

The voltage of the available power supply differs according to country or region. Be sure that the power supply voltage of the area where this unit will be used meets the required voltage (e.g., AC 230 V, 50 Hz or AC 120 V, 60 Hz) written on the rear panel.

Worldwide models are equipped with a voltage selector to conform to local power supplies. Be sure to set this switch to match the voltage of the power supply in your area before plugging in the unit.

Features

Amplifier Features

- **Rated output power (6 ohms, 1 kHz, 0.6% THD):**
Front 22 W + 22 W, center 22 W, surround 22 W + 22 W
- **24-bit DSP chip featuring high-speed processing and excellent reliability**
- **Stabilized ground potential, which is the basis of audio signal amplitudes**
- **Dolby* Digital & Dolby Pro Logic II decoder and DTS** decoder**
- **Acoustic Control function**
- **Subwoofer pre-output**
- **Five sets of audio input connectors and three sets of audio output connectors**
- **S-Video input/output**
- **Heat-resistance, slim power transformer**
- **Large extruded-aluminum heat sinks**
- **Three digital input connectors**
- **Onkyo-original surround modes with five sophisticated modes (Orchestra, Unplugged, Studio Mix, TV Logic and All Channel Stereo) for natural audio reproduction**
- **Late Night function**

FM/AM Tuner Features

- **30 FM/AM random presets**
- **FM auto tuning**
- **FM indoor antenna supplied**
- **AM indoor antenna supplied**

* Manufactured under license from Dolby Laboratories. "Dolby", "Pro Logic" and the double-D symbol are trademarks of Dolby Laboratories. Confidential Unpublished Works. ©1992-1997 Dolby Laboratories. All rights reserved.

** Manufactured under license from Digital Theater Systems, Inc. US Pat. No.5,451,942 and other worldwide patents issued and pending, "DTS" and "DTS Digital Surround" are trademarks of Digital Theater Systems, Inc. ©1996 Digital Theater Systems, Inc. All Rights reserved.

Memory Preservation

This unit does not require memory preservation batteries. A built-in memory power backup system preserves the contents of memory during power failures and even when the POWER switch is set to OFF.

The POWER switch must be set to ON in order to charge the backups system. The memory preservation period after the unit has been turned off varies depending on climate and placement of the unit. On average, memory contents are protected over a period of a few weeks after the time the unit has been turned off. This period is shorter when the unit is exposed to a very humid climate.

Table of Contents

Important Safeguards/Precautions/Features/Table of Contents	2–5
---	-----

Getting Started

Supplied Accessories	6
Preparing the Remote Controller	7
Index to Parts and Controls	8
Connecting to Audio/Video Equipment	12
Positioning Speakers	14
Connecting Speakers	15
Making Antenna (Aerial) Connections	16
Connection for remote control (RI)	18

Turning on the AV Receiver/Speaker Setup

Connecting the Power/Turning on the AV Receiver	19
Speaker Setup	20

Enjoying music or videos

Listening to the Radio	23
Playing the Connected Source	26
Various Functions Common to all the Sources	28

Enjoying Surround mode/Recording

Enjoying the Surround Modes	30
Recording a source	35

Other

Troubleshooting	36
Specifications	38
Memo	39

Supplied Accessories

Make sure your box contains everything listed below.
If any pieces are missing, contact your nearest Onkyo dealer.

The number of accessories is indicated in brackets.

Remote controller (RC-453S) [1]

Batteries (size AA/R6/UM3) [2]

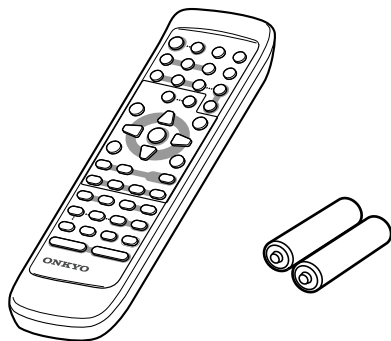

FM antenna (aerial) [1]

(USA and Canadian models)



(Other models)

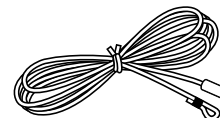

AM loop antenna (aerial) [1]

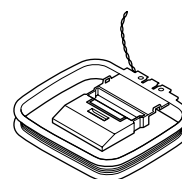

FM outdoor antenna (aerial) adapter [1]

(Supplied only for Asian and Austrarian models)

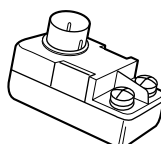

Preparing the Remote Controller

Inserting the Batteries

① Detach the battery cover.

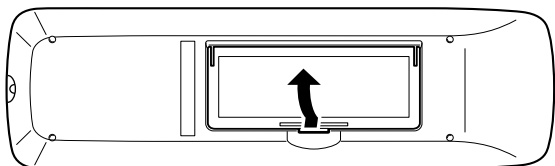

② Insert the two size AA/R6/UM3 batteries.

Be sure to match the + and - ends of the batteries with the diagram inside the battery compartment.

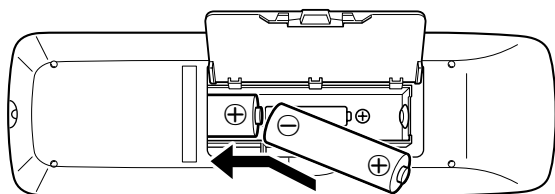

③ Attach the battery cover.

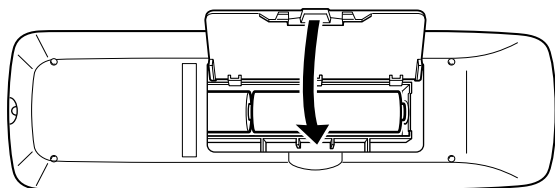

Notes

- Do not mix new batteries with old batteries or different kinds of batteries.
- To avoid corrosion, remove the batteries if the remote controller is not to be used for a long time.
- Remove dead batteries immediately to avoid damage from corrosion. If the remote controller does not operate smoothly, replace both batteries at the same time.
- The life of the supplied batteries is about six months but this varies depending on usage.

Using the Remote Controller

Point the remote controller toward the remote control sensor.

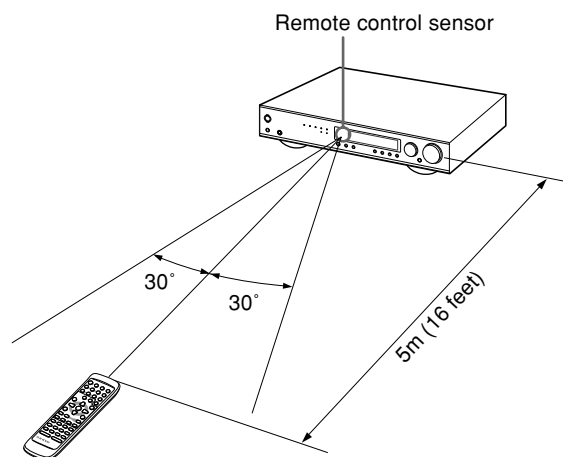

Notes

- Place the unit away from strong light such as direct sunlight or inverted fluorescent light which can prevent proper operation of the remote controller.
- Using another remote controller of the same type in the same room or using the unit near equipment which uses infrared rays may cause operational interference.
- Do not put any object (such as a book) on the remote controller. The buttons of the remote controller may be pressed by mistake and drain the batteries.
- Make sure the audio rack doors do not have colored glass. Placing the unit behind such doors may prevent proper remote controller operation.
- If there is any obstacle between the remote controller and the remote control sensor, the remote controller will not operate.

Index to Parts and Controls

For operational instructions, refer to the page indicated in brackets.

■ Front panel

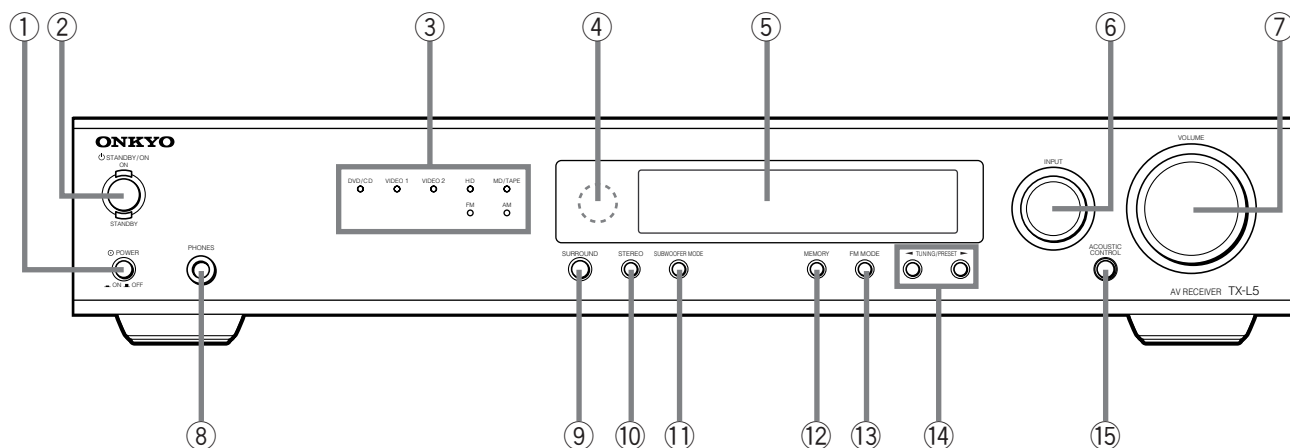

① POWER switch [19]

Turns on the main power supply for the TX-L5. The TX-L5 enters standby state and the STANDBY indicator lights up. Pressing the switch again to the off position (■ OFF) shuts down the main power supply into the TX-L5.

- Before turning on the power, make sure all cables are properly connected.
- Turning on the TX-L5 may cause a momentary power surge that might interfere with other electrical equipment on the same circuit. If this is a problem, plug the TX-L5 into a different electrical circuit.

② STANDBY/ON button, ON indicator, STANDBY indicator [19]

When STANDBY/ON button is pressed to ON while the POWER switch is set to ON, the display will light to show the current volume setting for about 5 seconds then show the current sound input source and listening mode. Pressing the button again returns the TX-L5 to the standby state. This state turns off the display, disables control functions.

③ Source indicators [23, 26]

One of these indicators lights to show the current source.

④ Remote control sensor [7]

This sensor receives the control signals from the remote controller.

⑤ Display [9]

⑥ INPUT dial [23, 26, 35]

The INPUT dial is used to select the input source.

⑦ VOLUME dial [23, 26]

The VOLUME dial is used to control the volume level. Turn the dial clockwise to increase the volume level and counterclockwise to decrease it.

⑧ PHONES jack [29]

This is a standard stereo jack for connecting stereo headphones. The audio for the front right and left speakers are sent to the headphone speakers. When the headphones are plugged in, the listening mode automatically changes to STEREO and sounds are not output from the speakers.

⑨ SURROUND button [32]

Press this button to select a surround mode for current input source.

⑩ STEREO button [32]

Press this button to change the sound to stereo.

⑪ SUBWOOFER MODE button [20]

Press to select the subwoofer mode.

⑫ MEMORY button [24, 25]

This button is used to assign the radio station that is currently tuned in to a preset channel or delete a previously preset station.

⑬ FM MODE button [23, 25]

Press to switch the reception mode between stereo and monaural. If audio is interrupted or noise interferes with audio during FM stereo broadcasting, press this button to switch to the monaural reception mode.

⑭ TUNING/PRESET ◀▶ button [23, 24]

Use these buttons to change the tuner frequency. The tuner frequency is displayed in the front display and it can be changed in 50 kHz increments for FM and 10 kHz (or 9 kHz) increments for AM. Also, These buttons make it possible to store desired radio stations under the desired preset numbers and recall them with an easy operation.

⑮ ACOUSTIC CONTROL button/indicator [34]

Press to change the acoustic mode to enjoy more dynamic sounds by boosting the super bass/high frequency sounds.

For operational instructions, refer to the page indicated in brackets.

■ Display

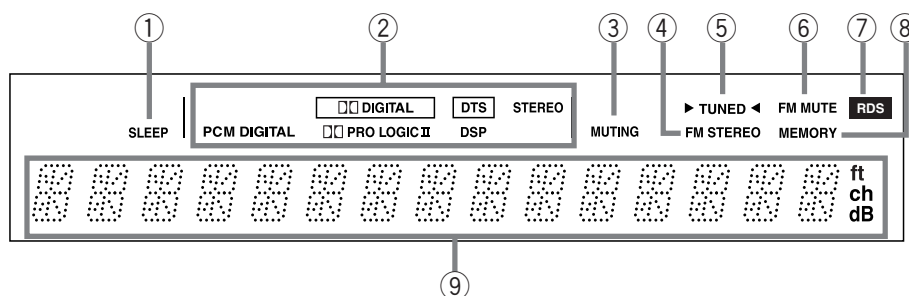

① SLEEP indicator [29]

Lights up when the sleep timer is active.

② Source/Listening mode indicators [26, 32]

One of these indicators lights to show the format of the current source as "PCM DIGITAL", "DIGITAL" or "DTS". In addition, one of the listening mode indicators "PRO LOGIC II", "DSP" and "STEREO" lights according to the current listening mode.

③ MUTING indicator [29]

Flashes when the mute function is active.

④ FM STEREO indicator [23]

Lights up when an FM stereo broadcast station is received.

⑤ TUNED indicator [23]

Lights up when a radio station is received.

⑥ FM MUTE indicator [23]

Lights up to indicate FM muting. It extinguishes when the monaural reception mode is started by pressing the FM MODE button.

⑦ RDS indicator (European models only) [23]

Lights up when a RDS station is received.

⑧ MEMORY indicator [24]

Lights up when the MEMORY button is pressed in the radio station preset operation.

⑨ Multi function display

In usual operation, shows the current input source and volume. When the FM or AM input is selected, it shows the frequency and preset number. When the DISPLAY button is pressed, it shows the listening mode and input source format. However, it does not show the source format when the input source signal is analog, or when the FM or AM source is selected.

Index to Parts and Controls

For operational instructions, refer to the page indicated in brackets.

■ Rear panel

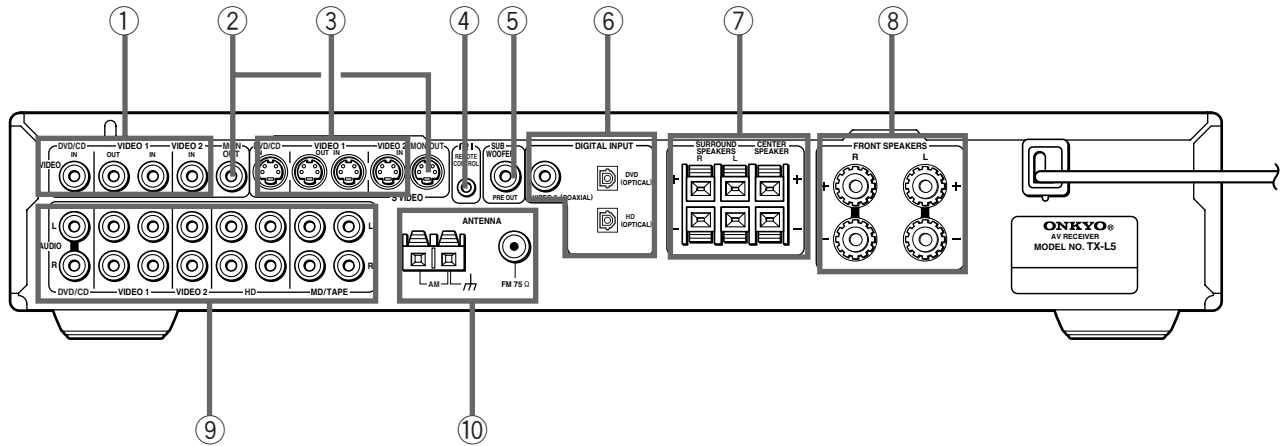

① VIDEO (DVD/CD IN / VIDEO 1 OUT/IN / VIDEO 2 IN) [13]

There are 3 video inputs and 1 output. Connect DVD players, LD players, VCRs or other video components to the video inputs. The video output channel can be used to be connected to video tape recorder for making recordings.

② MON OUT [12]

The monitor output includes both RCA type and S video configurations. This output is for connecting television monitors or projectors.

③ S VIDEO (DVD/CD IN / VIDEO 1 OUT/IN / VIDEO 2 IN) [13]

There are 3 video inputs and 1 output. Connect DVD players, LD players, VCRs or other video components to the video inputs. The video output channel can be used to be connected to video tape recorder for making recordings.

④ RI (REMOTE CONTROL) [18]

Connect the Onkyo components that have **RI** connectors such as a CD player, and cassette tape deck using the **RI** cables provided with them. When these components are interconnected, they can be controlled from the remote controller provided with the TX-L5. After connecting the **RI** connectors, check the operation of the remote controller buttons for use in controlling other components (refer to page 27).

- The **RI** connectors are only effective if they are used in conjunction with an Onkyo amplifier with an **RI** connector. Do not connect to a component other than Onkyo component with an **RI** connector. Doing so may damage the TX-L5.
- Connecting **RI** cable only does not make the system operational. You must also connect the audio cables as well.
- If the connected component has two **RI** connectors, you can use either one to connect to the TX-L5. The other one can be used to daisy chain with another component.

⑤ SUB WOOFER PRE OUT [15]

This terminal is for connecting an active subwoofer.

⑥ DIGITAL INPUT (DVD, HD (OPTICAL), VIDEO 2 (COAXIAL)) [12, 13]

These are the digital audio inputs. There are 2 digital inputs with optical jacks and 1 with a coaxial jack. The inputs accept digital audio signals from DVD players, hard disk recorders, CD players, or other digital source component.

⑦ SURROUND SPEAKERS L/R, CENTER SPEAKER [15]

Speaker terminals are provided for the center, surround left and surround right speakers.

⑧ FRONT SPEAKERS L/R [15]

Speaker terminals are provided for the front left, front right speakers. Speaker outputs are compatible with banana plug connectors (other than European models).

⑨ AUDIO L/R (DVD/CD IN / VIDEO 1 OUT/IN / VIDEO 2 IN / HD OUT/IN / MD/TAPE OUT/IN) [12, 13]

These are the analog audio inputs and outputs. There are 5 audio inputs and 3 audio outputs. The audio inputs and outputs require RCA type connectors. When connecting a VCR or other video component, make sure you connect the audio and video leads together (i.e., both to VIDEO 1).

⑩ ANTENNA [16, 17]

These terminals are for connecting the FM antenna and AM antenna.

For operational instructions, refer to the page indicated in brackets.

■ Remote Controller

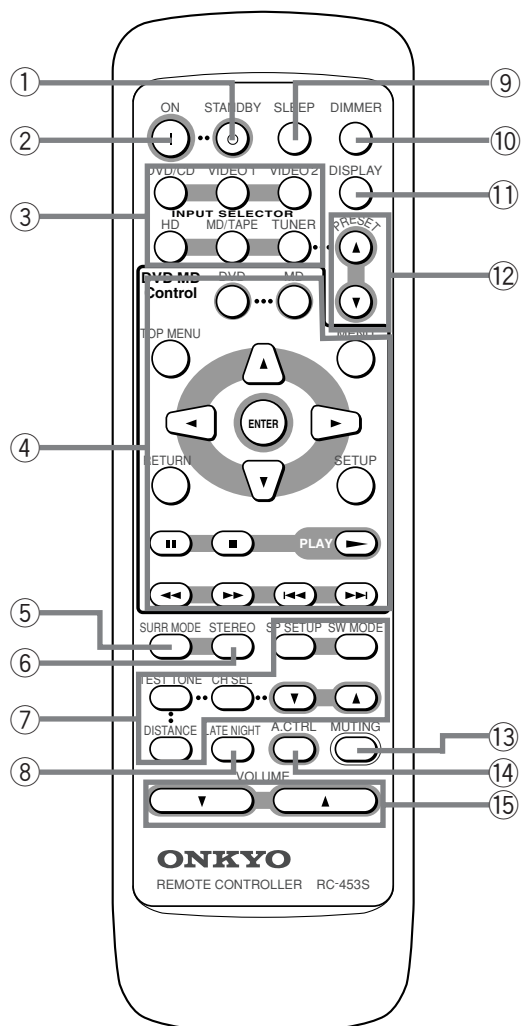

For detailed descriptions on the buttons, see “Front panel facilities” on pages 8.

- ① **STANDBY button [19]**
Put the TX-L5 in standby.
- ② **ON button [19]**
Turns on the TX-L5.
- ③ **INPUT SELECTOR buttons [26, 27, 35]**
For selecting the input source.
- ④ **DVD•MD Control buttons [27]**
For operating **RI**-connected Onkyo components connected to the TX-L5.
- ⑤ **SURR MODE button [32]**
Press to select the surround mode.
- ⑥ **STEREO button [32]**
Press to change the listening mode to stereo.
- ⑦ **SP SETUP/SW MODE/TEST TONE/CH SEL/DISTANCE/▲/▼ buttons [20-22, 33]**
For setting the output levels for each speaker.
These buttons are provided only on the remote controller.
- ⑧ **LATE NIGHT button [34]**
Press to change the late night setting.
This button is provided only on the remote controller.
- ⑨ **SLEEP button [29]**
For setting the sleep timer.
This button is provided only on the remote controller.
- ⑩ **DIMMER button [28]**
For adjusting the brightness of the front display.
This button is provided only on the remote controller.
- ⑪ **DISPLAY button [28]**
For changing the display.
- ⑫ **PRESET ▲/▼ button [24]**
For selecting a tuner preset channel.
- ⑬ **MUTING button [29]**
Activates the mute function.
This button is provided only on the remote controller.
- ⑭ **A.CTRL button [34]**
Press to change the acoustic mode to boost the super bass/high frequency sounds.
- ⑮ **VOLUME ▲/▼ button [26]**
For adjusting the volume.

Connecting to Audio/Video Equipment

Before connecting

- Refer also to the instruction manual of each component to be connected.
- When you connect the AV Receiver to audio/video equipment, be sure to turn off the power and unplug all the units from the mains before making any connections.
- **About DIGITAL INPUT (OPTICAL) jack**
Remove the protective caps before making connections. When not in use, be sure to replace them.

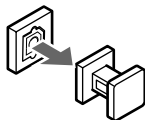

- Connect the plugs securely.
- **About the DVD, VIDEO 1 and VIDEO 2 jacks**
The video input/output connections are also necessary even if you make the S video input/output connections.

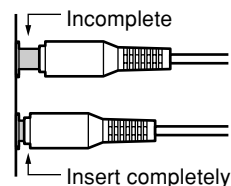

Example of monitor and audio equipment connections

Note

The signal that comes in from S VIDEO IN is sent to S VIDEO OUT. The signal that comes in from VIDEO IN is sent to VIDEO OUT.

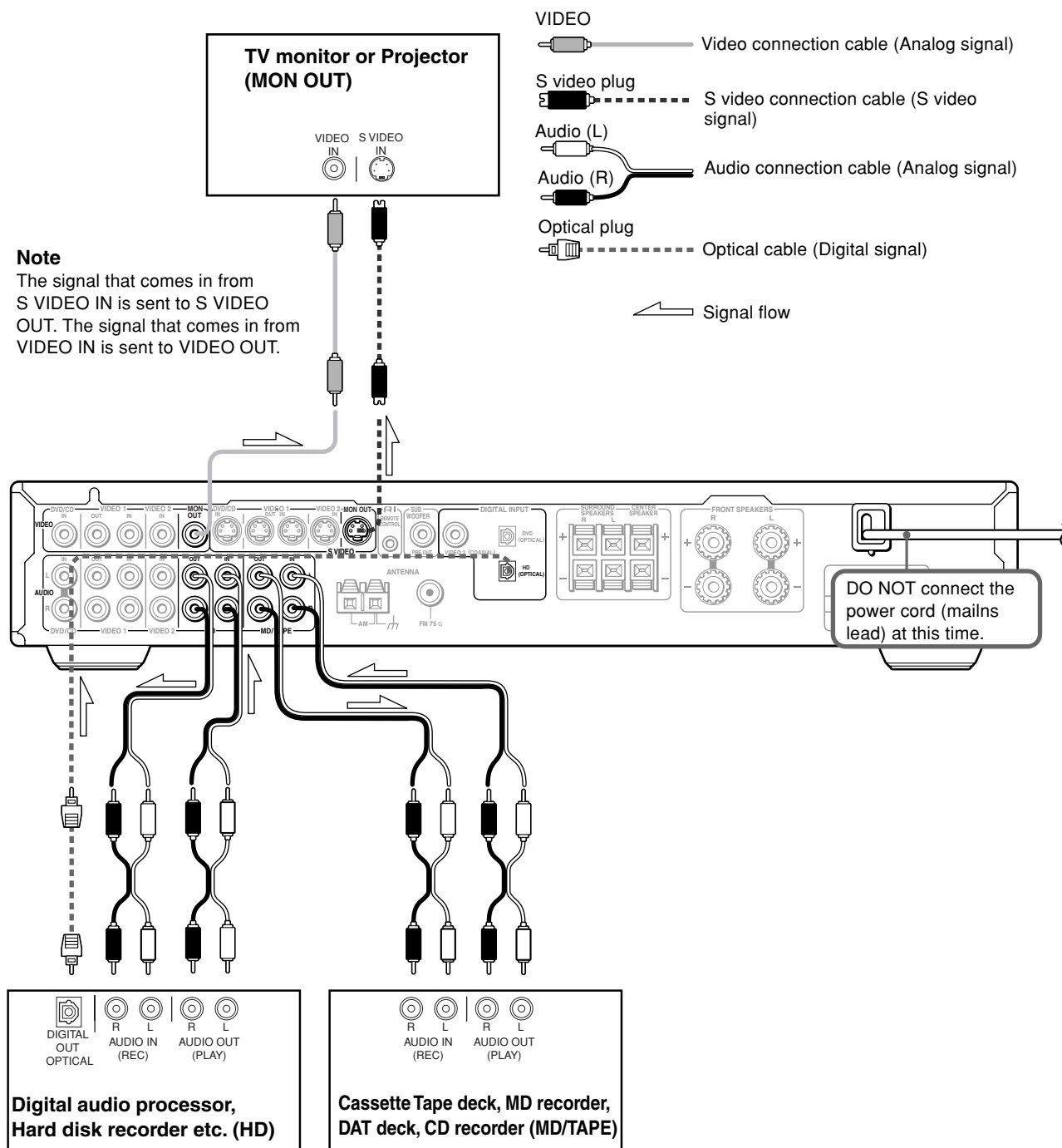

Example of video equipment connections

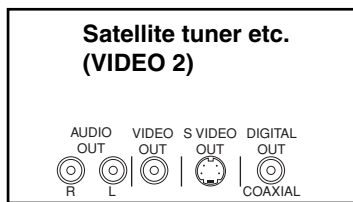

* If you have an LD player with AC-3RF output, connect via an AC-3RF demodulator to one of the TX-L5's DIGITAL INPUT terminals.

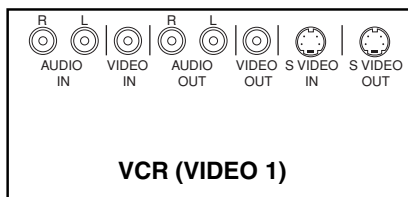
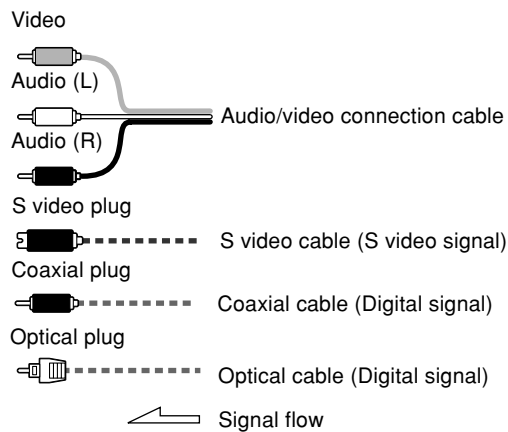
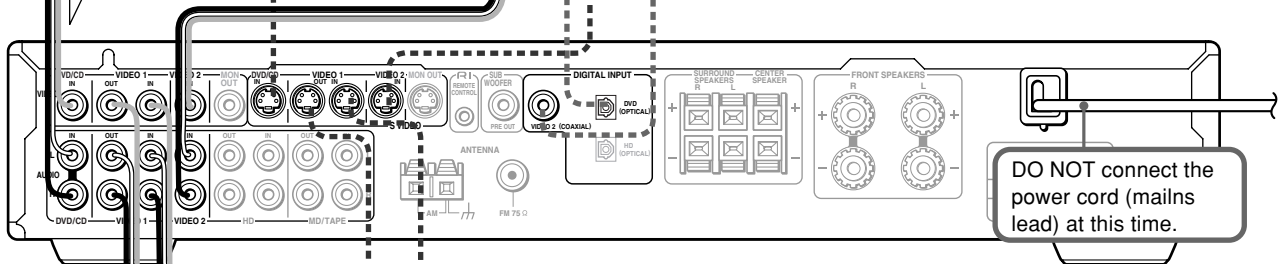

Positioning Speakers

The front left, center, and right speakers, surround left and right speakers, and subwoofer can be connected to the AV receiver.

You can reproduce the sounds such as Dolby surround and DTS surround.

■ Standard speaker placement

Speaker placement plays an important role in the reproduction of Surround sound.

The placement of the speakers varies depending on the size of the room and the wall coverings used in the room. The illustration below shows an example of a layout for standard speaker placement. Refer to this example when you position the speakers in order to experience the best of Surround sound.

For ideal Surround effects, all speakers should be installed.

If a center speaker or subwoofer is not connected, the sound from the unused channel is properly distributed to the connected speakers in order to reproduce the best Surround sound possible.

Front

The center speaker reproduces a richer sound image by enhancing the perception of the sound's source and movement.

The left, right, and center speakers should face the seated listener and be placed at ear level.

Surround

The surround speakers reproduce the feel of a moving sound while creating the sensation of being in the middle of the action.

Place the left and right surround speakers 1 meter (3 feet) above the listener's ear level and facing toward the sides of the room, making sure that the listener is within the speakers' dispersion angle.

Subwoofer

Install a subwoofer with a built-in power amplifier for powerful bass sounds.

The placement of the subwoofer does not affect the final quality of the sound image much, therefore, you can install it wherever it is convenient.

Refer to the speakers' instruction manuals for details.

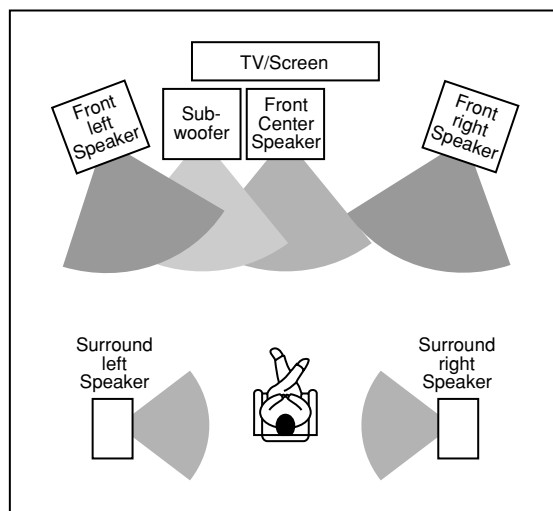

Connecting Speakers

Before connecting

- Refer also to the instruction manuals of the speakers.
- Be sure to connect the positive and negative cables for the speakers properly. If they are mixed up, the left and right signals will be reversed and the audio will sound unnatural.
- Connect speakers with an impedance between 6 Ω and 16 Ω . Connecting speakers with an impedance less than 6 Ω may damage the TX-L5.
- To prevent damage to circuits, never short-circuit the positive (+) and negative (-) speaker wires.

- Do not connect more than one speaker cable to one speaker terminal. Doing so may damage the TX-L5.
- When you are using only one speaker or when you wish to listen to monaural (mono) sound, a single speaker should never be connected in parallel to both the right and left channel terminals simultaneously.

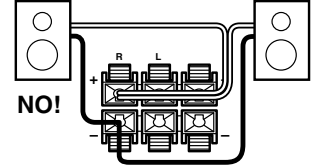
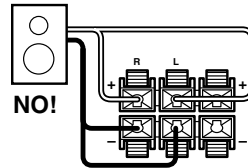

Connecting to SPEAKER terminals

How to connect to the FRONT SPEAKERS terminals

15 mm ($\frac{5}{8}$ ")



Strip 15 mm ($\frac{5}{8}$ ") from the end of each cable, then twist the exposed wires tightly.

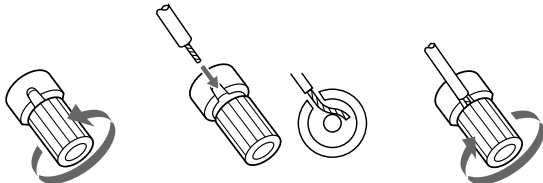

Loosen the screw.

Fully insert the end of the cable.

Tighten the screw.

How to connect to the SURROUND SPEAKERS and CENTER SPEAKER terminals

10 mm ($\frac{3}{8}$ ")

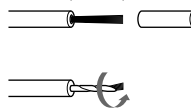

Strip 10 mm ($\frac{3}{8}$ ") from the end of each cable, then twist the exposed wires tightly.

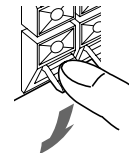

Press and hold the lever.

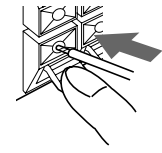

Insert the stripped end of the cable. By releasing the lever, the lever is replaced.

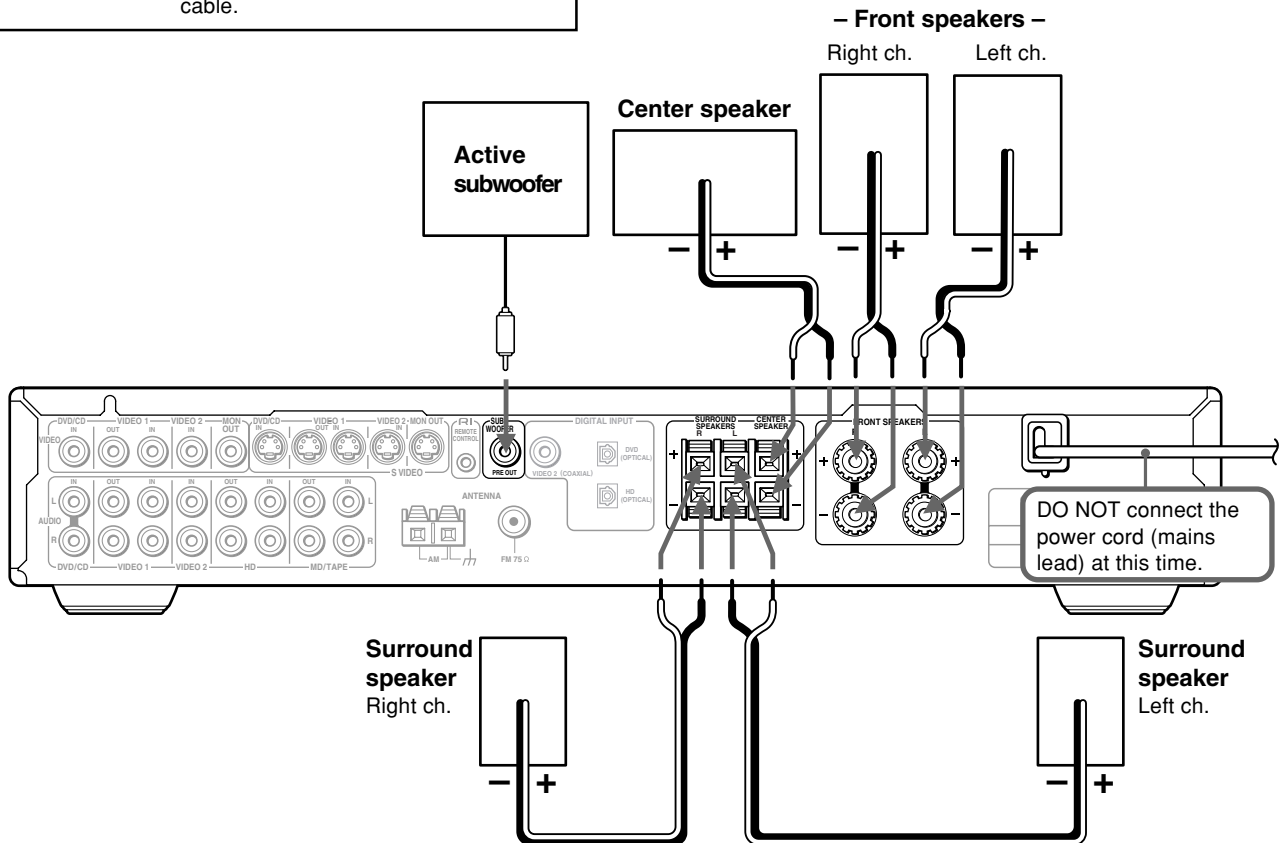

Making Antenna (Aerial) Connections

Connecting the Supplied FM and AM Indoor Antennas (Aerials)

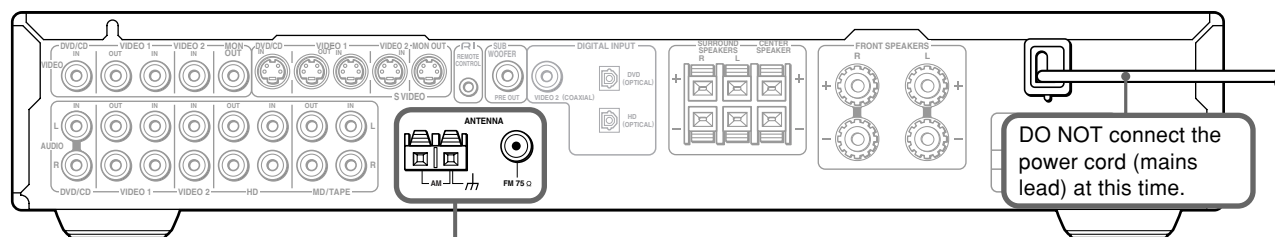

North American models:

- 1 Strip away the insulation from the end of the cord.

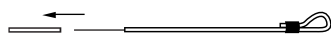

- 2 Fully insert the stripped end of the cord.

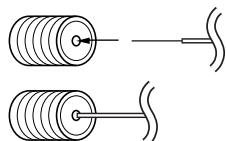

Except for North American models:

Fully insert the end of the cord.

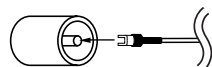

FM indoor antenna (aerial)

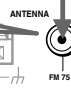

■ Adjusting the position of the FM indoor antenna (aerial)

The FM indoor antenna is for indoor use only. During use, extend the antenna and move it in various directions until the clearest signal is received. Fix it with push pins or similar implements in the position that will cause the least amount of distortion.

If the reception is not very clear with the attached FM indoor antenna, the use of an outdoor antenna is recommended.

Rotate the outer frame of the antenna.

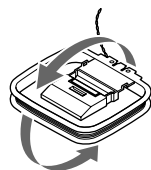

Insert into the hole.

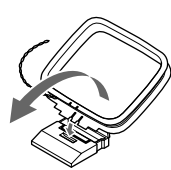

Extend the antenna cord.

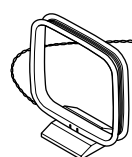

AM indoor antenna (aerial)



Note

Insert one end of the AM antenna (aerial) cord to either of the AM antenna (aerial) connectors and the other end to the other connector. There is no difference between one end of the AM antenna (aerial) cord and the other end, unlike the speaker cables which have positive and negative poles.

Press up and hold the lever.



Insert the end of the cord.

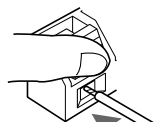

Release the lever to secure the connection.

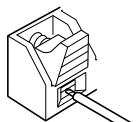

■ Adjusting the position of the AM indoor antenna (aerial)

The AM loop antenna is for indoor use only. Set it in the direction and position where you receive signals clearly. Put it as far away as possible from the TX-L5, televisions, speaker cables, and power cords.

When reception is not satisfactory with the attached AM loop antenna alone, connection of an outdoor antenna is recommended.

Connecting an FM Outdoor Antenna (Aerial)

If the FM reception is not very clear with the supplied antenna (aerial), connect an FM outdoor antenna (aerial) instead of the indoor FM antenna (aerial).

FM outdoor antenna (aerial)

Connecting coaxial cable to a 75/300 ohm antenna (aerial) adapter*

① Strip the end of the coaxial cable.

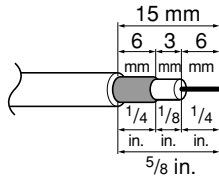

② With your fingernail or a small screwdriver, press the stoppers outward and remove the cover.

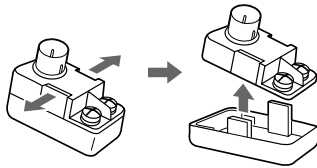

③ Remove the transformer wire A from slit B and insert it into slit C.

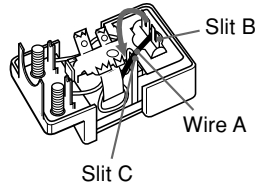

④ Insert the end of the cable.
⑤ Clamp it in place with pliers.

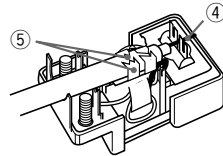

⑥ Reinstall the cover.

Connecting 300 ohm ribbon wire to a 75/300 ohm antenna (aerial) adapter*
Loosen the screws and wrap the wire around these screws. Then tighten the screws with a screwdriver.

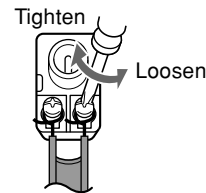

* (European, USA and Canadian models)
Not supplied
(Other models)
Supplied

Notes

- Install the antenna (aerial) well away from tall buildings and in an area where FM stations can directly be received.
- Keep the antenna (aerial) away from noise sources (neon signs, busy roads, etc.).
- It is dangerous to put the antenna (aerial) close to power lines. Keep it well away from power lines, transformers, etc.
- To avoid the risk of lightning and electrical shock, grounding is necessary. Follow item 14 of the "Important Safeguards" on page 2 when you install the outdoor antenna (aerial).

Connecting an AM Outdoor Antenna (Aerial)

An outdoor antenna (aerial) will be more effective if it is stretched horizontally above a window or outside.
Leave the supplied AM indoor antenna (aerial) connected.

Note

To avoid the risk of lightning and electrical shock, grounding is necessary. Follow item 14 of the "Important Safeguards" on page 2 when you install an outdoor antenna (aerial).

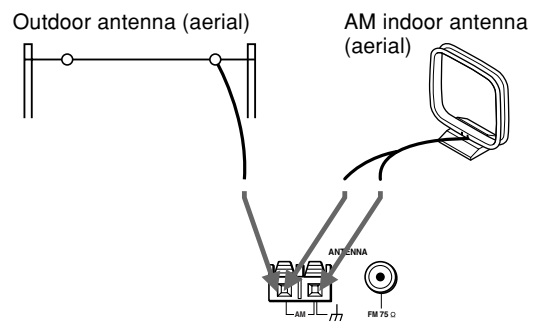

Directional linkage

Do not use the same antenna (aerial) for both FM and TV (or VCR) reception since the FM and TV (or VCR) signals can interfere with each other. If you must use a common FM/TV (or VCR) antenna (aerial), use a directional linkage type splitter.

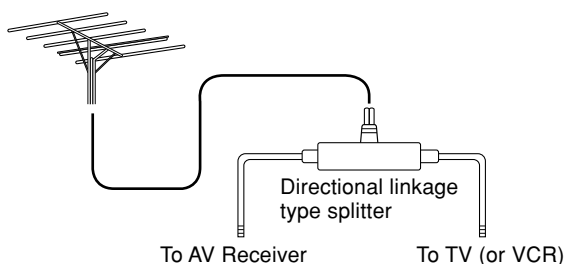

Connections for remote control (RI)

You can use the remote controller of this receiver to operate the RI-connected Onkyo DVD player, CD player, MD recorder or cassette tape deck using the RI cable provided with them (refer to page 27).

Example: Onkyo DVD Player DV-L5

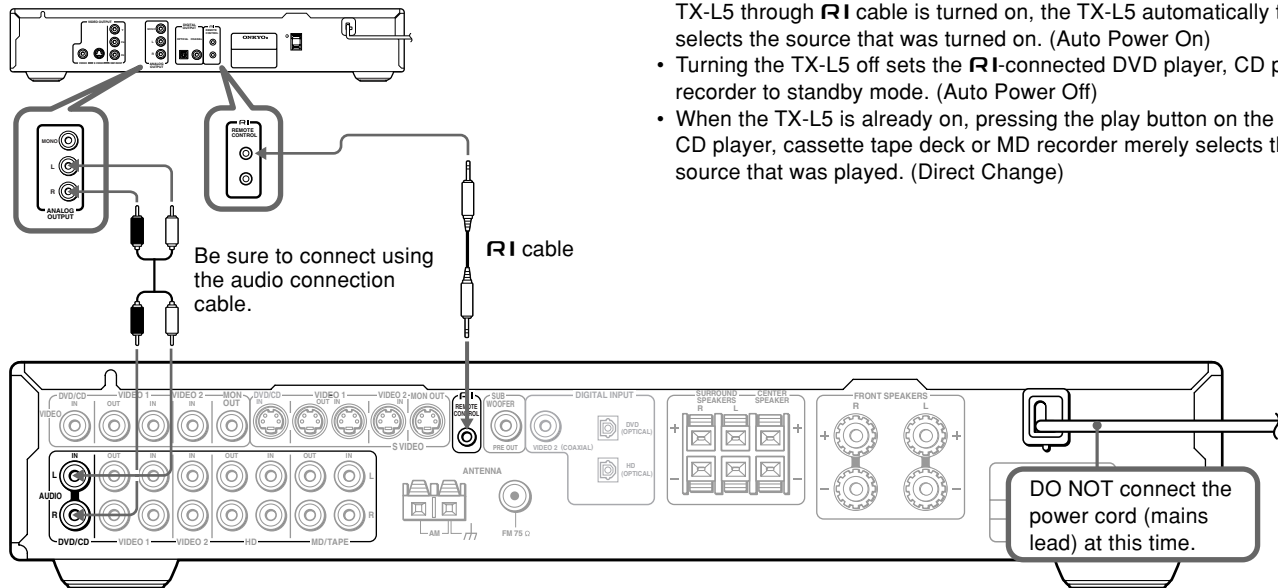

Notes

- When the DVD player, CD player or MD recorder connected to with the TX-L5 through RI cable is turned on, the TX-L5 automatically turns on and selects the source that was turned on. (Auto Power On)
- Turning the TX-L5 off sets the RI-connected DVD player, CD player or MD recorder to standby mode. (Auto Power Off)
- When the TX-L5 is already on, pressing the play button on the DVD player, CD player, cassette tape deck or MD recorder merely selects the input source that was played. (Direct Change)

- Connect the cassette tape deck to the MD/TAPE jacks. In this case, switch the source from MD to TAPE (refer to page 27).
- Connect the CD player to the DVD/CD jacks. In this case, switch the source from DVD to CD (refer to page 27).

Notes

- Do not connect the Onkyo MD recorder, CD recorder and cassette tape deck with the RI cable at the same time. This may lead to unexpected operation.
- Connect the plugs securely.
- Be sure to connect to the RI connectors using the RI cable.
- The connections on pages 12 and 13 are needed even if RI connection is made.
- Do not connect the AV Receiver's RI connector to any component other than an Onkyo product. It may cause malfunction.
- Certain component models may not be able to control the TX-L5.

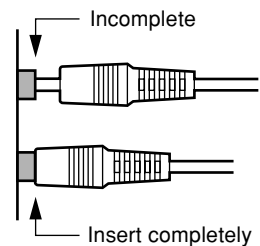

Connecting the Power/ Turning on the AV Receiver

Before connecting

- Make sure that all the connections from pages 10 to 16 are complete.
- Turning on the AV Receiver may cause a momentary power surge, which might interfere with other electrical equipment such as computers. If this happens, use a wall outlet on a different circuit.

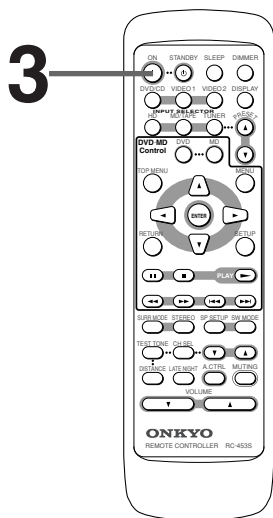
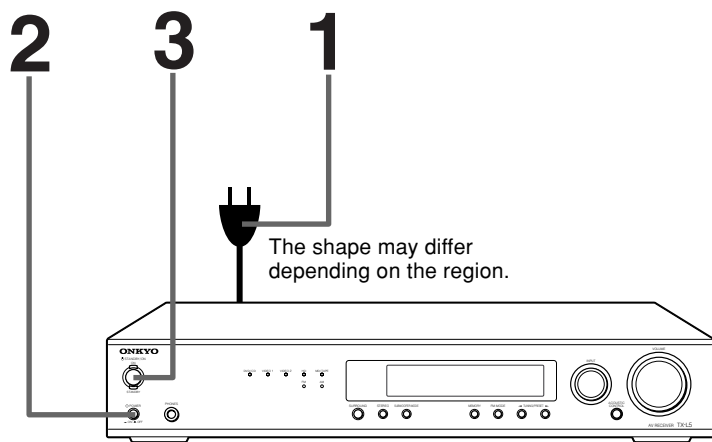

1 Connect the power cord (mains lead) to a wall outlet (the mains).

2 Press **⊖ POWER** switch to switch on the main power.
The TX-L5 enters standby mode.
The STANDBY indicator lights up.



Notes

- The TX-L5 is shipped with the main power (**⊖ POWER**) switch in the on position (**⊖**) ON.
- To switch off the main power, press the **⊖ POWER** switch again.
- The buttons on the remote controller don't operate if the **⊖ POWER** switch is set to OFF.

3 Press **⏻ STANDBY/ON** on the AV Receiver or **ON** on the remote controller.

The AV Receiver turns on.
The ON indicator and display on the AV Receiver's front panel light. At the same time, the STANDBY indicator goes off.



Notes

- When the Onkyo DVD player, CD player, MD recorder and cassette tape deck are **RI**-connected, pressing ON button on the remote controller turns on the **RI**-connected components.
- To turn off the AV Receiver, press **⏻ STANDBY/ON** on the AV Receiver, or **STANDBY** on the remote controller. The AV Receiver enters standby mode. Be sure to set the volume to minimum before turning off the AV receiver.

Speaker Setup

You need to setup the speaker configuration for the speaker system connected to the **SPEAKER** terminals. It is not necessary to set the parameters again once you have completed the setup unless you change the speaker configuration.

Note

Speakers setup cannot be done if headphones are connected.

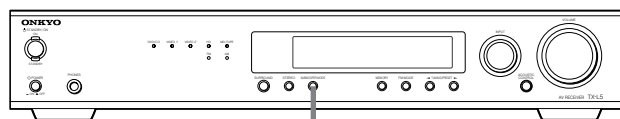

SUBWOOFER MODE

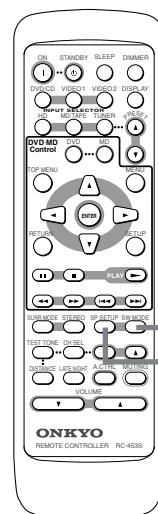

SW MODE

SP SETUP

Selecting the number of speaker channels

SP SETUP



Press **SP SETUP** repeatedly to select the number of channels within 3 seconds.

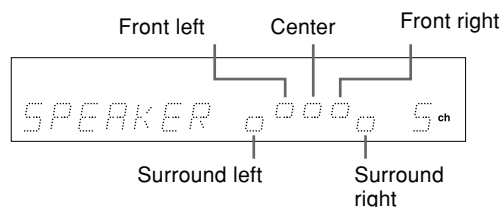

Display and number of speaker channels

00000 5ch	Speaker 5ch
0 0 2ch	Speaker 2ch
000 3ch	Speaker 3ch
00 00 4ch	Speaker 4ch

The normal display resumes in 3 seconds

Notes

- The listening mode will automatically change according to the number of channels if you set the number of channels.
- With the first press of **SP SETUP**, you can check the present setting. Then each press of the button changes the number of channels.

Setting the Subwoofer Mode

Unit

SUBWOOFER MODE



Remote controller

SW MODE



Press **SUBWOOFER MODE** on the unit or **SW MODE** on the remote controller.

SUBWOOFER MODE 1

With the first press of the button, you can check the present setting. Then each press of the button changes the subwoofer mode as follows (a tip on how to select the right subwoofer mode is in parentheses):

- SUBWOOFER OFF
(When no subwoofer is connected)
- ↓
- SUBWOOFER MODE 1
(When you want to enhance the super bass)
- ↓
- SUBWOOFER MODE 2
(When you want to lower the super bass)

The normal display resumes in three seconds.

Before starting the procedure below, measure the distances from each speaker to the listening position. For pair speakers such as front left and right speakers, the distance from the listening position to one speaker should be the same as the distance to the other. In the procedure below, select the values which approximate the actual distances.

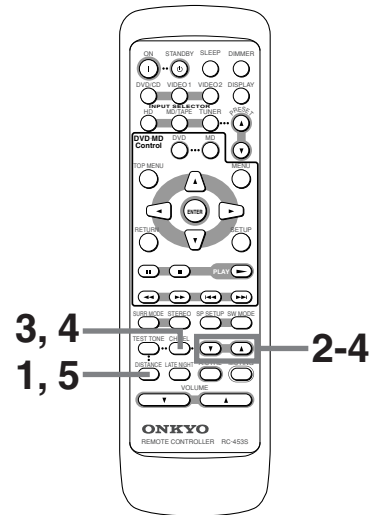

Setting the Distance From the Listening Position to Each Speaker

1 **DISTANCE**

Press DISTANCE.
The distance entry display for the front left and right speakers appears.

FRONT =3.6m / 12"

2

Press ▲/▼ to select the front left and right speaker distance.
You can select a distance between 0.3 m and 9 m (1 ft. and 30 ft.).

FRONT =4.2m / 14"

3 **CH SEL**

Press CH SEL, then press ▲/▼ repeatedly to select the center speaker distance.

CENTER =3.3m / 11"

You cannot enter the following distances:

- Distances longer than the distance set for the front speakers.
- Distances shorter than the distance obtained by subtracting "1.5 m (5 ft.)" from the distance entered for the front speakers.

Note

If you selected a speaker configuration with no center speaker on the previous page, this step will be skipped.

4 **CH SEL**

Press CH SEL, then press ▲/▼ repeatedly to select the surround left and right speaker distance.

SURR =3.3m / 11"

You cannot enter the following distances:

- Distances longer than the distance set for the front speakers.
- Distances shorter than the distance obtained by subtracting "4.5 m (15 ft.)" from the distance entered for the front speakers.

Note

If you selected a speaker configuration with no surround speakers on the previous page, this step will be skipped.

5 **DISTANCE**

Press DISTANCE.
The normal display resumes.

Speaker Setup

Adjust each speaker's relative volume balance so that the volumes of all speakers' test tones sound equal at the listening position.

Note

You cannot adjust the volume balance while the muting function is activated.

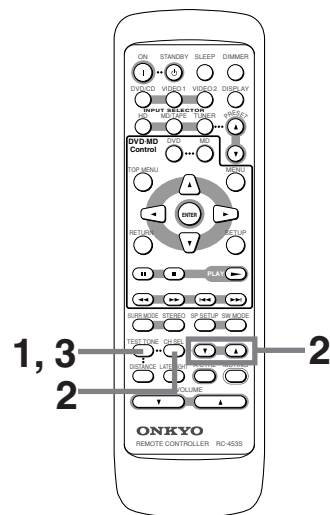

Adjusting Each Speaker's Relative Volume Balance – Test Tone



1 Press TEST TONE.

Each speaker emits the test tone (pink noise) and the display shows the speaker emitting the test tone in the following order:

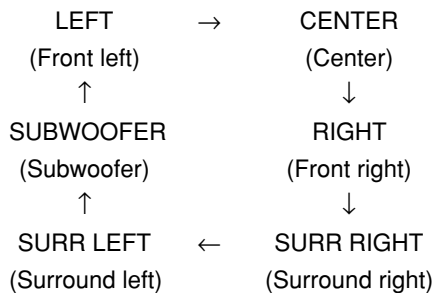

Notes

- No test tone will be emitted from the speaker which is not included in the speaker configuration on page 20 even if it is actually connected.
- No test tone will be emitted from the subwoofer when the subwoofer mode is set to "SUBWOOFER OFF".



2

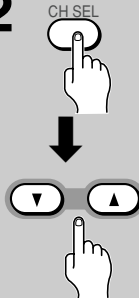

Press CH SEL repeatedly to select the speaker, then press ▲/▼ to adjust the volume level.

The volume level can be adjusted between -12dB and +12dB.

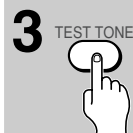

3

When you have completed the adjustment by repeating step 2, press TEST TONE.

The test tone stops and the normal display resumes.

Note

Even if you don't press TEST TONE, the test tone will stop after 2 minutes.

Listening to the Radio

There are two ways to select radio stations:

- Manual tuning
- Presetting radio stations then selecting the preset channels

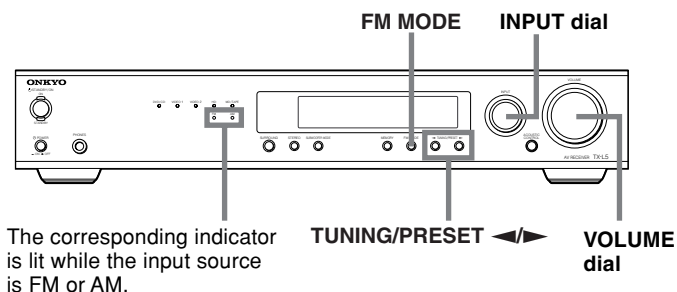

Tuning Manually

1 Turn **INPUT** dial to select the band (FM or AM).
e.g. When FM is selected.

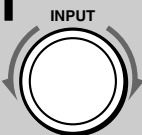
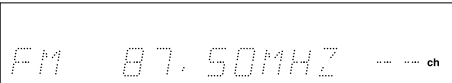
2 Turn **VOLUME** dial to adjust the volume.

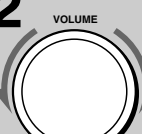

3 Press and hold **TUNING/PRESET** for about 1.5 seconds.
Appears when a broadcast is received.

When the band is FM
Auto tuning starts. The frequency changes in 50 kHz steps.
When a broadcast is received, scanning stops and the frequency flashes in the display.

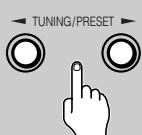
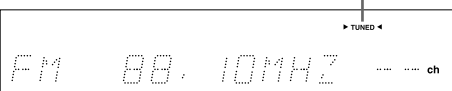
When the band is AM
The frequency changes as follows:
– (USA and Canadian models)
In 10 kHz steps
– (Other models)
In 9 kHz steps

When you release the button, the frequency stops changing and flashes in the display.

Note

If you press and hold TUNING/PRESET short time, the AV receiver enters the selecting preset stations mode. Refer to "Selecting Preset Stations" on page 24.

4 While the frequency is flashing (for about 3 seconds), press **TUNING/PRESET** to change the frequency.

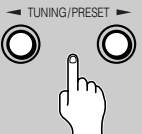

- The frequency changes each time you press TUNING/PRESET.
- You can change the frequency as long as the frequency in the display is flashing. Each press of either button causes the frequency to flash for about 3 seconds.

■ Tuning in a weak frequency (only for FM stations)

When you tune in a stereo FM station, the FM STEREO indicator lights up if the signal is sufficiently strong.



If the signal is weak, you may not be able to tune to the station. In this case, press FM MODE. The FM MUTE indicator goes off.

Then select the station to which you want to listen. (At this time, the station will be in mono and interstation noise will be heard.)



■ Receiving RDS (European models only)

When an Radio Data System (RDS) station broadcasting Program Service Name (PS) information is received, the RDS indicator lights up and the name of the station is displayed.

- RDS reception is only available on the European models, and only in areas where RDS broadcasts are available.



Listening to the Radio

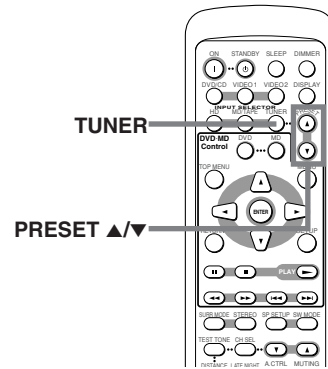
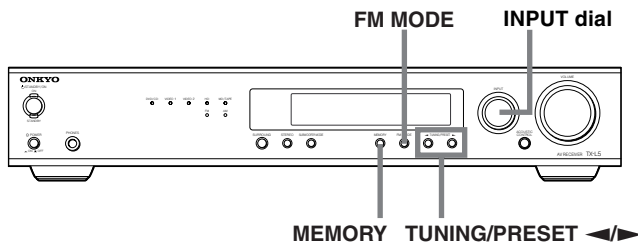

Presetting Radio Stations

You can preset up to 30 stations.

1	<p>Tune in the radio station you wish to preset (refer to the previous page).</p>
2	<p>Press MEMORY.</p> <p>The MEMORY indicator lights and the preset number starts flashing in the display.</p>
3	<p>While the MEMORY indicator is lit (for about 8 seconds), press TUNING/PRESET ◀▶ to select the preset number.</p>
4	<p>Press MEMORY.</p> <p>The radio station is registered to the preset channel.</p> <p>To register another preset station, repeat steps 1 to 4.</p>

Note

When you preset either FM station or AM station only, you cannot switch the band to another band (for example AM to FM) with the remote controller. Turn INPUT dial to select the band.

Selecting Preset Stations

Before selecting preset stations, you need to preset the radio stations. See "Presetting Radio Stations" on the left column of this page.

1	<p>Remote controller</p> <p>TUNER</p>	<p>Press TUNER on the remote controller or rotate the INPUT dial on the unit to switch the input source to the tuner.</p> <p>"FM" or "AM" appears in the display.</p> <p>The band selected in this step will not affect the next step.</p>
2	<p>Remote controller</p> <p>PRESET ▲/▼</p>	<p>Press PRESET ▲/▼ on the remote controller or TUNING/PRESET ◀▶ on the unit repeatedly to select the preset number of the desired radio station.</p>
	<p>Unit</p> <p>TUNING/PRESET ◀▶</p>	<p>Note</p> <p>If you press TUNING/PRESET ◀▶ on the unit for more than 1.5 seconds, the unit enters the manual tuning mode. See step 2 in "Tuning Manually" on the previous page.</p>

Erasing a Preset Station

1

Select the preset channel you wish to erase (see steps in the previous page).

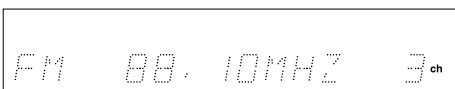

FM 88.10MHz 3^{ch}

2

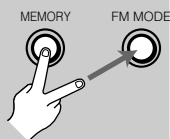

Press FM MODE while holding down MEMORY.

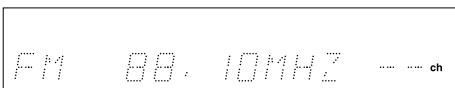

FM 88.10MHz --^{ch}

The selected preset channel will be erased.

Various Functions While Listening to Radio Programs

To use the following functions, see pages 28 and 29.

- Changing the Display
- Controlling the Brightness of the Lights on the AV receiver
- Muting the Sound
- Listening Through Headphones
- Using the Sleep Timer

Enjoying the Surround Modes While Listening to Radio Programs

See page 30.

Playing the Connected Source

This section shows you how to play the sources connected to the AV Receiver. You may need to see "Connecting to Audio/Video Equipment" on page 12 while following the steps in this section.

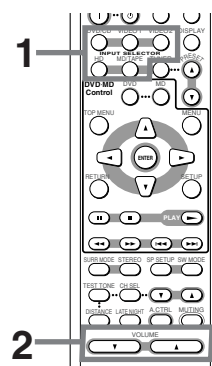
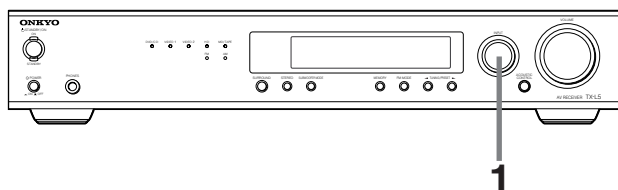

1 Remote controller

DVD/CD VIDEO1 VIDEO2
INPUT SELECTOR
HD MD/TAPE

Unit
INPUT

Press INPUT SELECTOR on the remote controller or turn the INPUT dial on the unit to select one of the following input sources:

- DVD/CD
- VIDEO 1
- VIDEO 2
- HD
- MD/TAPE

e.g. When VIDEO 1 is selected.

2 Remote controller

VOLUME
▲ ▼

Unit
VOLUME

Press VOLUME ▲/▼ on the remote controller or turn VOLUME dial to adjust the volume.

3 Start playing the selected source.

About digital sound

If the equipment is digitally connected to the AV Receiver, the sound from the digital input will automatically be selected and reproduced instead of the analog sound as explained below.

- When the DVD source is selected, the digital sound from the DVD DIGITAL INPUT (OPTICAL) connector is reproduced.
- When the VIDEO 2 source is selected, the digital sound from the VIDEO 2 DIGITAL INPUT (COAXIAL) connector is reproduced.
- When the HD source is selected, the digital sound from the HD DIGITAL INPUT (OPTICAL) connector is reproduced.

When the digital sound is reproduced, the DIGITAL, DTS, or PCM DIGITAL (2 channel digital stereo) indicator lights up according to the received sound system in the AV receiver's display.

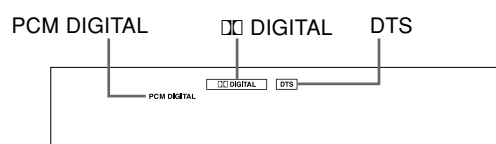

Note

The AV receiver only reproduces PCM, DOLBY DIGITAL and DTS sound formats from connected equipment.

Enjoying the picture with the sound of another source

Play the DVD, VIDEO 1 or VIDEO 2 source and select MD/TAPE, HD, FM or AM. Then you can enjoy the picture and the sound from the selected input source at the same time.

Various Functions While Playing the Connected Source

To use the following functions, see pages 28 and 29.

- Changing the Display
- Controlling the Brightness of the Lights on the AV receiver
- Muting the Sound
- Listening Through Headphones
- Using the Sleep Timer

Enjoying the Surround Modes While Playing the Connected Source

See page 30.

Operating the DVD player/CD player/MD recorder/Cassette Tape Deck With the Supplied Remote Controller

■ To operate the Onkyo DVD player/CD player

First, connect the DVD player or CD player to the AV Receiver with the **RI** cable (see page 18).

When the CD player is connected to the DVD/CD jacks, switch the source (see below).

Point the remote controller toward the AV Receiver when you want to operate this equipment.

Press DVD first.

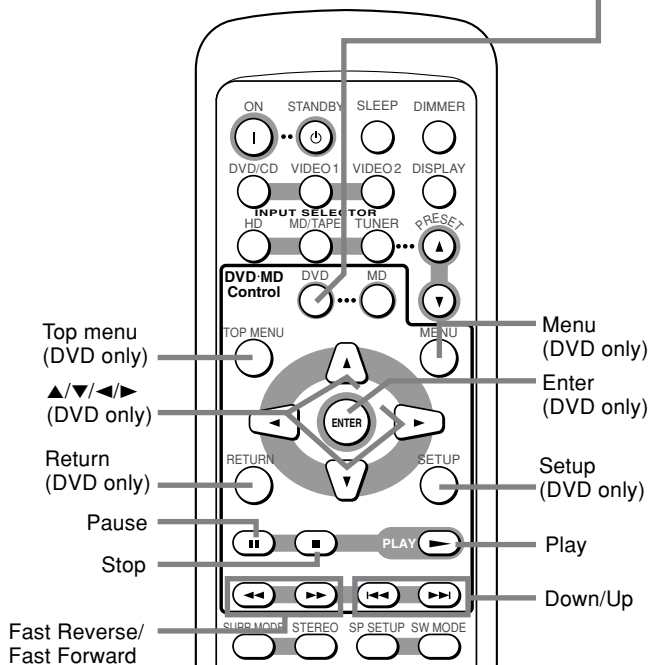

■ To operate the Onkyo MD recorder/cassette tape deck

First, connect the MD recorder or cassette tape deck to the AV Receiver with the **RI** cable (see page 18).

When the cassette tape deck is connected to the MD/TAPE jacks, switch the source (see below).

Point the remote controller toward the AV Receiver when you want to operate this equipment.

Press MD first.

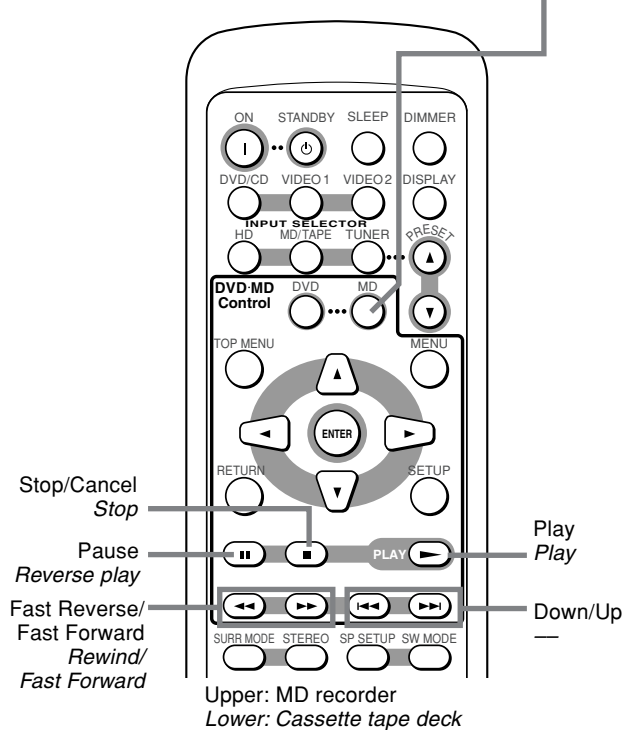

■ Switch the source from MD to TAPE/Switch the source from DVD to CD

You can set the AV receiver to show "TAPE" when the MD/TAPE source is selected by pressing MD/TAPE on the remote controller or turning the INPUT dial on the unit. In the same way, you can set the AV receiver to show "CD" when the DVD/CD source is selected.

This setting is needed to make the **RI** system control effective among the Onkyo cassette tape deck, MD recorder, DVD player and CD player.

To switch the source from MD to TAPE (or from DVD to CD)

- 1 Press MD/TAPE (or DVD/CD) to select the input source.
- 2 Press and hold MD/TAPE (or DVD/CD) on the remote controller until the display changes (for about 2 seconds).

To restore the display

Press and hold MD/TAPE (or DVD/CD) on the remote controller until the display changes (for about 2 seconds).

ex

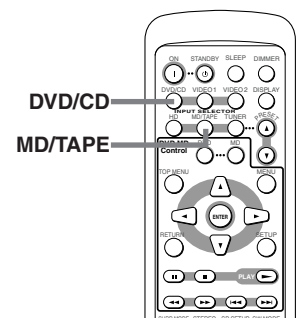
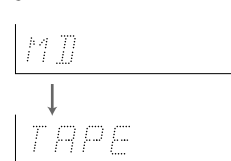

Various Functions Common to all the Sources

Changing the Display

Remote controller only
DISPLAY



Press DISPLAY.

Each time you press DISPLAY, the screen changes as follows:

When an input source other than FM or AM is selected:
Press DISPLAY once to initiate the program format display. Pressing the button again switches the display to the other display.

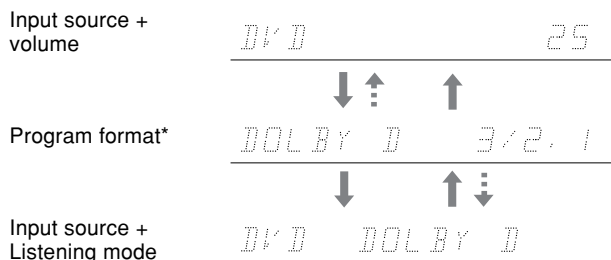

* If the input signal does not have a program format, then this will be skipped. The format display returns to the previous display after the format display has lasted for about 5 seconds (•••➔).

When FM or AM is selected as the input source:

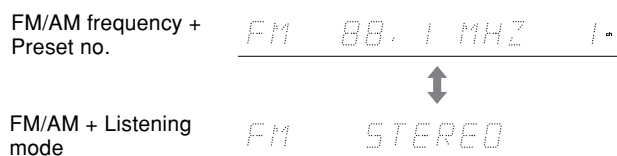

When an RDS station broadcasting PS information is settled as the input source (European models only):
Press the DISPLAY once to initiate the frequency display. Pressing the button again switches the display to the other display.

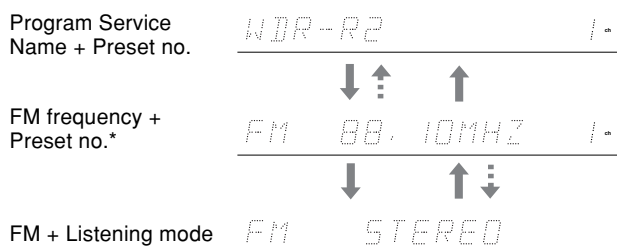

* The frequency display returns to the previous display after the frequency display has lasted for about 5 seconds (•••➔).

Controlling the Brightness of the Lights on the AV Receiver

Remote controller only
DIMMER



Press DIMMER.

Each press of the button changes the brightness as follows:

- 1. The display becomes less bright.
↓
2. The display is dimmed.
↓
3. The display is dimmed, and the indicators other than the ON indicator on the AV Receiver's front panel go off.
↓
4. The display becomes bright and the indicators on the AV receiver's front panel turn on.

Note

If you connect the Onkyo DV-L5 or MD-2000 using **RI** cable, these components also changes the brightness.

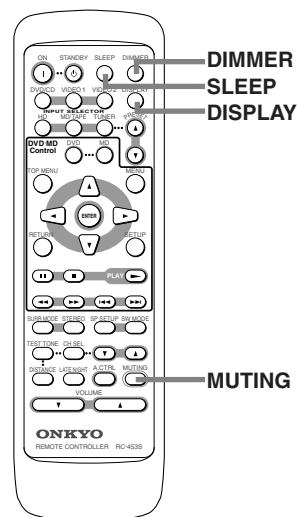
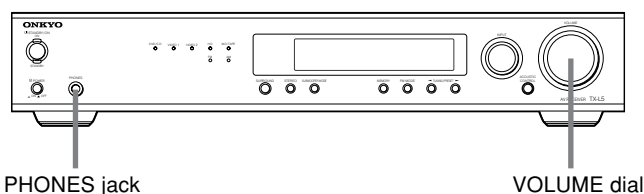

Muting the Sound

Remote controller only



Press MUTING.

The MUTING indicator flashes in the display during the muting mode.



To restore the sound, press MUTING again.

Note

If you turn off the unit during muting, and turn it on again, the sound will be restored.

Listening Through Headphones

Connect the plug of the stereo headphones to the PHONES jack on the AV Receiver.

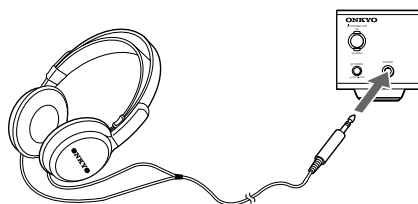

Notes

- The speakers will not reproduce sound while headphones are connected.
- The listening mode is set to "STEREO" after connecting the headphones to the PHONES jack. When you disconnect the headphones, the listening mode returns to the previous mode.

Using the Sleep Timer

Remote controller only

SLEEP



Press SLEEP.

"SLEEP 90 MIN" appears in the multipurpose display for about 5 seconds, which means the AV Receiver will turn off and enter standby mode in 90 minutes. Also the SLEEP indicator is lit in the display while the sleep timer is On.

SLEEP indicator



Each press of the button makes the remaining time shorter by 10 minutes.

■ Checking the remaining time

Press SLEEP while the Sleep Timer is On.
The remaining time is displayed.
If you press SLEEP while the remaining time is displayed, the remaining time is reduced by 10 minutes.

■ Canceling the Sleep Timer

Press SLEEP repeatedly until the SLEEP indicator goes off.

Enjoying the Surround Modes

The surround sound of the AV Receiver enables you to enjoy the presence of a movie theater or concert hall in your room.

Before using any surround mode, make sure the Speaker Setup configurations have been set (see page 20).

The speaker configuration is very important for the surround sound. See "Connecting Speakers" on page 15 and "Positioning Speakers" on page 14.

Following are the sound systems the AV Receiver can reproduce.

■ DOLBY DIGITAL Surround, DTS (Digital Theater System) Surround

This 5.1-channel digital surround format enables you to individually record and play five full-range (20 Hz-20 kHz) channels (left and right front, center, two surround channels) plus an LFE channel (Low Frequency Effect) for the low-range effect sound. It will create a realistic sound that could be heard in the theaters and concert halls.

DOLBY DIGITAL

Select this option when you play a DVD video that has a  mark.

DTS

Select this option when you play a DVD player, LD, or CD that has a  mark.

■ DOLBY PRO LOGIC II surround

This is a 5-channel surround system of a new generation, casting a bridge between the previous 4-channel (Left/Right Front, Center and monaural surround channels) Pro Logic surround and 5.1-channel Dolby Digital surround. Dolby Pro Logic II provides the MOVIE mode optimized for viewing movies and the MUSIC mode optimized for listening to music. In the MOVIE mode, the surround channel, which has been monaural and based on narrow band, is reproduced in stereo so that the feeling of movement in the played movies is more enhanced. In the MUSIC mode, the surround channel reproduces natural sound field even with 2-channel music sources.

The MOVIE mode allows you to enjoy VHS and DVD software carrying the  marking as well as some of TV broadcast programs. The MUSIC mode allows you to enjoy stereo music from CD, etc.

■ Analog/PCM (Pulse Code Modulation) surround

Analog sources include the audio records, AM/FM broadcasting and cassette tapes. The PCM (Pulse Code Modulation) signal is a kind of digital audio signal, which is recorded directly on CD or DVD without being compressed. When an analog or PCM source is played, you can enjoy unique surround modes to Onkyo as listed below.

ORCHESTRA

This mode is suitable for classical and opera music. The center channel is cut and the surround channels are emphasized to widen the stereo image. It simulates a natural reverberation as created in a large hall.

UNPLUGGED

This mode is suitable for acoustic instrumental sounds, vocals, and jazz music. By emphasizing the front stereo image, it simulates the acoustics in front of the stage.

STUDIO-MIX

This mode is suitable for rock and popular music. Lively sounds with a powerful acoustic image will make you feel as if you are in a club.

TV LOGIC

This mode offers the realistic acoustics of a TV program being aired in the TV studio. It enhances the entire surround sound and clarity of conversation.

ALL CH ST (All Channel Stereo)

This mode is useful for background music. The front and surround channels will create a stereo image.

Notes on DTS

- If you play a CD or LD that supports DTS, you may hear a noise for a short while until the DTS decoder recognizes the DTS encoded signal and starts operating. This is not a malfunction.
- If you press the pause or skip button on the player while playing a DTS source, a short noise may be heard. This is not a malfunction.
- The DTS indicator on the TX-L5 lights up while it plays the DTS source. When playback concludes and the DTS signal transmission stops, the TX-L5 remains in DTS mode and the DTS indicator remains lit. This prevents noise when you operate the pause or skip button on the player. Therefore, if the source switches from the DTS signal to the PCM signal immediately, the PCM signal may not be played. In this case, stop the playback of the source on the player for about 3 seconds, then resume playback.
- Some CD players and LD players may be unable to play DTS sources correctly even if you connect the player to the TX-L5 digitally. This is because the digital signal has been processed (such as the output level, sampling frequency, frequency response, etc.), and the TX-L5 cannot recognize the signal as DTS data. Therefore, you may hear noise when you play a DTS source while processing the signal.
- The MD/TAPE OUT, HD OUT or VIDEO 1 OUT jacks of the TX-L5 output analog audio. Do not record CDs or LDs that support DTS using these jacks. Otherwise, you will record a DTS encoded signal as noise.

Relationship between input sources and surround modes

The surround modes that can be selected are variable depending on the signal formats employed with the input sources.

Input source signal format		Analog/PCM*3	Dolby Digital*4		DTS
			2-channel source	other source	
Listening mode	source software	Cassette tape Audio CD Video CD Record FM AM HD recorder	Video DVD LD*5	Video DVD LD*5	Video DVD Audio CD LD
	STEREO*1	●	●	●	●
Surround mode	DOLBY D			●	
	DTS				●
	PL II MOVIE	●	●		
	PL II MUSIC	●	●		
Onkyo's surround mode*2	ORCHESTRA	●			
	UNPLUGGED	●			
	STUDIO-MIX	●			
	TV LOGIC	●			
	ALL CH STEREO	●			

*1 Only STEREO can be selected when SP SETUP is set to 2 ch or when headphones are used.

*2 These modes cannot be selected when SP SETUP is set to 2 ch or 3 ch.

*3 Only STEREO can be selected when the PCM source has been recorded with a sampling rate 96 kHz.

*4 Only DOLBY D (PL II if the source is a 2-channel source) or STEREO can be selected when Dolby Digital surround audio is reproduced.

*5 If you have an LD player with AC-RF output, connect it via a AC-RF demodulator to one of the TX-L5's DIGITAL INPUT terminals.

Enjoying the Surround Modes

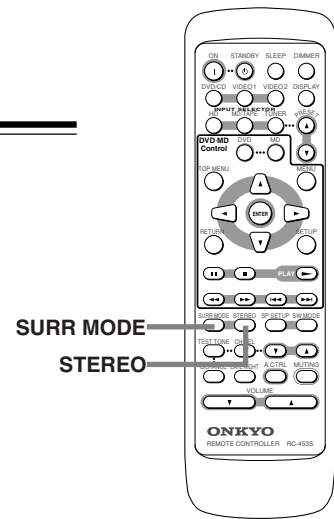
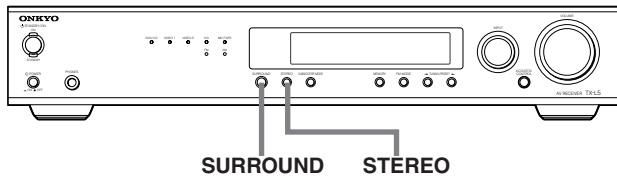

Using Dolby Pro Logic II/ Onkyo's Original DSP Modes

See "Relationship between input sources and surround modes" on page 31.

Remote controller

SURR MODE



Unit

SURROUND



Press SURR MODE on the remote controller or SURROUND on the unit to choose "PL II" or the DSP mode.

The current listening mode appears in the display when the button is pressed once, then each press of the button changes the listening mode as follows:

DSP indicator

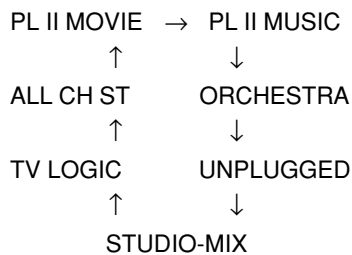
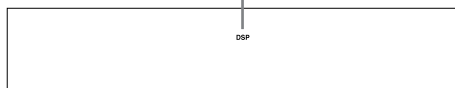

About Dolby Pro Logic II

- Suitable for Dolby Surround sources.
- In the display, "PL II MOVIE" or "PL II MUSIC" appears and the PRO LOGIC II indicator lights up.
- Skipped if "SPEAKER 2 ch" is selected on page 20.

PRO LOGIC II indicator

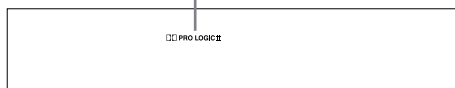

Changing the Sound to Stereo

Remote controller

STEREO



Unit

STEREO



Press STEREO.

In the display, "STEREO" appears and the STEREO indicator lights up.

STEREO indicator

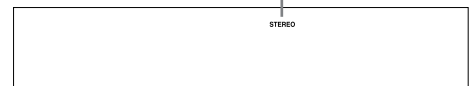

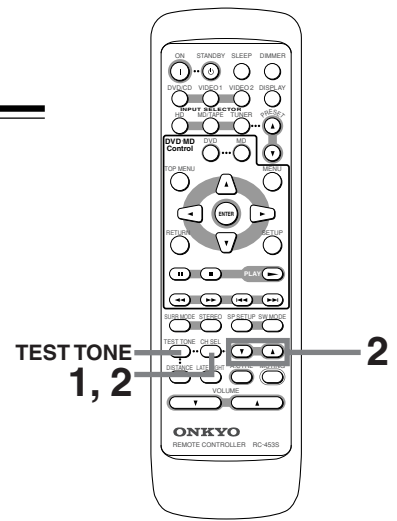

Adjusting Each Speaker's Relative Volume Balance Temporarily

You can readjust each speaker's relative volume balance according to your preference while listening to the sound. The adjusted values will return to the values set on page 22 when the AV Receiver enters standby mode, or the main power is switched off unless you save the values.

Note

You cannot adjust the volume balance while the muting function is activated.



1 (Checking each speaker's relative volume balance)

While playing the source, press CH SEL repeatedly.

Each press of the button changes the speaker which outputs the sound and the selected speaker appears in the display in the following order:

- LEFT (Front left ch.)
- ↓
- CENTER (Center ch.)
- ↓
- RIGHT (Front right ch.)
- ↓
- SURR RIGHT (Surround right ch.)
- ↓
- SURR LEFT (Surround left ch.)
- ↓
- SUBWOOFER (Subwoofer)
- ↓
- Speaker volume adjustment mode off



Note

Any speaker that is not included in the speaker configuration on page 20 is not selected even if it is actually connected.

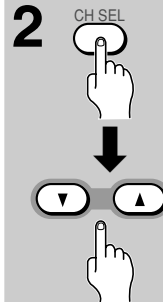

2 (Adjusting each speaker's relative volume balance)

Press CH SEL repeatedly to select the speaker, then press ▲/▼ to adjust the volume level.

The volume level can be adjusted between -12dB and +12dB.

Repeat this step to change another speaker's volume balance.

■ Saving the adjusted values



Press TEST TONE.

Enjoying the Surround Modes

Using the LATE NIGHT Function

The LATE NIGHT function operates when the sound is DOLBY DIGITAL Surround.

Cinema sound has a vast dynamic range; therefore, to hear the quieter sounds such as human conversations, they must be played back at larger volumes. When this function is set to HIGH or LOW, the dynamic range of the sound is narrowed down to allow you to easily hear minute sounds at low volumes. This function is especially useful if you wish to play a movie at low volumes during the nighttime.

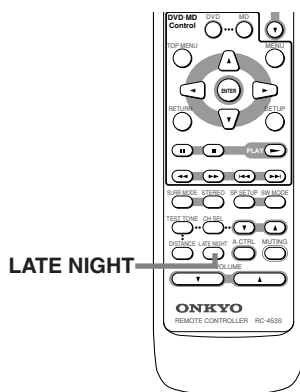

LATE NIGHT



Press LATE NIGHT.

The current setting appears in the display.

To change the setting, press the button repeatedly while the current setting is displayed.

- When the button is pressed while DOLBY DIGITAL Surround sound is being reproduced
 “LATE NIGHT = LOW”, “LATE NIGHT = HIGH” or “LATE NIGHT = OFF” can be selected.
- OFF: Turns off the Late Night function.
 LOW: Narrows the dynamic range.
 HIGH: Narrows the dynamic range more.

LATE NIGHT=LOW

Notes

- The LATE NIGHT effect is determined by each DOLBY DIGITAL sound source. Some sources may produce little or no effect.
- The LATE NIGHT function is not available when reproducing source other than Dolby Digital audio. “NOT AVAILABLE” appears in the display.
- If you turn off the unit and turn it on again, the LATE NIGHT function is set to “LATE NIGHT OFF”.

Boosting the Super Bass Sounds/High Frequency Sounds – Acoustic Control

You can enjoy more dynamic sounds by boosting the super bass/high frequency sounds, even with decreased volume.

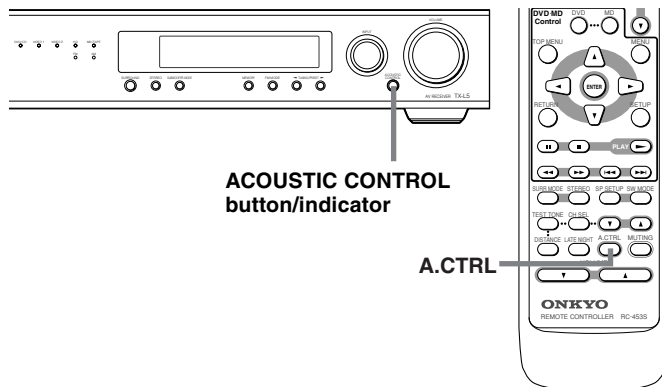

ACOUSTIC CONTROL button/indicator

A.CTRL

Remote controller

A.CTRL



Unit

ACOUSTIC CONTROL



Press A.CTRL on the remote controller or ACOUSTIC CONTROL on the unit.

Each press of the button changes the acoustic mode as follows:

→ “A.CONTROL OFF” appears in the display and the ACOUSTIC CONTROL indicator goes off.

A . CONTROL OFF

↓
 “A.CONTROL 1” appears in the display and the ACOUSTIC CONTROL indicator on the unit lights up.

The super bass sounds from the front speakers are boosted.

↓
 “A.CONTROL 2” appears in the display and the ACOUSTIC CONTROL indicator on the unit lights up.



The super bass sounds from the front speakers are further reinforced and the high frequency sounds are also reinforced.

Note

Press ACOUSTIC CONTROL on the unit or A.CTRL on the remote controller to check the setting of acoustic control while the dimmer function operates. The current setting appears in the display.

Recording a source

To record the input source signal you are currently watching or listening to

Recording of video and/or audio signals can be performed on the components connected to the VIDEO 1 OUT, HD OUT (audio only) and MD/TAPE OUT (audio only) jacks.

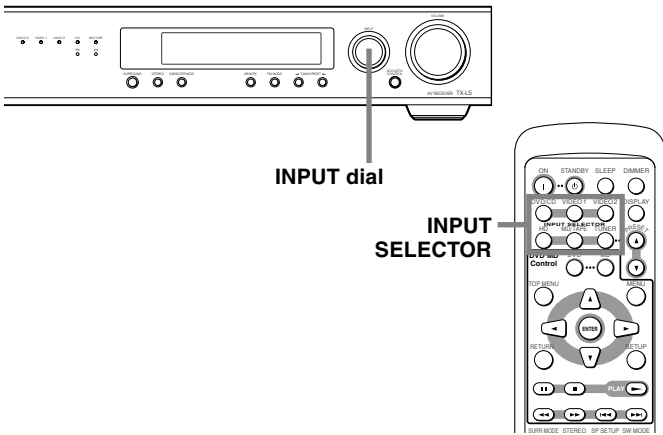

<p>1</p> <p>Remote controller</p> <p>DVD/CD VIDEO1 VIDEO2</p> <p>INPUT SELECTOR</p> <p>HD MD/TAPE</p> <p>Unit INPUT</p>	<p>Press an input selector button to select the input source to record.</p> <p>The input source is now selected and you may watch or listen to it as desired. The currently selected input source signal to the VIDEO 1 OUT, HD OUT and MD/TAPE OUT outputs for recording.</p>
<p>2</p>	<p>Start recording at the recording component as desired.</p>

Notes:

- You can record analog audio, but not digital audio. Make sure that you have made a correct analog connection.
- If you change the input source during recording, you will record the signals from the newly selected input source.
- You cannot record the surround effects.

Recording the video from one source and the audio from another

You can add the sound from one source to the video of another source to make your own video recordings. Below is an example of recording the sound from a MD player connected to MD/TAPE L/R jacks and the video from a video camera connected to VIDEO 2 IN VIDEO jack to video cassette tape in a video cassette recorder connected to the VIDEO 1 OUT L/R and VIDEO jacks.

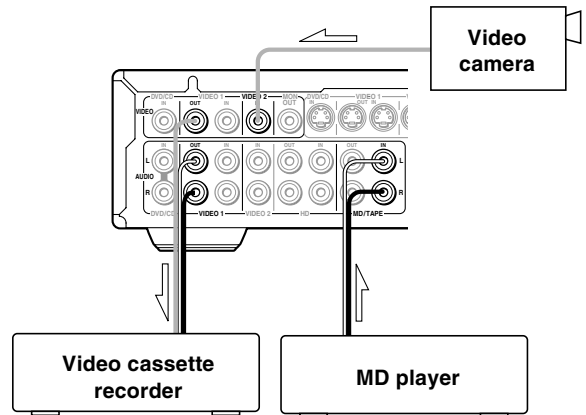

<p>1</p>	<p>Insert a MD in the MD player and insert a tape in the video camera connected to the VIDEO 2.</p>
<p>2</p>	<p>Insert a video tape for recording in the video cassette recorder connected to VIDEO 1 OUT.</p>
<p>3</p> <p>DVD/CD VIDEO1 VIDEO2</p> <p>INPUT SELECTOR</p> <p>HD MD/TAPE</p>	<p>Press VIDEO 2 on the remote controller.</p>
<p>4</p> <p>DVD/CD VIDEO1 VIDEO2</p> <p>INPUT SELECTOR</p> <p>HD MD/TAPE</p>	<p>Press MD/TAPE on the remote controller.</p> <p>This switches the audio output to MD, but the video output remains VIDEO 2 that has been selected in step 3.</p>
<p>5</p>	<p>Start recording on the video cassette recorder and start playing at the MD player and video camera as desired.</p> <p>The recorded video signal becomes the output from the video camera and recorded audio signal becomes that from the MD player.</p>

Notes

- You can record analog audio, but not digital audio. Make sure that you have made a correct analog connection.
- If you change the input source during recording, you will record the audio signals from the newly selected input source and the video signals assigned to that input source.
- You cannot record the surround effects.

Troubleshooting

Check the following guide for the possible cause of a problem before contacting service. Refer also to the respective instruction manuals of the connected components and TV.

	Symptoms	Causes	Remedies	Pages
Amplifier	The AV receiver doesn't switch on.	<ul style="list-style-type: none"> The power cord (mains lead) is disconnected. The main power is set to OFF. There is external noise interfering with the computer circuits of the AV receiver. The AC fuse is blown. 	<ul style="list-style-type: none"> Check the connection of the power cord (mains lead). Turn on the main power. Switch off the main power, then switch it on again. If not recovered, disconnect the power cord (mains lead), then connect it again. Contact your nearest Onkyo service center. 	19 19 19 –
	No sound is reproduced.	<ul style="list-style-type: none"> The muting function is activated. The AV receiver is not properly connected. Headphones are connected. 	<ul style="list-style-type: none"> Deactivate the muting function. Check the connections to the AV receiver. Decrease the volume, then disconnect the headphones. 	29 12, 13 29
	No sound or very little sound is reproduced from the center speaker.	<ul style="list-style-type: none"> The speakers are not properly connected. The listening mode is set to "STEREO" or "ORCHESTRA." The volume level of the center speaker ("CENTER") is set to minimum. A speaker configuration without the center speaker is selected. Center speaker is not connected when the speaker configuration is set 3 ch or 5 ch. 	<ul style="list-style-type: none"> Check the speaker connections. No sound is reproduced from the center speaker when the listening mode is "STEREO" or "ORCHESTRA." Adjust the volume level of the center speaker. Check that the selected speaker configuration includes the center speaker. Check the connection between the AV receiver and the speaker, or set the speaker configuration to the 2 ch or 4 ch. 	15 30 22, 33 20 20
	No picture appears on the TV screen.	<ul style="list-style-type: none"> The TV is not set to receive the output signals from the AV receiver. The video cable is not connected securely. Only the S video connection is made. 	<ul style="list-style-type: none"> Set the TV to the AV receiver's input. Check the connections between the AV receiver and TV set. Also make video connection. 	– 12 12-13
	The sound of the playback source is not heard.	<ul style="list-style-type: none"> Another input source is selected. 	<ul style="list-style-type: none"> Select the appropriate input source. 	26
	The buttons on the remote controller and AV receiver do not operate.	<ul style="list-style-type: none"> Power supply fluctuations or other abnormalities such as static electricity may interrupt correct operation. 	<ul style="list-style-type: none"> Switch off the main power, then switch it on again. If not recovered, disconnect the power cord (mains lead), then connect it again. 	–
Remote controller	The buttons on the AV receiver operate but the buttons on the remote controller do not operate.	<ul style="list-style-type: none"> A wrong DVD•MD control button is pressed. No batteries are inserted in the remote controller. The batteries are worn out. The remote controller is not pointed at the remote sensor of the AV receiver. The remote controller is too far from the AV receiver. 	<ul style="list-style-type: none"> Press the appropriate DVD•MD control button. Insert new batteries. Replace with new batteries. Point the remote controller at the remote sensor of the AV receiver. Operate the remote controller within 5 m (16 feet). 	27 7 7 7 7

	Symptoms	Causes	Remedies	Pages
Tuner	Too much noise is heard or sound is interrupted occasionally. (The FM STEREO indicator does not light steadily.)	<ul style="list-style-type: none"> • FM stereo waves may produce a hiss noise when a certain level is reached. • The position or direction of the FM antenna (aerial) is incorrect. • The station is too weak. 	<ul style="list-style-type: none"> • Switch the frequency receiving mode to mono. • Adjust the position, height, and direction of the FM antenna (aerial). • Connect an FM outdoor antenna (aerial). Try to use an antenna (aerial) with more elements. [For installation of the outdoor antenna (aerial), consult your nearest dealer as it requires special skills and experience.] 	23 16 17
	Sound is distorted or sound volume decreases.	<ul style="list-style-type: none"> • The radio wave is distorted. • Cars are running or airplanes are flying near the house. 	— —	— —
	Sound is excessively distorted.	<ul style="list-style-type: none"> • There is a tall building or a mountain nearby. [The waves transmitted from the transmission center (direct waves) and the waves reflected by buildings or mountains (diffraction waves) interfere with each other causing multi pass distortion.] 	—	—
	No preset channels are selected.	<ul style="list-style-type: none"> • The power cord (mains lead) is unplugged, or the main power is switched off, for a long time. 	<ul style="list-style-type: none"> • The preset data in memory is lost. Preset the radio stations again. 	24
Recording	Sound is reproduced from the speakers but not recorded.	<ul style="list-style-type: none"> • The sound system you are trying to record is DTS Surround. 	<ul style="list-style-type: none"> • DTS Surround sound is unable to be recorded. • Make an analog connection. 	35 35

This unit contains a sensitive microcomputer, which under certain circumstances might fail to operate due to excessive noise interference. If this happens, press the AV receiver's SUBWOOFER MODE button and \odot STANDBY/ON button at the same time until "Clear" appears in the AV receiver's display. The AV receiver turns into the standby mode, then all the custom settings in the AV receiver's memory will be erased. Please repeat the custom settings from the beginning.

Specifications

AMPLIFIER SECTION		
Power Output (FTC)	All channels 22 watts per channel min. RMS. into 6 ohms two channel driven, 1,000 Hz with no more than 0.6 % total harmonic distortion.	Output Level and Impedance
Continuous power output (DIN)	All channels 22 watts per channel min. RMS. into 6 ohms two channel driven, 1,000 Hz	REC OUT (VIDEO 1, TAPE/MD, HD) 150 mV, 2.2 kohms
Maximun power output (EIAJ)	5 × 28 watts at 6 ohms	SUB WOOFER PRE OUT 1 V, 2.2 kohms
Dynamic power output	2 × 26 watts at 6 ohms 2 × 22 watts at 8 ohms	Composite (MON OUT, VIDEO 1) 1 Vp-p, 75 ohms
Total Harmonic Distortion	0.6 % at rated power	S-VIDEO (MON OUT, VIDEO 1) Y: 1 Vp-p, 75 ohms C: 0.28 Vp-p, 75 ohms
IM Distortion	0.6 % at rated power	Frequency Response 10 to 70,000 Hz : +/- 1.5 dB
Damping Factor	40 at 8 ohms	Acoustic Control 1: +6 dB at 40 Hz 2: +10 dB at 40 Hz +7 dB at 10,000 Hz
Input Sensitivity and Impedance	DIGITAL INPUT DVD, HD (OPTICAL) 0.5 Vp-p, 75 ohms	Signal-to-noise Ratio 100 dB (IHF)
	DIGITAL INPUT VIDEO 2 (COAXIAL) 0.5 Vp-p, 75 ohms	Muting -∞ dB
	LINE (DVD/CD, VIDEO 1, 2, HD, TAPE/MD) 150 mV/50 kohms	
	Composite (DVD/CD, VIDEO 1, 2) 1 Vp-p, 75 ohms	
	S-VIDEO (DVD/CD, VIDEO 1, 2) Y: 1 Vp-p, 75 ohms C: 0.28 Vp-p, 75 ohms	
TUNER SECTION		
Tuning Range	FM: 87.50 to 108.00 MHz (50 kHz steps)	
	AM: (USA and Canadian models) 530 to 1710 kHz (10 kHz steps) (Other models) 522 to 1611 kHz (9 kHz steps)	
Usable Sensitivity	FM: Mono 11.2 dBf, 1.0 μV (75 ohms IHF) 0.9 μV (75 ohms DIN)	
	Stereo 17.2 dBf, 2.0 μV (75 ohms IHF) 23 μV (75 ohms DIN)	
	AM: 30 μV	
50 dB Quieting Sensitivity	FM: Mono 17.2 dBf, 2.0 μV (75 ohms)	
	Stereo 37.2 dBf, 20.0 μV (75 ohms)	
Capture Ratio	FM: 2.0 dB	
Image Rejection Ratio	FM: (USA and Canadian models) 40 dB (Other models) 85 dB	
	AM: 40 dB	
IF Rejection Ratio	FM: 90 dB	
	AM: 40 dB	
Signal-to-noise Ratio	FM: Mono 76 dB, IHF	
	Stereo 70 dB, IHF	
	AM: 40 dB	
Alternate Channel Att. (+/- 400 kHz)	FM: Mono 55 dB, IHF	
Selectivity	FM: 50 dB, DIN	
AM Suppression Ratio	FM: 50 dB	
Harmonic Distortion	FM: Mono 0.2 %	
	Stereo 0.3 %	
	AM: 0.7 %	
Frequency response	FM: 30 to 15,000 Hz (+/- 1.0 dB)	
Stereo Separation	FM: 45 dB at 1,000 Hz 30 dB at 100 to 10,000 Hz	
Stereo Threshold	FM: 17.2 dBf, 20 μV (75 ohms)	
GENERAL		
Power Supply Rating and Power Consumption	(USA and Canadian models) AC 120 V, 60Hz 120W (Some Asian models) AC 220-230 V, 50/60Hz 105W (Other models) AC 230-240 V, 50Hz 105W	Dimensions (W x H x D) 435 × 81 × 377 mm (17 ^{-1/8} × 3 ^{-3/16} × 14 ^{-13/16} ins.) Weight 6.1 kg (13.4 lb.)

Specifications and features are subject to change without notice.

Memo

ONKYO CORPORATION

Sales & Product Planning Div. : 2-1, Nisshin-cho, Neyagawa-shi, OSAKA 572-8540, JAPAN
Tel: 072-831-8111 Fax: 072-833-5222 <http://www.onkyo-intl.com>

ONKYO U.S.A. CORPORATION

18 Park Way, Upper Saddle River, N.J. 07458, U.S.A.
Tel: 201-785-2600 Fax: 201-785-2650 <http://www.onkyousa.com>

ONKYO EUROPE ELECTRONICS GmbH

Liegnitzerstrasse 6, 82194 Groebenzell, GERMANY
Tel: +49-8142-4401-0 Fax: +49-8142-4401-555 <http://www.onkyo.net>

ONKYO CHINA LIMITED

Units 2102-2107, Metroplaza Tower I, 223 Hing Fong Road, Kwai Chung,
N.T., HONG KONG Tel: 852-2429-3118 Fax: 852-2428-9039 <http://www.onkyochina.com>



Free Manuals Download Website

<http://myh66.com>

<http://usermanuals.us>

<http://www.somanuals.com>

<http://www.4manuals.cc>

<http://www.manual-lib.com>

<http://www.404manual.com>

<http://www.luxmanual.com>

<http://aubethermostatmanual.com>

Golf course search by state

<http://golfingnear.com>

Email search by domain

<http://emailbydomain.com>

Auto manuals search

<http://auto.somanuals.com>

TV manuals search

<http://tv.somanuals.com>