

AV Receiver

TX-SR603X

Instruction Manual

Thank you for purchasing an Onkyo AV Receiver. Please read this manual thoroughly before making any connections and plugging it in. Following the instructions in this manual will enable you to obtain optimum performance and listening enjoyment from your new AV Receiver. Please retain this manual for future reference.

Contents

Introduction.....2

Connections.....20

First Time Setup.....38

Basic Operations51

Advanced Operations.....64

Advanced Setup.....68

Zone 274

Controlling Other Components78

Specifications83

Troubleshooting.....84

WARNING:

TO REDUCE THE RISK OF FIRE OR ELECTRIC SHOCK, DO NOT EXPOSE THIS APPARATUS TO RAIN OR MOISTURE.

CAUTION:

TO REDUCE THE RISK OF ELECTRIC SHOCK, DO NOT REMOVE COVER (OR BACK). NO USER-SERVICEABLE PARTS INSIDE. REFER SERVICING TO QUALIFIED SERVICE PERSONNEL.



WARNING
RISK OF ELECTRIC SHOCK
DO NOT OPEN

AVIS
RISQUE DE CHOC ELECTRIQUE
NE PAS OUVRIR



The lightning flash with arrowhead symbol, within an equilateral triangle, is intended to alert the user to the presence of uninsulated "dangerous voltage" within the product's enclosure that may be of sufficient magnitude to constitute a risk of electric shock to persons.



The exclamation point within an equilateral triangle is intended to alert the user to the presence of important operating and maintenance (servicing) instructions in the literature accompanying the appliance.

Important Safety Instructions

1. Read these instructions.
2. Keep these instructions.
3. Heed all warnings.
4. Follow all instructions.
5. Do not use this apparatus near water.
6. Clean only with dry cloth.
7. Do not block any ventilation openings. Install in accordance with the manufacturer's instructions.
8. Do not install near any heat sources such as radiators, heat registers, stoves, or other apparatus (including amplifiers) that produce heat.
9. Do not defeat the safety purpose of the polarized or grounding-type plug. A polarized plug has two blades with one wider than the other. A grounding type plug has two blades and a third grounding prong. The wide blade or the third prong are provided for your safety. If the provided plug does not fit into your outlet, consult an electrician for replacement of the obsolete outlet.
10. Protect the power cord from being walked on or pinched particularly at plugs, convenience receptacles, and the point where they exit from the apparatus.
11. Only use attachments/accessories specified by the manufacturer.
12. Use only with the cart, stand, tripod, bracket, or table specified by the manufacturer, or sold with the apparatus. When a cart is used, use caution when moving the cart/apparatus combination to avoid injury from tip-over.

PORTABLE CART WARNING
S3125A
13. Unplug this apparatus during lightning storms or when unused for long periods of time.
14. Refer all servicing to qualified service personnel. Servicing is required when the apparatus has been damaged in any way, such as power-supply cord or plug is damaged, liquid has been spilled or objects have fallen into the apparatus, the apparatus has been exposed to rain or moisture, does not operate normally, or has been dropped.
15. Damage Requiring Service
Unplug the apparatus from the wall outlet and refer servicing to qualified service personnel under the following conditions:
 - A. When the power-supply cord or plug is damaged,
 - B. If liquid has been spilled, or objects have fallen into the apparatus,
 - C. If the apparatus has been exposed to rain or water,
 - D. If the apparatus does not operate normally by following the operating instructions. Adjust only those controls that are covered by the operating instructions as an improper adjustment of other controls may result in damage and will often require extensive work by a qualified technician to restore the apparatus to its normal operation,
 - E. If the apparatus has been dropped or damaged in any way, and
 - F. When the apparatus exhibits a distinct change in performance this indicates a need for service.
16. Object and Liquid Entry
Never push objects of any kind into the apparatus through openings as they may touch dangerous voltage points or short-out parts that could result in a fire or electric shock.
The apparatus shall not be exposed to dripping or splashing and no objects filled with liquids, such as vases shall be placed on the apparatus.
Don't put candles or other burning objects on top of this unit.
17. Batteries
Always consider the environmental issues and follow local regulations when disposing of batteries.
18. If you install the apparatus in a built-in installation, such as a bookcase or rack, ensure that there is adequate ventilation.
Leave 20 cm (8") of free space at the top and sides and 10 cm (4") at the rear. The rear edge of the shelf or board above the apparatus shall be set 10 cm (4") away from the rear panel or wall, creating a flue-like gap for warm air to escape.

Precautions

For U.S. Models

Note to CATV system installer:

This reminder is provided to call the CATV system installer's attention to Section 820-40 of the NEC which provides guidelines for proper grounding and, in particular, specifies that the cable ground shall be connected to the grounding system of the building, as close to the point of cable entry as practical.

FCC Information for User

CAUTION:

The user changes or modifications not expressly approved by the party responsible for compliance could void the user's authority to operate the equipment.

NOTE:

This equipment has been tested and found to comply with the limits for a Class B digital device, pursuant to Part 15 of the FCC Rules.

These limits are designed to provide reasonable protection against harmful interference in a residential installation. This equipment generates, uses and can radiate radio frequency energy and, if not installed and used in accordance with the instructions, may cause harmful interference to radio communications. However, there is no guarantee that interference will not occur in a particular installation.

If this equipment does cause harmful interference to radio or television reception, which can be determined by turning the equipment off and on, the user is encouraged to try to correct the interference by one or more of the following measures:

- Reorient or relocate the receiving antenna.
- Increase the separation between the equipment and receiver.
- Connect the equipment into an outlet on a circuit different from that to which the receiver is connected.
- Consult the dealer or an experienced radio/TV technician for help.

For Canadian model

NOTE: THIS CLASS B DIGITAL APPARATUS COMPLIES WITH CANADIAN ICES-003.

For models having a power cord with a polarized plug:

CAUTION: TO PREVENT ELECTRIC SHOCK, MATCH WIDE BLADE OF PLUG TO WIDE SLOT, FULLY INSERT.

Modèle pour les Canadien

REMARQUE: CET APPAREIL NUMÉRIQUE DE LA CLASSE B EST CONFORME À LA NORME NMB-003 DU CANADA.

Sur les modèles dont la fiche est polarisée:

ATTENTION: POUR ÉVITER LES CHOCS ÉLECTRIQUES, INTRODUIRE LA LAME LA PLUS LARGE DE LA FICHE DANS LA BORNE CORRESPONDANTE DE LA PRISE ET POUSSER JUSQU'AU FOND.

1. **Recording Copyright**—Unless it's for personal use only, recording copyrighted material is illegal without permission of the copyright holder.
2. **AC Fuse**— The AC fuse inside the AV receiver is not user-serviceable. If you cannot turn on the AV receiver, contact your Onkyo dealer.
3. **Care**—Occasionally you should dust the AV receiver all over with a soft cloth. For stubborn stains, use a soft cloth dampened with a weak solution of mild detergent and water. Dry the AV receiver immediately afterwards with a clean cloth. Don't use abrasive cloths, thinners, alcohol, or other chemical solvents, because they may damage the finish or remove the panel lettering.

4. Power

WARNING

BEFORE PLUGGING IN THE UNIT FOR THE FIRST TIME, READ THE FOLLOWING SECTION CAREFULLY.

AC outlet voltages vary from country to country. Make sure that the voltage in your area meets the voltage requirements printed on the AV receiver's rear panel (e.g., AC 230 V, 50 Hz or AC 120 V, 60 Hz).

Setting the [STANDBY/ON] switch to STANDBY does not fully shutdown the AV receiver. If you do not intend to use the AV receiver for an extended period, remove the power cord from the wall outlet.

For British models

Replacement and mounting of an AC plug on the power supply cord of this unit should be performed only by qualified service personnel.

IMPORTANT

The wires in the mains lead are coloured in accordance with the following code:

Blue: Neutral
Brown: Live

As the colours of the wires in the mains lead of this apparatus may not correspond with the coloured markings identifying the terminals in your plug, proceed as follows:

The wire which is coloured blue must be connected to the terminal which is marked with the letter N or coloured black.

The wire which is coloured brown must be connected to the terminal which is marked with the letter L or coloured red.

IMPORTANT

A 5 or 13 ampere fuse is fitted in this plug. Should the fuse need to be replaced, please ensure that the replacement fuse has a rating of 5 or 13 amperes and that it is approved by ASTA or BSI to BS1362. Check for the ASTA mark or the BSI mark on the body of the fuse. IF THE FITTED MOULDED PLUG IS UNSUITABLE FOR THE SOCKET OUTLET IN YOUR HOME THEN THE FUSE SHOULD BE REMOVED AND THE PLUG CUT OFF AND DISPOSED OF SAFELY. THERE IS A DANGER OF SEVERE ELECTRICAL SHOCK IF THE CUT OFF PLUG IS INSERTED INTO ANY 13 AMPERE SOCKET.

If in any doubt, consult a qualified electrician.

For European Models

Declaration of Conformity

We, ONKYO EUROPE ELECTRONICS GmbH
LIEGNITZERSTRASSE 6,
82194 GROEBENZELL,
GERMANY

CE

declare in own responsibility, that the ONKYO product described in this instruction manual is in compliance with the corresponding technical standards such as EN60065, EN55013, EN55020 and EN61000-3-2, -3-3.

GROEBENZELL, GERMANY

I. MORI

ONKYO EUROPE ELECTRONICS GmbH

This product incorporates copyright protection technology that is protected by U.S. patents and other intellectual property rights. Use of this copyright protection technology must be authorized by Macrovision Corporation, and is intended for home and other limited consumer uses only unless otherwise authorized by Macrovision. Reverse engineering or disassembly is prohibited.

U.S. Patent Nos. 4,631,603; 4,577,216; 4,819,098; 4,907,093; 5,315,448; and 6,516,132.

Supplied Accessories

Make sure you have the following accessories:

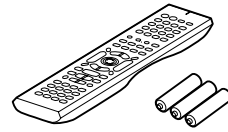

Remote controller & three batteries (AA/R6)

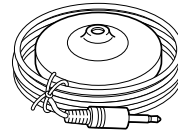

Speaker setup microphone

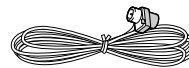

Indoor FM antenna

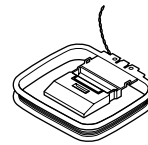

AM loop antenna

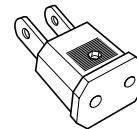

Power-plug adapter

Only supplied in certain countries. Use this adapter if your AC outlet does not match with the plug on the AV receiver's power cord (adapter varies from country to country).

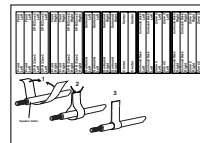

Speaker cable labels

* In catalogs and on packaging, the letter at the end of the product name indicates the color. Specifications and operations are the same regardless of color.

Features

Amplifier

- 90 watts per channel into 8 ohms, 20 Hz to 20 kHz, less than 0.08% total harmonic distortion (FTC rating)
- 7-channel amplifier
- Optimum Gain Volume Circuitry
- Zone 2 capability
- 24-bit/192 kHz D/A converters
- WRAT (Wide Range Amplifier Technology)
- Color-coded speaker terminal posts

Audio/Video

- Dolby^{*1} Digital, Dolby Digital EX, Dolby Pro Logic IIx
- DTS^{*2}, DTS-ES Discrete, DTS-ES Matrix, DTS Neo:6, and DTS 96/24
- VLSC (Vector Linear Shaping Circuitry) on the front left and right channels
- 6 digital inputs (4 optical, 2 coaxial), 1 digital optical output.
- Zone 2 line out
- Composite and S-Video to component video conversion
- Composite video to S-Video and S-Video to composite video conversion
- 3 component video inputs, 1 output
- 5 S-Video inputs, 3 outputs
- CinemaFILTER^{*3}
- Subwoofer pre out

FM/AM/XM Tuner

- 40 AM/FM presets
- AM/FM auto tuning
- XM Satellite Radio^{*4} (XM Connect-and-Play antenna accessory required; sold separately)

Others

- Includes microphone for automatic speaker setup
- Easy-to-use onscreen setup menus
- Preprogrammed remote controller for use with other AV components

*1. Manufactured under license from Dolby Laboratories. "Dolby," "Pro Logic," and the double-D symbol are trademarks of Dolby Laboratories.

*2. "DTS," "DTS 96/24," "DTS-ES," and "Neo:6" are trademarks of Digital Theater Systems, Inc.

*3. "CinemaFILTER" is a trademark of Onkyo Corporation.

*4. XM Connect & Play[™], XM Ready[®], XM Public Radio[™] are trademarks of XM Satellite Radio Inc. ©2005 XM Satellite Radio Inc. All rights reserved. All other trademarks are the property of their respective owners.



Apple and iPod are trademarks of Apple Computer, Inc., registered in the U.S. and other countries.

"Xantech" is a registered trademark of Xantech Corporation.

"Niles" is a registered trademark of Niles Audio Corporation.

Table of Contents

Basic

Introduction

Important Safety Instructions	2
Precautions	3
Supplied Accessories.....	4
Features	5
Table of Contents	6
Front & Rear Panels.....	8
Remote Controller.....	13
About Home Theater	19

Connecting the AV Receiver

About AV Connections	20
Connecting Your Speakers.....	21
Connecting Antenna.....	23
Connecting Your TV or Projector	26
Connecting AV Components	27
Connecting Audio Components	33
Connecting RI Components.....	36
Connecting the Power Cord of Another Component.....	36
Turning On the AV Receiver.....	37

First Time Setup

Automatic Speaker Setup.....	38
About the Onscreen Setup Menus	41
Initial Setup.....	42
Digital Input	42
Component Video Setup	43
Speaker Setup	44
Changing the Input Display	50

Basic Operations

Selecting the Input Source.....	51
Setting the Display Brightness	52
Muting the AV Receiver	52
Using the Sleep Timer.....	52
Using Headphones	52
Displaying Source Information	53
Using the Tuner	54
Listening to XM Satellite Radio®.....	55
Presetting AM/FM Stations & XM Channels	59
Selecting Listening Modes.....	60
Listening Mode Table	61
About the Listening Modes.....	62

Others

Specifications.....	83
Troubleshooting	84

Advanced

Controlling Other Components

Advanced Features

Entering Remote Control Codes.....	78
Learning Commands from Other Remote Controllers.....	81
Using Macros.....	82

Advanced Setup

Advanced Features

Adjusting the Bass & Treble.....	68
Audio Adjust Functions.....	68
Assigning Listening Modes to Input Sources.....	70
IntelliVolume.....	71
Setting Preferences.....	71
Digital Input Signal Formats.....	72
Changing the Remote Controller's ID.....	73

Advanced Operations

Advanced Features

Using the Late Night Function (Dolby Digital only).....	64
Using the CinemaFILTER.....	64
Adjusting Individual Speaker Levels.....	65
Using the DVD Analog Multichannel Input.....	65
Recording.....	66

Zone 2

Advanced Features

Connecting Zone 2.....	74
Setting the Powered Zone 2.....	75
Using Zone 2.....	76
Using the Remote Control in Zone 2.....	77

Front & Rear Panels

Front Panel

TX-SR603X

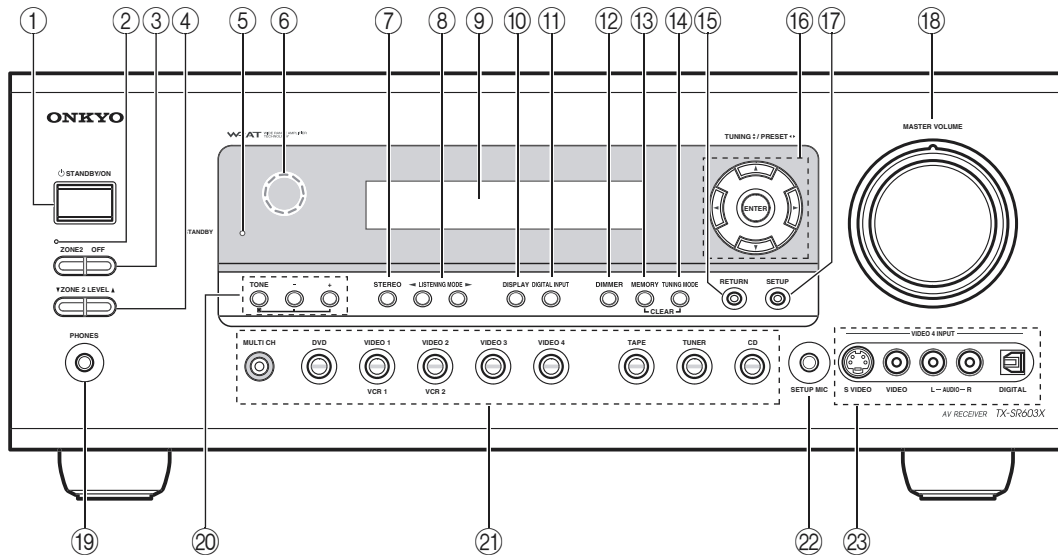

The page numbers in parentheses show where you can find the main explanation for each item.

- ① **STANDBY/ON button (37)**
This button is used to set the AV receiver to On or Standby.
- ② **ZONE 2 indicator (76)**
This indicator lights up when Zone 2 is selected.
- ③ **ZONE 2/OFF button (76)**
The ZONE 2 button is used to select the input source for Zone 2.
The OFF button is used to turn off the output of Zone 2.
- ④ **ZONE 2 LEVEL button (76)**
This button is used to set the volume for Zone 2.
- ⑤ **STANDBY indicator (37)**
This indicator lights up when the AV receiver is in Standby mode, and it flashes while a signal is being received from the remote controller.
- ⑥ **Remote-control sensor (13)**
This sensor receives control signals from the remote controller.
- ⑦ **STEREO button (60)**
This button is used to select the Stereo listening mode.
- ⑧ **LISTENING MODE [◀] [▶] buttons (60)**
These buttons are used to select the listening modes.
- ⑨ **Display**
See “Display” on page 10.
- ⑩ **DISPLAY button (53)**
This button is used to display various information about the currently selected input source.
- ⑪ **DIGITAL INPUT button (42, 72)**
This button is used to assign the digital inputs and to specify the format of digital input signals.
- ⑫ **DIMMER button (52)**
DIMMER is used to adjust the display brightness.
- ⑬ **MEMORY button (59)**
This button is used when storing or deleting radio presets.
- ⑭ **TUNING MODE button (54)**
This button is used to select the Auto or Manual tuning mode.
- ⑮ **RETURN button**
This button is used to return to the previously displayed onscreen setup menu.
- ⑯ **Arrow/TUNING/PRESET & ENTER buttons**
When the AM or FM input source is selected, the TUNING [▲] [▼] buttons are used to tune the tuner, and the PRESET [◀] [▶] buttons are used to select radio presets (see page 59). When the onscreen setup menus are used, they work as arrow buttons and are used to select and set items. The ENTER button is also used with the onscreen setup menus.

- ⑰ **SETUP button**
This button is used to access the onscreen setup menus that appear on the connected TV.
- ⑱ **MASTER VOLUME control (51)**
This control is used to adjust the volume of the AV receiver to MIN, 1 through 99, or MAX.
- ⑲ **PHONES jack (52)**
This 1/4-inch phone jack is for connecting a standard pair of stereo headphones for private listening.
- ⑳ **TONE, [-] & [+] buttons (68)**
These buttons are used to adjust the bass and treble.
- ㉑ **Input selector buttons (51)**
These buttons are used to select from the following input sources: MULTI CH, DVD, VIDEO 1, VIDEO 2, VIDEO 3, VIDEO 4, TAPE, TUNER or CD.
The [MULTI CH] button selects the DVD analog multichannel input.
- ㉒ **SETUP MIC (38)**
The included speaker setup microphone is connected here for automatic speaker setup.
- ㉓ **VIDEO 4 INPUT**
This input can be used to connect a camcorder, game console, and so on. There are jacks for optical digital audio, S-Video, composite video, and analog audio.

Display

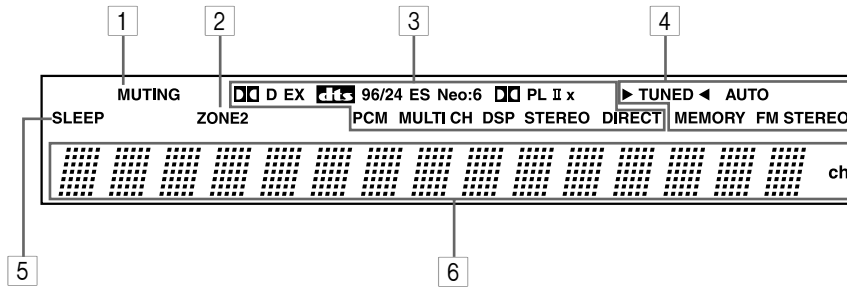

The page numbers in parentheses show where you can find the main explanation for each item.

- 1 **MUTING indicator (52)**
This indicator flashes while the AV receiver is muted.
- 2 **ZONE 2 indicator (76)**
This indicator lights up when Zone 2 is selected.
- 3 **Listening mode & format indicators**
These indicators show the currently selected listening mode and the format of digital input signals.
- 4 **Tuning indicators (54)**
TUNED: This indicator lights up when the AV receiver is tuned into a radio station.
AUTO: This indicator lights up when the Auto Tuning mode is selected, and disappears when the Manual Tuning mode is selected.
- 5 **SLEEP indicator (52)**
This indicator lights up when the Sleep function has been set.
- 6 **Message area**
This area of the display shows various information about the currently selected source.
- MEMORY:** This indicator lights up when presetting radio stations.
- FM STEREO:** This indicator lights up when the AV receiver is tuned to a stereo FM station.

Rear Panel

TX-SR603X

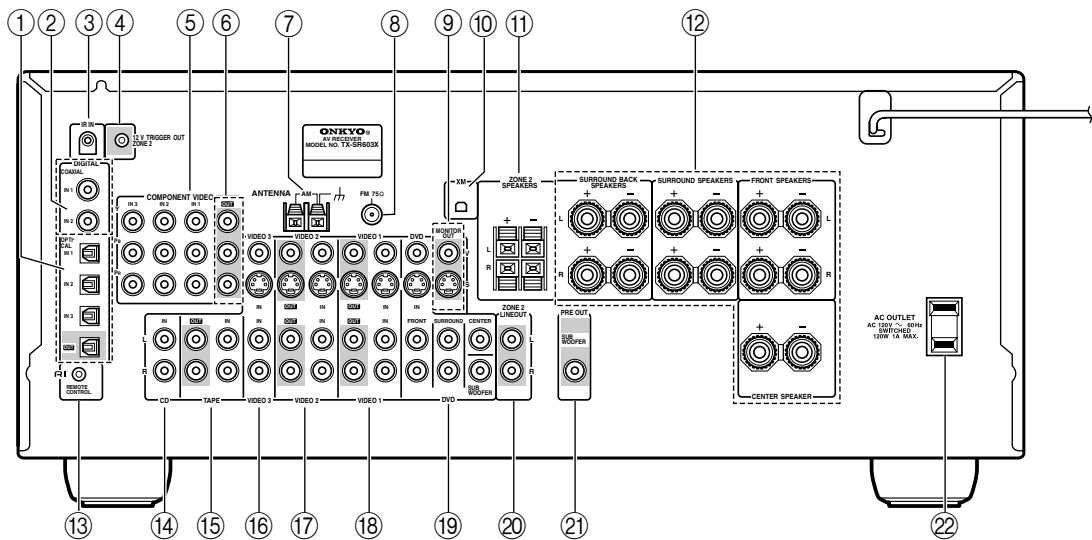

The page numbers in parentheses show where you can find the main explanation for each item.

① **OPTICAL DIGITAL**

The optical digital audio inputs can be used to connect CD and DVD players, and other components with an optical digital audio output.

The optical output can be used connect a CD recorder or other digital recorder with an optical digital input.

② **COAXIAL DIGITAL**

The coaxial digital audio inputs can be used to connect CD and DVD players, and other components with a coaxial digital audio output.

③ **IR IN (77)**

If you want to use the remote controller to control the AV receiver from Zone 2, or if the AV receiver is installed in a cabinet and the line of sight between the AV receiver and the remote controller is obstructed, a commercially available IR receiver can be connected here.

④ **12V TRIGGER OUT ZONE 2 (77)**

This output can be connected to the 12-volt trigger input on a power amplifier in Zone 2. When Zone 2 is turned on, a 12-volt trigger signal is output.

⑤ **COMPONENT VIDEO IN 1, 2, 3**

These component video inputs can be used to connect AV components with component video outputs, such as DVD players.

⑥ **COMPONENT VIDEO OUT**

This component video output can be used to connect a TV or projector with a component video input.

⑦ **AM ANTENNA (23)**

These push terminals are for connecting an AM antenna.

⑧ **FM ANTENNA (23)**

This jack is for connecting an FM antenna.

⑨ **MONITOR OUT**

The S-Video or composite video jack should be connected to a video input on your TV or projector.

⑩ **XM ANTENNA**

This jack is for connecting an XM antenna, sold separately (see page 55).

⑪ **ZONE 2 SPEAKERS (74)**

These terminals are for connecting speakers in Zone 2.

⑫ **FRONT, CENTER, SURROUND & SURROUND BACK SPEAKERS (22)**

These terminal posts are for connecting your front, center, surround, and surround back speakers.

See pages 26-36 for connection information.

⑬ **RI REMOTE CONTROL**

This **RI** (Remote Interactive) jack can be connected to an **RI** jack on another Onkyo AV component. The AV receiver's remote controller can then be used to control that component. To use **RI**, you must make an analog audio connection (RCA) between the AV receiver and the other AV component, even if they are connected digitally.

⑭ **CD IN**

This analog audio input is for connecting a CD player's analog audio output.

⑮ **TAPE IN/OUT**

This analog audio input and output are for connecting a recorder with an analog audio input and output (cassette, Mini Disc, etc.).

⑯ **VIDEO 3 IN**

Here you can connect a video source (VCR, set-top box, etc.). Input jacks include S-Video, composite video, and analog audio.

⑰ **VIDEO 2 IN/OUT**

Here you can connect a VCR. Input and output jacks include S-Video, composite video, and analog audio.

⑱ **VIDEO 1 IN/OUT**

Here you can connect a VCR. Input and output jacks include S-Video, composite video, and analog audio.

⑲ **DVD IN**

Here you can connect a DVD player. Input jacks include S-Video, composite video, and analog audio. You can connect a DVD player's 2-channel analog audio output or 5.1-channel analog audio output.

⑳ **ZONE 2 LINE OUT (74)**

This analog audio output can be connected to a line input on an integrated amplifier in Zone 2.

㉑ **PRE OUT (21)**

The SUBWOOFER jack is for connecting a powered subwoofer.

㉒ **AC OUTLET**

This switched AC outlet can be used to supply power to other AV components. The type of outlet depends on the country in which you purchased your AV receiver.

See pages 26-36 for connection information.

Remote Controller

Installing the Batteries

- 1** To open the battery compartment, press the small hollow and slide off the cover.

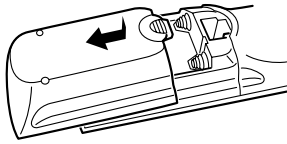

- 2** Insert the three supplied batteries (AA/R6) in accordance with the polarity diagram inside the battery compartment.

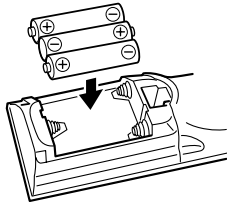

- 3** Put the cover onto the remote controller and slide it shut.

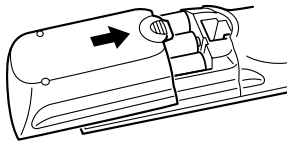

Notes:

- If the remote controller doesn't work reliably, try replacing the batteries.
- Don't mix new and old batteries or different types of batteries.
- If you intend not to use the remote controller for a long time, remove the batteries to prevent damage from leakage or corrosion.
- Expired batteries should be removed as soon as possible to prevent damage from leakage or corrosion.

Using the Remote Controller

To use the remote controller, point it at the AV receiver's remote control sensor, as shown below.

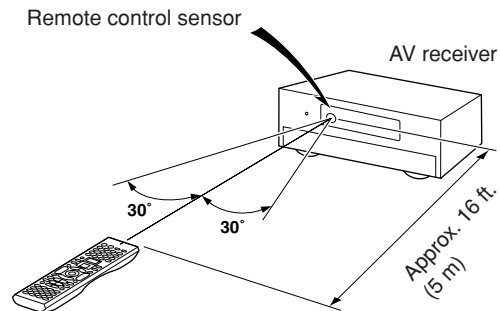

Notes:

- The remote controller may not work reliably if the AV receiver is subjected to bright light, such as direct sunlight or inverter-type fluorescent lights. Keep this in mind when installing.
- If another remote controller of the same type is used in the same room, or the AV receiver is installed close to equipment that uses infrared rays, the remote controller may not work reliably.
- Don't put anything, such as a book, on the remote controller, because the buttons may be pressed inadvertently, thereby draining the batteries.
- The remote controller may not work reliably if the AV receiver is installed in a rack behind colored glass doors. Keep this in mind when installing.
- The remote controller will not work if there's an obstacle between it and the AV receiver's remote control sensor.

About the Remote Controller Modes

Including the AV receiver, the remote controller can be used to control up to nine different components. The remote controller has a specific operating mode for use with each type of component. Modes are selected by using the eight REMOTE MODE buttons.

RECEIVER/TAPE Mode

In RECEIVER/TAPE mode, you can control the AV receiver and an Onkyo cassette recorder connected via **RI**.

DVD Mode

By default, you can control an Onkyo DVD player in this mode. By entering the appropriate remote control code, you can control components made by other manufacturers (see page 78).

CD Mode

By default, you can control an Onkyo CD player in this mode. By entering the appropriate remote control code, you can control a CD player, MD player, or CD recorder made by another manufacturer (see page 78).

HDD Mode

This mode is for controlling Onkyo's next generation HDD-compatible components via **RI**.

TV & VCR Modes

With these modes, you can control a TV and VCR. You must enter the appropriate remote control code first (see page 78).

CABLE/CDR & SAT/MD Modes

In CABLE/CDR mode, you can control an Onkyo CD recorder, or a cable TV receiver. In SAT/MD mode, you can control an Onkyo MD recorder, or a satellite TV receiver. You must enter the appropriate remote control code first (see page 78).

1 Use the **REMOTE MODE** buttons to select a mode.

2 Use the buttons supported by that mode to control the component.

RECEIVER/TAPE mode: see page 14

DVD mode: see page 16

CD/MD/CDR modes: see page 17

HDD mode: see page 18

TV/VCR/SAT/CABLE modes: see page 80

RECEIVER/TAPE Mode

RECEIVER/TAPE mode is used to control the AV receiver. It can also be used to control an Onkyo cassette recorder connected via **RI**.

To set the remote controller to RECEIVER/TAPE mode, press the **[RECEIVER]** REMOTE MODE button.

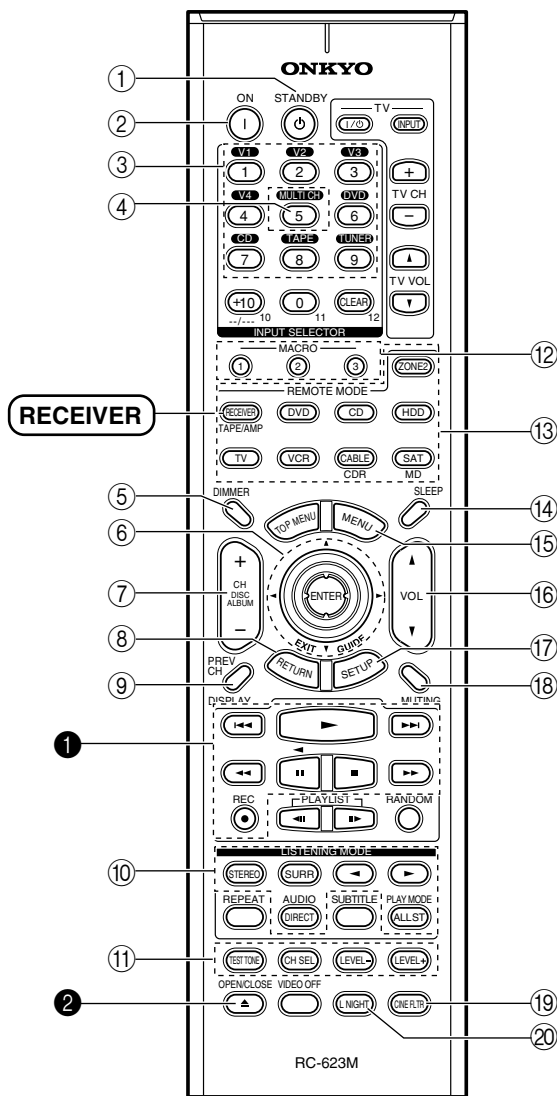

Note:

Some of the remote controller operations described in this manual may not work as expected with other components.

For detailed information, see the pages in parentheses.

- ① **STANDBY button (37)**
This button is used to set the AV receiver to Standby.
- ② **ON button (37)**
This button is used to turn on the AV receiver.
- ③ **INPUT SELECTOR buttons (51)**
These buttons are used to select the input sources.
- ④ **MULTI CH button (65)**
This button is used to select the multichannel DVD input.
- ⑤ **DIMMER button (52)**
This button is used to adjust the display brightness.
- ⑥ **Arrow [▲]/[▼]/[◀]/[▶] & ENTER buttons**
These buttons are used to select and adjust settings.
- ⑦ **CH +/- button (59)**
This button is used to select radio presets.
- ⑧ **RETURN button**
This button is used to return to the previous display when changing settings.
- ⑨ **DISPLAY button (53, 54)**
This button is used to display various information about the currently selected input source.
- ⑩ **LISTENING MODE buttons (60)**
These buttons are used to select the listening modes. The [STEREO], [SURR], and LISTENING MODE [◀]/[▶] buttons can be used regardless of the currently selected remote controller mode.
STEREO button
This button selects the Stereo listening mode.
SURR button
This button selects the Dolby and DTS listening modes.
LISTENING MODE [◀]/[▶] buttons
These buttons are used to select the listening modes.
DIRECT button
This button selects the Direct listening mode.
ALL ST button
This button selects the All Channel Stereo listening mode.
- ⑪ **TEST TONE, CH SEL, LEVEL- & LEVEL+ buttons (48)**
These buttons are used to adjust the level of each speaker.
- ⑫ **MACRO buttons (82)**
These buttons are used with the Macro function.
- ⑬ **REMOTE MODE buttons (14)**
These buttons are used to select the remote controller modes. When you press a button on the remote controller, the REMOTE MODE button for the currently selected mode lights up.

- ⑭ **SLEEP button (52)**
This button is used to set the Sleep function.
- ⑮ **MENU button (56)**
This button is used to select the search mode for XM Satellite Radio.
- ⑯ **VOL [▲]/[▼] button (51)**
This button can be used to adjust the volume of the AV receiver regardless of the currently selected remote controller mode.
- ⑰ **SETUP button**
This button is used to access various settings.
- ⑱ **MUTING button (52)**
This button is used to mute the AV receiver.
- ⑲ **CINE FLTR button (64)**
This button is used to set the CinemaFILTER function.
- ⑳ **L NIGHT button (64)**
This button is used to set the Late Night function.

■ TAPE mode

For twin cassette decks, only Deck B can be controlled.

- ① **Previous & Next [◀◀]/[▶▶] buttons**
The Previous [◀◀] button is used to select the previous track. During playback it selects the beginning of the current track. The Next [▶▶] button is used to select the next track.
Depending on how it was recorded, the Previous and Next [◀◀]/[▶▶] buttons may not work properly with some cassette tapes.
Play [▶] button
This button is used to start playback.
Rewind & FF [◀◀]/[▶▶] buttons
The Rewind [◀◀] button is used to start rewind. The FF [▶▶] button is used to start fast forward.
Reverse Play [◀] button
This button is used to start reverse playback.
Stop [■] button
This button is used to stop playback.
REC [●] button
This button is used to start recording.
- ② **Eject [▲] button**
This button is used to eject the cassette tape.

DVD Mode

To set the remote controller to DVD mode, press the [DVD] REMOTE MODE button.

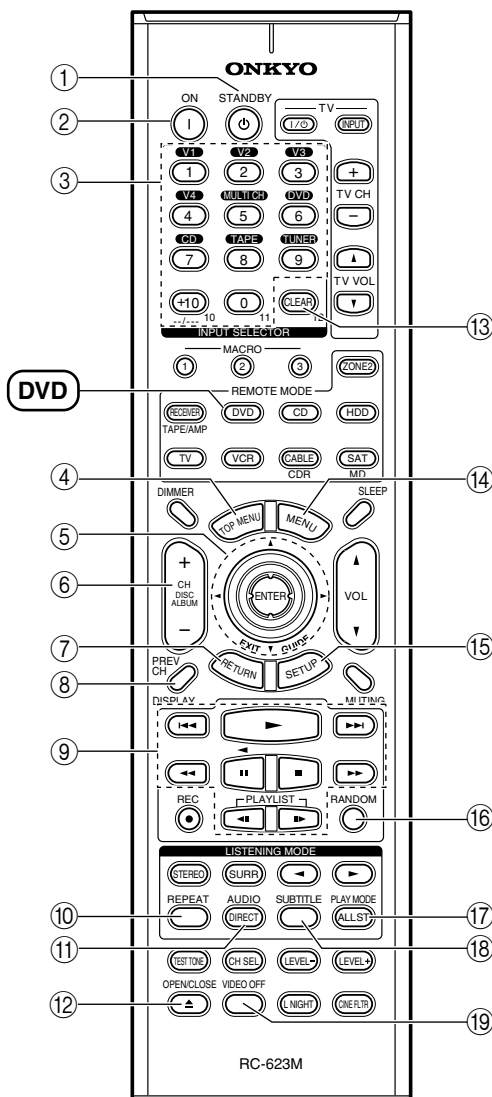

- ① **STANDBY button**
This button sets the DVD player to Standby.
- ② **ON button**
This button is used to turn on the DVD player.
- ③ **Number buttons**
These buttons are used to enter title, chapter, and track numbers and to enter times for locating specific points in time.

- ④ **TOP MENU button**
This button is used to select a DVD's top menu.
- ⑤ **Arrow [▲]/[▼]/[◀]/[▶] & ENTER buttons**
These buttons are used to navigate DVD menus and the DVD player's onscreen setup menus.
- ⑥ **DISC +/- button**
This button selects discs on a DVD changer.
- ⑦ **RETURN button**
This button is used to exit the DVD player's onscreen setup menu and to restart menu playback.
- ⑧ **DISPLAY button**
This button is used to display information about the current disc, title, chapter, or track on the DVD player's display, including the elapsed time, remaining time, total time, and so on.
- ⑨ **Playback buttons**
From left to right: Previous, Play, Next, Fast Reverse, Pause, Stop, Fast Forward, Slow Reverse, and Slow Forward.
- ⑩ **REPEAT button**
This button is used to set the repeat playback functions.
- ⑪ **AUDIO button**
This button selects foreign language soundtracks and audio formats (e.g., Dolby Digital or DTS).
- ⑫ **OPEN/CLOSE [▲] button**
This button is used to open and close the disc tray.
- ⑬ **CLEAR button**
This button is used to cancel functions and to clear entered numbers.
- ⑭ **MENU button**
This button is used to display a DVD's menu.
- ⑮ **SETUP button**
This button is used to access the DVD player's onscreen setup menus.
- ⑯ **RANDOM button**
This button is used with the random playback function.
- ⑰ **PLAY MODE button**
This button is used to select play modes on a component with selectable play modes.
- ⑱ **SUBTITLE button**
This button is used to select subtitles.

- ⑱ **VIDEO OFF button**
This button is used to turn off the internal video circuitry, eliminating any possibility of interference.

CD, MD & CDR Modes

To control an Onkyo CD player, or a CD/MD recorder made by another manufacturer, press the [CD] REMOTE MODE button to select the CD remote controller mode.

To control an Onkyo MD recorder or CD recorder, press the [MD] or [CDR] REMOTE MODE button to select the MD or CDR remote controller mode.

To control an Onkyo MD recorder or CD recorder, or a component made by another manufacturer, you must first enter the appropriate remote control code (see page 78).

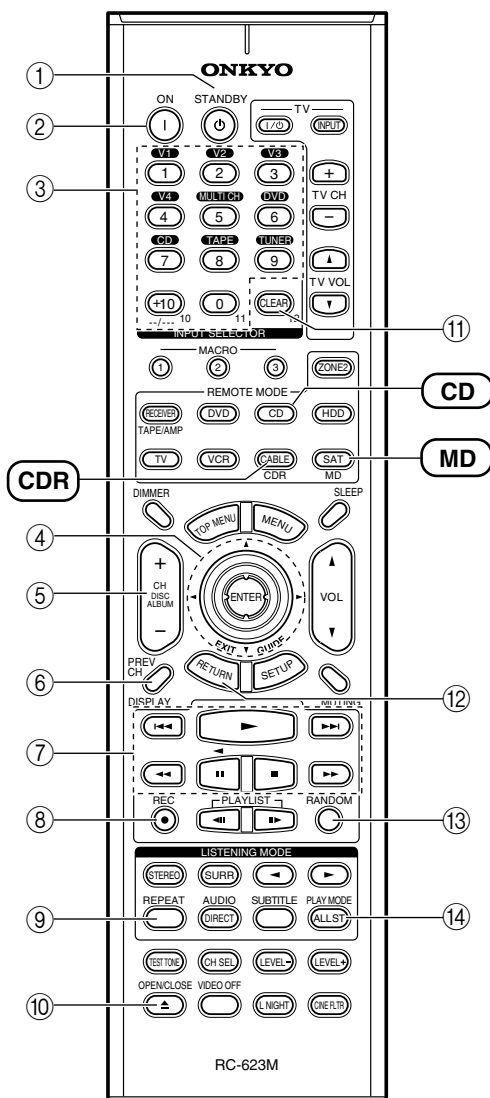

- ① **STANDBY button**
This button sets the CD player or MD/CD recorder to Standby.
- ② **ON button**
This button is used to set the CD player or MD/CD recorder to On or Standby.
- ③ **Number buttons**
These buttons are used to enter track numbers and to enter times for locating specific points in time.
- ④ **Arrow [▲]/[▼]/[◀]/[▶] & ENTER buttons**
These buttons can be used with some components.
- ⑤ **DISC +/- button**
This button selects discs on a CD changer.
- ⑥ **DISPLAY button**
This button is used to display information about the current disc or track on the CD player or MD/CD recorder's display, including the elapsed time, remaining time, total time, and so on.
- ⑦ **Playback buttons**
From left to right: Previous, Play, Next, Fast Reverse, Pause, Stop, and Fast Forward.
- ⑧ **REC [●] button**
This button is used to start recording on an MD or CD recorder.
- ⑨ **REPEAT button**
This button is used to set the repeat playback functions.
- ⑩ **OPEN/CLOSE [▲] button**
This button is used to open and close the disc tray, or eject the MiniDisc.
- ⑪ **CLEAR button**
This button is used to cancel functions and to clear entered numbers.
- ⑫ **RETURN button**
This button can be used with some components.
- ⑬ **RANDOM button**
This button is used with the random playback function.
- ⑭ **PLAY MODE button**
This button is used to select play modes on a component with selectable play modes.

HDD Mode

HDD mode is for controlling Onkyo's next generation HDD-compatible components. As of 2005, it can be used with the Onkyo DS-A1 Remote Interactive Dock and Apple iPod connected via **RI**.

When Using the DS-A1:

- Connect the DS-A1 to the TAPE IN or VIDEO 3 IN jacks.
- Set the DS-A1's RI MODE switch to HDD.
- Set the AV receiver's input display to HDD (see page 50).
- Refer to the DS-A1's instruction manual.

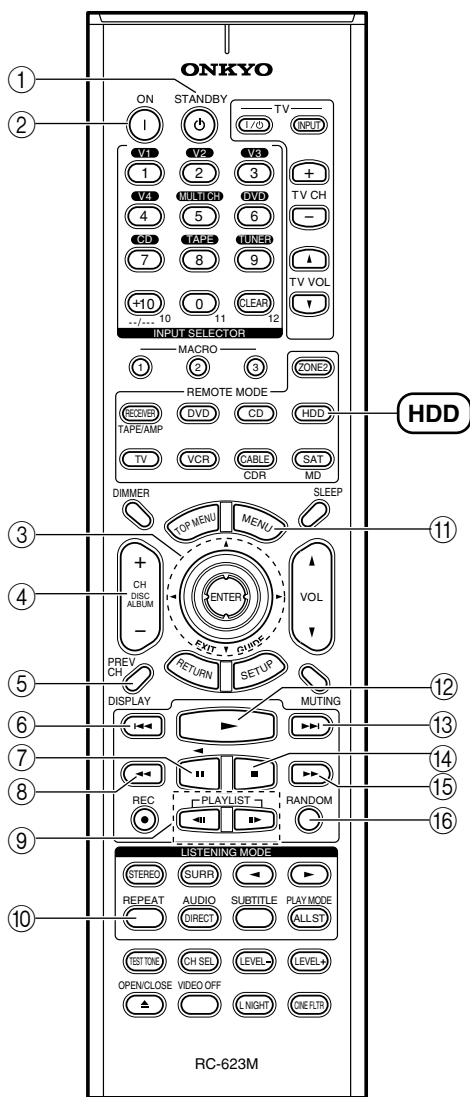

1 STANDBY button

This button turns off the HDD-compatible component.

2 ON button*

This button turns on the HDD-compatible component.

3 Arrow [▲]/[▼] and ENTER buttons*

These buttons are used to navigate menus on the HDD-compatible component.

4 ALBUM +/- button*

This button selects the next or previous album on the HDD-compatible component.

5 DISPLAY button*

This button turns on the backlight for 30 seconds on the HDD-compatible component.

6 Previous [◀◀] button

This button restarts the current song on the HDD-compatible component. Press it twice to select the previous song.

7 Pause [||] button

This button pauses playback on the HDD-compatible component. (With 3rd generation iPods, it works as a Play/Pause button.)

8 Rewind [◀◀] button

Press and hold to rewind the HDD-compatible component.

9 PLAYLIST [◀◀]/[▶▶] buttons*

These buttons select the previous or next playlist on the HDD-compatible component.

10 REPEAT button*

This button sets the Repeat function to One, All, or Off on the HDD-compatible component.

11 MENU button*

This button is used to navigate menus on the HDD-compatible component.

12 Play [▶] button

This button starts playback on the HDD-compatible component. If the component is off, it will turn on automatically. (With 3rd generation iPods, this button works as a Play/Pause button.)

13 Next [▶▶] button

This button selects the next song on the HDD-compatible component.

14 Stop [■] button

This button stops playback and displays the menu on the HDD-compatible component.

15 Fast Forward [▶▶] button

Press and hold to fast forward the HDD-compatible component.

16 RANDOM button*

This button sets the Shuffle function to Songs, Albums, or Off on the HDD-compatible component.

* Buttons marked with an asterisk (*) are not supported by 3rd generation iPods.

About Home Theater

Enjoying Home Theater

Thanks to the AV receiver's superb capabilities, you can enjoy surround sound with a real sense of movement in your own home—just like being in a movie theater or concert hall. With DVDs you can enjoy DTS and Dolby Digital. With analog and digital TV you can enjoy Dolby Pro Logic IIx or Onkyo's own DSP surround listening modes.

Front left and right speakers

These output the overall sound. Their role in a home theater is to provide a solid anchor for the sound image. They should be positioned facing the listener at about ear level, and equidistant from the TV. Angle them inward so as to create a triangle, with the listener at the apex.

Center speaker

This speaker enhances the front left and right speakers, making sound movements distinct and providing a full sound image. In movies it's used mainly for dialog.

Position it close to your TV (preferably on top) facing forward at about ear level, or at the same height as the front left and right speakers.

Subwoofer

The subwoofer handles the bass sounds of the LFE (Low-Frequency Effects) channel. The volume and quality of the bass output from your subwoofer will depend on its position, the shape of your listening room, and your listening position. In general, a good bass sound can be obtained by installing the subwoofer in a front corner, or at one-third the width of the wall, as shown.

Tip: To find the best position for your subwoofer, while playing a movie or some music with good bass, experiment by placing your subwoofer at various positions within the room, and choose the one that provides the most satisfying results.

Surround left and right speakers

These speakers are used for precise sound positioning and to add realistic ambience.

Position them at the sides of the listener, or slightly behind, about 2–3 feet (60–100 cm) above ear level. Ideally they should be equidistant from the listener.

Surround back left and right speakers

These speakers are necessary to enjoy Dolby Digital EX, DTS-ES Matrix, and DTS-ES Discrete. They enhance the realism of surround sound and improve sound localization behind the listener. Position them behind the listener about 2–3 feet (60–100 cm) above ear level.

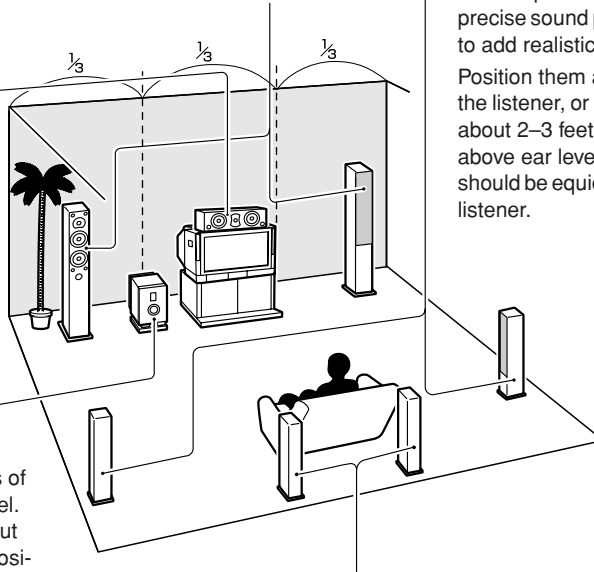

Connecting the AV Receiver

About AV Connections

- Before making any AV connections, read the manuals supplied with your other AV components.
- Don't connect the power cord until you've completed and double-checked all AV connections.

Optical Digital Jacks

The AV receiver's optical digital jacks have shutter-type covers that open when an optical plug is inserted and close when it's removed. Push plugs in all the way.

Caution: To prevent shutter damage, hold the optical plug straight when inserting and removing.

AV Connection Color Coding

RCA-type AV connections are usually color-coded: red, white, and yellow. Use red plugs to connect right-channel audio inputs and outputs (typically labeled "R"). Use white plugs to connect left-channel audio inputs and outputs (typically labeled "L"). And use yellow plugs to connect composite video inputs and outputs.



- Push plugs in all the way to make good connections (loose connections can cause noise or malfunctions).
- To prevent interference, keep audio and video cables away from power cords and speaker cables.

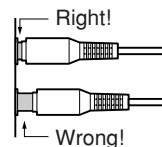

AV Cables & Jacks

Video

Cable	Jack	Description
	Y Pr Pb	Component video separates the luminance (Y) and color difference signals (Pr, Pb), providing the best picture quality (some TV manufacturers label their component video sockets slightly differently).
	S	S-Video separates the luminance and color signals and provides better picture quality than composite video.
	V	Composite video is commonly used on TVs, VCRs, and other video equipment. Use only dedicated composite video cables.

Audio

Cable	Jack	Description
	OPTICAL 	Offers the best sound quality and allows you to enjoy surround sound (e.g., Dolby Digital, DTS). The audio quality is the same as for coaxial.
	COAXIAL 	Offers the best sound quality and allows you to enjoy surround sound (e.g., Dolby Digital, DTS). The audio quality is the same as for optical.
	L R 	This cable carries analog audio. It's the most common connection format for analog audio, and can be found on virtually all AV components.
	FRONT SURR CENTER DVD SUB WOOFER 	This cable carries multichannel analog audio and it's typically used to connect DVD players with a 5.1-channel analog audio output. Several standard analog audio cables can be used instead of a multi-channel cable.

Note: The AV receiver does not support SCART plugs.

Connecting Your Speakers

Speaker Configuration

For the best surround sound experience, you should connect seven speakers and a powered subwoofer.

The following table indicates the channels you should use depending on the number of speakers that you have.

Number of speakers:	2	3	4	5	6	7
Front left	✓	✓	✓	✓	✓	✓
Front right	✓	✓	✓	✓	✓	✓
Center		✓		✓	✓	✓
Surround left			✓	✓	✓	✓
Surround right			✓	✓	✓	✓
Surround back					✓	
Surround back left*						✓
Surround back right*						✓

*If you're using only one surround back speaker, connect it to the left (L) SURROUND BACK SPEAKERS terminals.

No matter how many speakers you use, a powered subwoofer is recommended for a really powerful and solid bass.

To get the best from your surround sound system, you need to set the speaker settings by using the supplied setup microphone (see page 38).

Using Dipole Speakers

You can use dipole speakers for the surround left and right and surround back left and right speakers. Dipole speakers output the same sound in two directions.

Dipole speakers typically have an arrow printed on them to indicate how they should be positioned. The surround left and right dipole speakers should be positioned so that their arrows point toward the TV/screen, while the surround back left and right dipole speakers should be positioned so that their arrows point toward each other, as shown.

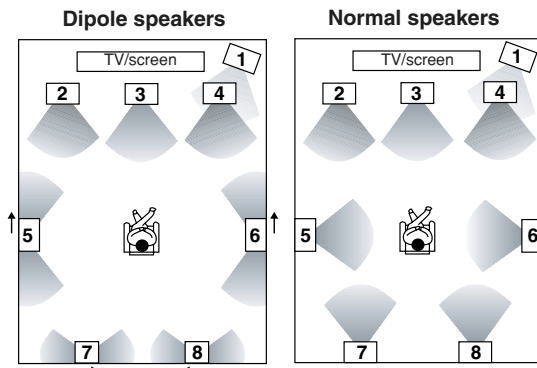

1. Subwoofer
2. Front left speaker
3. Center speaker
4. Front right speaker
5. Surround left speaker

6. Surround right speaker
7. Surround back left speaker
8. Surround back right speaker

Connecting a Powered Subwoofer

Using a suitable cable, connect the AV receiver's SUBWOOFER PRE OUT to an input on your powered subwoofer, as shown. If your subwoofer is unpowered and you're using an external amplifier, connect the SUBWOOFER PRE OUT to an input on the amp.

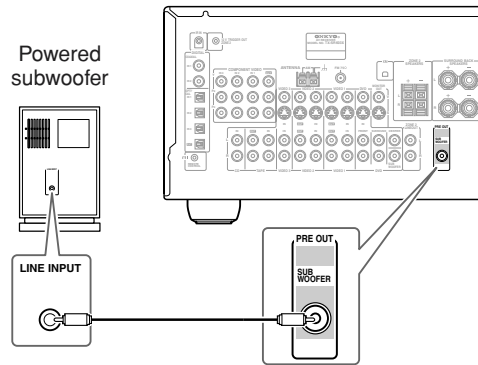

Attaching the Speaker Labels

The AV receiver's positive (+) speaker terminals are color-coded for ease of identification (the negative (-) speaker terminals are all black).

Speaker terminal	Color
Front left, Zone 2 left	White
Front right, Zone 2 right	Red
Center	Green
Surround left	Blue
Surround right	Gray
Surround back left	Brown
Surround back right	Tan

The supplied speaker labels are also color-coded and you should attach them to the positive (+) side of each speaker cable in accordance with the above table. Then all you need to do is to match the color of each label to the corresponding speaker terminal.



Speaker Connection Precautions

Read the following before connecting your speakers:

- Only connect speakers with an impedance of 6 ohms or higher. If you use speakers with a lower impedance, and use the amplifier at high volume levels for a long period of time, the built-in protection circuit may be activated.
- Disconnect the power cord from the wall outlet before making any connections.
- Read the instructions supplied with your speakers.
- Pay close attention to speaker wiring polarity. In other words, connect positive (+) terminals only to positive (+) terminals, and negative (–) terminals only to negative (–) terminals. If you get them the wrong way around, the sound will be out of phase and will sound unnatural.
- Unnecessarily long, or very thin speaker cables may affect the sound quality and should be avoided.
- If you use 4 or 5 speakers, connect each of the two surround speakers to the SURROUND SPEAKERS terminals. Do not connect them to the SURROUND BACK SPEAKERS terminals.
- Be careful not to short the positive and negative wires. Doing so may damage the AV receiver.
- Make sure the metal core of the wire does not have contact with the TX-SR603X's rear panel. Doing so may damage the AV receiver.
- Don't connect more than one cable to each speaker terminal. Doing so may damage the AV receiver.
- Don't connect one speaker to several terminals.

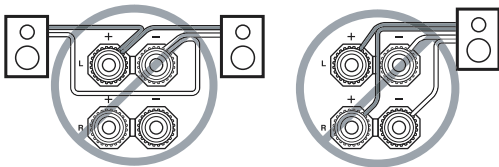
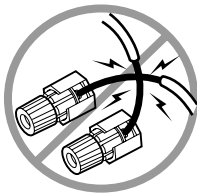

Connecting the Speaker Cables

- 1 Strip about 5/8" (15 mm) of insulation from the ends of the speaker cables, and twist the bare wires tightly, as shown.**
- 2 Unscrew the terminal.**
- 3 Fully insert the bare wires.**
- 4 Screw the terminal tight.**

The following illustration shows which speaker should be connected to each pair of terminals.

If you're using only one surround back speaker, connect it to the left (L) SURROUND BACK SPEAKERS terminals.

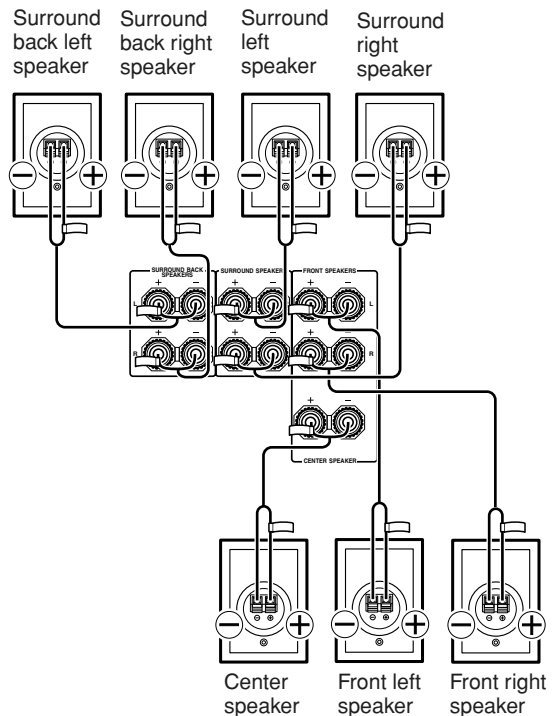

Connecting Antenna

This section explains how to connect the supplied indoor FM antenna and AM loop antenna, and how to connect commercially available outdoor FM and AM antennas. The AV receiver won't pick up any radio signals without any antenna connected, so you must connect the antenna to use the tuner.

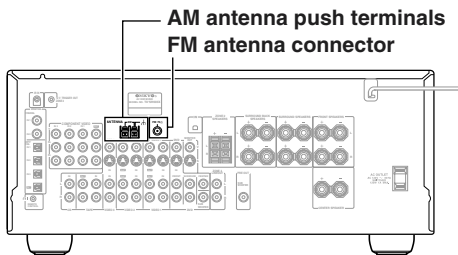

Connecting the Indoor FM Antenna

The supplied indoor FM antenna is for indoor use only.

1 Attach the FM antenna, as shown.

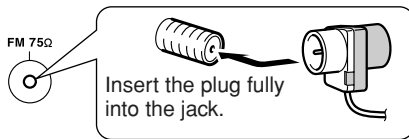

Once your AV receiver is ready for use, you'll need to tune into an FM radio station and adjust the position of the FM antenna to achieve the best possible reception.

2 Use thumbtacks or something similar to fix the FM antenna into position.

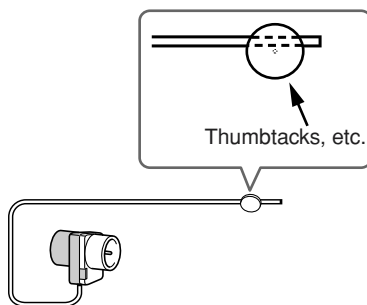

Caution: Be careful that you don't injure yourself when using thumbtacks.

If you cannot achieve good reception with the supplied indoor FM antenna, try a commercially available outdoor FM antenna instead (see page 24).

Connecting the AM Loop Antenna

The supplied indoor AM loop antenna is for indoor use only.

1 Assemble the AM loop antenna, inserting the tabs into the base, as shown.

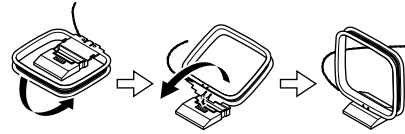

2 Connect both wires of the AM loop antenna to the AM push terminals, as shown.

(The antenna's wires are not polarity sensitive, so they can be connected either way around).

Make sure that the wires are attached securely and that the push terminals are gripping the bare wires, not the insulation.

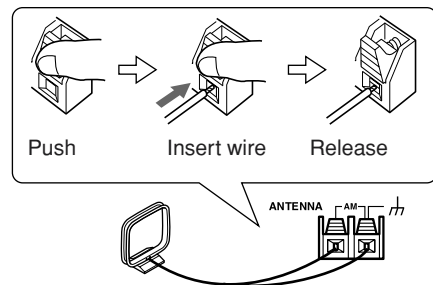

Once your AV receiver is ready for use, you'll need to tune into an AM radio station and adjust the position of the AM antenna to achieve the best possible reception.

Keep the antenna as far away as possible from your AV receiver, TV, speaker cables, and power cords.

If you cannot achieve good reception with the supplied indoor AM loop antenna, try using it with a commercially available outdoor AM antenna (see page 24).

Connecting an Outdoor FM Antenna

If you cannot achieve good reception with the supplied indoor FM antenna, try a commercially available outdoor FM antenna instead.

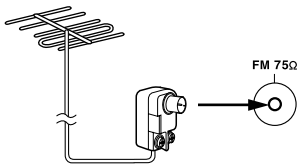

Notes:

- Outdoor FM antennas work best outside, but usable results can sometimes be obtained when installed in an attic or loft.
- For best results, install the outdoor FM antenna well away from tall buildings, preferably with a clear line of sight to your local FM transmitter.
- Outdoor antenna should be located away from possible noise sources, such as neon signs, busy roads, etc.
- For safety reasons, outdoor antenna should be situated well away from power lines and other high-voltage equipment.
- Outdoor antenna must be grounded in accordance with local regulations to prevent electrical shock hazards.

■ Using a TV/FM Antenna Splitter

It's best not to use the same antenna for both FM and TV reception, as this can cause interference problems. If circumstances demand it, use a TV/FM antenna splitter, as shown.

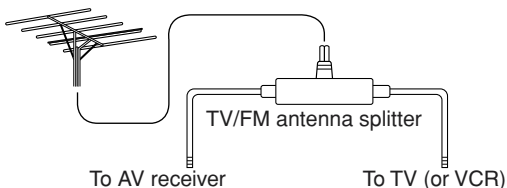

Connecting an Outdoor AM Antenna

If good reception cannot be achieved using the supplied AM loop antenna, an outdoor AM antenna can be used in addition to the loop antenna, as shown.

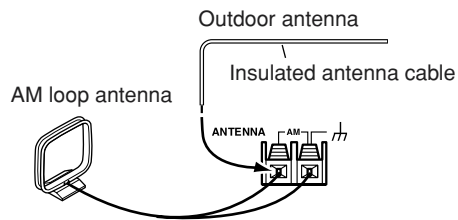

Outdoor AM antennas work best when installed outside horizontally, but good results can sometimes be obtained indoors by mounting horizontally above a window. Note that the AM loop antenna should be left connected. Outdoor antenna must be grounded in accordance with local regulations to prevent electrical shock hazards.

Connecting Both Audio & Video

By connecting both the audio and video outputs of your DVD player and other AV components to the AV receiver, you can select both the audio and video simultaneously simply by selecting the appropriate input source on the AV receiver.

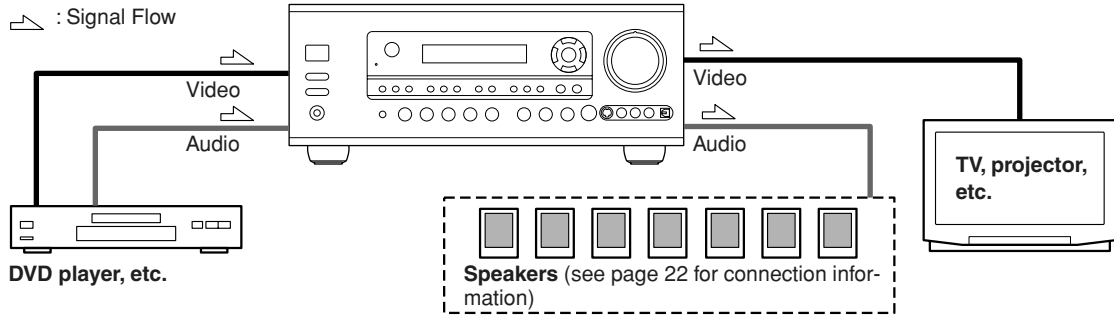

Which Connections Should I Use?

The AV receiver supports several connection formats for compatibility with a wide range of AV equipment. The format you choose will depend on the formats supported by your other components. Use the following sections as a guide. For video components, you must make two connections—one for audio, one for video.

Video Connection Formats

Video equipment can be connected to the AV receiver by using any one of the following video connection formats: composite video, S-Video, or component video, the latter offering the best picture quality.

A video signal connected to a V or S IN jack will be converted—composite video to S-Video or S-Video to composite video—but only for the MONITOR OUT jacks, not the VIDEO 1 and VIDEO 2 OUT V and S jacks.

Note: The TX-SR603X can be set to upconvert composite video and S-Video input signals and output them from the COMPONENT VIDEO OUT (see page 43).

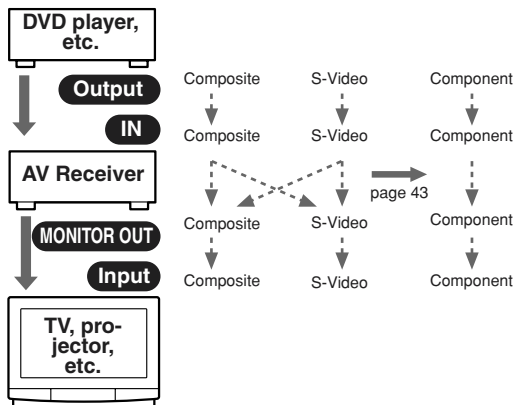

Audio Connection Formats

Audio equipment can be connected to the AV receiver by using any of the following audio connection formats: analog, optical, coaxial, or multichannel.

When choosing a connection format, bear in mind that the AV receiver doesn't convert between them. For example, audio signals connected to an OPTICAL or COAXIAL input are not output by the analog TAPE OUT.

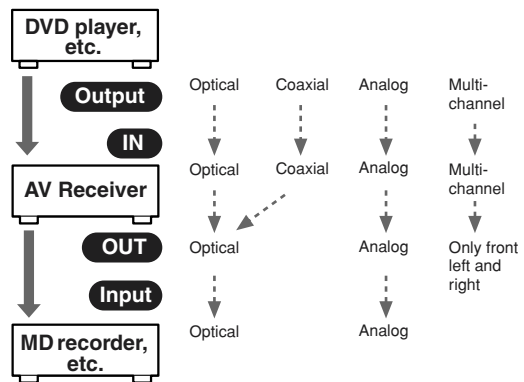

Connecting Your TV or Projector

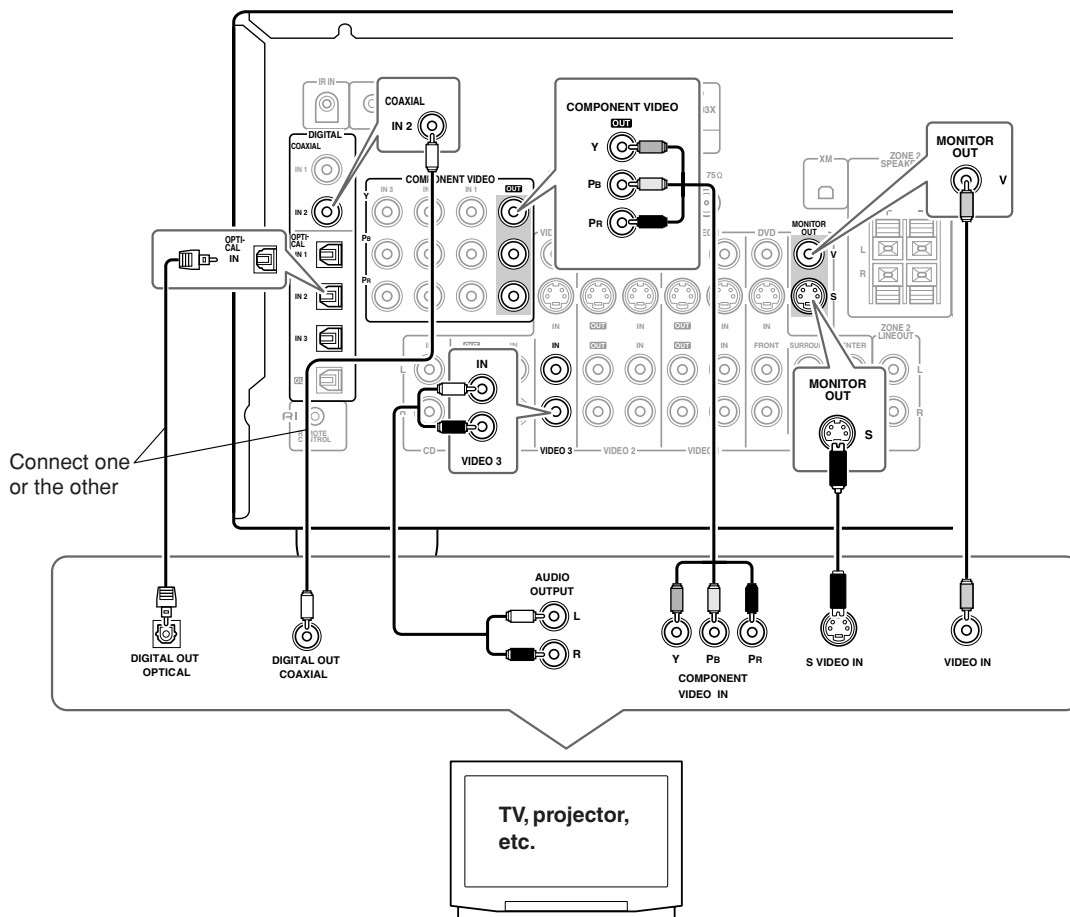

Monitor Out

You only need to use one of the following connection methods.

■ Using Composite Video

Use a composite video cable to connect the AV receiver's V MONITOR OUT jack to a composite video input on your TV, as shown.

■ Using S-Video

Use an S-Video cable to connect the AV receiver's S MONITOR OUT jack to an S-Video input on your TV, as shown.

■ Using Component Video

Use a component video cable to connect the AV receiver's COMPONENT VIDEO OUT jacks to a component video input on your TV, as shown.

Audio Connections

These connections will allow you to listen to audio from your TV via the AV receiver.

If your TV doesn't have an audio output, connect the AV receiver to your VCR and use its tuner (see page 29).

■ Using Coaxial or Optical Connections

If you connect to a digital audio input, you'll need to assign it (see page 42).

- Use an optical digital audio cable to connect one of the AV receiver's OPTICAL DIGITAL IN jacks to an optical output on your TV, as shown.

OR

- Use a coaxial digital audio cable to connect one of the AV receiver's COAXIAL DIGITAL IN jacks to a coaxial output on your TV, as shown.

■ Using Analog Connections

If your TV doesn't have a digital audio output, or you want to record from it, you'll need to make the following analog audio connection.

Use an analog audio cable to connect the AV receiver's VIDEO 3 IN L/R jacks to an analog audio output on your TV, as shown.

Connecting a DVD Player

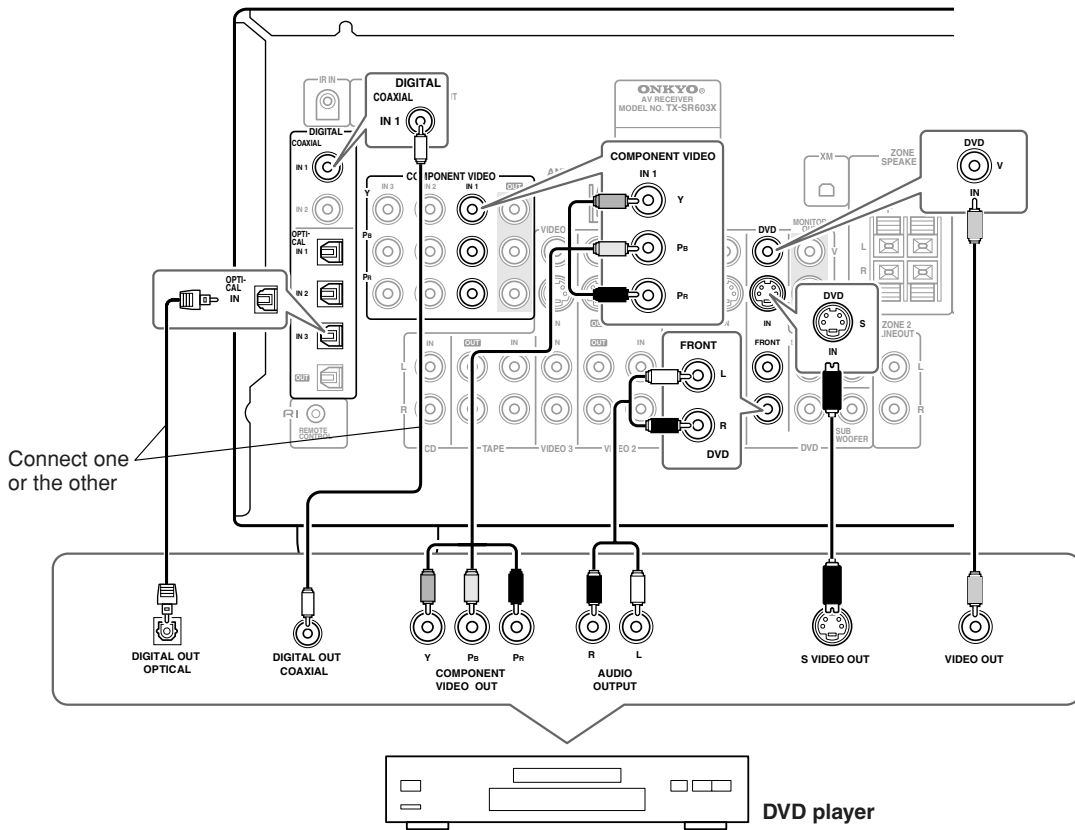

Video Connections

You only need to use one of the following connection methods.

■ Using Composite Video

Use a composite video cable to connect the AV receiver's V DVD IN jack to the composite video output on your DVD player, as shown.

■ Using S-Video

Use an S-Video cable to connect the AV receiver's S DVD IN jack to the S-Video output on your DVD player, as shown.

■ Using Component Video

Use a component video cable to connect the AV receiver's COMPONENT VIDEO IN1 jacks to the component video output on your DVD player, as shown.

- Your TV must also be connected via component video.

Audio Connections

■ Using Coaxial or Optical Connections

- Use a coaxial digital audio cable to connect one of the AV receiver's COAXIAL DIGITAL IN jacks to the coaxial output on your DVD player, as shown.

OR

- Use an optical digital audio cable to connect one of the AV receiver's OPTICAL DIGITAL IN jacks to the optical output on your DVD player, as shown. Initially, the COAXIAL IN 1 jack is assigned to the DVD input source. If you connect your DVD player to a different digital input, you'll need to reassign the DVD input source (see page 42).

■ Using Analog Connections

Even if your DVD player is connected digitally (optical or coaxial), to use **RI**, or to record audio from your DVD player, you'll need to make an analog connection as well.

Use an analog audio cable to connect the AV receiver's DVD IN L/R jacks to the analog audio output on your DVD player, as shown.

If your DVD player has stereo (L/R) and multichannel outputs, be sure to use the left and right outputs.

■ Using a Multichannel Connection

If your DVD player supports multichannel audio formats such as DVD-Audio, and it has a 5.1-channel analog audio output, you can enjoy DVD-Audio playback.

Use a multichannel analog audio cable to connect the AV receiver's DVD IN FRONT L/R, CENTER, SURROUND L/R, and SUBWOOFER jacks to the 5.1-channel analog audio output on your DVD player, as shown. Alternatively, use several analog audio cables.

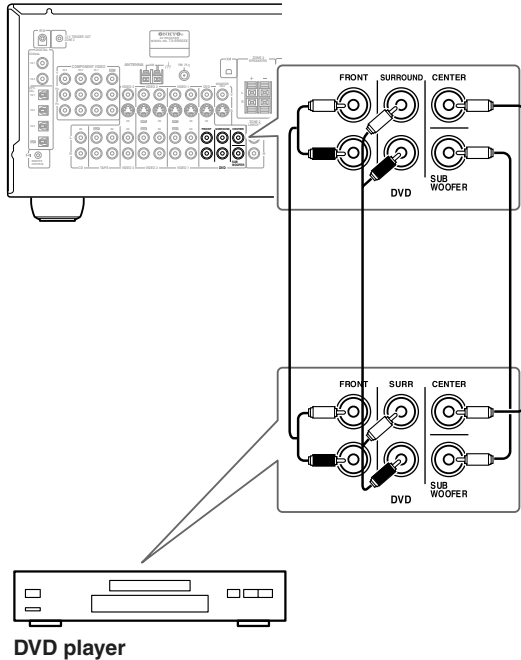

Connecting a VCR for Playback

This section shows how to connect a VCR for playback so that you can watch videos via the AV receiver.

Video Connections

- Use an S-Video cable to connect the AV receiver's S VIDEO 1 IN jack to a S-Video output on your VCR, as shown.

OR

- Use a composite video cable to connect the AV receiver's V VIDEO 1 IN jack to a composite video output on your VCR, as shown.

An S-Video connection provides better picture quality than a composite video connection.

Audio Connections

- Use an analog audio cable to connect the AV receiver's VIDEO 1 IN L/R jacks to an analog audio output on your VCR, as shown.

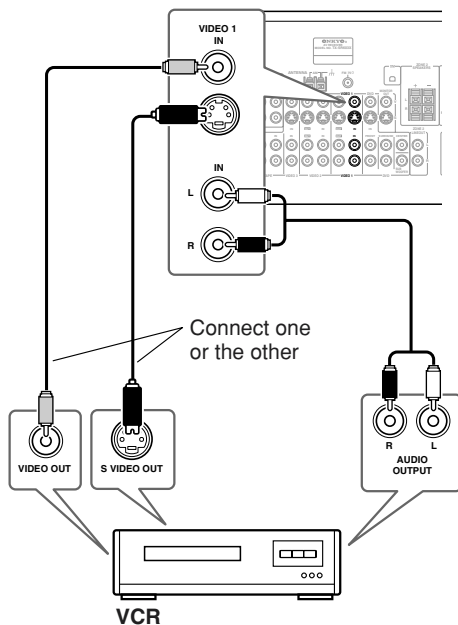

Connecting an HDD/DVD recorder for Playback

Video Connections

With the initial settings of the TX-SR603X, the VIDEO 1 input source is set for the COMPONENT VIDEO IN 2 jacks. If you connect the device to the COMPONENT VIDEO IN 3 jacks, see page 43.

Use a component video cable to connect the AV receiver's COMPONENT VIDEO IN2 or 3 jacks to a component video output on your HDD/DVD recorder, as shown. Your TV must also be connected via component video.

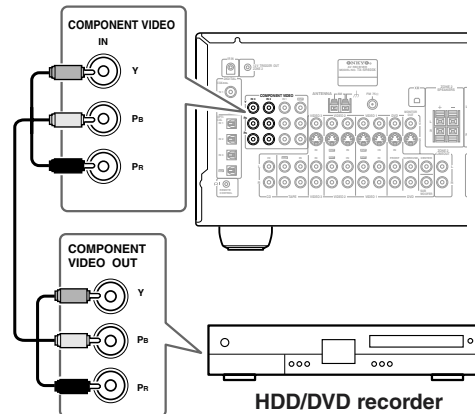

Audio Connections

If you connect to a digital audio input, you'll need to assign it (see page 42).

- Use an optical digital audio cable to connect one of the AV receiver's OPTICAL DIGITAL IN jacks to an optical output on your HDD/DVD recorder, as shown.
- OR
- Use a coaxial digital audio cable to connect one of the AV receiver's COAXIAL DIGITAL IN jacks to a coaxial output on your HDD/DVD recorder, as shown.

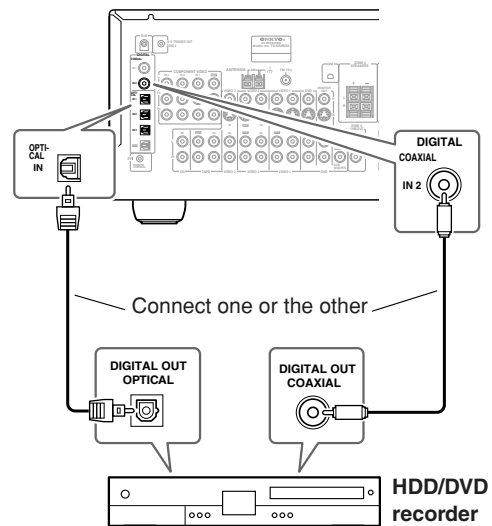

Connecting a VCR for Recording

This section explains how to connect a VCR for recording from a TV or another VCR.

Video Connections

- Use an S-Video cable to connect the AV receiver's S VIDEO 1 OUT jack to an S-Video input on the recording VCR. Use another S-Video cable to connect the AV receiver's S VIDEO 3 IN jack to an S-Video output on your TV or playback VCR, as shown.

OR

- Use a composite video cable to connect the AV receiver's V VIDEO 1 OUT jack to a composite video input on the recording VCR. Use another composite video cable to connect the AV receiver's V VIDEO 3 IN jack to a composite video output on your TV or playback VCR, as shown.

Audio Connections

- Use an analog audio cable to connect the AV receiver's VIDEO 1 OUT L/R jacks to an audio input on the recording VCR.
- Use an analog audio cable to connect the AV receiver's VIDEO 3 IN L/R jacks to an audio output on your TV or playback VCR.

Playback from the Recording VCR

To play back a video in the recording VCR via the AV receiver:

- Use an S-Video cable to connect the AV receiver's S VIDEO 1 IN jack to an S-Video output on the recording VCR.

OR

- Use a composite video cable to connect the AV receiver's V VIDEO 1 IN jack to a composite video output on the recording VCR.

And use an analog audio cable to connect the AV receiver's VIDEO 1 IN L/R jacks to an audio output on the recording VCR.

Notes:

- The AV receiver must be turned on for recording. Recording is not possible while it's in Standby mode.
- If you want to record directly from your TV or playback VCR to the recording VCR without going through the AV receiver, connect the TV/VCR's audio and video outputs directly to the recording VCR's audio and video inputs. See the manuals supplied with your TV and VCR for details.
- Video signals connected to composite video inputs can only be recorded via composite video outputs. If your TV/VCR is connected to a composite video input, the recording VCR must be connected to a composite video output. Similarly, video signals connected to S-Video inputs can only be recorded via S-Video outputs. If your TV/VCR is connected to an

S-Video input, the recording VCR must be connected to an S-Video output.

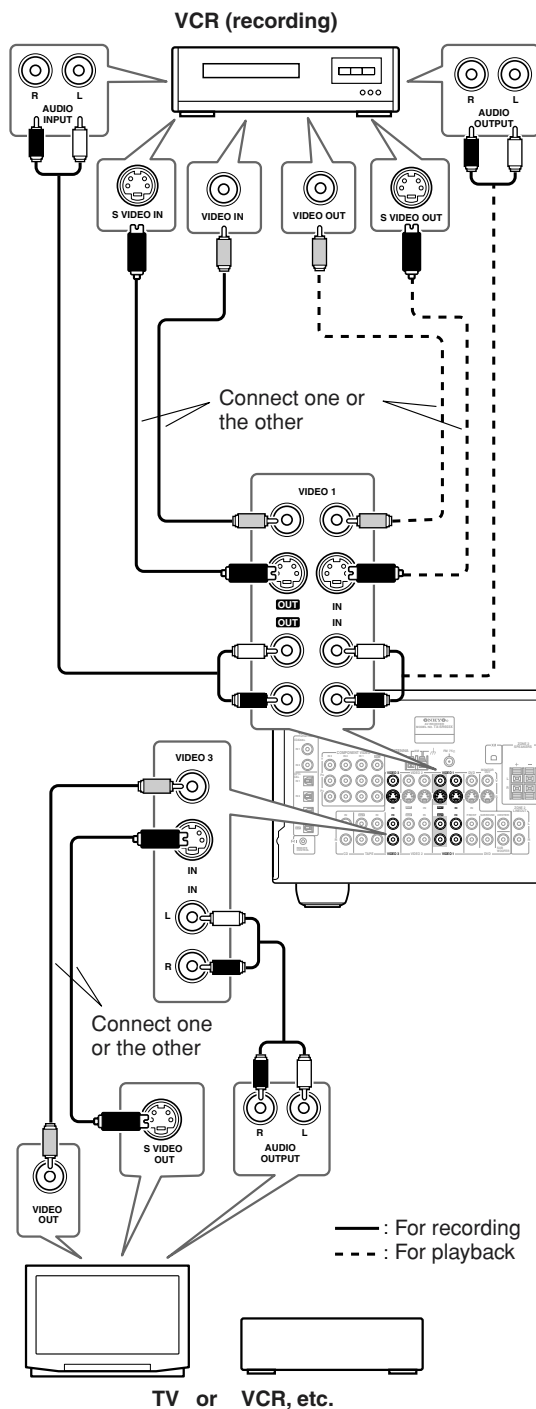

Connecting Other Video Sources— Satellite, Cable, Set-top box, LD Player, etc.

Video Connections

You only need to use one of the following connection methods.

■ Using Composite Video

Use a composite video cable to connect the AV receiver's VIDEO 3 IN jack to a composite video output on your video source, as shown.

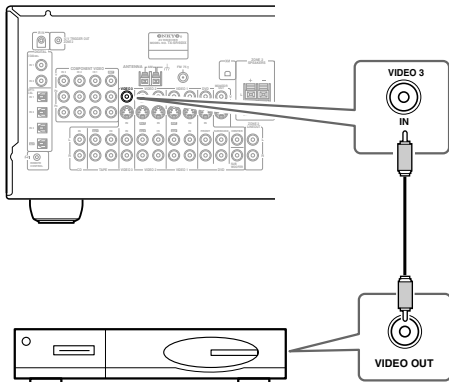

Satellite, cable, set-top box, LD player, etc.

■ Using S-Video

Use an S-Video cable to connect the AV receiver's S VIDEO 3 IN jack to an S-Video output on your video source, as shown.

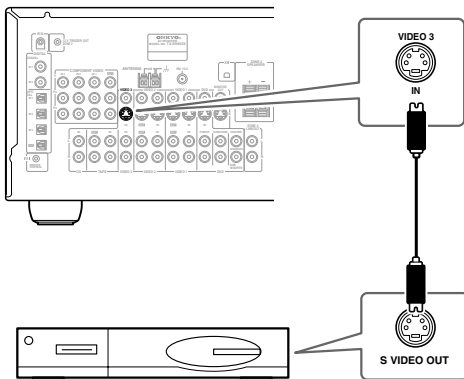

Satellite, cable, set-top box, LD player, etc.

■ Using Component Video

If you connect to a component video input, you must assign it (see page 43).

Use a component video cable to connect the AV receiver's COMPONENT VIDEO IN 2 or IN 3 jack to a component video output on your video source, as shown.

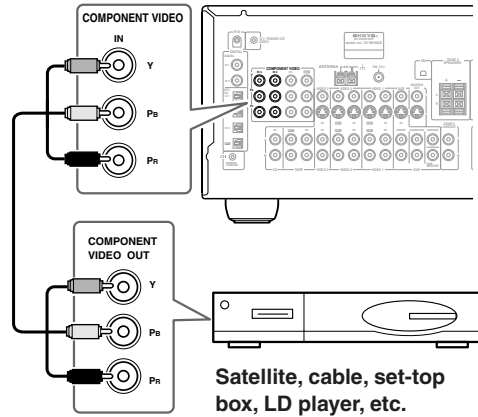

Audio Connections

■ Using Optical or Coaxial Connections

If you connect to a digital audio input, you'll need to assign it (see page 42).

- Use an optical digital audio cable to connect one of the AV receiver's OPTICAL DIGITAL IN jacks to an optical output on your video source, as shown.

OR

- Use a coaxial digital audio cable to connect one of the AV receiver's COAXIAL DIGITAL IN jacks to a coaxial output on your video source, as shown.

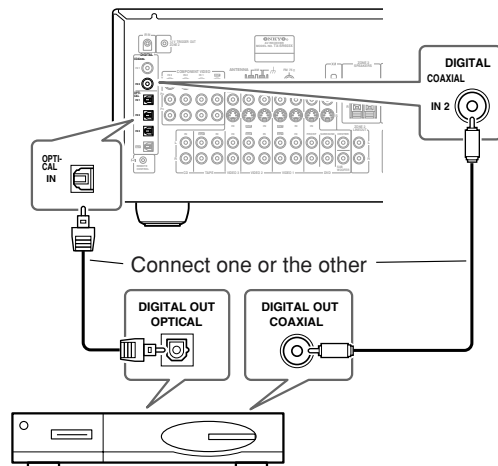

Satellite, cable, set-top box, LD player, etc.

Note:

To connect the AV receiver to an LD player's AC-3RF output, you need a commercially available demodulator.

Connecting the AV Receiver—Continued

■ Using Analog Connections

If your video source doesn't have a digital audio output, or you want to record from it, you'll need to make the following analog audio connection.

Use an analog audio cable to connect the AV receiver's VIDEO 3 IN L/R jacks to the analog audio output on your video source, as shown.

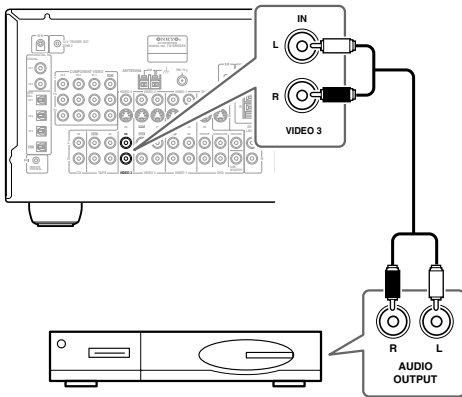

Satellite, cable, set-top box, LD player, etc.

Connecting a Camcorder, Game Console, etc.

Video Connections

You only need to use one of the following connection methods.

■ Using Composite Video

Use a composite video cable to connect the AV receiver's VIDEO 4 INPUT VIDEO jack to the composite video output on your camcorder, game console, etc., as shown.

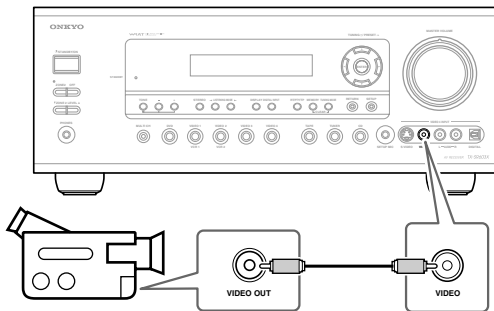

Camcorder, game console, etc.

■ Using S-Video

Use an S-Video cable to connect the AV receiver's VIDEO 4 INPUT S VIDEO jack to the S-Video output on your camcorder, game console, etc., as shown.

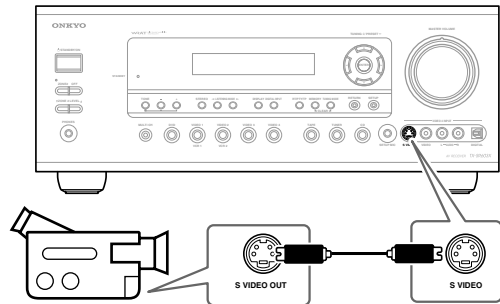

Camcorder, game console, etc.

Audio Connections

Use an analog audio cable to connect the AV receiver's VIDEO 4 INPUT AUDIO L/R jacks to the analog audio output on your camcorder, game console, etc., as shown.

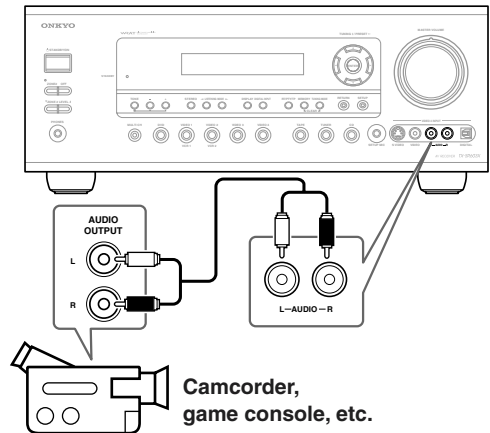

Camcorder, game console, etc.

If your camcorder, game console, etc., has an optical digital audio output, use an optical digital audio cable to connect it to the AV receiver's VIDEO 4 INPUT DIGITAL jack, as shown.

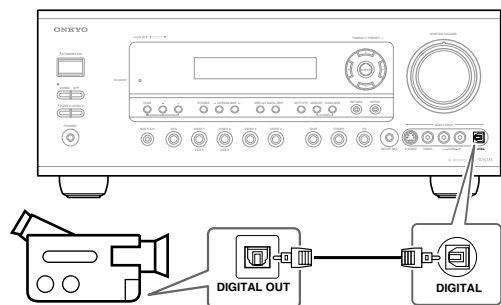

Camcorder, game console, etc.

Connecting a CD Player

■ Using Optical or Coaxial Connections

If you connect to a digital audio input, you'll need to assign it (see page 42).

- Use an optical digital audio cable to connect one of the AV receiver's OPTICAL DIGITAL IN jacks to the optical output on your CD player, as shown.

OR

- Use a coaxial digital audio cable to connect one of the AV receiver's COAXIAL DIGITAL IN jacks to the coaxial output on your CD player, as shown.

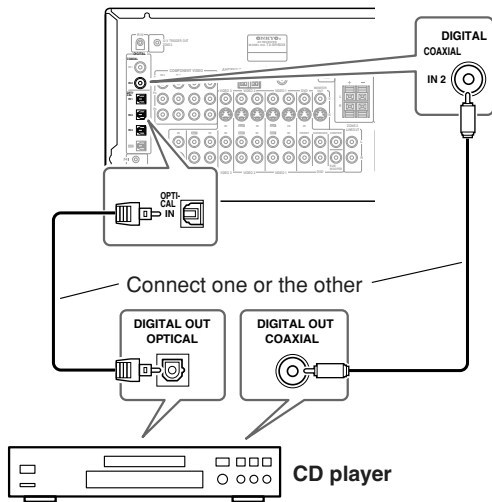

■ Using Analog Connections

Even if your CD player is connected digitally (coaxial or optical), to use **RI**, or to record audio from your CD player, you'll need to make an analog audio connection as well.

Use an analog audio cable to connect the AV receiver's CD IN L/R jacks to the analog audio output on your CD player, as shown.

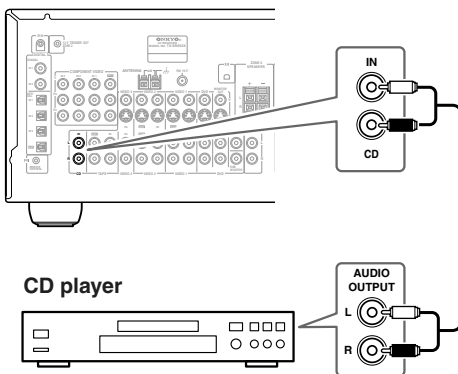

Connecting a Cassette Recorder

Use an analog audio cable to connect the AV receiver's TAPE IN L/R jacks to the cassette recorder's output, and use another analog audio cable to connect the AV receiver's TAPE OUT L/R jacks to the cassette recorder's input, as shown.

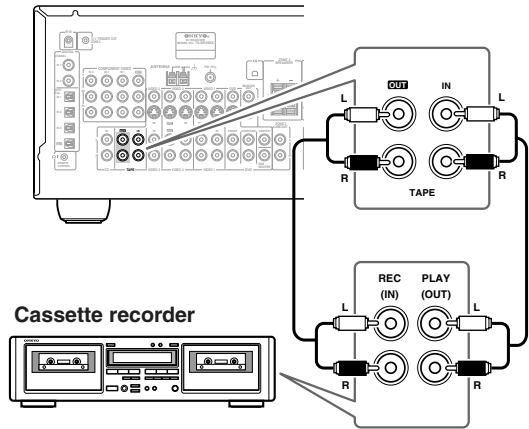

Connecting a DAT, CD, or MD Recorder

You can connect a DAT, CD, or MD recorder instead of a cassette recorder.

■ Analog Connections

Use an analog audio cable to connect the AV receiver's TAPE IN L/R jacks to the recorder's output, and use another analog audio cable to connect the AV receiver's TAPE OUT L/R jacks to the recorder's input, as shown.

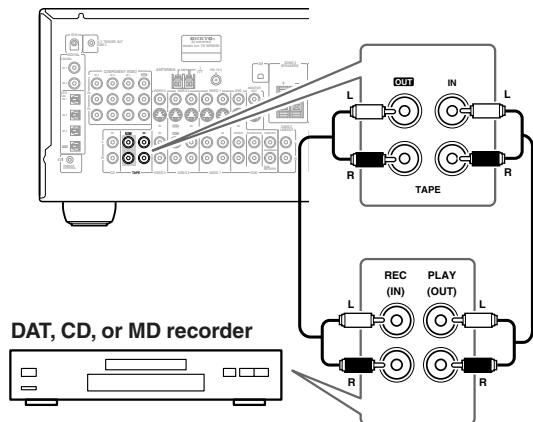

■ Using Optical or Coaxial Connections (playback only)

If you connect to a digital audio input, you'll need to assign it (see page 42).

- Use an optical digital audio cable to connect one of the AV receiver's OPTICAL DIGITAL IN jacks to the optical output on your recorder, as shown.

OR

- Use a coaxial digital audio cable to connect one of the AV receiver's COAXIAL DIGITAL IN jacks to the coaxial output on your recorder, as shown.

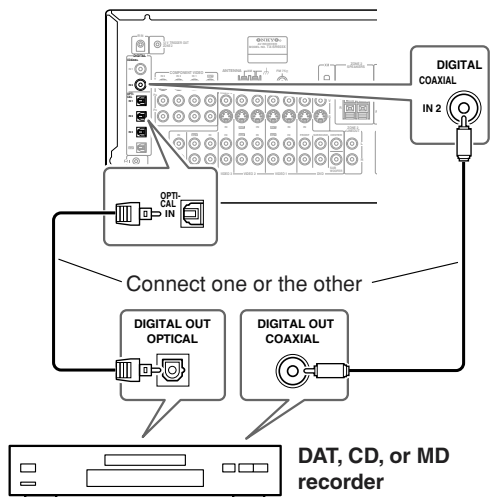

■ Digital Recording

If your recorder has a digital input, by connecting it to the AV receiver's optical DIGITAL OUT jack, you can record digitally. However, because the AV receiver doesn't convert analog input signals to digital and vice versa, only input signals connected to a DIGITAL IN jack can be recorded in this way.

Digital source (DAT, CD, MD player)

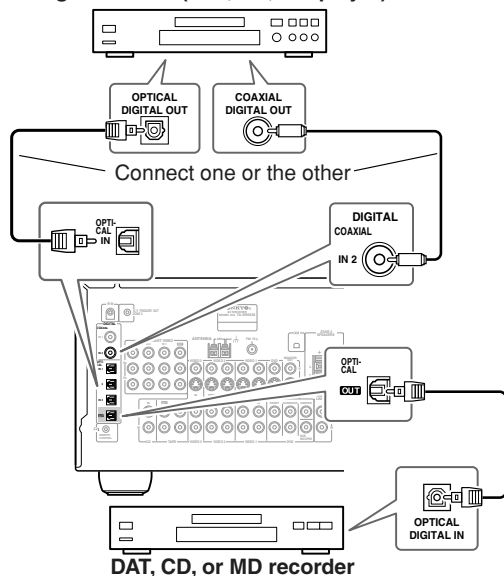

Connecting a Turntable

■ Turntable with a Built-in Phono Preamp

Use an analog audio cable to connect an unused audio input on the AV receiver to the audio outputs on your turntable, as shown.

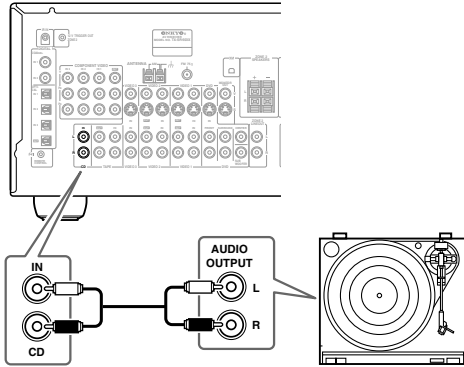

■ Turntable without a Built-in Phono Preamp

Use an analog audio cable to connect an unused audio input on the AV receiver to the audio outputs on your phono preamp, and use another analog audio cable to connect the phono preamp's inputs to your turntable, as shown.

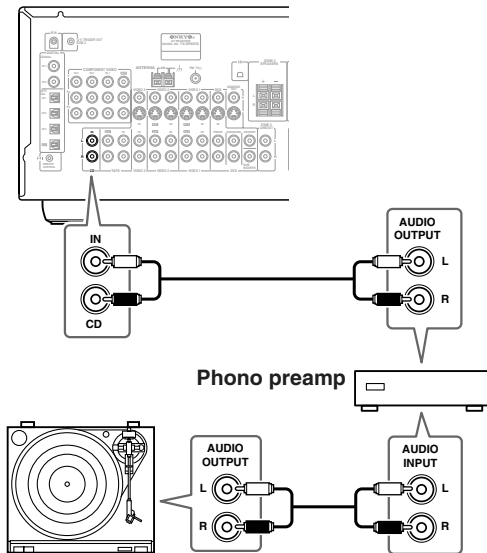

■ Turntable with an MC (Moving Coil) Cartridge

Use an analog audio cable to connect an unused audio input on the AV receiver to the audio outputs on your phono preamp. Use another analog audio cable to connect the phono preamp's inputs to your MC head amp's outputs. And use another analog audio cable to connect the MC head amp's inputs to your turntable, as shown. For further information, see the manual for your turntable or phono preamp.

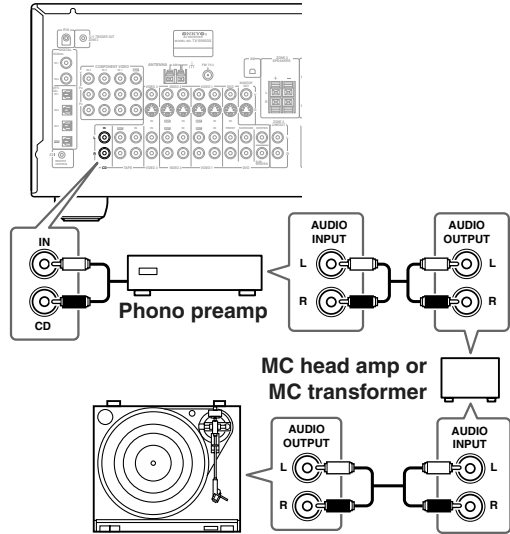

Connecting RI Components

With **RI** (Remote Interactive) you can control your **RI**-compatible Onkyo CD player, DVD player, and so on with the AV receiver's remote controller, as follows:

- To use **RI**, you must make an analog audio connection between the AV receiver and the other AV components, even if they are connected digitally.

Auto Power On/Standby

When you start playback on an AV component connected via **RI**, if the AV receiver is in Standby, it will turn on and select that AV component as the input source automatically. Similarly, when the AV receiver is set to Standby, all components connected via **RI** also enter Standby. Note that this function will not work if the component's power cord is connected to the AV receiver's AC OUTLET.

Direct Change

When playback is started on an AV component connected via **RI**, the AV receiver automatically selects that AV component as the input source.

Remote Control

You can control your **RI**-compatible Onkyo components with the AV receiver's remote controller.

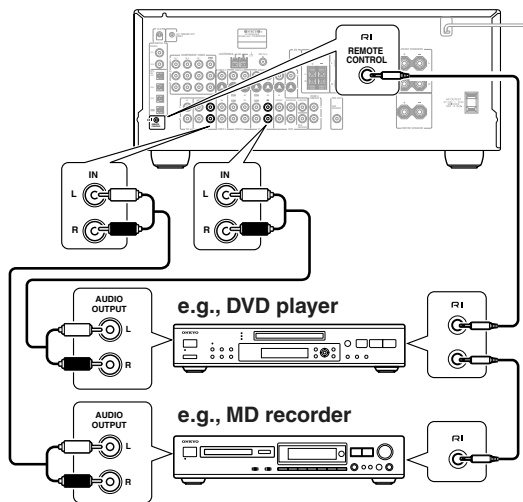

Notes:

- If you connect an **RI**-compatible Onkyo MiniDisc recorder or CD recorder to the TAPE IN/OUT jacks, for **RI** to work properly, you must change the TAPE/MD/CDR display (see page 50).
- Push plugs in all the way to make good connections.
- Use only **RI** cables for **RI** connections. No **RI** cables are supplied with this AV receiver.
- Some AV components have two **RI** jacks. You can connect either one to this AV receiver. The other jack is for connecting more **RI**-compatible components.
- Connect the AV receiver's **RI** jack to only Onkyo AV components. Connecting to other manufacturer's AV components may cause them to malfunction.
- Some components may not support all **RI** functions. Refer to the manuals supplied with your components.

Connecting the Power Cord of Another Component

The AV receiver has an AC outlet on its rear panel for connecting the power cord of another AV component. The other component's power switch can then be left in the ON position so that it turns on or off when the AV receiver is set to On or Standby.

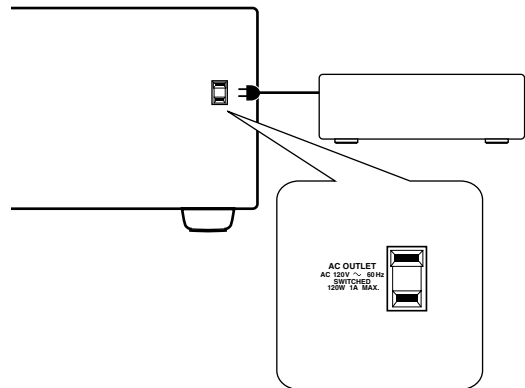

Caution:

Make sure that the capacity of the component that you connect to the AC OUTLET does not exceed the stated capacity (e.g., 120 W).

Notes:

- Onkyo components with **RI** jacks should be connected directly to wall outlets, not the AV receiver's AC OUTLET.
- The socket type and capacity will depend on the country in which you purchased the AV receiver.

Turning On the AV Receiver

- Before connecting the power cord, connect all your speakers and AV components.
- Turning on the AV receiver may cause a momentary power surge that might interfere with other electrical equipment on the same circuit. If this is a problem, plug the AV receiver into a different circuit.

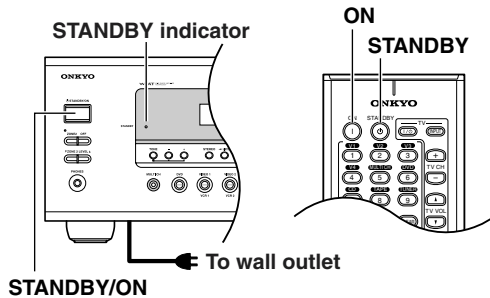

1

STANDBY



Plug the power cord into an AC wall outlet.

The STANDBY indicator will light up.

2

STANDBY/ON



Remote controller

ON



STANDBY



Press the [STANDBY/ON] button. Alternatively, press the remote controller's [RECEIVER] button followed by the [ON] button.

The AV receiver comes on, the display lights up, and the STANDBY indicator goes off.

To turn off the AV receiver, press the [STANDBY/ON] button. The AV receiver will enter Standby mode.

Notes:

- Pressing the remote controller's [ON] button once will turn on the AV receiver. Pressing it again will turn on any components connected via **RI**.
- When the AV receiver is on Standby, it will turn on automatically when any one of its input selector buttons is pressed.
- Before disconnecting the power cord from the wall outlet, set the AV receiver to Standby.

First Time Setup

This chapter explains the settings that you need to make before using the AV receiver.

Automatic Speaker Setup

With the supplied speaker setup microphone, the Automatic Speaker Setup function can measure the test tone output by each speaker and automatically determine the number of speakers connected, their sizes, the distance from each speaker to the listening position, and so on. Before using this function, connect and position all your speakers.

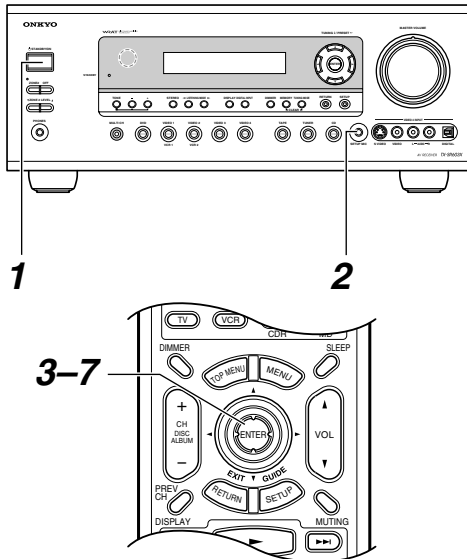

- 1 Turn on the AV receiver and the connected TV.**
On the TV, select the input to which the AV receiver is connected.

2

Put the speaker setup microphone in the listening position, and connect it to the SETUP MIC jack.

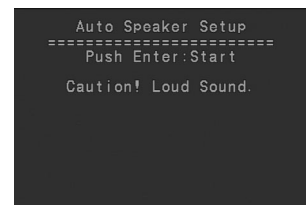
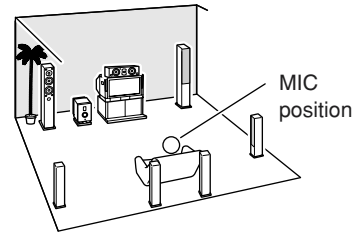

Notes:

- Make sure the microphone is horizontal.
- If there's an obstacle between the microphone and any speaker, the automatic setup will not work correctly. Setup the room as you would when enjoying a DVD.
- If the AV receiver was previously muted, the Muting function will be cancelled.
- The automatic setup cannot be used while a pair of headphones is connected.
- By putting the microphone close to where your ears would normally be at the listening position, a more accurate setup can be achieved. If you use a tripod or level table, you can adjust the height of the microphone.

3



Press [ENTER].

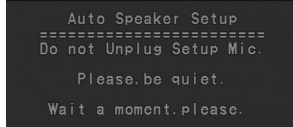

The automatic speaker setup starts. The test tone is output by each speaker in turn, measured by the microphone, and the speaker settings set accordingly. The whole process takes about 2 minutes.

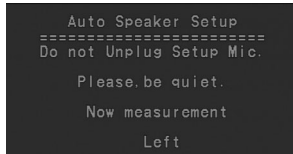

If any extraneous noise is picked up by the microphone, the automatic setup may not work correctly, so be careful.

4

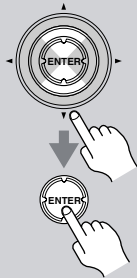

Once the measurement is completed, the following completion screen appears.

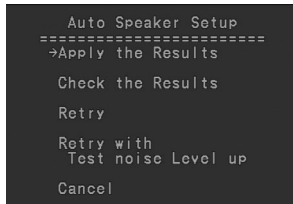

Use the Up and Down [▲]/[▼] buttons to select any of the following options, and then press [ENTER].

Apply the Results:

Validates the measurement results and closes the screen. Normally you may want to select this option. Continue with step 5.

Check the Results:

Displays the measurement results for your reference. Continue with “How to Verify the Measurement Results” described below.

Retry:

Retries measurement. Return to step 2.

Retry with Test noise Level up:

Retries measurement with the test sound at high volume level. Return to step 2.

Cancel:

Closes the screen without validating the measurement results. Continue with step 5.

5

Disconnect the speaker setup microphone.

To cancel the automatic setup while it's in progress, disconnect the microphone.

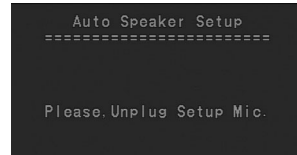

■ **How to Verify the Measurement Results**

By selecting “Check the Results” at step 4, you can display the following screen to confirm the measurement results.

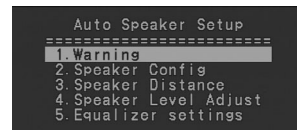
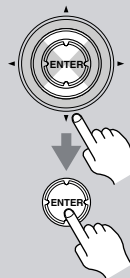

- 1 Warning
- 2 Number of speakers and their sizes
- 3 Distance from each speaker to the listening position
- 4 The optimum volume level for each speaker
- 5 The level adjustment for individual frequency range covered by respective speaker

Use the Up and Down [▲]/[▼] buttons to select the item that you want to check, and then press [ENTER].

Press the [RETURN] button to return to the previous display.

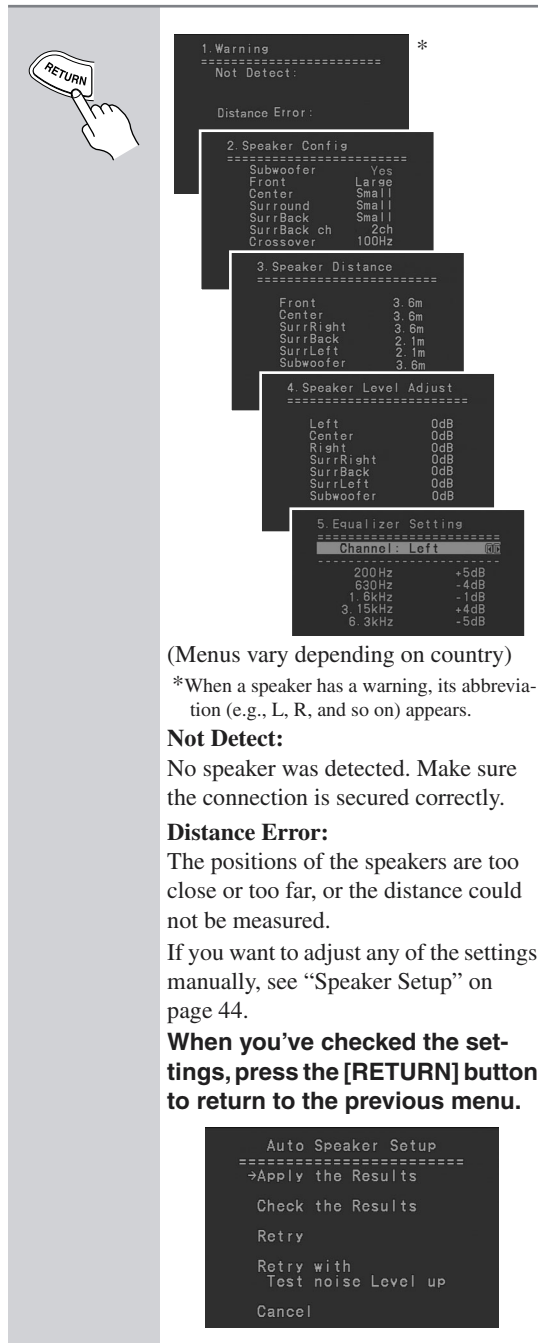

results confirmation screen, turn the volume up to an appropriate level and the frequency as high as it can go. And then turn on the Direct switch, if available. For further information, see the manual for the subwoofer.

(Menus vary depending on country)

*When a speaker has a warning, its abbreviation (e.g., L, R, and so on) appears.

Not Detect:

No speaker was detected. Make sure the connection is secured correctly.

Distance Error:

The positions of the speakers are too close or too far, or the distance could not be measured.

If you want to adjust any of the settings manually, see “Speaker Setup” on page 44.

When you’ve checked the settings, press the [RETURN] button to return to the previous menu.

Note:

Measurement may not be performed correctly depending on your use environment. If the measurement results remain unchanged after retried, create speaker settings manually (see pages 44-49).

Tip:

When any amplifier-builtin subwoofer is connected, its sound may not be detected with the automatic speaker settings because the sound is generated from the low position with very low frequencies. If the subwoofer (SW) is specified as “Not Detect” in the measurement

About the Onscreen Setup Menus

The AV receiver is configured using onscreen setup menus, which are displayed on the TV that's connected to either of the MONITOR OUT jacks. Because they appear on your TV, they're large and clear, making setup a breeze.

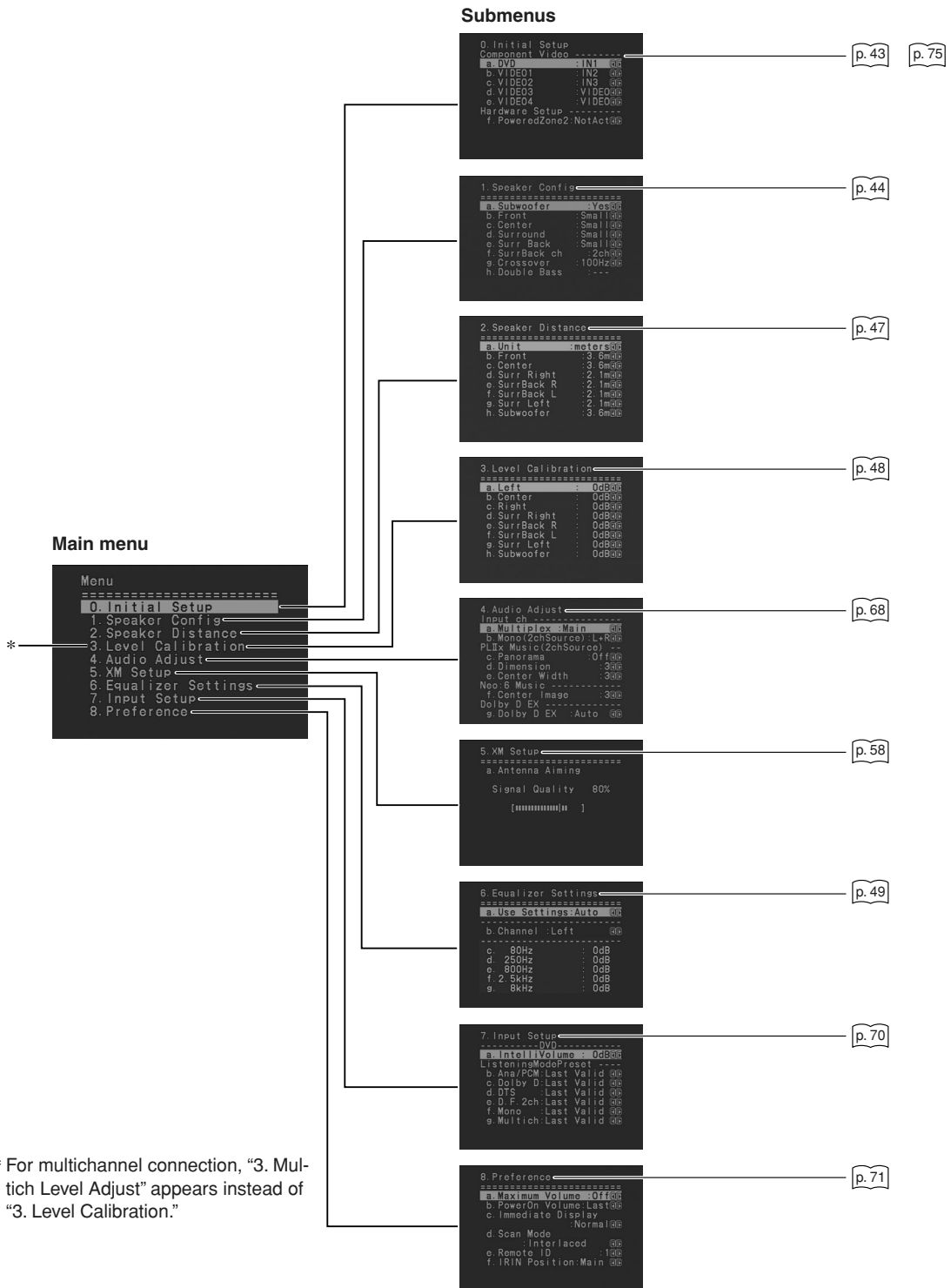

Initial Setup

Digital Input

If you connect a component to a digital input jack, you must assign that jack to an input selector. For example, if you connect your CD player to the OPTICAL IN2 jack, you should assign that jack to the CD input selector. By default, the COAXIAL IN1 jack is assigned to the DVD input selector, although this can be changed.

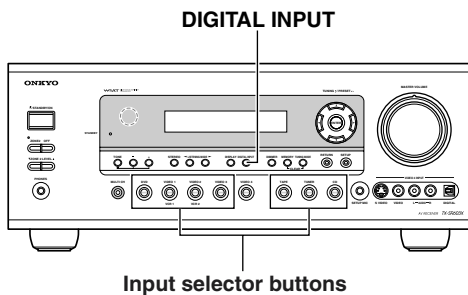

Examples:

If you connect your DVD player to the OPTICAL IN 2 jack, set “DVD” to “OPT2.”

If you want to listen to audio from the component connected to the OPTICAL IN 3 jack when the VIDEO 1 input selector is selected, set “VIDEO1” to “OPT3.”

If you want to listen to audio from the component connected to the COAXIAL IN 1 jack when the VIDEO 2 input selector is selected, set “VIDEO2” to “COAX1.”

For input selectors that you don’t want to assign a digital input jack, set to “---- (analog).”

1

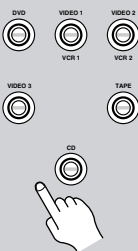

Press the input selector button for the source that you want to assign.

(Digital inputs cannot be assigned to the TUNER input source)

2



Press the [DIGITAL INPUT] button.

The current assignment appears.

DVD #COAX1

3



Press the [DIGITAL INPUT] button repeatedly to select COAX1, COAX2, OPT1, OPT2, OPT3, or ---- (analog).

- There are no assignments for TUNER.
- VIDEO 4 is used only for digital input from the front panel terminals.

Component Video Setup

If you connect to a COMPONENT VIDEO IN, you must assign it to an input selector. For example, if you connect your DVD player to COMPONENT IN 3, you should assign it to the DVD input selector.

If you want to output composite and S-Video sources from the COMPONENT VIDEO OUT, select VIDEO, as explained below.

Input selector	VIDEO IN jack
DVD	IN 1
VIDEO 1	IN 2
VIDEO 2	IN 3
VIDEO 3	VIDEO
VIDEO 4	VIDEO

4



Press the [SETUP] button.

The setup menu closes.

Note:

This procedure can also be performed on the AV receiver by using its [SETUP] button, arrow buttons, and [ENTER] button.

1



Press the [RECEIVER] button followed by the [SETUP] button.

The main menu appears onscreen.

2

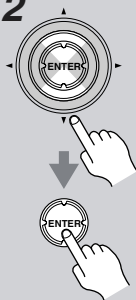

Use the Up and Down [▲]/[▼] buttons to select “0. Initial Setup,” and then press [ENTER].

The Initial Setup menu appears.

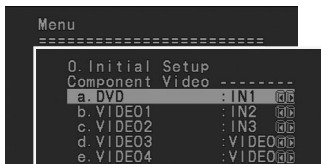

3



Use the Up and Down [▲]/[▼] buttons to select an input selector, and then use the Left and Right [◀]/[▶] buttons to select:

- IN1:** Use the video component connected to COMPONENT VIDEO IN 1.
- IN2:** Use the video component connected to COMPONENT VIDEO IN 2.
- IN3:** Use the video component connected to COMPONENT VIDEO IN 3.

VIDEO: Output composite video and S-Video sources from the COMPONENT VIDEO OUT.

Speaker Setup

Some of the settings in this section are set automatically by the Automatic Speaker Setup function (see page 38). Here you can check the settings made by the Automatic Speaker Setup function, or set them manually, which is useful if you change one of the connected speakers after using the Automatic Speaker Setup function.

Speaker Configuration

This setting is set automatically by the Automatic Speaker Setup function (see page 38).

Here you can specify which speakers are connected and their individual sizes.

For speakers with a cone diameter over 6-1/2 inches (16 cm), specify *large*, and for those with a diameter below this, specify *small*.

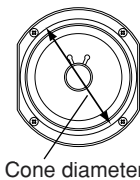

Cone diameter

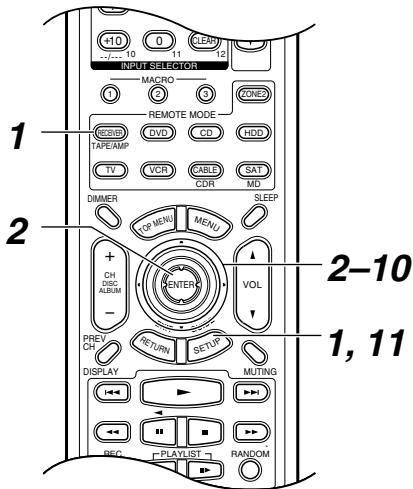

1 Press the [RECEIVER] button followed by the [SETUP] button. The main menu appears onscreen.

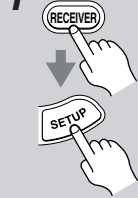

2 Use the Up and Down [▲]/[▼] buttons to select “1. Speaker Config,” and then press [ENTER]. The Speaker Config menu appears.

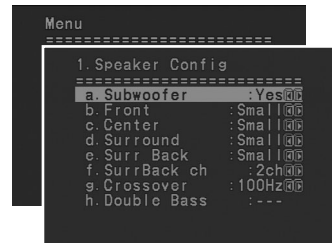
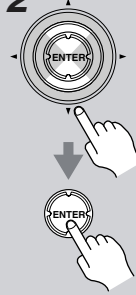

3 Use the Up and Down [▲]/[▼] buttons to select “a. Subwoofer,” and then use the Left and Right [◀]/[▶] buttons to select:

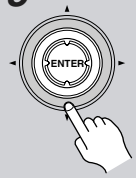

- Yes:** Select if a subwoofer is connected.
- No:** Select if no subwoofer is connected.

4 Use the Up and Down [▲]/[▼] buttons to select “b. Front,” and then use the Left and Right [◀]/[▶] buttons to select:



- Small:** Select if the front speakers are small.
- Large:** Select if the front speakers are large.

Note: If the Subwoofer setting in step 3 is set to No, this setting is fixed at Large.

5 Use the Up and Down [▲]/[▼] buttons to select “c. Center,” and then use the Left and Right [◀]/[▶] buttons to select:



- Small:** Select if the center speaker is small.
- Large:** Select if the center speaker is large.
- None:** Select if no center speaker is connected.

Note: If the Front setting in step 4 is set to Small, the Large option cannot be selected.

6



Use the Up and Down [▲]/[▼] buttons to select “d. Surround,” and then use the Left and Right [◀]/[▶] buttons to select:

- Small:** Select if the surround left and right speakers are small.
- Large:** Select if the surround left and right speakers are large.
- None:** Select if no surround left and right speakers are connected.

Note:

If the Front setting in step 4 is set to Small, the Large option cannot be selected.

7



Use the Up and Down [▲]/[▼] buttons to select “e. SurrBack,” and then use the Left and Right [◀]/[▶] buttons to select:

- Small:** Select if the surround back left and right speakers are small.
- Large:** Select if the surround back speakers are large.
- None:** Select if no surround back speakers are connected.

Notes:

- If the Surround setting in step 6 is set to None, this setting cannot be selected.
- If the Surround setting in step 6 is set to Small, this setting cannot be set to Large.

8



Use the Up and Down [▲]/[▼] buttons to select “f. SurrBack ch,” and then use the Left and Right [◀]/[▶] buttons to select:

- 1ch:** Select if one surround back speaker is connected.
- 2ch:** Select if two (left and right) surround back speakers are connected.

Note:

If the Surround Back Setting in step 7 is set to None, this setting cannot be selected.

Continue with step 9 in the right column.

Crossover

9



Use the Up and Down [▲]/[▼] buttons to select “g. Crossover,” and then use the Left and Right [◀]/[▶] buttons to select a crossover frequency.

Choose a crossover frequency suitable for your setup. If you’re using a subwoofer, choose a crossover frequency based on the diameter of your front speakers. If you’re not using a subwoofer, use the diameter of any speaker that you specified as Small.

Speaker cone diameter	Crossover frequency
Over 8 in. (20 cm)	60 Hz
6-1/2 to 8 in. (16–20 cm)	80 Hz
5-1/4 to 6-1/2 in. (13–16 cm)	100 Hz
3-1/2 to 5-1/4 in. (9–13 cm)	120 Hz
Under 3-1/2 in. (9 cm)	150 Hz

Continue with step 10 on page 46.

Note:



If the crossover frequency is set to a low value, and the program material doesn’t contain any sounds below that frequency, the subwoofer will not output much sound.

Double Bass

This setting is not set automatically by the Automatic Speaker Setup function (see page 38).

With the Double Bass function, you can boost bass output by feeding bass sounds from the front left and right channels to the subwoofer. This function can be set only if the Subwoofer setting in step 3 is set to Yes, and the Front setting in step 4 is set to Large.

In the speaker setup screen, you can choose how bass information is distributed to your speakers only if you have large front left and right speakers AND a subwoofer.

<p>10</p> 	<p>Use the Up and Down [▲]/[▼] buttons to select “h. Double Bass,” and then use the Left and Right [◀]/[▶] buttons to select:</p> <p>On: Double Bass function on (default). Front left and right bass also goes to the subwoofer simultaneously.</p> <p>Off: Double Bass function off.</p>
<p>11</p> 	<p>Press the [SETUP] button.</p> <p>The setup menu closes.</p>

Note:

This procedure can also be performed on the AV receiver by using its [SETUP] button, arrow buttons, and [ENTER] button.

Speaker Distance

This setting is set automatically by the Automatic Speaker Setup function (see page 38).

Here you can specify the distance from each speaker to the listening position so that the sound from each speaker arrives at the listener's ears as the sound designer intended.

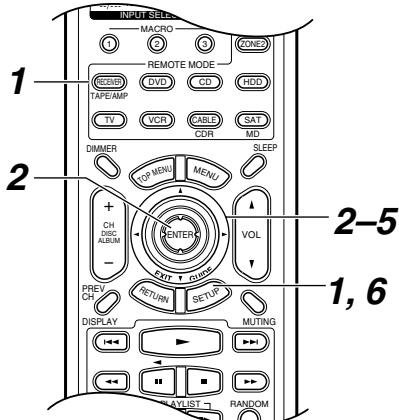

1 Press the [RECEIVER] button followed by the [SETUP] button. The main menu appears onscreen.



2 Use the Up and Down [▲]/[▼] buttons to select "2. Speaker Distance," and then press [ENTER]. The Speaker Distance menu appears.

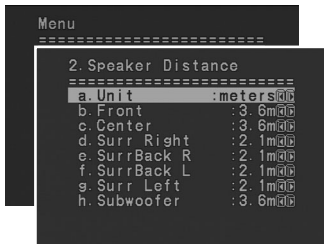

Note: Speakers that you set to No or None on the Speaker Configuration page (page 44) cannot be selected.

3 Use the Up and Down [▲]/[▼] buttons to select "a. Unit," and then use the Left and Right [◀]/[▶] buttons to select:



feet: Select if you want to enter distances in feet. Can be set from 1 to 30 feet in 1-foot steps.
meters: Select if you want to enter distances in meters. Can be set from 0.3 to 9 meters in 0.3-meter steps.

4 Use the Up and Down [▲]/[▼] buttons to select "b. Front," and then use the Left and Right [◀]/[▶] buttons to specify the distance.



Specify the distance from the front left speaker to your listening position.

5 Repeat step 4 for all speakers.

6 Press the [SETUP] button. The setup menu closes.



Notes:

- The Center and Subwoofer distances can be set up to 5 ft. (1.5 m) more or less than the Front distance. For example, if the Front distance is set to 20 ft. (6 m), the Center and Subwoofer distances can be set between 15 and 25 ft. (4.5 and 7.5 m). The Surr Right, Surr Left, and Surr Back distances can be set up to 5 ft. (1.5 m) more or 15 ft. (4.5 m) less than the Front distance. For example, if the Front distance is set to 20 ft. (6 m), the Surr Right, Surr Left, and Surr Back distances can be set between 5 and 25 ft. (1.5 and 7.5 m).
- This procedure can also be performed on the AV receiver by using its [SETUP] button, arrow buttons, and [ENTER] button.

Speaker Level Calibration

This setting is set automatically by the Automatic Speaker Setup function (see page 38).

Here you can adjust the level of each speaker with the built-in test tone so that the volume of each speaker is the same at the listening position.

Note:

The speakers cannot be calibrated while the output of the AV receiver is muted, while a pair of headphones is connected, or when using the multichannel input.

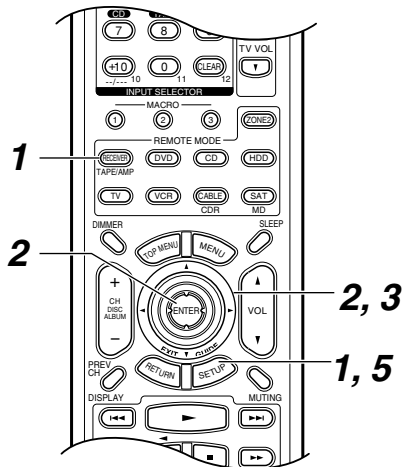

1 Press the [RECEIVER] button followed by the [SETUP] button. The main menu appears onscreen.

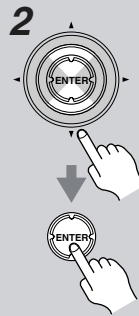

2 Use the Up and Down [▲]/[▼] buttons to select “3. Level Calibration,” and then press [ENTER].

The Level Calibration menu appears and the pink noise test tone is output by the front left speaker.

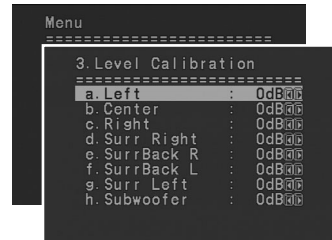

Note:

Speakers that you set to No or None on the Speaker Configuration page (page 44) cannot be selected.



3 Use the Up and Down [▲]/[▼] buttons to select each speaker, and use the Left and Right [◀]/[▶] buttons to set the volume.

The volume can be adjusted from -12 to +12 dB in 1 dB steps (-15 to +12 dB for the subwoofer).

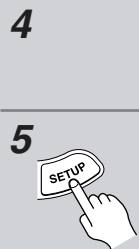

4 Repeat step 3 until the volume of the test tone from each speaker is the same.

5 Press the [SETUP] button. The setup menu closes.

Note:

This procedure can also be performed by using the remote controller. First press the [TEST TONE] button to output the test tone. Use the [LEVEL-] and [LEVEL+] buttons to set the volume, and use the [CH SEL] button to select the speakers.

Equalizer Setting

This setting is set automatically by the Automatic Speaker Setup function (see page 38).

Here you can adjust the EQ of individual speakers. To set the volume of individual speakers see page 48.

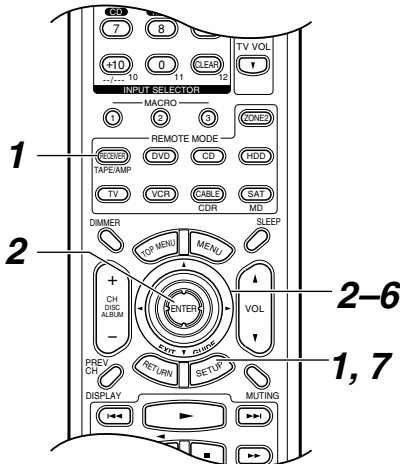

1 Press the [RECEIVER] button followed by the [SETUP] button. The main menu appears onscreen.

2 Use the Up and Down [▲]/[▼] buttons to select “6. Equalizer Settings,” and then press [ENTER]. The Equalizer Settings menu appears.

3 Use the Left and Right [◀]/[▶] buttons to select:

Off: Tone off, response flat.
Auto: The tone for each speaker is set automatically by the Automatic Speaker Setup function.
Manual: You can adjust the EQ of each speaker manually.

If you select Manual, continue with this procedure. If you select Off or Auto, go to step 7.

4 Use the Down [▼] button to select “Channel,” and then use the Left and Right [◀]/[▶] buttons to select a speaker.

```

Menu
=====
6. Equalizer Settings
-----
a. Use Settings:Manual
-----
b. Channel :Left
-----
c. 80Hz : 0dB
d. 250Hz : 0dB
e. 800Hz : 0dB
f. 2.5kHz : 0dB
g. 8kHz : 0dB
            
```

5 Use the Up and Down [▲]/[▼] buttons to select a frequency, and then use the Left and Right [◀]/[▶] buttons to adjust the level at that frequency.

The volume at each frequency can be adjusted from -6 to +6 dB in 1 dB steps.

Tip: Low frequencies (e.g., 80 Hz) affect bass sounds; high frequencies (e.g., 8 kHz) affect treble sounds.

6 Use the Up [▲] button to select “Channel,” and then use the Left and Right [◀]/[▶] buttons to select another speaker.

Repeat steps 5 and 6 for each speaker.

7 Press the [SETUP] button. The setup menu closes.

Note: This procedure can also be performed on the AV receiver by using its [SETUP] button, arrow buttons, and [ENTER] button.

Changing the Input Display

If you connect an **RI**-capable Onkyo MiniDisc recorder, CD recorder, or next generation HDD-compatible component to the TAPE IN/OUT or VIDEO 3 IN jacks, for **RI** to work properly, you must change this setting.

This setting can only be changed on the AV receiver.

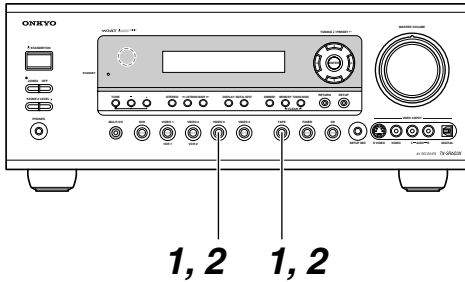

iPod photo: If you're using an iPod photo with the DS-A1 Remote Interactive Dock, connect the DS-A1 to the VIDEO 3 IN jacks.

<p>1</p> <p>TAPE</p> <p>VIDEO 3</p>	<p>Press the [TAPE] or [VIDEO 3] input selector button so that "TAPE" or "VIDEO 3" appears on the display.</p> <div style="border: 1px solid black; padding: 2px; margin: 5px 0; text-align: center;">TAPE</div> <div style="border: 1px solid black; padding: 2px; margin: 5px 0; text-align: center;">VIDEO 3</div>
<p>2</p> <p>TAPE</p> <p>VIDEO 3</p>	<p>Press and hold down the [TAPE] or [VIDEO 3] input selector button (about 3 seconds) to change the setting.</p> <p>Repeat this step to select MD, CDR, or HDD.</p> <p>For the TAPE input selector, the setting changes in this order:</p> <p style="text-align: center;">TAPE → MD → CDR → HDD</p> <p style="text-align: center;">↑</p> <p>For the VIDEO 3 input selector, the setting changes in this order:</p> <p style="text-align: center;">VIDEO 3 ↔ HDD</p>

Note:

HDD can be selected for the TAPE input selector or VIDEO 3 input selector, but not both at the same time.

Basic Operations

Selecting the Input Source

This section explains how to select the input source (i.e., the AV component that you want to listen to or watch).

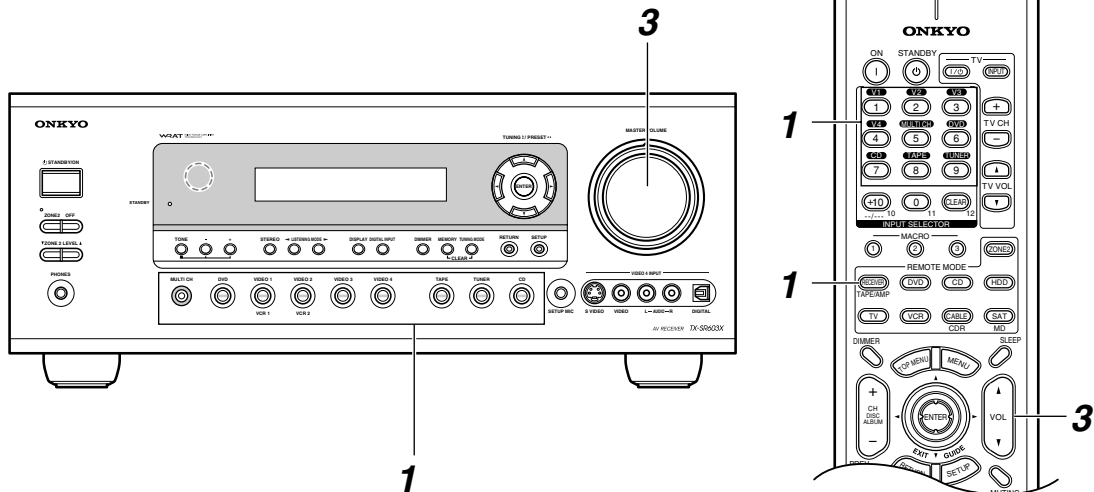

<p>1</p> <p>AV receiver</p> <p>Remote controller</p> <p>or</p>	<p>Use the AV receiver's input selector buttons to select the input source.</p> <p>To select the input source with the remote controller, press the [RECEPTION] button, and then use the INPUT SELECTOR buttons.</p> <p>On the remote controller, the [V1], [V2], [V3], and [V4] buttons select the VIDEO 1, VIDEO 2, VIDEO 3, and VIDEO 4 input sources, respectively.</p>
<p>2</p>	<p>Start playback on the source component.</p> <p>When you select DVD or another video component, on your TV, you'll need to select the video input that's connected to the AV receiver's MONITOR OUT.</p> <p>On some DVD players, you may need to turn on the digital audio output.</p>
<p>3</p> <p>AV receiver</p> <p>Remote controller</p> <p>or</p>	<p>To adjust the volume, use the MASTER VOLUME control, or the remote controller's [VOL] button.</p> <p>The volume can be set to MIN, 1 through 99, or MAX.</p> <p>The AV receiver is designed for home theater enjoyment. It has a wide volume range, allowing precise adjustment.</p>

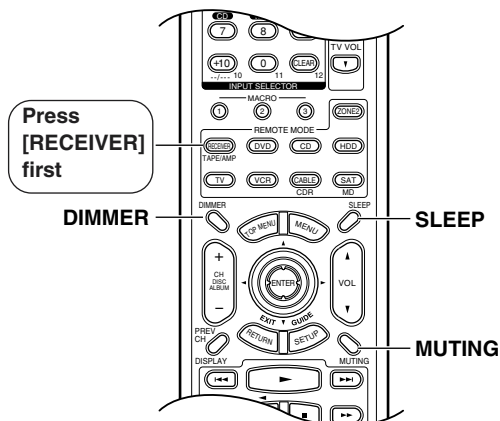

Setting the Display Brightness

You can adjust the brightness of the display.

Press the [RECEIVER] button, and then press the [DIMMER] button repeatedly to select:

- Normal+VOLUME light on.
- Normal+VOLUME light off.
- Dim+VOLUME light off.
- Dimmer+VOLUME light off.

Muting the AV Receiver

You can temporarily mute the output of the AV receiver.

Press the [RECEIVER] button, and then press the [MUTING] button.

The output is muted and the MUTING indicator flashes on the display, as shown.

To unmute the AV receiver, press the [MUTING] button again, or adjust the volume.

The Mute function is cancelled when the AV receiver is set to Standby.

Using the Sleep Timer

With the sleep timer, you can set the AV receiver to turn off automatically after a specified period.

Press the [RECEIVER] button, and then press the [SLEEP] button repeatedly to select the required sleep time.

The sleep time can be set from 90 to 10 minutes in 10 minute steps.

The SLEEP indicator appears on the display when the sleep timer has been set. The specified sleep time appears on the display for about five seconds, then the previous display reappears.

If you need to cancel the sleep timer, press the [SLEEP] button repeatedly until the SLEEP indicator disappears.

To check the time remaining until the AV receiver sleeps, press the [SLEEP] button. Note that if you press the [SLEEP] button while the sleep time is being displayed, you'll shorten the sleep time by 10 minutes.

Using Headphones

You can connect a pair of stereo headphones (1/4-inch phone plug) to the AV receiver's PHONES jack for private listening, as shown.

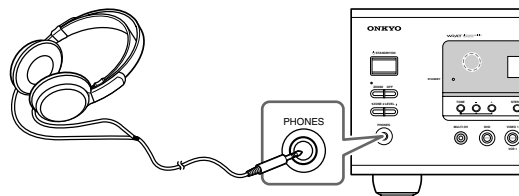

Notes:

- Always turn down the volume before connecting your headphones.
- The speakers are turned off while the headphones plug is inserted in the PHONES jack (Zone 2 speakers are not turned off).
- When you connect a pair of headphones, the listening mode is set to Stereo, unless it's already set to Stereo, Mono or Direct.
- Only the Stereo, Direct and Mono listening modes can be used with headphones (the listening modes available also depends on the currently selected input source).
- When the multichannel input is used, only the front left and right audio can be heard in the headphones.
- To adjust the headphone level, press the [CH SEL] button on the remote controller, and then press the [LEVEL +]/[LEVEL -] buttons. You can adjust the level between -12 dB and +12 dB.

Displaying Source Information

You can display various information about the current input source as follows.

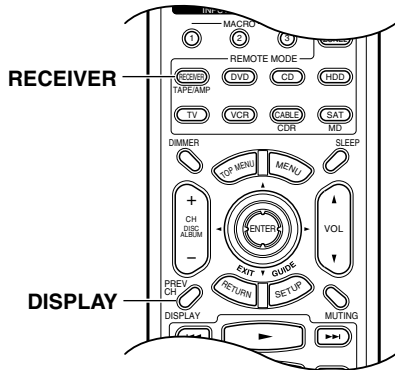

- B: The number of surround channels (2 means surround left and surround right). If there's surround back channel information, this will be 3.
- C: LFE channel for subwoofer (1 means yes).



Note:

This procedure can also be performed on the AV receiver by using its [DISPLAY] button.

The following information can typically be displayed for input sources.

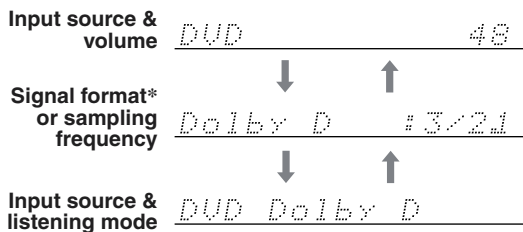

* If the input signal is analog, no format information is displayed. If the input signal is PCM, the sampling frequency is displayed. If the input signal is digital but not PCM, the signal format is displayed. Information is displayed for about three seconds, then the previously displayed information reappears.

Interpreting Surround Channel Values

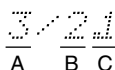

A: The number of front channels (3 means front left, front right, and center).

Using the Tuner

With the built-in tuner you can enjoy AM and FM radio stations. You can store your favorite stations as presets for quick selection.

Listening to the Radio

1



Use the [TUNER] input selector button to select either AM or FM. In this example, FM has been selected. Each time you press the [TUNER] button, the input source changes between AM and FM.

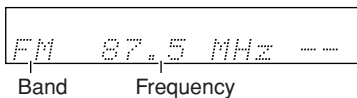

(Actual display depends on country)

Tuning into Radio Stations

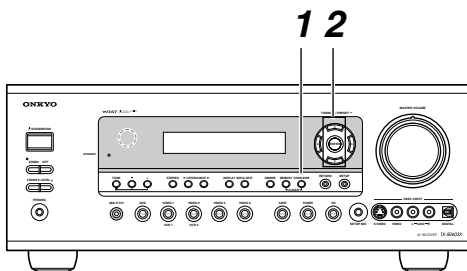

Auto Tuning Mode

1



Press the [TUNING MODE] button so that the AUTO indicator appears on the display.

2



Press the TUNING Up or Down [▲]/[▼] button. Searching stops when a station is found.

When tuned into a station, the TUNED indicator appears. When tuned into a stereo FM station, the FM STEREO indicator appears on the display, as shown.

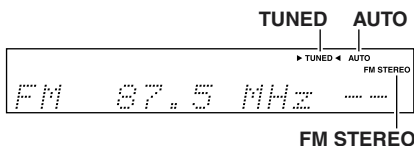

Manual Tuning Mode

1



Press the [TUNING MODE] button so that the AUTO indicator disappears from the display.

2



Press and hold the TUNING Up or Down [▲]/[▼] button. The frequency stops changing when you release the button. Press the buttons repeatedly to change the frequency one step at a time.

The North American model changes FM frequency in 0.2 MHz steps, 10 kHz steps for AM. For other models it's 0.05 MHz steps for FM and 9 kHz steps for AM. In Manual Tuning mode, FM stations will be in mono.

Tuning into weak FM stereo stations

If the signal from a stereo FM station is weak, it may be impossible to get good reception. In this case, switch to Manual Tuning mode and listen to the station in mono.

Displaying Radio Information

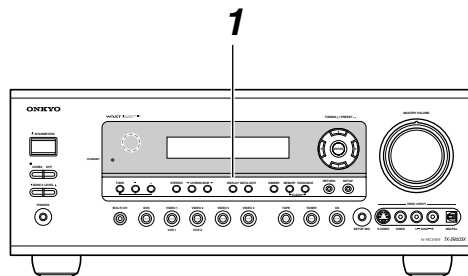

1



Press the [DISPLAY] button repeatedly to cycle through the available information.

Band, frequency & preset #

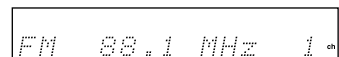

Listening mode

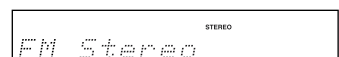

Listening to XM Satellite Radio®

What's XM Satellite Radio?

There is a world beyond AM and FM. It is XM Satellite Radio. XM offers more than 150 digital channels of audio entertainment, including 100% commercial-free music channels, in the top markets in the U.S.

Note: An XM Connect-and-Play™ antenna and monthly subscription are required to receive XM Satellite Radio. Visit www.xmradio.com for details.

Note:

Hardware and required basic monthly subscription sold separately. Premium Channels available at additional monthly cost. Installation costs and other fees and taxes, including a one-time activation fee may apply. Subscription fee is consumer only. All fees and programming subject to change. Channels with frequent explicit language are indicated with an XL. Channel blocking is available for XM radio receivers by calling 1-800-XMRADIO. Subscriptions subject to Customer Agreement available at xmradio.com. Only available in the 48 contiguous United States.

A warning against reverse engineering:

It is prohibited to copy, decompile, disassemble, reverse engineer, or manipulate any technology incorporated in receivers compatible with the XM Satellite Radio system. Furthermore, the AMBE® voice compression software included in this product is protected by intellectual property rights including patent rights, copyrights, and trade secrets of Digital Voice Systems, Inc. The user of this or any other software contained in an XM Radio is explicitly prohibited from attempting to copy, decompile, reverse engineer, or disassemble the object code, or in any other way convert the object code into human-readable form. The software is licensed solely for use within this product.

Connecting the XM Antenna

The XM antenna is sold separately. You can purchase the XM Connect-and-Play antenna from the XM Web site at: <http://www.xmradio.com>

- 1 Connect the Connect-and-Play antenna to the XM antenna jack on the rear panel.**

XM antenna jack

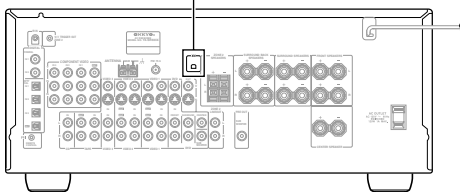

- 2 Put the XM antenna by a southerly facing window, with nothing obstructing its path to the sky.**

Signing Up for XM Satellite Radio

Before you can use XM Satellite Radio, you must first sign up for an account. You'll need a major credit card and your XM Satellite Radio ID, which you can get from the AV receiver, as explained below or from the Connect-and-Play package and itself.

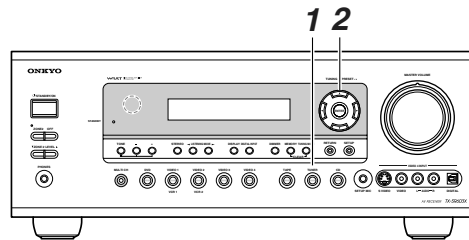

- 1 Press the [TUNER] input selector button repeatedly to select XM.**



If "CHECK ANTENNA" appears on the display, make sure the XM antenna is connected properly.

- 2 Use the TUNING Up and Down [▲]/[▼] buttons to select channel 0.**



Your XM Satellite Radio ID number is displayed. Write it below.

ID _____

- 3 To sign up, go to: <http://activate.xmradio.com> Or call: 1-800-967-2346.**

Notes:

- Channel 0 cannot be selected in Category Search mode. You must select Channel Search mode (see page 56).
- The following letters are not used in XM Satellite Radio IDs: I, O, S, F.

Selecting XM Radio Channels

There are two modes for selecting XM radio channels: **Channel Search mode**, which allows you to select any channel.

Category Search mode, which allows you to select channels by category.

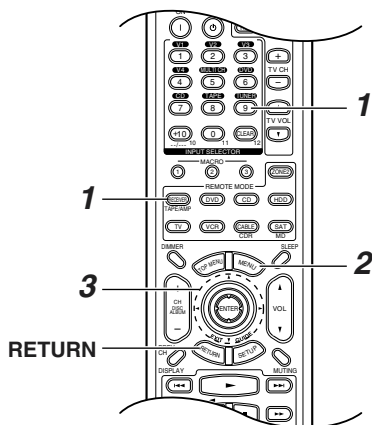

■ Channel Search Mode

<p>1</p>	<p>Press the [RECEIVER] REMOTE MODE button, and then press the [TUNER] INPUT SELECTOR button repeatedly to select XM.</p> <p>If “CHECK ANTENNA” appears on the display, make sure the XM antenna is connected properly.</p>
<p>2</p>	<p>Press the [MENU] button to select “Channel Search” mode.</p> <div style="border: 1px solid black; padding: 5px; text-align: center;">ChannelSearch</div>
<p>3</p>	<p>Use the Up and Down [▲]/[▼] buttons to select a channel.</p> <div style="border: 1px solid black; padding: 5px; text-align: center;"> 050 The Loft </div> <p style="text-align: center;">Channel number Channel name</p> <p>You can also use the Left and Right [◀]/[▶] buttons to select a category.</p>

Note:

Channels cannot be selected while the ►◀ indicator is flashing, as tuning is in progress.

■ Category Search Mode

<p>1</p>	<p>Press the [RECEIVER] REMOTE MODE button, and then press the [TUNER] INPUT SELECTOR button repeatedly to select XM.</p> <p>If “CHECK ANTENNA” appears on the display, make sure the XM antenna is connected properly.</p>
<p>2</p>	<p>Press the [MENU] button to select “Category Search” mode.</p> <div style="border: 1px solid black; padding: 5px; text-align: center;">CategorySearch</div>
<p>3</p>	<p>Use the Left and Right [◀]/[▶] buttons to select a category, and use the Up and Down [▲]/[▼] buttons to select a channel in that category.</p>

Note:

Channels cannot be selected while the ►◀ indicator is flashing, as tuning is in progress.

■ Selecting the Previous Channel

To listen to the previously selected XM channel.

<p>1</p>	<p>Press the [RECEIVER] REMOTE MODE button, followed by the [RETURN] button.</p>
-----------------	---

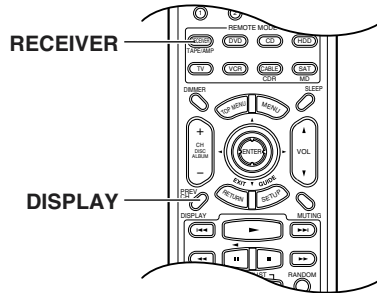
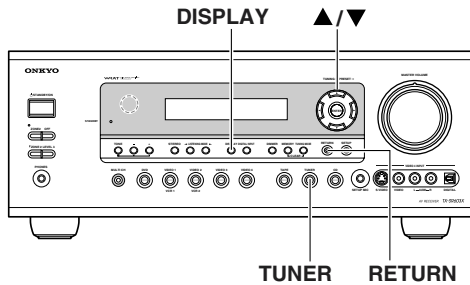

Selecting XM Channels from the Front Panel:

<p>1</p>	<p>Press the [TUNER] input selector button repeatedly to select XM. If “CHECK ANTENNA” appears on the display, make sure the XM antenna is connected properly.</p>
<p>2</p>	<p>Use the TUNING Up and Down [▲]/[▼] buttons to select a channel. In Channel Search mode, you can select any channel. In Category Search mode, you can only select channels from the currently selected category.</p>

Displaying XM Radio Information

<p>1</p>	<p>On the AV receiver, press the [DISPLAY] button repeatedly to cycle through the available information.</p>
<p>Remote controller</p>	<p>On the remote controller, press the [RECEIVER] REMOTE MODE button, and then press the [DISPLAY] button repeatedly.</p>

The following information can be displayed:

Channel name	XM The Loft
Channel number & preset number	XM 050 5
Category	CAT >Rock
Artist	NAME>Coldplay
Song title	TITL>Clocks
Listening mode	XM Stereo

Note:
If the category, artist, or song title is not available, “- - -” will be displayed instead.

■ Displaying XM Information on Your TV

When you select a different XM channel, or the artist or song title changes, the following information is displayed on your TV for 5 seconds.

XM	[Category name]	
	[Channel name]	[Ch. No]
	[Artist name / Song Title]	

Tip:
You can display this information at anytime by pressing the [DISPLAY] button.

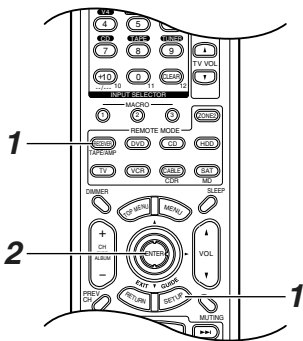

Positioning the XM Antenna

You can check the signal strength of the XM radio signal and adjust the position of the XM antenna accordingly.

1 Press the [RECEIVER] button followed by the [SETUP] button. The main menu appears onscreen.

2 Use the Up and Down [▲]/[▼] buttons to select “5. XM Setup,” and then press [ENTER]. The XM Setup menu appears. Adjust the position of the XM antenna so that the signal strength is at least 70 %.

```

Menu
=====
5. XM Setup
=====
a. Antenna Aiming

Signal Quality 80%

[#####]
    
```

* This line indicates the signal strength of 70 %.
The signal level range is 0 % to 100 %.

Note:

If the signal level is 0 %, make sure that the XM antenna is connected properly.

XM Radio Messages

The following messages may appear while using XM radio.

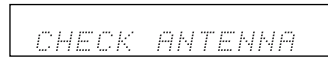

The XM antenna is not connected properly. Check the antenna.



The XM user encryption code is being updated. Please wait.

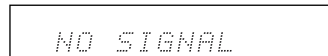

The signal is too weak. Check the antenna connection and reposition it for the best reception.

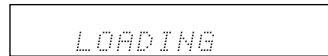

The AV receiver is tuning or decoding audio or text data. Please wait.

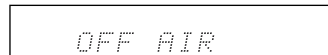

The XM channel you selected is not currently broadcasting. Select another channel.

Presetting AM/FM Stations & XM Channels

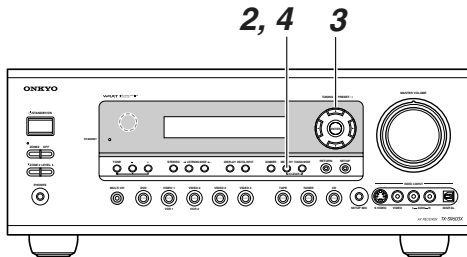

You can store a combination of up to 40 of your favorite AM/FM radio stations and XM channels as presets.

- 1** Tune into the AM/FM station or XM channel that you want to store as a preset.
- 2** Press the [MEMORY] button. The MEMORY indicator appears and the preset number flashes.
- 3** While the MEMORY indicator is displayed (about 8 seconds), use the PRESET [◀]/[▶] buttons to select a preset from 1 through 40.
- 4** Press the [MEMORY] button again to store the station or channel. The station or channel is stored and the preset number stops flashing. Repeat this procedure for all of your favorite AM/FM radio stations and XM channels.

Selecting Presets

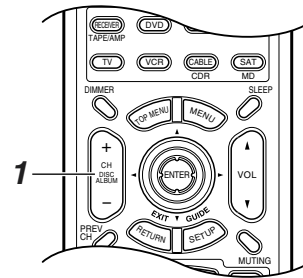
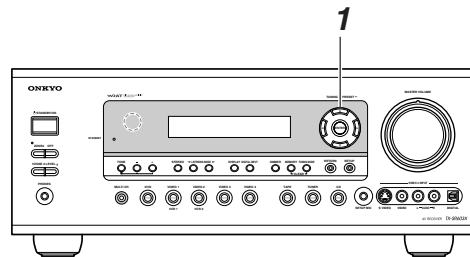

- 1** To select a preset, use the PRESET [◀]/[▶] buttons, or the remote controller's CH [+/-] button.

Deleting Presets

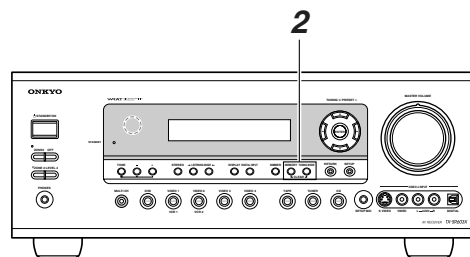

- 1** Select the preset that you want to delete. See the previous section.
- 2** While holding down the [MEMORY] button, press the [TUNING MODE] button. The preset is deleted and its number disappears from the display.

Selecting Listening Modes

See “About the Listening Modes” on page 62 for detailed information about the listening modes.

- The Dolby Digital and DTS listening modes can only be selected if your DVD player is connected to the AV receiver with a digital audio connection (coaxial or optical).
- Listening mode availability depends on the format of the current input signal.

Selecting on the AV receiver

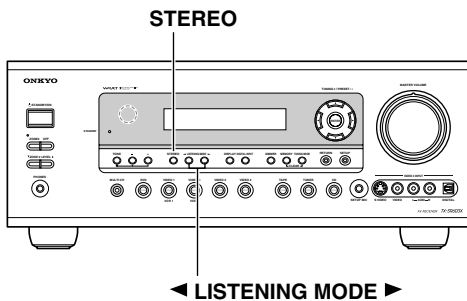

■ [STEREO] button

This button selects the Stereo listening mode.

■ LISTENING MODE [◀] [▶] buttons

These buttons select all the listening modes that can be used with the current input source.

Modes can be selected in the following order, depending on the input signal format:

Direct → Stereo → Mono → Surround (e.g., PLIIx, Neo:6, Dolby D EX, DTS/DTS 96/24, DTS-ES, and so on) → Onkyo original DSP

Selecting with the Remote Controller

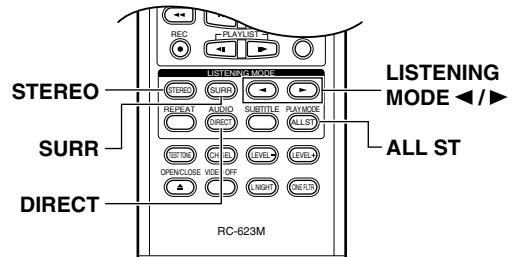

■ [SURR] button

This button selects the Dolby Digital, Pro Logic IIx, Neo:6, DTS, and other listening modes.

■ [All ST] button

This button selects the All Ch Stereo listening mode.

■ [STEREO] button

This button selects the Stereo listening mode.

■ [DIRECT] button

This button selects the Direct listening mode.

■ LISTENING MODE [◀]/[▶] buttons

Pressing these buttons repeatedly cycles through all of the listening modes that can be used with the current input source.

Basic Operations—Continued

The following table lists all the listening modes and shows which modes can be selected for each input signal format.

Input signal format	Analog, PCM*1	Dolby D				DTS/DTS 96/24*2				Multich
		3/2, 2/2	2/0	1/0, 1+1	Other	3/2, 2/2	2/0	1/0, 1+1	Other	
Source	CD, TV, LD, VHS, MD, turntable, radio, cassette, DTV, etc.	DVD, DTV, etc.				DVD, LD, CD, etc.				DVD
Listening mode										
Direct	<input type="radio"/>	<input type="radio"/>	<input type="radio"/>	<input type="radio"/>	<input type="radio"/>	<input type="radio"/>	<input type="radio"/>	<input type="radio"/>	<input type="radio"/>	<input type="radio"/>
Stereo	<input type="radio"/>	<input type="radio"/>	<input type="radio"/>	<input type="radio"/>	<input type="radio"/>	<input type="radio"/>	<input type="radio"/>	<input type="radio"/>	<input type="radio"/>	<input type="radio"/>
Mono	<input type="radio"/>	<input type="radio"/>	<input type="radio"/>	<input type="radio"/>	<input type="radio"/>	<input type="radio"/>	<input type="radio"/>	<input type="radio"/>	<input type="radio"/>	<input type="radio"/>
PLIIx Movie/Music/Game *3	<input type="radio"/>		<input type="radio"/>				<input type="radio"/>			
Neo:6 Cinema	<input type="radio"/>		<input type="radio"/>				<input type="radio"/>			
Neo:6 Music *4	<input type="radio"/>		<input type="radio"/>				<input type="radio"/>			
Dolby D		<input type="radio"/>			<input type="radio"/>					
Dolby D EX *5		<input type="radio"/>								
Dolby D+PLIIx Movie *6		<input type="radio"/>								
Dolby D+PLIIx Music *5		<input type="radio"/>								
DTS, DTS 96/24						<input type="radio"/>			<input type="radio"/>	<input type="radio"/> *7
DTS+Neo:6 *5						<input type="radio"/>				
DTS+Dolby EX *5						<input type="radio"/>				
DTS+PLIIx Movie *6/Music *5						<input type="radio"/>				
DTS-ES Discrete *5										Discrete
DTS-ES Matrix *5										Matrix
Multich										<input type="radio"/>
Mono Movie										
Orchestra										
Unplugged	<input type="radio"/>	<input type="radio"/>	<input type="radio"/>	<input type="radio"/>	<input type="radio"/>	<input type="radio"/>	<input type="radio"/>	<input type="radio"/>	<input type="radio"/>	<input type="radio"/>
Studio-Mix										
TV Logic										
All Ch Stereo	<input type="radio"/>	<input type="radio"/>	<input type="radio"/>	<input type="radio"/>	<input type="radio"/>	<input type="radio"/>	<input type="radio"/>	<input type="radio"/>	<input type="radio"/>	<input type="radio"/>
Full Mono	<input type="radio"/>	<input type="radio"/>	<input type="radio"/>	<input type="radio"/>	<input type="radio"/>	<input type="radio"/>	<input type="radio"/>	<input type="radio"/>	<input type="radio"/>	<input type="radio"/>

1. In the Direct listening modes, PCM signals at 32 kHz, 44.1 kHz, and 48 kHz are processed at 64 kHz, 88.2 kHz, and 96 kHz, respectively. 96 kHz signals are processed at 48 kHz for all listening modes other than Direct and Stereo.
2. In the Direct, Stereo, and DTS 96/24 listening modes, signals are processed as DTS 96/24. Everything else is processed as DTS.
3. If the SurrBack parameter is set to "None," or the Zone 2 speakers are being used, PLII is used.
4. Available only when Surround speakers are connected.
5. Cannot be selected if the SurrBack parameter is set to "None" or the Zone 2 speakers are being used.
6. Cannot select if the SurrBack ch setting is not set to "2ch," or the Zone 2 speakers are being used.
7. If the SurrBack setting is set to "None," or the Zone 2 speakers are being used, DTS is used.

About the Listening Modes

With its built-in surround sound decoders and DSP programs, the AV receiver can transform your home listening room into a movie theater or concert hall.

If you connect two surround back speakers (i.e., left and right), both will be used for 6.1-channel surround playback.

The AV receiver's surround indicators show which speakers are active in each listening mode.

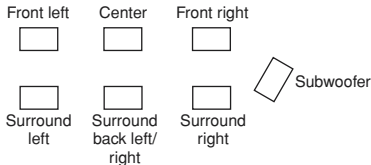

Direct

The selected input source is output directly with minimal processing for a pure sound.

Stereo

The selected input source is processed as a stereo signal and output by the front left and right speakers and the subwoofer.

Mono

Use this mode when watching an old movie with a mono soundtrack, or to select multilingual soundtracks recorded in the left and right channels of some movies. It can also be used when playing a DVD or other source with multiplexed audio, such as a karaoke DVD.

Dolby Pro Logic II Movie

Use this mode with DVDs and videos that bear the Dolby Surround logo or TV programs that feature Dolby Surround. You can also use this mode with stereo movies or TV programs and the AV receiver will create a 5.1 surround mix from the 2-channel stereo.

Dolby Pro Logic II Music

Use this mode to add 5.1 surround to stereo sources such as music CDs and DVDs.

Dolby Pro Logic IIx

If you've connected surround back speakers to the AV receiver, Dolby Pro Logic IIx allows you to enjoy 7.1-channel playback from 2-channel or 5.1-channel music or movies. Dolby Pro Logic IIx provides a well defined, natural multichannel surround sound experience, putting the listener in a seamless envelope of sound. The added drama and natural sound enhance the listening experience with CDs, movies, and games.

Dolby Pro Logic IIx has three modes of operation: Movie mode for movies, Music mode for listening to music, and Game mode for use with game consoles with 2-channel stereo outputs.

Dolby Digital

With this format you can experience the same superb sound that you get at a movie theater or concert hall. Use this mode with DVDs that bear the Dolby Digital logo.



Dolby Digital EX

With an added surround-back channel, this 6.1-channel format offers a heightened sense of space, for added realism with moving sounds, such as those that rotate 360 degrees or pass overhead. Dolby Digital EX material can also be played on conventional 5.1-channel systems, in which case the surround-back channel audio is split between the surround left and right channels. Use this mode with DVDs that have a 5.1-channel soundtrack and bear the Dolby Digital logo.



DTS

This digital surround format offers a surround sound experience with exceptional fidelity. It uses compressed digital audio data, with six discrete channels (5.1), and the ability to handle large amounts of audio data while remaining faithful to the original. DTS provides very high-quality sound. You'll need a DTS compatible DVD player in order to enjoy DTS material. Use this mode with DVDs, LDs, or CDs that bear the DTS logo.



DTS 96/24

This mode provides higher audio quality. Use it with CDs, DVDs, and LDs that bear the DTS 96/24 logo.



DTS-ES Discrete

This is DTS with an added surround back channel for 6.1 surround sound. Use it with program material recorded in DTS 6.1 format. With the additional surround back channel, this format offers 6.1 fully independent digital channels, providing a realistic sense of movement and space. Use it with program material recorded in DTS 6.1, such as CDs, DVDs, or LDs that bear the DTS-ES logo.



DTS-ES Matrix

This is DTS with an added surround back channel for 6.1 surround sound. Use it to provide 6.1-channel surround playback with program material recorded in DTS 5.1 format. Since DTS 5.1 program material contains surround back channel information, all channels can be reconstructed for 6.1-channel playback. Use this mode with CDs, DVDs, or LDs that bear the DTS-ES or DTS logo.



Neo:6

This mode provides 6.1-channel playback from 2-channel sources. It offers six full-bandwidth channels with excellent separation. There are two modes of operation: Cinema mode for movies, and Music mode for listening to music.

Cinema mode simulates the realistic sense of movement that you get with 6.1-channel surround sound sources. Use this mode with videos, DVDs, and TV programs that feature stereo sound.

Music mode uses the surround channels to simulate a natural sound field that cannot be produced with conventional stereo. Use this mode with stereo material such as music CDs.

Onkyo Original DSP Modes

Orchestra

Suitable for classical or operatic music. The surround channels are emphasized in order to widen the stereo image. In addition, it simulates the natural reverberation of a large hall.

Unplugged

Suitable for acoustic instrument sounds, vocals, and jazz music. By emphasizing the front stereo image, it simulates the stage-front experience.

Studio-Mix

Suitable for rock and pop music. Listening to music in this mode creates a lively sound field with a powerful acoustic image, like being at a club or rock concert.

TV Logic

Adds realistic acoustics to TV programs produced in a TV studio. In addition, it adds surround effects to the entire sound and adds clarity to voices.

Mono Movie

This mode is suitable for use with old movies and other mono sound sources. The center speaker outputs the sound as it is, while reverb is applied to the sound output by the other speakers, giving presence to even mono material.

All Ch Stereo

Ideal for background music. The front, surround, and surround back channels create a stereo image that fills the entire listening area.

Full Mono

In this mode, all speakers output mono audio, so the music sounds the same regardless of where you are.

Advanced Operations

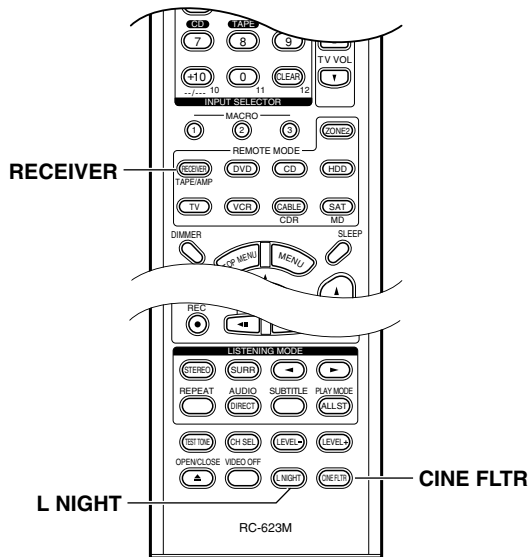

Using the CinemaFILTER

With the CinemaFILTER, you can soften overly bright movie soundtracks, which are typically mixed for reproduction in a movie theater.

CinemaFILTER can be used with the following listening modes: Dolby Digital, Dolby Digital EX, Dolby Pro Logic IIx Movie, Dolby Pro Logic II Movie, DTS, DTS-ES, DTS Neo:6 Cinema, DTS 96/24, DTS+Neo:6, and DTS+Dolby EX.

1



Press the [RECEIVER] button, and then press the [CINE FLTR] button repeatedly to select:

- On:** CinemaFILTER on.
- Off:** CinemaFILTER off.

Using the Late Night Function (Dolby Digital only)

With the Late Night function, you can reduce the dynamic range of Dolby Digital material so that you can still hear quiet parts even when listening at low volume levels—ideal for watching movies late at night when you don't want to disturb anyone.

1



Press the [RECEIVER] button, and then press the [L NIGHT] button repeatedly to select:

- Off:** Late Night function off.
- Low:** Small reduction in dynamic range.
- High:** Big reduction in dynamic range.

Notes:

- The effect of the Late Night function depends on the Dolby Digital material that you are playing, and with some material there will be little or no effect.
- The Late Night function is set to Off when the AV receiver is set to Standby.

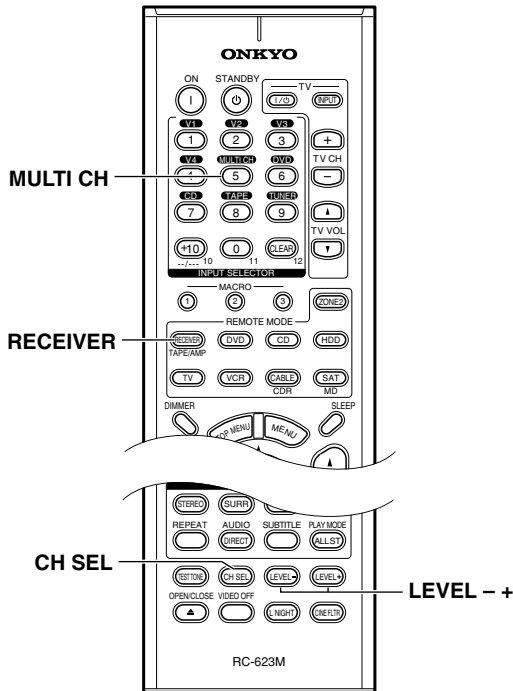

Using the DVD Analog Multichannel Input

The DVD analog multichannel input is for connecting components with a 5.1-channel analog audio output, such as a DVD player or MPEG decoder.

See “Using a Multichannel Connection” on page 28 for connection information.

1 Press the [RECEIVER] button followed by the [MULTI CH] button so that the MULTI CH indicator appears on the display.

The diagram illustrates the process: a hand presses the [RECEIVER] button, then the [MULTI CH] button. Below, a display shows 'DVD' and 'MULTI CH'.

Note:
To use the bass and treble functions with the DVD analog multichannel input, select the Multich listening mode first.

Adjusting Individual Speaker Levels

You can adjust the level of individual speakers during playback. These adjustments are temporary and will be cancelled when the AV receiver is set to Standby.

1 Press the [RECEIVER] button, use the [CH SEL] button to select each speaker, and use the [LEVEL-] and [LEVEL+] buttons to adjust the volume.

Speakers are selected in the following order: Front Left → Center → Front Right → Surr Right → Surr Back Right → Surr Back Left → Surr Left → Subwoofer.

You can adjust the volume of each speaker from -12 dB to +12 dB (-15 dB to +12 dB for the subwoofer). The name of the currently selected speaker and its volume appear on the display, as shown.

The diagram illustrates the process: a hand presses the [RECEIVER] button, then the [CH SEL] button, then the [LEVEL-] and [LEVEL+] buttons. Below, a display shows 'Left' and '0dB'.



Notes:

- You cannot use this function while the AV receiver is muted.
- Speakers that are set to No or None in the Speaker Configuration cannot be adjusted.

Adjusting Individual Speaker Levels

You can adjust the level of individual speakers while using the DVD analog multichannel input.

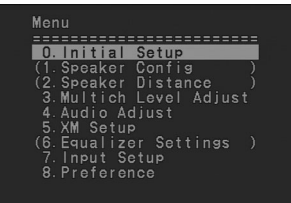
Adjusting with onscreen setup menus:

<p>1</p> 	<p>Press the [RECEIVER] button followed by the [SETUP] button. The main menu appears onscreen.</p> 
<p>2</p> 	<p>Use the Up and Down [▲]/[▼] buttons to select “3. Multich Level Adjust,” and then press [ENTER]. The Multich Level Adjust menu appears.</p>
<p>3</p> 	<p>Use the Up and Down [▲]/[▼] buttons to select each speaker, and use the Left and Right [◀]/[▶] buttons to set the volume. The volume can be adjusted from –12 to +12 dB in 1 dB steps (–30 to +12 dB for the subwoofer).</p>

Adjusting with the remote controller:

<p>1</p> 	<p>Use the remote controller’s [CH SEL] button to select each speaker, and then use the [LEVEL–] and [LEVEL+] buttons to adjust the volume. The level can be adjusted from –12 to +12 dB (–30 to +12 dB for the subwoofer).</p>
---	--

Notes:

- These speaker level settings are completely independent of those explained on pages 48, 65.
- While the DVD analog multichannel input is selected, you can only select the Direct or Multich listening mode. If you select the DVD analog multichannel input while using another listening mode, that listening mode will be cancelled.

- While the DVD analog multichannel input is selected, the Automatic Speaker Setup on page 38 and Speaker Configuration settings on page 44 are ignored, and signals from the multichannel input are fed to the front left, front right, center, surround left, and surround right speakers, and subwoofer regardless of those settings.

Recording

This section explains how to record the current input source, how to record one input source while enjoying another, and how to dub audio onto your video recordings.

Unless you have the full consent of the copyright holder, copyright laws prohibit using your recordings for anything other than personal enjoyment!

Notes:

- The surround sound and DSP listening modes cannot be recorded.
- Copy-protected DVDs cannot be recorded.
- You cannot record from the DVD analog multichannel input.
- Various restrictions apply to digital recording. Refer to the manuals supplied with your digital recording equipment for more details.
- Digital input signals are output by only the digital outputs, and analog input signals are output by only the analog outputs. There is no internal conversion from digital to analog or vice versa.
- DTS signals will be recorded as noise, so don’t attempt analog recording of DTS CDs or LDs.

AV Recording

You can record AV input sources to an AV recording component (VCR, etc.) connected to the VIDEO 1 OUT, VIDEO 2 OUT, or TAPE OUT. See pages 26–36 for information on connecting components.

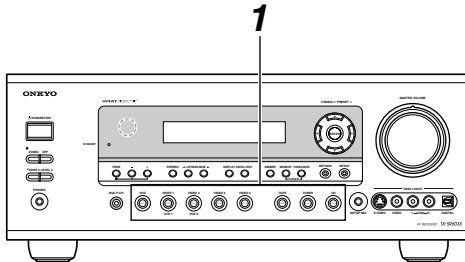

1

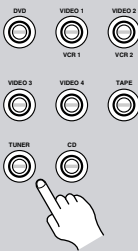

Use the input selector buttons to select the AV component that you want to record.

Audio signals from the selected input source are output by the VIDEO 1 OUT, VIDEO 2 OUT, and TAPE OUT only.

You can watch the source while recording, and the AV receiver's VOLUME control has no effect on recording.

2

Start recording on the AV component connected to the VIDEO 1 OUT, VIDEO 2 OUT, or TAPE OUT.

3

Start playback on the source AV component.

If you select another input source during recording, that input source will be recorded.

Recording Separate AV Sources

Here you can record audio and video from completely separate sources, allowing you to overdub audio onto your video recordings. This function takes advantage of the fact that when an audio-only input source (i.e., TAPE, TUNER, or CD) is selected, the video input source remains unchanged.

In the following example, audio from the CD player connected to the CD IN, and video from the camcorder connected to the VIDEO 4 INPUT VIDEO jack are recorded by the VCR connected to the VIDEO 1 OUT jacks.

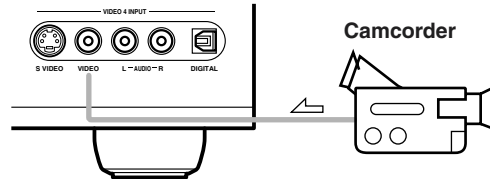

↙ : video signal
↘ : audio signal

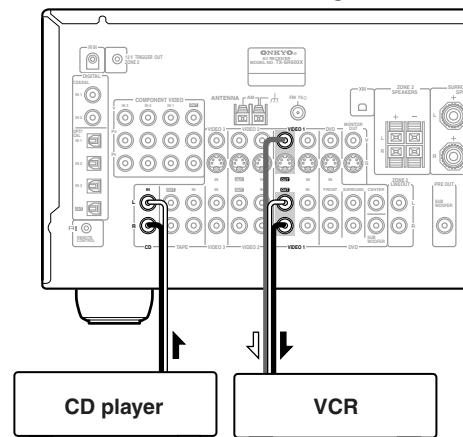

1

Prepare the camcorder and CD player for playback.

2

Prepare the VCR for recording.

3

Press the [VIDEO 4] input selector button.

4

Press the [CD] input selector button.

This selects the CD player as the audio source, but leaves the camcorder as the video source.

5

Start recording on the VCR and start playback on the camcorder and CD player.

The video from the camcorder and the audio from the CD player are recorded by the VCR.

Advanced Setup

Adjusting the Bass & Treble

You can adjust the bass and treble for the front speakers, except when the Direct listening mode is selected.

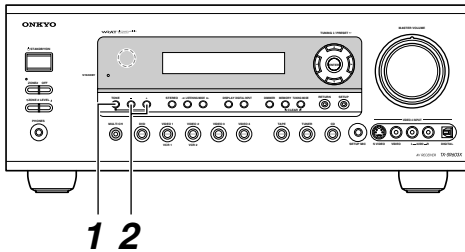

1 Press the [TONE] button repeatedly to select either Bass or Treble.



2 Use the TONE [-]/[+] buttons to adjust.

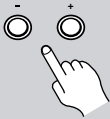

■ Bass

You can boost or cut low-frequency sounds output by the front speakers from -10 dB to +10 dB in 2 dB steps.

■ Treble

You can boost or cut high-frequency sounds output by the front speakers from -10 dB to +10 dB in 2 dB steps.

Audio Adjust Functions

Here you can set listening mode-related settings and functions.

1 Press the [RECEIVER] button followed by the [SETUP] button. The main menu appears onscreen.



2 Use the Up and Down [▲]/[▼] buttons to select "4. Audio Adjust," and then press [ENTER]. The Audio Adjust menu appears.

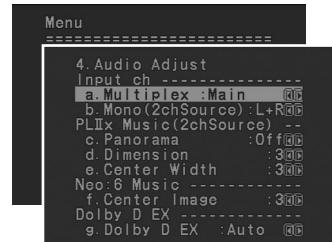

3 Use the Up and Down [▲]/[▼] buttons to select the settings, and use the Left and Right [◀]/[▶] buttons to set them. The settings are explained on page 69.

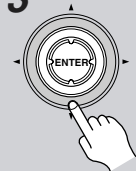

4 When you've finished, press the [SETUP] button. The setup menu closes.



Note:

This procedure can also be performed on the AV receiver by using its [SETUP] button, arrow buttons, and [ENTER] button.

The Audio Adjust functions are explained below.

Input Channel Settings

■ Multiplex

This setting determines which channel is output from a stereo multiplex source. Use it to select audio channels or languages with multiplex sources, multilingual TV broadcasts, and so on.

Main: The main channel is output (default).

Sub: The sub channel is output.

Main/Sub: Both the main and sub channels are output.

■ Mono (2chSource)

This setting specifies the channel to be used for playing any 2-channel digital source such as Dolby Digital, or 2-channel analog/PCM source in the Mono listening mode.

L+R: Both the left and right channels are output (default).

L: Only the left channel is output.

R: Only the right channel is output.

PL IIX Music Mode Settings

These settings provide for playing any 2-channel digital source such as Dolby Digital, or 2-channel analog/PCM source in the PLIIX Music listening mode.

■ Panorama

With this function, you can broaden the width of the front stereo image when using the Pro Logic II Music or Pro Logic IIX Music listening mode.

On: Panorama function on.

Off: Panorama function off (default).

■ Dimension

With this setting, you can move the sound field forward or backward when using the Pro Logic II Music or Pro Logic IIX Music listening mode. The default setting is 3. Higher settings move the sound field forward. Lower settings move it backward.

If the stereo image feels too wide, or there is too much surround sound, move the sound field forward to improve the balance. Conversely, if the stereo image feels like it is in mono, or there is not enough surround sound, move it backward.

■ Center Width

With this function, you can adjust the width of the sound from the center speaker when using the Pro Logic II Music or Pro Logic IIX Music listening mode. Normally if you are using a center speaker, the center channel sound is output by only the center speaker. (If you are not using a center speaker, the center channel sound will be distributed to the front left and right speakers to create a phantom center). This setting controls the front left, right, and center mix, allowing you to adjust the weight of the center channel sound. It can be adjusted from 0 to 7 (default is 3).

Neo:6 Music Mode Setting

■ Center Image

The DTS Neo:6 Music listening mode creates 6-channel surround sound from 2-channel (stereo) sources. With this setting, you can specify by how much the front left and right channel output is attenuated in order to create the center channel. It can be adjusted from 0 to 5 (default is 3). This setting is unavailable if no surround speakers are connected.

When set to 0, the front left and right channel output is attenuated by half (–6 dB), giving the impression that the sound is located centrally. This setting works well when the listening position is considerably off center. When set to 5, the front left and right channels are not attenuated, maintaining the original stereo balance.

Dolby Digital EX Input Signal Setting

■ Dolby D EX

This setting determines how Dolby Digital EX signals are handled. This setting is unavailable if no surround back speakers are connected.

Auto: If the source signal contains a Dolby Digital EX flag, the Dolby Digital EX listening mode is used (default).

Manual: You can select Pro Logic IIX Movie, Pro Logic IIX Music, Dolby Digital, or Dolby Digital EX.

Assigning Listening Modes to Input Sources

You can assign a default listening mode to each input source that will be selected automatically when you select each input source. For example, you can set the default listening mode to be used with Dolby Digital input signals. You can select other listening modes during playback, but the mode specified here will be resumed once the AV receiver has been set to Standby.



1 Press the [RECEIVER] button followed by the [SETUP] button.

The main menu appears onscreen.

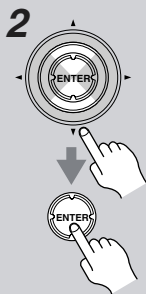

2 Use the Up and Down [▲]/[▼] buttons to select “7. Input Setup,” and then press [ENTER].

The Input Setup menu appears.

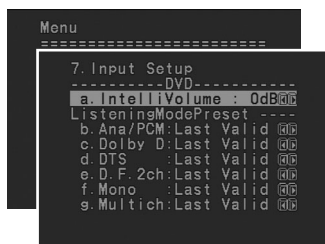

3 Use the INPUT SELECTOR buttons on the remote controller to select the input source that you want to set.

For input selectors that have no digital input jacks, only “b. Analog” will be available.



4 Use the Up and Down [▲]/[▼] buttons to select the signal format that you want to set, and then use the Left and Right [◀]/[▶] buttons to select a listening mode.

Only listening modes that can be used with each input signal format can be selected.

For “Surround,” the listening mode specified on page 69 will be used. The Last Valid option means that the listening mode selected last will be used.

b. Ana/PCM: With this setting, you can specify the listening mode to be used when an analog (CD, TV, LD, VHS, MD, turntable, radio, cassette, cable, satellite, etc.) or PCM digital (CD, DVD, etc.) audio signal is played.

c. Dolby D: With this setting, you can specify the listening mode to be used when a Dolby Digital format digital audio signal is played (DVD, etc.).

d. DTS: With this setting, you can specify the listening mode to be used when a DTS format digital audio signal is played (DVD, LD, CD, etc.).

e. D.F. 2ch: With this setting, you can specify the listening mode to be used when a 2-channel (2/0) digital audio signal (Dolby Digital, DTS) is played (DVD, etc.).

f. Mono: With this setting, you can specify the listening mode to be used when a mono digital audio signal is played (DVD, etc.).

g. Multich: This setting is available only when DVD or MULTI CH is selected with INPUT SELECTOR. With this setting, you can specify the listening mode to be used when the DVD analog multichannel input is used.



5 When you’ve finished, press the [SETUP] button.

The setup menu closes.

Note:

This procedure can also be performed on the AV receiver by using its [SETUP] button, arrow buttons, and [ENTER] button.

IntelliVolume

You can set the input level for each input source. This is useful if some of your AV components are louder or quieter than others.

While this menu is shown onscreen, you can select each input source and set the levels while listening to and comparing them.

1

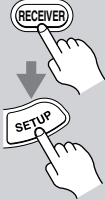

Press the [RECEIVER] button followed by the [SETUP] button.

The main menu appears onscreen.

2

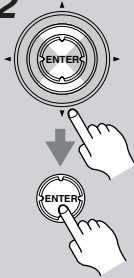

Use the Up and Down [▲]/[▼] buttons to select “7. Input Setup,” and then press [ENTER].

The Input Setup menu appears.

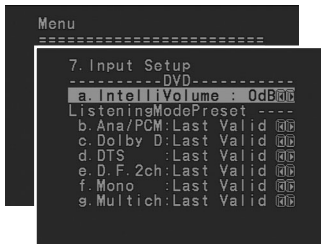

3



Use the INPUT SELECTOR buttons on the remote controller to select the input source that you want to set.

4



Use the Up and Down [▲]/[▼] buttons to select “a. IntelliVolume.”

If a component is too loud compared to your other components, use the Left [◀] button to adjust the level. If it’s too quiet, use the Right [▶] button.

- The level can be set from –6 dB to +6 dB.

Setting Preferences

This section explains the items on the Preference menu.

1



Press the [RECEIVER] button followed by the [SETUP] button.

The main menu appears onscreen.

2

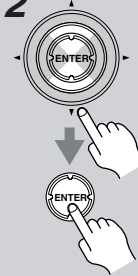

Use the Up and Down [▲]/[▼] buttons to select “8. Preference,” and then press [ENTER].

The Preference menu appears.

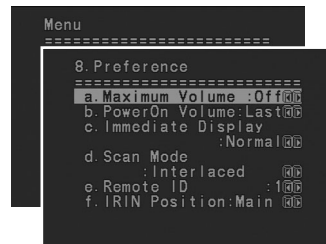

3

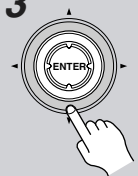

Use the Up and Down [▲]/[▼] buttons to select the settings, and use the Left and Right [◀]/[▶] buttons to set them.

The settings are explained on page 72.

4



When you’ve finished, press the [SETUP] button.

The setup menu closes.

Note:

This procedure can also be performed on the AV receiver by using its [SETUP] button, arrow buttons, and [ENTER] button.

a. Maximum Volume

With this preference, you can prevent the volume being set too high by specifying a maximum volume level. The range is from 50 to 99. To specify no maximum volume, select Off.

b. Power On Volume

With this preference, you can specify the volume setting to be used each time the AV receiver is turned on. The range is MIN, 1 through 50. To use the same volume level that was used when the AV receiver was turned off, select Last.

c. Immediate Display

This preference determines whether or not actions, such as selecting an input source, are displayed onscreen.

Normal: Select if your TV is 4:3.

Wide: Select if your TV is 16:9.

Off: Actions not displayed.

Even if this preference is set to Normal or Wide, actions are not displayed on the TV or projector that's connected to the COMPONENT VIDEO OUT.

d. Scan Mode

If the text in onscreen setup menus flickers due to compatibility with the connected display device (TV, projector, etc.), set the Scan Mode to Non-Interlaced.

Interlaced: Default.

Non-Interlaced: Select if the text flickers.

- Depending on the display device, when Non-Interlaced is selected, the onscreen setup menus may not appear. If this happens, use the AV receiver's display and repeat the procedure to revert to Interlaced.

e. Remote ID

With this setting, you can change the AV Receiver's remote control ID. You may need to change this if the remote controller's control codes overlap with those of another Onkyo component located in the same room.

- If you change the AV receiver's remote control ID, be sure to set the same ID on both the AV receiver and remote controller (see page 73). The default ID for both is 1.

f. IR IN Position

When using a commercially available IR receiver, use this setting to specify its location.

Main: Select if the IR receiver is located in the main room.

Zone 2: Select if the IR receiver is located in, and will be used to control Zone 2.

Digital Input Signal Formats

The digital input signal formats are available only for the input sources that you have assigned a digital input jack; otherwise you will see "Analog" indicated on the screen (see page 42).

Normally, the AV receiver detects the signal format automatically. However, if you experience either of the following issues when playing PCM or DTS material, you can manually set the signal format to PCM or DTS:

- If the beginnings of tracks from a PCM source are cut off, try setting the format to PCM.
- If noise is produced when fast forwarding or reversing a DTS CD, try setting the format to DTS.

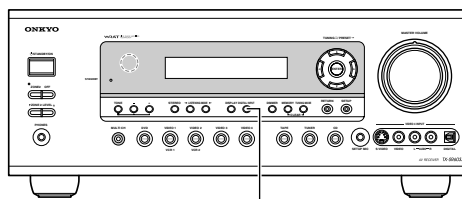

DIGITAL INPUT

- 1** Press and hold the AV receiver's [DIGITAL INPUT] button for about 3 seconds.
- 2** While "Auto" is displayed (about 3 seconds), press the [DIGITAL INPUT] button again to select: **PCM, DTS, or Auto.**
DTS or PCM: The DTS or PCM indicator, depending on which format you have set, flashes, and only signals in that format are output. Digital signals in other formats are ignored.
Auto (default): The format is detected automatically. If no digital input signal is present, the corresponding analog input is used instead.

Changing the Remote Controller's ID

If several Onkyo components are used in the same room, the remote controller's control codes may overlap with those of another component. To differentiate the remote controller's control codes, you can change its ID to another number.

Notes:

If you change the remote controller's ID, be sure to set the same ID on both the remote controller and AV receiver (see "e. Remote ID" on page 72). The default ID for both is 1.

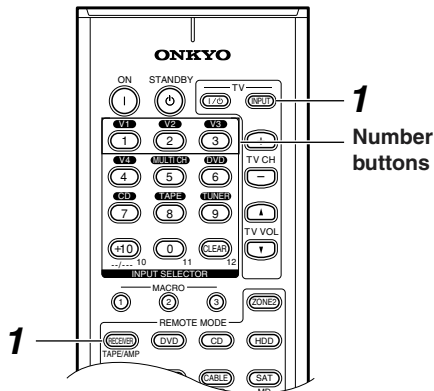

1 Press and hold down the [RECEIVER] button, and then press the TV [INPUT] button.

2 Use the number buttons to enter a remote control ID.

You can enter 1, 2, or 3.

Zone 2

Connecting Zone 2

With the Zone 2 function, you can enjoy one input source in the main room and a different source in another room.

There are two connection methods: using a receiver/integrated amp in Zone 2 or using only a pair of speakers in Zone 2.

Using a Receiver/Integrated Amp in Zone 2

With this connection method, you can use 7.1 surround sound in the main room and play a different AV source in Zone 2. The volume for Zone 2 is set on the receiver/integrated amp.

- Use an RCA audio cable to connect the AV receiver's ZONE 2 LINE OUT L/R jacks to an analog audio input on your receiver/integrated amp.
- Connect the Zone 2 speakers to the speaker terminals on the receiver/integrated amp.

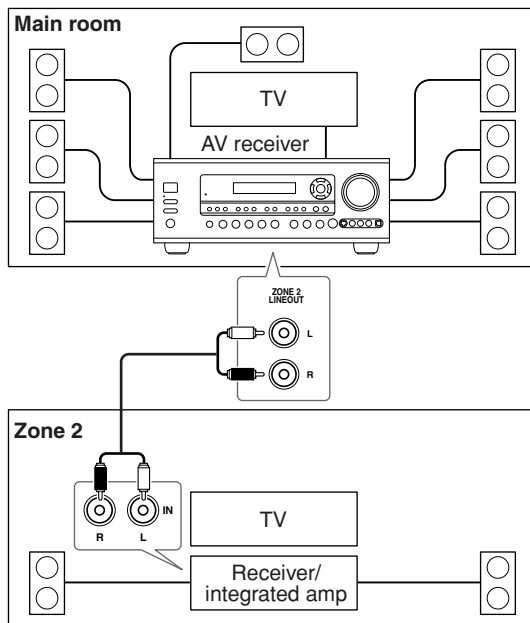

Using Only Speakers in Zone 2

With this connection method, you can use 5.1 surround sound in the main room and play a different AV source in Zone 2. The volume for Zone 2 is set on the AV receiver.

- Set the Powered Zone 2 setting to Activated (see page 75).
- Connect your Zone 2 speakers to the AV receiver's ZONE 2 SPEAKERS terminals.

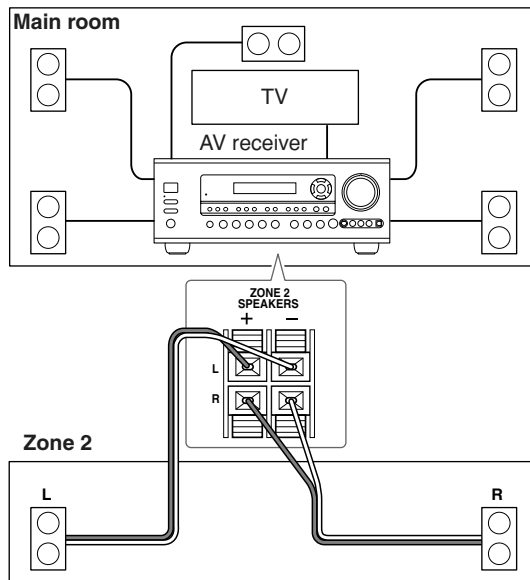

Setting the Powered Zone 2

To use Zone 2, you must make this setting. It enables the speakers connected to the ZONE 2 SPEAKERS terminals so that they produce sound when Zone 2 is used.

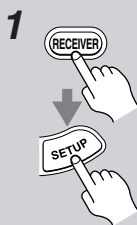
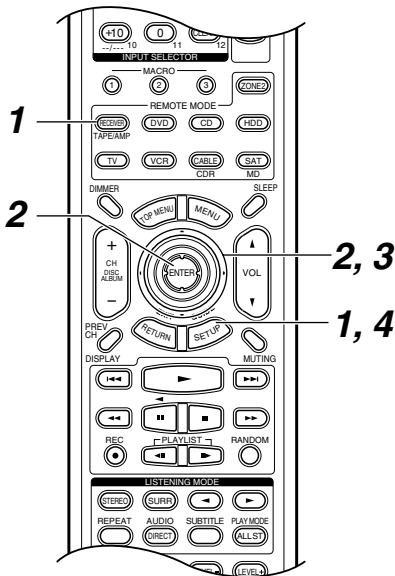

1 Press the [RECEIVER] button followed by the [SETUP] button. The main menu appears onscreen.

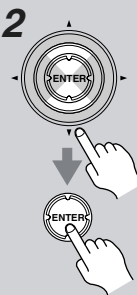

2 Use the Up and Down [▲]/[▼] buttons to select “0. Initial Setup,” and then press [ENTER]. The Initial Setup menu appears.



3 Use the Up and Down [▲]/[▼] buttons to select “f. Powered Zone 2,” and use the Left and Right [◀]/[▶] buttons to select:

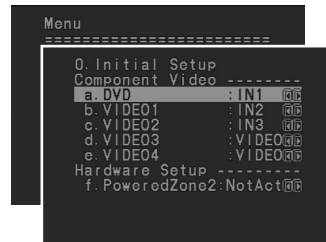

Not Activated: Zone 2 SPEAKERS terminals deactivated.

Activated: Zone 2 SPEAKERS terminals activated.

When Zone 2 is activated and turned on (see page 76), the speakers connected to the ZONE 2 SPEAKERS terminals output sound, but the speakers connected to the SURROUND BACK SPEAKERS terminals do not (when Zone 2 is activated but not used, the surround back speakers work as normal).



4 Press the [SETUP] button. The setup menu closes.

Note:

This procedure can also be performed on the AV receiver by using its [SETUP] button, arrow buttons, and [ENTER] button.

Using Zone 2

Here you can turn on Zone 2, select an input source, and adjust the volume.

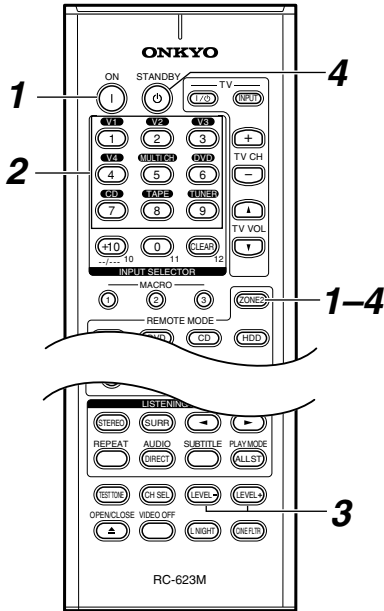

Note:
To control Zone 2 with the remote controller, you must press the [ZONE 2] button first.

1 **Point the remote controller at the AV receiver and press the [ZONE 2] button followed by the [ON] button.**
This turns on Zone 2 and the AV receiver's 12V TRIGGER OUT.

2 **To select the Zone 2 input source with the remote controller, press the [ZONE 2] button followed by an input selector button.**
If you select AM or FM, you can use the remote controller's [TUNER] button to select the band.
To perform steps 1 and 2 on the AV receiver, press the [ZONE 2] button followed by an input selector button within eight seconds.
The name of the selected Zone 2 source appears on the display.

To set Zone 2 to the same source as the main room, press the [ZONE 2] button repeatedly to display "Zone 2 Sel: Source."

3 **To adjust the Zone 2 volume with the remote controller, press the [ZONE 2] button, and then use the [LEVEL-] and [LEVEL+] buttons.**
To do this on the AV receiver, press the ZONE 2 LEVEL [▲]/[▼] buttons.
If the Zone 2 receiver/integrated amp is connected to the AV receiver's ZONE 2 LINE OUT L/R jacks, use the volume control on the receiver/integrated amp.

4 **To turn off Zone 2 with the remote controller, press the [ZONE 2] button followed by the [STANDBY] button.**
To do this from the AV receiver, press the [OFF] button.

- Notes:**
- Only analog input sources are output by the ZONE 2 LINE OUT and ZONE 2 SPEAKERS terminals. Digital input sources are not output. If no sound is heard when an input source is selected, check if it's connected to an analog input.
 - While Zone 2 is being used, listening modes that need surround back speakers (i.e., Dolby Digital EX and DTS-ES) are unavailable.
 - While Zone 2 is on, **RI** functions will not work.
 - You can't select different radio stations for Zone 2 and the main room. For example, if you have an FM station for the main room, that station will also be used in Zone 2.

Using the 12V Trigger

When Zone 2 is turned on, the ZONE 2 12V TRIGGER OUT outputs 12 volts (100 milliamperes max). By connecting this jack to the 12-volt trigger input on, say, a power amp in Zone 2, that power amp will turn on and off automatically as and when Zone 2 is turned on and off on the AV receiver.

Using the Remote Control in Zone 2

To use the remote controller to control the AV receiver from Zone 2, you'll need one of the following commercially available multiroom remote control kits:

- Multiroom Kits are made by Niles and Xantech. These kits can also be used when the AV receiver is not in line of sight of the remote controller, for example, when it's installed inside a cabinet.

Using a Multiroom Kit with Zone 2

In the following diagram, an IR receiver picks up the infrared signals from the remote controller in Zone 2 and feeds them to the AV receiver in the main room via the connecting block.

- On the Remote Setup menu, set the IR IN Position setting to "Zone 2" (see page 72).

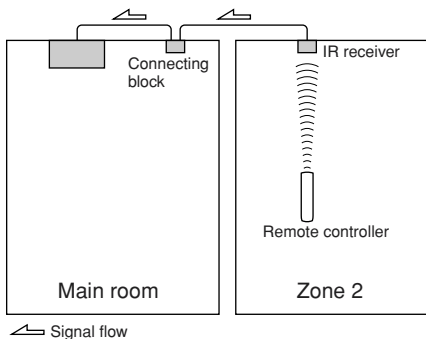

Connect the miniplug cable from the connecting block to the AV receiver's IR IN jack as shown below.

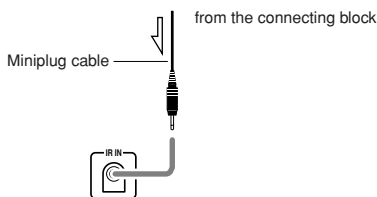

Using a Multiroom Kit with a Cabinet

In the following diagram, an IR receiver picks up the infrared signals from the remote controller and feeds them to the AV receiver in the cabinet via the connecting block.

- On the Remote Setup menu, set the IR IN Position setting to "Main" (see page 72).

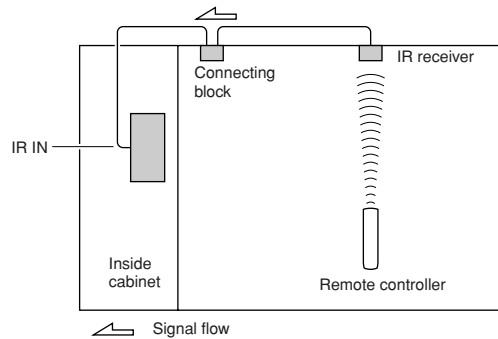

Controlling Other Components

You can use the AV receiver's remote controller (RC-623M) to control your other AV components, including those made by other manufacturers.

This section explains how to:

- Enter the remote control code for a component that you want to control (e.g., DVD, TV, VCR).
- Learn commands directly from another component's remote controller (see page 81).
- Program the MACRO buttons to perform a sequence of up to eight actions (see page 82).

Entering Remote Control Codes

Entering a remote control code for a REMOTE MODE button allows you to control an other component with the remote controller. You'll need to enter a code for each component that you want to control.

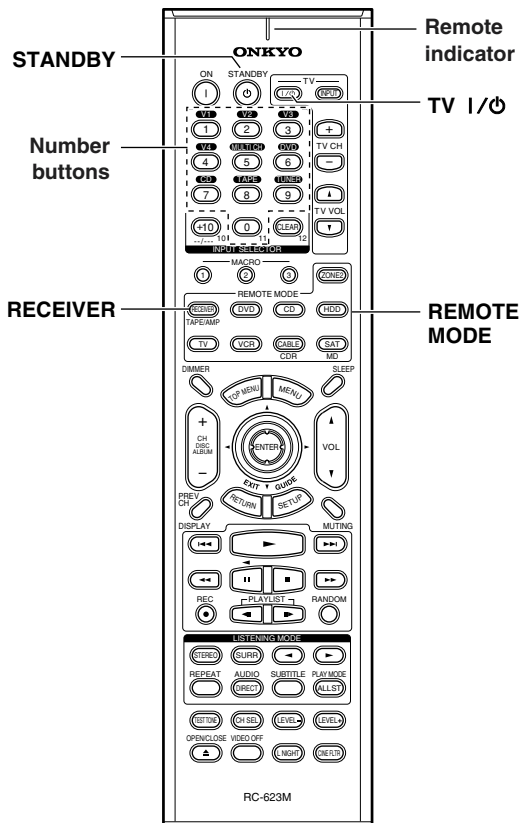

1

Look up the appropriate remote control code in the Remote Control Codes list.

The codes are organized by category.

2

REMOTE MODE

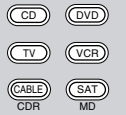

STANDBY



While holding down the REMOTE MODE button that you want to set, press the [STANDBY] button.

The Remote indicator lights up.

3



Within 30 seconds, use the number buttons to enter the 4-digit remote control code.

The Remote indicator flashes twice.

4

Press the REMOTE MODE button again to select the remote controller mode, point the remote controller at the component, and operate it.

If the remote controller doesn't work as expected, and several remote codes are listed, try each one in turn and use the one that works best.

Notes:

- Remote control codes cannot be entered for the [RECEIVER], [HDD], and [ZONE 2] REMOTE MODE buttons.
- The remote control codes provided are correct at the time of printing, but are subject to change.

- The HDD remote mode can only be used with the Onkyo DS-A1 Remote Interactive Dock at this time.
- The [DVD] and [CD] REMOTE MODE buttons are preprogrammed for use with Onkyo DVD players and CD players respectively.
- To control another manufacturer's CD recorder or MD recorder, enter the appropriate control code to the [CD] REMOTE MODE button.

Remote Control Codes for Onkyo Components Connected via RI

Onkyo components that are connected via **RI** are controlled by pointing the remote controller at the AV receiver, not the component. This allows you to control components that are out of view, in a rack, for example.

- 1** Make sure the Onkyo component is connected with an **RI** cable and an analog audio cable (RCA).
See page 36 for details.
- 2** Enter the appropriate remote control code for the REMOTE MODE button.
 - [DVD] REMOTE MODE button
5002: Onkyo DVD player with **RI**
 - [CD] REMOTE MODE button
6002: Onkyo CD player with **RI**
 - [MD] REMOTE MODE button
6008: Onkyo MD recorder with **RI**
 - [CDR] REMOTE MODE button
6006: Onkyo CD recorder with **RI**

See the previous page for how to enter remote control codes.
- 3** Press the REMOTE MODE button, point the remote controller at the AV receiver, and operate the component.

If you want to control an Onkyo component by pointing the remote controller directly at it, or you want to control an Onkyo component that's not connected via **RI**, use the following remote control codes:

- [DVD] REMOTE MODE button
5001: Onkyo DVD player without **RI** (default)
- [CD] REMOTE MODE button
6001: Onkyo CD player without **RI** (default)
- [MD] REMOTE MODE button
6007: Onkyo MD recorder without **RI**
- [CDR] REMOTE MODE button
6005: Onkyo CD recorder without **RI**

Note:

If you connect an **RI**-capable Onkyo MiniDisc or CD recorder to the TAPE IN/OUT jacks, for remote operation to work properly, you must set the display to MD or CDR (see page 50).

Resetting the REMOTE MODE Buttons

You can reset a REMOTE MODE button to its default remote control code.

- 1**

While holding down the REMOTE MODE button that you want to reset, press the TV [I/⏻] button.
The Remote indicator flashes three times.

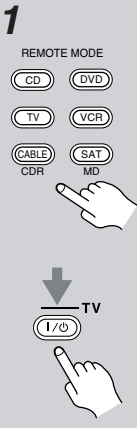
- 2**

Press the REMOTE MODE button again.
The Remote indicator flashes twice, indicating that the button has been reset.

The [DVD] and [CD] REMOTE MODE buttons are preprogrammed with remote control codes for controlling Onkyo DVD players and CD players respectively. When these buttons are reset, the preprogrammed code is restored.

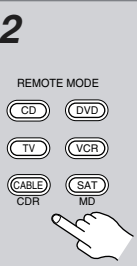

Resetting the Remote Controller

You can reset the remote controller to its default settings.

- 1**

While holding down the [RECEIVER] REMOTE MODE button, press the [STANDBY] button.
The Remote indicator flashes five times.

- 2**

Press the [RECEIVER] REMOTE MODE button again.
The Remote indicator flashes twice, indicating that the remote controller has been reset.



Controlling Other Components—Continued

- To control another component, point the remote controller at it and use the buttons explained below. (You must select the appropriate remote control mode first.) With some AV components, certain buttons may not work as expected, and some may not work at all.

■ Controlling a TV

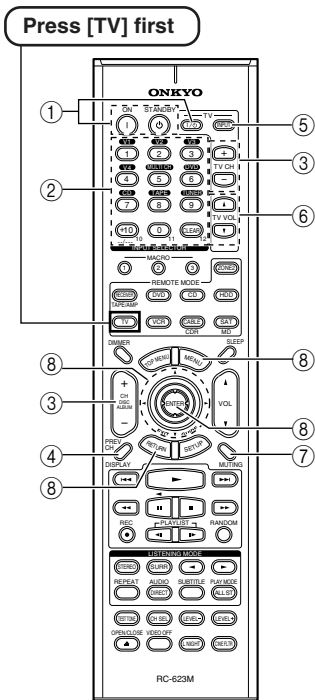

- [ON], [STANDBY], TV**
[I/⏻]*
Sets the TV to On or Standby.
- Number buttons**
Enter numbers.
- [CH +/-], TV CH [+]/[-]***
Selects channels on the TV.
- [PREV CH]**
Selects the previous channel.
- [TV INPUT]***
Selects the TV's input.
- TV VOL [▲]/[▼]***
Adjusts the TV's volume.
- [MUTING]**
Mutes the TV.
- [▲]/[▼]/[◀]/[▶]/[MENU]/
[ENTER]/[RETURN]**
Navigate menus on the TV.

* Buttons marked with an asterisk (*) are exclusively for controlling a TV and can be used at anytime regardless of the current remote controller mode.

■ Controlling a VCR

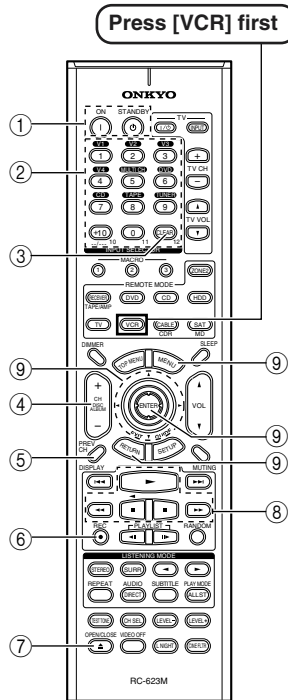

- [ON], [STANDBY]**
Sets the VCR to On or Standby.
- Number buttons**
Select channels.
- [CLEAR]**
Cancels functions.
- [CH +/-]**
Selects channels on the VCR.
- [PREV CH]**
Selects the previous channel.
- REC [●]**
Starts recording.
- Eject [▲]**
Ejects the videocassette.
- [▶], [⏸], [■], [◀], [▶▶]**
Play, Pause, Stop, Rewind, and Fast forward.
- [▲]/[▼]/[◀]/[▶]/[MENU]/
[ENTER]/[RETURN]**
Navigate menus on the VCR.

■ Controlling a Satellite or Cable Receiver

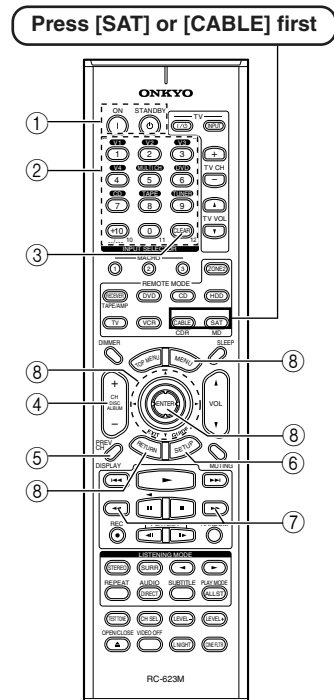

- [ON], [STANDBY]**
Sets the satellite/cable receiver to On or Standby.
- Number buttons**
Enter numbers.
- [CLEAR]**
Cancels functions.
- [CH +/-]**
Selects satellite/cable channels.
- [PREV CH]**
Selects the previous channel.
- [GUIDE]**
Displays the program guide.
- [◀◀], [▶▶]**
Rewind, and Fast forward.
- [▲]/[▼]/[◀]/[▶]/[MENU]/
[ENTER]/[RETURN]**
Navigate menus on the satellite/cable receiver.

Learning Commands from Other Remote Controllers

The AV receiver's remote controller can receive and learn commands from other remote controllers. By transmitting, for example, the Play command from your CD player's remote controller, the remote controller can learn it and then transmit the exact same command when its Play [▶] button is pressed in CD mode.

You can also use this function to learn individual commands after entering a remote controller code (page 78).

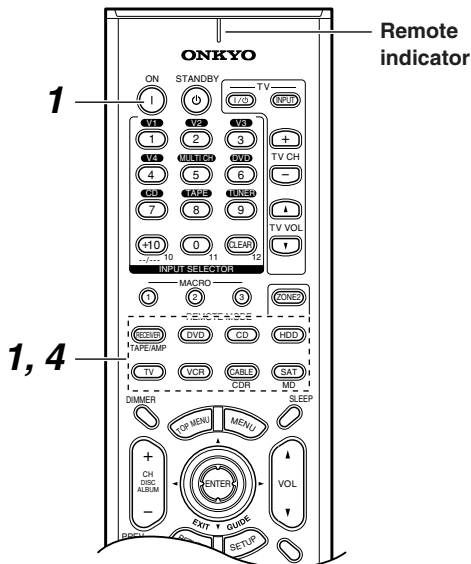

1 While holding down the **REMOTE MODE** button for the mode in which you want to use the command, press the **[ON]** button.

The Remote indicator lights up.

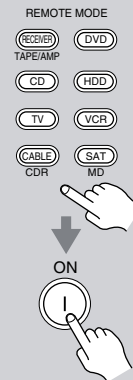

2 On the AV receiver's remote controller, press the button you want to learn the new command.

3 Point the remote controllers at each other, about 2 to 6 inches (5–15 cm) apart, and then press and hold the button whose command you want to learn until the Remote indicator flashes.

If the command is learned successfully, the Remote indicator flashes twice.

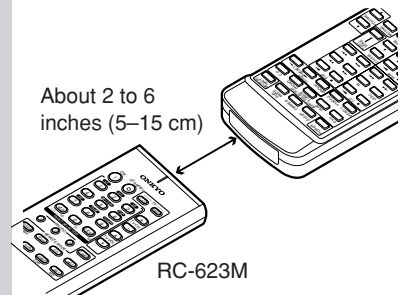

4 To learn more commands, repeat steps 2 and 3.

Press any REMOTE MODE button when you've finished.

Notes:

- The following buttons cannot learn new commands: REMOTE MODE, MACRO [1], [2], [3], TV [I/⏻], TV CH [+]/[-], TV [INPUT], TV VOL [▲]/[▼].
- The AV receiver's remote controller can learn approximately 70–90 commands, although, this will be reduced by commands that use a lot of memory.
- Remote controller buttons such as Play, Stop, Pause, and so on are preprogrammed with commands for controlling Onkyo CD players, cassette decks, and DVD players. However, they can learn new commands, and you can restore the preprogrammed commands by resetting the remote controller (page 79).
- To overwrite a previously learned command, repeat this procedure.
- Only commands from infrared remote controllers can be learned.
- When the remote controller's batteries expire, all learned commands will be lost and will have to be learned all over again, so don't discard your other remote controllers.

Using Macros

You can program the remote controller's MACRO buttons to perform a sequence of actions.

Example:

To play a CD, you typically need to perform the following actions:

1. Press the [RECEIVER] REMOTE MODE button to select Receiver mode.
2. Press the [ON] button to turn on the AV receiver.
3. Press the [CD] INPUT SELECTOR button to select the CD input source.
4. Press the REMOTE MODE [CD] button to select the CD remote controller mode.
5. Press the Play [▶] button to start playback on the CD player.

You can program a MACRO button to perform all five actions.

Making Macros

You can make one macro for each MACRO button, and each macro can perform up to eight actions.

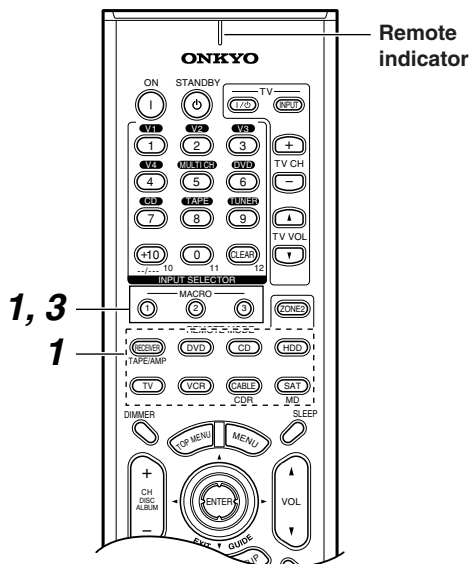

1

REMOTE MODE



2



While holding down the REMOTE MODE button for the mode you want to start with, press MACRO button [1], [2], or [3].

The Remote indicator lights up.

For the CD example in the left column, you'd press and hold the [RECEIVER] REMOTE MODE button, and then press MACRO button [1], [2], or [3].

2

On the remote controller, press the buttons whose actions you want to program into the macro in the order you want them performed.

For the CD example in the left column, you'd press the following buttons: [ON], INPUT SELECTOR [CD], REMOTE MODE [CD], Play [▶].

3

When you've finished, press the MACRO button again.

The Remote indicator flashes twice.

If you enter all eight actions, the process will finish automatically.

Note:

- If one or more of the buttons you used to make the macro are taught new commands, the macro will no longer work properly and will have to be made again.

Running Macros

1

Press the MACRO [1], [2], or [3] button.

The actions in the macro are performed in the order in which they were programmed.

Keep the remote controller pointed at the AV receiver until all of the commands have been finished. Macros can be run at anytime regardless of the current remote controller mode.

Deleting Macros

1

While holding down the [RECEIVER] REMOTE MODE button, press the MACRO button whose macro you want to delete.

2

Press the MACRO button again.

Specifications

Amplifier Section

Power Output 2 channel driven:	90 W + 90 W (8 Ω , 20 Hz–20 kHz, FTC)
Dynamic Power	225 W + 225 W (3 Ω , Front) 175 W + 175 W (4 Ω , Front) 105 W + 105 W (8 Ω , Front)
THD (Total Harmonic Distortion)	0.08 % (Power Rated)
Damping Factor	60 (Front, 1 kHz, 8 Ω)
Input Sensitivity and Impedance	200 mV/47 k Ω (LINE)
Output Level and Impedance	200 mV/470 Ω (REC OUT)
Frequency Response	10 Hz–100 kHz/+1 dB-3 dB (Direct mode)
Tone Control	\pm 10 dB, 50 Hz (BASS) \pm 10 dB, 20 kHz (TREBLE)
SN Ratio	106 dB (LINEIHF-A)
Speaker Impedance	6 Ω –

Video Section

Input Sensitivity/Output Level and Impedance	1 Vp-p/75 Ω (Component and S-Video Y) 0.7 Vp-p/75 Ω (Component Pb/Cb, Pr/Cr) 0.28 Vp-p/75 Ω (S-Video C) 1 Vp-p/75 Ω (Composite)
Component Video Frequency Response	5 Hz – 50 MHz

Tuner Section

FM

Tuning Frequency Range	87.5 MHz– 107.9 MHz
Usable Sensitivity	Stereo: 22.2 dBf (75 Ω IHF) Mono: 11.2 dBf (75 Ω IHF)
S/N Ratio	Stereo: 67 dB (IHF-A) Mono: 73 dB (IHF-A)
THD	Stereo: 0.5 % (1 kHz) Mono: 0.3 % (1 kHz)
Frequency Response	30 Hz–15 kHz / \pm 1 dB
Stereo Separation	40 dB (1kHz)

AM

Tuning Frequency Range	530 kHz–1710 kHz
Usable Sensitivity	300 μ V
S/N Ratio	40 dB
THD	0.70%

General

Power Supply	AC 120 V, 60 Hz
Power Consumption	7A
Stand-by Power Consumption	0.1 W
Dimensions (W x H x D)	435 W x 174 H x 377 D mm 17-1/8" W x 6-7/8" H x 14-13/16" D
Weight	11.0 kg 24.3 lbs

Video Inputs

Component Video Input	1,2,3
S-Video Compatible Jack Input	DVD, VIDEO1, VIDEO2, VIDEO3, VIDEO4
A/V Input	DVD, VIDEO1, VIDEO2, VIDEO3, VIDEO4

Video Outputs

Component Video Output	OUT
S-Video Compatible Jack Output	MONITOR OUT, VIDEO1, VIDEO2
A/V Output	MONITOR OUT, VIDEO1, VIDEO2

Audio Inputs

Digital Inputs	Optical: 4 Coaxial: 2
Analog Inputs	DVD(MULTICHANNEL), VIDEO1, VIDEO2, VIDEO3, VIDEO4, TAPE, CD
Multichannel Inputs	6

Audio Outputs

Digital Outputs	Optical: 1
Analog Outputs	TAPE, VIDEO1, VIDEO2, ZONE2
Subwoofer Pre Outputs	1
Speaker Outputs	9
Phones	1

Other Jacks

IR Input	1
12V Trigger Out	1

Specifications and features are subject to change without notice.

Troubleshooting

If you have any trouble using the AV receiver, look for a solution in this section. If you can't resolve the issue yourself, contact your Onkyo dealer.

Power

Can't turn on the AV receiver?

- Make sure that the power cord is properly plugged into the wall outlet.
- Unplug the power cord from the wall outlet, wait five seconds or more, then plug it in again.

The AV receiver turns off as soon as it's turned on?

- The amp protection circuit has been activated. Remove the power cord from the wall outlet immediately and contact your Onkyo dealer.

Audio

There's no sound, or it's very quiet?

- Make sure that all audio connecting plugs are pushed in all the way (page 20).
- Make sure that the inputs and outputs of all components are connected properly (page 20).
- Make sure that the polarity of the speaker cables is correct, and that the bare wires are in contact with the metal part of each speaker terminal (page 22).
- Make sure that the input source is properly selected (page 51).
- Make sure that the speaker cables are not shorting.
- Check the volume. It can be set to MIN, 1 through 99, or MAX (page 51). The AV receiver is designed for home theater enjoyment. It has a wide volume range, allowing precise adjustment.
- If the MUTING indicator is shown on the display, press the remote controller's [MUTING] button to unmute the AV receiver (page 52).
- While a pair of headphones is connected to the PHONES jack, no sound is output by the speakers (page 52).
- Check the digital audio output setting on the connected device. On some game consoles, such as those that support DVD, the default setting is off.
- With some DVD-Video discs, you need to select an audio output format from a menu.
- If your turntable doesn't have a built-in phono preamp, you must connect one between it and the AV receiver. If your turntable uses an MC cartridge, you must connect an MC head amp, or an MC transformer and phono equalizer.
- Make sure that none of the connecting cables are bent, twisted, or damaged.
- Not all listening modes use all speakers (page 62).

- Specify the speaker distances (page 47) and adjust the individual speaker levels (page 48).
- Make sure that the speaker setup microphone is not still connected.

Only the front speakers produce sound?

- When the Stereo listening mode is selected, only the front speakers and subwoofer produce sound.
- When the Direct listening mode is selected, only the front speakers produce sound.
- Make sure the speakers are configured correctly (page 44).

Only the center speaker produces sound?

- If you use the Pro Logic IIx Movie or Pro Logic IIx Music listening mode with a mono source, such as an AM radio station or mono TV program, the sound is concentrated in the center speaker.
- Make sure the speakers are configured correctly (page 44).

The surround speakers produce no sound?

- When the Stereo or Direct listening mode is selected, the surround speakers produce no sound (page 62).
- Depending on the source and current listening mode, not much sound may be produced by the surround speakers. Try selecting another listening mode.
- Make sure the speakers are configured correctly (page 44).

The center speaker produces no sound?

- When the Mono or Stereo listening mode is selected, the center speaker produces no sound (page 62).
- Make sure the speakers are configured correctly (page 44).

The surround back speakers produce no sound?

- The surround back speakers are not used with all listening modes. Select another listening mode (page 62).
- Not much sound may be produced by the surround back speakers with some sources.
- Make sure the speakers are configured correctly (page 44).

The subwoofer produces no sound?

- When you play source material that contains no information in the LFE channel, the subwoofer produces no sound.
- Make sure the speakers are configured correctly (page 44).

There's no sound with a certain signal format?

- Check the digital audio output setting on the connected device. On some game consoles, such as those that support DVD, the default setting is off.
- With some DVD-Video discs, you need to select an audio output format from a menu.
- Depending on the input signal, some listening modes cannot be selected (page 61).

Can't select the DTS-ES Discrete/Matrix listening modes?

- These modes cannot be selected when no surround back speakers are connected, or the Zone 2 speakers are being used.
- You can not always select all of the listening modes, depending on the number of the speaker connected (page 61).

Can't get 6.1 playback?

- If no surround back speakers are connected, or the Zone 2 speakers are being used, 6.1 playback is not possible.
- You can not always select all of the listening modes, depending on the number of the speakers connected (page 61).

The volume cannot be set to 99?

- When the levels of all speakers have been calibrated (page 48), the maximum volume setting may change.

Noise can be heard?

- Using cable ties to bundle audio cables with power cords, speaker cables, and so on may degrade the audio performance, so don't do it.
- An audio cable may be picking up interference. Try repositioning your cables.

The Late Night function doesn't work?

- Make sure the source material is Dolby Digital (page 64).

The DVD analog multichannel input doesn't work?

- Check the DVD analog multichannel input connections (page 28).
- To select the DVD analog multichannel input, press the [MULTI CH] input selector button.
- Check the audio output settings on your DVD player.

About DTS signals

- When DTS program material ends and the DTS bitstream stops, the AV receiver remains in DTS listening mode and the DTS indicator remains on. This is to prevent noise when you use the pause, fast forward, or fast reverse function on your player. If you switch your player from DTS to PCM, because the AV receiver does not switch formats immediately, you may not hear any sound, in which case you should stop your player for about three seconds, and then resume playback.
- With some CD and LD players, you won't be able to playback DTS material properly even though your player is connected to a digital input on the AV receiver. This is usually because the DTS bitstream has been processed (e.g., output level, sampling rate, or frequency response changed) and the AV receiver doesn't recognize it as a genuine DTS signal. In such cases, you may hear noise.
- When playing DTS program material, using the pause, fast forward, or fast reverse function on your player may produce a short audible noise. This is not a malfunction.

Video

There's no picture?

- Make sure that all video connecting plugs are pushed in all the way (page 20).
- Make sure that each video component is properly connected.
- If your video component is connected to a component video input, your TV must be connected to the component video output (page 25).
- On your TV, make sure that the video input to which the AV receiver is connected is selected.

The onscreen menus don't appear?

- Make sure that the video settings are correct (page 43).
- On your TV, make sure that the video input to which the AV receiver is connected is selected.

Tuner

Reception is noisy, FM stereo reception is noisy, or the FM STEREO indicator doesn't appear?

- Relocate your antenna.
- Move the AV receiver away from your TV or computer.
- Listen to the station in mono (page 54).
- When listening to an AM station, operating the remote controller may cause noise.
- Passing cars and airplanes can cause interference.
- Concrete walls weaken radio signals.
- If nothing improves the reception, install an outdoor antenna.

Can't select XM radio channels

- Channels cannot be selected while the ►◀ indicator is flashing, as tuning is in progress.

Remote Controller

The remote controller doesn't work?

- Make sure that the batteries are installed with the correct polarity (page 13).
- Install new batteries. Don't mix different types of batteries, or old and new batteries (page 13).
- Make sure that the remote controller is not too far away from the AV receiver, and that there's no obstruction between the remote controller and the AV receiver's remote control sensor (page 13).
- Make sure that the AV receiver is not subjected to direct sunshine or inverter-type fluorescent lights. Relocate if necessary.
- If the AV receiver is installed in a rack or cabinet with colored-glass doors, the remote controller may not work reliably when the doors are closed.
- Make sure you've selected the correct remote controller mode (pages 14-18).
- When using the remote controller to control other manufacturers' AV components, some buttons may not work as expected.
- Make sure you've entered the correct remote control code.
- Make sure to set the same ID on both the AV receiver and remote controller (pages 72 and 73).

Can't control other components?

- If it's an Onkyo component, make sure that the **RI** cable and analog audio cable are connected properly. Connecting only an **RI** cable won't work (page 36).
- Make sure you've selected the correct remote controller mode (pages 14-18).

- If you've connected an **RI**-capable Onkyo MD recorder, CD recorder, or next generation HDD-compatible component to the TAPE IN/OUT jacks, or a DS-A1 Remote Interactive Dock to the VIDEO 3 IN jacks, for the remote controller to work properly, you must set the display to MD, CDR, or HDD (see pages 50 and 79).
- When learning commands, make sure that the transmitting ends of both remote controllers are pointing at each other.
- Are you trying to learn from a remote controller that cannot be used for learning? Some commands cannot be learned, especially those that transmit several instructions with a single button press.
- The wrong remote control code has been entered.
- The entered remote control code may not be correct. If more than one code is listed, try each one.
- With some AV components, certain buttons may not work as expected, and some may not work at all.
- To control Onkyo components, point the remote controller at the AV receiver.
- To control another manufacturer's component, point the remote controller at that component.

Recording

Can't record?

- On your recorder, make sure the correct input is selected (e.g., digital or analog).

Zone 2

Zone 2 has turned off?

- Was the Sleep function set? The Sleep function turns off Zone 2 as well as the AV receiver. To set the Sleep function for Zone 2 only, see page 76.

There's no sound?

- Only components connected to analog inputs can be played in Zone 2.

Others

The sound changes when I connect my headphones?

- When a pair of headphones is connected, the listening mode is set to Stereo, unless it's already set to Stereo or Direct. When you disconnect the headphones, the previous listening mode will be resumed.

The speaker volume cannot be set as required?

- When the Automatic Speaker Setup function is used, or the volume is adjusted on the onscreen setup menus, the maximum possible volume setting may change.

The speaker distance cannot be set as required?

- In some cases, corrected values suitable for home theater use may be set automatically.

The display doesn't work?

- Actions are not displayed on the TV or projector that's connected to the COMPONENT VIDEO OUT.

How do I change the language of a multiplex source?

- Use the "a. Multiplex" setting on the "4. Audio Adjust" menu to select Main or Sub (page 69).

The functions Auto Power On/Standby and Direct Change don't work for components connected via RI?

- These functions don't work when Zone 2 is turned on.

The AV receiver contains a microcomputer for signal processing and control functions. In very rare situations, severe interference, noise from an external source, or static electricity may cause it to lockup. In the unlikely event that this happens, unplug the power cord from the wall outlet, wait at least five seconds, and then plug it back in again.

Onkyo is not responsible for damages (such as CD rental fees) due to unsuccessful recordings caused by the unit's malfunction. Before you record important data, make sure that the material will be recorded correctly.

Resetting the AV receiver to its factory defaults
To reset the AV receiver to its factory defaults, turn it on and, while holding down the [VIDEO 1] button, press the [STANDBY/ON] button. "CLEAR" will appear on the display and the AV receiver will enter Standby mode.

The AV receiver uses a battery-less memory backup system in order to retain radio presets and other settings when it's unplugged or in the case of a power failure. Although no batteries are required, the AV receiver must be plugged into an AC outlet in order to charge the backup system.

Before disconnecting the power cord from the wall outlet, set the AV receiver to Standby.

ONKYO CORPORATION

Sales & Product Planning Div. : 2-1, Nisshin-cho, Neyagawa-shi, OSAKA 572-8540, JAPAN
Tel: 072-831-8023 Fax: 072-831-8124

ONKYO U.S.A. CORPORATION

18 Park Way, Upper Saddle River, N.J. 07458, U.S.A.
Tel: 201-785-2600 Fax: 201-785-2650 <http://www.us.onkyo.com/>

ONKYO EUROPE ELECTRONICS GmbH

Liegnitzerstrasse 6, 82194 Groebenzell, GERMANY
Tel: +49-8142-4401-0 Fax: +49-8142-4401-555 <http://www.eu.onkyo.com/>

ONKYO EUROPE UK Office

Suite 1, Gregories Court, Gregories Road, Beaconsfield, Buckinghamshire, HP9 1HQ
UNITED KINGDOM Tel: +44-(0)1494-681515 Fax: +44(0)-1494-680452

ONKYO CHINA LIMITED

Units 2102-2107, Metroplaza Tower I, 223 Hing Fong Road, Kwai Chung,
N.T., HONG KONG Tel: 852-2429-3118 Fax: 852-2428-9039
<http://www.ch.onkyo.com/>



D0508-1

SN 29344095

(C) Copyright 2005 ONKYO CORPORATION Japan. All rights reserved.
Downloaded from www.onkyo.com. All Manuals Search And Download



* 2 9 3 4 4 0 9 5 *

Remote Control Codes

Códigos de control remoto

Fernbedienungs-codes

Fjärrstyrningskoder

Codes de télécommande

Codici del telecomando

Afstandsbedieningscodes

遙控代碼

遥控代码

RC-620M / 621M / 622M / 623M / 630M / 631M / 632M

DVD Codes

DVD player	
Acoustic Solutions	0757
Alba	0744
Amstrad	0740
Apex Digital	0699, 0744, 0782, 0821, 0823, 0857, 1127
Blaupunkt	0744
Blue Parade	0598
Bush	0740
Centrex	0699
Clatronic	0815
CyberHome	0741
DVD2000	0548
Daewoo	0811, 0797
Dansai	0797
Decca	0797
Denon	0517
Diamond	0795
Digitrex	0699
Emerson	0618
Enterprise	0618
Fisher	0697
GE	0549, 0744
Go Video	0742
GoldStar	0768
Gradiente	0678
Greenhill	0744
Grundig	0566
Hitachi	0600, 0691
Hiteker	0699
JVC	0585, 0650
KLH	0744
Kenwood	0517, 0561
Koss	0678
LG	0768
Limit	0795
Magnavox	0530, 0702
Marantz	0566
Memorex	0858
MiCO	0750
Microsoft	0549
Mintek	0744
Mitsubishi	0548
Mustek	0757
Nesa	0744
Onkyo	5001, 5002 (RI)
Oritron	0678
Palsonic	0699
Panasonic	0517, 0659, 1389
Philips	0530, 0566, 0673, 0881
Pioneer	0552, 0598, 0658, 0659
Polk Audio	0566
Proscan	0549
Qwestar	0678

DVD player	
RCA	0549, 0598, 0744
Rotel	0650
SM Electronic	0757
Samsung	0600
Sanyo	0697
Sharp	0657
Sherwood	0797
Shinasonic	0560
Slim Art	0811
Sony	0560, 0891
Sylvania	0702
Tatung	0797
Teac	0598, 0744
Technics	0517
Theta Digital	0598
Thomson	0549
Toshiba	0530
Urban Concepts	0530
XBox	0549
Yamaha	0517, 0566, 0572
Zenith	0530, 0618, 0768
Zeus	0811

DVD Recorder	
Panasonic	5006
Pioneer	5004
Sharp	5003
Sony	5007
Toshiba	5005

CD Codes

CD player	
Aiwa	0184
Arcam	0184
Audio Research	0184
AudioTon	0184
Audiolab	0184
Audiomeca	0184
Cairn	0184
California Audio Labs	0056
Carver	0184, 0206
Cyrus	0184
DKK	0027
DMX Electronics	0184
Denon	0900
Dynamic Bass	0206
Emerson	0332
Fisher	0206
Genexxa	0059, 0332
Goodmans	0332
Grundig	0184
Harman/Kardon	0184, 0200
Hitachi	0059

CD player	
JVC	0099
Kenwood	0708, 0653, 0055, 0064
Krell	0184
LXI	0332
Linn	0184
MCS	0056
Magnavox	0184, 0332
Marantz	0653, 0056, 0184
Matsui	0184
Memorex	0332
Meridian	0184
Micromega	0184
Miro	0027
Mission	0184
Myryad	0184
NAD	0027
NSM	0184
Naim	0184
Onkyo	6001, 6002 (RI)
Optimus	0027, 0059, 0064, 0206, 0332
Panasonic	0056
Philips	0653, 0184
Pioneer	0059, 0332
Polk Audio	0184
Proton	0184
QED	0184
Quad	0184
Quasar	0056
RCA	0059, 0206, 0332
Realistic	0206
Revox	0184
Rotel	0184
SAE	0184
Sansui	0184, 0332
Sanyo	0206
Scott	0332
Sears	0332
Sharp	0888, 0064
Simaudio	0184
Sonic Frontiers	0184
Sony	0517, 0027
Symphonic	0332
TAG McLaren	0184
Tandy	0059
Technics	0056
Thorens	0184
Thule	0184
Universum	0184
Victor	0099
Wards	0184

MD recorder	
Kenwood	0708
Sharp	0888
Sony	0517

CD recorder	
Kenwood	0653
Marantz	0653
Philips	0653

TV Codes

TV	
AGB	0543
AOC	0478, 0120, 0207, 0087, 0057, 0205, 0036, 0119, 0135
ASA	0131
AWA	0036
Acura	0036
Addison	0119, 0135, 0680
Admiral	0120, 0490, 0190
Advent	0788
Aiko	0119
Akai	0839, 0729, 0057, 0036, 0235, 0388, 0543
Akura	0291
Alba	0036, 0064, 0398, 0695
America Action	0207
Ampro	0778
Amstrad	0198, 0036, 0064, 0398, 0439, 0460, 0543
Anam	0277, 0207, 0036
Anam National	0277, 0677
Anitech	0036
Apex Digital	0775, 0792, 0794
Audiosonic	0064, 0136
Audiovox	0478, 0207, 0119, 0650
Bang & Olufsen	0592
Basic Line	0036
Baur	0064, 0388, 0539
Baysonic	0207
Beaumarck	0205
Beko	0397, 0513, 0741, 0742
Bell & Howell	0181
Beon	0064
Blaupunkt	0222
Blue Sky	0695, 1064
Bondstec	0274
Bradford	0207
Brandt	0136, 0362
Broksonic	0263, 0490
Bush	0036, 0064, 0398, 0401, 0695, 1064
CCE	0064
CGE	0274
CTC	0274
CXC	0207
Candle	0057
Carnivale	0057

TV	
Carver	0081, 0197
Cascade	0036
Cathay	0064
Celebrity	0027
Celera	0792
Centurion	0064
Changhong	0792
Ching Tai	0036, 0119
Chun Yun	0027, 0207, 0036, 0119
Chung Hsin	0207, 0080, 0135
Cimline	0036
Cineral	0478, 0119
Citizen	0087, 0057, 0119
Clarion	0207
Clarivox	0064
Clatronic	0274, 0397
Condor	0347, 0397
Conrac	0835
Contec	0207, 0036
Craig	0207
Crosley	0081
Crown	0207, 0036, 0064, 0397, 0445
Curtis Mathes	0074, 0081, 0181, 0478, 0120, 0087, 0729, 0057, 0172, 0193, 1174, 1374
Daewoo	0181, 0478, 0207, 0057, 0205, 1688, 0036, 0064, 0119, 0135, 0197, 0401, 0650, 0661
Dansai	0064
Dayton	0036
De Graaf	0235, 0575
Decca	0064, 0543
Denon	0172
Digatron	0064
Dixi	0036, 0064
Dumont	0044
Dwin	0747, 0801
ECE	0064
Elbe	0286
Electroband	0027
Elin	0064, 0575
Elite	0347
Elta	0036
Emerson	0181, 0263, 0490, 0207, 0205, 0388, 0650
Envision	0057, 0840
Epson	0860, 6004
Erres	0064
Ether	0057, 0036
Etron	0036
Europhon	0543
Ferguson	0064, 0100, 0136, 0265, 0314, 0362, 0587
Fidelity	0388
Finlandia	0235, 0373
Finlux	0064, 0131, 0132, 0373, 0543
Firstar	0263, 0036
Firstline	0036, 0274, 0695
Fisher	0181, 0131, 0235, 0397
Flint	0482
Formenti	0064, 0347
Fortress	0120
Frontech	0190, 0274, 0291
Fujitsu	0710, 0836
Funai	0207, 0198, 0291
Futuretech	0207
GE	0074, 0078, 0478, 0207, 0057, 0205, 1481, 0119, 0587, 1174, 1374
GEC	0064, 0543

TV	
Gateway	1782, 1783
Geloso	0036
Genexxa	0190
Gibralter	0044, 0057
GoldStar	0181, 0057, 0205, 0064, 0136, 0404
Goodmans	0064, 0398, 0401, 0661
Gorenje	0397
Gradiente	0080, 0197
Graetz	0190, 0388
Granada	0064, 0235, 0366, 0543
Grandin	0637
Grundig	0064, 0222, 0514, 0583, 0614
Grunpy	0207
HCM	0036, 0439
Hallmark	0205
Hankook	0207, 0057, 0205
Hanseatic	0064, 0347, 0388, 0455, 0583
Hantarex	0543
Harman/Kardon	0081
Harvard	0207
Havermy	0120
Hello Kitty	0478
Hinari	0036, 0064
Hisawa	0482
Hitachi	0057, 0205, 1172, 0172, 1283, 0036, 0119, 0132, 0136, 0190, 0252, 0383, 0508, 0575, 0605
Hua Tun	0036
Huanyu	0401
Hypson	0064, 0291
ICE	0291, 0398
ITS	0398
ITT	0190, 0388, 0575
Imperial	0274, 0397, 0445
Indiana	0064
Infinity	0081
Ingelen	0190
Inno Hit	0543
Innova	0064
Inteq	0044
Interfunk	0064, 0190, 0274, 0388, 0539
Intervision	0064, 0291, 0404
JBL	0081
JCB	0027
JVC	0490, 0080, 0398, 0680, 0710
Jean	0183, 0078, 0263, 0036, 0119
Jensen	0788
KEC	0207
KTV	0207, 0057
Kaisui	0036
Kapsch	0190
Karcher	0637
Kathrein	0583
Kendo	0064
Kenwood	0057
Kneissel	0286, 0462
Kolin	0207, 0080, 0135
Korpel	0064
Koyoda	0036
L&S Electronic	0835
LG	0087, 0057, 0205, 0064, 0135, 0741
LXI	0074, 0081, 0181, 0183, 0205
Leyco	0064, 0291
Liesenk & Tter	0064
Loewe	0539
Luxor	0383, 0388

TV	
M Electronic	0036, 0064, 0131, 0132, 0136, 0190, 0314, 0373, 0401, 0507
MGA	0177, 0057, 0205
MTC	0087, 0057, 0539
Magnadyne	0274, 0543
Magnafon	0543
Magnavox	0081, 0057, 1481, 1281
Manesth	0291, 0347
Marantz	0081, 0057, 0064, 0583
Mark	0064
Matsui	0036, 0064, 0235, 0398, 0514, 0543
Matsushita	0277, 0677
Mediator	0064
Medion	0695, 0835, 1064
Megatron	0205, 0172
Memorex	0181, 0277, 0490, 0177, 0205, 0036, 1064
Metz	0474
Micromaxx	0835
Microstar	0835
Midland	0074, 0044, 0078
Minerva	0514
Minoka	0439
Mitsubishi	0181, 0277, 0120, 0283, 0207, 0177, 1277, 0057, 0205, 0135, 0539, 0863
Mivar	0318, 0319, 0543, 0636
Motorola	0120
Multitech	0207, 0036
Myryad	0583
NAD	0183, 0205, 0388, 0893
NEC	0181, 0183, 0078, 0057, 0205, 0036, 0197, 0482, 0524, 1731
NEI	0064
NTC	0119
Neckermann	0064, 0583
Netsat	0064
Newave	0120, 0205, 0036, 0119
Nikkai	0064, 0291
Nikko	0057, 0205, 0119
Nokia	0388, 0500, 0507, 0575, 0658
Norcent	0775, 0851
Nordmende	0136, 0314, 0587
Oceanic	0190, 0388
Onwa	0207, 0460
Optimus	0181, 0277, 0193, 0677
Optonica	0120
Orion	0263, 0490, 0064, 0347, 0543
Osaki	0291, 0439
Otto Versand	0064, 0347, 0539, 0583
Palladium	0397, 0445
Panama	0291
Panasonic	0081, 0277, 0078, 0064, 0190, 0677, 1437
Pathe Cinema	0265, 0347
Pausa	0036
Penney	0074, 0183, 0078, 0087, 0057, 0205, 1374
Perdio	0347
Philco	0081, 0490, 0207, 0057, 0205, 0172, 1688, 0064, 0274
Philips	0081, 0027, 0078, 0057, 0205, 1481, 0064, 0119, 0135, 0401, 0583, 0717

TV	
Phonola	0064
Pilot	0057
Pioneer	0193, 0136, 0190, 0314, 0706, 0787, 0893
Portland	0119
Prandoni-Prince	0543
Prima	0788
Prism	0078
Profex	0036, 0388
Proscan	0074
Protech	0036, 0064, 0274, 0291, 0445, 0695
Proton	0057, 0205, 0036
Pulsar	0044
Quasar	0277, 0078, 0677
Quelle	0064, 0131, 0388, 0539
R-Line	0064
RCA	0074, 0027, 0057, 0205, 1474, 1481, 0117, 0119, 0706, 1074, 1174, 1274, 1374, 1574
RFT	0455
RadioShack	0074, 0181, 0207, 0057, 0205
Radiola	0064
Radiomarelli	0543
Realistic	0181, 0207, 0057, 0205
Rediffusion	0388
Reoc	0741
Revox	0064
Rex	0190, 0286, 0291
Roadstar	0036, 0291, 0445
Runco	0044, 0057, 0524, 0630
SBR	0064
SEG	0291, 0695
SEI	0543
SKY	0064
SSS	0207
Saba	0136, 0190, 0314, 0362
Saccs	0265
Sagem	0637
Saisho	0036, 0291, 0543
Salora	0190, 0383, 0388, 0575
Sambers	0543
Sampo	0181, 0120, 0057, 0205, 0198, 0036, 0119, 0677, 1782
Samsung	0181, 0087, 0839, 0729, 0057, 0205, 0036, 0064, 0117, 0119, 0291, 0397, 0583, 0614, 0645, 0793, 0841
Sansei	0478
Sansui	0490
Sanyo	0181, 0207, 0131, 0235, 0366, 0826
Schaub Lorenz	0388
Schneider	0064, 0274, 0398, 0695
Scotch	0205
Scott	0263, 0207, 0205
Sears	0074, 0081, 0181, 0183, 0205, 0198
Seleco	0190, 0286
Semivox	0207
Semp	0183
Sharp	0120, 0057, 0677
Shen Ying	0036, 0119
Sheng Chia	0120, 0263, 0036
Siarem	0543
Siemens	0064, 0222
Sinudnye	0543
Skantic	0383

TV	
Skygiant	0207
Skyworth	0064
Solavox	0190
Sonitron	0235
Sonoko	0036, 0064
Sonorlor	0190, 0235
Sontec	0064
Sony	1127, 0027, 0677, 0861, 1532, 1678
Soundesign	0207, 0205
Soundwave	0064, 0445
Sowa	0183, 0078, 0087, 0205, 0119
Squareview	0198
Standard	0036
Starlite	0207
Stern	0190, 0286
Supreme	0027
Sylvania	0081, 0057, 0198
Symphonic	0207, 0198
Synco	0027, 0478, 0120, 0087, 0205, 0119
Sysline	0064
T + A	0474
TCM	0835
TMK	0205
TNCi	0044
TVS	0490
Tacico	0205, 0036, 0119
Tai Yi	0036
Tandy	0120, 0190
Tashiko	0119, 0677
Tatung	0081, 0181, 0183, 0078, 0087, 0036, 0064, 0543
Teac	0036, 0064, 0291, 0439, 0445, 0482, 0695, 1064
Tec	0274
Technema	0347
Technics	0277, 0078, 0677
Techwood	0078
Teco	0078, 0120, 0205, 0036, 0119, 0291, 0680
Teknika	0081, 0207, 0177, 0087, 0119
Telefunken	0729, 0136, 0289, 0362, 0652
Telemeister	0347
Teletech	0036
Tensai	0347
Tera	0057
Thomson	1474, 0136, 0314, 0587, 0652
Thorn	0064, 0131, 0388, 0539
Toshiba	0181, 0183, 0087, 1283, 0535, 0645, 0677, 0859, 1383, 1683, 1731
Triumph	0543
Tuntex	0057, 0036, 0119
Uher	0347
Universum	0064, 0131, 0132, 0291, 0373, 0397, 0519
Vector Research	0057
Vestel	0064
Victor	0277, 0080, 0677, 0680
Videosat	0274
Vidikron	0081
Vidtech	0205
ViewSonic	1782
Vision	0347
Voxson	0190
Waltham	0383
Wards	0081, 0057, 0205, 0893

TV	
Watson	0064, 0347
Waycon	0183
White Westinghouse	0490, 0064, 0347, 0650
Yamaha	0057, 0796, 0860
Yapsh	0277
Yoko	0064, 0291
Zenith	0044, 0490, 0205, 0119

VCR Codes



VCR	
ASA	0064, 0108
Admiral	0075
Adventura	0027
Aiko	0305
Aiwa	0064, 0027, 0334, 0375, 0379
Akai	0068, 0342
Akiba	0099
Alba	0099, 0305, 0342, 0379
America Action	0305
American High	0062
Amstrad	0027
Anam	0064, 0267, 0305, 0253, 0507
Anam National	0253, 1589
Anitech	0099
Asha	0267
Asuka	0064
Audiovox	0064, 0305
Baird	0027, 0131, 0068
Basic Line	0099, 0305
Beaumarck	0267
Bell & Howell	0131
Blaupunkt	0253
Brandt	0347
Brandt Electronic	0068
Broksonic	0211, 0375, 1506
Bush	0099, 0305, 0379
CCE	0099, 0305
CGE	0027
Calix	0064
Canon	0062
Carver	0108
Cimline	0099
Cineral	0305
Citizen	0064, 0305, 1305
Colt	0099
Combitech	0379
Craig	0064, 0074, 0267, 0099
Crown	0099, 0305
Curtis Mathes	0087, 0062, 0068, 1062
Cybernex	0267
Cyrus	0108
Daewoo	0072, 0131, 0305, 0669, 1305
Dansai	0099
De Graaf	0069
Decca	0108, 0027
Denon	0069
Dual	0068
Dumont	0108, 0027, 0131
Dynatech	0027
ESC	0267, 0305
Elcatech	0099
Electrohome	0064
Electroponic	0064
Emerex	0059
Emerson	0062, 0064, 0211, 0267, 0072, 0027, 0070, 0305, 1305, 1506

VCR	
Ferguson	0068, 0347
Fidelity	0027
Finlandia	0108, 0131
Finlux	0108, 0027, 0069, 0131
Firstline	0064, 0072, 0070, 0099
Fisher	0074, 0131
Fuji	0062, 0060
Fujitsu	0072, 0027
Funai	0027
GE	0087, 0062, 0267, 0834, 1062, 1087
GEC	0108
Garrard	0027
General	0072
Go Video	0459
GoldHand	0099
GoldStar	0064, 0252, 0507, 1264
Goodmans	0064, 0027, 0099, 0305
Gradiente	0027
Graetz	0267, 0131, 0068
Granada	0108, 0131
Grandin	0064, 0027, 0099
Grundig	0108, 0099, 0253, 0374
HCM	0099
HI-Q	0074
Hanseatic	0064
Harley Davidson	0027
Harman/Kardon	0108
Harwood	0099
Hinari	0267, 0099, 0379
Hitachi	0064, 0267, 0027, 0069, 0068
Hughes Network Systems	0069
Hypson	0099
ITT	0267, 0131, 0068
ITV	0064, 0305
Imperial	0027
Interfunk	0108
JVC	0072, 0094, 0068
Jensen	0068
KEC	0064, 0305
KLH	0099
Kaisui	0099
Kenwood	0094, 0068
Kodak	0062, 0064
Kolin	0070, 0068
Korpel	0099
LG	0064, 0072, 0069, 0507
LXI	0064
Lenco	0305
Leyco	0099
Lloyd's	0027
Loewe	0064, 0108, 1589
Logik	0267, 0099
Luxor	0075, 0131, 0070
M Electronic	0027
MEI	0062
MGA	0267, 0070
MGN Technology	0267
MTC	0267, 0027
Magnasonic	1305
Magnavox	0062, 0066, 0108, 0027, 1808
Magnin	0267
Manesth	0072, 0099
Marantz	0062, 0108
Marta	0064
Matsui	0375, 0379
Matsushita	0062
Medion	0375

VCR	
Memorex	0062, 0064, 0075, 0066, 0074, 0267, 0027, 0131, 0334, 0375, 1264
Memphis	0099
Metz	0064, 0374, 1589
Minolta	0069
Mitsubishi	0108, 0094, 0070, 0068, 0834
Motorola	0062, 0075
Multitech	0027, 0099
Murphy	0027
Myriad	0108
NAD	0131
NEC	0062, 0064, 0075, 0131, 0094, 0068
National	0253
Neckermann	0108
Nesco	0099
Newave	0064
Nikko	0064
Noblex	0267
Nokia	0267, 0131, 0068
Nordmende	0068, 0347
Oceanic	0027, 0068
Okano	0342, 0375
Olympus	0062, 0253
Optimus	0064, 0075, 0131, 0459
Orion	0211, 0375, 0379, 1506
Osaki	0064, 0027, 0099
Otto Versand	0108
Palladium	0064, 0068, 0099
Panasonic	0062, 0252, 0253, 0643, 1062, 1589
Pathe Marconi	0068
Penney	0062, 0064, 0267, 0069, 1062, 1264
Pentax	0069
Perdio	0027
Philco	0062
Philips	0062, 0108, 0645, 1108, 1208
Phonola	0108
Pilot	0064
Pioneer	0108, 0069, 0094
Polk Audio	0108
Profftronic	0267
Proline	0027
Proscan	0087, 1087
Protec	0099
Pulsar	0066
Pye	0108
Quasar	0062, 1062
Quelle	0108
RCA	0087, 0062, 0267, 0069, 0834, 1062, 1087
RadioShack	0027
Radiola	0108
Radix	0064
Randex	0064
Realistic	0062, 0064, 0075, 0074, 0027, 0131
Reoc	0375
ReplayTV	0641, 0643
Rex	0068
Roadstar	0064, 0267, 0099, 0305
Runco	0066
SBR	0108
SEG	0267
SEI	0108
STS	0069
Saba	0068, 0347
Salora	0070
Sampo	0064, 0075
Samsung	0267, 0072, 0459
Sanky	0075, 0066

VCR	
Sansui	0027, 0094, 0068, 1506
Sanyo	0074, 0267, 0131
Saville	0379
Schaub Lorenz	0027, 0131, 0068
Schneider	0108, 0027, 0099
Scott	0211, 0072, 0070
Sears	0062, 0064, 0074, 0027, 0069, 0131, 1264
Seleco	0068
Semp	0072
Sharp	0075, 0834
Shintom	0131, 0099
Shogun	0267
Siemens	0064, 0108, 0131
Silva	0064
Singer	0072, 0099
Sinudyne	0108
Sonic Blue	0641, 0643
Sontec	0064
Sony	0062, 0059, 0060, 0027, 0663, 1259
Sunkai	0375
Sunstar	0027
Suntronic	0027
Sylvania	0062, 0108, 0027, 0070, 1808
Symphonic	0027
TMK	0267
Tandy	0027, 0131
Tashiko	0064, 0027
Tatung	0108, 0072, 0027, 0094, 0068
Teac	0027, 0068, 0305, 0334, 0669
Technics	0062, 0253
Teco	0062, 0064, 0075, 0068
Teknika	0062, 0064, 0027
Teleavia	0068
Telefunken	0068, 0347
Tenosal	0099
Tensai	0027
Thomas	0027
Thomson	0087, 0094, 0068, 0347
Thorn	0131, 0068
Tivo	0645, 0663
Toshiba	0108, 0072, 0094, 0070, 0068, 0872
Totevision	0064, 0267
Uher	0267
Unitech	0267
Universum	0064, 0108, 0267, 0027
Vector	0072
Victor	0094, 0068
Video Concepts	0072
Videomagic	0064
Videosonic	0267
Villain	0027
Wards	0087, 0062, 0075, 0074, 0108, 0267, 0027, 0069, 0099
White Westinghouse	0099
XR-1000	0062, 0027, 0099
Yamaha	0068
Yamishi	0099
Yokan	0099
Yoko	0267
Zenith	0066, 0060, 0027, 1506

CABLE/CDR Codes



CD Recorder	
Onkyo	6005, 6006 (RI)

CABLE	
ABC	0030, 0035
Americast	0926
Bell South	0926
Birmingham Cable Communications	0303
British Telecom	0030
Cable & Wireless	1095
Daeryung	0904, 1904, 0504, 0035
Director	0503
Filmnet	0470
General Instrument	0503, 0837, 0303, 0030
GoldStar	0171
Hamlin	0036, 0300
Jerrold	0503, 0837, 0303, 0030
LG	0171
MNet	0470
Memorex	0027
Motorola	0503, 0837, 0303, 1133
NTL	1095
Noos	0844
Ono	1095
PVP Stereo Visual Matrix	0030
Pace	0264, 1087, 1095
Panasonic	0027, 0035, 0134
Paragon	0027
Philips	0332, 0344
Pioneer	0904, 1904, 0171, 0560
Pulsar	0027
Quasar	0027
Regal	0306, 0300
Runco	0027
Sagem	0844
Samsung	0027, 0171
Scientific Atlanta	0904, 1904, 0504, 0035
Sony	1033
Starcom	0030
Supercable	0303
TS	0030
Tele+1	0470
Telewest	1095
Torx	0030
Toshiba	0027
Trans PX	0303
United Cable	0030
Zenith	0027, 0552, 0926

SAT/MD Codes



MD Recorder	
Onkyo	6007, 6008 (RI)

Satellite	
@sat	1327
ABsat	0150
Alba	0482
AlphaStar	0799
Amstrad	0874
Aston	0169, 1156
Astro	0200
Atsat	1327
Avalon	0423
Blaupunkt	0200
British Sky Broadcasting	0874, 1202
Canal Digital	0880
Canal Satellite	0880
Canal+	0880
Chaparral	0243
Citycom	1203
Connexions	0423
Crossdigital	1136
Cyrus	0227
D-box	0750, 1154
DMT	1102
DNT	0227, 0423
Daeryung	0423
Daewoo	1323
Digenius	0326
DirecTV	0419, 0593, 0666, 1169, 0274, 0776, 1776, 0751, 0846, 1883, 1103, 1136
Dish Network System	1032, 0802
DishPro	1032, 0802
Distratel	0111
Dream Multimedia	1264
EchoStar	1032, 0802, 0194, 0423, 0637, 0880, 0898, 1113
Engel	1044
Expressvu	0802
FTE	0890
Finlux	0482
Fracarro	0898
Fuba	0423
GE	0593
GOI	0802
Galaxis	0890, 1138
General Instrument	0896
Gold Box	0880
Grundig	0200, 0874
HTS	0802
Hirschmann	0200, 0423
Hitachi	0846, 0482
Hughes Network Systems	1169, 0776, 1776
Humax	0890, 1203
InVideo	0898
JVC	0802
Kathrein	0150, 0200, 0227, 0276, 0685, 1248
Kreiselmeier	0200

Satellite	
Labgear	1323
Logix	1044
Lorenzen	0326
Magnavox	0751, 0749
Manhattan	0482, 1044, 1110
Marantz	0227
MediaSat	0880
Memorex	0751
Metronic	0111
Mitsubishi	0776
Motorola	0896
Myryad	0227
Next Level	0896
Nokia	0482, 0750, 0778, 1154, 1250, 1750
OctalTV	1032
Orbitech	1127
Pace	0482, 0874, 1202, 1350
Panasonic	0274, 0728, 0874, 1347
Panda	0482
Paysat	0751
Philips	1169, 0776, 1776, 0751, 1103, 0749, 0160, 0227, 0482, 0880
Pioneer	0880
Promax	0482
Proscan	0419, 0593
RCA	0419, 0593, 0882, 0170
RFT	0227
RadioShack	0896
Radiola	0227
Radix	0423
SKY	0883, 0874, 1202
SM Electronic	1227
Sabre	0482
Sagem	0847, 1141, 1280
Samsung	1303, 1136, 1044, 1319
Sat Control	1327
Satstation	1110
Schwaiger	1138
Seemann	0423
Siemens	0200
Sony	0666, 1666, 0874
Star Choice	0896
Strong	1327
TPS	0847, 1280
Tantec	0482
TechniSat	1126, 1127
Telestar	1127
Thomson	0482, 0880, 1073, 1318
Topfield	1233
Toshiba	0776, 1776, 0817
UltimateTV	0419, 0666
Uniden	0751, 0749
Universum	0200
Ventana	0227
Wisi	0200, 0423, 0482
XSat	0150
Zehnder	1102
Zenith	0883, 1883



ONKYO
IMAGINATIVE SIGHT & SOUND

Do more with your iPod

DS-A1 Remote Interactive Dock for iPod

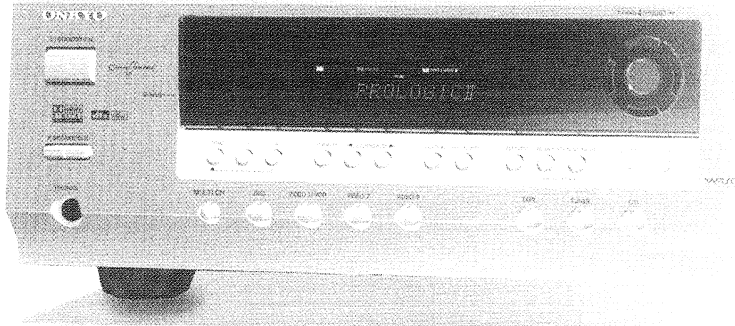
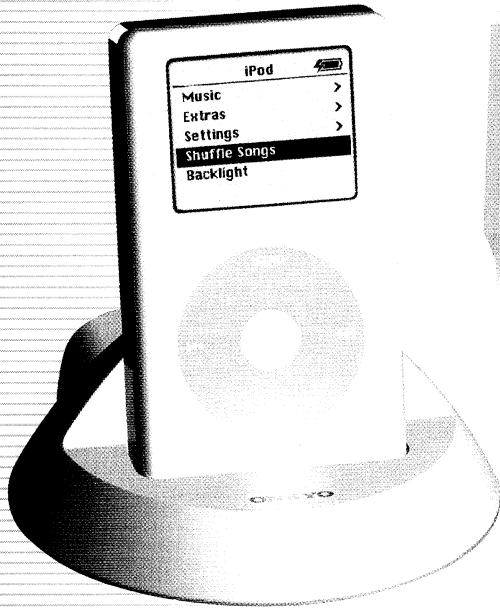

- iPod Cradle for Onkyo Components and System
- Charges iPod
- RCA Stereo Audio Output
- Video Output for iPod Photo Slide Show
- Control your iPod using your Onkyo remote

Available June 2005

AUDIO / PHOTO



CONTROL



CHARGE



RI (Remote Interactive)

Control your music from your RI remote

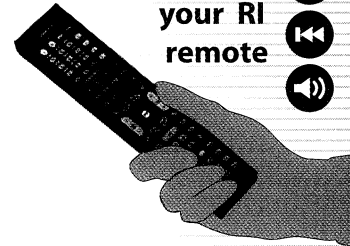

For iPod, iPod mini and iPod photo

4th Generation iPod with Click Wheel or 3rd Generation iPod with touch wheel and buttons

Download from www.Somanuals.com. All Manuals Search And Download.

For More Information:

visit www.onkyousa.com



SATELLITE
RADIO

Your New System is XM Ready®

Getting XM Couldn't Be Simpler!



XM 
CONNECT & PLAY™

The Only Accessory You Need to Get XM

Your New System is XM Ready®

Experience the Next Generation of Radio

You have made one of the wisest purchasing decisions you could make by selecting an XM Ready audio system. Millions of Americans have chosen XM Satellite Radio as their preferred audio entertainment format and now you can too! Adding XM's award-winning content and amazing sound quality to your new audio system couldn't be simpler. All you need to do is buy the optional XM Connect & Play antenna, connect it to your system and subscribe to XM's critically acclaimed service. It's that simple. No additional accessories. No more wires. Nothing. One simple antenna. One simple phone call. That's it. Make the most of your audio system by adding XM Connect & Play today.

XM
CONNECT & PLAY™

Not Just a Satellite Radio Antenna.
XM Connect & Play not only receives XM's signal, but also features an integrated XM tuner. It's the only accessory needed to receive XM through an XM Ready home audio system.

Only **\$49⁹⁹**



CNP-1000

Order Today!

- Log on to www.xmradio.com/xmcp or call toll-free **1-888-944-3896**.
- XM Connect & Play is also available wherever XM Ready home products are sold.
- Required XM monthly subscription (\$12.95/month) sold separately. Tax and shipping charges may apply.

"...the closest you can come nowadays to going to Radio Heaven."

The New York Times

"For musicheads, XM is the superior product."

The Miami Herald



ROCK HITS COUNTRY POP SOUL DANCE LATIN JAZZ HIP-HOP

BEST RADIO SERVICE



America's #1 Satellite Radio Service



100% Commercial-Free Music

XM has the most commercial-free music in satellite radio, with channels dedicated to virtually every music genre.

So now you can enjoy more of the music you love without commercial interruption. And every music channel is an exclusive original — produced at XM studios and featuring specials, live performances, rare recordings and inside information that you won't hear anywhere else.

The Most Sports Play-by-Play

XM has the most sports play-by-play on satellite radio, including exclusive coverage of Major League Baseball,[®] NASCAR,[®] PGA TOUR,[®] IndyCar[®] Racing and World Cup[™] Soccer. Plus, NFL and NBA scores and analysis on ESPN Radio, FOX Sports Radio and Sporting News Radio. There's even exciting college sports action on dedicated XM channels for the ACC, Big Ten and Pac-10 football and basketball, plus college football action across the country, including the Bowl Championship Series, on ESPN Radio.



News and Talk All-Stars

XM has the biggest names in news and talk, including FOX News Channel, CNN, CNN Headline News, CNBC, MSNBC, ABC News & Talk and BBC World Service. And XM offers XM Public Radio[™] featuring the exclusive Bob Edwards Show, hosted by award-winning journalist Bob Edwards. Plus talk radio stars Opie & Anthony, Dr. Laura, G. Gordon Liddy, Tony Kornheiser and more.

Superior Digital Sound Quality — The Best in Satellite Radio

The March 2005 issue of *Smart Money* magazine said that XM Satellite Radio has better sound quality than the other satellite radio service. Only XM combines aacPlus by Coding Technologies with Neural Audio optimization to achieve digital-quality sound remarkably close to Compact Disc.

"The HBO of satellite radio."

Fortune

"I've found the place where rock & roll has gone to have its final party..."

Stephen King, Entertainment Weekly

BLUES KIDS NEWS REGGAE CLASSICAL TALK SPORTS TRAFFIC WEATHER

america's largest playlist Over 150 Digital Channels Coast to Coast

MUSIC THE MOST 100% COMMERCIAL-FREE CHANNELS

DECADES

- 4 BIG BAND/SWING/FORTIES
- 5 FIFTIES HITS
- 6 SIXTIES HITS
- 7 SEVENTIES HITS
- 8 EIGHTIES HITS
- 9 NINETIES HITS

COUNTRY

- 10 CLASSIC COUNTRY
- 11 90s & TODAY'S COUNTRY
- 12 PROGRESSIVE COUNTRY
- 13 TRADITIONAL COUNTRY
- 14 BLUEGRASS
- 15 FOLK
- 16 TOP COUNTRY HITS

POP & HITS

- 20 TOP 20 HITS
- 21 TODAY'S HIT MUSIC
- 22 MODERN POP HITS
- 23 LOVE SONGS
- 24 BEAUTIFUL MUSIC
- 25 ADULT HITS - PAST & TODAY
- 27 MOVIE SOUNDTRACKS
- 28 SHOW TUNES
- 29 EURO & GLOBAL CHART HITS

CHRISTIAN

- 31 CHRISTIAN ROCK
- 32 CHRISTIAN POP
- 33 GOSPEL

ROCK

- 40 DEEP ALBUM ROCK
- 41 HARD ROCK XL
- 43 COLLEGE/INDIE/NEW MUSIC
- 44 DEEP CLASSIC ALTERNATIVE
- 45 SOFT ALTERNATIVE
- 46 CLASSIC ROCK
- 47 90s & TODAY'S ALTERNATIVE
- 48 HARD ALTERNATIVE XL
- 50 ACOUSTIC ROCK
- 51 JAMBANDS/PROG ROCK
- 52 UNSIGNED ARTISTS
- 53 PUNK/HARDCORE/SKA XL
- 54 ALTERNATIVE HITS

HIP-HOP & URBAN

- 60 CLASSICAL SOUL
- 61 NEO SOUL
- 62 TODAY'S R&B
- 64 OLD SCHOOL R&B
- 65 CLASSIC HIP-HOP/RAP XL
- 66 UNCUT HIP-HOP XL
- 67 URBAN TOP 40

JAZZ & BLUES

- 70 TRADITIONAL JAZZ
- 71 CONTEMPORARY JAZZ
- 72 MODERN JAZZ
- 73 AMERICAN STANDARDS
- 74 BLUES

LIFESTYLE

- 75 THE VOICE OF MUSIC AT STARBUCKS
- 76 ECCLECTIC
- 77 NEW AGE

DANCE

- 80 UNDERGROUND DANCE
- 81 DANCE HITS
- 82 ELECTRONICA
- 83 DISCO

LATIN

- 90 LATIN HITS
- 92 REGIONAL MEXICAN
- 94 TROPICAL
- 95 LATIN JAZZ

WORLD

- 100 WORLD
- 101 REGGAE
- 102 AFRICAN

CLASSICAL

- 110 TRADITIONAL CLASSICAL
- 112 OPERA/CLASSICAL VOCALS
- 113 POPULAR CLASSICAL



The XM basic monthly subscription includes XM Radio Online. Stream all commercial-free music channels, High Voltage, The Bob Edwards Show, comedy, kids programming and more. Visit xmradio.com for details.

NEWS THE BIGGEST NAMES IN NEWS & INFORMATION

- | | | | |
|------------------------|--------------------------|------------------------|--------------------------------------|
| 121 FOX NEWS | 125 THE WEATHER CHANNEL | 131 BBC WORLD SERVICE | C-SPAN RADIO |
| 122 CNN | 127 CNBC | 132 C-SPAN RADIO | THE BOB EDWARDS SHOW, PRL,APM & WEBL |
| 123 CNN HEADLINE NEWS | 129 BLOOMBERG RADIO | 133 XM PUBLIC RADIO | CNN EN ESPAÑOL |
| 124 ABC NEWS & TALK | 130 MSNBC | 134 CNN | |

SPORTS THE MOST PLAY-BY-PLAY ON SATELLITE RADIO

- | | | |
|-------------------------------|---|--------------------------------------|
| 140 SPORTS TALK/PLAY-BY-PLAY | 145 IN-RACE DRIVER AUDIO | 190 PLAY-BY-PLAY EN ESPAÑOL |
| 141 SPORTS NEWS | 146 THE PGA TOUR NETWORK/LIVE COVERAGE & GOLF TALK | 191-193 ACC FOOTBALL/BASKETBALL |
| 142 SPORTS TALK | 147 PLAY-BY-PLAY EN ESPAÑOL/WORLD CUP SOCCER | 194-196 PAC-10 FOOTBALL/BASKETBALL |
| 143 SPORTS TALK | 175 MLB HOME PLATE 24/7 MLB NEWS & TALK | 197-199 BIG TEN FOOTBALL/BASKETBALL |
| 144 24/7 NASCAR RACING/TALK | 176-189 14 MAJOR LEAGUE BASEBALL PLAY-BY-PLAY CHANNELS | |

KIDS AWARD-WINNING CHILDREN'S PROGRAMMING

- | | |
|---------------|---------------|
| 115 CHILDREN | 116 CHILDREN |
|---------------|---------------|

TALK COMEDY & ENTERTAINMENT

- | | | |
|----------------------|------------------------|--|
| 150 COMEDY XL | 162 E! ENTERTAINMENT | 169 AFRICAN-AMERICAN TALK |
| 151 FAMILY COMEDY | 163 BOOKS & DRAMA | 170 CHRISTIAN TALK |
| 152 EXTREME TALK | 164 OLD TIME RADIO | 171 TRUCKERS' CHANNEL |
| 155 MTV RADIO | 165 EXPERTS & ADVICE | 200 CONCERTS/FESTIVALS/SPECIAL FEATURES |
| 156 VH1 RADIO | 166 CONSERVATIVE TALK | 202 OPE & ANTHONY SHOW XL |
| 161 DISCOVERY RADIO | 167 PROGRESSIVE TALK | |

TRAFFIC & WEATHER

- | | | | | |
|----------------------|------------------------------|---------------------|------------------------------|------------------------------|
| 210 BOSTON, MA | 215 PITTSBURGH, PA | 220 SEATTLE, WA | 225 DALLAS/FORT WORTH, TX | 230 MIAMI/FT. LAUDERDALE, FL |
| 211 NEW YORK, NY | 216 DETROIT, MI | 221 HOUSTON, TX | 226 HOUSTON, TX | |
| 212 PHILADELPHIA, PA | 217 CHICAGO, IL | 222 LOS ANGELES, CA | 227 ATLANTA, GA | 247 XM EMERGENCY ALERT |
| 213 BALTIMORE, MD | 218 ST. LOUIS, MO | 223 SAN DIEGO, CA | 228 TAMPA/ST. PETERSBURG, FL | |
| 214 WASHINGTON, DC | 219 MINNEAPOLIS/ST. PAUL, MN | 224 PHOENIX, AZ | 229 ORLANDO, FL | powered by |

PREMIUM

- 205 ADULT XL Additional \$2.99/month

- XM Previews on Channel 1
- May include frequent explicit language.
- Please call XM Listener Care at 1-800-XM-RADIO (1-800-667-7266) for Parental Control/Blocking Option.
- Ch. 129 airs SAM ET-6PM ET Mon-Fri.
- Ch. 143 may be preempted between 9AM ET-9PM ET Sat & Sun.
- Ch. 180 airs 6PM ET-5AM ET weekdays and all day Sat & Sun.

- Visit nascar2xmradio.com for NASCAR 2 Ch. 145 broadcast schedule. Visit collegeports.xmradio.com for college game schedules. Games subject to availability. Spanish Sports Ch. 147 begins July 2005.
- All schedules subject to change.
- Visit xmradio.com for Ch. 200 special event dates and times.

Channel lineup effective 6/10/05 - All programming subject to change. Visit xmradio.com for updates. ©2005 XM Satellite Radio.

Hardware and required \$12.95 basic monthly subscription sold separately. XM Connect & Play™ antenna required to receive XM service (sold separately). Premium Channel available at additional monthly cost. Installation costs and other fees and taxes, including a one-time activation fee may apply. Subscription fee is consumer only. All fees and programming subject to change. Channels with frequent explicit language are indicated with an XL. Channel blocking is available for XM radio receivers by calling 1-800-XM-RADIO. Subscriptions subject to Customer Agreement available at xmradio.com. Only available in the 48 contiguous United States. XM Connect & Play™, XM Ready™ and XM Public Radio™ are trademarks of XM Satellite Radio Inc. ©2005 XM Satellite Radio Inc. All rights reserved. All other trademarks are the property of their respective owners.

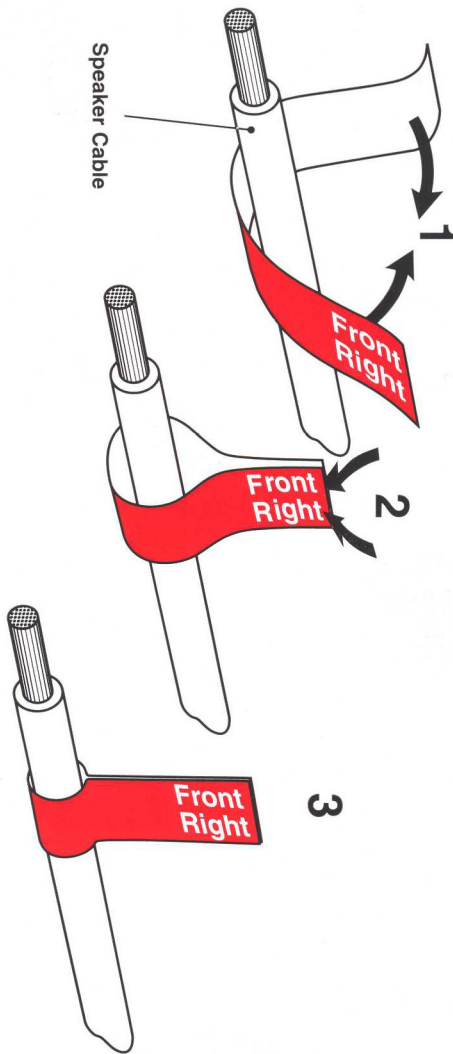

Front Left	Front Left
Front Left	Front Left
SP-B/Zone 2 Left	SP-B/Zone 2 Left
SP-B/Zone 2 Left	SP-B/Zone 2 Left

Front Right	Front Right
Front Right	Front Right
SP-B/Zone 2 Right	SP-B/Zone 2 Right
SP-B/Zone 2 Right	SP-B/Zone 2 Right

Surround Left	Surround Left
Surround Left	Surround Left

Surround Right	Surround Right
Surround Right	Surround Right

Center	Center
Center	Center

Surround Back Left	Surround Back Left
Surround Back Left	Surround Back Left
Zone 2 Left	Zone 2 Left
Zone 2 Left	Zone 2 Left

Surround Back Right	Surround Back Right
Surround Back Right	Surround Back Right
Zone 2 Right	Zone 2 Right
Zone 2 Right	Zone 2 Right

We offer Product Support/Customer Service 7 days per week

In order to better assist you with your purchase, Onkyo has extended its customer service hours to a seven-day schedule. For questions, assistance, or comments Please call or e-mail us at :

Phone: 1-800-229-1687

E-mail: Onkyo@onkyousa.com

For information concerning product features and hookups, please include your name and daytime phone number along with the model number you are inquiring about for a response from a product specialist.

Hours of Operation:

Mon – Fri 9:00am – 8pm (Eastern Standard Time)

Sat – Sun 10:00am – 4pm (Eastern Standard Time)

OBTAINING WARRANTY SERVICE:

To obtain warranty service, take or ship your Onkyo product to an Onkyo authorized service center, together with a note describing your complaint and your copy of the dated purchase receipt. If you choose to ship your Onkyo product to an Onkyo authorized service center, all shipping arrangement must be made by you and all shipping charges and insurance must be fully prepaid. Any Onkyo product shipped in its entirety must be shipped in its original carton. Onkyo will pay all return shipping charges for Onkyo products that have been serviced under this warranty.

ONKYO Product REGISTRATION CARD

Thank you for purchasing our product. In order to protect your investment and to ensure that you receive information on new products, future updates or new releases, please register your product. You have two ways to do it.

- Quick and Easy -

Please visit our web site for your on-line registration at

<http://www.onkyousa.com>

Or please fill out this registration card and return it to us. Please remember to keep your receipt of your purchase for warranty and the other part of this card for future reference.

First Name _____ Middle Initial _____ Last Name _____

Address _____ Apt/Suite _____

City _____ State _____ Zip _____

E-mail Address _____ Phone Number _____

Age: 18 - 24 25 - 31 32 - 40 41 - 60 61 + Male Female

Name and location of the Dealer you purchased the product from? _____

Date of Purchase _____ Model _____ Serial Number _____

Would you like to receive a product catalog every new model year?

Yes No

How did you learn about Onkyo Products?

Advertisement Review Salesman Friend Other

Do you own other Onkyo Products? _____ If yes, what is the model number _____

Yes No

What other brands of stereo products or multi media products have you owned before? _____

What factors influenced your purchase decision?

Features Sound Quality Design Price Recommendation

What other Audio/Video/multi media Equipment are you looking to purchase in the future? _____

When do you plan to purchase your next audio or multi media product?

3 Months 6 Months 9 Months 12 Months 24 Months

Other Comments/Suggestions about this product _____

ONKYO USA CORPORATION

18 Park Way
Upper Saddle River, NJ 07458 USA
Phone: 201-785-2600
Fax : 201-785-2650
<http://www.onkyousa.com>

Onkyo USA Limited Warranty

PLEASE RETAIN YOUR ORIGINAL BILL OF SALE. YOU WILL NEED TO PRESENT IT SHOULD YOU REQUIRE SERVICE UNDER THIS WARRANTY.

Onkyo USA Corporation (hereinafter referred to as Onkyo) hereby warrants all Onkyo products sold by Onkyo or Onkyo authorized dealers in accordance with the following terms and conditions:

WARRANTY PERIOD:

Receivers and Amplifiers	2 years Parts & labor
Home Theater Speakers	2 years Parts & labor
CD, DVD Players & Tape Decks	1 year Parts & labor
CD, DVD Receivers	1 year Parts & labor
Mini Systems	1 year Parts & labor
Multimedia & Audio/Video Accessories	1 year Parts & labor

SCOPE OF WARRANTY:

From the date of original purchase and for the respective periods specified above, Onkyo agrees to repair at its sole expense, all Onkyo products purchased directly from Onkyo or an Onkyo Authorized Dealer, which are defective in material and/or workmanship.

EXCLUSIONS:

This Warranty does not apply with respect to the following:

1. Defects or damage caused by accident, fire, flood, lightning or other acts of nature.
2. Defects or damage caused by abuse, misuse, negligence or failure to observe the instructions contained in the manual furnished at the time of original purchase.

Onkyo USA Limited Warranty

PLEASE RETAIN YOUR ORIGINAL BILL OF SALE. YOU WILL NEED TO PRESENT IT SHOULD YOU REQUIRE SERVICE UNDER THIS WARRANTY.

Onkyo USA Corporation (hereinafter referred to as Onkyo) hereby warrants all Onkyo products sold by Onkyo or Onkyo authorized dealers in accordance with the following terms and conditions:

WARRANTY PERIOD:

Receivers and Amplifiers	2 years Parts & labor
Home Theater Speakers	2 years Parts & labor
CD, DVD Players & Tape Decks	1 year Parts & labor
CD, DVD Receivers	1 year Parts & labor
Mini Systems	1 year Parts & labor
Multimedia & Audio/Video Accessories	1 year Parts & labor

SCOPE OF WARRANTY:

From the date of original purchase and for the respective periods specified above, Onkyo agrees to repair at its sole expense, all Onkyo products purchased directly from Onkyo or an Onkyo Authorized Dealer, which are defective in material and/or workmanship.

EXCLUSIONS:

This Warranty does not apply with respect to the following:

1. Defects or damage caused by accident, fire, flood, lightning or other acts of nature.
2. Defects or damage caused by abuse, misuse, negligence or failure to observe the instructions contained in the manual furnished at the time of original purchase.
3. Damage caused during shipment or handling.
4. Products purchased from anyone other than Onkyo or an Onkyo Authorized Dealer. If you are uncertain as to whether a dealer is authorized, please contact Onkyo's Customer Service Department or check the Dealer and Service Locator at our web site: <http://www.Onkyousa.com>
5. Products that have had their serial numbers altered or removed.
6. Products purchased in 'AS IS' condition.
7. Products that have been altered or repaired by anyone other than Onkyo or an Onkyo authorized service center in a manner that has affected their performance, stability or reliability.
8. Accessories attached to or to be used with Onkyo products, such as antennas, cables, etc.
9. Packing materials, batteries, antennas & cosmetic items.
10. Parts which have prescribed useful lives dependent upon the degree of their use, such as stylus, cassette heads, idler wheels, etc.
11. Installation & removal of Onkyo products.
12. Maintenance, cleaning or periodic check-ups.
13. Adjustments or alteration required for compatibility with conditions pertaining to foreign countries.
14. Products used continuously or for commercial applications. Onkyo products are intended for consumers' use and are not designed for continuous or commercial use. In the event that the products concerned have been used commercially or continuously, the warranty period is limited to 90 days from the date of purchase.

LIMITATIONS:

Onkyo makes this warranty subject to the following limitations:

1. This Warranty is valid only within the territory of the United States of America. To be covered by this warranty the Onkyo product concerned must have been originally purchased and the person seeking warranty service must reside in one of the states of the United States of America or in the District of Columbia.
2. ONKYO SHALL HAVE NO LIABILITY WHATSOEVER FOR INCIDENTAL OR CONSEQUENTIAL DAMAGES. THE RESPONSIBILITY OF ONKYO UNDER THIS WARRANTY SHALL BE LIMITED TO THE REPAIR OF DEFECTIVE ONKYO PRODUCTS BY ONKYO OR ITS AUTHORIZED SERVICE CENTERS.
3. This warranty is valid only with respect to repairs effected by Onkyo or an Onkyo authorized service center.
4. ALL WARRANTIES OTHER THAN THE EXPRESS WARRANTY HEREIN CONTAINED INCLUDING BUT NOT LIMITED TO ANY IMPLIED WARRANTY OF MERCHANTABILITY OR FITNESS FOR A PARTICULAR PURPOSE ARE LIMITED IN DURATION TO THE APPLICABLE WARRANTY PERIOD SET FORTH ABOVE.

Some states do not allow limitations on how long an implied warranty lasts and some states do not allow the exclusion or limitation of incidental or consequential damages, so the above limitations or exclusion may not apply to you. This warranty gives you specific legal rights and you may also have other rights that vary from state to state.

Model _____

Serial No. _____

Customer's Name _____

Dealer's Name _____

Date of Purchase _____

ONKYO USA CORPORATION

18 Park Way
Upper Saddle River, NJ 07458 USA

Phone: 201-785-2600
Fax : 201-785-2650
<http://www.onkyousa.com>

SN. 29365090C

POST OFFICE
WILL NOT
DELIVER
WITHOUT
PROPER POSTAGE

REGISTRATION DEPARTMENT

ONKYO USA CORPORATION

18 PARK WAY
UPPER SADDLE RIVER, NJ 07458 USA

ONKYO®

Tape here

Free Manuals Download Website

<http://myh66.com>

<http://usermanuals.us>

<http://www.somanuals.com>

<http://www.4manuals.cc>

<http://www.manual-lib.com>

<http://www.404manual.com>

<http://www.luxmanual.com>

<http://aubethermostatmanual.com>

Golf course search by state

<http://golfingnear.com>

Email search by domain

<http://emailbydomain.com>

Auto manuals search

<http://auto.somanuals.com>

TV manuals search

<http://tv.somanuals.com>