

# ORECK<sup>®</sup> XL<sup>®</sup>

SIMPLY AMAZING<sup>®</sup>

## Service Manual



Table Top Air Cleaner  
Super Air 5 / Air 6  
Model 447628 & 447880

REV 1., Please disregard all earlier versions.



# Important Safeguards

---

When using electrical appliances consideration should be given to basic safety precautions including:

1. Read all instructions.
2. Do not immerse appliance, cord or plug in water or other liquid and take care to ensure that the control panel is kept clean and dry.
3. Do not use the appliance if there is any visible damage to the appliance or to the supply cord.
4. Close supervision is necessary when any appliance is used by or near children.
5. Do not let the cord hang over the edge of the table or worktop or touch hot surfaces.
6. Do not use the appliance outdoors.
7. Do not use the appliance for other than its intended use.
8. **WARNING:** DO NOT USE THIS ELECTRONIC AIR CLEANER WHEN OXYGEN IS BEING USED OR WHEN COMBUSTIBLE GASES ARE PRESENT. HIGH VOLTAGE SPARKS CAN CAUSE IGNITION AND SUBSEQUENT PERSONAL INJURY OR PROPERTY DAMAGE.
9. **NOTE:** Care should be taken to avoid touching the sharp ionizer needle situated above the fan. Always disconnect the unit from power prior to cleaning or servicing.



**General Knowledge Warning** - The intent of this manual is to provide general guidance to be used by a qualified service technician in servicing the Oreck tabletop electrostatic air cleaner. The technician should have a good understanding relative to working with electrical and mechanical equipment. A knowledge base to include basic electronics, basics of motors and general mechanical knowledge is required to service this equipment. Attempting to service the equipment without the above background could result in electric shock, personal injury or property damage. Do not attempt to service equipment unless properly qualified.



**Rotating Element Warning** - Unit has a rotating blower wheel and cooling fan to circulate air and keep the unit cool. When servicing the unit and repairing the unit always insure that you keep objects and internal electrical wiring away from the rotating elements. Failure to allow for proper clearance for rotating members can cause electric shock, personal injury or property damage.

## Tools Required

Multimeter Fluke Model	8024-B
High Voltage Probe Fluke Model	80K-40
#2 Flat Blade Screwdriver	
#2 Phillips Drive Screwdriver	
Diagonal Wire Cutters	
Wire nuts	
Needlenose Pliers	

# Table of Contents

---

General Description and Operation .....	page 3
Periodic Maintenance and Tune-Up .....	page 4
Trouble Shooting Guide .....	page 5
Parts Removal and Replacement Procedures .....	page 15
Cross Section and Parts List .....	page 25
Wiring Diagram .....	page 26

## General Description and Operation

---



Airborne particles and odors are removed from air passing through the unit by the process of electrostatic precipitation and the revolutionary post filter which combines antimicrobial treatment and activated charcoal.

The air around you is filled with thousands of particles of air pollution. Some of the pollutants - dust, pollen and lint are visible to the naked eye, but most of the pollutants - smoke and bacteria, to name a few, are microscopic in size.

Polluted air enters the unit through the front of the air cleaner. The fan pulls in dirty air and the pre-filter traps large particles (hair, lint, etc.). The smaller particles (dust, smoke, pollen) in the dirty air receive a positive electrical charge as they pass through the ionizing section. The positive charged particles then enter the collecting section which uses a series of alternately charged aluminum plates to attract and retain the particles. It works like a powerful magnet and the particles remain there through natural adhesion until removed by the washing process. The air then passes through the post filter that helps control microorganisms and remove household odors. Next, the negative ion generator freshens stale air. Finally, clean air passes back into the room through the top grille.

# Periodic Maintenance Tune-Up

---

1. Remove collecting cell and pre/post filters.
2. Wipe down inside of unit with damp cloth.
3. Thoroughly Clean Collecting Cell with Oreck Assail-A-Cell Cleaner.
4. Check for any broken wires in the collecting cell, and ensure wires are securely seated in the plastic spacer at the center of the cell. Check for any bent plates in collecting cell. Replace if damaged.

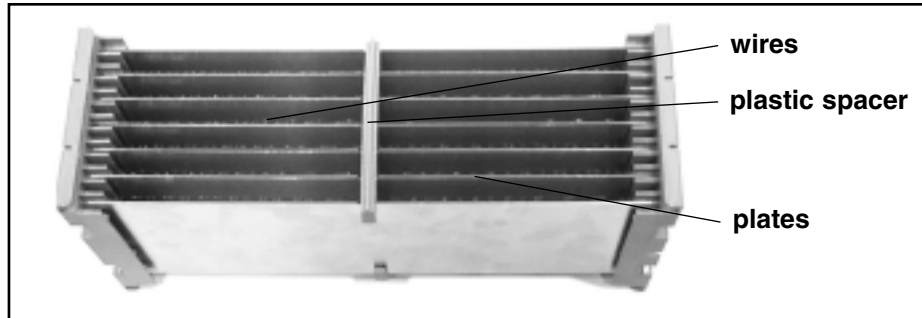

5. Thoroughly Clean pre-filter with warm soapy water.
6. Clean negative ion generator tip with a alcohol and a cotton swab.
7. Clean the dirt and grime from the motor shaft using a soft cloth.
8. Squirt a few drops of machine oil ("3 in 1" type oil, not WD-40 type oil) in the slot on the shaft to lubricate the bearing.
9. Check to ensure blower wheel rotates freely.
10. Check to ensure rubber grommet on motor shaft is not worn or loose. Replace if necessary.
11. Check the bearing in the bearing wall (opposite end of motor) on other end of blower wheel for excessive wear or damage. Replace if necessary.
12. Re-install collecting cell and pre-filter.
13. Install New Post Filter (Activated Charcoal Filter).

# Troubleshooting Guide

**Warning:** The troubleshooting portion of this manual requires that the unit power be “ON” for much of the servicing portion of troubleshooting. When working on the unit under power, use all of the standard precautions in working with any electro-mechanical device that contains line voltage, high voltage, and rotating elements. Failure to follow standard safety procedures can cause electrical shock, personal injury or property damage.

## Initially:

1. Plug the unit into a proper outlet.
2. Check the unit on all speeds to see if the blower and motor are operating properly. The power supply light should not operate on the “fan” selection mode.

## Problem Being Checked:

### 1. If the motor and blower do not operate:

- a. Check the top for proper positioning. The top must fit tightly on the unit.

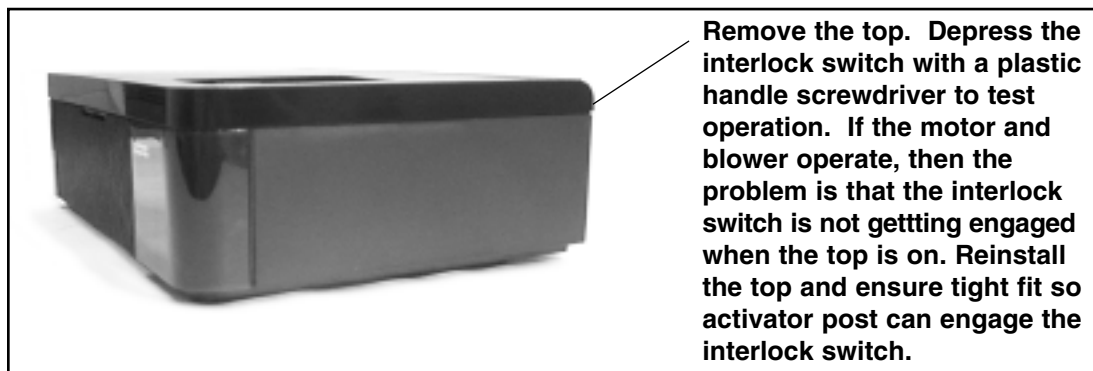

- b. With the top removed, depress the interlock switch with a plastic handle screwdriver to test operation.
- c. If the motor and blower operate, then the problem is that the interlock switch is not engaged when the top is on.
- d. Check the top to see if there is a broken activator post.
- e. Check the top to determine if it is warped. If the top appears to be warped, try a new top.

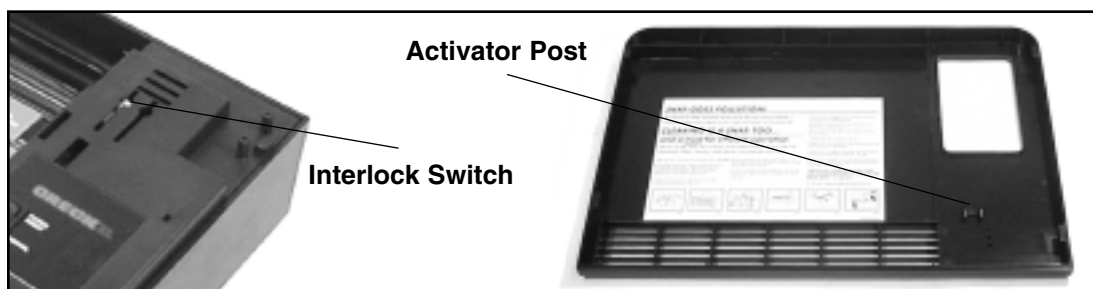

Turn the top over and examine it for a broken activator post. Lay the top on a smooth surface. Check it for warpage that could keep the interlock switch from being engaged.

- f. Check the interlock switch (item 3 of the parts diagram).

# Troubleshooting Guide

## *How to Remove the Power Supply Cover*

1. Insert flathead screwdriver into slot on the interior edge of the power supply cover, and push plastic clip away from contact wall so that the cover can be lifted up.



2. The switch wires will limit the movement of the power supply cover.
3. Is the switch actuator broken?

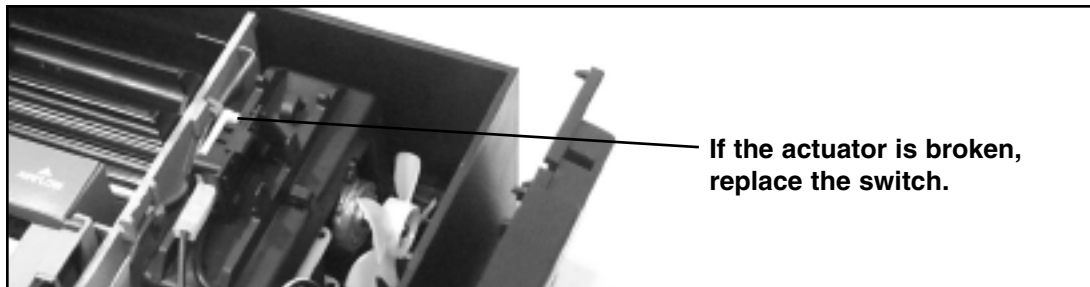

4. Is the switch properly seated in the bracket, or is the bracket broken or distorted? The switch is held in position by a bracket that allows the switch to be snapped between two locator ribs on the bracket.

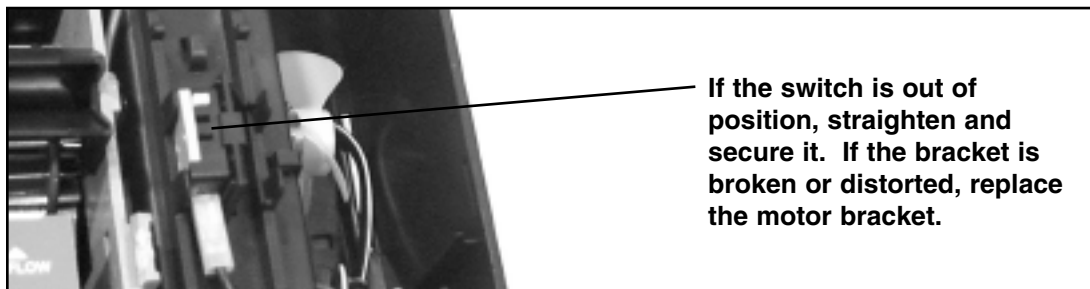

5. Are the wires connected to the switch?

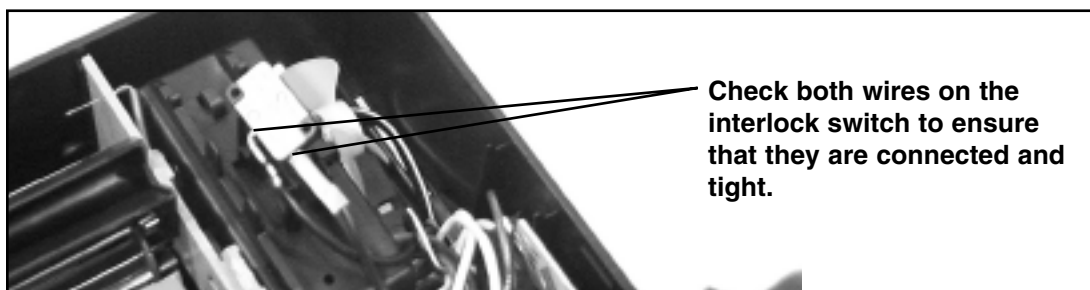

# Troubleshooting Guide

6. Check the voltage to and from the switch when activated. You should be able to measure line voltage entering and leaving the switch when activated.

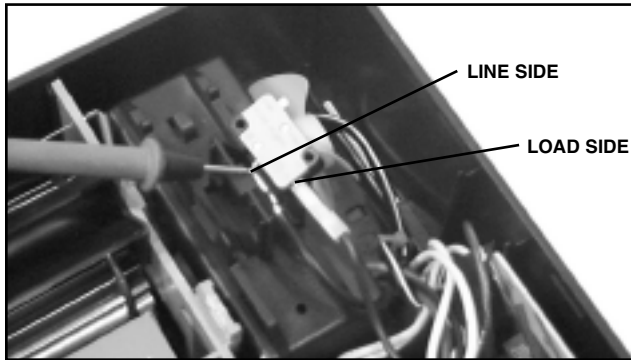

**TO SWITCH**, If voltage is present on line side of the switch but not present on load side, the switch is bad. **FROM SWITCH**, If there is no voltage on line side of the switch, check the wall outlet. If there is voltage at the outlet, then the line cord is bad.

7. Check the switch plate cover. The plate must sit squarely on the bearing wall and the cabinet base.



If the switch plate cover is not secure, it will prevent the top from engaging the interlock switch. Insure that the cover is in position.

## **2. If the motor operates but the green “cleaning air” light does not operate:**

- a. Remove the cell and check to see if the “cleaning air” light comes on.



- b. If the light operates with the cell removed, check the cell for broken wires that could cause a dead short. Check to see if the cell plates are bent or touching. Check to see if there is a foreign object in the cell. Check for carbon paths or tracks on the cell ends.

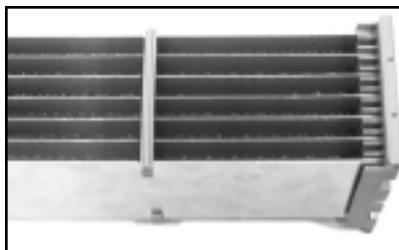

If the cell has loose or broken wires or bent plates, replace the cell. If there are no loose or broken wires present, hold the cell up to the light and look for metal shavings or anything that may be causing a short. If nothing is apparent, clear and retest the cell. If the problem persists, replace the cell. If carbon tracking is present on cell ends, replace the cell.

# Troubleshooting Guide

- c. If the light does not operate with the cell removed, check the wires to the light and confirm that they are properly connected. Check the voltage from the light terminals on the power supply board. Set meter to appropriate scale. You should have about 16 volts DC.

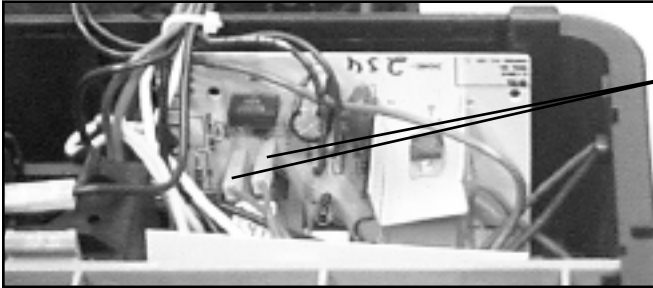

If the wire has voltage, the light is bad and needs to be replaced. If the wire does not have voltage, go to next step.

- d. **Option 1:** Check the output of the power supply by using the recommended H.V. probe and a multimeter. The unit must be "ON" with the operating switch in the "Max Clean" position and the interlock switch must be depressed. The voltage should measure from -5.5 KVDC to -7.0 KVDC. An alternate method to check voltage is by using a plastic handled screwdriver to short the high voltage contacts and observe a spark.

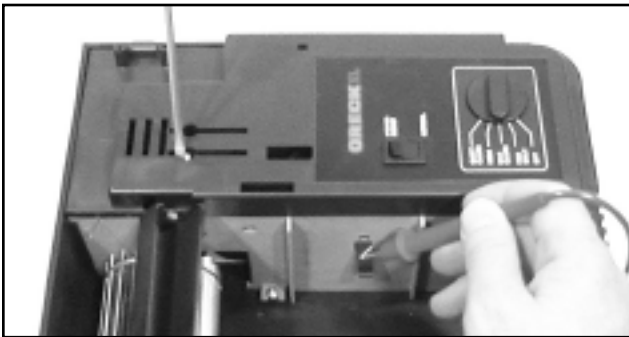

If the voltage is not present, check the transformer output. If the voltage is present and not within range, replace the power supply board and check the transformer output. If the voltage is present and within range, the power supply is operating properly.

**Option 2:** Using a plastic handle screwdriver, short the high voltage contacts and observe a spark.



Short the HV contacts to observe a spark.



# Troubleshooting Guide

- e. Check the input voltage to the transformer using a standard lead and a multimeter. Check the voltage from the black lead on the terminal L speed control switch and white lead on power supply board labeled line neutral. Activate the interlock switch. The meter should indicate line voltage. Check the voltage on the two yellow wires on the power supply board from the transformer. The interlock switch must be activated. The meter must indicate 24 vac.

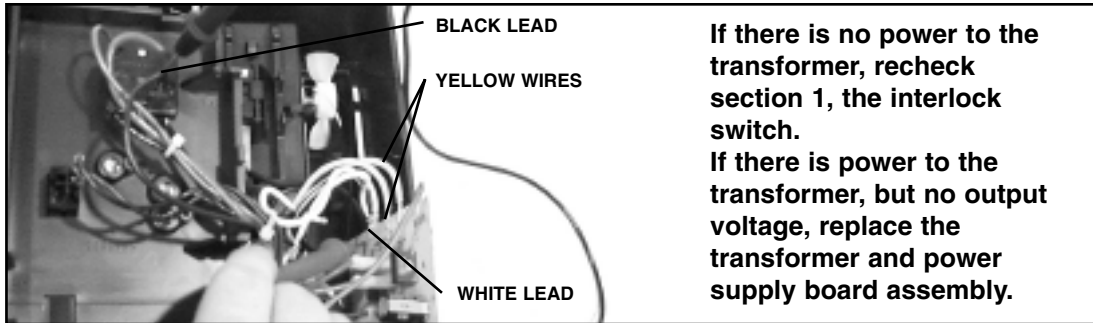

### 3. If the green "cleaning air" light operates and the blower wheel does not turn.

- a. Remove the top and check to see if the stripper is in place.

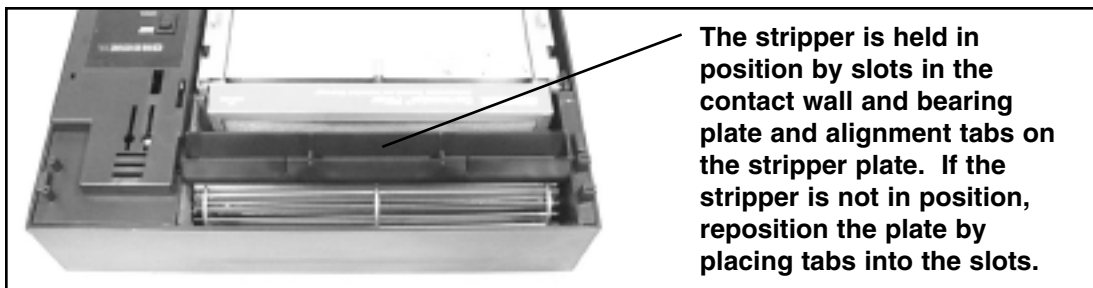

- b. Use your hand to try to spin the blower wheel.



- c. Turn the unit over and check for signs of distortion in the cabinet bottom beneath the motor that might prevent the blower from spinning.

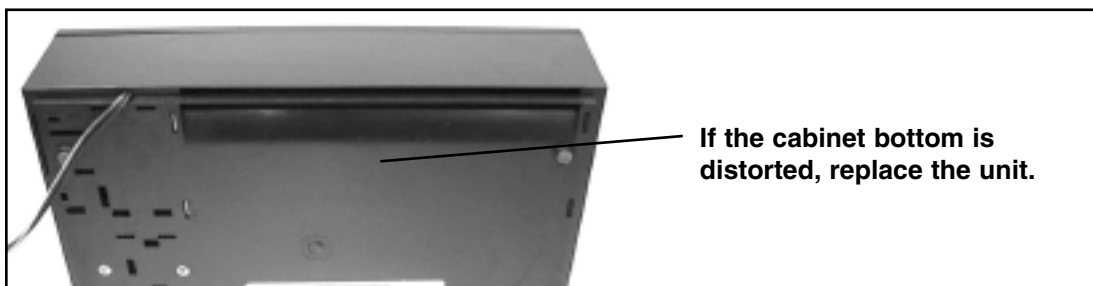

# Troubleshooting Guide

- d. If there are no signs of distortion, remove the blower wheel (see: **Blower Wheel Removal**) and activate the unit. Notice if the motor shaft rotates without the blower wheel. If the motor shaft operates, the problem is related to the blower wheel.

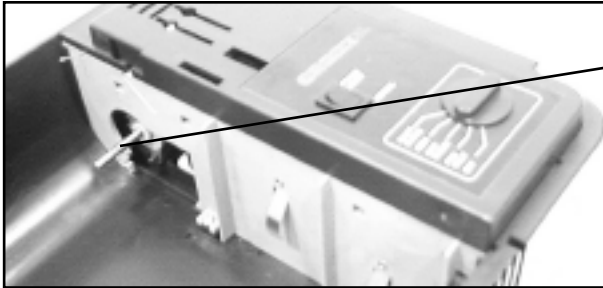

If the motor shaft rotates then replace the blower wheel drive grommet and bearing wall. If the motor shaft does not rotate, replace the motor.

4. **If the motor shaft does not turn on all speeds, or seems sluggish, it may be due to a build-up of dirt and grime on the motor shaft. To remedy this.**

- a. Clean the dirt and grime from the motor shaft using a soft cloth.

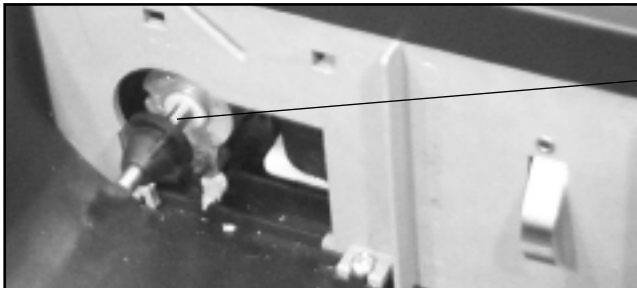

Motor Shaft

- b. Squirt a few drops of lubricating oil (“3 in 1” type oil, not WD-40 type oil) in the slot on the shaft to lubricate the bearing.

5. **If the blower wheel vibrates:**

- a. Check for bent or warped blades.

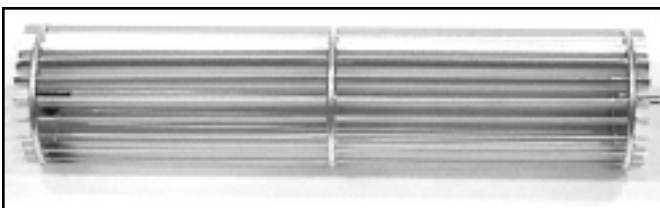

Replace the blower wheel if blades appear warped or bent.

- b. Check for loose or worn drive grommet.

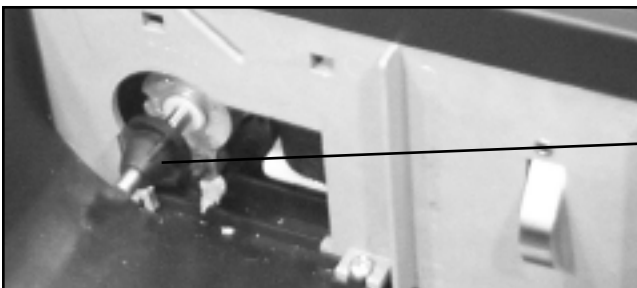

Replace the drive grommet.

# Troubleshooting Guide

- c. Check to see if the blower wheel is adequately supported by the outside bearing plate assembly.

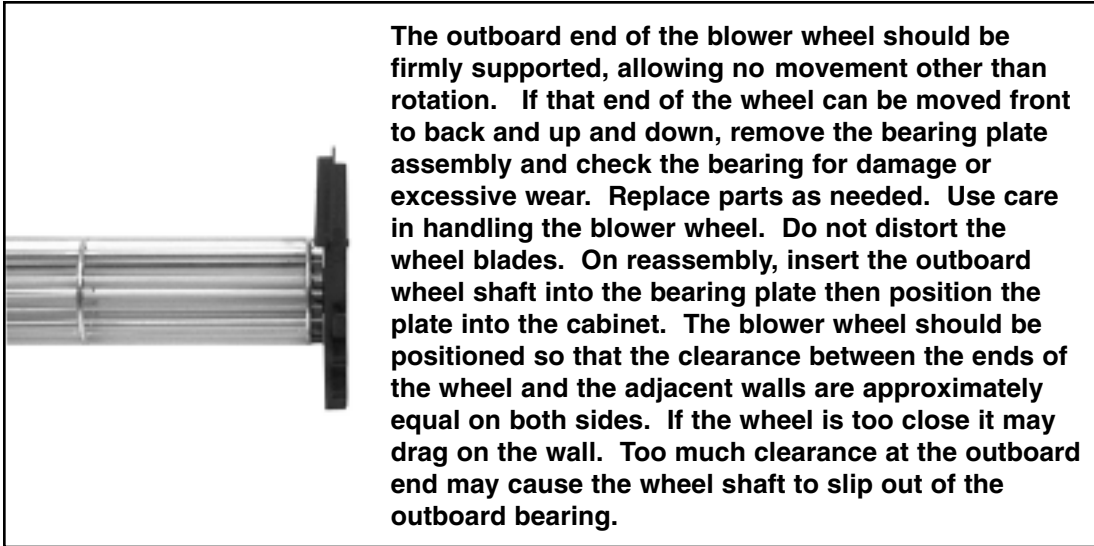

- d. Check to see if the motor mounting bracket snap tabs are in place or are loose. Look into the four base slots to see the tabs.

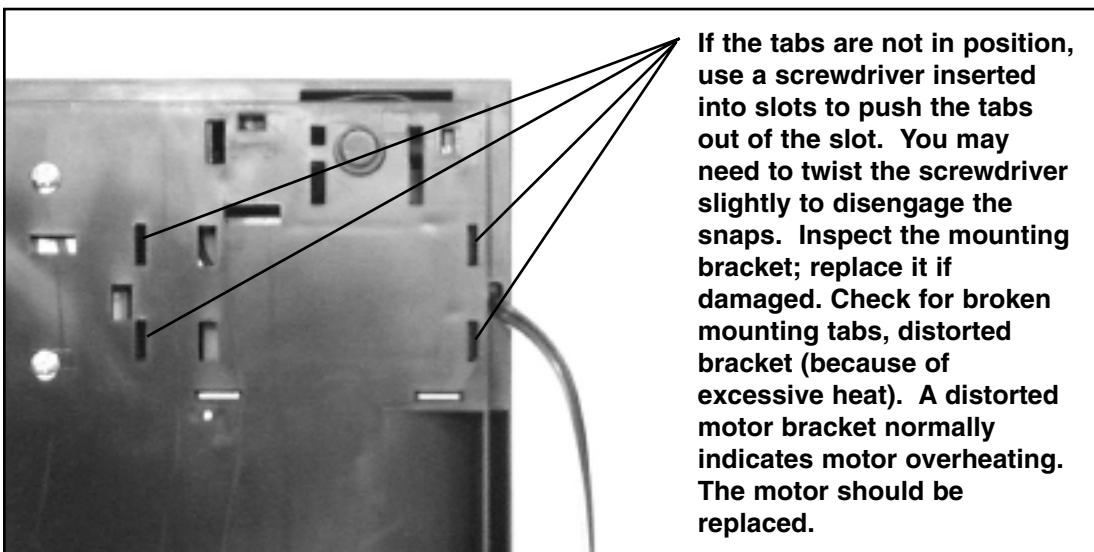

- e. Check to see if the motor is loose in the support bracket by holding the bracket and trying to move the motor. If the motor moves, remove the mounting bracket to check the isolator pads

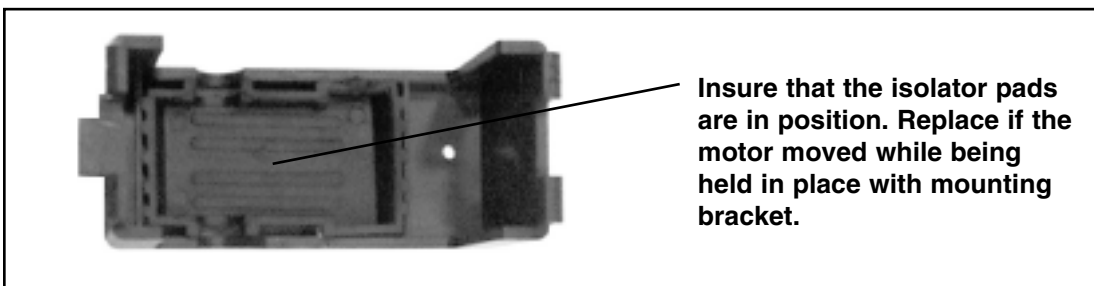

# Troubleshooting Guide

## 6 If the cell is arcing, check the following:

- a. If there are loose or broken ionizer wires.



- b. If the cell is dirty. Remove the cell and wash with warm soapy water. Dry completely before re-installing.

- c. If there are bent cell plates.



- d. If the cell is improperly installed in the unit.

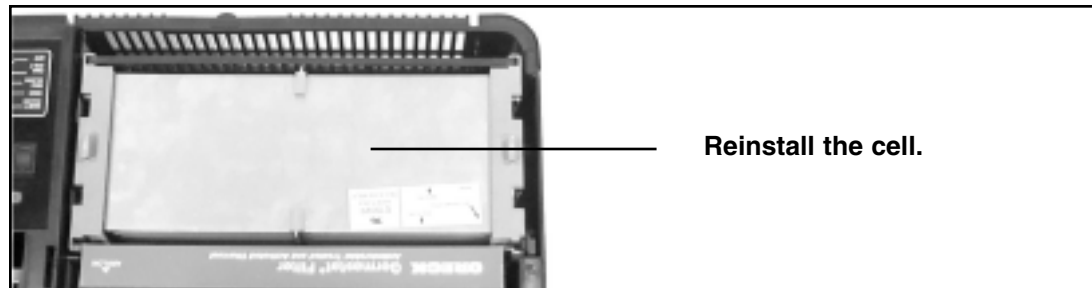

- e. If the cell contacts are broken or loose.

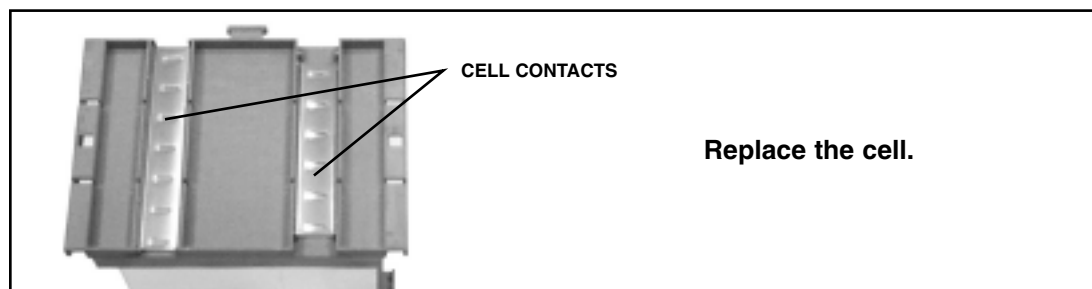

# Troubleshooting Guide

- f. If the H.V. contacts are not properly aligned or the contact wall is not properly aligned.

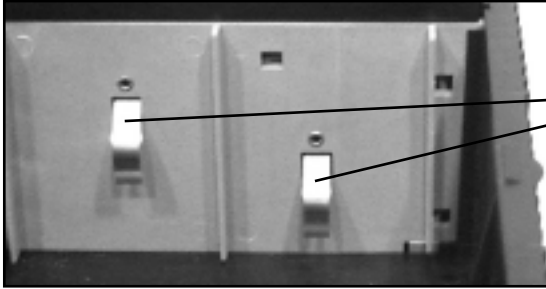

The H.V. contacts must make good contact. Replace the contact wall or straighten the contacts, if possible.

## 7. Checking for ionizing needle operation. Using HV voltage probe check needle for high voltage -5.5 KVDC to -7.0 KVDC.

- a. If voltage is present, the ionizer is OK.

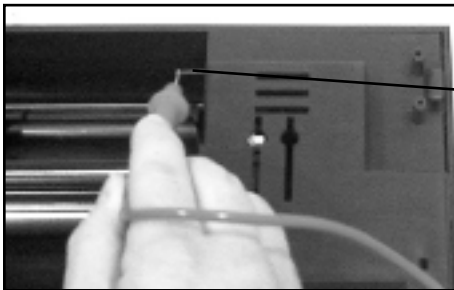

Clean needle with alcohol and a cotton swab.

- b. If voltage is not present, check HV power supply.

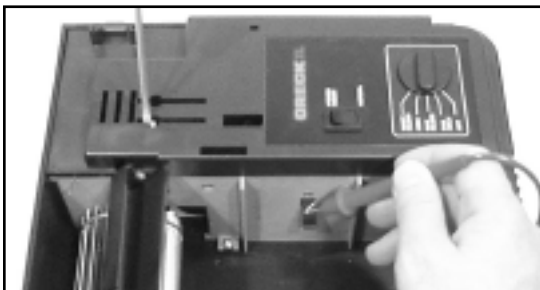

See above diagram.

- c. If voltage is present at HV power supply but not the needle.

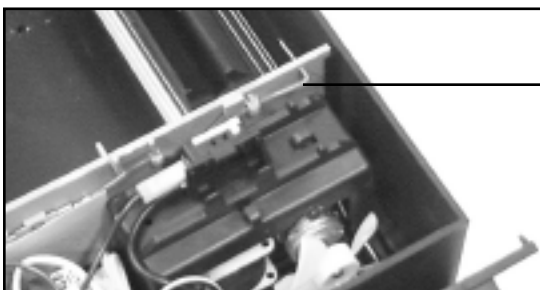

Replace the negative ionizer assembly including wire, with needle attached, and terminal.  
**IMPORTANT: Replace using wire routing on contact board.**





## **Super Air 5 Model 447628**

### ***Parts Removal and Replacement***

#### **General Parts Replacement**

---

<b><i>Motor Removal and Replacement</i></b>	<b><i>page 16</i></b>
<b><i>Power Supply Removal and Replacement</i></b>	<b><i>page 19</i></b>
<b><i>Transformer Removal and Replacement</i></b>	<b><i>page 21</i></b>
<b><i>Bearing Wall Assembly and Blower Wheel Removal and Replacement</i></b>	<b><i>page 22</i></b>
<b><i>Led Assembly Removal and Replacement</i></b>	<b><i>page 23</i></b>
<b><i>Cell Assembly Removal and Replacement</i></b>	<b><i>page 23</i></b>
<b><i>Ionizer Needle Removal and Replacement</i></b>	<b><i>page 23</i></b>
<b><i>Fan Blade Removal and Replacement</i></b>	<b><i>page 24</i></b>



**Warning** - All parts removal and replacement should be performed with power disconnected from the unit.

# General Parts Replacement

## ***Motor Removal and Replacement***

1. Remove the cabinet top by pressing down the thumb latch and sliding the top forward.
2. Remove the cell assembly (see inside of top for instructions).
3. Remove the stripper by pulling it to the right and applying pressure to the bearing wall. Lift the left hand side of the stripper out of the bearing wall locator seat and then remove the stripper.
4. Flip the unit onto its side with the bearing wall up and release the two locking tabs for the bearing wall assembly by using a regular screwdriver from the bottom. Place screwdriver blade into the slot on top of the snap finger locking tab and twist the blade slightly while pulling on the bearing plate. Repeat for the second tab. The bearing wall may now be removed by moving the blower wheel and bearing wall away from the cabinet and lifting the bearing wall off of the blower wheel.

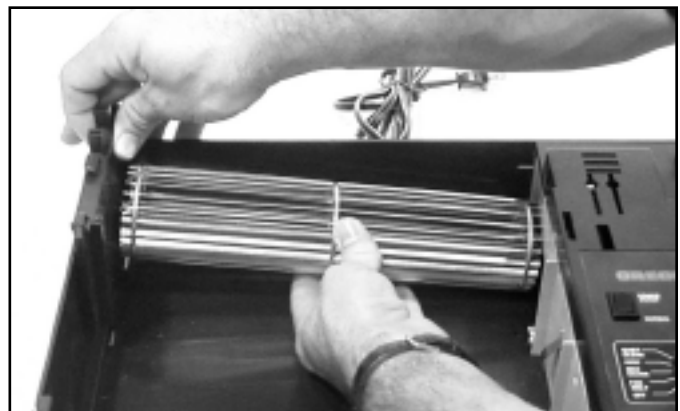
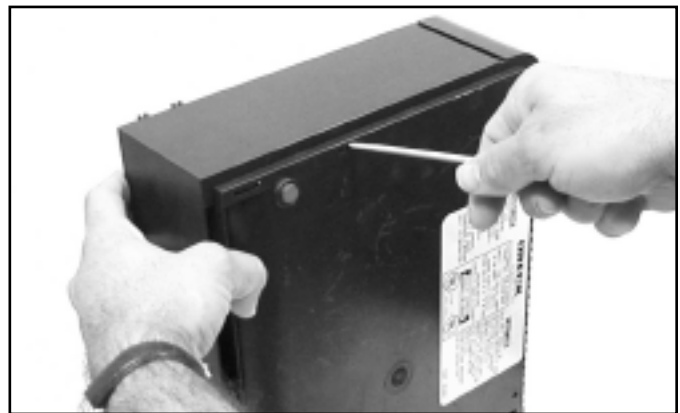
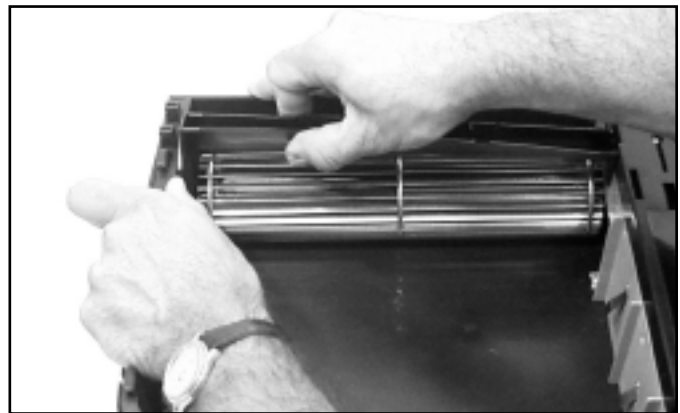
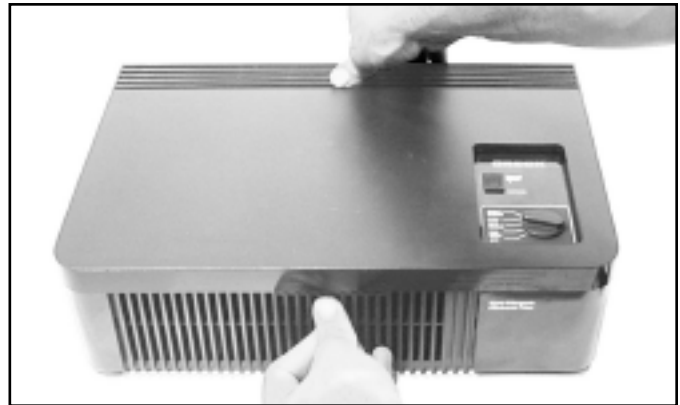



# General Parts Replacement



**ROTATING ELEMENT WARNING** - Unit has a rotating blower wheel and cooling fan to circulate air and keep the unit cool. When servicing the unit and repairing the unit always insure that you keep objects and internal electrical wiring away from the rotating elements. Failure to allow for proper clearance for rotating members can cause electric shock, personal injury or property damage.

5. Remove the blower wheel by gently grasping the outside of the wheel at the center support rib and the rib closest to the motor. Tilt the wheel up and pull it away from the motor shaft. The blower wheel rubber grommet is glued to the shaft of the motor and will remain attached to the motor.

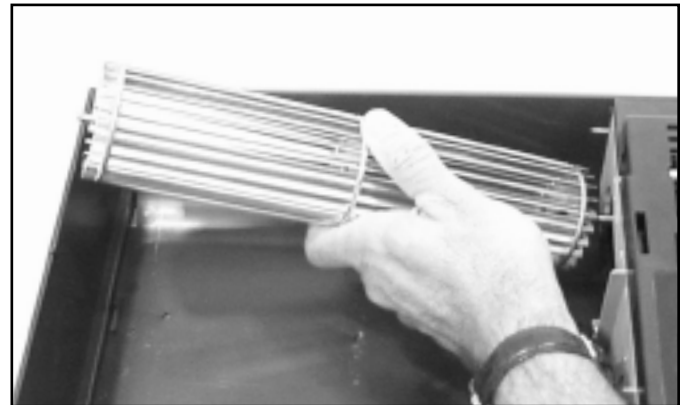

6. Remove the power supply cover by placing a screwdriver blade in the cover slot with the blade inserted on the blower wheel side of the slot. Catch the tan snap tab and twist the screwdriver slightly while lifting up on the cover and remove the power supply cover assembly. Lay the assembly aside out of the way.



7. Remove the interlock switch from the mounting bracket by releasing the snap lever and lifting the switch out of the bracket. It is not necessary to disconnect the switch wires.

8. Turn the unit over. Use a screwdriver to release the motor mounting bracket locking tabs by inserting the screwdriver blade between the snap tab and the housing. Twist the snap tab toward the center of the four motor mounting slots. You will need to pull the mounting bracket away from the cabinet while releasing the tabs. After releasing all four tabs, remove the bracket.

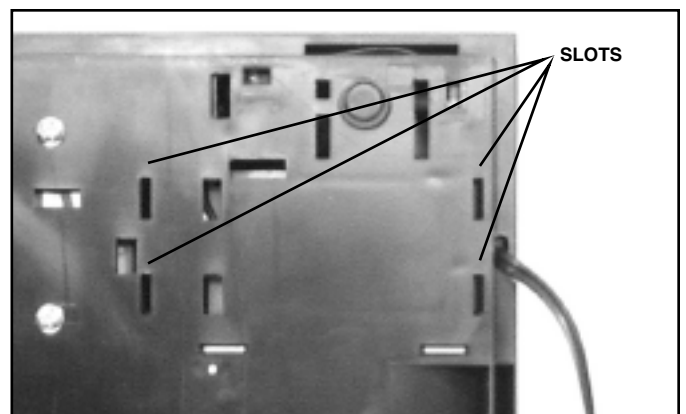

# General Parts Replacement



**HIGH VOLTAGE WARNING** - This equipment is supplied with line voltage from a standard wall socket. Use standard precautions in working on it with line voltage applied. Failure to practice normal electrical safety precautions can cause electrical shock, personal injury or property damage.

9. Unplug the red terminal (3), brown terminal (2) and black terminal (1) wires from the selector switch by pushing a paper clip (straightened) under the wire into the switch while pulling on the wire lightly.
10. Remove the white motor wire from the power supply board line neutral connection.
11. Remove the motor and replace it with the new motor.
12. Reverse the above steps to replace the motor.
13. It is important that the motor isolators are installed correctly and are seated as designed. Contacts on side of insulator should fit over motor bearing bracket. Motor and isolators must fit securely.

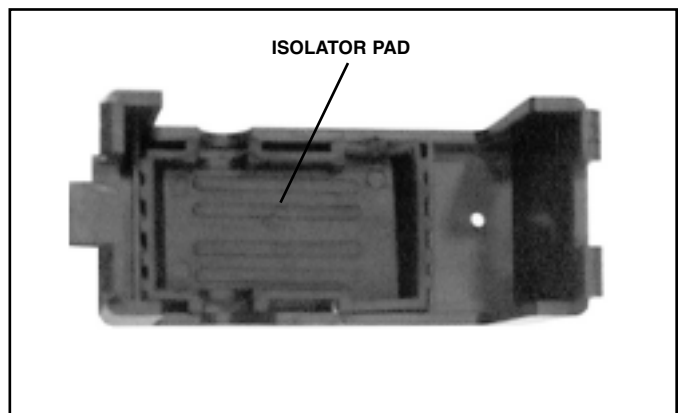
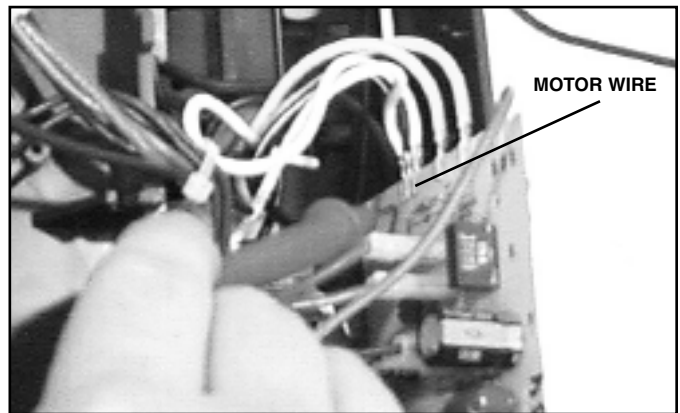
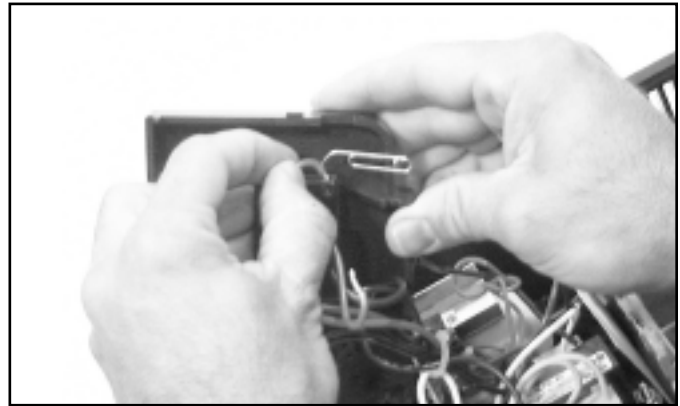

# General Parts Replacement

## ***Power Supply Removal and Replacement***

1. Follow steps 1, 3, and 6 of ***Motor Removal and Replacement***.



**EXTREME HIGH VOLTAGE WARNING** - This equipment is supplied with line voltage from a standard electrical wall socket. That voltage is transformed to a 24V signal that is then amplified to over 6000VDC. In working with the equipment you must always know the voltage level for the equipment and wiring. Attempting to measure or work with the 6000 VDC power without using the proper high voltage probe can cause electrical shock, personal injury or property damage. Probing a high voltage without the proper meter will potentially damage the volt meter.



**EXTREME HIGH VOLTAGE WIRING WARNING** - The unit has been designed such that extremely high cell collector voltage wiring is isolated from all other wiring. Special wiring routing holders have been designed into the unit. This extremely high voltage wiring must be routed correctly. Failure to route and isolate the wire can create a fire hazard, personal injury or property damage.



**INSULATOR BOARD WARNING** - The unit has been designed with special insulator and isolator spacer boards that must be in position. These boards are made of a special insulator material and must be in position to properly isolate wiring and connectors from uninsulated parts. Failure to place the boards in the proper location can create a fire hazard, cause personal injury, or property damage.

2. Before removing the HV power supply board make note of the position of all the wiring. You will note that all wiring is bound and well away from the motor fan. The HV power single red line coming from the left hand side of the board is routed in special built-in plastic routing holders and isolated from all other wires. Note that the routing and isolation is critical and must not be altered. In addition, the two insulator sheets are preset and must be in position. After carefully noting the above, remove the HV power supply board by first removing the HV red lead from the bottom holder. You can now lift the board up and rotate it into a position to allow the connectors to be removed. Reconnect the replacement board by carefully removing one wire at a time from the connected board and placing it on the same location on the replacement board.

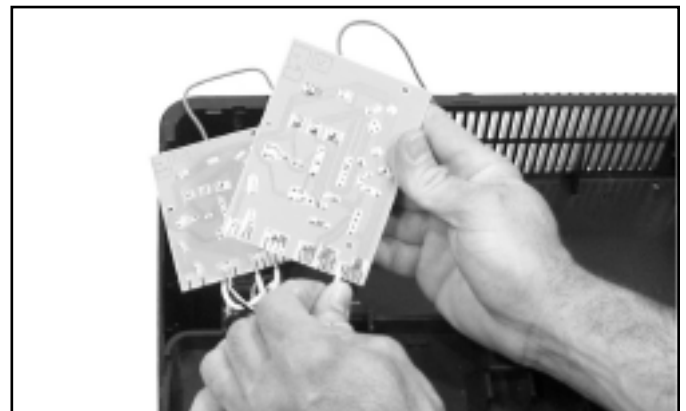
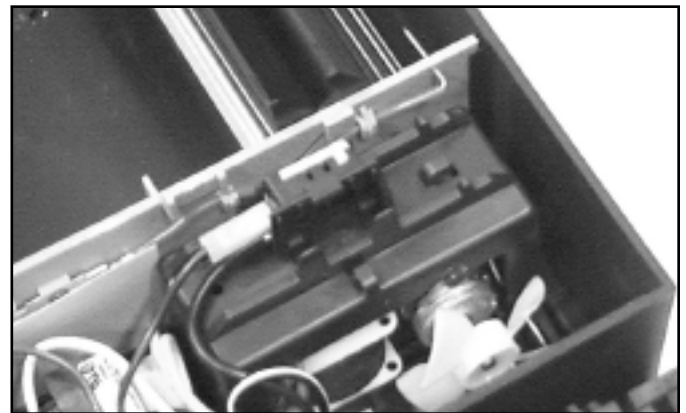

# General Parts Replacement

All leads must be connected to the new board properly. The HV power line must be isolated and properly routed. Two insulator sheets must be in position and all wiring must be captured to prevent contact with rotating elements. A wiring diagram is included in the service manual for your use.

3. The new board may now be reinstalled in the housing by sliding it back into position. The housing has two board reference ribs molded in the bottom that hold the board in position. Position the board between the side wall and the reference ribs. You may need to hold the board in place before and during installation of the power supply cover.

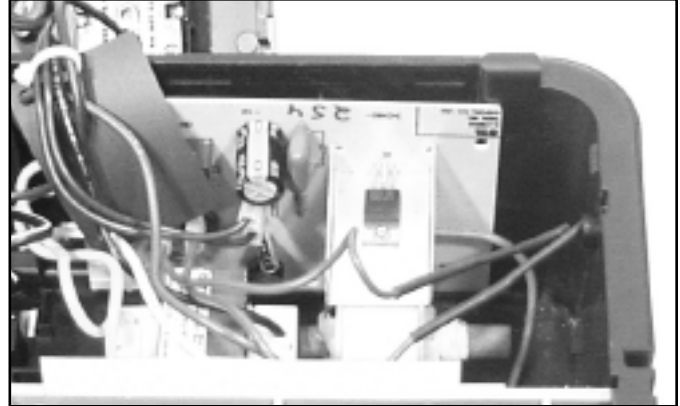

**ROTATING ELEMENT WARNING** - Unit has a rotating blower wheel and cooling fan to circulate air and keep the unit cool. When servicing the unit and repairing the unit always insure that you keep objects and internal electrical wiring away from the rotating elements. Failure to allow for proper clearance for rotating members can cause electric shock, personal injury or property damage.

4. The power supply cover may now be reinstalled. Check wiring to insure it is routed properly and cannot contact motor fan and is properly isolated. Install the power supply cover by placing the cover locator tabs into the cabinet at an angle while rotating it into place. The locking snap should engage when in the final position.



**EXTREME HIGH VOLTAGE WARNING** - This equipment is supplied with high voltage from a standard electrical wall socket. That voltage is transformed to a 24V signal that is then amplified to over 6000 VDC. In working with the equipment you must always know the voltage level for the equipment and wiring. Attempting to measure or work with the 6000 VDC power without using the proper high voltage probe can cause electrical shock, personal injury or property damage. Measuring high voltage without the proper meter and probe will potentially damage the volt meter.

# General Parts Replacement

5. To test the power supply, touch the metal shaft of a screwdriver, with an insulated or plastic handle, to one of the contacts while keeping the screwdriver tip about 1/8" away from the other contact. You should see an arc and hear a snapping sound.
6. Reverse step 1.



## **Transformer Removal and Replacement**

1. Follow steps 1, 2, 3, and 6 of **Motor Removal and Replacement**. Remove two #6 screws and nuts that secure the transformer to the cabinet bottom. Save for installment of the new transformer.

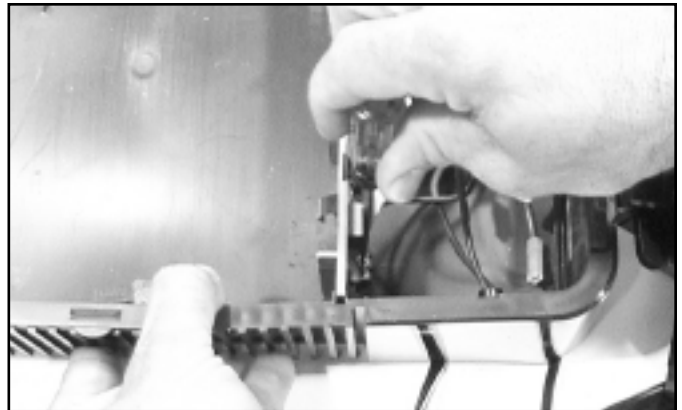

**HIGH VOLTAGE WARNING** - This equipment is supplied with line voltage from a standard wall socket. Use standard precautions in working on it with line voltage applied. Failure to practice normal electrical safety precautions can cause electrical shock, personal injury or property damage.



**ROTATING ELEMENT WARNING** - Unit has a rotating blower wheel and cooling fan to circulate air and keep the unit cool. When servicing the unit and repairing the unit always insure that you keep objects and internal electrical wiring away from the rotating elements. Failure to allow for proper clearance for rotating members can cause electric shock, personal injury or property damage.

2. Remove the power supply and disconnect the yellow low voltage leads and white line voltage lead. Remove the black input line to selector switch position 4 using a straightened paper clip inserted into the selector switch connection.

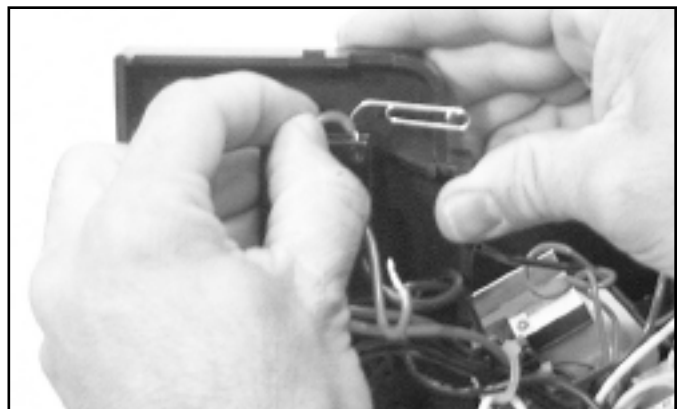

# General Parts Replacement

3. Remove the two #8/32 lockwasher nuts and remove the transformer and replace it with the new unit.
4. Reverse the above steps 1,2, and 3 to replace the transformer.



## ***Bearing Wall Assembly and Blower Wheel Removal and Replacement***

1. Follow steps 1, 2, 3, 4 and 5 of ***Motor Removal and Replacement***.
2. The rubber grommet will need to be removed from the motor shaft. This can be done by cutting it off using a sharp razor knife and slitting the grommet along the motor shaft axis. You can then peel the grommet off of the shaft. The motor shaft must be clean before installing the new blower wheel and grommet. Using a razor knife, carefully remove any sealant on the shaft and wipe it with a clean cloth.

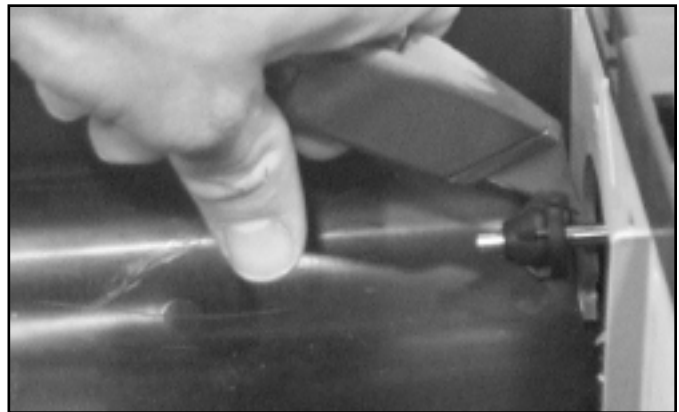

3. You are now ready to reinstall the new lower wheel and grommet assembly. Place one drop of adhesive (loctite 401 or equivalent "super glue" type adhesive) on the motor shaft in the small groove about 1/2" from the blower wheel attachment end. Place the new bearing wall assembly on the blower wheel shaft. Slide the grommet on to the motor shaft and rotate the bearing wall and blower into position. Snap the wall into the cabinet. Move the blower wheel so that the tips of the blades are about 1/4" from the bearing wall.



4. Reverse the above steps 1, 2 and 3 and to replace the bearing wall and blower wheel.

# General Parts Replacement

## ***Led Assembly Removal and Replacement***

1. Follow steps 1, 2, and 6 of ***Motor Removal and Replacement***.
2. Disconnect the two red led leads from the power supply board and remove the led assembly by removing the led retaining ring from the back of the front panel and removing the led and the leads.
3. Replace with a new led assembly.
4. Reverse the above steps 1 and 2 to replace the led assembly.

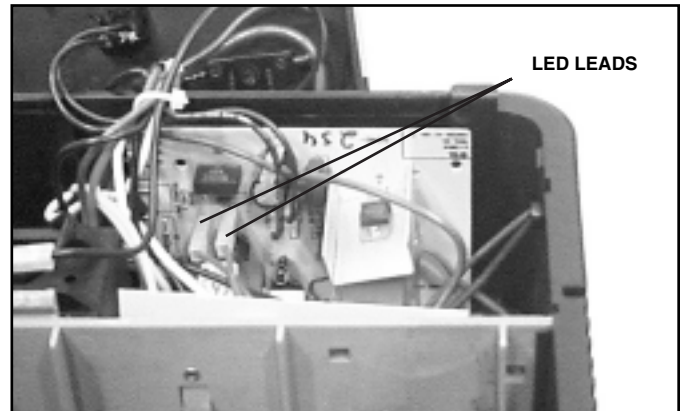

## ***Cell Assembly Removal and Replacement***

1. Follow steps 1 and 2 of ***Motor Removal and Replacement***.
2. Replace with a new cell.
3. Reverse the above step 1 to replace the cell.

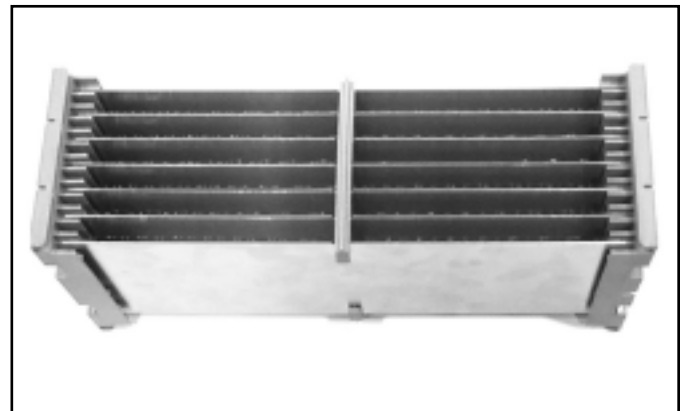

## ***Ionizer Needle Removal and Replacement***

1. Follow steps 1, 3, and 6 of ***Motor Removal and Replacement***.



**EXTREME HIGH VOLTAGE WARNING** - This equipment is supplied with line voltage from a standard electrical wall socket. That voltage is transformed to a 24V signal that is then amplified to over 6000 VDC. In working with the equipment you must always know the voltage level for the equipment and wiring. Attempting to measure or work with the 6000 VDC power without using the proper high voltage probe can cause electrical shock, personal injury or property damage. Probing a high voltage without the proper meter will potentially damage the volt meter.

# General Parts Replacement



**EXTREME HIGH VOLTAGE WIRING WARNING** - The unit has been designed such that extremely high cell collector voltage wiring is isolated from all other wiring. Special wiring routing holders have been designed into the unit. This extremely high voltage wiring must be routed correctly. Failure to route and isolate the wire can create a fire hazard, personal injury or property damage.

2. Carefully remove the ionizer needle assembly that is the piece of red insulated wire with fast on connection on one end and the needle on the other end. Replace with new needle assembly.
3. Reverse step 1 above to replace assembly.

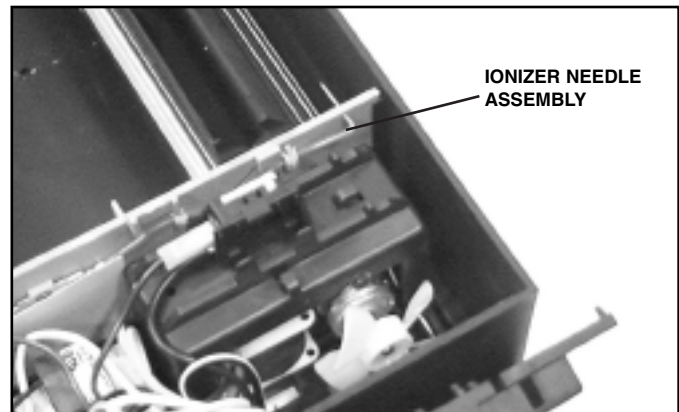

## ***Fan Blade Removal and Replacement***

1. Follow steps 1, 2, 3, and 6 of ***Motor Removal and Replacement***.



**ROTATING ELEMENT WARNING** - Unit has a rotating blower wheel and cooling fan to circulate air and keep the unit cool. When servicing the unit and repairing the unit always insure that you keep objects and internal electrical wiring away from the rotating elements. Failure to allow for proper clearance for rotating members can cause electric shock, personal injury or property damage.

2. Remove fan with flathead screwdriver by lightly prying the fan off of the motor shaft.
3. Replace the fan with the new fan and insure that the new fan is installed on the motor shaft with the metal locking collar closest to the motor body. Press the fan onto the shaft and allow about 1/4" distance between the motor end bracket and the fan hub. Spin the fan to ensure it is clear of all objects.
4. Reverse above step 1 above to replace the fan.





# Parts List

QTY	ITEM #	PART NO.	DESCRIPTION
1	1	242235-001	SWITCH KNOB, BLACK
1	2	242331-007	TRANSFORMER
1	3	242404-001	INTERLOCK SWITCH
1	4	247135-001	FAN BLADE
2	5	AT2PK	CHARCOAL COMBINATION FILTER
1	6	247667-001	CONTROL LABEL
1	7	342472-002	CONTACT WALL ASSEMBLY
1	8	342480-003	PLASTIC MESH PREFILTER
1	9	254682-001	BLOWER WHEEL KIT
1	10	254681-001	MOTOR KIT ( <b>BALL BEARING MOTOR DOES NOT REQUIRE COOLING FAN</b> )
1	11	451686-003	CABINET TOP, GRAY
1	12	442415-101	COLLECTOR CELL
1	13	142475-001	ION NEEDLE ASSEMBLY
1	14	342228-001	STRIPPER
1	15	342227-001	MOTOR MOUNTING BRACKET
1	16	136483-001	DRIVE GROMMET
1	17	342402-251	HV POWER SUPPLY BOARD
1		342402-254	HV POWER SUPPLY BOARD "HUMP BACK"
1	18	442223-201	CABINET BOTTOM
2	19	242253-001	MOTOR ISOLATOR PAD
1	20	142581-001	SWITCH ASSEMBLY
1	21	145820-002	SWITCH ROCKER
1		40184-01	CARTON
1		442414-001	CARTON INSERT
2	<b>NLA</b>	20CFT	CHARCOAL FILTERS ( <b>NO LONGER AVAILABLE</b> )
3		30CFT	CHARCOAL FILTERS
1		33358	CELL CLEANER
1		242809-015	OWNER'S MANUAL

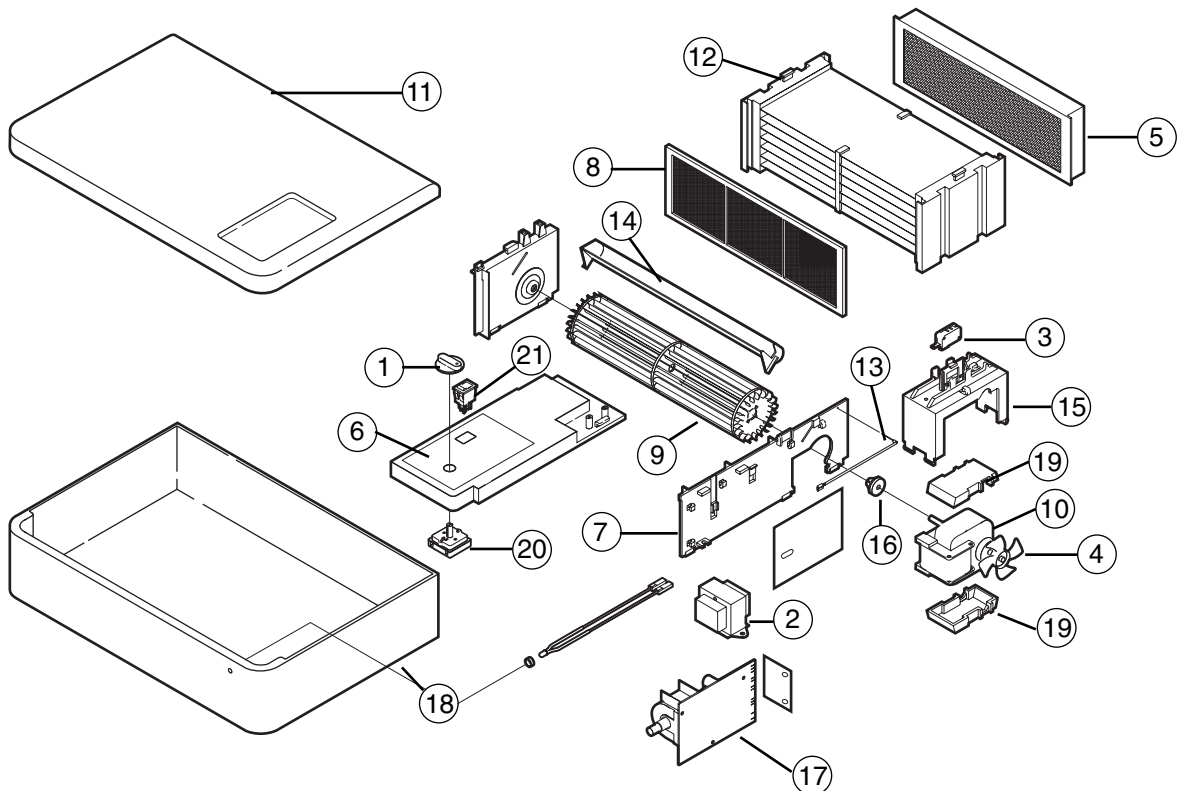

# Wiring Diagram

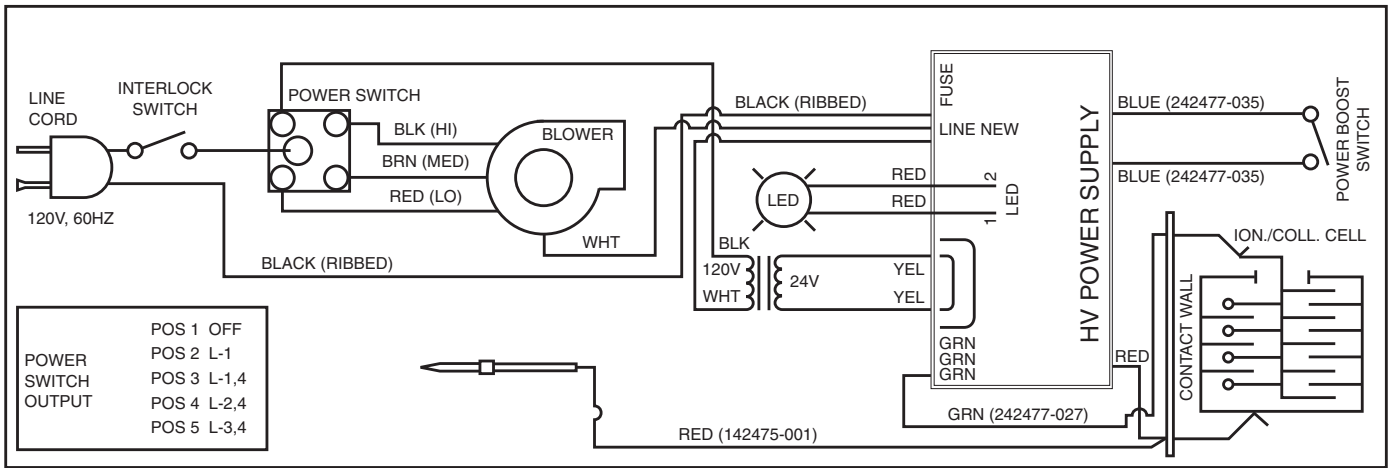





## Free Manuals Download Website

<http://myh66.com>

<http://usermanuals.us>

<http://www.somanuals.com>

<http://www.4manuals.cc>

<http://www.manual-lib.com>

<http://www.404manual.com>

<http://www.luxmanual.com>

<http://aubethermostatmanual.com>

Golf course search by state

<http://golfingnear.com>

Email search by domain

<http://emailbydomain.com>

Auto manuals search

<http://auto.somanuals.com>

TV manuals search

<http://tv.somanuals.com>