



User Guide S209

1.8GHz DECT Dual line expandable cordless phone system

Retain this user guide for future reference

Table of Contents

1	Environment and Safety	1
2	What's in the Box?	2
3	Welcome	3
	How to use this user guide?	3
	Need more help?	3
4	About your Oricom S209 cordless handset	4
	The Handset	4
	The Base	5
	Handset icons	5
	The menus	5
5	Getting Started	7
	Connecting your phone	7
	Connecting your charger	7
	Charging your handset	7
	Checking the battery level	8
	Wall mounting the base	8
	Greeting you with "HELLO"	9
	What is standby mode?	9
	Registering your handset	9
	Checking the signal strength	9
	Switching your handset on/off	10
	Setting the clock	10
6	Call	11
	Making a call	11
	Ending a call	13
	Answering a call	13
	During a call	14
	Dual line calls	15
7	Intercom and Conference Calls	16
	Calling another handset	16
	Transferring a call	16
	Making a conference call	16
8	Text and Numbers	18
	Changing the letter case	18
	Entering text and numbers	18
	Erasing text and numbers	18
9	SMS Text Messaging (Australia only)	19
	Activating SMS	19
	Deactivating SMS	19
	Setting up SMS service centres	19
	About mailbox	20
	Organizing the public mailbox	20
	Organizing private mailbox	21
	Setting new message alert	22
	Reading and retrieving messages	23
	Returning a call to the sender	23
	Composing and sending messages	23
	Deleting a message	24
	Deleting all messages	25
	Checking the mailbox memory status	25
10	Voicemail Indication and Notifications	26
	Voicemail indication	26
	Notifications	26
11	Phonebook	27
	Viewing the phonebook	27
	Calling from the phonebook	27
	Adding a record	28
	Editing a record	29
	Deleting a record	29
	Deleting all records	29
	Using speed dial	29

Table of Contents

Checking the memory status	30
12 Call Log.....	31
Viewing the call records	31
Making a call	31
Saving a call record to your phonebook	32
Deleting a call record	32
Deleting all records	32
Call timeR	32
Log option	32
13 Services Directory.....	33
Viewing the directory	33
Calling from the directory	33
Adding a record	33
Editing a record.....	34
Deleting a record.....	34
Deleting all records	34
14 Custom Options.....	35
Personalizing your phone's display	35
Personalizing your phone's sounds.....	35
15 Your Digital Assistant	37
The alarm clock.....	37
The stopwatch.....	37
The countdown timer	38
16 Calling Features.....	39
Auto answer	39
Do not disturb.....	39
Recall selection	39
Pause Selection.....	39
Prefix insertion	40
PABX Prefix	40
Call barring	41
17 Extra Features.....	42
Direct paging.....	42
Call camping	42
Keypad lock	42
Missing handset(s).....	42
New message indication.....	43
18 The System	44
Reviewing/Selecting your country	44
Registering your handset(s) with additional base.....	44
Selecting a base unit.....	44
Deleting a handset	44
Defining line matrix.....	45
Changing the system PIN	46
Resetting to default settings.....	46
19 Appendix.....	47
Default Settings	47
Troubleshooting	48
Notes for Operation in New Zealand	48
Warranty	49
Customer Support.....	50

Environment and Safety

IMPORTANT

Please read the safety instructions before first use of this phone.

- Avoid exposure of this telephone to moisture or liquid.
- To prevent electric shock, do not open the handset or base cabinet.
- Avoid metallic contact (e.g. metal clips, keys) between the battery contacts and charging conductors.
- There is a slight chance that the telephone could be damaged by an electrical storm. It is recommended that users unplug the phone from the mains supply and telephone socket during a storm.
- Do not open the base unit or charger. This could expose you to high voltages.
- Do not use the handset in an explosive hazard area such as where there is gas leaking.
- There is a chance that the telephone could be damaged by an electrical storm. It is recommended that users unplug the phone from the mains supply and telephone socket during a storm.
- Do not use your telephone during an electrical storm thunderstorm as it is possible to get an electric shock. Refer to information contained in the White pages directory.
- Follow the local regulations regarding the disposal of your packing materials, exhausted batteries and used phone. Wherever possible, recycle those materials.
- We advise that this phone should not be used near intensive care medical equipment or by persons with pacemakers.
- Clean with a dry, soft, lint-free cloth. Never use cleaning agents, particularly aggressive solvents.
- Because the phone works by sending radio signals between base station and handset, wearers of hearing aids may experience interference in the form of a humming noise.
- Your phone may interfere with electrical equipment such as answering machines, televisions, clock radios and computers if placed too close. It is recommended that you position the base unit at least one metre from such appliances.
- This telephone complies with applicable safety requirements for exposure to radio waves (EMR). The mean power of this telephone does not exceed 20mW limit at which point testing is required.
- The earpiece of the handset may attract small metal objects such as staples and pins. Care should be taken when placing the handset near these items.
- This telephone is not designed for making emergency telephone calls when the mains power fails. Always have a corded phone available to be able to make and receive calls to emergency services if the mains power fails.



CAUTION: Use only the mains adaptors supplied with this equipment. Incorrect adapter polarity or voltage can seriously damage the unit.

Handset Charger Adapter
Input: 230VAC 50Hz
Output: 6VDC 400mA

Base Unit Adapter
Input: 230VAC 50Hz
Output: 9VDC 300mA

Battery requirements

Each handset requires two rechargeable Ni-MH batteries, size AAA 1.2V 750mAh (HR10/44).



WARNING: RISK OF EXPLOSION IF BATTERY IS REPLACED BY AN INCORRECT TYPE. Never use non-rechargeable batteries. Use recommended type supplied with this product. NiMH batteries must be disposed of in accordance with the applicable waste disposal regulations.

What's in the Box?

Make sure you have all these items in the box. For missing item(s), contact your dealer.

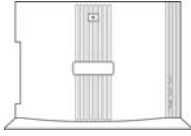

Base Unit



Handset x 2



Charger x 2



Base Power Adapter x 2



Charger Power Adapter x 2



Base Wall Mount Bracket



Rechargeable Ni-MH AAA Battery x 4



Handset Battery Cover x 2



Belt Clip x 2



Modular telephone Line Cord
x 2



This Owner's Manual

Modular (Australia only) adaptor plug
X 2

Welcome

This user guide provides you with information and instruction you need to get the most from your phone system.

HOW TO USE THIS USER GUIDE?

The following symbols are used to alert you on important information.



This symbol has two meanings:

- **Warning:** Critical information for preventing personal injury.
- **Caution:** Critical information for preventing damage on the product.



- **Tip:** Information for easier operation.



- **Note:** Explanatory or critical information for carrying out an operation correctly.

NEED MORE HELP?

- See the Troubleshooting section in this user guide on page 47.

About your Oricom S209 cordless handset

THE HANDSET

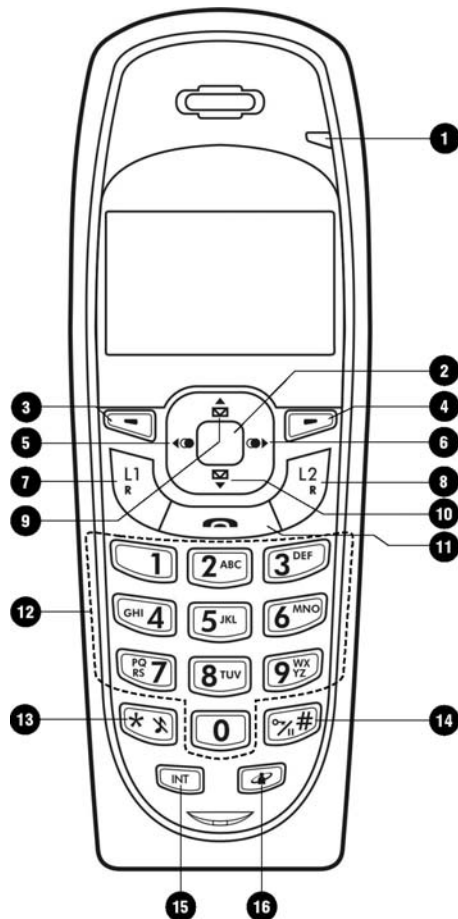

- 1 Handset Indicator**
Lit when call in progress.
Blink if there is unread SMS message(s) or missed call(s).
- 2 Direct Page key**
Use to make an instant call to another handset.
- 3 Soft Key 1 & 2**
& Use to perform function displayed above the key. It is displayed as text in a box (i.e **MENU**) in this guide.
- 4**
- 5 Left & Dialed List key**
Use to move the cursor.
Use to change selection.
Use to enter the dialed list.
- 6 Right & Dialed List key**
Use to move the cursor.
Use to change selection.
Use to enter the dialed list.
- 7 Line 1 & R key**
Use to make and receive calls.
Use to send flash signal.
- 8 Line 2 & R key**
Use to make and receive calls.
Use to send flash signal.
- 9 Up & Message key**
Use to scroll up menu items.
Use to increase the ringer and receiver volume.
Use to enter the Message menu.
- 10 Down & Message key**
Use to scroll down menu items.
Use to reduce the ringer and receiver volume.
Use to enter the Message menu.

- 11 End & On/Off key**
Use to end a call.
Use to exit menus.
Use to turn the handset on/off.
- 13 Star & Ringer Off key**
Use to dial *.
Use to turn the ringer on/off.
- 15 Intercom key**
Use to make an intercom call.
Use to start a conference call.

- 12 Digit keys**
Use to dial digits.
Use to enter characters.
- 14 Hash, Keylock, & Pause key**
Use to dial #.
Use to enter a pause.
Use to lock the keypad.
- 16 Service key**
Use to enter the services menu.

THE BASE

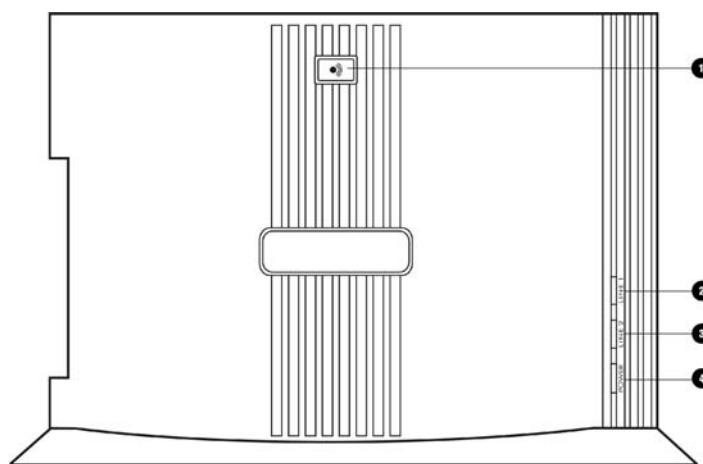

- | | |
|--|---|
| <p>1 Page key
Use to find handset(s).
Use to register handset(s).</p> <p>3 Line 2 indicator
Lit when line 2 is in use.</p> | <p>2 Line 1 indicator
Lit when line 1 is in use.</p> <p>4 Power indicator
Lit when base unit is powered on.</p> |
|--|---|

HANDSET ICONS

Each icon gives you a visual message of what is happening on your handset.

- | | |
|--|---|
| Signal strength | Battery level |
| Line 1 in use | Line 2 in use |
| Line 1 call record | Line 2 call record |
| Line 1 indicator | Line 2 indicator |
| Line 1 on hold (cannot be picked up from other handsets) | Line 1 on hold (can be picked up from other handsets) |
| Line 2 on hold (cannot be picked up from other handsets) | Line 2 on hold (can be picked up from other handsets) |
| Internal call indicator | Speaker on |
| Left and right arrows | New message |
| New missed call | New (repeated) missed call |
| Alarm clock on | Keypad locked |
| Volume | Melody |
| Line 1 ringer off | Number |
| Line 2 ringer off | Mode or status |
| Line 1 & 2 ringers off | Prefix insertion rule |

THE MENUS

Your phone offers a variety of features and functions grouped in the menus.

Browsing the menus

The main menu includes the SMS, Call Log, Setting, Advanced, Extras, and System menu.

- Press **MENU** to enter the main menu.
- Press **NAMES** to enter the phonebook menu.
- Press to enter the services menu.



TIP: Use UP and DOWN to navigate the menus.

About Your Phone



TIP: Quick Exit. Press  to exit from any menu instantly. All unconfirmed changes will not be save.

Taking a glance at the menus

*This menu only applies to a certain model or country group.

SMS	CALL LOG	SETTINGS	ADVANCED
Private	Missed	Sounds	Recall
Compose	Dialed	Line 1 Ringer	Pause
Inbox	Received	Line 2 Ringer	Prefix*
Outbox	Notification	Intercom Ringer	Call Barring
Profile	Call Timers	Key Tone	PABX
Logout	Last Call	Handset Tone	
Public	Dialed	Equalizer	
Compose	Received	Date And Time	
Inbox	Total	Date Format	
Outbox	Reset All	Date	
Setting	Reset	Time Format	
Close Service	Missed	Time	
Mailbox	Dialed	Handset Name	
Service Centre	Received	Language*	
Alert Tone	Notification	Call Services	
Template	VMWI	Do Not Disturb	
Memory Status	Log Option	Auto Answer	
	Log All	Contrast	
	Missed Only		
EXTRAS	SYSTEM	PHONEBOOK	SERVICES
Alarm Clock	Register	Private	View
Timer	Select Base	View Record	Reset
Stopwatch	Auto	New Entry	
	Base 1 ... 4	Quick Dial	
	Delete Handset	Memory Status	
	Line Matrix	Delete All	
	Line 1 In	Public	
	Line 2 In	View Record	
	Line 1 Out	New Entry	
	Line 2 Out	Memory Status	
	Ring Count	Delete All	
	Reset		
	Change PIN		
	Country Setting (for model with multiple-country settings only)		

Getting Started

CONNECTING YOUR PHONE

1. Connect the output plug of the mains adapter to the bottom of the base unit.
2. Connect the mains adapter to a standard wall outlet.
3. Connect the telephone line cords to the phone sockets (Line 1 & Line 2) on the side of the base unit and the wall phone sockets.

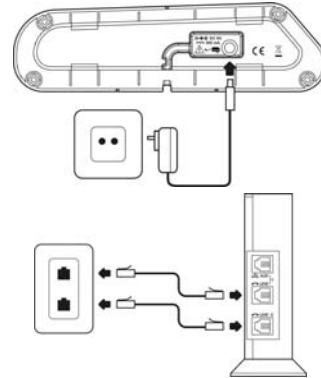

SMS is supported on Line 1 only. Connect the SMS-enabled PSTN telephone line cord to Line 1.

4. Connect the auxiliary device such as a Fax, eftpost terminal, phone, or answering system (not supplied) to the AUX socket.

The auxiliary corded phone maybe used on Line 1 for calls during power failure situation.

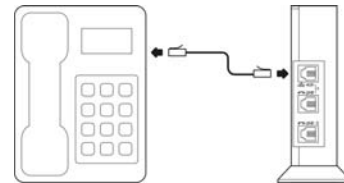

CONNECTING YOUR CHARGER

1. Connect the power adapter of the charger to a powerpoint.

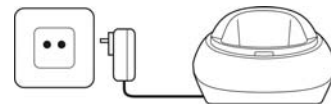

CHARGING YOUR HANDSET



WARNING: RISK OF EXPLOSION IF BATTERY IS REPLACED BY AN INCORRECT TYPE. Never use non-rechargeable batteries. Use recommended type supplied with this product. NiMH batteries must be disposed of in accordance with the applicable waste disposal regulations.



NOTE: Charge the handset(s) for 14 hours before initial use!



CAUTION: Check the batteries polarity when inserting the batteries. Incorrect polarity may damage the product.

1. Place the 2 rechargeable batteries (included) into the battery compartment.
2. Slide the battery door firmly into place.

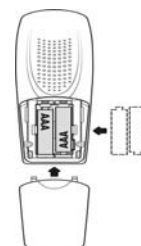

Call





- Place the handset on the charging cradle. **Charge for 14 hours before initial use.**



NOTE: Handset may get warm during initial charge. This is normal. The handset may take a few seconds to power up.

CHECKING THE BATTERY LEVEL

The battery icon displays the current battery level.

-  = 100% full
-  = 60% full
-  = 30% full
-  = Empty. Require charging.

Your handset may power down shortly if it is not charged after the battery is empty. If you are on the phone while the battery is nearly empty, you will hear warning tones. Your call maybe cut off shortly after the warning.

WALL MOUNTING THE BASE



CAUTION: Other wall mounting methods are not recommended and may damage the product.

Please use the following wall mount template to locate and install the mounting pins/screws if you prefer to wall mount your base unit. The dimensions are shown in millimeters (mm).

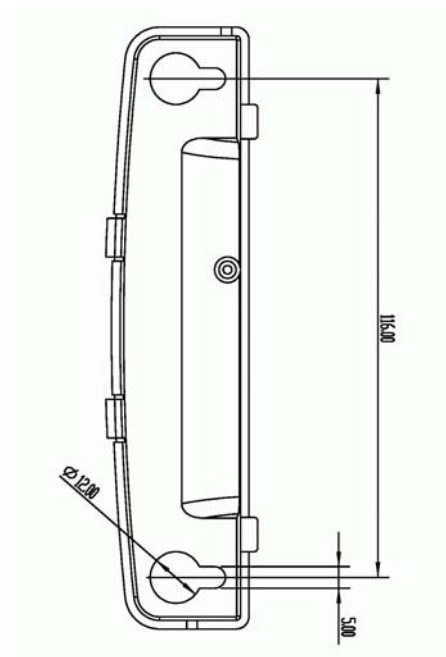

- Insert screws (not supplied) into the wall.

The recommended mounting screws are "Philips Pan Head Self-Tapping Screws" with diameter 4mm and length 20mm. The diameter of the screw head and the screw should not be greater than 12mm and 5mm respectively.

- Push the locking tabs of the wall mount bracket into the mounting holes at the back of the base unit.
- Align the mounting holes of the wall mount bracket with the wall posts.

- Slide the base unit down into place.

GREETING YOU WITH "HELLO"

At first start up, your handset welcomes you with a "Hello" message. At the "Hello" screen, set the country to start using the phone.

The Country menu is only available in models that support multiple-country settings. If the model has only one country setting, the "Hello" message will not be available and therefore you will not need to select the country setting before use.

Selecting your country

It is necessary to select the correct country for the phone to work properly according to your country's standards.

At the "Hello" screen,

- Press **>>** to navigate to your country.
- Press **OK** to confirm. Your phone is now ready to use.

To re-configure your country setting, see page 44.

WHAT IS STANDBY MODE?

Your phone is in standby mode when it is idle. The standby screen displays the handset name, the date and time, the signal icon, and the battery icon.

REGISTERING YOUR HANDSET

Registration allows communication between your base unit and handset(s). If your handset cannot communicate with its base, you will not be able to make any call or use some of the functions and features on the phone.



NOTE: Your S209 Twin pack handsets are registered at the factory. Follow the procedure below only if you have bought extra handsets or you have de-registered a handset.

To register your handset to an additional base unit, see *Registering your handset(s) with additional base* on page 44.

If your handset displays NOT REG, follow the steps below to register your handset.

- Press **REG**. REGISTER shall be highlighted.
- Press **OK** to confirm selection.
- Select the base number you want. Press **OK**. This base number will be assigned to the base unit you are about to register to.
- Enter the system PIN. Use **DELETE** to make correction.
- Press **OK** to confirm. Your handset starts searching for the base.
- Press **PAGE** on the base unit for 4 seconds. The registration process shall be completed within 30 seconds. If registration is successful, the signal icon  displays steadily. If registration failed, repeat the above procedure.



NOTE: Your base can register up to 9 handsets. After registering 9 handsets, your base unit registration memory is full. If you attempt to register an additional handset, you will hear a reject tone from the base. The registration process will be aborted.

CHECKING THE SIGNAL STRENGTH

The signal icon  displays the link status between your handset and the base unit.

Steady signal icon: Your handset and base unit are linked. They can communicate.

Flashing signal icon: Your handset and base unit have lost link. They are not able to communicate. Take your handset closer to the base unit to reconnect the link.

Call

If you move too far away from the base unit while you are on the phone, you will hear warning tones notifying you that your handset is almost out of range – lost link. Take your handset closer to the base unit or your call will be cut off shortly after the warning.



NOTE: If your handset has lost the link with the base, you will not be able to make or receive any call. In addition, you will not be able to carry out many of the phone functions and features.

SWITCHING YOUR HANDSET ON/OFF

Switching on your handset

1. Press . The handset may take a few seconds to power up.

Switching off your handset

2. Press and hold . The handset's screen turns off.



NOTE: Your handset cannot receive any call if the power is switched off.

SETTING THE CLOCK

Your phone has a calendar and digital clock. Set the date and time before initial use of the phone.

If the base's power resets, the clock resets to 12:00AM (for 12-hour format) and 00:00 (for 24-hour format), and the date resets to the factory default date.



TIP: Use UP and DOWN to navigate the menus.

Selecting the date format

1. Press **MENU**.
2. Select SETTINGS. Press **OK**.
3. Select DATE AND TIME. Press **OK**.
4. Select DATE FORMAT. Press **OK**.
5. Select the date format you want.
6. Press **OK** to confirm. The new setting is saved.

Setting the date

1. Press **MENU**.
2. Select SETTINGS. Press **OK**.
3. Select DATE AND TIME. Press **OK**.
4. Select DATE. Press **OK**.
5. Press **LEFT** or **RIGHT** to select the value for the Month/Day/Year.
6. Press **DOWN** to set the next item.
7. Press **OK** when finished. The new setting is saved.

Selecting the time format

1. Press **MENU**.
2. Select SETTINGS. Press **OK**.
3. Select DATE AND TIME. Press **OK**.
4. Select TIME FORMAT. Press **OK**.
5. Select the time format you want.
6. Press **OK** to confirm. The new setting is saved.

Setting the time

1. Press **MENU**.

2. Select **SETTINGS**. Press **OK**.
3. Select **DATE AND TIME**. Press **OK**.
4. Select **TIME**. Press **OK**.
5. Press **LEFT** or **RIGHT** to select the value for the Hour/Minute and AM/PM (for 12-hour format only).
6. Press **DOWN** to set the next item.
7. Press **OK** when finished. The new setting is saved.

Call



NOTE: Emergency Call. This cordless phone is not designed for making emergency telephone calls when the power fails. Alternative arrangements should be made for access to emergency services.





TIP: Use **UP** and **DOWN** to navigate the menus.

MAKING A CALL

This section describes the different ways to make a call.



NOTE: Signal Strength. Check the signal strength before making a call and during a call. For details, see *Checking the signal strength* on page 9.

1. Press  for line 1 or  for line 2.
2. Dial the phone number. The number displays on the screen and is dialed out.



NOTE: Call Timer. During a call, the call timer displays the talk time of your current call.



NOTE: Low Battery. During a call, you will hear warning tones if your handset is almost out of battery. Charge your handset as soon as possible or your call will be cut off. Placing the handset on the charger will end the call. For details, see *checking battery level* on page 8.

Pre-dialing

Pre-dialing lets you view and make changes to the number before making the call.

1. Enter the phone number. The number displays on the screen. You can make changes before dialing out.





TIP: Press **DELETE** to erase a digit.
Use **LEFT** and **RIGHT** to move the cursor.
Press and hold  to enter a pause. P displays on the screen.

2. Press  to dial out the call on line 1 or  to dial out on line 2.



TIP: Press **DIAL** to auto-select a free line to make the call.

Redialing the last number

1. Press  for line 1 or  for line 2.



Call

2. Press **REDIAL**. The last dialed number displays on the screen and is dialed out.

Calling from the dialed list



Each handset stores the last 10 numbers (up to 32 digits) you have dialed. The most recent dialed number is stored at the top of the list. For details on the dialed list, see

Call Log on page [30](#).

1. Press **LEFT** or **RIGHT** to enter the dialed list.
2. Select the number you want.
3. Press  to dial out the call on line 1 or  to dial out on line 2.

Calling from your phonebook



For details on the phonebook, see *Phonebook* on page [27](#).

1. Press **NAMES**.
2. Select the phonebook you want. Press **OK**.
3. Select **VIEW RECORD**. Press **OK**.
4. Select the phonebook record you want.
5. Press  to dial out the call on line 1 or  to dial out on line 2.

Calling from the call log

The call log stores dialed, received, and missed calls. For details about the call log, see

Call Log on page 30.

1. Press **MENU**.
2. Select CALL LOG. Press **OK**.
3. Select the call log you want. Press **OK**.
4. Select the record you want.
5. Press  to dial out the call on line 1 or  to dial out on line 2.

Speed dialing

Spend less time dialing! Speed dialing gives you the convenience of dialing a number by pressing a single key. To program a number for speed dialing, see *Assigning a speed dial key* on page 28.

To make a call using speed dialing, during standby,

1. Press and hold the assigned key. The number displays on the screen and is dialed out on a free line.

ENDING A CALL

1. Press  **OR**
Place the handset on the charger.

ANSWERING A CALL

When you receive a call, your phone rings.



TIP: When the phone is ringing, press **SILENT** to turn off the ringer for the incoming call.

To turn off the ringer for all calls, press and hold  during standby.  displays on the screen.

For details on ringer setting, see *Setting your handset's ringer* on page 34.

Call

If the call is from line 1,  and the indicator on  flash, press  to answer.

If the call is from line 2,  and the indicator on  flash, press  to answer.



NOTE: Caller ID Service. You must subscribe to your telephone operators service.



TIP: Missed Call Alert. When a call is missed, your phone displays a missed call notification. Press OK for more options.

DURING A CALL

This section describes the features that are available during a call.

Making a second call on the same line



1. Press  if you are on line1 or press  if you are on line 2. R displays on the screen.
2. Dial the number you want. The number displays on the screen and is dialed out.

Answering a second call on the same line



NOTE: 2nd Call waiting service. If you have subscribed to your telephone network operators Call Waiting Caller ID service, your phone will display the number of the second incoming call for a short period.while you are talking on the phone

During a call, your phone sounds a short beep periodically to notify you of an incoming call.

1. Press  if the call is from line1 or press  if the call is from line 2. You have put the first call on hold, and you are now connected to the second call.

toggling between two calls on the same line

1. Press **OPTIONS**.
2. Select **2ND CALL** to end the current call and connect to the other call. **OR** Select **TOGGLE** to put the current call on hold and connect to the other call.
3. Press **OK**.

Adjusting the earpiece volume

1. Press **UP** or **DOWN** to adjust the volume during a call.
2. Press **OK** when finished.

Muting the microphone

The mute feature allows you to speak to someone in the house privately.

1. Press **MUTE** during a call. The caller cannot hear you, but you can still hear the caller's voice.

Un-muting the microphone

1. Press **UNMUTE**. You can now communicate with the caller.

Using handsfree

The handsfree feature lets you talk on the phone without holding onto the handset.

Use the speaker to involve everyone in the room in the conversation. Use the headset to talk privately with the caller.

Turning the speaker on/off

1. Press **OPTIONS** during a call.
2. Select **SPEAKER**.
3. Press **OK**.



Using the headset

1. Plug the headset into the headset jack at the side of your handset.

DUAL LINE CALLS

Making a call on another line

While you are on a call, you can make a call on another line.



1. Press  for line 1 or  for line 2. Your call on the other line is placed on hold.
2. Dial the number you wish to call. The number displays on the screen and is dialed out.

Answering a call on another line

While you are on a call, you can answer a call from another line.

1. Press  if the call is from line 1 or press  if the call is from line 2. Your call on the other line is placed on hold. You are now connected to the caller from the other line.

Toggling between two calls on different lines

1. Press  to talk on line 1 or  to talk on line 2. The other line is placed on hold.

Intercom and Conference Calls

An intercom call is a call to another handset that shares the same base unit.

A conference call involves conversation between other handset(s) and outside caller(s).





TIP: Use UP and DOWN to navigate the menus.

CALLING ANOTHER HANDSET



NOTE: An intercom call can only involve 2 handsets.

1. Press .
2. Select the handset you want.
3. Press **OK**. Wait for the other party to answer your call.
4. Press  to cancel or end the intercom call.



TIP: To customize your intercom ringer, see *Setting your handset's ringer* on page 34.

While you are on the phone

While talking on the phone, you can call another handset.

1. Press  during the call.
2. Select the handset you want.
3. Press **OK**. Wait for the other party to answer your call.

To return to the outside caller

You have to end the intercom call first.

1. Press **OPTIONS**.
2. Select END INQUIRY.
3. Press **OK**.

TRANSFERRING A CALL

1. Press  during a call.
2. Select the handset you want. Press **OK**.



TIP: Quick Transfer. Press **TRANSFR**. Your handset returns to standby. If the other party does not answer within 30 seconds, the call will be directed back to your handset.

3. Press  after the other party answers your call. The outside call is now transferred to the other handset.

MAKING A CONFERENCE CALL



TIP: Conference Options. During any kind of conference calls, you can access the **OPTIONS** menu for other convenient functions and features.

Making a dual line conference call

A dual line conference call is a call between you and 2 outside callers using both telephone lines on your phone.

You are on a call on both line 1 and 2, and you want to talk to both parties at the same time.

1. Press **OPTIONS** while on the call on line 1 or line 2.
2. Select CONFERENCE.
3. Press **OK**. You are now on a dual line conference call.



Making a 3-way conference call

A 3-way conference call is a call between you, an outside caller, and another handset user in your house.



NOTE: A 3-way conference call requires 2 handsets.

You are talking on the phone with an outside caller, and you want to involve another handset user in this conversation.

1. Press  during your call with the outside caller.
2. Select the handset you want.
3. Press **OK**. Wait for the other party to answer your call.
4. Press **OPTIONS** after the other party picks up the call.
5. Select CONFERENCE.
6. Press **OK**. You are now on a 3-way conference call.
7. Press  to end the conference call.



Making a 4-way conference call

A 4-way conference call is a call between you, 2 outside callers, and another handset user in the house.



NOTE: A 4-way conference call requires 2 handsets.

You are on dual line conference call, and you want to involve another handset user in your house in this conversation.

1. Press  while on the dual line conference call.
2. Select the handset you want.
3. Press **OK**. Wait for the other party to answer your call.
4. Press **OPTIONS** after the other party picks up the call.
5. Select CONFERENCE.
6. Press **OK**. You are now on a 4-way conference call.
7. Press  to end the conference call.

Text and Numbers

You can enter text and numbers for handset name, phonebook record, services record, text messaging, and others.

CHANGING THE LETTER CASE

The default setting is upper case.

1. Press  during editing. The next letter you enter will be in the alternate case.

ENTERING TEXT AND NUMBERS

1. Find the key with the character you want.
2. Press it as many times as needed for the character to display on the screen.



TIP: Use LEFT and RIGHT to move the cursor.

Figure 1: Upper case input table

Key	Characters											
0	0	.	,	:	;	?	!	@	"	'	`	%
1	space	1	\$	£	€	¥	{	}	\$	i	¿	
2	A	B	C	2	Á	À	Ä	Æ	Ç			
3	D	E	F	3	Ð	É	È	Δ				
4	G	H	I	4	Í	Ì	Γ					
5	J	K	L	5	Λ	Κ						
6	M	N	O	6	Ñ	Ó	Ò	Ö	Ø	Ω		
7	P	Q	R	S	7	Β						
8	T	U	V	8	Ú	Ù	Θ	Ξ	Π	Φ	Ψ	
9	W	X	Y	Z	9	[]	\	^		~	
*	*	#	+	-	_	=	()	<	>	/	&

Figure 2: Lower case input table

Key	Characters											
0	0	.	,	:	;	?	!	@	"	'	`	%
1	space	1	\$	£	€	¥	{	}	\$	i	¿	
2	a	b	c	2	á	À	ä	æ	ç			
3	d	e	f	3	Ð	É	È	Δ				
4	g	h	i	4	Í	Ì	Γ					
5	j	k	l	5	Λ	Κ						
6	m	n	o	6	ñ	ó	ò	ö	ø	Ω		
7	p	q	r	s	7	Β						
8	t	u	v	8	Ú	Ù	Θ	Ξ	Π	Φ	Ψ	
9	w	x	y	z	9	[]	\	^		~	
*	*	#	+	-	_	=	()	<	>	/	&

ERASING TEXT AND NUMBERS

Erasing a single character

1. Press **DELETE** to delete the character left of the cursor.

Erasing all characters

1. Press and hold **DELETE** to delete all the characters on screen.

SMS Text Messaging (Australia only)

SMS, short messaging service, is a service for sending short text messages to other phones through a service centre. For details about service centre, refer to *Setting up SMS service centres* on this page. At time of printing this user guide, SMS is only available in Australia and only for calls made within the Telstra network.



NOTE: SMS Service. Consult and subscribe from your service provider. SMS is supported on line 1 only.



TIP: SMS Menu Shortcut. Press and hold  during standby. Use UP and DOWN to navigate the menus.

ACTIVATING SMS

If the SMS service is de-activated,

1. Press **MENU**.
2. Select SMS. Press **OK**.
3. Press **ACTIVE**.
4. Enter the system PIN.
5. Press **OK** to confirm. SMS is activated.

DEACTIVATING SMS

1. Press **MENU**.
2. Select SMS. Press **OK**.
3. Select SETTINGS. Press **OK**.
4. Select CLOSE SERVICE. Press **OK**. CONFIRM? is displayed.
5. Press **YES** to confirm.
6. Enter the system PIN.
7. Press **OK** to confirm. SMS is deactivated.

SETTING UP SMS SERVICE CENTRES

The text messages are sent and received through the SMS service centre. To assist in set up the service centre numbers have been pre-programmed. These should not need to be changed.

SMS Centre 1 "183201983391"

SMS Centre 2 "01983391"



NOTE: SMS Service. If you normally have your Calling Number display blocked you must remove 1832 in front of 01983391 in the SMS centre otherwise you can not send a text message. However you should be aware that this will allow presentation of your phone number to the called party.

If for some reason the service center numbers are changed you will need to reenter the service centre number before you can start sending and receiving messages. For the service centre number(s), consult your service provider.

Setting up the service centre

1. Press **MENU**.
2. Select SMS. Press **OK**.
3. Select SETTINGS. Press **OK**.
4. Select SERVICE CENTRE. Press **OK**.
5. Select SENDING or RECEIVING. Press **OK**.

Option	What is it?
Sending	The service centre for outgoing messages.

SMS Text Messaging

Receiving The service centre for incoming messages.

6. Select a service centre. Press **OK**.
7. Enter the service centre number. Press **SAVE**.
Repeat from step 5 to add more service centres.



NOTE: Your phone supports up to 4 “sending” and 4 “receiving” service centres.

8. For the “sending” service centre, after you have entered the number for the centre, the DEFAULT SC menu will be displayed.
Select a default sending service centre. Press **OK**.
All messages will be sent through the default service centre.

ABOUT MAILBOXES

Your phone supports 1 public mailbox and 9 private mailboxes. The public mailbox can be shared by everyone. The private mailboxes are each protected by a customized password. Each mailbox (public or private) has an Inbox and Outbox.

	What is it?
Inbox	Store received messages.
Outbox	Store saved (to be sent later) messages, sent messages, and messages with sending error.

Each mailbox has a name and sub-address. A sub-address is a 1-digit extension number that your caller adds to your telephone number. It allows the caller to send you a text message directly to your personal mailbox. For example, Sam's mailbox sub-address is '5'. If Tom wants to send a text message directly to Sam, then he has to add the digit '5' to the phone number or specify the sub-address '5' when sending the text message. To find out your mailbox sub-address, refer to *Activating a private mailbox* on page 20.



NOTE: Sub-address Subscription. Consult and subscribe this service from your service provider.

ORGANIZING THE PUBLIC MAILBOX

The public mailbox can be accessed by anyone using any of the handsets. You can change the sub-address and the access matrix.

Changing sub-address

You can change the public mailbox sub-address to an unassigned sub-address.



NOTE: Changing the sub-address may affect SMS text message receiving.

1. Press **MENU**.
2. Select SMS. Press **OK**.
3. Select SETTINGS. Press **OK**.
4. Select MAILBOX. Press **OK**.
5. Enter the system PIN. Press **OK** to confirm.
6. Select the public mailbox. Press **OK**.
7. Select SUBADDRESS. Press **OK**.
8. Select the sub-address you want.
9. Press **OK** to confirm. The new setting is saved.

Defining access matrix

The access matrix feature allows you to assign privileges and restrictions on selected handsets from accessing the public mailbox. There are 2 access matrix options: on or off.

Option	What is it?
On	The selected handset cannot access the public mailbox.
Off	The selected handset can access the public mailbox.

1. Press **MENU**.
2. Select SMS. Press **OK**.
3. Select SETTING. Press **OK**.
4. Select MAILBOX. Press **OK**.
5. Enter the system PIN. Press **OK** to confirm.
6. Select the public mailbox. Press **OK**.
7. Select ACCESS MATRIX. Press **OK**.
8. Select the handset to modify. Press **OK**.
9. Select the new setting.
10. Press **OK** to confirm. The new setting is saved.

ORGANIZING PRIVATE MAILBOX

A private mailbox is your personal mailbox. You can change the name and password.

Activating a private mailbox

1. Press **MENU**.
2. Select SMS. Press **OK**.
3. Select SETTINGS. Press **OK**.
4. Select MAILBOX. Press **OK**.
5. Enter the system PIN. Press **OK** to confirm.
6. Select a free mailbox. Press **OK**.



TIP: Sub-address. The digit in front of each mailbox is the sub-address. For example, 1-FREE.

7. Enter the name for the new mailbox. Press **OK**.
8. Enter a password (up to 8 digits) for the mailbox. Press **OK**.
9. Enter the password again for verification.
10. Press **OK** to confirm. The new mailbox is activated.

Logging in to a mailbox

Log in to your mailbox to access the supported functions. One handset can only log in to one private mailbox at a time. Log out from the existing mailbox to access another one, refer to *Logging out of a mailbox* on page 21.

1. Press **MENU**.
2. Select SMS. Press **OK**.
3. Select PRIVATE. Press **OK**. UNKNOWN is displayed.
4. Press **LOGIN**.
5. Select the mailbox you want. Press **OK**.
6. Enter the mailbox password. Press **OK** to confirm.

Logging out of a mailbox

If you do not want others to access your mailbox, log out after using it.

1. Press **MENU**.
2. Select SMS. Press **OK**.
3. Select the mailbox you want to log out from. Press **OK**.

SMS Text Messaging

4. Select LOGOUT. Press **OK**. CONFIRM? is displayed.
5. Press **YES** to confirm. You have logged out from the mailbox.

Changing mailbox name

1. Press **MENU**.
2. Select SMS. Press **OK**.
3. Select SETTINGS. Press **OK**.
4. Select MAILBOX. Press **OK**.
5. Enter the system PIN. Press **OK** to confirm.
6. Select the mailbox you want. Press **OK**.
7. Select CHANGE NAME. Press **OK**.
8. Edit the name.
9. Press **OK** when finished. The new setting is saved.

Changing mailbox password

1. Press **MENU**.
2. Select SMS. Press **OK**.
3. Select the mailbox you have already logged in to. Press **OK**.
4. Select PROFILE. Press **OK**.
5. Select PASSWORD. Press **OK**.
6. Enter the new password (up to 8 digits). Press **OK** to confirm.
7. Enter the new password again for verification.
8. Press **OK** to confirm. The new password for the mailbox is saved.

Closing a mailbox

You can permanently close a mailbox if you no longer want to use it anymore.

1. Press **MENU**.
2. Select SMS. Press **OK**.
3. Select SETTINGS. Press **OK**.
4. Select MAILBOX. Press **OK**.
5. Enter the system PIN. Press **OK** to confirm.
6. Select the mailbox to close. Press **OK**.
7. Select CLOSE MAILBOX. Press **OK**. CONFIRM? is displayed.
8. Press **OK** to confirm. The mailbox is closed.



NOTE: After closing a mailbox, all messages in the mailbox will be deleted and cannot be recovered.

SETTING NEW MESSAGE ALERT

When you received a new text message, your phone displays a new SMS notification. Press **OK** for more options.



NOTE: Private Mailbox SMS Alert. You will only receive alert from the private mailbox that you are currently logged in to.



NOTE: Public Mailbox SMS Alert. You will only receive alert from the public mailbox if you are not currently logged in to a private mailbox.

Your phone can also give you an audio alert when a new text message is received.

1. Press **MENU**.
2. Select SMS. Press **OK**.
3. Select SETTINGS. Press **OK**.
4. Select ALERT TONE. Press **OK**.

5. Select the new setting.
6. Press **OK** to confirm. The new setting is saved.

READING AND RETRIEVING MESSAGES

1. Select INBOX after you log in to a mailbox.
2. Press **DETAILS** to view the entire message.

RETURNING A CALL TO THE SENDER

1. Press  or  while reading a message in detail **then select and confirm REPLY or OPTION**. Your call will be connected to the sender.

COMPOSING AND SENDING MESSAGES



NOTE: Incoming Call. If there is an incoming call when you are composing a message, your phone will automatically save the draft in the outbox. You can retrieve the draft after answering the call.

Your phone can only save the first 160 characters of a long message in a draft. For backup, you need to save the entire message manually before an incoming call comes in.

Composing messages

A single text message can have up to 160 characters. If your message is longer than 160 characters, it is considered a long message and maybe handled differently by your service provider. A long message can have up to 612 characters. For details, consult your service provider. There may be a cost difference on sending long messages.

1. Press **MENU**.
2. Select SMS. Press **OK**.
3. Select and log in to the mailbox that you want to send the message from.
4. Select COMPOSE.



TIP: Send as E-mail or Fax. Before composing your message, press **INSERT** to insert an email address or fax number to send your message as an email or fax.

5. Enter your message.



NOTE: Text and Number Editing. See *Text and Numbers* on page 17.



TIP: Options while composing. While composing your message, press **OPTIONS** to access more functions. Your phone might not support all options.
 Select **SAVE** to send your message later.
 Select **LANGUAGE** to change the input language.
 Select **TEMPLATE** to insert a pre-programmed message.
 Select **EXIT COMPOSE** to cancel composing.

6. Press **OPTIONS** when you finish writing the message.
7. Select **SEND**. Press **OK**.
8. Enter the number. Press **OK**. Your message is sent. If you have subscribed for extra SMS services, follow the on-screen instruction.



NOTE: Extra SMS Services. Your service provider may offer extra services such as status report and message sending expiry time. Consult and subscribe these services from your service provider.

SMS Text Messaging

Modifying a template message

Your phone comes with 5 pre-programmed template messages. You can insert these messages while you are composing. You can also edit these messages.

1. Press **MENU**.
2. Select SMS. Press **OK**.
3. Select TEMPLATE. Press **OK**.
4. Select the template message you want.
5. Press **DETAILS** to view the entire template.
6. Press **EDIT**. Start editing.
7. Press **SAVE** when finished.



NOTE: After reset, modified templates will not be restored back to the factory pre-programmed ones.

Replying a message

1. Press **OPTIONS** while reading the message.
2. Select REPLY. Press **OK**.
3. Enter your message.
4. Press **OPTIONS** when you finish writing the message.
5. Select SEND. Press **OK**.
6. Edit the number if necessary. Press **SEND**. Your message is sent. If you have subscribed for extra SMS services, follow the on-screen instruction.

Forwarding a message

1. Press **OPTIONS** while reading the message.
2. Select FORWARD. Press **OK**.
3. Enter the recipient's number. Press **SEND**. Your message is sent. If you have subscribed for extra SMS services, follow the on-screen instruction.

Copying a message

You can send an extra copy of a message from one mailbox to the other.

1. Press **OPTIONS** while reading the message.
2. Select COPY TO. Press **OK**.
3. Select the mailbox you want to copy to.
4. Press **OK**. Your message is copied.

Moving a message

You can move a message from one mailbox to the other. The moved message will be deleted from the original mailbox.

1. Press **OPTIONS** while reading the message.
2. Select MOVE TO. Press **OK**.
3. Select the mailbox you want to move to.
4. Press **OK**. Your message is moved.

DELETING A MESSAGE

1. Press **OPTIONS** while reading the message.
2. Select DELETE. Press **OK**. CONFIRM? is displayed.
3. Press **YES** to confirm. The message is deleted.

DELETING ALL MESSAGES

1. Press **OPTIONS** while reading any of the messages in the mailbox.
2. Select **DELETE ALL**. Press **OK**. **CONFIRM?** is displayed.
3. Press **YES** to confirm. All messages are deleted.

CHECKING THE MAILBOX MEMORY STATUS

Your phone keeps track of the number of messages you have stored on the phone. You can check the memory status and find out how many messages you can still receive and store.

1. Press **MENU**.
2. Select **SMS**. Press **OK**.
3. Select **MEMORY STATUS**. Press **OK**. The status is displayed.
4. Press **OK** when finished.



Voicemail Indication and Notifications

Voicemail indication and notifications are voicemail-related services. These services are provided by your service provider. For details and subscription, consult your service provider.



TIP: Use **UP** and **DOWN** to navigate the menus.

VOICEMAIL INDICATION

Voicemail indication is a visual voicemail alert. On this phone, you see an envelope  icon when there is a voicemail waiting in your mailbox(es). The envelope  icon may also appear if you have received other new messages. For details, see *New message indication* on page 42.

Retrieving voicemail(s)

To retrieve your voicemail(s), consult your service provider.

Clearing the voicemail indicator

After checking your voicemail(s), your service provider will clear the voicemail indicator  or if need be you can clear it manually from the menu.

1. Press **MENU**.
2. Select CALL LOG. Press **OK**.
3. Select RESET. Press **OK**.
4. Select VMWI. Press **OK**. CONFIRM? is displayed.
5. Press **YES** to confirm. The voicemail indicator is cleared.

NOTIFICATIONS

Notification is an enhancement to the voicemail indication service. Notification provides a visual voicemail alert  and the caller number.

Reviewing and retrieving notification(s)

1. Press **MENU**.
2. Select CALL LOG. Press **OK**.
3. Select NOTIFICATION. Press **OK**.
4. Select the record you want.
5. Press  or  to retrieve the message(s). Follow the instruction from the service centre.

Deleting a notification record

1. Press **MENU**.
2. Select CALL LOG. Press **OK**.
3. Select NOTIFICATION. Press **OK**.
4. Select the record you want to delete.
5. Press **DELETE**. CONFIRM? is displayed.
6. Press **YES** to confirm. The record is deleted.

Deleting all notification records

1. Press **MENU**.
2. Select CALL LOG. Press **OK**.
3. Select RESET. Press **OK**.
4. Select NOTIFICATION. Press **OK**. CONFIRM? is displayed.
5. Press **YES** to confirm. All records are deleted.

Phonebook

Your phone has 2 phonebooks providing you with convenience and privacy. Each phonebook record can have a name of up to 15 characters long and a number of up to 32 digits long.

	What is this?	Stored records
Public	It is a shared phonebook stored in the base. All handsets sharing the same base unit can access the public phonebook.	Up to 50
Private	It is a personal phonebook stored on each handset. Each handset has its own private phonebook.	Up to 100



TIP: Use UP and DOWN to navigate the menus.

VIEWING THE PHONEBOOK

1. Press **NAMES** to enter the phonebook menu.
2. Select the phonebook you want – Private or Public. Press **OK**.
3. Select VIEW RECORD. Press **OK**.
4. Select the record you want, and press **DETAILS** to view the information of the record.

Searching a record

You can search the phonebook by scrolling or by searching the first character.

Searching by scrolling

1. While at the phonebook, press UP or DOWN to scroll.

Searching by the first character

1. While at the phonebook, press the digit key that contains the character that you want to search.

During a call

You can access the private phonebook during a call.

1. Press **OPTIONS** during a call.
2. Select PHONEBOOK. Press **OK**.

CALLING FROM THE PHONEBOOK



You can make a call directly from the phonebook while you are viewing it.

Calling directly from the phonebook

See *Calling from your phonebook* on page 13.

During a call

You can access the private phonebook during a call and make another call.

1. Press **OPTIONS** during a call.
2. Select PHONEBOOK. Press **OK**.
3. Select the record you want.
4. Press  for line 1 or  for line 2. Your call on the other line is placed on hold.

Call Log



TIP: You can save information such as an account number, password, etc. as a phonebook record. For example, when you are prompted to enter the password during telephone banking, you can simply select the record, and send out the number on the same line.



NOTE: 2nd Call Service. Consult and subscribe from your service provider.

Editing before calling

You can make changes, such as inserting a PABX prefix or international code, before dialing out a record.

1. Press **OPTIONS** while viewing the details of a phonebook record.
2. Select USE NUMBER. Press **OK**.
3. Edit the number.
4. Press to dial out the call on line 1 or to dial out on line 2.



TIP: Press **DIAL** to auto-select a free line to make the call.

ADDING A RECORD



NOTE: Memory Full. If your phonebook is full, a notification displays. Delete unnecessary records before adding new ones.

1. Press **NAMES** to enter the phonebook menu.
2. Select the phonebook you want – Private or Public. Press **OK**.
3. Select NEW ENTRY. Press **OK**.
4. Enter the name. Press **OK**.



NOTE: Text and Number Editing. See *Text and Numbers* on page 17.



NOTE: Duplicate Name. Phonebook records with identical names cannot be saved.

5. Enter the number. Press **OK**.
For the public phonebook, your new record is saved.
For the private phonebook, go to step 6.



TIP: Pause. Press and hold to insert a pause.

6. Press **LEFT** or **RIGHT** to select a VIP melody for the record.



TIP: VIP Melody. If you have assigned a VIP melody for a private phonebook record, the selected melody will be played when you receive a call from this caller. You can tell who is calling when the phone rings. This feature only works if you have Caller ID service.

7. Press **OK**. Your new record is saved.

Copying a record

You can copy a private phonebook record to the public phonebook and vice versa.

1. Press **OPTIONS** while viewing the details of a phonebook record.
2. Select TO PRIVATE or TO PUBLIC. Press **OK**.
3. Edit the name if necessary. Press **OK**.
4. Edit the number if necessary. Press **OK**.
If copying to the public phonebook, your record is copied.
If copying to the private phonebook, go to step 5.
5. Press **LEFT** or **RIGHT** to select a VIP melody for the record.
6. Press **OK**. Your record is copied.

EDITING A RECORD

1. Press **OPTIONS** while viewing the details of a phonebook record.
2. Select EDIT. Press **OK**.
3. Edit the name. Press **OK**.
4. Edit the number. Press **OK**.
For the public phonebook, your edited record is saved.
For the private phonebook, go to step 5.
5. Press **LEFT** or **RIGHT** to select a VIP melody for the record.
6. Press **OK**. Your edited record is saved.

DELETING A RECORD

1. Press **OPTIONS** while viewing the details of a phonebook record.
2. Select DELETE. Press **OK**. CONFIRM? is displayed.
3. Press **YES** to confirm. The record is deleted.

DELETING ALL RECORDS

1. Press **NAMES** to enter the phonebook menu.
2. Select the phonebook you want – Private or Public. Press **OK**.
3. Select DELETE ALL. Press **OK**. CONFIRM? is displayed.
4. Press **YES** to confirm. All records are deleted.

USING SPEED DIAL

Spend less time dialing! Speed dialing gives you the convenience of dialing a number in your private phonebook by pressing a single key. This is a private phonebook feature only.

Assigning a speed dial key

The digit keys [4] to [9] can each be used as a one touch speed dial key.

1. Press **NAMES** to enter the phonebook menu.
2. Select PRIVATE. Press **OK**.
3. Select QUICK DIAL. Press **OK**. The top row displays the key currently selected.
4. Press **UP** or **DOWN** to select a speed dial key you want.
5. If the key is EMPTY, press **CHANGE**.
If a phonebook record is already assigned to the key, press **OPTIONS**. Select CHANGE, and then press **OK**.
6. Select the phonebook record for the speed dial key.
7. Press **DETAILS**.
8. Press **OK**. The speed dial key is programmed.

Call Log

Making a call

After assigning a speed dial key, you can start making calls using speed dial.

1. Press and hold the assigned key during standby. The number displays on the screen and is dialed out on a free line.

Cancelling a speed dial key

If you no longer wish to use a speed dial key, you can cancel the key.

1. Press **OPTIONS** while viewing the selected speed dial key.
2. Select **DELETE**. Press **OK**. **CONFIRM?** is displayed.
3. Press **YES** to confirm. The speed dial key is cancelled.

CHECKING THE MEMORY STATUS

Your phone keeps track of the number of records you have stored on the phone. You can check the memory status and find out how many records you can still store.

1. Press **NAMES** to enter the phonebook menu.
2. Select the phonebook you want – Private or Public. Press **OK**.
3. Select **MEMORY STATUS**. Press **OK**. The status is displayed.
4. Press **OK** when finished.

Call Log

The call log stores the call history of all the missed, received, and dialed calls.

Calls	What is this?	Stored records
Missed	Calls that you received but did not answer.	Up to 70
Received	Calls that you received and answered.	Up to 30
Dialed	Calls that you have made.	Up to 10

The call history includes information of the caller name, number, call time, and date.

The call log also saves a call duration summary for the last call, each individual call log (received, dialed), and all calls.



TIP: Use **UP** and **DOWN** to navigate the menus.

VIEWING THE CALL RECORDS

1. Press **MENU**.
2. Select **CALL LOG**. Press **OK**.
3. Select the call log you want. Press **OK**.
4. Select the call record you want. Press **DETAILS** to view the details of the record.



TIP: Call Log Shortcut.

Missed Call Log. Press **UP** or **DOWN** during standby to enter the **MESSAGE** menu, and then select **MISSED CALLS**.

Dialed Call Log. Press **LEFT** or **RIGHT** during standby.

MAKING A CALL

Returning a call



To return a call from the missed or received call logs, see *Calling from the call log* on [page 13](#).

Redialing a call

To make a call that you have made previously, see *Calling from the dialed list* on [page 13](#).

Editing before calling

You can make changes, such as inserting a PABX prefix or international code, before dialing out a record.

1. Press **OPTIONS** while viewing the details of a call record.
2. Select **USE NUMBER**. Press **OK**.
3. Edit the number.
4. Press  to dial out the call on line 1 or  to dial out on line 2.



TIP: Press **DIAL** to auto-select a free line to make the call.

Sending a text message

1. Press **OPTIONS** while viewing the details of a call record.
2. Select **SEND SMS**. Press **OK**.
For details on composing a text message, refer to *Composing messages* on [page 23](#).

Call Log

SAVING A CALL RECORD TO YOUR PHONEBOOK

1. Press **OPTIONS** while viewing the details of a call record.
2. Select TO PRIVATE or TO PUBLIC. Press **OK**.
3. Edit the name if necessary. Press **OK**.
4. Edit the number if necessary. Press **OK**.
If saving to the public phonebook, your record is saved.
If saving to the private phonebook, go to step 5.
5. Press **LEFT** or **RIGHT** to select a VIP melody for the record.
6. Press **OK**. Your record is saved.

DELETING A CALL RECORD

1. Press **OPTIONS** while viewing the details of a call record.
2. Select DELETE. Press **OK**. CONFIRM? is displayed.
3. Press **YES** to confirm. The record is deleted.

DELETING ALL RECORDS

1. Press **MENU**.
2. Select CALL LOG. Press **OK**.
3. Select RESET. Press **OK**.
4. Select the call log you want. CONFIRM? is displayed.
5. Press **YES** to confirm. All records are deleted.

CALL TIMER

The call time is the duration of the calls you have made and received. It helps you keep track of how long you have talked on the phone. The call durations for the last call, each individual call log (received, dialed), and all calls are saved.

Reviewing the call timer

1. Press **MENU**.
2. Select CALL LOG. Press **OK**.
3. Select CALL TIMERS. Press **OK**.
4. Select the call log you want. Press **OK**.

Resetting the call timer

1. Press **MENU**.
2. Select CALL LOG. Press **OK**.
3. Select CALL TIMERS. Press **OK**.
4. Select RESET ALL. Press **OK**. CONFIRM? is displayed.
5. Press **YES** to confirm. The call timers for all the call logs are cleared.

LOG OPTION

You can customize your call log to tailor to your needs. You can choose to save the call history for missed and received calls (LOG ALL) or missed calls only (MISSED ONLY).

1. Press **MENU**.
2. Select CALL LOG. Press **OK**.
3. Select LOG OPTION. Press **OK**.
4. Select the option you want. Press **OK**.

Services Directory

Help is only a "key-press" away.

The services directory stores up to 20 service records. Your service provider can store some commonly used service commands, such as call forwarding, call centre, voicemails, on your phone. For details consult your service provider.

Each service record can have a name of up to 15 characters long and a number of up to 32 digits long.





TIP: Use UP and DOWN to navigate the menus.



VIEWING THE DIRECTORY

1. Press .
2. Select VIEW. Press **OK**.
3. Select the service record you want. Press **DETAILS** for more information.

CALLING FROM THE DIRECTORY

1. Press .
2. Select VIEW. Press **OK**.
3. Select the service record you want.
4. Press  to dial out the call on line 1 or  to dial out on line 2.



TIP: Service Record Speed Dial. Digit keys [1] and [2] are assigned speed dial keys for service records 1 and 2 respectively. Press and hold  or  during standby to dial out service record 1 or 2.

ADDING A RECORD

You can add other commonly used service numbers in your phone.

1. Press .
2. Select VIEW. Press **OK**.
3. Select an EMPTY service record. Press **DETAILS**.
4. Press **EDIT**.
5. Enter the name. Press **OK**.



NOTE: Text and Number Editing. See *Text and Numbers* on page 17.

6. Enter the number.
7. Press **OK**. Your new record is saved.



TIP: Pause. Press and hold  to insert a pause.

Services Directory

EDITING A RECORD



NOTE: Service records pre-set by the factory cannot be edited.

1. Press **OPTIONS** while viewing the details of a service record.
2. Select EDIT. Press **OK**.
3. Edit the name. Press **OK**.
4. Edit the number.
5. Press **OK**. Your edited record is saved.

DELETING A RECORD



NOTE: Service records pre-set by the factory cannot be deleted.

1. Press **OPTIONS** while viewing the details of a service record.
2. Select DELETE. Press **OK**. CONFIRM? is displayed.
3. Press **YES** to confirm. The record is deleted.

DELETING ALL RECORDS

1. Press . A small icon of a button with a circular arrow, representing a reset function.
2. Select RESET. Press **OK**. CONFIRM? is displayed.
3. Press **YES** to confirm. All records are deleted.



NOTE: Service records pre-set by the factory cannot be deleted.

Custom Options

Make this your handset – change the look and sound to suit your needs and tastes. From the display to sound, this section shows you how to set your preference.



TIP: Use **UP** and **DOWN** to navigate the menus.

PERSONALIZING YOUR PHONE'S DISPLAY

Naming your handset

Every handset can have its own name. It displays on the screen during standby.

1. Press **MENU**.
2. Select **SETTINGS**. Press **OK**.
3. Select **HANDSET NAME**. Press **OK**.
4. Edit the name.
5. Press **OK** when finished. The new setting is saved.

Setting your language

This section only applies to model(s) with multiple language support. This menu is suppressed in model(s) with single language support.

Language is the text you see on the screen.

1. Press **MENU**.
2. Select **SETTINGS**. Press **OK**.
3. Select **LANGUAGE**. Press **OK**.
4. Select the new setting.
5. Press **OK** when finished. The new setting is saved.

Adjusting LCD contrast

Contrast is the intensity of the text and background colour displayed on the screen. Adjusting the contrast changes the darkness of the text and background colour.

1. Press **MENU**.
2. Select **SETTINGS**. Press **OK**.
3. Select **CONTRAST**. Press **OK**.
4. Select the new setting. You see the new contrast while scrolling.
5. Press **OK** when finished. The new setting is saved.

PERSONALIZING YOUR PHONE'S SOUNDS

Setting your handset's ringer

Your handset has 3 ringers: line 1 ringer, line 2 ringer, intercom ringer. You can change the melody and volume of each ringer.

1. Press **MENU**.
2. Select **SETTINGS**. Press **OK**.
3. Select **SOUNDS**. Press **OK**.
4. Select the ringer you want.
5. Press **LEFT** or **RIGHT** to select the volume level.
6. Press **DOWN** to set the next item.
7. Press **LEFT** or **RIGHT** to select the melody.
8. Press **OK** when finished. The new setting is saved.

Custom Options

Setting the key tone

Key tone is the sound you hear when you press a key on your handset.

1. Press **MENU**.
2. Select **SETTINGS**. Press **OK**.
3. Select **SOUNDS**. Press **OK**.
4. Select **KEY TONE**. Press **OK**.
5. Select the new setting.
6. Press **OK** when finished. The new setting is saved.

Setting the handset tones

Handset tones will sound upon a successful or unsuccessful operation.

1. Press **MENU**.
2. Select **SETTINGS**. Press **OK**.
3. Select **SOUNDS**. Press **OK**.
4. Select **HANDSET TONE**. Press **OK**.
5. Select the new setting.
6. Press **OK** when finished. The new setting is saved.

Enhancing the audio quality

Your phone has an equalizer just like your home stereo system. The equalizer improves the receiver's sound quality by altering the treble or bass setting.

1. Press **MENU**.
2. Select **SETTINGS**. Press **OK**.
3. Select **SOUNDS**. Press **OK**.
4. Select **EQUALIZER**. Press **OK**.
5. Select the new setting.
6. Press **OK** when finished. The new setting is saved.

Your Digital Assistant

Your handset is not only a phone, but your best assistant. From the alarm clock to the countdown timer, it can assist you in many ways.



TIP: Use UP and DOWN to navigate the menus.

THE ALARM CLOCK

Use your phone as an alarm clock to wake you up from your sleep. You can have different alarm settings for each handset.

Setting the alarm clock

1. Press **MENU**.
2. Select EXTRAS. Press **OK**.
3. Select ALARM CLOCK. Press **OK**.
4. Select ON. Press **OK**.
5. Press **LEFT** or **RIGHT** to select the hour/minute.
6. Press **DOWN** to set the next item.
7. Press **OK** when finished. The alarm clock is set. You see an alarm icon  during standby.

Turning off the alarm clock

When the alarm clock rings

1. Press **STOP** to turn off the alarm clock **OR**
Press **SNOOZE**. The alarm clock will ring again in 10 minutes.



NOTE: If you do not press any key after the alarm clock rings for 1 minute, it will snooze and ring again in 10 minutes. The alarm clock will snooze for 5 times only.

Before the alarm clock rings

1. Press **MENU**.
2. Select EXTRAS. Press **OK**.
3. Select ALARM CLOCK. Press **OK**.
4. Select OFF. Press **OK**.

THE STOPWATCH

The stopwatch allows you to measure the exact timing of an event.

Starting the stopwatch

1. Press **MENU**.
2. Select EXTRAS. Press **OK**.
3. Select STOPWATCH. Press **OK**.
4. Press **START** to start the stopwatch.



TIP:

Press **PAUSE** to stop the stopwatch temporarily.
Press **RESUME** to restart the stopwatch from the previous time.
Press **STOP** to stop the stopwatch.
Press **RESET** to set the stopwatch to 000:00:00:0.
Press **CANCEL** to exit from the stopwatch.

Your Digital Assistant

THE COUNTDOWN TIMER

The timer keeps track of the time and alerts you when the time ends.

Setting the timer

1. Press **MENU**.
2. Select EXTRAS. Press **OK**.
3. Select TIMER. Press **OK**.
4. Select ON. Press **OK**.
5. Press **LEFT** or **RIGHT** to select the hour/minute/second.
6. Press **DOWN** to set the next item.
7. Press **OK** when finished. The timer starts counting.

Turning off the timer

When the timer expires

The handset rings when the timer expires. To turn off the timer,

1. Press **STOP**.



NOTE: If you do not turn off the timer, it will turn off after 1 minute.

Before the timer expires

1. Press **MENU**.
2. Select EXTRAS. Press **OK**.
3. Select TIMER. Press **OK**. TURN IT OFF? is displayed.
4. Press **YES**. The timer is turned off.

Calling Features

Your phone supports a number of call-related features to help you handle and manage your calls more effectively and conveniently.



TIP: Use UP and DOWN to navigate the menus.

AUTO ANSWER

Auto answer enables you to answer an incoming call by simply picking up the handset from the charging cradle. You do not need to press a key to answer the call.

Activating/Deactivating auto answer

1. Press **MENU**.
2. Select SETTINGS. Press **OK**.
3. Select CALL SERVICES. Press **OK**.
4. Select AUTO ANSWER. Press **OK**.
5. Select the new setting.
6. Press **OK**. The new setting is saved.

DO NOT DISTURB

“Do not disturb” turns off all the ringers of your handset. Your handset will not ring when it receives a call.

Activating/Deactivating do not disturb

1. Press **MENU**.
2. Select SETTINGS. Press **OK**.
3. Select CALL SERVICES. Press **OK**.
4. Select DO NOT DISTURB. Press **OK**.
5. Select the new setting.
6. Press **OK**. The new setting is saved.



TIP: Do Not Disturb Shortcut. Press and hold  during standby.

RECALL SELECTION

Recall is a signal that needs to be sent when using some of the calling features such as making or answering a second call. Your phone supports different recall signals. You can make changes depending on the requirements. Your phone shall already be set up for use in your country. For details, consult your service provider.

Selecting recall duration

1. Press **MENU**.
2. Select ADVANCED. Press **OK**.
3. Select RECALL. Press **OK**.
4. Select the new setting.
5. Press **OK**. The new setting is saved.

PAUSE SELECTION

A pause is a break you can enter when making a call. A pause is used for calls such as PABX and operator services. Your phone supports different pause durations. For details, consult your service provider

Selecting pause duration

1. Press **MENU**.
2. Select ADVANCED. Press **OK**.

Calling Features

3. Select PAUSE. Press **OK**.
4. Select the new setting.
5. Press **OK**. The new setting is saved.

PREFIX INSERTION

The prefix insertion feature automatically adds a prefix before a number that you have defined. Your phone checks if the number you have dialed matches with the number you have defined in the menu. If it matches, the prefix you have defined will be added. If it doesn't match, the prefix will not be added.

For example, you set the prefix "604" and the number "555". When you make a call "5551212", "604" will be added before the number, and then "6045551212" will be dialed out.

You can program up to 3 prefix/number combinations.

Activating prefix insertion

1. Press **MENU**.
2. Select ADVANCED. Press **OK**.
3. Select PREFIX. Press **OK**.
4. Enter the system PIN. Press **OK**.
5. Select the prefix you want to set.
6. Press **LEFT** or **RIGHT** to select ON. Press **DOWN**.
7. Enter the prefix (up to 8 digits) you want to insert. Press **DOWN**.
8. Enter the number (up to 8 digits) for checking.



TIP: Leave the number blank if you want the prefix to be inserted to all outgoing calls.

9. Press **OK** when finished. The new setting is saved.

Deactivating prefix insertion

1. Press **MENU**.
2. Select ADVANCED. Press **OK**.
3. Select PREFIX. Press **OK**.
4. Enter the system PIN. Press **OK**.
5. Press **LEFT** or **RIGHT** to select OFF.
6. Press **OK** when finished. The new setting is saved.

PABX PREFIX

If you are connecting your phone to a PABX, you may need to enter an access code (e.g. 0) in order to get an outside line. You may also need to enter a pause in the dialing sequence to allow time for the PABX to pick up an outside line.

The PABX prefix feature on this phone inserts and dials the PABX access code (up to 8 digits) and a pause before each call.

Setting up the PABX prefix

1. Press **MENU**.
2. Select ADVANCED. Press **OK**.
3. Select PABX. Press **OK**.
4. Enter the system PIN 0000. Press **OK**.
5. Press **LEFT** or **RIGHT** to select ON. Press **DOWN**.
6. Enter the PABX access code. Then Press and hold  to enter a pause. P displays on the screen.
7. Press **OK** when finished. The new setting is saved.

Deactivating the PABX prefix

1. Press **MENU**.
2. Select **ADVANCED**. Press **OK**.
3. Select **PABX**. Press **OK**.
4. Enter the system PIN. Press **OK**.
5. Press **LEFT** or **RIGHT** to select **OFF**.
6. Press **OK** when finished. The new setting is saved.

CALL BARRING

The call barring feature allows you to restrict or block selected handset(s) from dialing out certain numbers.



NOTE: The call barring feature does not affect receiving incoming calls, making emergency calls or intercom calls.

Your phone supports 4 call barring options.

Option	What is it?
Off	Call barring is deactivated.
All	All calls are blocked except emergency number(s).
Exempt	All calls are blocked except the numbers defined and emergency number(s).
Bar	Only the defined number is blocked.

Activating call barring

1. Press **MENU**.
2. Select **ADVANCED**. Press **OK**.
3. Select **CALL BARRING**. Press **OK**.
4. Enter the system PIN. Press **OK**.
5. Select the handset you want to block. Press **OK**.
6. Press **LEFT** or **RIGHT** to select the new setting. Press **DOWN**.
7. Enter the number (up to 5 digits) for the **EXEMPT** or **BAR** option only.
8. Press **OK** when finished. The new setting is saved.

Deactivating call barring

1. Press **MENU**.
2. Select **ADVANCED**. Press **OK**.
3. Select **CALL BARRING**. Press **OK**.
4. Enter the system PIN. Press **OK**.
5. Select the handset you want to deactivate. Press **OK**.
6. Press **LEFT** or **RIGHT** to select **OFF**.
7. Press **OK** when finished. The new setting is saved.

Extra Features

Discover and explore the additional features your phone offers! Find out how these features can benefit you and help you make the most from your phone.



TIP: Use **UP** and **DOWN** to navigate the menus.

DIRECT PAGING

Direct paging works like a one-way walkie-talkie phone. It allows you to talk to another handset user by a single press on a key.

Defining a target handset

You can program a handset that you always call. After programming, you can call this handset directly by a single press on a key.

1. Press and hold **DIRECT PAGE**.
2. Select the target handset. Press **OK**.

Making a direct page

You can talk to the other handset user after the connection is established. The other handset user can hear you, but the user cannot talk to you directly. The other handset user can make a direct page and talk to you after ending the current page.

1. Press **DIRECT PAGE**. Start talking after the connection is established.
2. Press  to end the direct page.

CALL CAMPING

When you are trying to make a call and the line is occupied by another handset, you can ask your phone to notify you when the line becomes free.

Activating call camping

1. When you are trying to make a call and the line is busy, wait for a few seconds until "CALL CAMPING?" is displayed.
2. Press **YES** to camp on the line.

When the line is free, your handset rings and displays "CAMPING CALL".

3. Press **OK** to make a call **OR**
Press **NO** to cancel if you do not want to make a call now.

KEYPAD LOCK

You can lock the keypad to prevent accidental presses on the handset while you are carrying it around.

Locking the keypad

1. Press and hold . The keypad is locked, and  is displayed.



Unlocking the keypad

1. Press **UNLOCK**. **UNLOCK?** is displayed.
2. Press **OK** to confirm. The keypad is unlocked.



TIP: Keypad Unlock Shortcut. Press and hold .

MISSING HANDSET(S)

1. Press  on the base unit. All the handsets connected to this base unit ring.
2. Press  on the base unit again to stop paging. All the handsets stop ringing **OR**
Press **STOP** on each handset to stop the paging of each handset.

NEW MESSAGE INDICATION

Your phone notifies you with an envelope  icon when you have received a new missed call, text (SMS) message, voicemail or notification.

Reviewing the indication

1. When you see , press **UP** or **DOWN** during standby to enter the new message screen. The new message screen shows you the type and number of new messages you have received.



For details on retrieving these messages, refer to the respective sections.

The System



TIP: Use UP and DOWN to navigate the menus.

REVIEWING/SELECTING YOUR COUNTRY

The country setting of your phone has been set during the initial set up of your phone. You can review the current country setting on your phone.

1. Press **MENU**.
2. Select SYSTEM. Press **OK**.
3. Select COUNTRY SETTINGS. Press **OK**.
4. Press **OK** when finished.

If you want to make changes to the country setting, you have to first reset your phone (refer to *Resetting to default settings* on page 46). For instruction on selecting country after reset, refer to *Selecting your country* on page 9.

REGISTERING YOUR HANDSET(S) WITH ADDITIONAL BASE

This section shows you how to register your handset to additional base unit(s). If your handset displays NOT REG, refer to *Registering your handset* on page 9.

1. Press **MENU**.
2. Select SYSTEM. Press **OK**.
3. Select REGISTER. Press **OK**.
4. Select the base number you want. Press **OK**. This base number will be assigned to the base unit you are about to register to.
5. Enter the system PIN. Use **DELETE** to make correction.
6. Press **OK** to confirm. Your handset starts searching for the base.
7. Press **PAGE** on the base unit for 4 seconds. The base unit sounds 2 short beeps. The registration process shall be completed within 30 seconds.



NOTE: Each handset can register up to 4 base units. After registering 4 base units, your handset registration memory is full. When you register to an additional base unit, your new registration will replace an old one.

SELECTING A BASE UNIT

You can switch your handset between different base units if your handset has registered to these base units. For your convenience, you can program the handset to automatically connect to the closest base unit. You can also program the handset to only connect to a fixed base unit you have specified.

1. Press **MENU**.
2. Select SYSTEM. Press **OK**.
3. Select SELECT BASE. Press **OK**.
4. Select the base unit you want or select AUTO if you want your handset to automatically connect to the closet base unit.
5. Press **OK**. The new setting is saved.

DELETING A HANDSET

Use one handset to delete (de-register) another handset that shares the same base unit.

1. Press **MENU**.
2. Select SYSTEM. Press **OK**.
3. Select DELETE HANDSET. Press **OK**.
4. Select the handset you want to delete. Press **OK**.

5. Enter the system PIN. Use **DELETE** to make correction.
6. Press **OK**. The handset is deleted.

DEFINING LINE MATRIX

The line matrix feature allows you to assign privileges and restrictions on selected handsets from making and receiving calls.

Your phone supports 5 line matrix options.

Option	What is it?
Line 1 In	Line 1 response on receiving calls.
Line 2 In	Line 2 response on receiving calls.
Line 1 Out	Line 1 privilege on making calls.
Line 2 Out	Line 2 privilege on making calls.
Ring Count	This is the number of rings before a handset will ring and/or can answer a call. This is used for Line 1 In and Line 2 In matrix option.

1. Press **MENU**.
 2. Select SYSTEM. Press **OK**.
 3. Select LINE MATRIX. Press **OK**.
 4. Enter the system PIN. Press **OK** to confirm. Use **DELETE** to make correction.
 5. Select the line matrix option. Press **OK**.
- After selecting the option, refer to the respective sub-sections below to finish the operation.

Assigning line 1 or line 2 In setting

1. Select the handset you want to set. Press **OK**.
2. Select the option setting.

Setting	What is it?
Blocked	The handset will not ring and cannot answer calls until a certain number of rings have completed (defined in the ring count setting below).
Normal	The handset has no restriction on answering calls.
Interception	The handset can answer calls anytime; however, the handset will not ring until a certain number of rings have completed (defined in the ring count setting below).

3. Press **OK** to confirm. The new setting is saved.



NOTE: Caller ID. If line 1 or line 2 is set to BLOCKED or INTERCEPTION, your phone may not be able to receive/display Caller ID depending on your ring count setting.

Assigning line 1 or line 2 Out

Select the handset you want to set. Press **OK**.

4. Select the option setting.

Setting	What is it?
Blocked	The handset can only make emergency calls.
Normal	The handset has no restriction on making calls.

5. Press **OK** to confirm. The new setting is saved.

Assigning ring count setting

1. Select LINE 1 or LINE 2. Press **OK**.

The System

2. Select the number of rings.
3. Press **OK** to confirm. The new setting is saved.

CHANGING THE SYSTEM PIN

The system PIN is used for registering, deleting handsets, and protecting the access rights to some of the other menus. The default system PIN is 0000. You can personalize the PIN for greater security.

1. Press **MENU**.
2. Select SYSTEM. Press **OK**.
3. Select CHANGE PIN. Press **OK**.
4. Enter the system PIN. Press **OK** to confirm. Use **DELETE** to make correction.
5. Enter the new system PIN. Press **OK**.
6. Enter the new system PIN again for verification.
7. Press **OK**. The new setting is saved.



NOTE: Forgotten PIN. Write down your PIN and save it for future use. If you have forgotten the PIN, call your manufacturer for assistance.

RESETTING TO DEFAULT SETTINGS

The default settings are the original factory settings of your phone. You can reset your phone settings to factory default.

1. Press **MENU**.
2. Select SYSTEM. Press **OK**.
3. Select RESET. Press **OK**.
4. Enter the system PIN. Press **OK** to confirm. Use **DELETE** to make correction. CONFIRM? is displayed.
5. Press **YES** to confirm. All settings have reset.



NOTE: After reset, your handset returns to the "Hello" screen if your model supports multiple country settings, and you must configure your country settings before using your phone, refer to *Greeting you with "HELLO"* on page 9.

To find out what settings are being reset, see *Default Settings* on page 46.

Appendix

DEFAULT SETTINGS

These are the factory pre-programmed settings of your phone.

General Setting			
Language	<i>English</i>	Handset Name*	<i>Unchanged</i>
Date Format	<i>DD/MM/YY</i>	Time Format	<i>24 hours</i>
Date	<i>Pre-set Date</i>	Time	<i>00:00</i>
Auto Answer	<i>On</i>	Do Not Disturb	<i>Off</i>
Dial Mode	<i>Tone</i>	LCD Contrast	<i>Medium</i>
Recall Duration	<i>Recall 1</i>	Pause Selection	<i>Pause 1</i>
Prefix	<i>Off</i>	Prefix and numbers	<i>Empty</i>
PABX	<i>Off</i>	PABX Number	<i>Empty</i>
Area Code Removal	<i>Off</i>	Area Code number	<i>Empty</i>
Alarm Clock	<i>Off</i>	Stopwatch	<i>Off</i>
Countdown Timer	<i>Off</i>	Operator Services	<i>Unchanged</i>
Language	<i>English</i>	Handset Name*	<i>Unchanged</i>
Date Format	<i>DD/MM/YY</i>	Time Format	<i>24 hours</i>

Sounds Setting			
Line 1 Ring Melody	<i>Melody 1</i>	Line 1 Ring Volume	<i>Level 3</i>
Line 2 Ring Melody	<i>Melody 2</i>	Line 2 Ring Volume	<i>Level 3</i>
Intercom Ring Melody	<i>Melody 3</i>	Intercom Ring Volume	<i>Level 3</i>
Key Beep	<i>On</i>	Confirmation/Parking Tone	<i>On</i>
Receiver Volume	<i>Medium</i>		

Call Log Setting			
Message Waiting Indicator	<i>Reset</i>	Call Log Options	<i>Unchanged</i>
Missed Call Log	<i>Unchanged</i>	Dialed Call Log	<i>Unchanged</i>
Received Call Log	<i>Unchanged</i>	Notification	<i>Unchanged</i>
Last Call Timer	<i>Reset</i>	Dialed Call Timer	<i>Reset</i>
Received Call Timer	<i>Reset</i>	All Calls Timer	<i>Reset</i>

System Setting			
Line Matrix for LINE 1 IN	<i>Normal</i>	Line Matrix for LINE 2 IN	<i>Normal</i>
Line Matrix for LINE 1 OUT	<i>Normal</i>	Line Matrix for LINE 2 OUT	<i>Normal</i>
Ring Count for Line 1	<i>3</i>	Ring Count for Line 2	<i>3</i>
PIN Code	<i>0000</i>	Base Selection	<i>Auto</i>

* This setting is not restored after reset.

Appendix

TROUBLESHOOTING

Problem	Tip
No dial tone	<ul style="list-style-type: none">• Check all the phone line and power adaptor connections.• The handset may be out of range of the base. Move closer to the base.• The battery capacity may be low. Charge battery.
Signal icon flashing	<ul style="list-style-type: none">• The handset may be out of range. Move closer.• If the handset displays NOT REG, it is un-registered. Register the handset. See page 9.
No parking tone	<ul style="list-style-type: none">• The handset may not be placed properly. Try again.• Charging contacts may be dirty. Clean contacts with a damp cloth.• Turn on the handset tone. See page 35.• Switch on the handset's power. See page 10.
Handset on the charger does not charge	<ul style="list-style-type: none">• The battery may be defective. Purchase new battery from your dealer.• Check that the battery is inserted correctly.• Make sure the handset is placed properly on the charger. The battery icon is animated while charging.
No display	<ul style="list-style-type: none">• Check that the battery is charged.• Check the connections.
Bad audio (crackles, echo, etc.)	<ul style="list-style-type: none">• The handset may be nearly out of range. Move closer.• The phone base may be too close to an electrical appliance. Move the base unit to a different location.• The phone base may be too close to thick concrete walls. Move the base unit to a different location.
Handset does not ring	<ul style="list-style-type: none">• Check that the handset ringer is turned on. See page 35.• Check that Do Not Disturb is turned off. See page 39.• Too many phones may be sharing the same phone line. Disconnect some of the phones.
Caller ID does not display	<ul style="list-style-type: none">• Caller ID service may not be activated. Check with your service provider.• The caller's information may be withheld or is unavailable.
Cannot make/answer a 2 nd call	<ul style="list-style-type: none">• 2nd call service may not be activated. Check with your service provider.• Check that the recall selection is correct. See page 38.

NOTES FOR OPERATION IN NEW ZEALAND

The grant of a Telepermit for any item of terminal equipment indicates only that Telecom has accepted that the item complies with the minimum conditions for connection to its network. It indicates no endorsement of the product by Telecom, nor does it provide any sort of warranty. Above all, it provides no assurance that any item will work correctly in all respects with another item of Telepermitted equipment of a different make or model, nor does it imply that any product is compatible with all of Telecom's network services. This device may be subject to ringing or bell tinkle when certain other devices are connected to the same line. If this occurs, the problem should not be referred to the Telecom Faults service.

This equipment shall not be set to make automatic calls to the Telecom "111" Emergency Service. This equipment may not provide for the effective hand-over of a call to another device connected to the same line.

REN (RN for New Zealand)

The REN (Ringer Equivalence Number) or (RN) is of significance only if you wish to connect more than 1 telephone to your telephone line. A standard telephone line has a maximum REN capacity of 3 (RN of 5). It is possible to connect 3(5) devices with a REN of 1 (RN of 1) with no degradation to the product's performance. Exceeding this limit may cause the volume of the ringer in any phone to decrease or not ring at all.

Caller ID

Customers using non Telecom toll services should not use the dial back feature for local calls as this will incur a charge only the 7 digit number should be dialled. Some of the CID services listed may not be available in New Zealand.

This telephone is not designed for making emergency telephone calls when the power fails. Make alternative arrangements for access to emergency services.

WARRANTY

- (a) **Warranty.** Oricom warrants that the product is free from defects in materials and workmanship for a period of 12 months effective from the date of purchase. This warranty in no way affects your statutory warranty under the Trade Practices Act 1974 or any other similar legislation. **It is important that you read the Warranty Card** as it contains full and additional details of the warranty, limitation of warranty and conditions for receiving the warranty services during the warranty period. The Warranty Card is located in the package. If you cannot locate the Warranty Card, please contact our Customer Support Service on 1300 889 785.
- (b) **Exclusion and limitation of liability.** Oricom will not be in breach of a warranty or condition expressly stated in this User Guide or the Warranty Card or implied by the Trade Practices Act and excludes any liability arising under any statutory or common law for damages or any other remedy if the damage occurs as a result of:
- (i) failure by you to follow the instructions in the User Guide for the installation and proper functioning of the product;
 - (ii) negligence on your part or misuse by you of the product;
 - (iii) any un-controlled external cause to the phone not functioning including but not limited to electricity failure, lighting, over voltage;
 - (iv) non adherence by you to the warnings in the User Guide and the User Guide generally; and
 - (v) modification to the product or services carried out to the product by anyone other than Oricom or on Oricom's behalf.

Oricom will not be liable for consequential losses including loss of profits arising from a cause of action in contract, tort or any other statutory or common law (except where a statute or any law prohibits this exclusion). The warranty does not extend to damage caused by misuse, negligence, excessive voltage, faults on the telephone line or lightning. This warranty in no way affects your statutory rights. Full details of the warranty are contained in the enclosed warranty card.

Appendix

CUSTOMER SUPPORT

If you feel this product is not working correctly please consult the user guide and ensure that you are using the product in accordance with the instructions. Remove all extra telephone equipment and connect only this telephone directly to the telephone socket. If the fault is still present, connect another telephone (if available) to the telephone socket. The results will show you whether the fault lies with this unit or with the telephone line.

If the product is working correctly the fault is on the telephone line. Please contact your network operator for assistance.

To order spare parts additional handsets, replacement batteries and in case of any technical issues you may have with product please consult our website for further information or send us an email for a prompt response to your enquiry.

In the unlikely event of a fault developing, please contact us for assistance. If the product is then found to be faulty you will be asked to return it directly to us with a copy of the purchase receipt.

Australia
Oricom International Pty Ltd
Locked bag 658
South Windsor, NSW 2756

Customer support

Email: support@oricom.com.au
Web: www.oricom.com.au
Fax: (02) 4574 8898
Ph: 1300 889 785

New Zealand
Atlas Gentech (NZ) Limited
Private Bag 14927,
Panmure, Auckland

Customer support

Email: support@atlasgentech.co.nz
Web: www.atlasgentech.co.nz
Fax: (09) 574 2722
Ph: 0900 50 025 (Toll Call)

Free Manuals Download Website

<http://myh66.com>

<http://usermanuals.us>

<http://www.somanuals.com>

<http://www.4manuals.cc>

<http://www.manual-lib.com>

<http://www.404manual.com>

<http://www.luxmanual.com>

<http://aubethermostatmanual.com>

Golf course search by state

<http://golfingnear.com>

Email search by domain

<http://emailbydomain.com>

Auto manuals search

<http://auto.somanuals.com>

TV manuals search

<http://tv.somanuals.com>