



# ORION<sup>®</sup>

HIGH PERFORMANCE CAR AUDIO



*Coaxial Speaker*

MODEL

**XTR402**

**XTR462**

**XTR522**

**XTR572**

**XTR602**

**XTR652**

**XTR693**

**OWNER'S MANUAL**

# TABLE OF CONTENTS

English .....	1
Français .....	9
Español.....	13
Deutsch .....	17
Italiano.....	21
Português .....	25
Introduction.....	1
Practice Safe Sound™.....	1
What's in the Box .....	2
Tools of the Trade .....	2
Installation.....	2
Finding Speaker Mounting Locations .....	3
Door Mounting.....	3
Rear Deck Mounting.....	3
Step by Step Installation.....	4
Specifications.....	6
Features.....	6
Warranty .....	.back cover

## INTRODUCTION

Thank you for your purchase of Orion's XTR Coaxial Speakers. These speakers offer renowned Orion excellence in every high performance speaker system. Designed for OEM applications, the XTR coaxial speakers will fit standard 4", 5.25", 6", 6.5" round and 4"x6", 5" x 7", 6" x 9" oval mounting locations.

We at Orion strive to give you all the latest up to date information about this product. What we can't give you in this manual is personal installation or technical experience. If you have questions concerning the use or application of this product, please refer to the nearest Authorized Orion Dealer for assistance or call the Orion technical support hot-line at -800-876-0800 as we are always finding new ways to improve our product, the features and specifications are subject to change without notice.

## PRACTICE SAFE SOUND™

Continuous exposure to sound pressure levels over 100dB may cause permanent hearing loss. High powered automotive sound systems can generate sound pressure levels in excess of 130dB. When playing your system at high levels, please use hearing protection and prevent long term exposure.

Model Number: \_\_\_\_\_

Serial Number: \_\_\_\_\_

Date of Purchase: \_\_\_\_\_

## WHAT'S IN THE BOX

Included in this box are all the necessary mounting hardware and cables for your basic installation. Listed below is a detailed list of the components included in this system package.

Quantity	Description
1	Owner's Manual
1	Mounting template
2	XTR Coaxial Speakers
2	Grilles (except for 4", 4"x6", 5"x7")
	Mounting Screws

## TOOLS OF THE TRADE

Listed are the majority of the tools required to perform the installation. Having the proper tools will make the installation much easier. Some of these tools are required.

- marking pen
- wire crimpers
- volt-ohm meter (opt.)
- 1/8" drill bit
- assorted tin snips
- Phillips screwdriver
- 41/8" (105mm) hole saw (4" Coaxial installation)
- 43/4" (120mm) hole saw (5.25" Coaxial installation)
- 51/8" (130mm) hole saw (6" & 6.5" Coaxial installation)
- needle nose pliers
- electric drill
- wire strippers
- wire cutters
- hole saw arbor

## INSTALLATION

The performance of the XTR coaxial speakers is directly proportional to the quality of installation. Care taken during the installation process will be rewarded with years of satisfying performance. If you are unsure about your installation capabilities, please refer to your local Authorized Orion Dealer for technical assistance. Orion dealers are trained professionals dedicated to obtaining the maximum performance out of your Orion system. If you decide to install this speaker system yourself, please read the entire installation section before starting your installation.

# FINDING SPEAKER MOUNTING LOCATIONS

Choosing the correct speaker locations will have the greatest effect on the sound quality of the system. Different considerations are needed when choosing the locations that best suit your needs. The locations must be large enough for the speakers to fit. Care is needed to ensure that the location you have chosen will not affect any of the mechanical or electrical operations of the vehicle.

Determining the best location for the speakers will depend on your cosmetic needs and your vehicle's interior. If minimal intrusion in your vehicle is desired, factory speaker locations may be the ticket for you. Placing the speaker in the factory location can often give very desirable results.

## DOOR MOUNTING

When checking for possible speaker locations in the doors, check the operation of the window and all of the doors assemblies. There is also a stabilizer stop bar in between the door and the door jamb. This bar prevents the door from opening too far. Pay particular attention to this so you do not damage the speaker when you close the door.

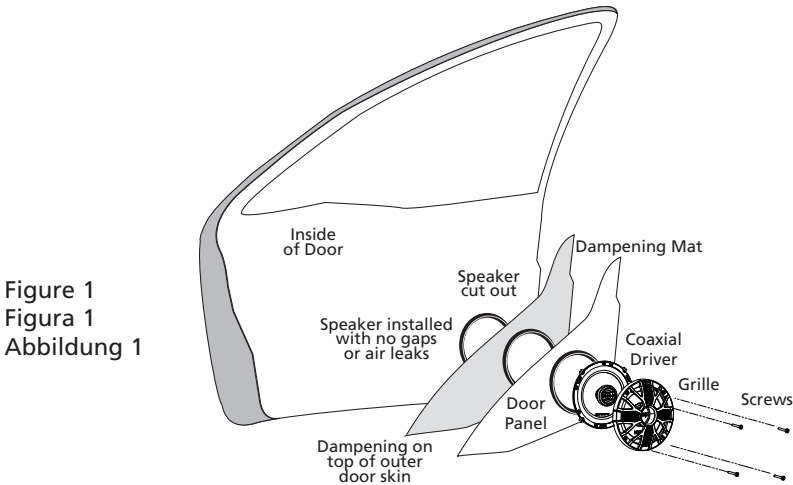
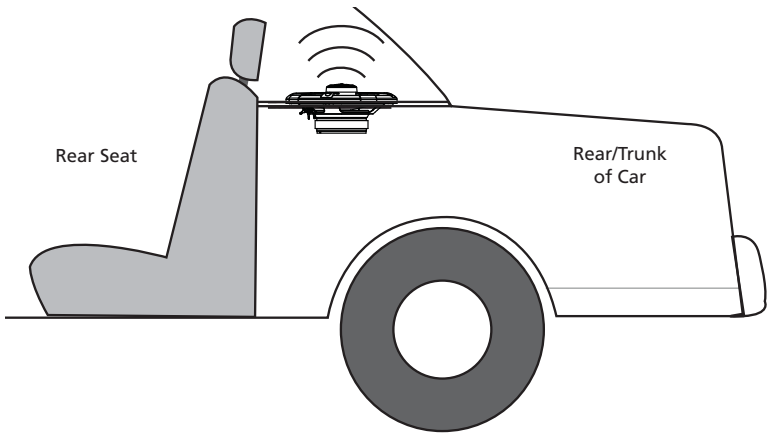

Figure 1  
Figura 1  
Abbildung 1

## REAR DECK MOUNTING

In rear deck installations, check the operation of the trunk suspension springs or tension bars. These tension bars move in the opening and closing of the trunk. You cannot be too cautious during this part of the installation. In addition, do not locate the speakers too close to the back of the rear deck. Mounting the far screws will only be possible with the removal of the rear window.

Figure 2  
Figura 2  
Abbildung 2



## STEP BY STEP INSTALLATION

Step 1: Determine where the speaker will be mounted. Make sure there is a flat area large enough for the speaker to fit properly. An uneven mounting surface can damage the driver.

Step 2: Check to make sure the space you have chosen for the speaker will not interfere with the operation of the vehicle.

Step 3: Using a template, mark the speaker hole with a pen.

Step 4: Cut the hole for the speaker. When using factory locations, this step can be passed. A hole can be cut either with a pair of metal tin snips or a hole saw corresponding to the size of the speaker listed below.

- 4 1/8" (105mm) hole saw (4" Coaxial installation)
- 4 3/4" (120mm) hole saw (5.25" Coaxial installation)
- 5 1/8" (130mm) hole saw (6" & 6.5" Coaxial installation)

Step 5: Run the speaker wire to the speakers. Make sure to keep wires away from sharp metal or other edges. When passing through metal, use a protective grommet.

Step 6: Using the template, mark the mounting holes with a pen.

Step 7: Pre-drill mounting holes using a 1/8" drill bit.

Step 8: Pull the wire through the speaker opening and connect to the speaker.

Step 9: Mount the speaker and grill in the hole using the same screws. Insert the screws through the grill and the mounting holes in the basket.

**WARNING: Window mechanisms and electrical wires may be hidden from sight. CHECK FOR CLEARING BEFORE YOU DRILL!**

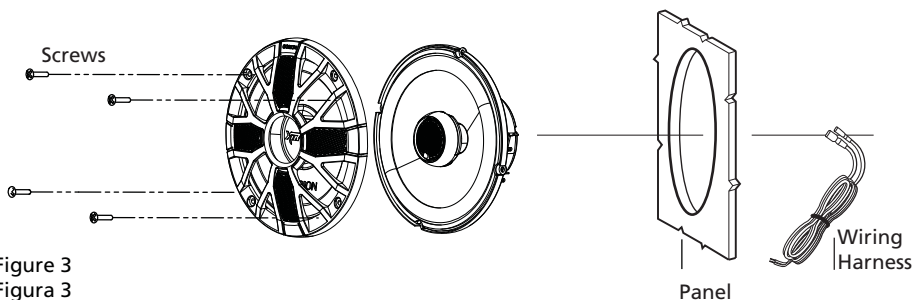

Figure 3  
Figura 3  
Abbildung 3

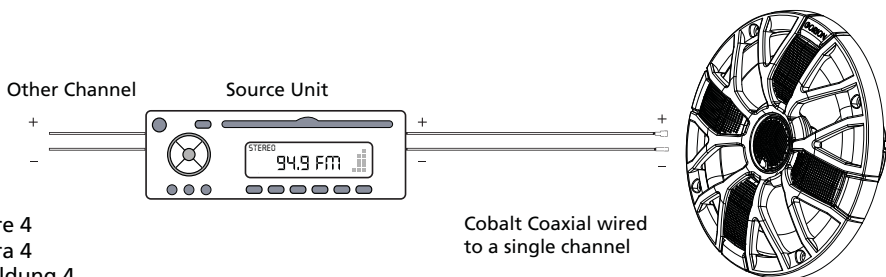

Figure 4  
Figura 4  
Abbildung 4

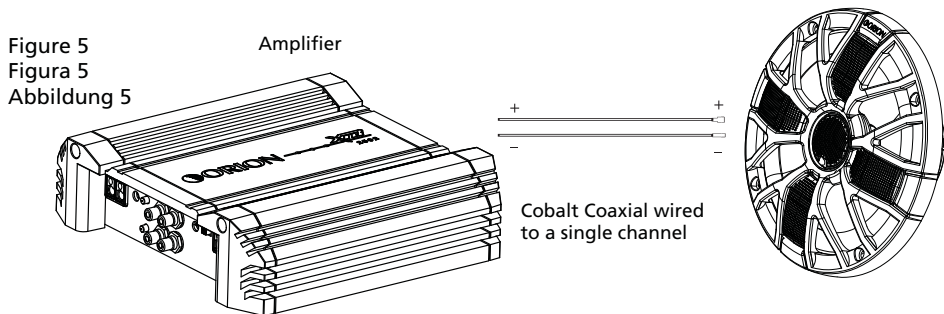

Figure 5  
Figura 5  
Abbildung 5

- \* The XTR speakers can be powered by a head unit or an amplifier.
- \* Les haut-parleurs XTR peuvent être alimentés par un récepteur ou un amplificateur.
- \* Los altavoces XTR se pueden alimentar con una unidad principal o un amplificador.
- \* Die XTR-Lautsprecher können von einem Autoradio oder einem Verstärker betrieben werden.
- \* Gli altoparlanti XTR possono essere alimentati da una Head Unit o da un amplificatore.
- \* Os alto-falantes de XTRo podem ser acionados por uma unidade principal ou um amplificador.

# SPECIFICATIONS

MODEL	XTR402	XTR462	XTR522	XTR572	XTR602	XTR652	XTR693
Nominal Impedance (ohms)	4	4	4	4	4	4	4
Power Continuous/ Maximum (watts)	50/80	50/80	50/100	50/100	50/100	60/120	100/180
Frequency Response (Hz)	120 to 22k	90 to 22k	85 to 22k	80 to 22k	85 to 22k	85 to 22k	55 to 22k
Sensitivity (dB)	86	86	86	89	86	86	89
Mounting Depth (inches)	1.89	1.89	2.28	2.17	1.75	2.01	3.23
Mounting Diameter (inches)	4.06	3.66 x 6.11	4.72	4.96 x 7.17	5.20	5.04	5.79 x 8.43

# FEATURES

Cone	moisture and UV resistant paper cone
Surround	Butyl Rubber
Voice Coil	2 layer copper wire on a Kapton former
Tweeter	silk dome - Ferrofluid
Spider	Nomex
Stamped steel baskets with Euro mounting configurations	
Two way systems have custom crossover with 6 dB high pass, 6 dB low pass and tweeter protection (6dB high pass only on XTR402)	
Swivel tweeter (on select models only)	

**NOTE:** All specifications are subject to change without notice.

Figure 6  
 Figura 6  
 Abbildung 6

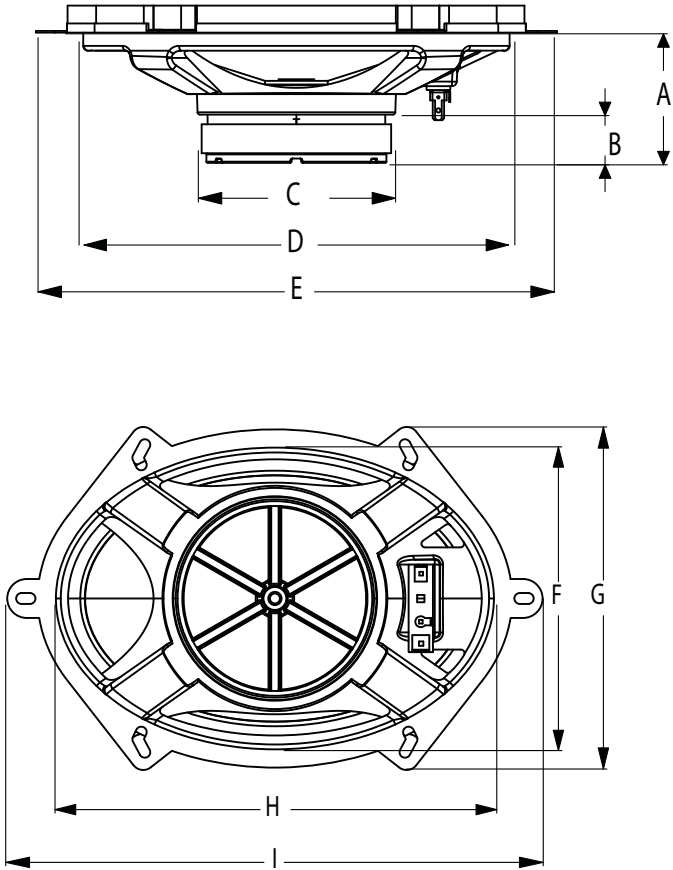

	XTR402	XTR462	XTR522	XTR572	XTR602	XTR652	XTR693
Dimensions inches/mm, Dimensions pouces/mm, Dimensiones plg./mm, Abmessungen Zoll/mm, Dimensioni pollici/millimetri, Dimensões polegadas/mm							
A	1.89/48	1.89/48	2.28/58	2.17/55	1.75/44.5	2.01/51	3.23/82
B	0.79/20	0.75/19	0.91/23	0.79/20	0.91/23	0.83/21	1.18/30
C	2.76/70	2.56/65	2.76/70	3.11/79	2.76/70	3.15/80	3.94/100
D	4.06/102		4.72/120		5.20/132	5.04/128	
E	5.04/128		5.79/147		6.36/161.5	6.30/160	
F		3.66/93		4.96/126			5.79/147
G		4.10/104		5.52/140			6.46/164
H		6.11/155		7.17/182			8.43/214
I		6.11/155		8.67/220			9.25/235





# FRANÇAIS

## OÙ MONTER LES HAUT-PARLEURS

Le choix du bon emplacement des haut-parleurs aura un effet majeur sur la qualité du son du système. Plusieurs choses doivent être prises en considération pour faire le meilleur choix. Les emplacements doivent être assez grands pour accueillir les haut-parleurs. Faites attention que l'emplacement choisi n'affecte en aucune façon le fonctionnement mécanique et électrique du véhicule.

Le meilleur emplacement pour les haut-parleurs dépend de vos goûts et de l'aménagement intérieur du véhicule. Si vous voulez une installation aussi discrète que possible, les emplacements prévus par le fabricant sont sans doute le meilleur choix. Cela donnera souvent d'excellents résultats.

## MONTAGE SUR UNE PORTIÈRE

Quand vous recherchez une location possible pour installer vos haut-parleurs dans les portières, vérifiez le fonctionnement de la fenêtre et de tous les mécanismes. Vérifiez aussi la barre stabilisatrice entre la portière et son montant. Elle empêche la portière de s'ouvrir trop grand. Faites très attention pour ne pas endommager le haut-parleur quand vous fermez la porte (Figure 1).

## MONTAGE DANS LE COFFRE

Pour une installation dans le coffre, vérifiez le fonctionnement des ressorts de suspension ou barres de tension du coffre. Ces barres se déplacent durant l'ouverture et la fermeture du coffre. On n'est jamais trop prudent durant cette partie de l'installation. De plus, ne placez pas les haut-parleurs trop près de l'arrière du coffre. L'installation des vis les plus écartées n'est possible que si on retire la vitre arrière (Figure 2).

# INSTALLATION PAS À PAS

Étape 1: Décidez où fixer les haut-parleurs et assurez-vous qu'il y ait une surface plane suffisante pour bien les fixer. Une surface de montage inégale peut endommager le moteur.

Étape 2: Assurez-vous que l'emplacement choisi pour les haut-parleurs n'interfère pas avec le fonctionnement du véhicule.

Étape 3: Au moyen d'un gabarit et d'un crayon, marquez l'emplacement du trou du haut-parleur.

Étape 4: Découpez le trou pour le haut-parleur. Si vous utilisez les emplacements prévus par le fabricant, cette étape peut être sautée. Utilisez soit une paire de cisailles à tôles ou une scie-cloche de la taille correspondant à celle du haut-parleur ci-dessous.

- Scie-cloche 4-1/8" (105 mm) (4")
- Scie-cloche 4-3/4" (120 mm) (5-1/4")
- Scie-cloche 5-1/8" (130 mm) (6 & 6-1/2")

Étape 5: Amenez les câbles à leurs haut-parleurs. Assurez-vous de les garder loin de tout bord métallique ou autre aiguisé. Pour passer à travers le métal, utilisez une rondelle isolante.

Étape 6: Utilisez le gabarit et un crayon pour marquer les trous de montage.

Étape 7: Pré-percez les trous de montage avec une mèche 1/8".

Étape 8: Faites passer le câble par l'ouverture du haut-parleur et raccordez au haut-parleur.

Étape 9: Montez le haut-parleur et sa grille dans le trou avec les mêmes vis. Insérez les vis à travers la grille et les trous de montage du panier.

**NOTE:** Diagramme de référence aux page 5 (figure 3,4,5)

**ATTENTION:** Les mécanismes et fils électriques des fenêtres peuvent être masqués. VÉRIFIEZ L'ESPACE DISPONIBLE AVANT DE PERCER!

# SPÉCIFICATIONS

MODÈLE	XTR402	XTR462	XTR522	XTR572	XTR602	XTR652	XTR693
Impédance nominale (ohms)	4	4	4	4	4	4	4
Puissance continue/ maximum (watts)	50/80	50/80	50/100	50/100	50/100	60/120	100/180
Réponse de fréquence (Hz)	120 - 22k	90 - 22k	85 - 22k	80 - 22k	85 - 22k	85 - 22k	55 - 22k
Sensitivité (dB)	86	86	86	89	86	86	89
Profondeur de montage (pouces)	1.89	1.89	2.28	2.17	1.75	2.01	3.23
Diamètre de montage (pouces)	4.06	3.66 x 6.11	4.72	4.96 x 7.17	5.20	5.04	5.79 x 8.43

# CARACTÉRISTIQUES

Cône	Papier résistant à l'humidité et aux ultraviolets
Boîtier	Caoutchouc butyle
Bobine acoustique	Fil de cuivre 2 couches sur manchon Kapton
Haut-parleur d'aigus	Dôme de soie – Ferrofluid
Anneau de centrage	Nomex
Paniers en acier matricé avec configuration de montage européen	
Systèmes bidirectionnels avec répartiteur personnalisé: passe-haut 6 dB, passe-bas 6 dB et protection du haut-parleur d'aigus (filtre passe-haut 6 dB sur XTR402 uniquement)	
Haut-parleur d'aigus orientable (sur certains modèles uniquement)	

**NOTE:** Toutes spécifications sujettes à changement sans préavis.



# ESPAÑOL

## UBICACIONES DE MONTAJE DE LOS ALTAVOCES

Escoger la ubicación correcta de los altavoces tendrá el mayor efecto en la calidad del sonido del sistema. Es necesario que usted tenga en cuenta varias consideraciones cuando escoja el lugar que mejor se adapte a sus necesidades. Los lugares escogidos deben ser lo suficientemente grandes como para que quepan los altavoces. Es necesario que en la ubicación escogida no se afecte ninguna operación mecánica o eléctrica del vehículo.

Determinar la mejor ubicación de los altavoces depende de sus necesidades cosméticas y del interior del vehículo. Si desea interferir lo menos posible con el vehículo, las ubicaciones de altavoz de fábrica son ideales. Colocar el altavoz en la ubicación de fábrica puede a menudo dar muy buenos resultados.

## MONTAJE EN LA PUERTA

Cuando esté buscando posibles ubicaciones de altavoz en las puertas, verifique el funcionamiento de las ventanas y de todos los mecanismos de las puertas. También hay una barra de tope estabilizadora entre la puerta y la jamba de la puerta. Esta barra evita que la puerta se abra demasiado. Preste especial atención a esto para no dañar el altavoz al cerrar la puerta (figura 1).

## MONTAJE EN LA REPISA TRASERA

En las instalaciones en repisa trasera, verifique el funcionamiento de los resortes de suspensión o barras de tensión de la tapa del maletero. Estas barras de tensión se mueven cuando el maletero se abre o se cierra. Ser precavido nunca está de más durante esta parte de la instalación. Además, no ubique los altavoces demasiado cerca del fondo de la repisa trasera. Montar los tornillos del fondo será posible solamente quitando la ventana trasera (figura 2).

# INSTALACIÓN PASO A PASO

Paso 1: Determine el lugar en que va a montar el altavoz. Debe haber una superficie plana suficientemente grande como para que el altavoz encaje correctamente. Las superficies de montaje irregulares pueden dañar el excitador.

Paso 2: Verifique que, en el espacio que ha escogido, el altavoz no interfiera con el funcionamiento del vehículo.

Paso 3: Con la plantilla y un lápiz, marque los agujeros de montaje del altavoz.

Paso 4: Haga el agujero para el altavoz. Cuando instale los altavoces en ubicaciones de fábrica, este paso se puede omitir. El agujero se puede hacer con unas tijeras para cortar metal o una sierra circular que corresponda al tamaño de altavoz que se indica abajo.

- Sierra circular de 4 1/8 plg. (105 mm) (altavoz de 4 plg.)
- Sierra circular de 4 3/4 plg. (120 mm) (altavoz de 5 1/4 plg.)
- Sierra circular de 5 1/8 plg. (130 mm) (altavoz de 6 & 6 1/2 plg.)

Paso 5: Encamine el cable de altavoz hasta los altavoces. Mantenga los cables de altavoz lejos de los bordes afilados de metal u otro material. Cuando pase los cables a través de metal, ponga en el agujero una arandela de goma protectora.

Paso 6: Marque los agujeros de montaje con la plantilla y un lápiz.

Paso 7: Haga de antemano los agujeros de montaje con una broca perforadora de 1/8 de plg.

Paso 8: Jale el cable a través de la abertura del altavoz y conéctelo al altavoz.

Paso 9: Monte el altavoz y la rejilla en el agujero con los mismos tornillos. Inserte los tornillos a través de la rejilla y los agujeros de montaje de la canasta del altavoz.

**Consulte el diagrama de la página 5 (figura 3,4,5)**

**ADVERTENCIA:** Puede haber cables eléctricos y mecanismos de ventana ocultos. VERIFIQUE QUE HAYA ESPACIO ANTES DE TALADAR.

# ESPECIFICACIONES

MODELO	XTR402	XTR462	XTR522	XTR572	XTR602	XTR652	XTR693
Impedancia nominal (ohms)	4	4	4	4	4	4	4
Potencia continua/máxima (W)	50/80	50/80	50/100	50/100	50/100	60/120	100/180
Respuesta de frecuencias (Hz)	120 - 22k	90 - 22k	85 - 22k	80 - 22k	85 - 22k	85 - 22k	55 - 22k
Sensibilidad (dB)	86	86	86	89	86	86	89
Profundidad de montaje (plg.)	1.89	1.89	2.28	2.17	1.75	2.01	3.23
Diámetro de montaje (plg.)	4.06	3.66 x 6.11	4.72	4.96 x 7.17	5.20	5.04	5.79 x 8.43

# CARACTERÍSTICAS

Cono	cono de papel resistente a la humedad y los rayos ultravioleta
Envolvente	Goma de butilo
Bobina de voz	Alambre de cobre de 2 capas en un formador Kapton
Tweeter	Domo de seda - Ferrofluido
Araña	Nomex
Canastas de acero troquelado con configuraciones de montaje Euro	
Los sistemas de dos canales tienen crossover a la medida con pasaaltas de 6 dB, pasabajas de 6 dB y protección de tweeter (filtro pasa altas de 6dB sólo en XTR402)	
Tweeter oscilante (sólo en modelos selectos)	

**NOTA:** Todas las especificaciones están sujetas a cambios sin aviso previo.





# DEUTSCH

## SO PLATZIEREN SIE DIE LAUTSPRECHER

Die Wahl der korrekten Lautsprecherposition hat große Auswirkungen auf die Soundqualität des Systems. Bei der Wahl der Lautsprecherposition, die Ihren Ansprüchen am besten entspricht, sind mehrere Faktoren zu beachten. Es muss an der Stelle genügend Platz für den Lautsprecher vorhanden sein. Sie müssen sicherstellen, dass die gewählte Stelle die mechanischen oder elektrischen Funktionen des Fahrzeugs nicht beeinträchtigt.

Die Wahl der geeigneten Einbaustelle hängt sowohl von ästhetischen Faktoren als auch vom Innenraum Ihres Fahrzeugs ab. Wenn Sie das Fahrzeug nur minimal verändern wollen, sind die werksseitigen Einbaustellen am besten. Der Einbau an diesen Stellen kann oft zu sehr guten Ergebnissen führen.

## TÜREINBAU

Wenn Sie mögliche Lautsprechereinbaustellen in den Türen suchen, müssen Sie die Funktionen der Fenster und aller Baugruppen der Türen beachten. Zwischen der Tür und der Türschwelle befindet sich eine Stabilisator-Anschlagleiste. Diese Leiste verhindert, dass die Tür sich zu weit öffnet. Achten Sie darauf, damit Sie beim Schließen der Tür den Lautsprecher nicht beschädigen (abbildung 1).

## EINBAU IM KOFFERRAUM

Beim Einbau im Kofferraum ist auf die Funktionsfähigkeit der Kofferraumfedern oder Zugstäbe zu achten. Diese Zugstäbe bewegen sich beim Öffnen und Schließen des Kofferraums. Seien Sie bei diesem Teil der Installation besonders vorsichtig und platzieren Sie die Lautsprecher auch nicht zu nahe an der Kofferraumhinterkante. Der Einbau der hinteren Schrauben ist erst nach Ausbau des Rückfensters möglich (abbildung 2).

# SCHRITTWEISE EINBAUANLEITUNG

1. Schritt: Legen Sie die Einbaustelle für die Lautsprecher fest. Vergewissern Sie sich, dass es sich um eine ebene Stelle handelt, die groß genug für den fachgerechten Einbau ist. Eine unebene Oberfläche kann den Treiber beschädigen.
2. Schritt: Stellen Sie sicher, dass die gewählte Stelle den Betrieb des Fahrzeugs auf keine Weise behindert.
3. Schritt: Verwenden Sie eine Schablone und markieren Sie das Lautsprecherloch mit einem Stift.
4. Schritt: Schneiden Sie das Loch für den Lautsprecher aus. Bei Verwendung der werksseitigen Einbaustellen kann dieser Schritt übersprungen werden. Man kann das Loch entweder mit einer Blechschere oder einer Lochsäge ausschneiden, je nach Größe des unten aufgelisteten Lautsprechers.
  - 4,125 Zoll (105 mm) Lochsäge (4 Zoll)
  - 4,75 Zoll (120 mm) Lochsäge (5,25 Zoll)
  - 5,125 Zoll (130 mm) Lochsäge (6 & 6,5 Zoll)
5. Schritt: Verlegen Sie die Lautsprecherkabel zu den Lautsprechern. Dabei müssen Sie die Kabel von scharfen Metallkanten oder anderen Kanten entfernt halten. Bei der Verlegung durch Metall ist eine Schutztülle zu verwenden.
6. Schritt: Verwenden Sie die Schablone und markieren Sie die Einbaulöcher mit einem Stift.
7. Schritt: Bohren Sie die Befestigungslöcher mit einem 1/8-Zoll-Bohrer vor.
8. Schritt: Ziehen Sie das Kabel durch die Lautsprecheröffnung und schließen Sie es an den Lautsprecher an.
9. Schritt: Installieren Sie den Lautsprecher und den Lautsprechergrill mit denselben Schrauben in der Einbauöffnung. Führen Sie die Schrauben durch den Grill in die Befestigungslöcher am Korb ein.

**Siehe Diagramm auf Seite 5 (Abbildung 3, 4, 5).**

**WARNUNG:** Eventuell sind Fenstermechanismen und Stromkabel nicht sichtbar. PRÜFEN SIE VOR DEM BOHREN, DAMIT SIE NICHTS ANBOHREN!

# DATEN

MODELL	XTR402	XTR462	XTR522	XTR572	XTR602	XTR652	XTR693
Nennimpedanz (Ohm)	4	4	4	4	4	4	4
Dauerleistung/ Spitzenleistung (Watt)	50/80	50/80	50/100	50/100	50/100	60/120	100/180
Frequenzgang (Hz)	120 - 22k	90 - 22k	85 - 22k	80 - 22k	85 - 22k	85 - 22k	55 - 22k
Empfindlichkeit (dB)	86	86	86	89	86	86	89
Einbautiefe (Zoll)	1.89	1.89	2.28	2.17	1.75	2.01	3.23
Einbaudurchmesser (Zoll)	4.06	3.66 x 6.11	4.72	4.96 x 7.17	5.20	5.04	5.79 x 8.43

# EIGENSCHAFTEN

Membran	Feuchtigkeits- und UV-beständige Papiermembran
Sicke	Butylkautschuk
Schwingspule	Zweischichtig, kupferbeschichtet, auf Kapton-Träger
Hochtöner	Seiden-Kalottenhochtöner - Ferrofluid
Zentriermembran	Nomex
Körbe aus Stahlblech mit Euro-Befestigungskonfiguration	
Zweiwegsysteme haben spezielle Crossover-Einheiten mit 6 dB Hochpass, 6 dB Tiefpass und Hochtönerschutz. (6 dB Hochpass nur beim XTR402)	
Schwenkbarer Hochtöner (nur bei bestimmten Modellen)	

**HINWEIS:** Alle Daten können ohne vorherige Ankündigung geändert werden.



# ITALIANO

## INDIVIDUAZIONE DELLA POSIZIONE DI MONTAGGIO DEGLI ALTOPARLANTI

La scelta della posizione degli altoparlanti ha la massima influenza sulla qualità del suono dell'impianto. Nella scelta delle posizioni di montaggio che soddisfano meglio le proprie esigenze, occorre considerare diversi fattori. Le posizioni devono offrire uno spazio sufficiente per l'altoparlante. Accertarsi con cura che la posizione scelta non interferisca con il funzionamento dei componenti meccanici o elettrici del veicolo.

La scelta della posizione migliore per gli altoparlanti dipende dalle esigenze estetiche del proprietario e dalla configurazione dell'interno del veicolo. Se si desidera che il montaggio interferisca il meno possibile con il veicolo, la cosa migliore è avvalersi delle sedi di montaggio predisposte in fabbrica. Collocando l'altoparlante nella sede predisposta in fabbrica spesso si ottengono risultati estremamente desiderabili.

## MONTAGGIO SULLE PORTIERE

Quando si valutano le possibili posizioni di montaggio sulle portiere, controllare il funzionamento dei finestrini e di tutti i componenti delle portiere stesse. Tra portiera e relativo montante c'è anche una barra stabilizzatrice di arresto. La barra evita un'apertura eccessiva della portiera. Prestare particolare attenzione a questa barra in modo da non danneggiare l'altoparlante quando si chiude la portiera (**figura 1**).

## MONTAGGIO NEL PIANO PORTAOGGETTI POSTERIORE

In caso di montaggio nel piano portaoggetti posteriore, controllare il funzionamento delle molle di sospensione o dei tiranti dello sportello del vano bagagli. Questi tiranti si muovono quando si apre e chiude lo sportello. Prestare la massima attenzione durante questa fase del montaggio. Inoltre, non collocare gli altoparlanti troppo vicini alla parte posteriore del piano portaoggetti. In questo caso, sarà possibile montare le viti esterne solo smontando il lunotto posteriore (**figura 2**).

# INSTALLAZIONE PROCEDIMENTO DETTAGLIATO

Fase 1: stabilire dove montare l'altoparlante. Accertarsi che ci sia una superficie piana abbastanza grande per montare correttamente l'altoparlante. Una superficie di montaggio irregolare può danneggiare il driver.

Fase 2: accertarsi che lo spazio scelto per l'altoparlante non interferisca con il funzionamento del veicolo.

Fase 3: usando una dima, segnare con una penna il contorno del foro per l'altoparlante.

Fase 4: praticare il foro per l'altoparlante. Quando si inserisce l'altoparlante nelle sedi predisposte in fabbrica, è possibile tralasciare queste operazioni. Eseguire il foro con un paio di forbici da lattoniere o con una sega a tazza delle misure dell'altoparlante indicate di seguito.

- sega a tazza da 4 1/8" (105 mm) (per un altoparlante da 4")
- sega a tazza da 4 3/4" (120 mm) (per un altoparlante da 5 1/4")
- sega a tazza da 5 1/8" (130 mm) (per un altoparlante da 6" & 6 1/2")

Fase 5: passare il filo fino all'altoparlante. Accertarsi di tenere i fili lontani da bordi od oggetti di metallo taglienti. Quando si passano i fili in un foro in un oggetto metallico, usare un anello di protezione.

Fase 6: usando la dima, segnare con una penna i punti dei fori di fissaggio.

Fase 7: eseguire i fori di fissaggio usando una punta per trapano da 3,2 mm (1/8").

Fase 8: tirare il filo attraverso l'apertura nell'altoparlante e collegarlo all'altoparlante stesso.

Fase 9: montare l'altoparlante e la griglia nel foro usando le stesse viti. Inserire le viti nella griglia e nei fori di montaggio nel telaio.

**Vedere lo schema a pagina 5 (Figura 3,4,5).**

**ATTENZIONE:** i meccanismi e i fili elettrici dei finestrini possono essere nascosti. **CONTROLLARE PRIMA DI ESEGUIRE I FORI!**

## DATI TECNICI

MODELLO	XTR402	XTR462	XTR522	XTR572	XTR602	XTR652	XTR693
Impedenza nominale (ohm)	4	4	4	4	4	4	4
Assorbimento continuo/ Massimo (watt)	50/80	50/80	50/100	50/100	50/100	60/120	100/180
Risposta in frequenza (Hz)	120 - 22k	90 - 22k	85 - 22k	80 - 22k	85 - 22k	85 - 22k	55 - 22k
Sensibilità (dB)	86	86	86	89	86	86	89
Profondità di montaggio (pollici)	1.89	1.89	2.28	2.17	1.75	2.01	3.23
Diametro di montaggio (pollici)	4.06	3.66 x 6.11	4.72	4.96 x 7.17	5.20	5.04	5.79 x 8.43

## CARATTERISTICHE

Cono	Cono in carta resistente all'umidità e ai raggi ultravioletti
Surround	Gomma butilica
Bobina mobile	doppio strato di filo di rame su un supporto in Kapton
Tweeter	Cupola in seta - Ferrofluido
Centratore	Nomex
Telai in acciaio stampato con configurazioni di montaggio europee	
Gli impianti a due vie hanno un crossover su misura con filtro passa alto da 6 dB, filtro passa basso da 6 dB e protezione del tweeter (filtro passa alto da 6 dB solo sul XTR402)	
Tweeter girevole (solo su certi modelli)	

**NOTA:** tutti i dati tecnici possono essere modificati senza preavviso.





# PORTUGUÊS

## DETERMINAÇÃO DOS LOCAIS PARA INSTALAÇÃO DOS ALTOS-FALANTES

A seleção dos locais corretos para instalação dos alto-falantes é o fator que mais influenciará a qualidade do som produzido pelo sistema. É necessário considerar vários aspectos ao escolher os locais mais adequados às suas necessidades. Os locais de instalação devem ser grandes o suficiente para acomodar os alto-falantes e é necessário cuidado para assegurar que os locais escolhidos não afetem nenhuma das funções mecânicas ou elétricas do veículo.

A determinação dos melhores locais para a instalação dos alto-falantes dependerá de suas necessidades estéticas e do interior do veículo. Para minimizar a intrusão dos alto-falantes na aparência interna do veículo, as posições predefinidas pela fábrica podem ser a solução mais adequada. Colocar os alto-falantes nas posições definidas pela fábrica pode muitas vezes produzir resultados muito satisfatórios.

## INSTALAÇÃO NAS PORTAS

Ao verificar os possíveis locais para instalação dos alto-falantes nas portas, estude como funcionam os vidros e todos os componentes das portas. Existe também uma barra de limitação estabilizadora entre a porta e o batente. Ela evita que a porta se abra demasiadamente. Preste atenção especial a essa característica para não danificar o alto-falante ao fechar a porta (**figura 1**).

## INSTALAÇÃO NO PAINEL TRASEIRO

Nas instalações no painel traseiro, verifique como as molas de suspensão ou barras de tensão da tampa do porta-malas funcionam. Essas barras de tensão se movimentam quando o porta-malas é aberto e fechado. Muito cuidado é pouco durante essa parte da instalação. Além disso, não posicione os alto-falantes muito próximos da parte de trás do painel traseiro, pois só será possível apertar os parafusos mais afastados se o vidro traseiro for removido (**figura 2**).

# INSTALAÇÃO PASSO A PASSO

Etapa 1: Determine onde o alto-falante será instalado. Certifique-se de que seja uma área plana e grande o suficiente para encaixar bem o alto-falante. Uma superfície de instalação desigual pode danificar o alto-falante.

Etapa 2: Certifique-se de que o espaço selecionado para a instalação do alto-falante não interferirá com o funcionamento do veículo.

Etapa 3: Usando um modelo, marque com uma caneta o orifício onde o alto-falante será instalado.

Etapa 4: Corte o orifício para a instalação do alto-falante. Esta etapa pode ser ignorada para instalação nos locais designados pela fábrica. Um orifício pode ser cortado com uma tesoura para metal fina ou uma serra copo correspondente ao tamanho do alto-falante descrito abaixo.

- Serra copo de 105 mm (4 1/8") para instalação do alto-falante de 102 mm (4")
- Serra copo de 120 mm (4 3/4") para instalação do alto-falante de 133 mm (5 1/4")
- Serra copo de 130 mm (5 1/8") para instalação do alto-falante de 165 mm (6" & 6 1/2")

Etapa 5: Passe o cabo para caixa acústica até os alto-falantes. Mantenha os cabos afastados de superfícies de metal ou outras bordas afiadas. Use um olhal de proteção ao passar o cabo através de metal.

Etapa 6: Usando o modelo, marque com uma caneta os orifícios de instalação.

Etapa 7: Perfure os orifícios de instalação usando uma broca de 3,2 mm (1/8").

Etapa 8: Puxe o cabo através da abertura do alto-falante e conecte-o ao alto-falante.

Etapa 9: Instale o alto-falante e a grade no orifício usando os mesmos parafusos. Insira os parafusos através da grade e os orifícios de instalação na guarnição do cone.

**Consulte o diagrama na página 5 (Figura 3,4,5).**

**ATENÇÃO:** Podem existir mecanismos e fios elétricos de operação do vidro da janela ocultos. CONFIRME SE HÁ ESPAÇO SUFICIENTE ANTES DE PERFURAR!

# ESPECIFICAÇÕES

MODELO	XTR402	XTR462	XTR522	XTR572	XTR602	XTR652	XTR693
Impedância nominal (ohms)	4	4	4	4	4	4	4
Potência contínua/máxima (watts)	50/80	50/80	50/100	50/100	50/100	60/120	100/180
Resposta de frequência (Hz)	120 - 22k	90 - 22k	85 - 22k	80 - 22k	85 - 22k	85 - 22k	55 - 22k
Sensibilidade (dB)	86	86	86	89	86	86	89
Profundidade de instalação (polegadas)	1.89	1.89	2.28	2.17	1.75	2.01	3.23
Diâmetro de instalação (polegadas)	4.06	3.66 x 6.11	4.72	4.96 x 7.17	5.20	5.04	5.79 x 8.43

## CARACTERÍSTICAS

Cone	Cone de papel resistente à umidade e à radiação ultravioleta
Surround	Borracha butílica
Bobina móvel	Fio de cobre de duas camadas em um copo Kapton
Tweeter	Cúpula de seda - Ferrofluido
Aranha	Nomex
Carcaças de aço estampado com configurações de instalação europeias	
Sistemas bidirecionais com crossover personalizado com passa-alta de 6 dB, passa-baixa de 6 dB e proteção de tweeter (filtro passa-altas de 6dB apenas no XTR402)	
Tweeter pivotante (apenas em modelos específicos)	

**NOTA:** Todas as especificações estão sujeitas a alterações sem aviso prévio.

# WARRANTY

## LIMITED ONE-YEAR CONSUMER WARRANTY/\*LIMITED TWO-YEAR CONSUMER WARRANTY FOR AUTHORIZED DIRECTED DEALER PURCHASE & INSTALLATION

Directed Electronics (herein "Directed") promises to the original purchaser of the subwoofer or amplifier, as applicable (herein "Unit" or "Product"), to repair or replace with a new or refurbished Unit (at Directed's sole and absolute discretion) should the Unit prove to be defective in workmanship or material under normal use, for a period of \*two-years from the date of purchase from the authorized Directed dealer PROVIDED the Unit was purchased and installed by an authorized Directed dealer. During this \*two-year period, there will be no charge for the repair or replacement PROVIDED the Unit is returned to Directed (DO NOT RETURN THE ENTIRE ENCLOSURE. PLEASE RETURN THE WARRANTIED UNIT ONLY), shipping prepaid, along with the required proof of installation, the bill of sale or other dated proof of purchase, and the consumer's contact information. If the Unit is installed by anyone other than an authorized Directed dealer, the warranty period will be one-year from the date of purchase. This warranty is non-transferable and does not apply to any Unit that has been modified or used in a manner contrary to its intended purpose, and does not cover damage to the Unit caused by installation or removal of the Unit. During this one-year period, there will be no charge for the repair or replacement PROVIDED the Unit is returned to Directed, shipping pre-paid, along with the bill of sale or other dated proof of purchase and the consumer's contact information. This warranty is void if the product has been damaged by accident or unreasonable use, neglect, improper service or other causes not arising out of defects in materials or construction. This warranty does not cover the elimination of externally generated static or noise, or the correction of antenna problems or weak reception, damage to speakers, accessories, electrical systems, cosmetic damage or damage due to negligence, misuse, failure to follow operating instructions, accidental spills or customer applied cleaners, damage due to environmental causes such as floods, airborne fallout, chemicals, salt, hail, lightning or extreme temperatures, damage due to accidents, road hazards, fire, theft, loss or vandalism, damage due to improper connection to equipment of another manufacturer, modification of existing equipment, or Product which has been opened or tampered for any reason. Units which are found to be damaged by abuse resulting in thermally damaged voice coils are not covered by this warranty but may be replaced at the absolute and sole discretion of Directed. Unit must be returned to Directed (DO NOT RETURN THE ENTIRE ENCLOSURE. THE UNIT ENCLOSURE IS COVERED BY A SEPARATE 90-DAY LIMITED CONSUMER WARRANTY. PLEASE ONLY RETURN THE WARRANTIED UNIT UNLESS A WARRANTY CLAIM IS BEING MADE FOR THE ENCLOSURE.), postage pre-paid, with bill of sale or other dated proof of purchase bearing the following information: consumer's name, telephone number, and address, authorized dealer's name and address, and product description. Unit must be returned to the following address: ATTN: WARRANTY DEPARTMENT, Directed Electronics , 1 Viper Way, Vista, CA 92081. Note: This warranty does not cover labor costs for the removal and/or reinstallation of the Unit. IN ORDER FOR THE TWO-YEAR WARRANTY TO BE VALID, YOUR UNIT MUST BE SHIPPED WITH PROOF OF INSTALLATION BY AN AUTHORIZED DIRECTED DEALER. ALL UNITS RECEIVED BY DIRECTED FOR WARRANTY REPAIR WITHOUT PROOF OF DIRECTED DEALER INSTALLATION AND PURCHASE WILL BE COVERED BY THE LIMITED 1 YEAR WARRANTY.

BY PURCHASING THIS PRODUCT, ALL WARRANTIES INCLUDING BUT NOT LIMITED TO EXPRESS WARRANTY, IMPLIED WARRANTY, WARRANTY OF MERCHANTABILITY, FITNESS FOR PARTICULAR PURPOSE, AND WARRANTY OF NON-INFRINGEMENT OF INTELLECTUAL PROPERTY ARE EXPRESSLY EXCLUDED TO THE MAXIMUM EXTENT ALLOWED BY LAW, AND DIRECTED NEITHER ASSUMES NOR AUTHORIZES ANY PERSON TO ASSUME FOR IT ANY LIABILITY IN CONNECTION WITH THE SALE OF THE PRODUCT. DIRECTED HAS ABSOLUTELY NO LIABILITY FOR ANY AND ALL ACTS OF THIRD PARTIES INCLUDING ITS AUTHORIZED DEALERS OR INSTALLERS. IN NO EVENT WILL DIRECTED BE LIABLE FOR ANY INCIDENTAL, SPECIAL OR CONSEQUENTIAL DAMAGES (INCLUDING LOSS OF PROFITS). BY PURCHASING THIS PRODUCT, THE CONSUMER AGREES AND CONSENTS THAT ALL DISPUTES BETWEEN THE CONSUMER AND DIRECTED SHALL BE RESOLVED IN ACCORDANCE WITH CALIFORNIA LAWS IN SAN DIEGO COUNTY, CALIFORNIA. This warranty is only valid for sale of Product within the United States of America. Product sold outside of the United States of America is sold "AS-IS," and shall have NO WARRANTY, express or implied. Some states do not allow limitation on how long an implied warranty lasts. In such states, the limitation or exclusions of this Limited Warranty may not apply. Some states do not allow the exclusion or limitation of incidental or consequential damages. In such states, the exclusion or limitation of this Limited Warranty may not apply to you. This Limited Warranty gives you specific legal rights, and you may have other rights which vary from state to state. 920-0033 04-07

For more information on Orion products please visit [www.orioncaraudio.com](http://www.orioncaraudio.com)



ISO 9001 registered company

Directed Electronics is an ISO 9001 registered company.

**Directed Electronics is committed to delivering world class quality products and services that excite and delight our customers.**

*distributed by*  
**Directed**  
ELECTRONICS  
Vista, CA 92081  
**WWW.DIRECTED.COM**

## Free Manuals Download Website

<http://myh66.com>

<http://usermanuals.us>

<http://www.somanuals.com>

<http://www.4manuals.cc>

<http://www.manual-lib.com>

<http://www.404manual.com>

<http://www.luxmanual.com>

<http://aubethermostatmanual.com>

Golf course search by state

<http://golfingnear.com>

Email search by domain

<http://emailbydomain.com>

Auto manuals search

<http://auto.somanuals.com>

TV manuals search

<http://tv.somanuals.com>