

# HCCA

COMPETITION

OWNERS MANUAL



©1999 Orion Industries, Incorporated  
9235 S. McKemy Street , Tempe, Arizona 85284  
Phone: 480.705.5600 Fax: 480.705.7339

One of the ADST family of companies.

Part # 319-0730 REV B, 11/99





## ORION Mission Statement-

As a leader in the audio industry, ORION is dedicated to taking sound to the next generation by supplying the market with innovative, quality products incorporating state-of-the-art designs with world-class manufacturing. We pledge to support our products with superior customer service and marketing excellence.

## DECLARATION OF CONFORMITY

**Manufacturer's name:** Orion Industries  
**Manufacturer's address:** 9235 S. McKemy  
Tempe, AZ 85284

*declares, that the product:*

**Product name:** HCCA 5s Component Speaker System  
HCCA 6s Component Speaker System

*conforms to the following standards:*

EN 50 081-1/1992  
EN 50 082-1/3.1995

**European contact:**

Axel Perwitz  
audiomax GmbH  
Heilbronn Germany

# TABLE OF CONTENTS

- Introduction.....3
- About this manual.....3
- Features of your 3-series loudspeaker.....4
- Warnings and tips.....5
- System planning.....5
  - Amplifier requirements.....6
- Mounting locations.....6
- Controls and connections.....6
  - Tweeter level control.....6
  - Midrange contour.....7
  - Connections to the amplifier.....7
- Speaker wiring.....7
  - Speaker wire selection.....7
  - Polarity and phasing.....7
- Termination.....8
- Speaker mounting.....8
  - Woofer installation.....8
  - Woofer mounting.....8
- Tweeter installation.....10
  - Surface mount.....10
  - Surface mount cup mounting.....10
  - Flush mount.....10
  - Blind installation.....11
  - Tweeter mounting.....11
- Crossover installation.....12
  - Connecting the system.....12
  - Connections to crossover network and radio or amplifier.....13
  - Bi-amplified connections to the crossover network.....13
  - Bi-wired connections to the crossover network.....14
- Troubleshooting.....15
- Jack pinouts.....16
- Specifications.....16
- Warranty information.....17
- CE declaration of conformity.....19

## INTRODUCTION

Thank you for purchasing the Orion HCCA component set. These components were designed to live up to the standard set by the legendary CONCEPT 98.1 separates: complete high fidelity with the Orion attitude. The tunable crossover uses only the highest quality components normally found in high end home audio equipment. Hand made in the USA, the HCCA separates represent the pinnacle of high performance car audio.

## ABOUT THIS MANUAL

This manual is designed to instruct you on the use of your new HCCA components. It will enable you to get the most from your new speakers. But it cannot help you if you do not read it. Read it, learn it, and keep it handy for future reference. If you still need help, call the pros at your local authorized Orion dealer. Additionally, you can call Orion technical at (480) 705-5600.

## FEATURES OF YOUR HCCA COMPONENTS

**Molded woofer basket** - The back bone of any good woofer is its basket. It provides the proper alignment and support structure for the magnet while the very thin braces guarantee a minimum of early reflections off the basket that would be ordinarily transmitted as sonic colorations through the cone.

**Tweeter level control** - A three position control adjusts the volume of the tweeter with respect to the midrange.

**Tweeter contour control** - A three position switch that adjusts the tweeter's lower frequency response curve to compensate for off axis listening.

**Bass contour control** - A three position switch that adjusts the woofer's higher frequency response curve to compensate for off axis listening.

**Multi-mount tweeter** - All of the tweeter mounting options (surface, flush, or angled flush) are supplied with the HCCA systems to mount the high quality ferrofluid cooled neodymium tweeter.

**Bi-amplifiable / Bi-wireable** - The passive crossover supplied with this system is bi-amplifiable or bi-wireable; typically only available in high quality audiophile home loudspeakers, and uses only the finest quality electronic components.

**Solid state tweeter protection** - Advanced protection circuitry provides protection for the tweeter against overpowering or amplifier clipping.

**Optical tweeter protection indicators** - Indicates the tweeter protection circuit is enabled.

**Vented voice coil** - Magnet structure cooling vent enhances power handling capabilities of the woofer.

**Extended center pole** - Woofer magnet geometry provides a symmetrical magnetic pattern to reduce THD.

**Ultimate performance passive crossover** - The passive crossover included with the HCCA separates is derived from the acclaimed CONCEPT 98.1 system. High quality audiophile components and tunable to meet the acoustical requirements of any vehicle.

## WARRANTY INFORMATION

There are two things you must do to ensure trouble free service in the event you need warranty repairs.

- 1 - **Keep your original sales receipt in a safe place.** A copy of the receipt will be required to obtain warranty service.
- 2 - Be sure your retail dealer has written the date, the model number, and the serial number (if applicable) of the Product on the receipt.

To give yourself an extra measure of protection, make a separate record of the information about your purchase and keep it in a safe place. In the event you misplace the sales receipt, your dealer may be able to give you a copy.

Take a moment now to read the terms of your warranty. Check to be sure your sales receipt is dated and has the Product model number and serial number (if applicable) on it. Then put it away in a safe place.

### Orion Limited Warranty

Orion warrants to the original consumer purchaser of the Orion Products described in this manual, that the Product will be free from defects in materials and workmanship for a period of one (1) year after the date of purchase. If the product is installed by an authorized Orion retail dealer, the warranty is extended to three (3) years, Orion's sole obligation under this warranty shall be to provide, without charge, parts and labor necessary to remedy the defects, if any, that appear during the warranty period.

This warranty is the sole and exclusive express warranty given with respect to the Product. All other express warranties are hereby excluded. Neither Orion nor the authorized dealer who sells the Product is responsible for indirect, incidental, or consequential damages. Some states do not allow the exclusion or limitation of incidental or consequential damages, so the above limitation or exclusion may not apply to you. This warranty gives you specific legal rights and you may also have other rights which vary from state to state.

**IMPORTANT** - Keep your original sales receipt. Be sure the retail dealer has written on it the date, model number, and serial number (if applicable) of the Product. This information is required for warranty service.

### This warranty is limited to:

- Products purchased from authorized Orion retail dealers in the United States. Orion will supply a list of authorized dealers on request.

### In order to obtain warranty service you must:

- Return the Product, freight prepaid, to the Orion dealer from which it was purchased. If necessary you may call Orion's Customer Service Department for the names and addresses of authorized Orion dealers in your area.
- Provide proof of purchase in the form of a copy of your original sales receipt. The date, model number, and serial number (if applicable) of the Product must be written on the sales receipt.

### This warranty does not cover:

- Damage that is the result of misuse, abuse, accident (including but not limited to damage by water), faulty hookup, defective or maladjusted associated equipment, or the use of the Product with equipment for which it was not intended.
- Cosmetic defects that appear more than thirty (30) days after the date of purchase. Cosmetic damage caused by improper handling is also excluded.
- Products that are used for commercial purposes.
- The cost of removing or reinstalling the Product.
- Damage that occurs while the Product is being shipped to whoever will service it. See the information above regarding shipping procedures.

### This warranty is void if:

- The Product identification or serial number label is removed or defaced in any way.
- The Product is serviced or repaired by any one other than Orion or an authorized Orion dealer or service agency.

## JACK PIN-OUTS

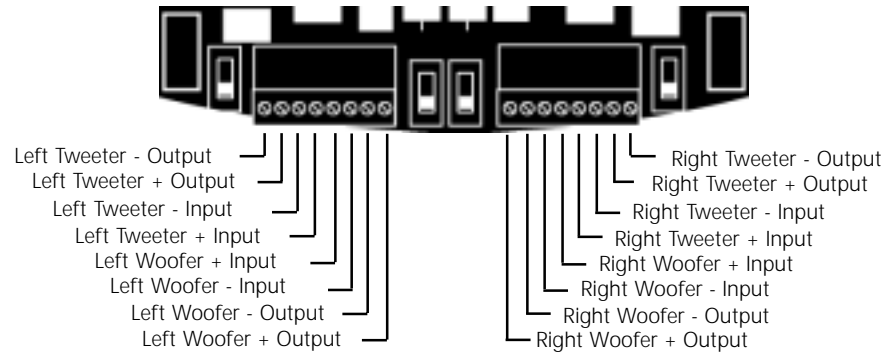

### HCCA 5s

### HCCA 6s

Frequency response +/-3dB:	48Hz to 22kHz	40Hz to 22kHz
Sensitivity 2.83 volt RMS pink noise measured at 1 meter:	90dB	91dB
Impedance, nominal:	2 Ohms	2 Ohms
Recommended amplifier power watts RMS:	15 to 100	15 to 150
Dimensions – woofer/midrange transducer		
Mounting depth (woofer):	2 3/8" / 60mm	2 7/16" / 63mm
Overall height:	2 11/16" / 69mm	2 15/16" / 79mm
Overall maximum diameter:	6" / 152mm	6 1/2" / 165mm
Maximum height above panel without grille:	1/2" / 13mm	5/8" / 16mm
Maximum height above panel with grille:	3/4" / 20mm	15/16" / 24mm
Maximum grille diameter:	6 1/2" / 166mm	7 1/8" / 181mm
Cutout size:	4 5/8" / 118mm	4 15/16" / 125mm
Dimensions – tweeter transducer		
Standard mount height:	1 1/4" / 32mm	1 1/4" / 32mm
Flush mount cutout diameter:	1 7/8" / 48mm	1 7/8" / 48mm
Flush mount depth:	1" / 26mm	1" / 26mm
Dimensions – crossover network		
Length/width/height:	5 3/16" x 3 1/2" x 1 5/8"	132mm x 89mm x 42mm
Thiele-Small specifications		
Free air resonance (F <sub>s</sub> ):	57.2Hz	57.1Hz
Electrical damping (Q <sub>es</sub> ):	.34	.47
Mechanical damping (Q <sub>ms</sub> ):	4.87	6.00
Total damping (Q <sub>t</sub> ):	.32	.44

ORION is always looking for ways to improve its products. Therefore, the specifications are subject to change



Orion tweeters are constructed in concert with the Ferrosound program and use Ferrofluid to provide increased power handling, decreased distortion, minimum electrical impedance change, higher linearity, and smoother frequency response.

## WARNINGS AND TIPS

Study your automobile thoroughly before you drill or cut any holes. Take extra care when working near gas tanks, gas lines, brake or hydraulic lines and electrical wiring.

Wear eye and ear protection when using power tools.

Keep the woofers and tweeters away from metal filings and shavings. Once foreign objects are stuck to the magnets or tweeter dome, it will be virtually impossible to remove them. Keep the tweeters in their protective bags until final mounting to prevent any possibility of metal dust or chips from passing through the grille and accumulating on the dome.

Exercise caution when working with the HCCA's with the grille removed. A slip of the hand with a screwdriver or other tool can result in irreparable damage to the cone or dome. Do not touch the cone or dome.

Do not install the components where they will be subject to excessive heat, moisture or dust; or where they will be kicked or repeatedly bumped or brushed.

Make absolutely sure that the woofer is connected to the lowpass output and the tweeter is connected to the highpass output of the crossover network. If these connections are reversed, low-frequency signals will be fed to the tweeter without fuse protection. In this case, the tweeter may be damaged. Such damage is not covered by the warranty.

When removing or installing the grille on the HCCA's mids, be careful not to brush the woofer's rubber surround or the tweeter's dome with the edge of the grille. Cutting or tearing the surround or dome will destroy the unit.

Never run wires outside or beneath the vehicle where they can be snagged by road hazards or the moving parts of the vehicle. Use existing wire channels, sills, panels and molding strips inside the automobile to hide the wiring for neat appearance and safety.

Make sure your radio/cassette/cd player and or other equipment is turned off while connecting the HCCA's speaker terminals. Turn on the various components and slowly advance the volume control **only** after checking and double checking all connections

**Note:** If sound is weak or distorted, immediately turn down the volume and see the section entitled Troubleshooting.

## SYSTEM PLANNING

Planning your system is the best way to get the most out of your high performance Orion gear. By planning your installation carefully you can avoid situations where the performance or reliability of your system is compromised. The pros at your authorized Orion dealer have been trained to maximize the potential of your Orion system.

# AMPLIFIER REQUIREMENTS

## A note on power handling

The HCCA component system requires a minimum of 20 Watts per channel to achieve reasonable listening volumes in a moving automobile without clipping the amplifier. Orion recommends 150 Watts per channel as a maximum so as not to exceed the thermal or mechanical limitations of the speaker system. Any amplifier between 20 watts and 100 watts per channel may be used. If you choose to use an amplifier with more power than 100 Watts be very careful, you can damage the speaker system if played too loud. The HCCA components produce reasonable volume levels in the automotive environment using moderate amplifier power. However, the use of a low powered amplifier to try and attain very high volume levels can lead to overdriving the amplifier. This will generate high distortion levels which can easily damage loudspeakers, even when the amplifier's rated power is far below the maximum rated power of the loudspeaker. Underpowering a driver is every bit as damaging as overpowering it.

As a rule, do not turn the volume up above the point where you hear distortion on musical peaks from either an overdriven amplifier or mechanical noise from an overstressed speaker. For the best performance and reliability, select an amplifier with slightly more than the maximum power you are likely to need to generate the desired volume levels. This margin of reserve power will ensure that the amplifier will not attempt to deliver more than its design allows.

**Warning:** Practice safe sound! Excessive sound pressure level can permanently damage your hearing. The maximum volume levels attainable with high performance Orion speakers, combined with high-power amplification, may exceed safe levels for extended listening. When listening at high volume levels always use hearing protection or turn it down!

# MOUNTING LOCATIONS

There are many possible choices of mounting locations. The automobile factory locations will usually dictate the woofer mounting position. Because of its small size and multiple mounting options, the tweeter can go virtually anywhere. Orion uses an unusually low crossover frequency for the tweeter which means you are not restricted to mounting the tweeter close to the midrange. The tweeter can be mounted as far as 24" from the midrange without causing adverse effects on the sound quality.

Orion cannot recommend specific locations for the tweeter for each car, but we can give some general tips. Try to keep the tweeters as far to the sides of the car as practical, avoid placing them above ear level unless the woofers are also above ear level. Place the tweeters in similar locations on both sides. Try a few locations by just placing the tweeter or taping it in a location and listening to ensure the desired stereo image and high frequency dispersion are achieved before committing to a location by drilling holes in the automobile.

# CONTROLS AND CONNECTIONS

## Tweeter level control

The three position switch in the crossover box labeled "TWEETER LEVEL" adjusts the relative volume of the tweeter with respect to the midrange. The 0dB position is referenced as equal output from the midrange and tweeter. The -3dB and -6dB positions offer -3dB and -6dB less output from the tweeter respectively. Tweeter level can be adjusted independently for right and left channels to compensate for different listening tastes and mounting locations.

# TROUBLESHOOTING

Symptom	Probable cause	Remedy
No output	Source or amplifier not turned on	Check source or amplifier and fix as needed
	Audio input not connected or no output from source	Check RCA connections and signal integrity, fix or replace as needed
	Protection circuit activated	turn down volume. Protection will self reset
	Speaker wires not connected	Check speaker wires and fix or replace as needed
	Speaker damaged	Check system with known working speaker and fix or replace as needed
Audio cycles on and off	Thermal protection engaged	check that amplifier has adequate ventilation check speaker impedance load
	Loose or poor audio input	Check RCA, power and speaker connections and repair or replace as needed
	Distorted output	Preamp volume set too high, exceeding maximum capability of amplifier.
Distorted output	Impedance load to amplifier too low	Check speaker impedance load, if below 1 ohm rewire the speakers to achieve a higher impedance
	Shorted speaker wires	Check speaker wire connections and repair or replace as needed
	Speaker not connected properly	Check speaker wiring and repair or replace as needed. refer to the speaker wiring section of this manual for detailed instructions
	Speaker damaged	Check system with known working speaker and fix or replace as needed
Poor bass response	Speakers wired with wrong polarity causing cancellation at low frequencies	Check speaker polarity and fix as needed
Lack of stereo separation	Speakers wired with wrong polarity, stereo / bridge switch set to bridge position	Check speaker polarity and fix as needed set switch to stereo position
	Speaker connected across wrong output terminals	Check that the speaker wires are not connected to the bridged terminals and fix as needed
	Source set to mono	Check source and adjust controls as needed

If you want to consult the factory, write or call our customer service department:

Orion Industries  
 9235 S. McKemy Street  
 Tempe, AZ 85284  
 Phone: (480)705-5600  
 Fax: (480)705-7339

## Bi-wire connections to the crossover network

When using a standard two channel amplifier, the HCCA components can be bi-wired. In this case there are two runs of wire from each of the positive and negative outputs of the amplifier for both the left and right channels. The left negative amplifier output is connected to the tweeter IN- and the woofer IN- of the left side of the crossover. The left positive amplifier output is connected to both the tweeter IN+ and the woofer IN- also on the left side of the crossover. This is repeated for the right side.

**Important note:** You must cut the red and black wire jumpers on each side of the crossover that connect the low and high frequency sections of the crossover. Failure to do so could cause damage to the amplifiers or the crossover.

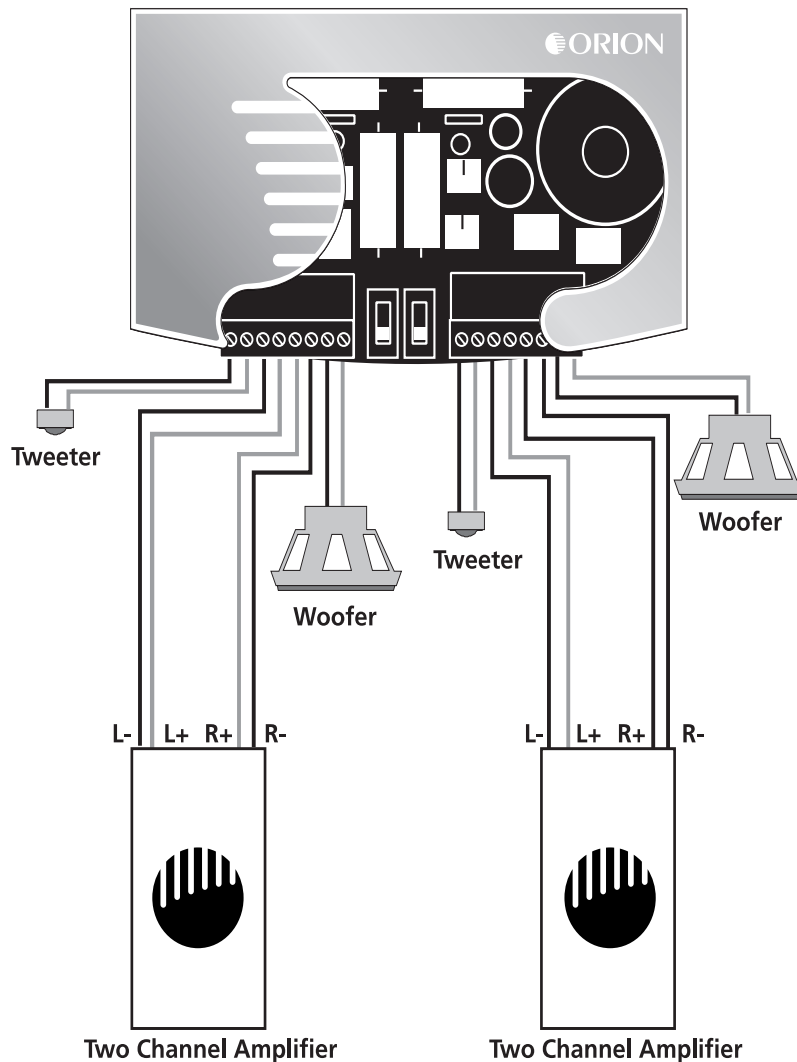

## Tweeter contour

The three position switch labeled "TWEETER CONTOUR" adjusts the lower end of the tweeter's frequency response. One position may sound better than the other, depending on where the tweeter is positioned with respect to close by objects and with respect to the midrange. After installing the system, experiment with both positions and listen carefully to the system.

## Bass contour

The three position switch labeled "BASS CONTOUR" adjusts the upper midrange frequency response. As with the tweeter contour, it is designed to compensate for off axis response and vehicle limitations. It can be adjusted based on your installation scenario and listening tastes. Your ears are the best tools for adjusting the HCCA crossover.

## Connections to the amplifier

The HCCA crossover is supplied with two screw type connectors. Strip the wire from the amplifier about 1/4" from the end and insert into the connector input + and - positions and tighten the set screws. Strip the wire from the woofer and insert into the + and - positions for the crossover woofer output. Follow the same procedure for the connection to the tweeter. The HCCA passive crossover has two sets of input terminals, this allows the system to be bi-wired or bi-amplified.

To bi-amplify the system you will need two stereo amplifiers (or 4 amplifier channels) one for the tweeters and one for the woofers.

If you choose to bi-wire the system, connect the high-pass terminals to the amplifier and connect the low-pass terminals to the same amplifier with another set of speaker wires.

Be sure to connect the positive crossover terminals to the positive speaker terminals and positive amplifier terminals. Also ensure that the negative crossover terminals connect to the negative amplifier and speaker terminals.

Once all of the wires are attached to the connector and the crossover is mounted, the connector can be plugged into its mating receptacle on the crossover.

## SPEAKER WIRING

### Speaker wire selection

Use insulated two-conductor stranded wire to connect the HCCA crossover to the speakers and amplifier. The size of the wire can have an audible effect on the performance of the system. Standard 18 gauge "zip cord" will work, but can result in lower output or unpredictable frequency response. For wire runs of 50 feet or less, we recommend 16 gauge or larger wire. The crossover connector will accept up to 12 gauge wire.

### Polarity and phasing

The polarity - the positive / negative orientation of the connections - for every speaker and amplifier connection must be consistent so all the speakers will be in phase. When the polarity of one connection is reversed, bass output is reduced and stereo imaging is degraded. All wire is marked so you can identify the two conductors. There may be ribs or a stripe on the insulation of one conductor. Identify the positive and negative conductors and be consistent with every speaker and amplifier connection.

## Termination

The woofer uses .187 spade lugs for electrical connections. Use standard .187 or .205 female quick disconnects to attach wires to the woofer.

The tweeter is terminated with bare wire. Use insulated butt connectors, bullet connectors, or quick disconnects to extend the tweeter wires to the crossover location. Alternatively you may solder all connections and insulate them with high quality heatshrink tubing.

# SPEAKER MOUNTING

## Woofer installation

The HCCA woofer will fit into standard factory mounting locations using the existing mounting holes in the automobile. The woofer uses .187 spade type terminals for electrical connections. To connect the woofer, use .187 or .205 female quick disconnects of a size appropriate for the wire gauge you chose. You may also solder wire directly to the terminals. If you choose to solder the wires, be careful not to use excessive heat so you do not melt the plastic around the terminal, which is not covered by the warranty

Remove the trim panels and inspect the installation locations before you cut and drill the holes required to mount the woofer. Removing the panel will also make it much easier to route wiring inside the door. Look for original equipment speaker installation cutouts that can be used to install the HCCA woofers with little or no modifications. Use the template supplied to help you locate and mark the holes needed to install the speakers.

If the planned installation location is in a door panel be sure the speaker will not interfere with the window lowering mechanism. Be sure that the speaker wires clear all moving parts inside the door.

For each woofer you will need to cut one large hole and drill small holes around the circumference. If the mounting surface is covered by carpet or fabric, use a knife or razor to cut the material away from the holes and cutting path. This prevents material or fibers from becoming tangled in the drill bit or cutting blade.

If you are using the sheet metal screws provided in the hardware kit, drill the four speaker mounting screw holes with a 1/8" / 3mm drill.

Clean the work areas of all filings and shavings with a vacuum cleaner before you proceed with woofer mounting.

## Woofer mounting

Route the speaker wire from the woofer installation locations to the crossovers. Pull the wire through the installation hole and attach the terminals on the ends to terminals on the speakers. Connect the positive wire to the positive (+) terminal, which is indicated by a "+" on the speaker magnet. See the information in the speaker wiring section of this manual and the wiring diagrams. Push the wire back into the area behind the installation location and be sure it will not interfere with the speaker.

Adhere the supplied foam gasket strip to the mounting surface of the speaker. This will ensure an air tight seal, which is required to achieve the best bass performance.

When installing the speakers drive the supplied sheet metal screws by gradually tightening them in turn. Drive the screws in until the speaker is well seated, but take care not to overtighten the screws.

Each of the HCCA woofers is installed in a slightly different way. See the following illustrations.

## Bi-amplified connections to the crossover network

If you have two 2 channel amplifiers or a 4 channel amp, the HCCA components can be bi-amplified. Each driver will have its own discrete channel of amplification. Connect the channel selected for the tweeter to the positive (IN+) and negative (IN-) inputs next to the tweeter outputs (T+ and T-). The woofer channel will be connected to IN+ and IN- inputs next to the woofer outputs (W+ and W-).

**Important note:** You must cut the red and black wire jumpers on each side of the crossover that connect the low and high frequency sections of the crossover. Failure to do so could cause damage to the amplifiers or the crossover.

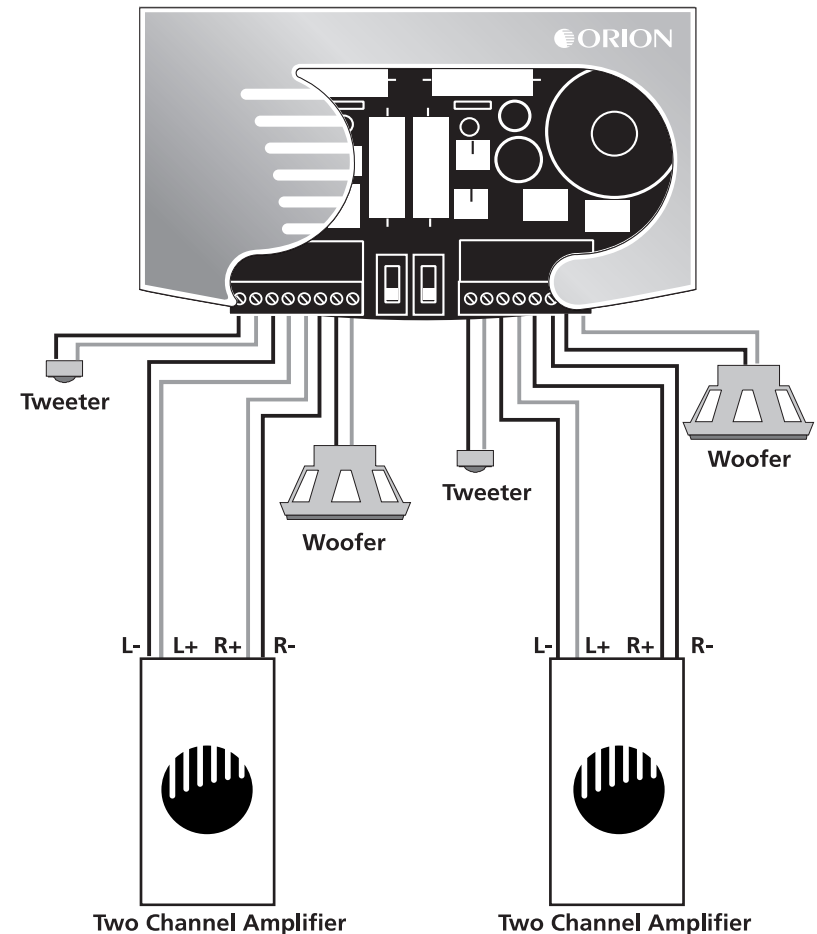



# CROSSOVER INSTALLATION

## Connecting the system

Trim the speaker wire as needed. Strip no more than 1/4" (6mm) of the insulation from the ends. Twist the exposed strands thoroughly to prevent any loose strands from causing a short circuit. If possible "tin" the wire with a soldering iron. Either the tweeter or woofer input of each connector can be used when not bi-wiring/bi-amping (when the bi-wire/bi-amp jumpers are not cut, the tweeter and woofer inputs are connected in parallel). Insert the wires in the removable connector and tighten screws.

Carefully route the wires from the HCCA tweeter and woofer to the crossover mounting location. The crossover installation location should be reasonably accessible to allow easy connection of the wires, tweeter level adjustment and tweeter phase selection. If the crossover must be mounted in an inaccessible location make the speaker wire connections and adjustments before final installation.

## Bi-wiring / Bi-amping

The HCCA competition system allows bi-wiring, or bi-amping using the supplied passive crossovers. While conventional wiring can provide excellent sound, bi-wiring or bi-amping will further enhance the performance in no-compromise systems.

Bi-wiring uses a separate pair of speaker wires for the high frequency and low frequency signal between an amplifier channel and its associated crossover network. This gives you the option of choosing wire which may have slightly different sonic characteristics in order to optimize performance of each frequency range. Also, it reduces the overall wiring resistance between the crossover and amplifier, much like the use of larger gauge wire. This option provides the most benefit when the crossover network is mounted a long distance away from the amplifier. If the crossover is mounted close to the amplifier it is doubtful that there will be an appreciable difference between bi-wiring and conventional wiring.

Bi-amping is similar to bi-wiring except that it uses a separate amplifier channel for the high-frequency and low-frequency sections, instead of the single amplifier channel used in conventional and bi-wired connections. Bi-amping provides the additional advantages of reducing amplifier distortion and allowing the amplifier's level controls to provide an additional level of fine-tuning not possible with the tweeter-level switch alone. In addition, at high power levels, a bi-amplified connection protects the tweeter from amplifier clipping, which is most likely to occur on channels driving the midrange, due to the higher energy levels of midrange signals. When bi-amping using the passive crossovers, the midrange low-pass filter and tweeter high-pass filter on the amplifier or external electronic crossover should be bypassed.

**Important note:** When bi-amping or bi-wiring, you must cut the red and black wire jumpers on each side of the crossover that connect the low and high frequency sections of the crossover. Failure to do so could cause damage to the amplifiers or the crossover.

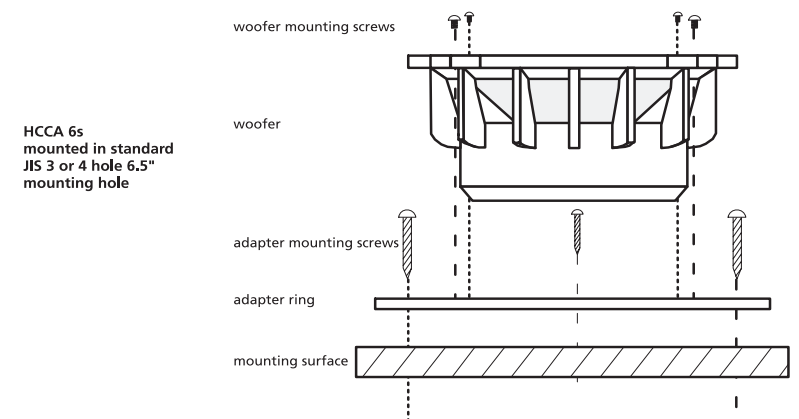
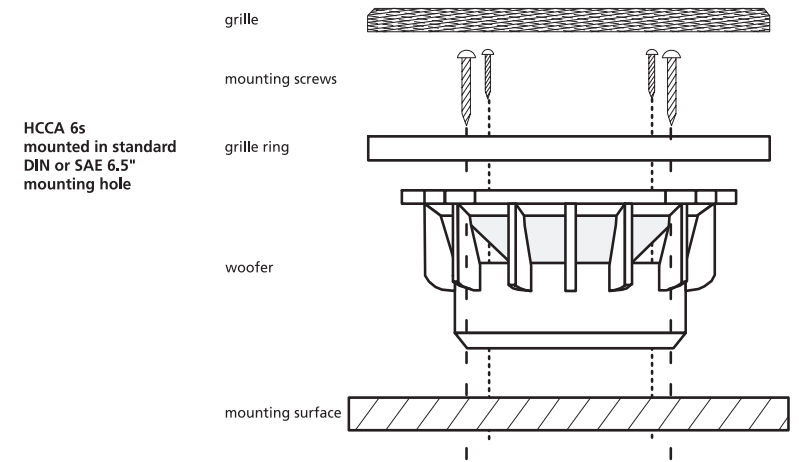
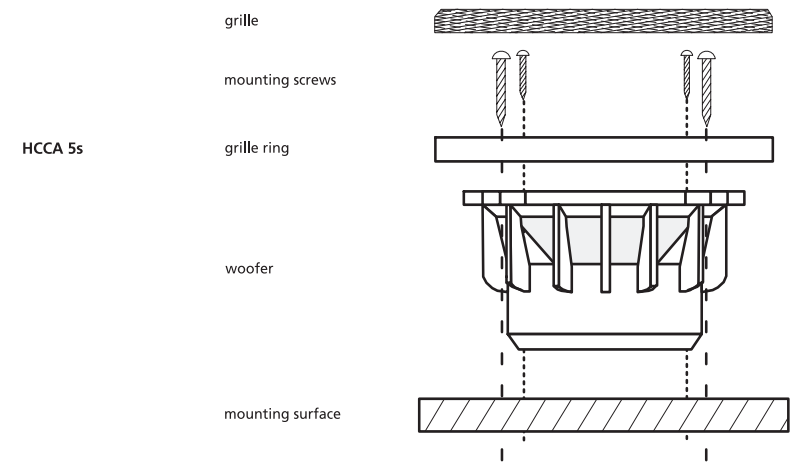

# TWEETER INSTALLATION

The HCCA speaker system is supplied with three different tweeter mounting options. Surface, flush and angled flush mount. After you have decided which option is best suited to your installation, refer to the following sections for specific details on mounting the tweeter.

## Surface mount

The preparation of the mounting surface for the tweeter involves drilling three holes. Two holes are for the mounting screws. Their centers must be spaced 15/16" / 24mm apart. Use a 1/8" / 3mm drill bit for the supplied flat head #6 X 3/4" screws to mount the cup. The third 1/4" / 7mm hole is required for the wire to pass through.

Use the template provided to locate the hole centers. Cut carpeting or fabric away from the hole locations to prevent tangling of fibers in the drill bit.

**Note:** The orientation of the three holes determines the installed position of the tweeter. The Orion logo on the surface mount cup will end up closest to the wiring hole as shown.

### Surface mount cup mounting

Insert two #6 X 3/4" flat head sheet metal screws through the holes in the bottom of the surface mount cup. Screw the cup in place. Be sure the mounting screws are driven in straight, so the heads sit flush on the cup mounting surface. This ensures the tweeter will seat properly in the surface mount cup.

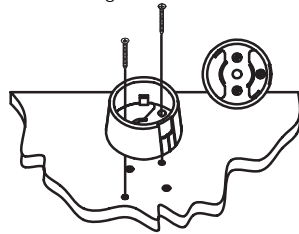

## Flush mount

Check the intended installation site to be sure that there is sufficient depth behind the mounting surface for the rear cup and mounting screws. The minimum depth required behind the back of the mounting surface is 1" / 25mm.

The front cup mounts into the mounting surface through a 1 7/8" / 48mm diameter hole. Be careful that the hole does not exceed 2 1/8" / 55mm diameter at any point so that the rim of the cup will completely cover the edge of the hole.

Use the template provided to locate the hole centers. Cut carpeting or fabric away from the cutting path to prevent tangling of fibers in the saw blade.

**Note:** Place enough washers over the protruding screws on the back of the front cup so that their combined thickness is somewhat less than the thickness of the mounting surface. This will ensure adequate "pinching" of the mounting cups without danger of breaking the rear cup.

### Flush mount and angled flush mount cup mounting

Insert two #6 X 3/4" flat head sheet metal screws through the holes in the bottom of the flush mount cup. Hold the back of the cup in place behind the hole cut in the panel and screw the front cup into the back cup. Use care not to overtighten the screws. Be sure the mounting screws are driven in straight, so the heads sit flush on the cup mounting surface. This ensures the tweeter will seat properly in the flush mount cup.

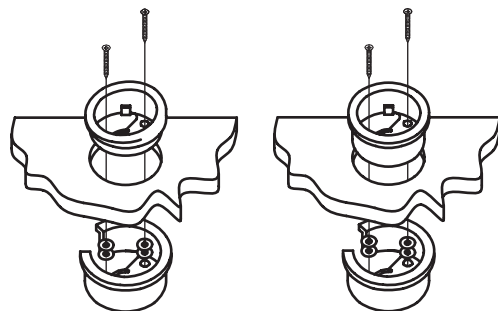

## Blind installation

In a blind installation, the rear of the mounting surface is inaccessible. Give some thought to the electrical connections. You may be able to fish the tweeter signal wire to the crossover network location after installation of the tweeter assembly. You may need to fish a signal wire from the crossover network location to, and then through, the mounting hole and the rear cup before the cup is inserted through the mounting hole. You can then connect the signal wire to the tweeter wire.

Once you have decided the signal wire connections, pass one supplied #6 x 1 1/2" long screw through the slotted hole in the front cup and turn a couple of threads into the rear cup. This will allow enough mobility of the two cups to allow the rear cup to be inserted through the mounting hole. The two cups can be screwed together using the long screw and a second #6 x 3/4" through the remaining hole to pinch the mounting surface between them.

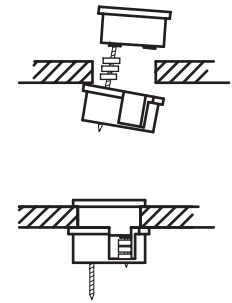

## Tweeter mounting

Route speaker wire from the crossover locations to the tweeter locations. Pull the wire through the wire hole and attach crossover wires to the wires from the tweeters. Connect the positive wire to the positive (+) terminal on the tweeter, which is marked with a red wire. See the information in the speaker wiring section of this manual and the wiring diagrams. Push the wire back into the area behind the installation location and be sure it will not interfere with the speaker or with anything behind the mounting panel.

To attach the tweeter to the surface or flush mount cup, align the tabs in the mounting cup with the relieved areas in the tweeter module. The wires should line up just to the right side of where the Orion/ nameplate is located on the surface mount cup.

**Note:** Once the surface mount cup is attached to the mounting surface, there is only one position in which the tweeter can be properly seated into the surface mount cup.

Gently push the tweeter into the mounting cup, take up the slack in the wire, and twist clockwise until it moves no further. Do not force the unit if it does not turn freely. If the tweeter is not lined up properly with the tabs or the wire is interfering, the tweeter will not fully seat into the cup.

To remove the tweeter, simply turn it counterclockwise, and pull the tweeter away from the cup.

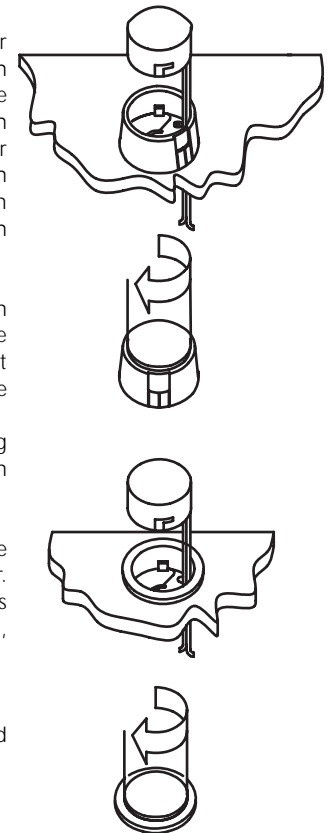

## Free Manuals Download Website

<http://myh66.com>

<http://usermanuals.us>

<http://www.somanuals.com>

<http://www.4manuals.cc>

<http://www.manual-lib.com>

<http://www.404manual.com>

<http://www.luxmanual.com>

<http://aubethermostatmanual.com>

Golf course search by state

<http://golfingnear.com>

Email search by domain

<http://emailbydomain.com>

Auto manuals search

<http://auto.somanuals.com>

TV manuals search

<http://tv.somanuals.com>