



OEM - 2

Universal sound system interface and controller

The OEM-2 may be used in any one of four possible configurations and system types.

- 1) Replacing a premium factory radio with an aftermarket stereo and use the factory amplifier and speakers.
- 2) Four channel line out converter for adding amplifiers to a standard factory speaker system.
- 3) Adding aftermarket amplifiers to a factory premium amplified system (Bose, JBL, etc.).
- 4) Installing a radio with floating ground speaker outputs to a common grounded speaker system like the early Fords.

The OEM-2 also includes a remote turn-on for amplifiers or a power antenna, providing 2 amps at 12 volts when 0.8 volts or greater is applied to the input side. This is useful for low voltage triggers like those used in Fords or for automatic triggering when audio is present. The output "turn on" is delayed 1 second to prevent turn on pops.

Input wiring colors		Output wiring colors	
White ¹	LF (+) speaker (high power)	White ⁶	LF (+) low level output
White/red ²	LF (+) speaker (low power)	White/red	LF (+) common gnd. speaker output
White/black ³	LF (-) common	White/black ⁷	LF (-) common
Gray ¹	RF (+) speaker (high power)	Gray ⁶	RF (+) low level output
Gray/red ²	RF (+) speaker (low power)	Gray/red	RF (+) common gnd. speaker output
Gray/black ³	RF (-) common	Gray/black ⁷	RF (-) common
Green ¹	LR (+) speaker (high power)	Green ⁶	LR (+) low level output
Green/red ²	LR (+) speaker (low power)	Green/red	LR (+) common gnd. speaker output
Green/black ³	LR (-) common	Green/black ⁷	LR (-) common
Violet ¹	RR (+) speaker (high power)	Violet ⁶	RR (+) low level output
Violet/red ²	RR (+) speaker (low power)	Violet/red	RR (+) common gnd. speaker output
Violet/black ³	RR (-) common	Violet/black ⁷	RR (-) common
Yellow ⁴	Constant battery	Yellow	Constant battery
Red ⁴	Switched power	Red	Switched power
Black ⁴	Gnd. neg. power	Black	Gnd. neg. power
Blue ⁴	Power antenna turn on	Blue	Power antenna turn on
Blue/white ⁵	Amplifier remote turn on 0.8 v min.	Blue/white	Amplifier remote turn on 2 amps max.
Orange ⁴	Illumination dimming	Orange	Illumination dimming

¹ Connect these wires to an aftermarket radio (+) high power speaker output (typically 20 watts x 4 and higher).

² Connect these wires to an aftermarket radio (+) low power speaker output. (All stereos up to 20 watts x 4 or when wiring for #4)

³ If the radio is high power (floating ground), connect these wires separately to each of the radio's speaker (-) wire (do not connect (-) speaker wires together). If the radio has a common ground speaker outputs, connect these wires together along with the radio's speaker ground.

⁴ These wires go directly through to the outputs for convenience of wiring. The red and black wires supply power to the internal low voltage trigger.

⁵ This wire needs only a minimum of 0.8 volts to supply 12 volts on the blue/white wire on the output side of the OEM-2.

⁶ For convenience, the positive leads of the RCA are connected internally to these wires.

⁷ For convenience, the grounds of the RCA are connected internally to these wires. Not used with common grounded speakers.

Note: Some Chrysler/Dodge vehicles with a Infinity premium sound system do not need any interface. If the speakers fade and balance correctly with this interface installed, but you have very little volume, then you do not need this interface.

1) Replace the factory premium radio with an after market radio/deck and retain the use of the factory amplifiers and speakers

Referring to the wire color chart above, connect the speaker outputs of the new radio to the OEM-2, using the positive, solid color, and the negative black-striped wires for all four channels. On the output side of the OEM-2 connect the solid color wires (+) and the black-striped wires (-) to the factory harness leading to the factory amplifiers. If there are common audio return wires (-) used in the vehicle for either the front and rear channels then connect the negative outputs of the OEM-2 to them. If there is only one audio return wire for all four channels connect all the black-striped wires to it. Connecting the constant power (yellow), switched power (red), ground (black), antenna trigger (blue), illumination (orange), and amplifier turn on (blue/white) through the OEM-2 simplifies wiring to the vehicle. The output level controls can be adjusted with a small screwdriver.

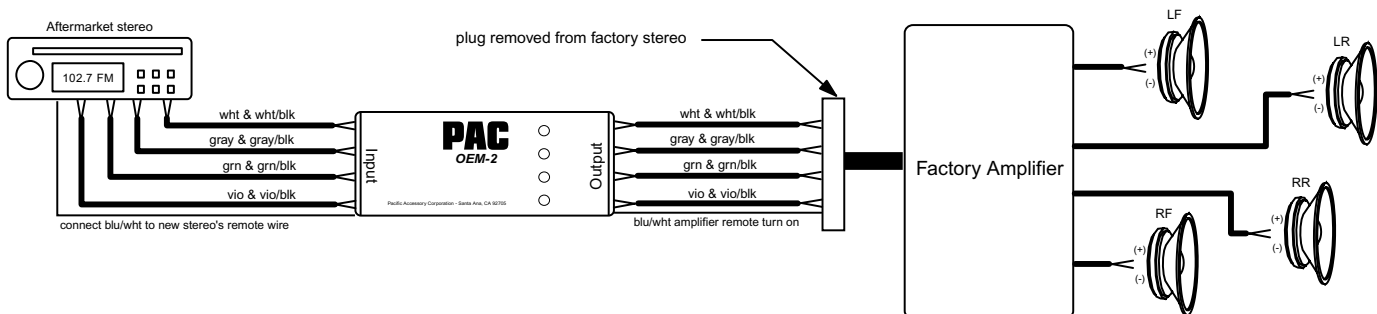

2) Adding an aftermarket amplifier to a standard factory radio that does not have factory amplifiers

The factory radio speaker outputs are connected to the OEM-2 inputs and the new amplifier is connected to the output side of the OEM-2, using the four RCA jacks and extension cables. Referring to the wire color chart, connect the factory radio speaker (+) outputs to the solid color wires and the (-) outputs to the black-striped wires. Example, LF speaker outputs of the factory radio connect to the white wire (+) and white/black (-). Continue for the remaining channels. The OEM-2 provides an amplifier turn on signal. To use, connect the blue/white wire on the OEM-2 input side to one of the positive speaker wires or to any source that provides 5 volts DC or greater. The blue/white wire on the output side will provide 12 volts to turn on the new amplifier. Connect the red (+) and black (-) wires on the input side to switched vehicle power and ground. Adjust the output level controls as needed using a small screwdriver.

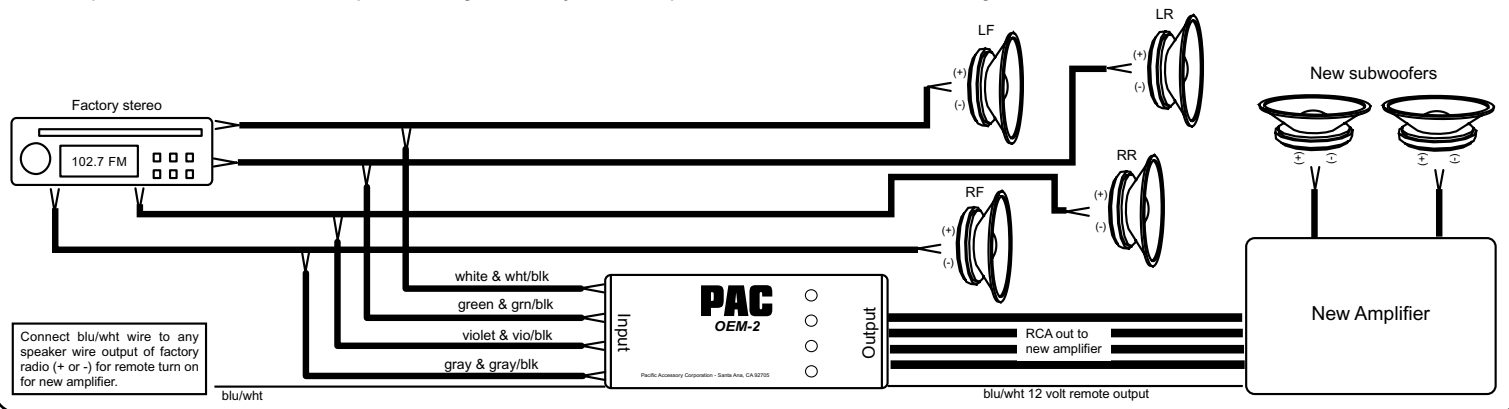

3) Adding after market amplifiers to a factory premium amplified system (Bose, JBL, etc.)

Referring to the wire color chart above, connect the audio output leads of the factory stereo to the input of the OEM-2, using the red striped wires as the positive input and black-striped as negative. Most premium systems use a low -level signal from the stereo to the factory amplifiers, therefore use the low level input of the OEM-2. Some factory-amplified systems use common audio returns and grounded shields like for instance, GM/Delco Bose vehicles. Do not cut the shield wire or attempt to use it as an audio signal wire. Determine if your system has two common audio return wires, one for the front channels and a second for the rear channels. If so, connect the negative input wires (black-stripe) for the front channels of the OEM-2 to the common audio return wire in the vehicle for the front channels. Do the same for the rear channels. If the vehicle has only one audio return wire for all channels connect all of the black striped wires to it. The output level controls can be adjusted with a small screwdriver. Connect the red (+) and black (-) wires on the input side to switched vehicle power and ground.

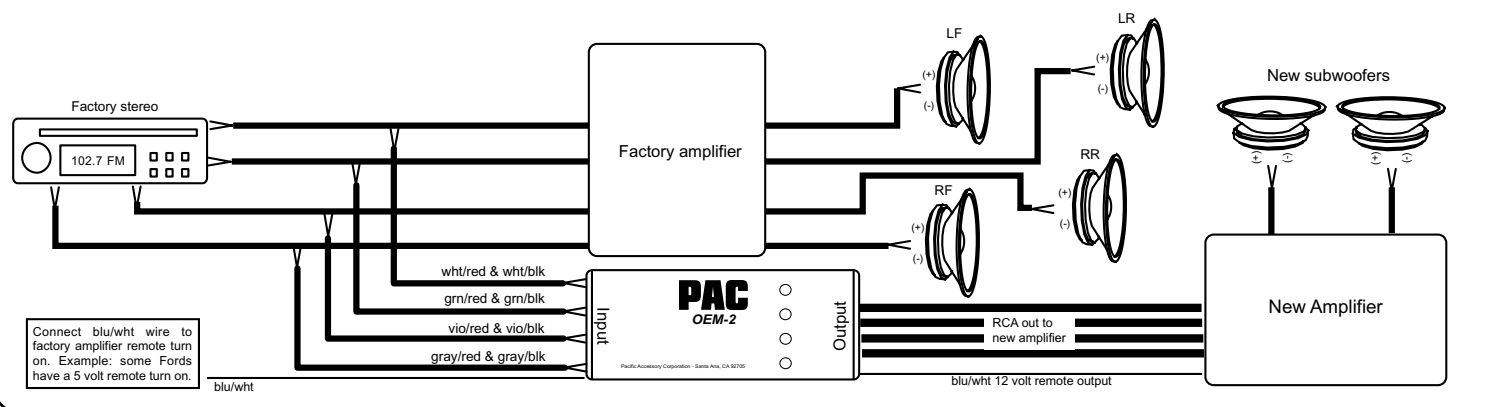

4) Installing a radio with floating ground speaker outputs to a common grounded speaker system like the early Fords.

Referring to the wire color chart, connect the new stereo positive speaker outputs to the red striped wire on the input side of the OEM-2. Connect the negative speaker outputs to the black-striped wires of the OEM-2. On the output side of the OEM-2 connect the red-striped wires to the vehicle positive speaker wiring. The black striped wires on the output are not used. The negative side of each speaker is either common to each other on one wire or two in the factory plug or already grounded to the chassis. However it may be, make sure that they are grounded to the vehicle chassis. The output level control on the OEM-2 will not function in this configuration.

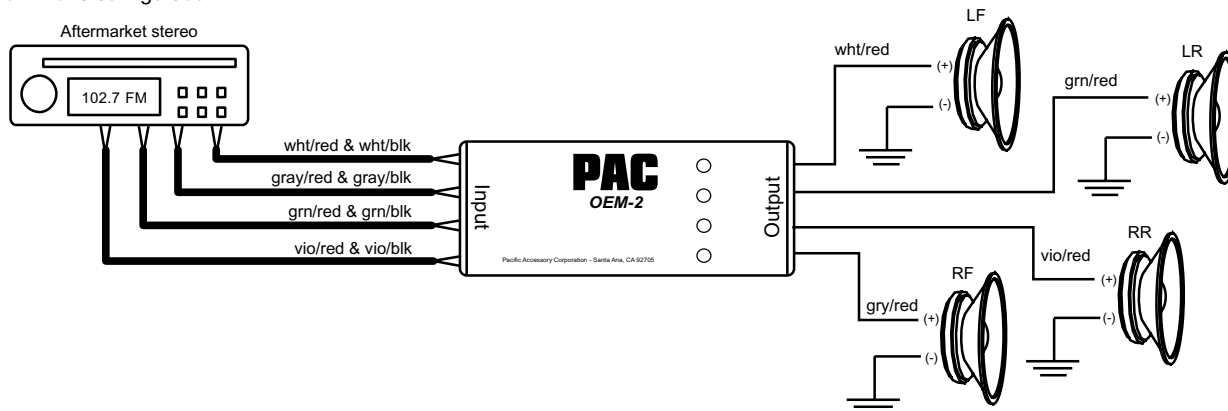



Wiring the OEM-2 and aftermarket stereo to a GM factory Bose Premium Sound System

Mobile Audio Interfacing Equipment

Important!

If you are using the supplied wire harness from Crutchfield, or other aftermarket wire harness either from Metra, Scosche or American International, you can not connect the audio signal wires of the supplied wire harness to the OEM-2 color for color (you may however, connect the red, black, blue, orange, and yellow wire color for color). The wire harness supplied by Crutchfield or other above mentioned wire harnesses are not designed for Bose Premium Sound Systems. You will need to trace the factory wire colors and match them over to the aftermarket harness. Connect the OEM-2 outputs according to the chart.

The factory wire colors given are typical of most GM vehicles with a Bose Premium Sound System. If the colors do not match up, you will need to obtain a wiring diagram of your vehicle from a dealer. In some vehicles the audio common wires could have a striped wire.

NOTES: 4 possible GM plug configurations.

GM21 and GM21A: has a bare shield wire for both front a rear speakers.

GM21B: has no bare shield wire and has common wires for front and rear.

GM21C: has a positive and negative wire for each speaker.

Use the shield wire(s) as a guide to determine which chart to use.

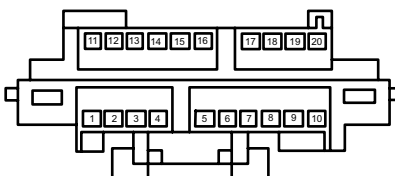

Factory GM 21 pin plug

Viewed from pin side not wire side

Factory plug. Connect these wires to →	OEM-2
GM21	
1 = front audio shield, bare wire	black wire
2 = left front positive (LF+), tan	wht wire
3 = right and left front common (-), lt. grn	wht/blk and gry/blk wires
4 = right front positive (RF+), dark green	gry wire
5 = chassis ground, black	black wire
6 = illumination/dimmer, gray	orange wire
7 = n/a	n/a
8 = remote turn on, pink	blue/wht
9 = 12 volt ignition/switched (+12), yellow	red wire
10 = 12 volt battery/constant (+12), orange	yellow wire
17 = rear audio shield, bare wire	black wire
18 = right rear positive (RR+), dark blue	purple wire
19 = right and left rear common (-), yellow	prp/blk and grn/blk wires
20 = left rear positive (LR+), dark brown	grn wire

Factory plug. Connect these wires to →	OEM-2
GM21B	
1 = n/a	n/a
2 = left front positive (LF+), tan	wht wire
3 = n/a	n/a
4 = right front positive (RF+), dark green	gry wire
5 = chassis ground, black	black wire
6 = illumination/dimmer, gray	orange wire
7 = n/a	n/a
8 = remote turn on, pink	blue/wht
9 = 12 volt ignition/switched (+12), yellow	red wire
10 = 12 volt battery/constant (+12), orange	yellow wire
17 = audio common	prp/blk, wht/blk, gry/blk and grn/blk wires
18 = right rear positive (RR+), dark blue	purple wire
19 = n/a	n/a
20 = left rear positive (LR+), dark brown	grn wire

Factory plug. Connect these wires to →	OEM-2
GM21A	
1 = left front positive (LF+), tan	wht wire
2 = right and left front common (-), lt. grn	wht/blk and gry/blk wires
3 = right front positive (RF+), dark green	gry wire
4 = front audio shield, bare wire	black wire
5 = chassis ground, black	black wire
6 = illumination/dimmer, gray	orange wire
7 = n/a	n/a
8 = remote turn on, pink	blue/wht
9 = 12 volt ignition/switched (+12), yellow	red wire
10 = 12 volt battery/constant (+12), orange	yellow wire
17 = right rear positive (RR+), dark blue	purple wire
18 = right and left rear common (-), yellow	prp/blk and grn/blk wires
19 = left rear positive (LR+), dark brown	grn wire
20 = rear audio shield, bare wire	black wire

Factory plug. Connect these wires to →	OEM-2
GM21C	
1 = left front negative (LF-), gray	wht/blk wire
2 = left front positive (LF+), tan	wht wire
3 = right front negative (RF-), dark green	gry/blk wire
4 = right front positive (RF+), lt. green	gry wire
5 = chassis ground, black	black wire
6 = illumination/dimmer, gray	orange wire
7 = n/a	n/a
8 = remote turn on, pink	blue/wht
9 = 12 volt ignition/switched (+12), yellow	red wire
10 = 12 volt battery/constant (+12), orange	yellow wire
17 = right rear negative (RR-), lt. blue	yellow wire
18 = right rear positive (RR+), dark blue	purple wire
19 = left rear negative (LR-), yellow	purple wire
20 = left rear positive (LR+), brown	grn/blk wire

Document and Material Disclaimer: All information, including photos and illustrations, in these pages is believed to be correct and reliable. The information contained in these pages is given as general information for the installation of audio accessories into mobile and/or vehicle applications. PACIFIC ACCESSORY CORPORATION shall not be held liable for any damages and/or injuries resulting from the use of information contained in these pages. All information contained in these pages should be checked and verified with appropriate test equipment to assure the safety and proper operation of equipment installed and the vehicle itself.

Copyright © 2002 Pacific Accessory Corporation.

NOTES: 2 possible plug configurations.
GM32: has one audio shield wire.
GM32A: has two audio shield wires.
 Use the shield wire(s) as a reference to select which chart to use.

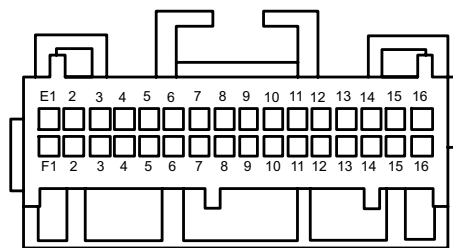

Factory GM 32 pin plug
 Viewed from pin side not wire side

GM32		GM32A	
Factory plug. Connect these wires to →	OEM-2	Factory plug. Connect these wires to →	OEM-2
Row E		Row E	
1 = n/a	n/a	1 = n/a	n/a
2 = n/a	n/a	2 = n/a	n/a
3 = remote turn on	blue/wht wire	3 = remote turn on	blue/wht wire
4 = n/a	n/a	4 = n/a	n/a
5 = n/a	n/a	5 = n/a	n/a
6 = n/a	n/a	6 = n/a	n/a
7 = n/a	n/a	7 = n/a	n/a
8 = n/a	n/a	8 = n/a	n/a
9 = n/a	n/a	9 = n/a	n/a
10 = n/a	n/a	10 = n/a	n/a
12 = left rear positive (LR+)	grn wire	12 = left rear positive (LR+)	grn wire
13 = n/a	n/a	13 = rear audio shield, bare wire	black wire
14 = n/a	n/a	14 = rear audio common return (-)	prp/blk and grn/blk wire
15 = right rear positive (RR+)	prp wire	15 = right rear positive (RR+)	prp wire
16 = chassis ground	black wire	16 = chassis ground	black wire
Row F		Row F	
1 = constant 12 volts	yellow wire	1 = constant 12 volts	yellow wire
2 = accessory 12 volts	red wire	2 = accessory 12 volts	red wire
3 = antenna remote turn on	blue wire	3 = antenna remote turn on	blue wire
4 = illumination/dimmer	orange	4 = illumination/dimmer	orange
5 = n/a	n/a	5 = n/a	n/a
6 = n/a	n/a	6 = n/a	n/a
7 = n/a	n/a	7 = n/a	n/a
8 = n/a	n/a	8 = n/a	n/a
9 = n/a	n/a	9 = n/a	n/a
10 = n/a	n/a	10 = n/a	n/a
12 = left front positive (LF+)	wht wire	12 = left front positive (LF+)	wht wire
13 = audio shield, bare wire	black wire	13 = front audio shield, bare wire	black wire
14 = audio common return (-)	prp/blk, grn/blk, gry/blk and wht/blk wires	14 = front audio common return (-)	gry/blk and wht/blk wires
15 = right front positive (RF+)	gry wire	15 = right front positive (RF+)	gry wire
16 = n/a	n/a	16 = n/a	n/a

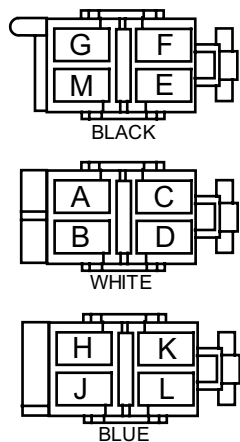

Factory plug. Connect these wires to →	OEM-2
A = right front positive (RF+), lt. grn	gry wire
B = left front positive (LF+), tan	wht wire
C = front shield, bare wire	black wire
D = right front negative, left front negative	gry/blk and wht/blk wire
E = remote turn on, pink	blue/wht wire
F = 12 volt ignition/switched (+12), yellow	red wire
G = ground, black	black wire
H = left rear positive (LR+), brown	green wire
J = right rear positive (RR+), dark blue	prp wire
K = left rear negative, right rear negative	prp/blk and grn/blk wire
L = rear shield, bare wire	black wire
M = illumination/dimmer, gray	orange wire
on separate two pin, white plug, orange wire is constant 12 volts.	yellow wire

Late 1984 and later models only

Viewed from pin side not wire side

Free Manuals Download Website

<http://myh66.com>

<http://usermanuals.us>

<http://www.somanuals.com>

<http://www.4manuals.cc>

<http://www.manual-lib.com>

<http://www.404manual.com>

<http://www.luxmanual.com>

<http://aubethermostatmanual.com>

Golf course search by state

<http://golfingnear.com>

Email search by domain

<http://emailbydomain.com>

Auto manuals search

<http://auto.somanuals.com>

TV manuals search

<http://tv.somanuals.com>