

MATSUSHITA Compressor

MODEL# DD73C14GBU6

Single Phase
R-134a

115 V
60 Hz

Voltage Range 103 Volts to 127 Volts @ 60 Hz
Application Low Back Pressure
Compressor Cooling Fan Cooling

Refrigerant Control . . . Capillary Tube
Evaporator
Temp. Range -31°F to 23°F / -35°C to -5°C

Rated Performance Data

	Cond. Temp I*	Cond. Temp II*
Capacity	881 Btu/h ±7%	973 Btu/h ±7%
E.E.R.	4.84 Btu/Wh ±7%	5.62 Btu/Wh ±7%
Current	2.29 Amps	2.18 Amps

Nominal Motor Data

Motor Input	182 Watts	173 Watts
Rated Current	2.22 Amps	
Type	RSCR, PTC relay	

Locked Rotor	16.9 Amps
Start Current	23.8 Amps
Coil Resistances	Run . . . 2.71 Ohms
@ 68°F (20°C)	Start . . . 5.88 Ohms

*Test Conditions for Performance Specifications

Test Oil	ISO VG 10
Shell Temp	170.0°F / 76.0°C
Condensing Temp	(I) 130.0°F / 54.4°C
	(II) 105.0°F / 40.6°C
Evaporating Temp	-10.0°F / -23.3°C
Ambient Temp	90.0°F / 32.2°C
Gas Superheat	90.0°F / 32.2°C
Liquid Sub-Cooling	90.0°F / 32.2°C

Electrical Accessories†

Overload Protector
Nominal Operating Characteristics

Model Name	4TM762MFBYY
Manufacturer	Texas Instruments
Temperature To	Open: 239°F ± 9°F / 115°C ± 5°C
	Close: 142°F ± 16°F / 61°C ± 9°C
Trip Current	@ 158°F (70°C) 4.20 Amps ± 7.5%
	@ 77°F (25°C) 14.0 Amps @ 18 sec. max.

P.T.C. Starting Device

Nominal Operating Characteristics

Model Name	PTH490C-AS6R8	
Manufacturer	Murata Mfg.	
Base resistance		
@ 77°F(25°C) ±20%	6.8	Ohms
Power Consumption (max)	3.5	Watts
Operation time	1.0 to 2.7	seconds
Recovery time (max)	65	seconds

Run Capacitor — μF — V

†Although these accessories are listed by UL/CSA for use with this compressor, Matsushita assumes no responsibility whatsoever for these or any other components sourced by the refrigeration system manufacturer from third parties.

Performance Curves

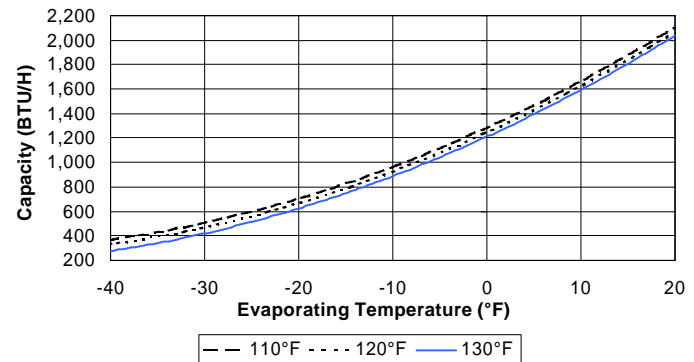
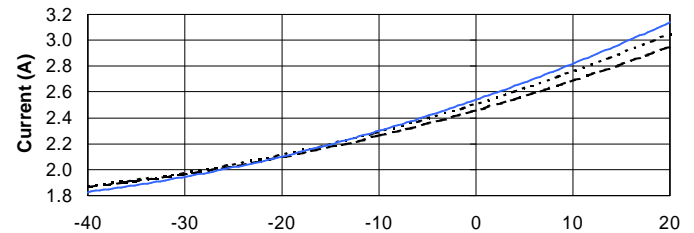
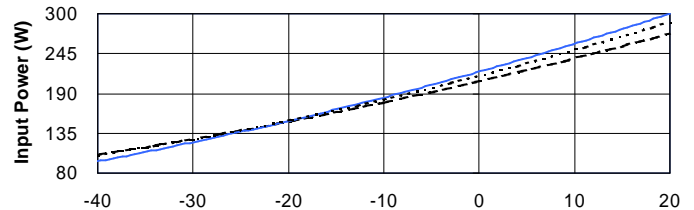

9 - Point Data

		Evaporating Temp.		
Condensing Temp.	Rating	-30°F	-10°F	+10°F
130°F	Btu/h	420	884	1,594
	Watts	123	182	259
	Amps	1.94	2.29	2.82
	E.E.R.	3.42	4.84	6.16
120°F	Btu/h	468	925	1,625
	Watts	127	182	249
	Amps	1.97	2.29	2.76
	E.E.R.	3.69	5.10	6.51
110°F	Btu/h	505	963	1,663
	Watts	127	177	238
	Amps	1.96	2.26	2.69
	E.E.R.	3.98	5.43	6.98

Panasonic®

Panasonic Industrial Company
Refrigeration Products Department
Tel: 201 - 392 - 4249
Fax: 201 - 392 - 4315

Rev#1-5/9

MATSUSHITA Compressor

MODEL# DD73C14GBU6

Single Phase
R-134a

115 V
60 Hz

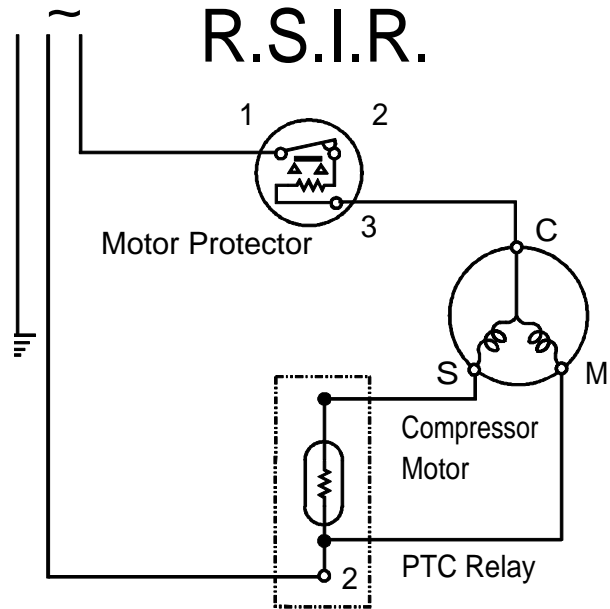
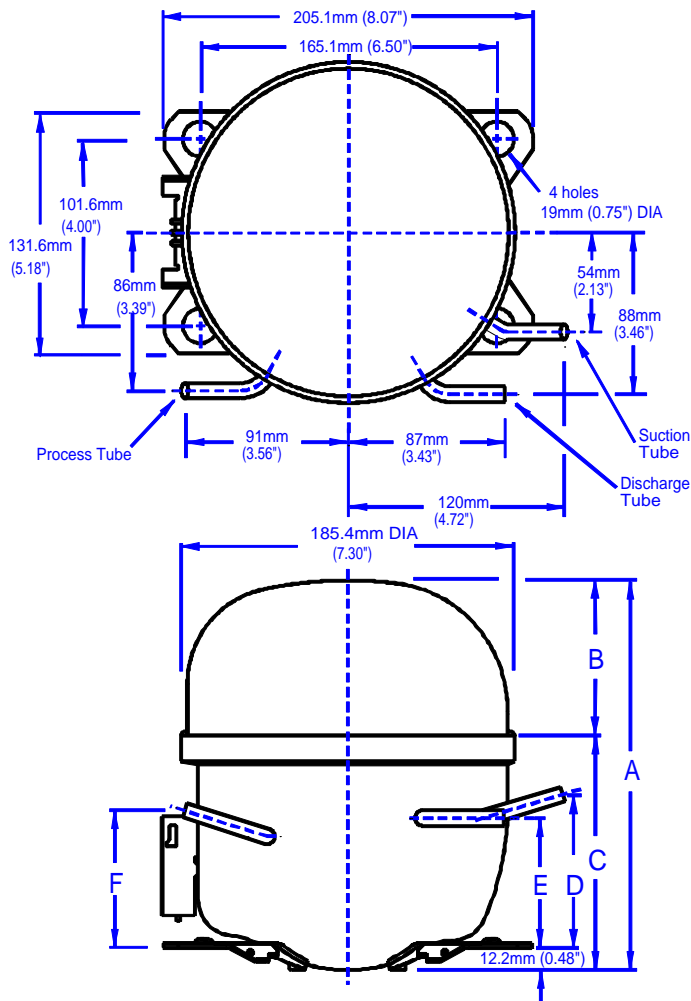

Dimensions*

	mm	inches
A	211.8	8.34
B	84.2	3.31
C	127.6	5.02
D	83.9	3.30
E	70.4	2.77
F	75.2	2.96

* All dimensions are for reference only

This document sets forth certain operational parameters and conditions for operation of this product. If this product is operated outside of the parameters and conditions stated herein, buyer assumes sole and full responsibility and shall indemnify seller with respect to all product failures and all consequences thereof. Operation of the product outside of the parameters and conditions specified herein shall serve to invalidate all seller warranties, if any, with respect to the product. This document is for reference only. For specifications, please contact Panasonic's engineering department.

Tubes	Tube O.D.	Wall	Material
Suction	0.33 in. / 8.3 mm	0.035 in. / 0.9 mm	Copper
Process	0.33 in. / 8.3 mm	0.035 in. / 0.9 mm	Copper
Discharge	0.33 in. / 8.3 mm	0.035 in. / 0.9 mm	Copper

U.L. File # SA 4615
C.S.A. File #'s LR - 36593

General Data	Oil Charge	Net Weight With Oil	Approved Oils:
	250 cc ± 5 cc / 15.3 cu.in. ± 0.3 cu.in.	22.0 lbs, 10.0 kg	FREOL . . . α 10, α 10E, α 15, α 15E, α 22, α 22E
			ICI RL10H, RL15H, RL22H
			HENKEL ProEco 10S, 15S, 22S
			Residual Moisture 120 mg max.
			Impurities 10 mg max.
			Displacement 7.27 cc. / 0.444 cu. in.

Panasonic®

Panasonic Industrial Company
Refrigeration Products Department
Tel: 201 - 392 - 4249
Fax: 201 - 392 - 4315

Rev#1-5/9

Free Manuals Download Website

<http://myh66.com>

<http://usermanuals.us>

<http://www.somanuals.com>

<http://www.4manuals.cc>

<http://www.manual-lib.com>

<http://www.404manual.com>

<http://www.luxmanual.com>

<http://aubethermostatmanual.com>

Golf course search by state

<http://golfingnear.com>

Email search by domain

<http://emailbydomain.com>

Auto manuals search

<http://auto.somanuals.com>

TV manuals search

<http://tv.somanuals.com>