

Service Manual

Air Conditioner

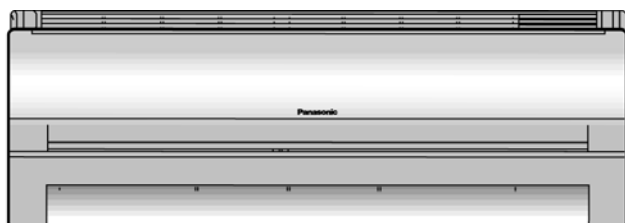

CS-C9DKU CU-C9DKU
CS-C12DKU CU-C12DKU



⚠ WARNING

This service information is designed for experienced repair technicians only and is not designed for use by the general public. It does not contain warnings or cautions to advise non-technical individuals of potential dangers in attempting to service a product. Products powered by electricity should be serviced or repaired only by experienced professional technicians. Any attempt to service or repair the product or products dealt with in this service information by anyone else could result in serious injury or death.

CONTENTS

	Page		Page
1 Features	2	8.5. Indoor Fan Speed Control	21
2 Functions	3	8.6. Outdoor Fan Speed Control	23
3 Product Specifications	6	8.7. Vertical Airflow Direction Control	23
3.1. CS-C9DKU CU-C9DKU	6	8.8. Horizontal Airflow Direction Control	24
3.2. CS-C12DKU CU-C12DKU	8	8.9. Powerful Operation	24
4 Dimensions	10	8.10. Quiet Operation	25
4.1. Indoor Unit & Remote Control	10	8.11. Timer Control	26
4.2. Outdoor Unit	11	8.12. Random Auto Restart Control	26
5 Refrigeration Cycle Diagram	12	8.13. Remote Control Signal Receiving Sound	26
6 Block Diagram	13	8.14. Economy Mode Operation	27
7 Wiring Diagram	14	9 Operating Instructions	28
8 Operation Details	15	10 Installation Instructions	34
8.1. Cooling Operation	15	10.1. Safety Precautions	34
8.2. Soft Dry Operation	16	10.2. Attached accessories	36
8.3. Automatic Operation	17	10.3. Select the best location	36
8.4. Operation Control	18	10.4. Indoor/Outdoor Unit Installation Diagram	36

Panasonic®

© 2005 Panasonic HA Air-Conditioning (M) Sdn Bhd (11969-T). All rights reserved. Unauthorized copying and distribution is a violation of law.

10.5. Indoor unit	37	13 Troubleshooting Guide	57
10.6. Outdoor unit	40	13.1. Refrigeration cycle system	57
11 2-way, 3-way Valve	45	13.2. Relationship between the condition of the air conditioner and pressure and electric current	58
11.1. Evacuation of Installation	46	13.3. Diagnosis methods of a malfunction of a compressor ----	58
11.2. Pumping down	47	14 Technical Data	59
11.3. Evacuation of Re-installation	48	14.1. Thermostat characteristics	59
11.4. Balance refrigerant of the 2-way, 3-way valves	49	14.2. Operation characteristics	60
11.5. Evacuation	50	15 Exploded View (Indoor Unit)	64
11.6. Gas charging	51	16 Replacement Parts List (Indoor Unit)	65
12 Servicing Information	52	17 Exploded View (Outdoor Unit)	66
12.1. Distinction of Lead Free (PbF) Printed Circuit Board	52	18 Replacement Parts List (Outdoor Unit)	67
12.2. Indoor Electronic Controller Removal Procedures	52	19 Electronic Circuit Diagram	68
12.3. Indoor Fan Motor and Cross Flow Fan Removal Procedures	54	19.1. Indoor Unit	68
12.4. Auto OFF/ON Button	55	19.2. Remote Control	74
12.5. Remote Control Reset	56	19.3. Print Pattern Indoor Unit Printed Circuit Board	75

1 Features

- **High Efficiency**
- **Compact Design**
- **Wider range of horizontal discharge air.**
- **Air Filter with function to reduce dust and smoke.**
- **Automatic air swing and manual adjusted by Remote Control for vertical airflow.**
- **Long installation piping.**
 - CS/CU-C9DKU, long piping up to 33ft.
 - CS/CU-C12DKU, long piping up to 49ft.
- **Quality Improvement**
 - Random auto restart after power failure for safety restart operation.
 - Gas leakage protection.
 - Prevent Compressor reverse cycle.
 - Inner protector to protect Compressor.
 - Noise prevention during soft dry operation.
 - Blue Coated Condenser for high resistance to corrosion.
- **Operation Improvement**
 - Quiet mode to provide quiet operation.
 - Powerful mode to reach the desired room temperature quickly.
 - 24-hour timer setting.
- **Serviceability Improvement**
 - Removable and washable Front Panel.

2 Functions

Remote Control

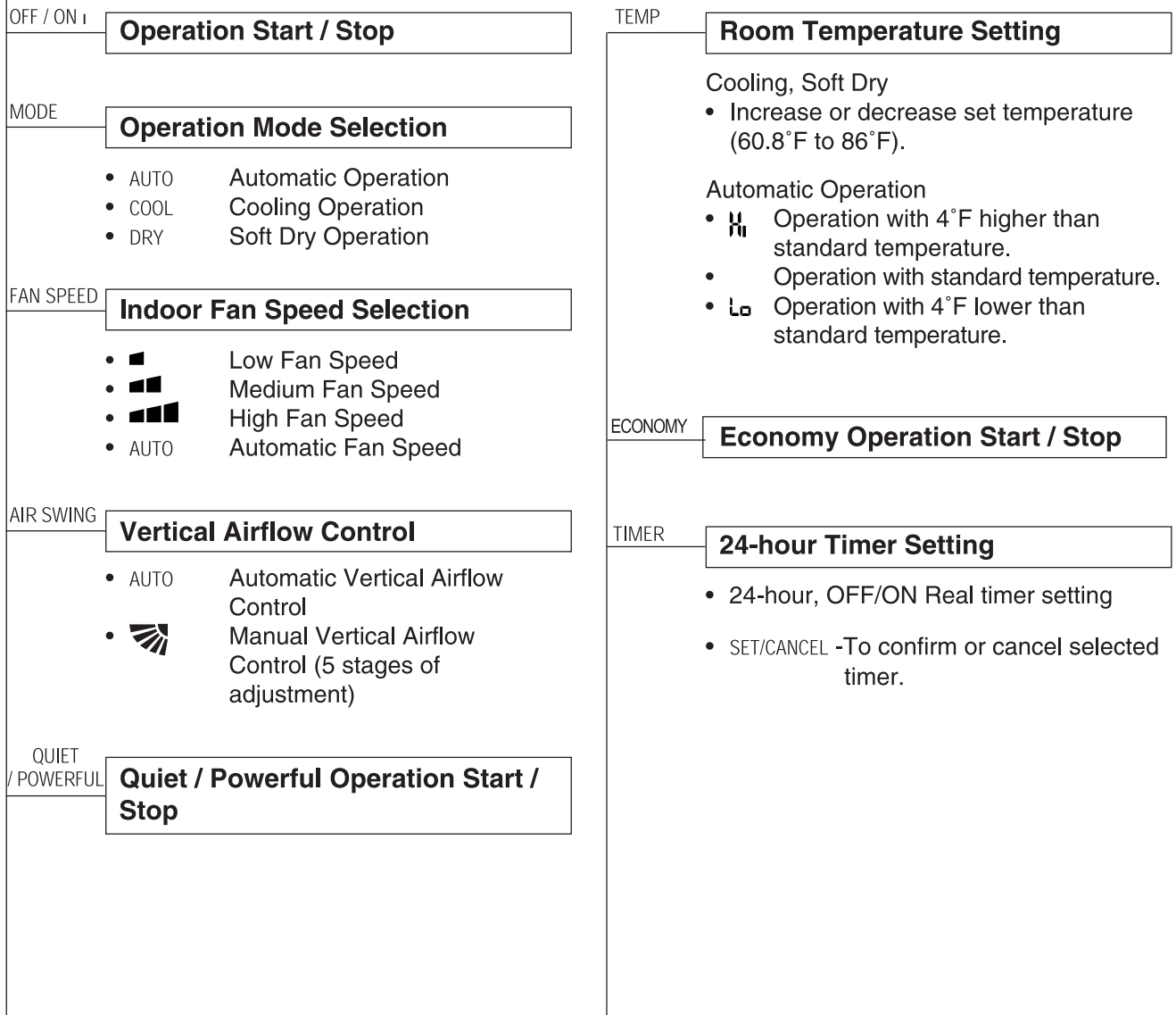
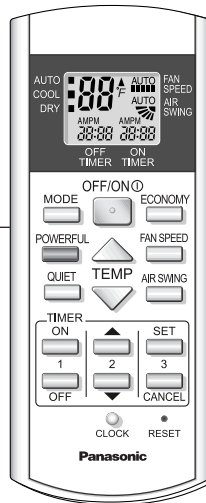

Indoor Unit

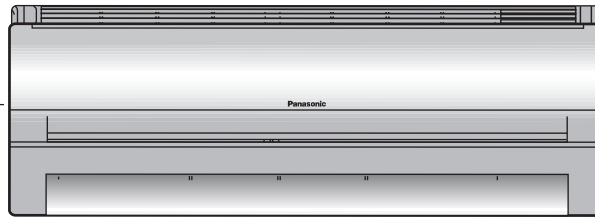

Auto Operation Button

- Press for < 5 second to operate Automatic operation mode. Use when the remote control cannot be used.
- Press for ≥ 5 second to operate Cooling operation mode and compressor force to on ("beep" sound will be heard). Used when test running or servicing.
- Within 20's of Cooling operation, press continuously for ≥ 5 second to enter various setting mode. "beep, beep" sound will be heard. (Used to toggle remote control signal receiving sound or select remote control transmission code.)

Operation Indication Lamps (LED)

- POWER (Green) Lights up in operation, blinks in Automatic Operation judging.
- TIMER (Orange) Lights up in Timer Setting.
- QUIET (Orange) Lights up in Quiet Operation.
- POWERFUL (Orange) ... Lights up in Powerful Operation.
- ECONOMY (Green)..... Lights up in Economy Operation.

Operation Mode

- Cooling, Soft Dry and Automatic Operation.

Timer

- OFF/ON.

Powerful Operation

- Reaches the desired room temperature quickly.

Quiet Operation

- To provide quiet operation.

Random Auto Restart Control

- Unit will be restarted, when resume from power failure, at previous setting.

Anti-Freezing Control

- To prevent indoor heat exchanger from freezing.

Economy Operation

- To reduce electrical power consumption.

Indoor Fan Speed Control

- Manual control fan speed (High, Medium and Low)
- Automatic fan speed.

Airflow Direction Control

- Automatic air swing and manual adjusted by remote control for vertical airflow.
- Manually adjusted by hand for horizontal airflow.

Time Delay Safety Control

- Restarting is inhibited for approximately 3 minutes.

7 Minutes Time Save Control

- To reduce the built up humidity inside the room.

Anti-Dew Formation Control

- Anti-Dew Formation Control for indoor unit discharge area.

Outdoor Unit

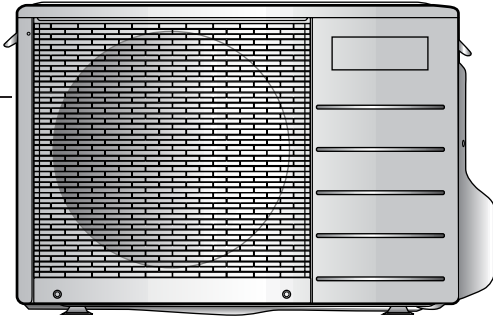

Compressor Reverse Rotation Protection Control

- To protect compressor from reverse rotation when there is an instantaneous power failure.

Overload Protector

- 2-Stage OLP to protect the compressor. Overload Protector will trip when
 - Temperature of compressor increases to 248°F.
 - High temperature or high current flows to compressor.
(Refer circuit diagram for OLP characteristic)

60 sec. Forced Operation Control

- Once the compressor is activated, it does not stop within the first 60 sec. However, it stops immediately when received stop signal from remote control.

Outdoor Fan Operation Control

3 Product Specifications

3.1. CS-C9DKU CU-C9DKU

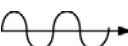
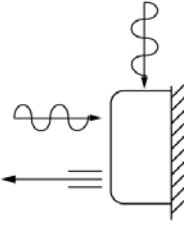
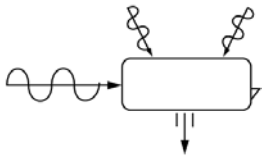

		Unit	Indoor unit	Outdoor unit	
Power Source (Phase, Voltage, Cycle)		ø, V, Hz	Single, 115, 60		
Cooling Capacity		kW (BTU/h)	2.58 (8,800)		
Moisture Removal		l/h (Pint/h)	1.0 (2.1)		
Airflow Method		OUTLET  INTAKE 	SIDE VIEW 	TOP VIEW 	
Air Volume	Lo	m ³ /min (cfm)	4.7 (164) - 4.7 (164)		
	Me	m ³ /min (cfm)	5.7 (202) - 5.7 (202)		
	Hi	m ³ /min (cfm)	7.2 (250) - 7.2 (250)		
	SHi	m ³ /min (cfm)	7.8 (274) - 7.8 (274)		
Noise Level		dB (A)	High 36 - 36, Low 26 - 26		
		Power level dB	High 49 - 39		
Electrical Data	Input Power	W	790		
	Running Current	A	7.2		
	EER	W/W (BTU/hW)	3.27 (11.10)		
	Starting Current	A	42.0		
Piping Connection Port (Flare piping)		inch	G ; Half Union 3/8"	G ; 3-way valve 3/8"	
		inch	L ; Half Union 1/4"	L ; 2-way valve 1/4"	
Pipe Size (Flare piping)		inch	G ; (gas side) 3/8"	G ; (gas side) 3/8"	
		inch	L ; (liquid side) 1/4"	L ; (liquid side) 1/4"	
Drain Hose	Inner diameter	inch (mm)	20/32 (16)		
	Length	inch (mm)	25-19/32 (650)		
Power Cord	Length	m	—		
	Number of core-wire		—		
Dimensions	Height	inch (mm)	11 - 1/32 (280)		
	Width	inch (mm)	31 - 15/32 (799)		
	Depth	inch (mm)	7 - 7/32 (183)		
Net Weight		lb (kg)	20 (9.0)		
Compressor	Description		—		
	Motor Type		—		
	Rated Output	W	—		
Fan Motor	Description		Cross-flow Fan	Propeller Fan	
	Material		ASG32K1	PP Resin	
	Type		Induction (4-poles)	Induction (6-poles)	
	Input		W	60.61	
	Rated Output		W	15	
	Fan Speed	Low	rpm	750 - 750	
		Medium	rpm	920 - 920	
		High	rpm	1,160 - 1,160	
SuperHigh		rpm	1,250 - 1,250		
Heat Exchanger	Description		Evaporator	Condenser	
	Tube material		Copper	Copper	
	Fin material		Aluminium (Pre Coat)	Aluminium (Blue Coat)	
	Fin Type		Slit Fin	Louver Fin	
	Row / Stage		(Plate fin configuration, forced draft)		
			2 × 15	1 × 20	
	FPI		21	16	
Size (W × H × L)		inch (mm)	24-1/32 × 12-13/32 × 1 (610 × 315 × 25.4)		
Refrigerant Control Device			—	Capillary Tube	
Refrigeration Oil		(cm ³)	—	SUNISO 4GDID or ATMOS M60 or ATMOS 56	
Refrigerant (R-22)		g (oz)	—	680 (24.0)	

		Unit	Indoor unit	Outdoor unit
Thermostat			Electrical	—
Protection Device			—	2 Stage Overload Protector
Capillary Tube	Length	inch (mm)	—	26-18/32 (675)
	Flow Rate	l/min	—	13.0
	Inner Diameter	inch (mm)	—	20/32 (1.6)
Air Filter	Material Style		P.P. Honeycomb	—
Capacity Control			Capillary Tube	
Compressor Capacitor		μF , VAC	—	35 μF , 370VAC
Fan Motor Capacitor		μF , VAC	5.0 μF , 230VAC	8.0 μF , 230VAC

Note:

- Specifications are subjected to change without prior notice for further improvement.

3.2. CS-C12DKU CU-C12DKU

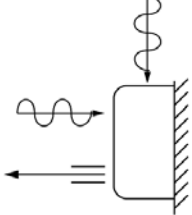
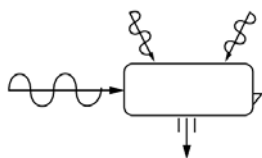
		Unit	Indoor unit	Outdoor unit	
Power Source (Phase, Voltage, Cycle)		ϕ , V, Hz	Single, 115, 60		
Cooling Capacity		kW (BTU/h)	3.60 (12,300)		
Moisture Removal		l/h (Pint/h)	1.6 (3.4)		
Airflow Method		<p>OUTLET</p>  <p>INTAKE</p> 	<p>SIDE VIEW</p> 	<p>TOP VIEW</p> 	
Air Volume	Lo	m ³ /min (cfm)	5.6 (199) - 5.6 (199)	—	
	Me	m ³ /min (cfm)	6.8 (238) - 6.8 (238)	—	
	Hi	m ³ /min (cfm)	8.0 (280) - 8.0 (280)	31.1(1,100)	
	SHi	m ³ /min (cfm)	8.2 (289) - 8.2 (289)	—	
Noise Level		dB (A)	High 39 - 39, Low 29 - 29	High 49	
		Power level dB	High 52 - 42	High 62	
Electrical Data	Input Power	kW	1.16		
	Running Current	A	10.3		
	EER	W/W (BTU/hW)	3.10 (10.60)		
	Starting Current	A	57.0		
Piping Connection Port (Flare piping)		inch inch	G ; Half Union 1/2" L ; Half Union 1/4"	G ; 3-way valve 1/2" L ; 2-way valve 1/4"	
Pipe Size (Flare piping)		inch inch	G ; (gas side) 1/2" L ; (liquid side) 1/4"	G ; (gas side) 1/2" L ; (liquid side) 1/4"	
Drain Hose	Inner diameter	inch (mm)	20 / 32 (16)	—	
	Length	inch (mm)	25-19/32 (650)	—	
Power Cord	Length	m	—	—	
	Number of core-wire		—	—	
Dimensions	Height	inch (mm)	11 - 1/32 (280)	21 - 1/4 (540)	
	Width	inch (mm)	31 - 15/32 (799)	30 - 23/32 (780)	
	Depth	inch (mm)	7 - 7/32 (183)	11 - 3/8 (289)	
Net Weight		lb (kg)	20 (9.0)	73 (33)	
Compressor	Description		—	Rotary (1 cylinder) rolling piston type	
	Motor Type		—	Induction (2-poles)	
	Rated Output	W	—	850	
Fan Motor	Description		Cross-flow Fan	Propeller Fan	
	Material		ASG32K1	PP Resin	
	Motor Type		Induction (4-poles)	Induction (6-poles)	
	Input	W	60.61	66.0 - 75.0	
	Rated Output	W	15	31	
	Fan Speed	Low	rpm	900 - 900	—
		Medium	rpm	1,080 - 1,080	—
High		rpm	1,280 - 1,280	820 - 820	
SuperHigh		rpm	1,310 - 1,310	—	
Heat Exchanger	Description		Evaporator	Condenser	
	Tube material		Copper	Copper	
	Fin material		Aluminium (Pre Coat)	Aluminium (Blue Coat)	
	Fin Type		Slit Fin	Louver Fin	
	Row / Stage		(Plate fin configuration, forced draft)		
			2 × 15	2 × 24	
	FPI		21	16	
Size (W × H × L)	inch (mm)	24-1/32 × 12-13/32 × 1 (610 × 315 × 25.4)	29-10/32; 28-15/32 × 19-27/32 × 1 744.2; 723.5 × 504 × 25.4		
Refrigerant Control Device			—	Capillary Tube	
Refrigeration Oil		(cm ³)	—	ATMOS M60 or SUNISO 4GDID or ATMOS M56	
Refrigerant (R-22)		g (oz)	—	760 (26.8)	
Thermostat			Electrical	—	
Protection Device			—	2 Stage Overload Protector	

		Unit	Indoor unit	Outdoor unit
Capillary Tube	Length	inch (mm)	—	16-23/32 (425)
	Flow Rate	l/min	—	18.0
	Inner Diameter	inch (mm)	—	2/32 (1.7)
Air Filter	Material Style		P.P. Honeycomb	—
Capacity Control			Capillary Tube	
Compressor Capacitor		μF , VAC	—	50 μF , 370VAC
Fan Motor Capacitor		μF , VAC	5.0 μF , 230VAC	8.0 μF , 230VAC

Note:

- Specifications are subjected to change without prior notice for further improvement.

4 Dimensions

4.1. Indoor Unit & Remote Control

CS-C9DKU
CS-C12DKU

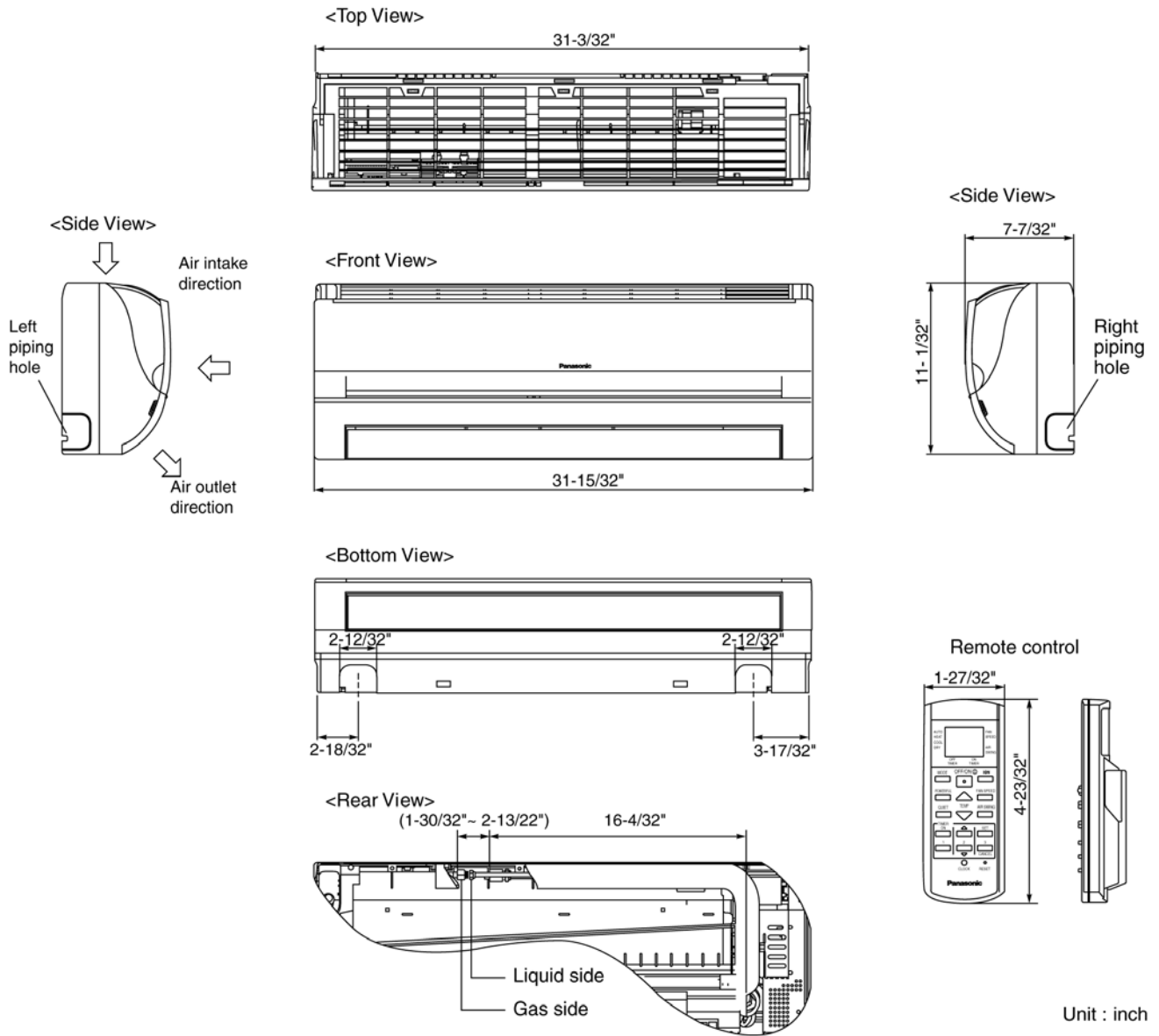

Relative position between the indoor unit and the installation plate <Front View>

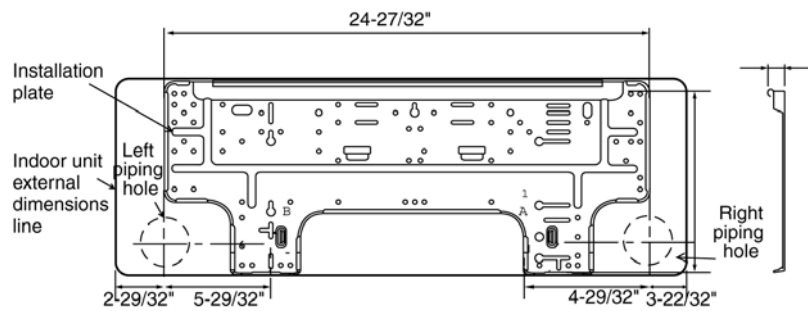

4.2. Outdoor Unit

CU-C9DKU

CU-C12DKU

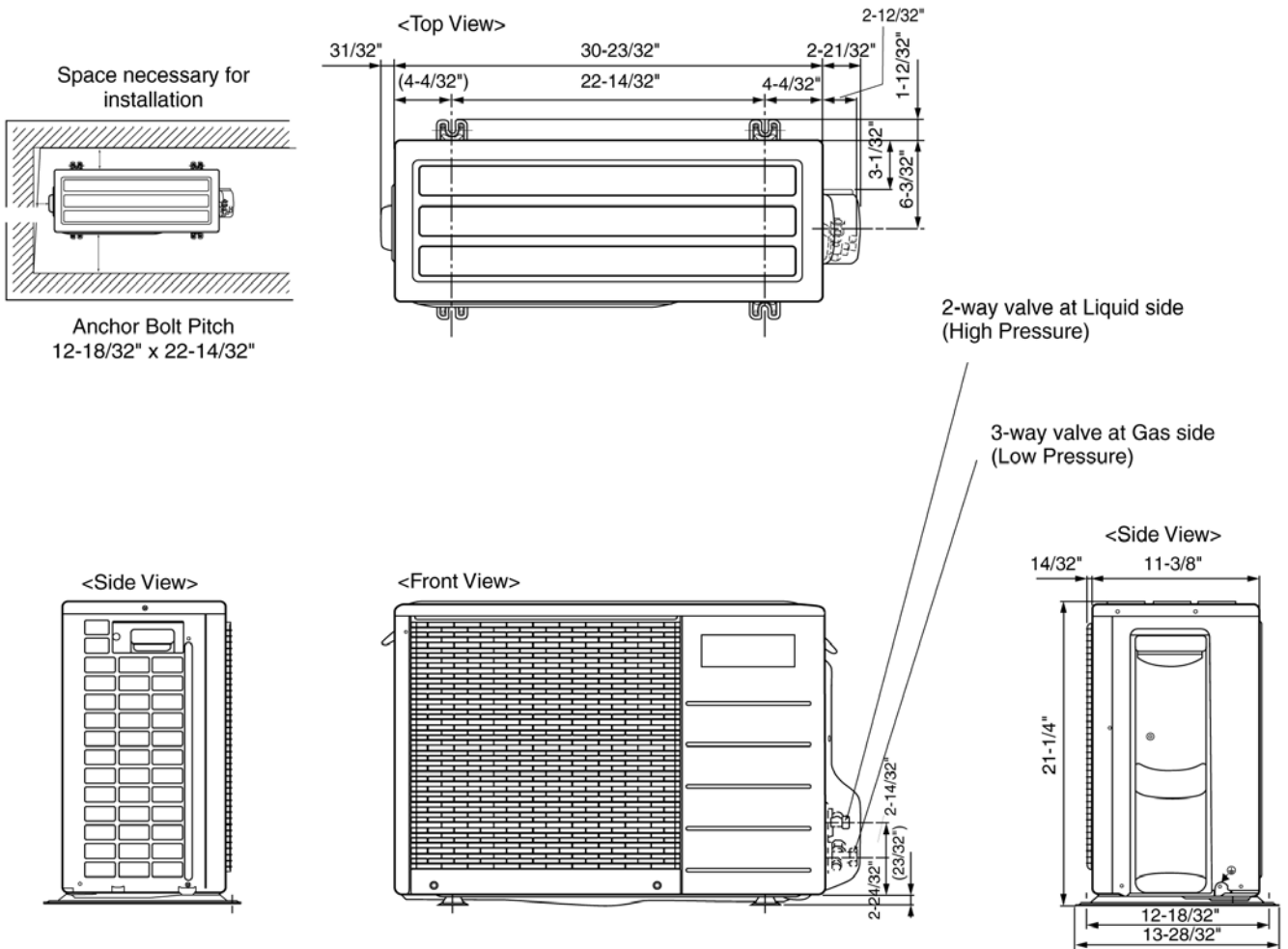

5 Refrigeration Cycle Diagram

CS-C9DKU CU-C9DKU

CS-C12DKU CU-C12DKU

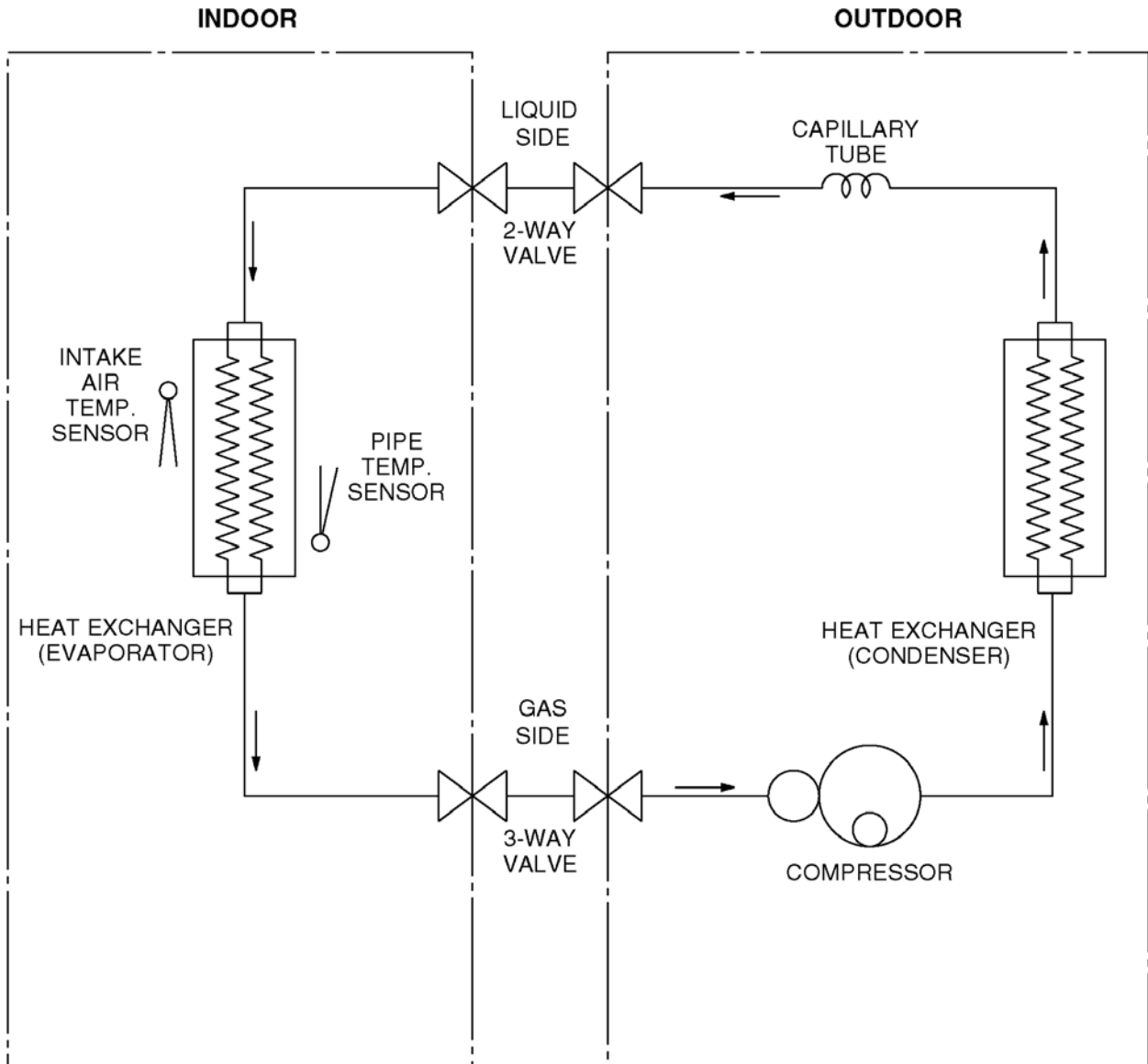

6 Block Diagram

CS-C9DKU CU-C9DKU
 CS-C12DKU CU-C12DKU

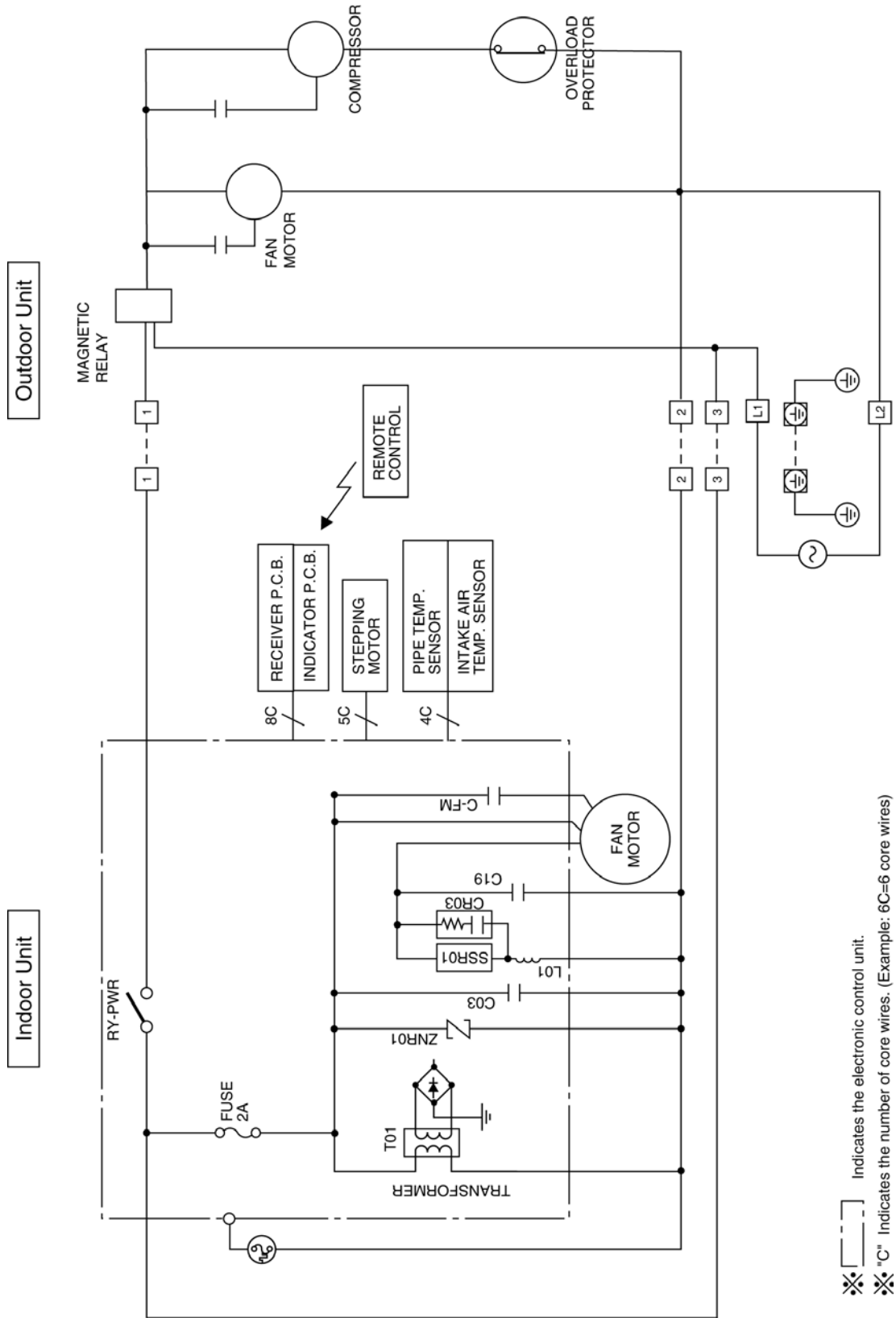

7 Wiring Diagram

CS-C9DKU CU-C9DKU
 CS-C12DKU CU-C12DKU

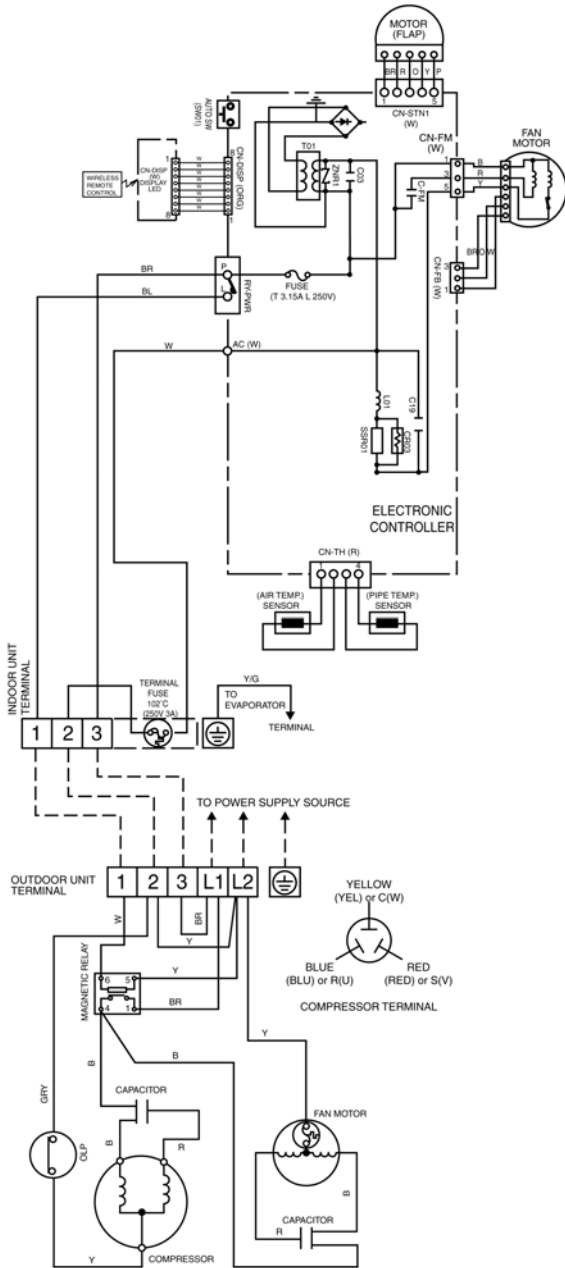

REMARKS

- B : BLUE
- BR : BROWN
- BL : BLACK
- GRY : GRAY
- O : ORANGE
- P : PINK
- R : RED
- W : WHITE
- Y/G : YELLOW/GREEN

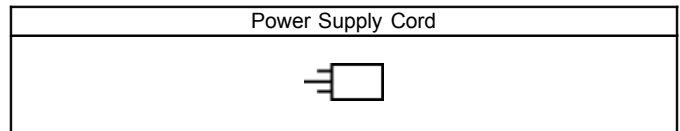

Resistance of Indoor Fan Motor Windings

MODEL	CS-C9DKU CS-C12DKU
CONNECTION	CWA921143
BLUE-YELLOW	82.4 Ω
YELLOW-RED	103.4 Ω

Note: Resistance at 68°F of ambient temperature.

Resistance of Outdoor Fan Motor Windings

MODEL	CU-C9DKU CU-C12DKU
CONNECTION	CWA951244
BLUE-YELLOW	61.2 Ω
YELLOW-RED	53.4 Ω

Note: Resistance at 78.8°F of ambient temperature.

Resistance of Compressor Windings

MODEL	CU-C9DKU	CU-C12DKU
CONNECTION	2R135126A	2P19S126C-1A
C - R	0.938 Ω	0.613 Ω
C - S	2.611 Ω	2.106 Ω

Note: Resistance at 77°F/68°F of ambient temperature.

8 Operation Details

8.1. Cooling Operation

- Cooling operation can be set using remote control.
- This operation is applied to cool down the room temperature reaches the setting temperature set on the remote control.
- The remote control setting temperature, which takes the reading of intake air temperature sensor, can be adjusted from 60.8°F to 86°F.
- During cooling operation, the compressor will stop running and restart as shown in below figure.

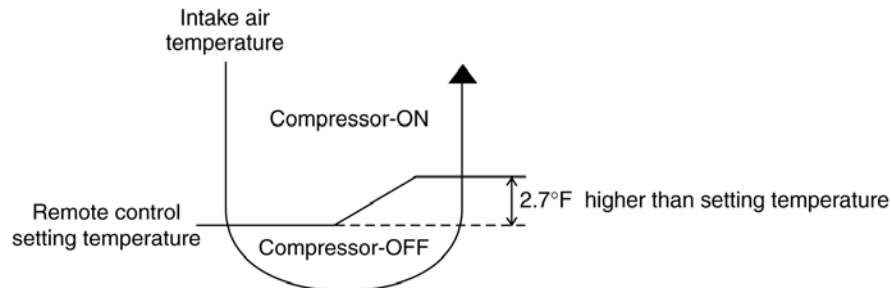

8.1.1. Cooling Operation Time Diagram

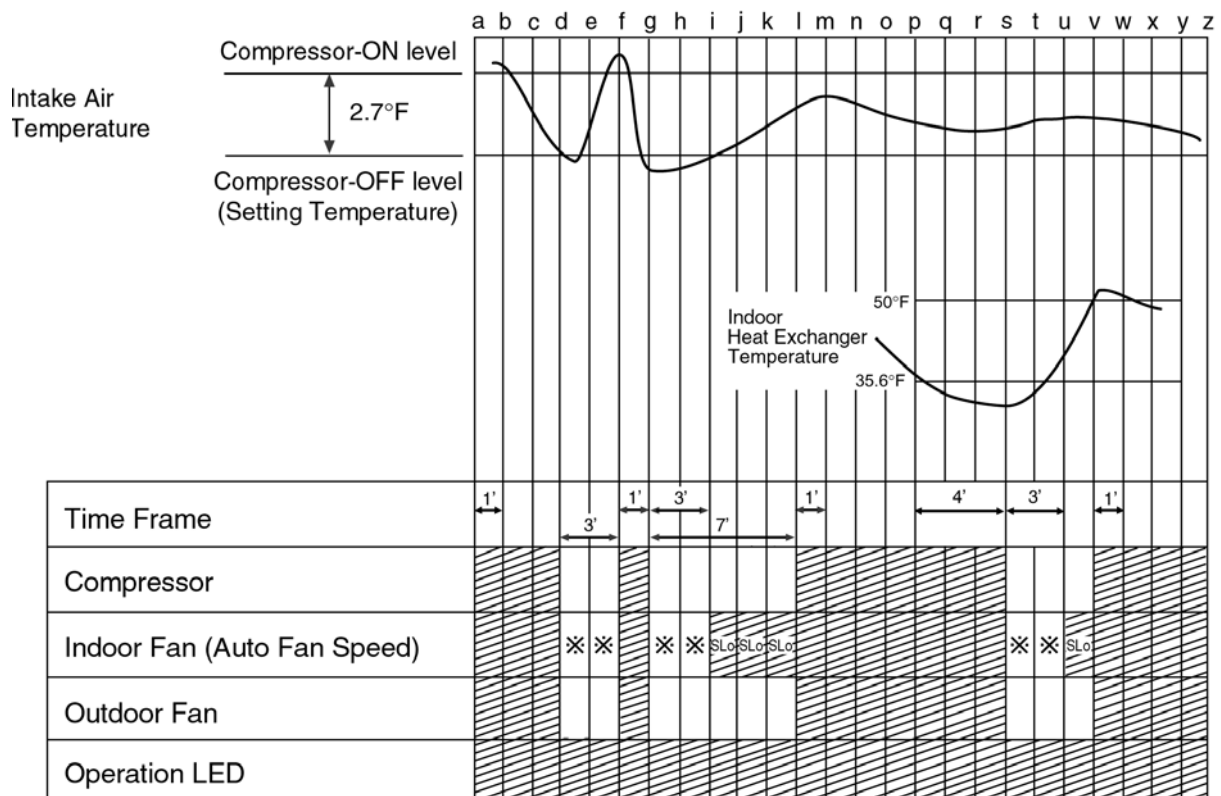

<Description of operation>

a – b, f – g, l – m, v – w : Minimum 60 seconds forced operation

d – f, g – i, s – u : Minimum 3 minutes restart control (Time Delay Safety Control)

g – l : Maximum 7 minutes time save control

p – v : Anti-Freezing Control

Operation

Stop

(⊗) d – f, g – i, s – u : Indoor fan rotates at SLo for 20 seconds and off for 160 seconds.

8.2. Soft Dry Operation

- Soft Dry operation can be set using remote control.
- Soft Dry operation is applied to dehumidify and to perform a gentle cooling to the room.
- This operation starts when the intake air temperature sensor reaches the setting temperature on the remote control.
- When operation begins, Soft Dry will be switched “ON” for a maximum 10 minutes, then Soft Dry operation will be turned “OFF” for a minimum 6 minutes. After that, the Soft Dry operation will be “ON” and “OFF” based on the setting temperature as shown in below figure.
- However after 3 minutes of compressor off, during Soft Dry “OFF” (within 6 minutes Soft Dry restart control), the indoor unit will start to operate at normal Cooling mode if the intake temperature is higher than Cooling “ON” point.

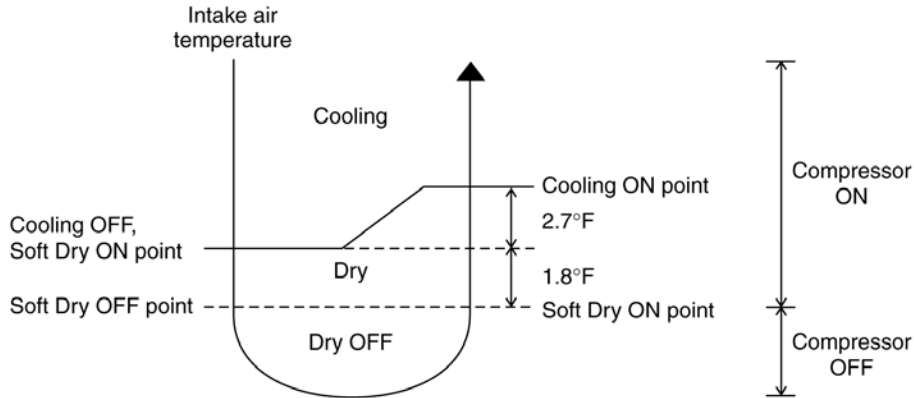

8.2.1. Soft Dry Operation Time Diagram

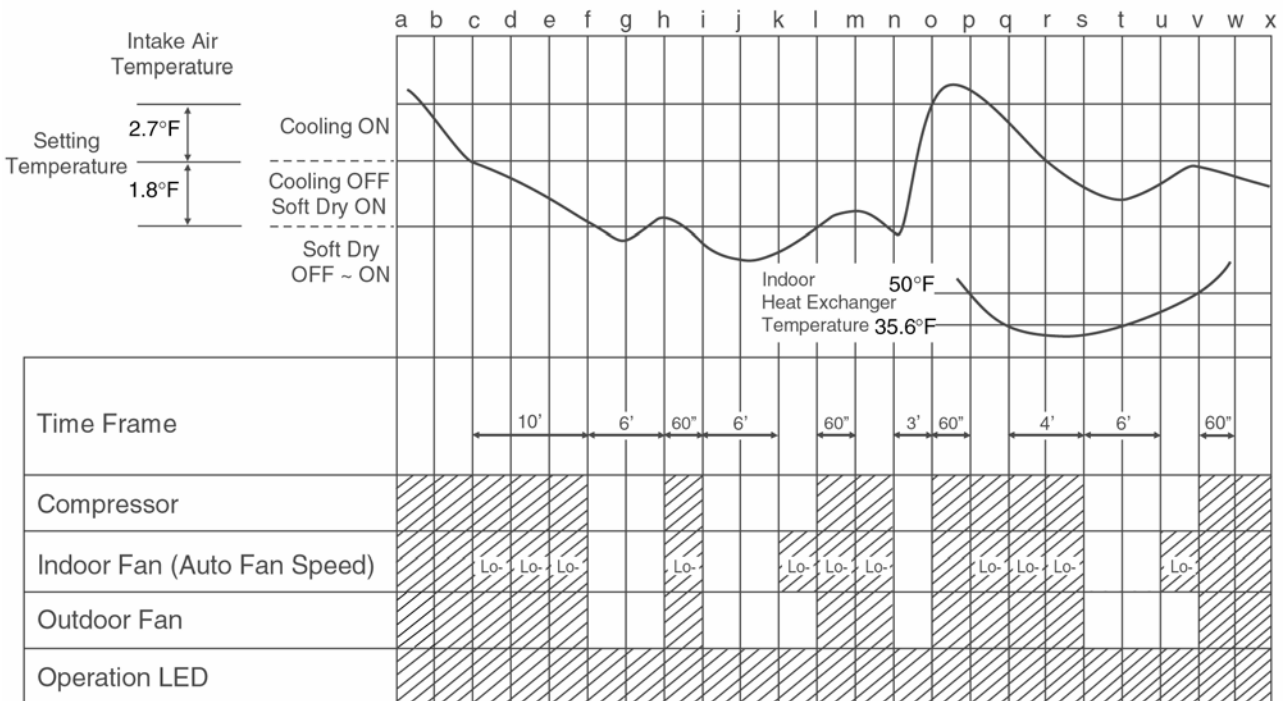

<Description of operation>

- h - i, l - m, o - p, v - w : Minimum 60 seconds **forced operation**
- n - o : Minimum 3 minutes restart control (Time Delay Safety Control) - Cooling operation
- f - h, i - k, s - u : Minimum 6 minutes restart control (Time Delay Safety Control) - Soft dry operation
- q - v : Anti-Freezing Control

 Operation
 Stop

8.3. Automatic Operation

- Automatic operation can be set using remote control.
- This operation starts to operate with indoor fan at SLo speed for 20 seconds to judge the intake air temperature.
- After judged the temperature, the operation mode is determined by referring to the below standard.

Intake Air Temperature	73.4°F	↑ Cooling Operation ↓ Soft Dry Operation
---------------------------	--------	---

- Then, the unit start to operate at determined operation mode, until it is switched off using remote control, with the setting temperature as shown in below table.

	Setting Temperature (Standard)
Cooling Operation	77°F
Soft Dry Operation	71.6°F

- The setting temperature for all the operations can be changed one level up or one level down from the standard temperature as shown in below table by pressing on the temperature up or temperature down button at remote control.

		Cooling	Soft Dry
Higher	→ +3.6°F	80.6°F	75.2°F
Standard	→ 0°F	77°F	71.6°F
Lower	→ -3.6°F	73.4°F	68°F

- The operation mode judging temperature and standard setting temperature can be increased by 3.6°F permanently, by open the circuit of JX1 at indoor electronic controller.

Intake Air Temperature	77°F	↑ Cooling Operation ↓ Soft Dry Operation
---------------------------	------	---

	Setting Temperature (Standard)
Cooling Operation	80.6°F
Soft Dry Operation	75.2°F

8.4. Operation Control

8.4.1. Restart Control (Time Delay Safety Control)

- When the thermo-off temperature (temperature which compressor stops to operate) is reached during:-
 - Cooling/Heating operation - the compressor stops for 3 minutes (minimum) before resume operation.
 - Soft Dry operation - the compressor stops for 6 minutes (minimum) before resume operation.
- If the operation is stopped by the remote control, the compressor will not turn on within 3 minutes from the moment operation stop, although the unit is turn on again within the period.
- This phenomenon is to balance the pressure inside the refrigerant cycle.

8.4.2. 7 Minutes Time Save Control

- The compressor will start automatically if it has stopped for 7 minutes and the intake air temperature falls between the compressor ON temperature (A) and compressor OFF temperature (B) during the period.
- This phenomenon is to reduce the built up humidity inside a room.

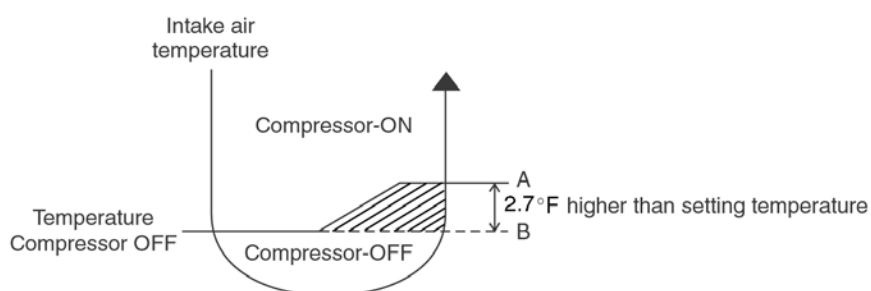

8.4.3. 60 Seconds Forced Operation

- Once the air conditioner is turned on, the compressor will not stop within 60 seconds in a normal operation although the intake air temperature has reached the thermo-off temperature. However, force stop by pressing the OFF/ON operation button at the remote control is permitted.
- The reason for the compressor to force operate at minimum 60 seconds is to allow the refrigerant oil run in a full cycle and return back to the outdoor unit.

8.4.4. Starting Current Control

- When the compressor, outdoor fan motor and indoor fan motor are simultaneously started, the indoor fan motor will start to operate at 1.6 second later.
- The reason of the difference is to reduce the starting current flow.

8.4.5. Anti-Freezing Control

- If the temperature of the indoor heat exchanger falls below 35.6°F continuously for 4 minutes or more, the compressor turns off. The fan speed setting remains the same.
- This phenomenon is to protect the indoor heat exchanger from freezing and to prevent higher volume of refrigerant in liquid form returning to the compressor.
- Compressor will restart again when the indoor heat exchanger temperature rises to 50°F (Recovery).
- Restart control (Time Delay Safety Control) will be applied in this Control if the recovery time is too short.

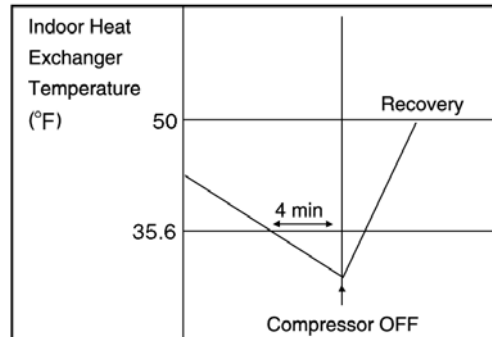

8.4.6. Compressor Reverse Rotation Protection Control

- If the compressor is operating continuously for 5 minutes or longer and the temperature difference between intake air and indoor heat exchanger is 4.5°F or less for continuous 2 minutes, compressor will stop and restart automatically.
- Time Delay Safety Control is activated before the compressor restart.

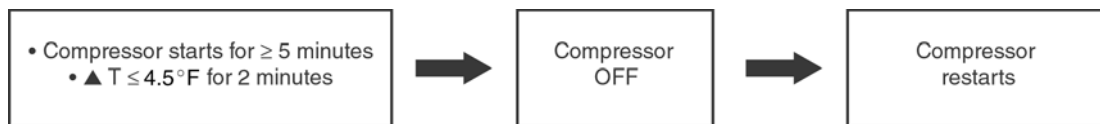

$s T = \text{Intake air temperature} - \text{Indoor heat exchanger temperature}$

- This is to prevent compressor from rotate reversely when there is an instantaneous power failure.

8.4.7. Anti-Dew Formation Control

- Purpose is to prevent dew formation on indoor unit discharge area.
- When room temperature is constant ($\pm 1.8^\circ\text{F}$) the following condition occur for 30 minutes continuously, anti-dew formation will activate:
 - Indoor intake temperature is more than 75.2°F and less than 86°F.
 - Remote Control setting temperature is less than 77°F
 - Compressor is on.
 - Cooling Operation Mode.
 - Indoor fan motor operate at Low fan speed or QLo.

- Anti-Dew Formation is control by:-
- Increasing Air Flow Volume

1. Lo fan speed.

Lo fan speed is changed to Lo+ after 30 min to prevent dew formation.

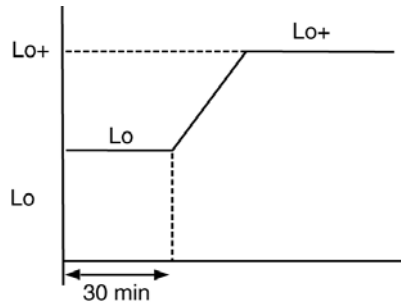

2. QLo fan speed.

Dew formation may occur at QLo cool, therefore QLo cool is operated only 1hr 30min (1 hr QLo, 30 min QLo + 80 rpm). After that, it operates at QLo + 160 rpm (However Quiet LED remains on).

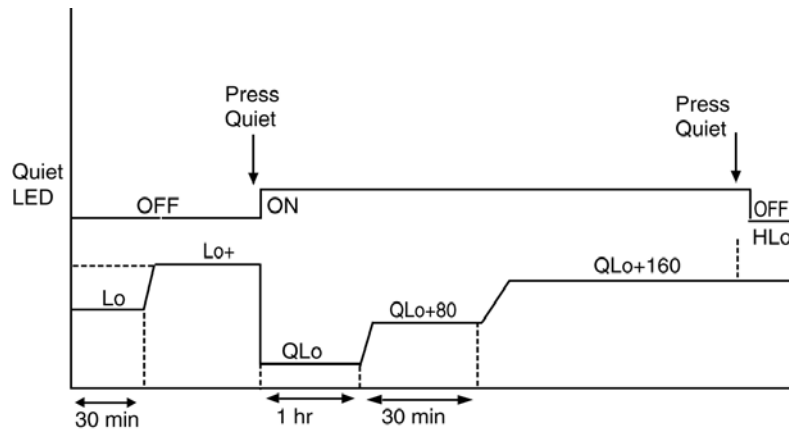

- Narrowing

1. Vertical Airflow Direction

During Anti-Dew condensation prevention, Airflow Direction Auto-control angle from 0° - 32° to 20° - 30° under cooling and Soft Dry operation mode.

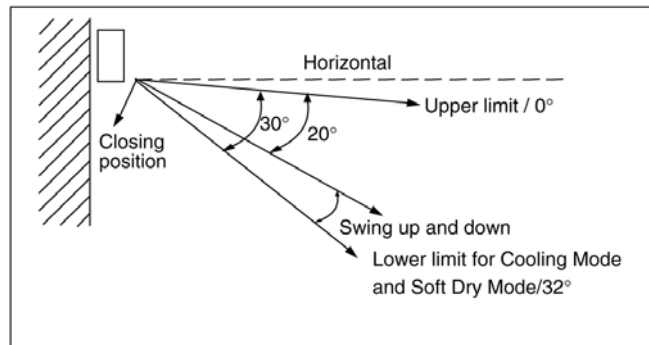

During Anti-Dew condensation prevention, Airflow Direction Manual Control angle change from 10°, 15°, 20°, 26°, 32° to 22°, 24°, 26°, 28°, 30°.

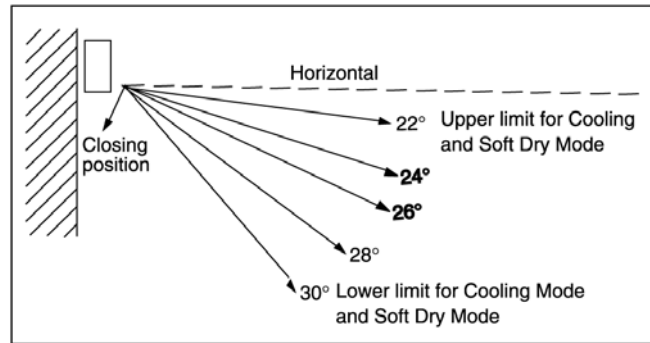

8.5. Indoor Fan Speed Control

- Indoor Fan Speed can be set using remote control.

8.5.1. Fan Speed Rotation Chart

Speed	Fan Speed (rpm)	
	CS-C9DKU	CS-C12DKU
S Hi	1250	1310
Hi	1160	1280
Me	920	1080
H Lo	840	960
C Lo	750	900
Lo-	750	850
S Lo	710	820
SS Lo	-	-
Q S Hi	-	-
Q Hi	1060	1180
Q Me	820	980
QH Lo	-	-
Q Lo	650	800

8.5.2. Automatic Fan Speed Control

- When set to Auto Fan Speed, the fan speed is adjusted between maximum and minimum setting as shown in the table.
 - Fan speed rotates in the range of Hi and Me.
 - Deodorizing Control will be activated.

Speed Mode			S Hi	Hi	Me	H Lo	C Lo	Lo-	S Lo	SSLo	Stop
Cooling	Normal	Manual	Hi	○							
			Me		○						
			Lo				○				
	Auto			○	○			○			○
	Powerful	Manual	○								
		Auto	○								
Economy	Manual						○				
	Auto						○				
Soft Dry	Manual							○			○
	Auto							○			○
Mode judgement									○		
Cooling	Quiet	Manual	Q Hi		Hi-100						
			Q Me			Me-100					
			Q Lo					CLo-100			
		Auto			Hi-100	Me-100			○		
Soft Dry	Quiet	Manual						○			○
		Auto						○			○

- Auto Fan Speed during cooling operation:
 1. Indoor fan will rotate alternately between off and on as shown in below diagram.
 2. At the beginning of each compressor start operation, indoor fan will increase fan speed gradually for deodorizing purpose.
 3. For the first time the compressor operate, indoor fan will be switched to Hi fan speed from Lo- after 70 seconds from the start of compressor. This cause the room temperature to achieve the setting temperature quickly.
 4. During compressor stop, indoor fan will operate at Lo for the beginning 20 seconds to prevent higher volume of refrigerant in liquid form returning to the compressor.
 5. After the compressor at turn off condition for 3 minutes, indoor fan will start to operate at Lo- to circulate the air in the room. This is to obtain the actual reading of the intake air temperature.
 6. For the resume of compressor operation, indoor fan will operate at Me fan speed to provide comfort and lesser noise environment, after 70 seconds from the restart of compressor.

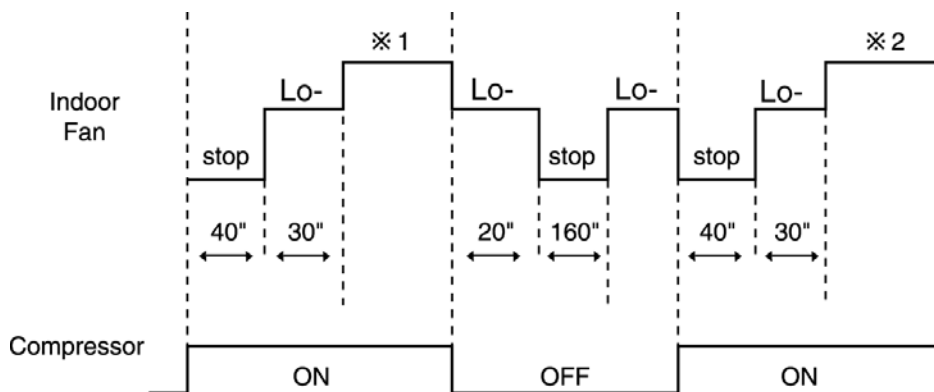

- ※ 1 Fan Speed is Hi until the compressor stops (when the room temperature reaches setting temperature).
- ※ 2 Fan Speed is Me after the compressor restarts.

- Auto Fan Speed during Soft Dry operation:

1. Indoor fan will rotate alternately between off and Lo-.
2. At the beginning of each compressor start operation, indoor fan will increase fan speed gradually for deodorizing purpose.
3. When compressor at turn off condition for 6 minutes, indoor fan will start fan speed at Lo- to circulate the air in the room. This is to obtain the actual reading of intake air temperature.

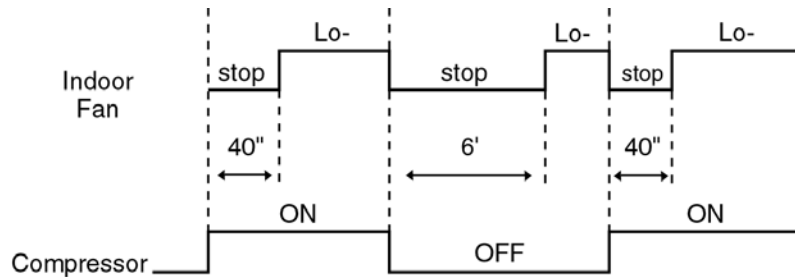

8.5.3. Manual Fan Speed Control

- Manual fan speed adjustment can be carried out by using the Fan Speed selection button at the remote control.
- There are 3 types of fan speed settings: Lo, Me, Hi.

8.6. Outdoor Fan Speed Control

- There is only one speed for outdoor fan motor.
- When the air conditioner is turned on, the compressor and the outdoor fan will operate simultaneously.
- Likewise, both compressor and outdoor fan will stop at the same time if the unit is turned off.

8.7. Vertical Airflow Direction Control

8.7.1. Auto Control

- When the vertical airflow direction is set to Auto using the remote control, the louver swings up and down as shown in the diagram.
- When stop operation using the remote control, the discharge vent is reset, and stop at the closing position.
- During Cooling operation or Soft Dry operation, indoor fan motor may stop to rotate at certain periods. At that condition, the louver will stop swinging and rest at the upper limit.

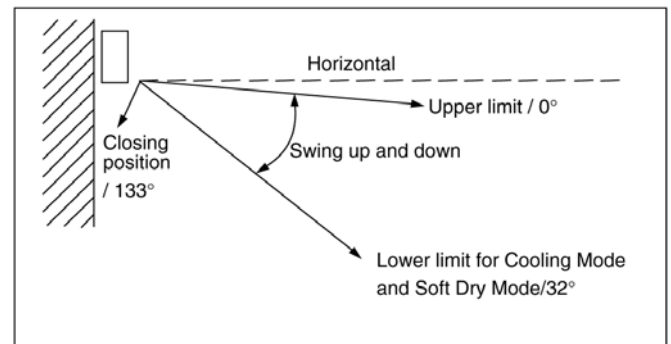

8.7.2. Manual Control

- When the vertical airflow direction is set to Manual using the remote control, the automatic airflow is released and the airflow direction louver move up and down in the range shown in the diagram.
- The louver can be adjusted by pressing the button to the desired louver position.
- When stop operation using the remote control, the discharge vent is reset, and stop at the closing position.

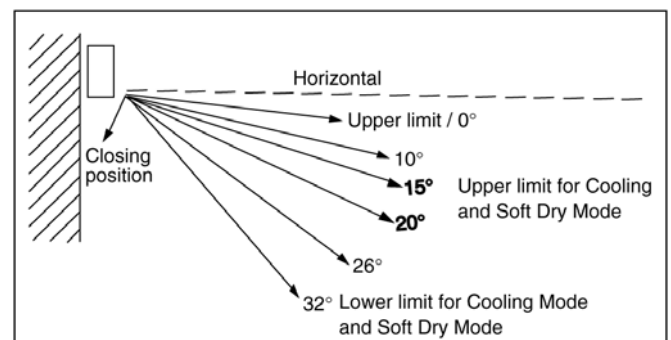

8.8. Horizontal Airflow Direction Control

- The horizontal airflow direction louvers can be adjusted manually by hand.

8.9. Powerful Operation

- The Powerful operation is to achieve the setting temperature quickly.
- When Powerful operation is set, the setting temperature will be automatically decreased 5.4°F internally against the present setting temperature (Lower temperature limit: 60.8°F).
- This operation automatically will be running under SHi Fan Speed (Cooling), Lo- Fan Speed (Soft Dry).
- Vertical Airflow Direction:-
 - In "Manual" setting, the vane will automatically shift down 10° lower than previous.
 - In "Auto" setting, the vane will automatically swing up and down. However the lower limit will be shifted 10° downward.
- Powerful Mode will operate for 15 minutes only and operation will shift back to previous setting mode.
- Powerful operation stops when:-
 - Powerful mode button is pressed again.
 - Stopped by OFF/ON operation button.
 - Timer OFF activates.
 - Quiet mode button is pressed.
 - Operation mode button is changed.
 - Economy mode button is pressed.

8.10. Quiet Operation

(For Cooling Operation or cooling region of Soft Dry Operation)

- The Quiet operation is to provide quiet/cooling operation condition compare to normal operation.
- Once the Quiet Mode is set at the remote control, the Quiet Mode LED illuminated. The sound level will reduce around 2 dB for Lo fan speed or 3 dB for Hi/Me fan speed against the present operation sound level.
- Dew formation become severe at Quiet Lo cool, therefore Quiet Lo cool is operated only 1hr 30 min (1hr QLo, 30 min QLo + 80 rpm). After that, it goes back to Lo cool (However Quiet LED remains on).
- Manual Airflow Direction:-
 - RPM control during Lo cool

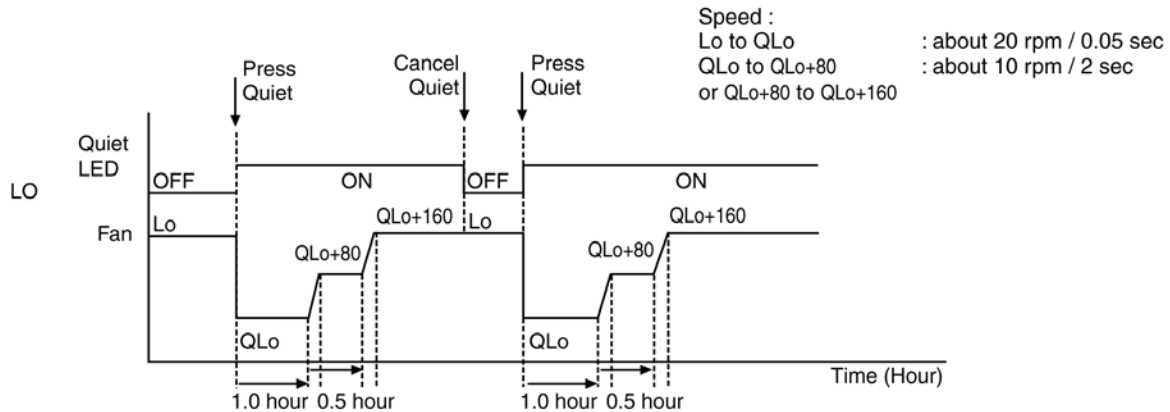

- RPM control during Hi cool

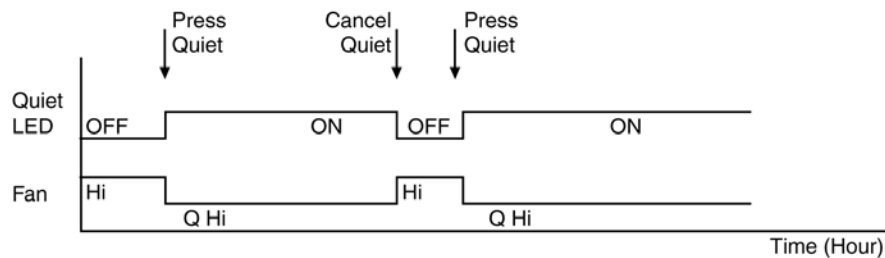

- Auto Airflow Direction:-

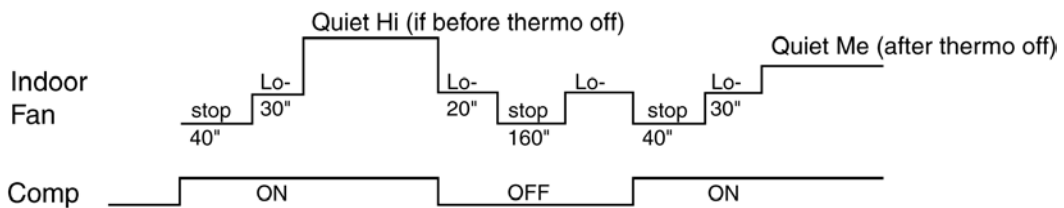

- Quiet operation stops when:-
 - Quiet button is pressed again.
 - Stopped by OFF/ON operation button.
 - Timer OFF activates.
 - Powerful button is pressed.
 - Economy button is pressed.
 - Operation mode button is changed.

8.11. Timer Control

- There are 2 types of timer, ON and OFF timer.
- Both ON and OFF timer can be set by pressing ON or OFF button respectively.
- By pressing ON/OFF operation button, ON Timer or OFF Timer will not be cancelled.
- To cancel the previous timer setting, press CANCEL button.
- To activate the previous timer setting, press SET button once again.
- If main power supply is switched off, the timer setting will be cancelled.

8.11.1. ON Timer

- When ON Timer is set by using the remote control, the unit will start to operate slightly before the set time, so that the room will reach nearly to the set temperature by the set time.
- For Cooling and Soft Dry operation, the operation will start 15 minutes before the set time.
- For Automatic operation, the indoor fan will operate at SLo speed for 25 seconds, 30 minutes before the set time to detect the intake air temperature to determine the operation mode. The operation indication lamp will blink at this time.

8.11.2. OFF Timer

- When OFF Timer is set by using the remote control, the unit will stop operate according to the desired setting.

8.12. Random Auto Restart Control

- If there is a power failure during operation, the air conditioner will automatically restart after 3 to 4 minutes when the power is resumed.
- It will start with previous operation mode and airflow direction.
- If there are more than one air conditioner unit in operation and power failure occur, restart time for each unit to operate will be decided randomly using 4 parameters:- intake air temperature, setting temperature, fan speed and air swing louver position.
- This Random Auto Restart Control is not available when Timer is set.
- This control can be omitted by open the circuit of JX2. (Refer Circuit Diagram)(Indoor PCB)

8.13. Remote Control Signal Receiving Sound

- Long beep sound will be heard when:-
 - Stopping the air conditioner using ON/OFF switch.
 - Stopping the Quiet Mode.
 - Stopping the Powerful Mode.
- Short beep sound will be heard for others setting.

8.14. Economy Mode Operation

- Purpose of this operation is to save or reduced electrical power consumption of the room air conditioner.
However consumer is advised to use Economy Mode operation after the room temperature reaches the desired temperature.

1. Cooling and Soft Dry Mode

- When the Economy Mode is set, the set temperature will be automatically increased 0.9°F against the present setting temperature. This operation automatically will be running under SLo Fan speed.
- Vertical Airflow Direction:-
In "Manual" or "Auto" setting, the vane will automatically change to Auto Air Swing.

2. Economy Mode will stop if:

- Economy mode button is pressed again.
- Stopped by ON / OFF switch.
- Timer-off activates.
- Powerful mode button is pressed.
- Fan Speed control button is pressed.
- Operating mode is changed.
- Air Swing condition is changed.
- Quiet button is pressed ON.

9 Operating Instructions

■ Important notice

To prevent personal injury, injury to others and property damage, the following instructions must be followed.

Incorrect operation due to failure to follow instructions will cause harm or damage, the seriousness of which is classified as below:



Warning

This sign warns of death or serious injury.



Caution

This sign warns of injury or damage to property.

The instructions to be followed are classified by the following symbols:



This symbol denotes an action that is PROHIBITED.



These symbols denote actions that are COMPULSORY.

Thank you for purchasing a Panasonic Air Conditioner

SAFETY PRECAUTIONS

Installation Precautions



Warning

Do not install, remove or reinstall the unit by yourself.

- Improper installation will cause leakage, electric shock or fire. Please consult an authorized dealer or specialist for the installation work.



Caution



- This air conditioner must be grounded. Improper grounding will cause electric shock.
- Ensure that the drainage piping is connected properly. Otherwise, water will leak.
- Current leakage protection equipment must be installed. Otherwise, electric shock or fire may occur.



- Do not install the unit in a potentially explosive environment.

Operation Precautions



Warning



- Do not share power outlet.
- Do not modify power cord.
- Do not use an extension cord.
- Do not operate with wet hands.
- Do not insert fingers or other objects into the indoor or outdoor unit.
- Do not attempt to repair the unit by yourself.
- Do not use rechargeable (Ni-Cd) batteries.
- Keep the remote control away from infants and small children to prevent them from accidentally swallowing the batteries.



- Use specified supply cord.
- If the supply cord is damaged or needs replacement, it must be replaced by the manufacturer or its service agent or a similarly qualified person in order to avoid a hazard.

- Remove the batteries if the unit is not going to be used for a long period of time.
- New batteries of the same type must be inserted following the polarity stated to prevent malfunction of the remote control.



- In case of emergency or if an abnormal condition (burnt smell, etc) occurs, turn off the power supply.



Caution



- Do not wash the unit with water, benzene, thinner or scouring powder.
- Do not use for other purposes such as preservation of food.
- Do not store or use any combustible equipment in the airflow direction.
- Do not sit on or place anything on the indoor or outdoor unit.
- Do not expose directly to cold air for a long period.



- Ventilate the room regularly.
- Pay attention as to whether the installation rack is damaged after a long period of usage.



- Switch off the power supply before cleaning or servicing.
- Turn off the power supply if the unit is not going to be used for a long period of time.

Safety Regulation

The appliance is not intended for use by young children or infirm people without supervision. Young children should be supervised to ensure that they do not play with the appliance.

Power Supply	
Time Delay Fuse	Rated Volts
15 Amps CS-C9DKU/CU-C9DKU	115V
25 Amps CS-C12DKU/CU-C12DKU	

Operation Condition (°F)

Use this air conditioner under the following temperature range.

DBT: Dry Bulb Temperature WBT: Wet Bulb Temperature	Indoor		Outdoor	
	DBT	WBT	DBT	WBT
Maximum Temperature	89.6	73.4	109.4	78.8
Minimum Temperature	60.8	51.8	60.8	51.8

Note: The illustrations in this manual are for explanation purposes only and may differ from the actual unit. It is subject to change without notice for future improvement.

PRODUCT OVERVIEW

Indoor Unit

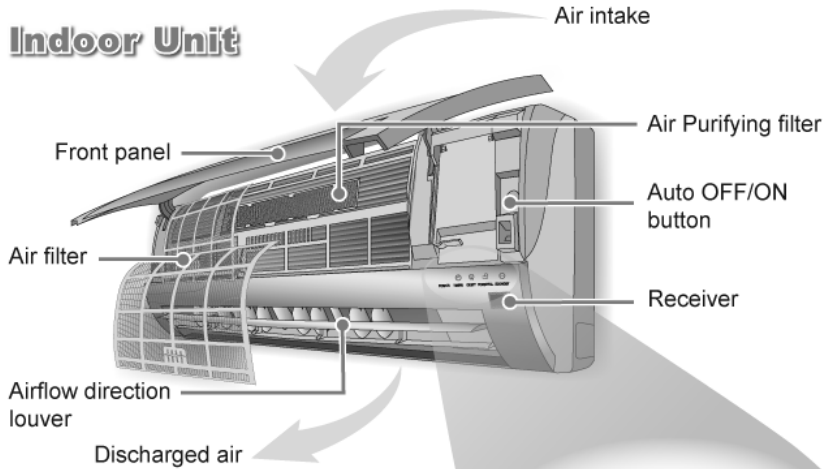

Outdoor Unit

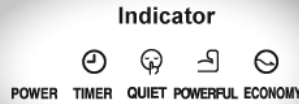
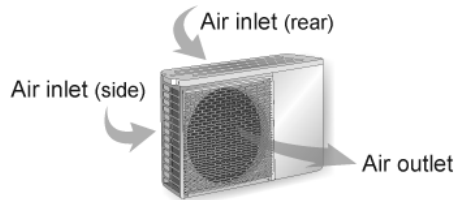

Remote Control

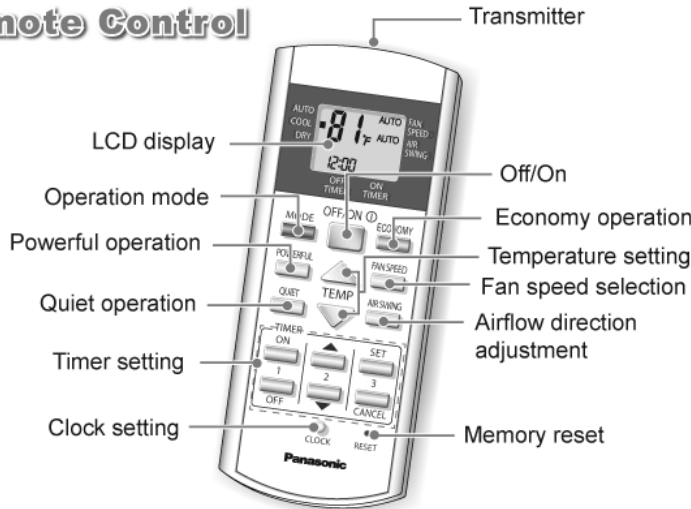

About

Remote Control Preparation

1. Pull out
2. Insert batteries (AAA or R03)
3. Press CLOCK button
4. Set current time
5. Press again to confirm

- Timer operation will be based on current time set.
- The batteries can be used for approximately 1 year.
- The batteries must be recycled or disposed of properly.

Remote Control Signal

- Make sure it is not obstructed.
- Maximum distances : 10m.
- Certain fluorescent lights may interfere with signal transmission. Consult your dealer.

Auto OFF/ON Button

- To operate the unit if the remote control is misplaced or malfunctioning.

Action	Operation mode
Press once	Automatic Operation
Press until "beep" sound	Cooling Operation

- To turn OFF, press the Auto OFF/ON button again.
- To switch the remote control signal receiving sound off or on.
 1. Press until you hear a "beep" sound and release.
 2. Press again until you hear a "beep-beep" sound and release.
 3. Press to switch the sound off or on. (Long "beep" - OFF; short "beep" - ON)

Troubleshooting

- | | |
|--|--|
| ● Operation delayed for a few minutes after restart. | ➢ This is a normal self protection function. |
| ● Sound like water flowing during operation. | ➢ Caused by refrigerant flow inside. |
| ● Mist emerges from indoor unit. | ➢ Condensation effect due to cooling process. |
| ● Noisy during operations. | ➢ Installation work could be slanted or front panel isn't closed properly. |
| ● Remote control/display does not work. | ➢ Check whether batteries are correctly inserted or need replacement. |
| ● The unit cannot operate. | ➢ Check whether circuit breaker is tripped or timer is being used correctly. |
| ● Outdoor unit emits water/steam. | ➢ Condensation or evaporation has occurred at piping surface. |

■ Operation Details

AUTO - Automatic Operation

- The unit will automatically select the operation mode according to the room temperature.
- Once the operation mode is selected, the unit will operate at the standard setting temperature as shown:

Room temperature	Operation mode	Standard setting temperature
73.4°F & above	Cool	77°F
Below 73.4°F	Dry	72°F

- You may press or button to change the standard setting temperature to "HI" or "LO" as shown:

Operation mode	HI	LO
Cool	81°F	73°F
Dry	75°F	68°F

COOL - Cooling Operation

- Enables you to enjoy the cooling effect at your preferred setting temperature.
- The range of temperature can be selected from 60°F ~ 86°F.

DRY - Soft Dry Operation

- Allows you to set the desired temperature at low fan speed which enables you to dehumidify your surroundings.
- The range of temperature can be selected from 60°F ~ 86°F.

HOW TO OPERATE

Auto, Cool, Dry

1 Start the operation.

2 Select the desired operation.

3 Set the temperature.

- Powerful, Quiet and Economy operations can be activated in all operation modes.
- Press button again to stop the operation.

Hint

- To save electricity, close the curtains when using air conditioner to prevent sunlight and heat from coming in.

Troubleshooting

- The room has a peculiar odour.
 - This may be a damp smell emitted by the wall, carpet, furniture or clothing in the room.
- Air conditioner does not cool efficiently.
 - Ensure the temperature has been set correctly.
 - Ensure windows and doors have been closed properly.
 - Ensure filters are cleaned or replaced when necessary.
 - Ensure inlet and outlet vents of the unit have not been obstructed.

HOW TO OPERATE

Powerful, Quiet, Economy, Fan Speed, Air Swing

POWERFUL

Enables powerful operation.

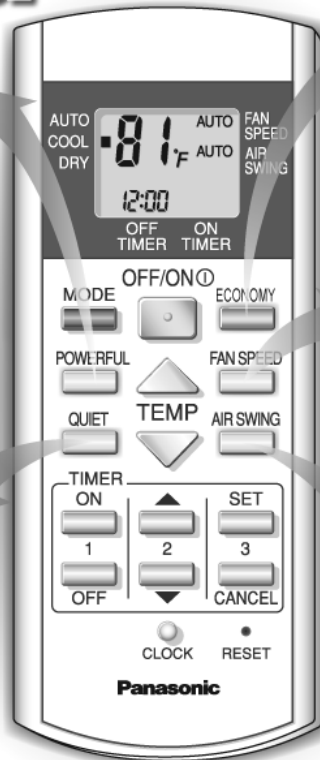

ECONOMY

Enables economy operation.

FAN SPEED

Select fan speed.



AIR SWING

Adjust the vertical airflow direction louver.



QUIET

Enables quiet operation.

- Powerful, Quiet or Economy operations cannot be activated at the same time.
- Powerful, Quiet or Economy operations can be cancelled by pressing the respective button again.

■ Operation Details

POWERFUL

- To achieve setting temperature quickly. It will operate for 15 minutes and return to the previous setting.

QUIET

- To provide a quiet environment.

ECONOMY

- To save electrical power consumption.
- Use when desired room temperature is reached.

FAN SPEED

- To provide you with various fan speed selections.

- There are 3 levels of fan speed in addition to automatic fan speed.
- Automatic fan speed:

The speed of the indoor fan is automatically adjusted according to the operation.

AIR SWING

- To ventilate air in the room.
- There are 5 settings in addition to automatic vertical airflow direction.
- If automatic vertical airflow direction has been set, the louver swings up and down automatically.
- Please do not adjust the vertical airflow direction louver manually.
- Horizontal airflow direction louver can be adjusted manually.

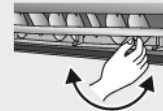

Hints



- If you wish to have the cool air blowing directly on you, set the airflow direction downward but not for an excessive length of time, as it may harm your health.
- Electricity use can be reduced by approximately 10% if you set the temperature 1°F higher than the desired temperature during cooling operation.

Troubleshooting



- Indoor fan stops occasionally during Automatic Fan Speed setting.
 - This is an advanced feature that helps to remove smell from the surrounding area during operation.

■ Operation Details

TIMER

- Use the ON timer to turn on the air conditioner at the desired time. This will give you a cooled environment, e.g. when you return from work or wake up.
- When the ON timer is set, operation will start 15 minutes before the actual set time.
- Use the OFF timer to stop air conditioner operation at the desired time. This can save electricity while you are going out or sleeping.
- The set timer will repeat daily once it is set.
- If there is a power failure, you can press the SET button to restore the previous setting once the power resumes.
- If the timer is cancelled, you can restore the previous setting by pressing SET button.

HOW TO OPERATE

Timer

1

Select ON or OFF timer.

2

Set the desired time.



3

Confirm the setting.

CANCEL

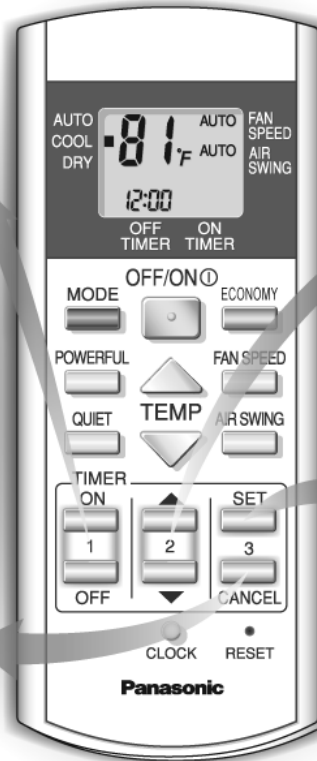
Cancel the selected timer.



- Ensure the clock on the remote control has been set correctly.
- You can set both the ON and OFF timers at the same time.
- To cancel either the ON or OFF timer, press  or , then press .

Hints



- Press CLOCK button for more than 10 seconds to change the time format - from AM/PM format to 24 hour format.
- For your convenience, you can set the air conditioner to operate automatically by using both ON and OFF timer.

Troubleshooting



- TIMER indicator always on. > Timer is activated and the setting will repeat itself daily.
- POWER indicator is blinking 15 minutes before ON timer is activated. > The unit is determining the operation mode by sensing the room temperature. This happens when it has been set to AUTO operation mode.

CARE & CLEANING



Switch off the power supply before cleaning

FRONT PANEL

Raise and pull to remove.
Wash and dry.

AIR FILTER

Vacuum, wash and dry.

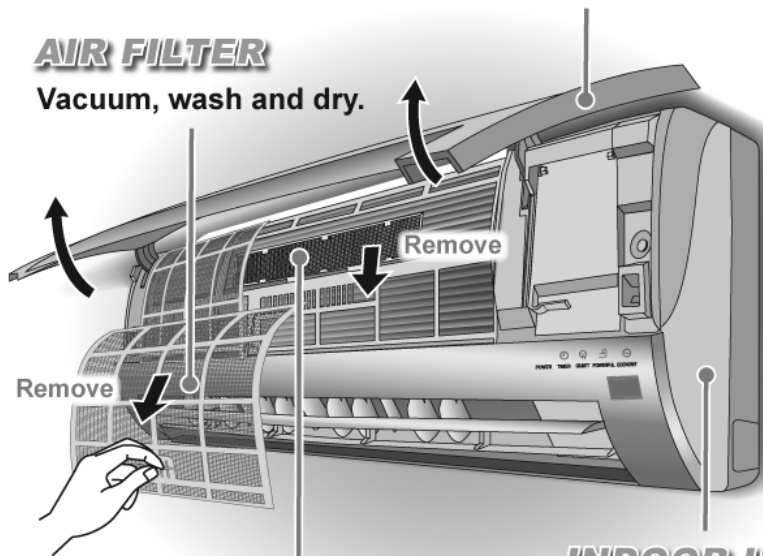

AIR PURIFYING FILTER

INDOOR UNIT

Wipe gently.

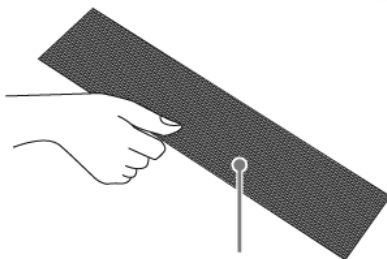

Vacuum the Air Purifying filter.

Washing Instructions

- Do not use benzene, thinner or scouring powder.
- Use soaps or neutral household detergent (≈pH7) only.
- Do not use water warmer than 104°F.

INDOOR UNIT

- Wipe the unit gently with a soft, dry cloth.

AIR FILTER

- It is recommended that you clean the air filter once every 2 weeks.
- Purchase the replacement filter if it is damaged.
Part no.: CWD001144

AIR PURIFYING FILTER

- It is recommended to clean the filter every 6 months.
- Replace the filter every 3 years or purchase the replacement filter if it is damaged.
Part no.: CZ-SA20P

Pre-season Inspection

- This inspection is recommended before operating the air conditioner in every season.
- Check if the remote control batteries need to be replaced.
- Ensure there is no obstruction at all air intake and outlet vents.
- After the unit has been operating for 15 minutes, it is normal if the temperature difference between air intake and outlet vents at indoor unit is:

Operation	Temperature
Cooling	> 14°F

Hints



- Clean the filter regularly as dirty filters will cause unpurified air, low cooling capacity, unpleasant smells and higher energy consumption.
- The unit will become dirty and the performance of the unit will decrease after being used for several seasons. Please consult an authorized dealer to perform seasonal inspections in addition to regular cleaning.
- This air conditioner is equipped with a built-in surge protective device. However, in order to further protect your air conditioner from being damaged by abnormally strong lightning activity, you may switch off the power supply.

10 Installation Instructions

Required tools for Installation Works			
1. Philips screw driver	5. Spanner	9. Gas leak detector	13. Multimeter
2. Level gauge	6. Pipe cutter	10. Measuring tape	14. Torque wrench 13.3 lbf.ft 31.0 lbf.ft 40.6 lbf.ft
3. Electric drill, hole core drill ($\varnothing 2 \frac{3}{4}$ ")	7. Reamer	11. Thermometer	15. Vacuum pump
4. Hexagonal wrench (5/32")	8. Knife	12. Megameter	16. Gauge manifold

10.1. Safety Precautions

- Read the following "SAFETY PRECAUTIONS" carefully before installation.
- Electrical work must be installed by a licensed electrician.
- The caution items stated here must be followed because these important contents are related to safety. The meaning of each indication used is as below. Incorrect installation will cause harm or damage, and the seriousness is classified by the following indications.

 WARNING	This indication shows the possibility of causing death or serious injury.
---	---

 CAUTION	This indication shows the possibility of causing injury or damage to properties only.
---	---

The items to be followed are classified by the symbols:

	Symbol with white background denotes an item that is PROHIBITED.
--	--

- Carry out test running to confirm that no abnormality occurs after the installation. Then, explain to user the operation, care and maintenance as stated in instructions. Please remind the customer to keep the operating instructions for future reference.

 WARNING	
1.	Engage dealer or specialist for installation. If installation done by the user is defective, it will cause water leakage, electrical shock or fire.
2.	Install according to this installation instruction strictly. If installation is defective, it will cause water leakage, electrical shock or fire.
3.	Use the attached accessories parts and specified parts for installation. Otherwise, it will cause the set to fall, water leakage, fire or electrical shock.
4.	Install at a strong and firm location which is able to withstand the set's weight. If the strength is not enough or installation is not properly done, the set will drop and cause injury.
5.	For electrical work, follow the local national wiring standard, regulation and this installation instruction. An independent circuit and single outlet must be used. If electrical circuit capacity is not enough or defect found in electrical work, it will cause electrical shock or fire.
6.	Use the UL listed or CSA approved AWG16 wire (or heavier wire) and connect tightly for indoor/outdoor connection. Connect tightly and clamp the wire so that no external force will be acted on the terminal. If connection or fixing is not perfect, it will cause heat-up or fire at the connection.
7.	Wire routing must be properly arranged so that control board cover is fixed properly. If control board cover is not fixed perfectly, it will cause heat-up at connection point of terminal, fire or electrical shock.
8.	When carrying out piping connection, take care not to let air substances other than the specified refrigerant go into refrigeration cycle. Otherwise, it will cause lower capacity, abnormal high pressure in the refrigeration cycle, explosion and injury.







CAUTION

1. The equipment must be earthed and installed with earth leakage current breaker. It may cause electrical shock if grounding is not perfect.
2. Do not install the unit at place where leakage of flammable gas may occur. In case gas leaks and accumulates at surrounding of the unit, it may cause fire. 
3. Carry out drainage piping as mentioned in installation instructions. If drainage is not perfect, water may enter the room and damage the furniture.

ATTENTION

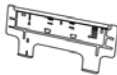
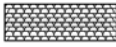
1. Selection of the installation location.
Select an installation location which is rigid and strong enough to support or hold the unit, and select a location for easy maintenance.
2. Power supply connection to the room air conditioner.
Connect the power supply of the room air conditioner to the mains.
Power supply point should be in easily accessible place for the power disconnection in case of emergency.
Power supply connection to a circuit breaker for the permanent connection. Use an approved 15A (CU-C9DK) and 25A (CU-C12DK) fuse or circuit breaker for the permanent connection.
It must be a double pole switch with a minimum 1/8" contact gap.
3. Do not release refrigerant.
Do not release refrigerant during piping work for installation, reinstallation and during repairing a refrigeration parts. Take care of the liquid refrigerant, it may cause frostbite.
4. Installation work.
Two people may be required to carry out installation.
5. Do not install this appliance in a laundry room or other location where water may drip from the ceiling, etc.

10.2. Attached accessories

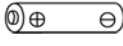
No.	Accessories part	Qty.	No.	Accessories part	Qty.
1	Installation plate 	1	5	Air purifying filter 	1
2	Installation plate fixing screw 	6	6	Remote control holder 	1
3	Remote control 	1	7	Remote control holder fixing screw 	2
4	Battery 	2			

Applicable piping kit
CZ-3F5, 7AEN (C9DK)
CZ-4F5,7, 10AN (C12DK)

10.3. Select the best location

INDOOR UNIT

- There should not be any heat source or steam near the unit.
- There should not be any obstacles blocking the air circulation.
- A place where air circulation in the room is good.
- A place where drainage can be easily done.
- A place where noise prevention is taken into consideration.
- Do not install the unit near the door way.
- Ensure the spaces indicated by arrows from the wall, ceiling, fence or other obstacles.
- Recommended installation height for indoor unit shall be at least 7'6".

OUTDOOR UNIT

- If an awning is built over the unit to prevent direct sunlight or rain, be careful that heat radiation from the condenser is not obstructed.
- There should not be any animal or plant which could be affected by hot air discharged.
- Keep the spaces indicated by arrows from wall, ceiling, fence or other obstacles.
- Do not place any obstacles which may cause a short circuit of the discharged air.
- If piping length is over the rated length, additional refrigerant should be added as shown in the table.

Model	Piping size		Rated Length ft (m)	Max. Elevation ft (m)	Max. Piping Length ft (m)	Additional Refrigerant (g/m)
	Gas	Liquid				
CS-C9DK	3/8"	1/4"	24.6 ft (7.5 m)	16.4 ft (5 m)	32.8 ft (10 m)	0.11 oz/ft (10 g/m)
CS-C12DK	1/2"	1/4"	24.6 ft (7.5 m)	16.4 ft (5 m)	49.2 ft (15 m)	0.11 oz/ft (10 g/m)

10.4. Indoor/Outdoor Unit Installation Diagram

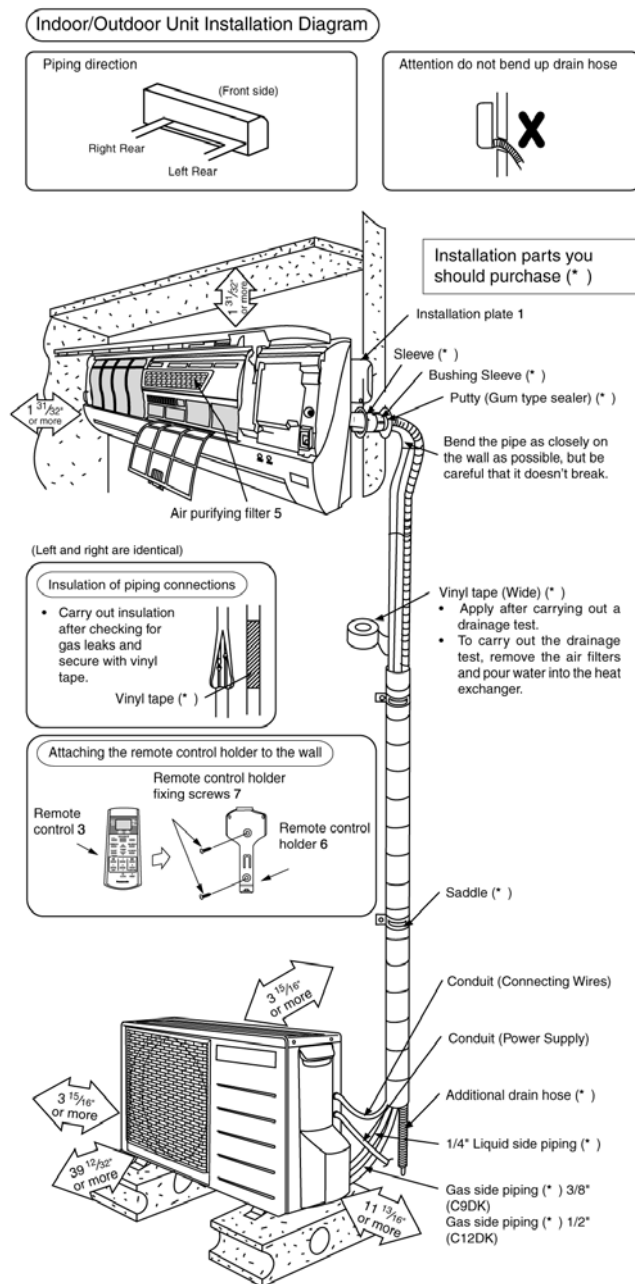

- This illustration is for explanation purposes only. The indoor unit will actually face a different way.

10.5. Indoor unit

10.5.1. SELECT THE BEST LOCATION (Refer to "Select the best location" section)

10.5.2. HOW TO FIX INSTALLATION PLATE

The mounting wall is strong and solid enough to prevent it from the vibration.

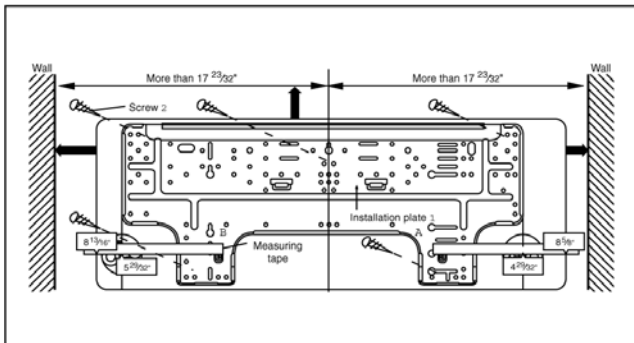

- The wall must be able to withstand the weight of the unit.
- The centre of installation plate should be at more than $1723/32$ " at right and left of the wall.
- From installation plate left edge to unit's left side is $229/32$ ".
- The distance from installation plate edge to ceiling should more than $25/8$ ".
- From installation plate right edge to unit's right is $345/64$ ".

- Ⓑ : For left side piping, piping connection for liquid should be about $19/32$ " from this line.
- : For left side piping, piping connection for gas should be about $1198/256$ " from this line.
- : For left side piping, piping connecting cable should be about $31127/256$ " from this line.

1. Mount the installation plate on the wall with 5 screws or more.
(If mounting the unit on the concrete wall consider using anchor bolts.)
 - Always mount the installation plate horizontally by aligning the marking-off line with the thread and using a level gauge.
2. Drill the piping plate hole with $\varnothing 23/4$ " hole-core drill.
 - Line according to left and right side of the installation plate. The meeting point of the extended line is the centre of the hole. Another method is by putting measuring tape at position as shown in the diagram above. The hole centre is obtained by measuring the distance namely $529/32$ " and $429/32$ " for left and right hole respectively.
 - Drill the piping hole at either the right or the left and the hole should be slightly slanted to the outdoor side.

10.5.3. TO DRILL A HOLE IN THE WALL AND INSTALL A SLEEVE OF PIPING

1. Insert the piping sleeve to the hole.
2. Fix the bushing to the sleeve.
3. Cut the sleeve until it extrudes about $19/32$ " from the wall.

Caution

When the wall is hollow, please be sure to use the sleeve for tube ass'y to prevent dangers caused by mice biting the connecting cable.

4. Finish by sealing the sleeve with putty or caulking compound at the final stage.

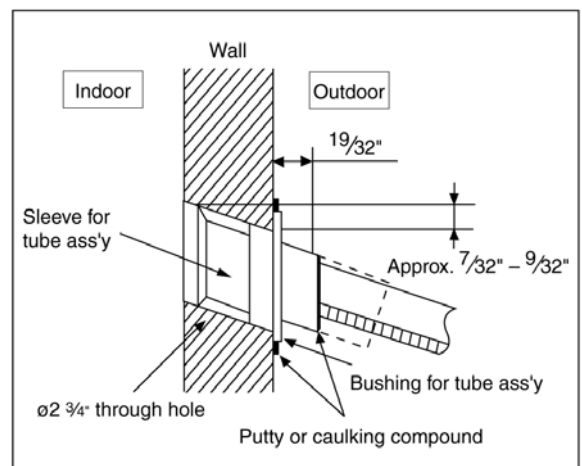

10.5.4. INDOOR UNIT INSTALLATION

1. For the right rear piping

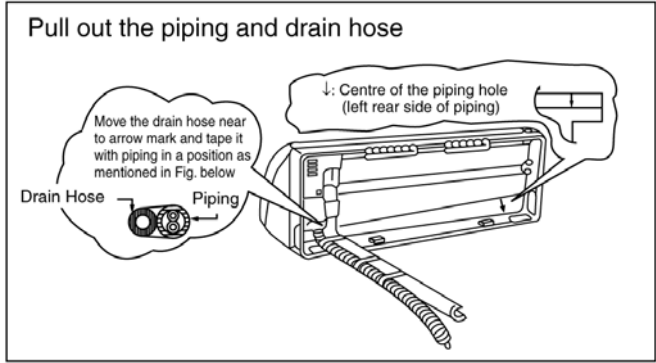
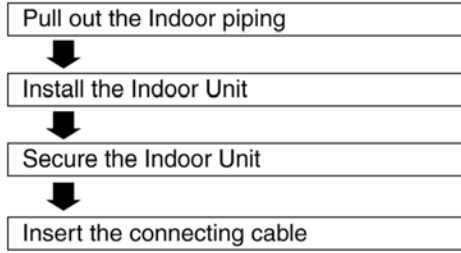

2. For the embedded piping

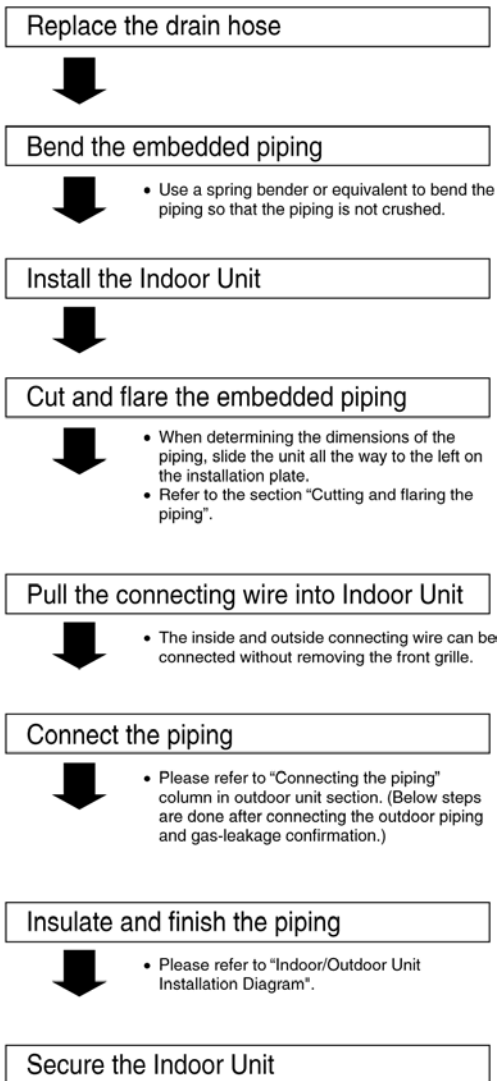

- Use a spring bender or equivalent to bend the piping so that the piping is not crushed.

- When determining the dimensions of the piping, slide the unit all the way to the left on the installation plate.
- Refer to the section "Cutting and flaring the piping".

- The inside and outside connecting wire can be connected without removing the front grille.

- Please refer to "Connecting the piping" column in outdoor unit section. (Below steps are done after connecting the outdoor piping and gas-leakage confirmation.)

- Please refer to "Indoor/Outdoor Unit Installation Diagram".

Insert the connecting cable

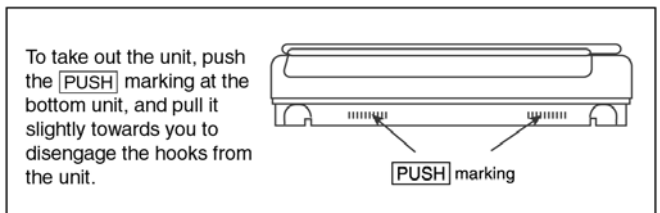
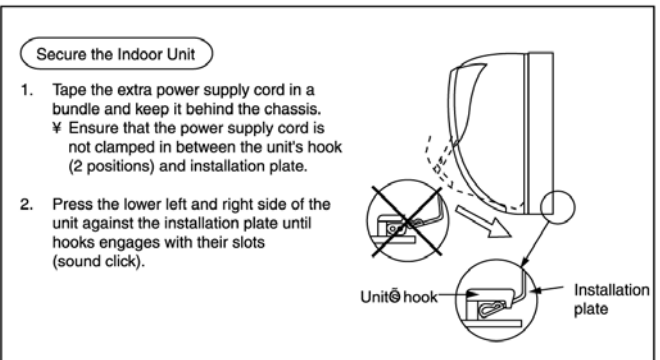
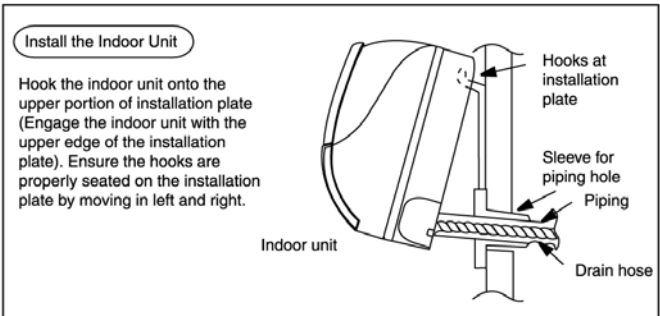
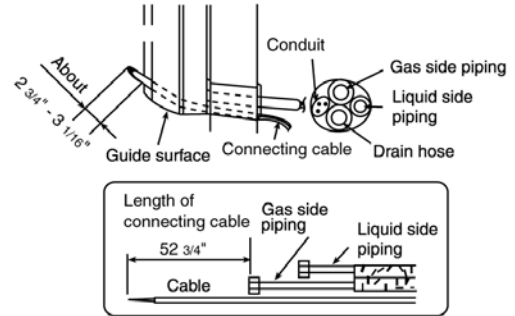

(This can be used for left rear piping & left bottom piping also.)

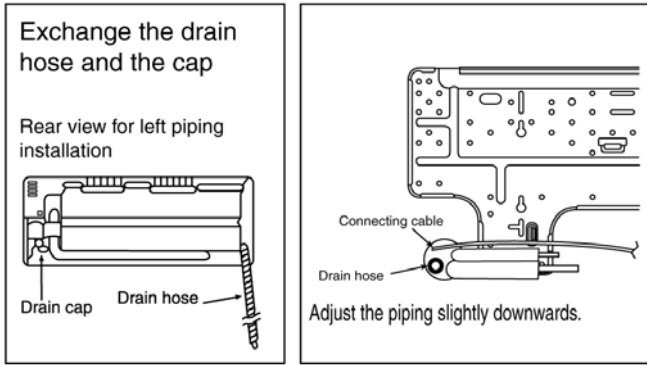

2. Unscrew the conduit cover & fix the conduit connector to conduit cover with lock nut, then secure it against chassis.

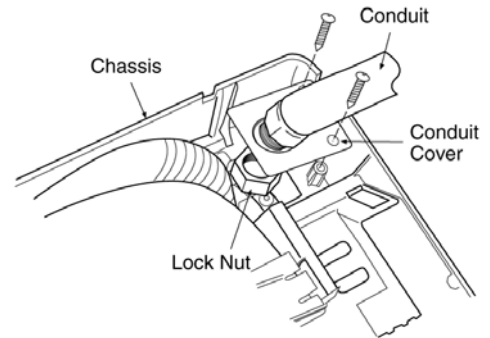

Rear Side of Indoor Unit
View A

3. Connecting wire between indoor unit and outdoor unit should be UL listed or CSA approved 4 x AWG16 wire.

- Ensure the color of wires of outdoor unit and the terminal Nos. are the same to the indoor's respectively.
- Earth lead wire shall be longer than the other lead wires as shown in the figure for the electrical safety in case of the slipping out of the cord from the anchorage.

Terminals on the indoor unit	1	2	3	
Color of wires				
Terminals on the outdoor unit	1	2	3	

- Secure the cable onto the control board with the holder (clammer).

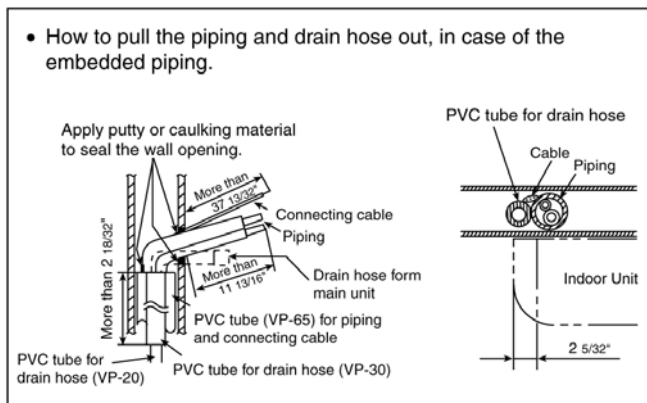
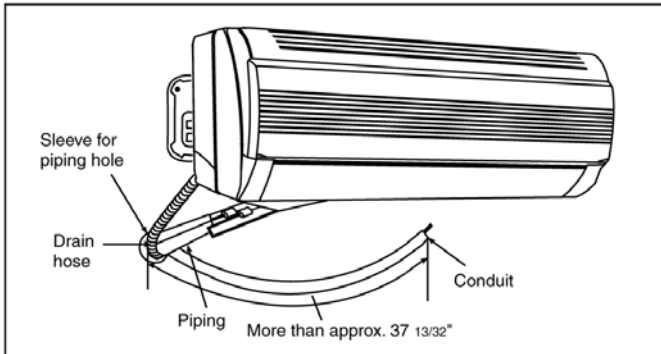
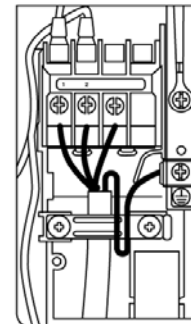

10.5.5. INDOOR UNIT ELECTRICAL WIRING

1. Remove the control board metal cover.

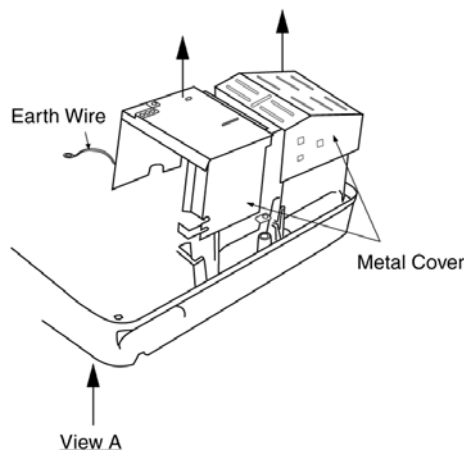

INSTALLATION OF AIR PURIFYING FILTER

1. Open the front panel.
2. Remove the air filters.
3. Put air purifying filter (right) into place as shown in illustration at below.

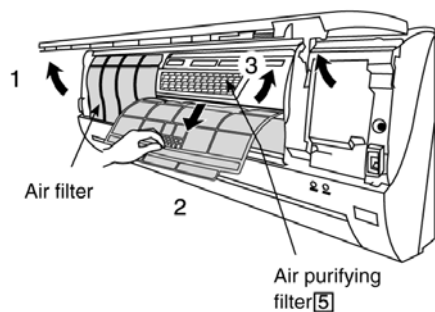

HOW TO TAKE OUT FRONT GRILLE

Please follow the steps below to take out front grille if necessary such as when servicing.

1. Open the intake grille and remove the screw at the front of the front grille.
2. Set the vertical airflow direction louver to the horizontal position.
3. Slide down the 2 caps on the front grille as shown in the illustration at right, and then remove the 2 mounting screws.
4. Pull the lower section of the front grille towards you to remove the front grille.

When reinstalling the front grille, first set the vertical airflow direction louver to the horizontal position and then carry out above steps 2 - 3 in the reverse order.

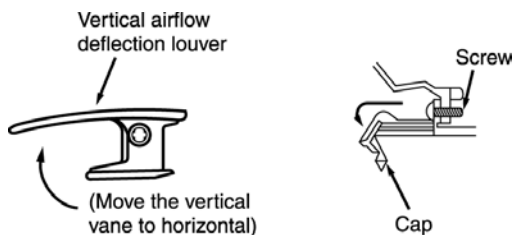

AUTO SWITCH OPERATION

The below operations will be performed by pressing the "AUTO" switch.

1. AUTO OPERATION MODE

The Auto operation will be activated immediately once the Auto Switch is pressed.

2. TEST RUN OPERATION (FOR PUMP DOWN/SERVICING PURPOSE)

The Test Run operation will be activated if the Auto Switch is pressed continuously for more than 5 sec. A "pep" sound will occur at the fifth sec., in order to identify the starting of Test Run operation

3. REMOTE CONTROLLER RECEIVING SOUND ON/OFF

The ON/OFF of Remote Controller receiving sound can be change over by the following steps:

- a) Release the Auto Switch after Test Run operation is activated.
- b) Then, within 20 sec. after (a), press Auto Switch for more than 5 sec..A "beep" "beep" sound will occur at the fifth sec., then release the Auto Switch.
- c) Within 20 sec. after (b), press Auto Switch again.

Everytime Auto Switch is pressed (within 20 sec. interval), remote controller receiving sound status will be reversed between ON and OFF.

Long "beep" sound indicates that remote controller receiving sound is OFF.

Short "beep" sound indicates that remote controller receiving sound is ON.

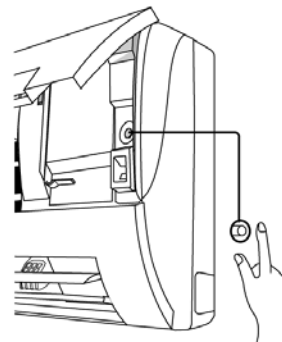

10.6. Outdoor unit

10.6.1. SELECT THE BEST LOCATION (Refer to "Select the best location" section)

10.6.2. INSTALL THE OUTDOOR UNIT

- After selecting the best location, start installation according to Indoor/Outdoor Unit Installation Diagram.

1. Fix the unit on concrete or rigid frame firmly and horizontally by bolt nut. ($\varnothing 13/32$ ").
2. When installing at roof, please take into consideration strong winds and earthquakes. Please fasten the installation stand firmly with bolt or nails.

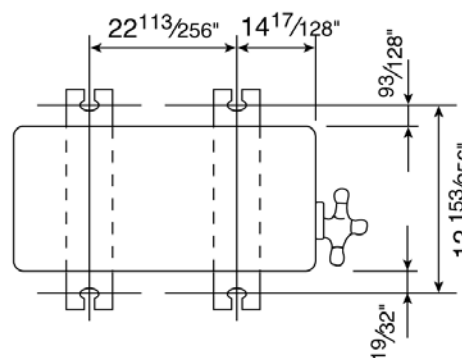

10.6.3. CONNECTING THE PIPING

Connecting The Piping To Indoor Unit

Please make flare after inserting flare nut (locate at joint portion of tube assembly) onto the copper pipe. (In case of using long piping)

Connect the piping

- Align the center of piping and sufficiently tighten the flare nut with fingers.
- Further tighten the flare nut with torque wrench in specified torque as stated in the table.

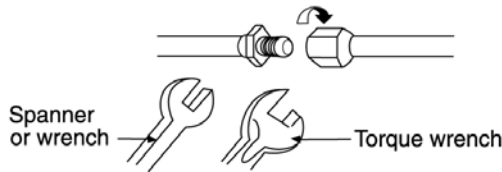

MODEL	Piping size (Torque)	
	Gas	Liquid
CS-C9DK	3/8" (31.0 lbf.ft)	1/4" (13.3 lbf.ft)
CS-C12DK	1/2" (40.6 lbf.ft)	1/4" (13.3 lbf.ft)

Connecting The Piping To Outdoor Unit

Decide piping length and then cut by using pipe cutter. Remove burrs from cut edge. Make flare after inserting the flare nut (located at valve) onto the copper pipe.

Align center of piping to valves and then tighten with torque wrench to the specified torque as stated in the table.

CUTTING AND FLARING THE PIPING

1. Please cut using pipe cutter and then remove the burrs.
2. Remove the burrs by using reamer. If burrs is not removed, gas leakage may be caused.
Turn the piping end down to avoid the metal powder entering the pipe.
3. Please make flare after inserting the flare nut onto the copper pipes.

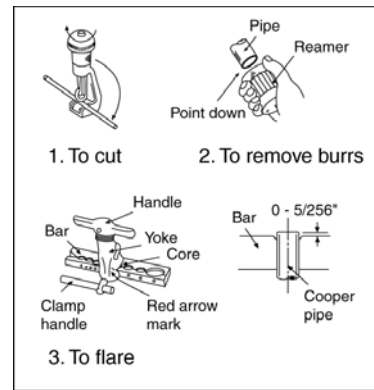

■ Improper flaring ■

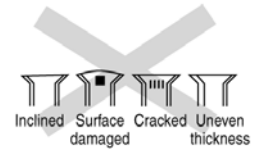

When properly flared, the internal surface of the flare will evenly shine and be of even thickness. Since the flare part comes into contact with the connections, carefully check the flare finish.

10.6.4. EVACUATION OF THE EQUIPMENT

WHEN INSTALLING AN AIR CONDITIONER, BE SURE TO EVACUATE THE AIR INSIDE THE INDOOR UNIT AND PIPES in the following procedure.

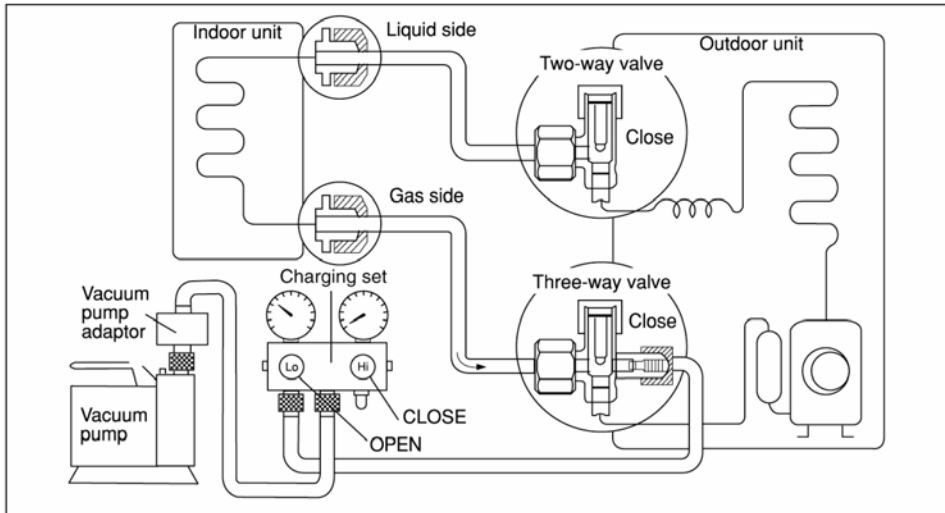

1. Connect a charging hose with a push pin to the Low side of a charging set and the service port of the 3-way valve.
 - Be sure to connect the end of the charging hose with the push pin to the service port.
2. Connect the center hose of the charging set to a vacuum pump with check valve, or vacuum pump and vacuum pump adaptor.
3. Turn on the power switch of the vacuum pump and make sure that the needle in the gauge moves from 0 PSI to -14.5 PSI. Then evacuate the air approximately ten minutes.
4. Close the Low side valve of the charging set and then turn off the vacuum pump. Make sure that the needle in the gauge does not move after approximately five minutes.

Note: BE SURE TO FOLLOW THIS PROCEDURE IN ORDER TO AVOID REFRIGERANT GAS LEAKAGE.
5. Disconnect the charging hose from vacuum pump and from the service port of the 3-way valve.
6. Tighten the service port caps of the 3-way valve at a torque of 4.05 Pf with a torque wrench.
7. Remove the valve caps of both of the 2-way valve and 3-way valve. Position both of the valves to "OPEN" using a hexagonal wrench (5/32").
8. Mount valve caps onto the 2-way valve and the 3-way valve.
 - Be sure to check for gas leakage.

Caution

- If gauge needle does not move from 0 PSI to -14.5 PSI, in step 3 above take the following measure:
- If the leak stops when the piping connections are tightened further, continue working from step 3.
- If the leak does not stop when the connections are retightened, repair the location of leak.
- Do not release refrigerant during piping work for installation and reinstallation. Take care of the liquid refrigerant, it may cause frostbite.

10.6.5. OUTDOOR UNIT ELECTRICAL WIRING

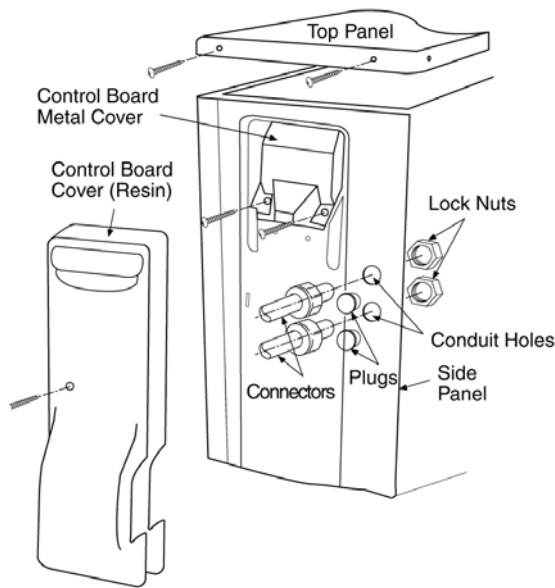

1. Remove Top Panel.
2. Remove Control Board Cover (Metal & Resin).
3. Remove Plugs.

10.6.6. PIPE INSULATION

1. Please carry out insulation at pipe connection portion as mentioned in Indoor/Outdoor Unit Installation Diagram. Please wrap the insulated piping end to prevent water from going inside the piping.
2. If drain hose or connecting piping is in the room (where dew may form), please increase the insulation by using POLY-E FOAM with thickness 1/4" or above.

CHECK THE DRAINAGE

- Open front panel and remove air filters. (Drainage checking can be carried out without removing the front grille.)
- Pour a glass of water into the drain tray-styrofoam.
- Ensure that water flows out from drain hose of the indoor unit.

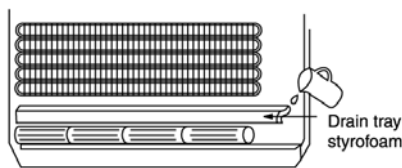

EVALUATION OF THE PERFORMANCE

- Operate the unit at cooling operation mode for fifteen minutes or more.
- Measure the temperature of the intake and discharge air.
- Ensure the difference between the intake temperature and the discharge is more than 14.4°F.

4. Fix the conduit connectors to the conduit holes with lock-nuts, then secure them against the side panel.
5. Connecting wire between indoor unit and outdoor unit should be UL listed or CSA approved 4 × AWG16 wire.

Terminals on the indoor unit	1	2	3	⊕
Color of wires	White	Black	Red	Green
Terminals on the outdoor unit	1	2	3	⊕

6. Secure the wire onto the control board with the holder (clammer).
7. Wire connection to the power supply (115V 60 Hz) through circuit breaker.

- Connect the UL listed or CSA approved wires (AWG14) to the terminal board, and connect the other end of the wires to circuit breaker.

Terminals on the outdoor unit	L1	L2	⊕
Color of wires	White	Black	Green
Terminals on the circuit breaker	(L1)	(L2)	⊕

Note: Secure the wires onto the control board with the holder (clammer).

8. After completing wiring connection, reattach the control board cover and the top panel to the original position with the screws.

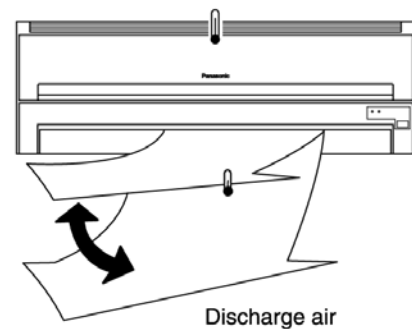

CHECK ITEMS

- Is there any gas leakage at flare nut connections?
- Has the heat insulation been carried out at flare nut connection?
- Is the connecting wiring being fixed to terminal board firmly?
- Is the connecting wiring being clamped firmly?
- Is the drainage OK?
(Refer to "Check the drainage" section)
- Is the earth wire connection properly done?
- Is the indoor unit properly hooked to the installation plate?
- Is the power supply voltage compliant with rated value?
- Is there any abnormal sound?
- Is the cooling operation normal?
- Is the thermostat operation normal?
- Is the remote control's LCD operation normal?
- Is the air purifying filter installed?

11 2-way, 3-way Valve

	2-way Valve (Liquid Side)	3-way Valve (Gas Side)	
Works	Shaft Position	Shaft Position	Service Port
Shipping	Close (With valve cap)	Close (With valve cap)	Close (With cap)
Evacuation (Installation and Re-installation)	Close (Counter-Clockwise)	Close (Clockwise)	Open (Push-pin)
Operation	Open (With valve cap)	Open (With valve cap)	Close (With cap)
Pumping down (Transferring)	Close (Clockwise)	Open (Counter-Clockwise)	Open (Connected manifold gauge)
Evacuation (Servicing)	Open	Open	Open With vacuum pump
Gas charging (Servicing)	Open	Open	Open (With charging cylinder)
Pressure check (Servicing)	Open	Open	Open (Connected manifold gauge)
Gas releasing (Servicing)	Open	Open	Open (Connected manifold gauge)

11.1. Evacuation of Installation

WHEN INSTALLING AN AIR CONDITIONER, BE SURE TO EVACUATE THE AIR INSIDE THE INDOOR UNIT AND PIPES in the following procedure.

If air remain in the indoor unit and refrigeration pipes, it will affect the compressor, reduce to cooling capacity, and could lead to a malfunction.

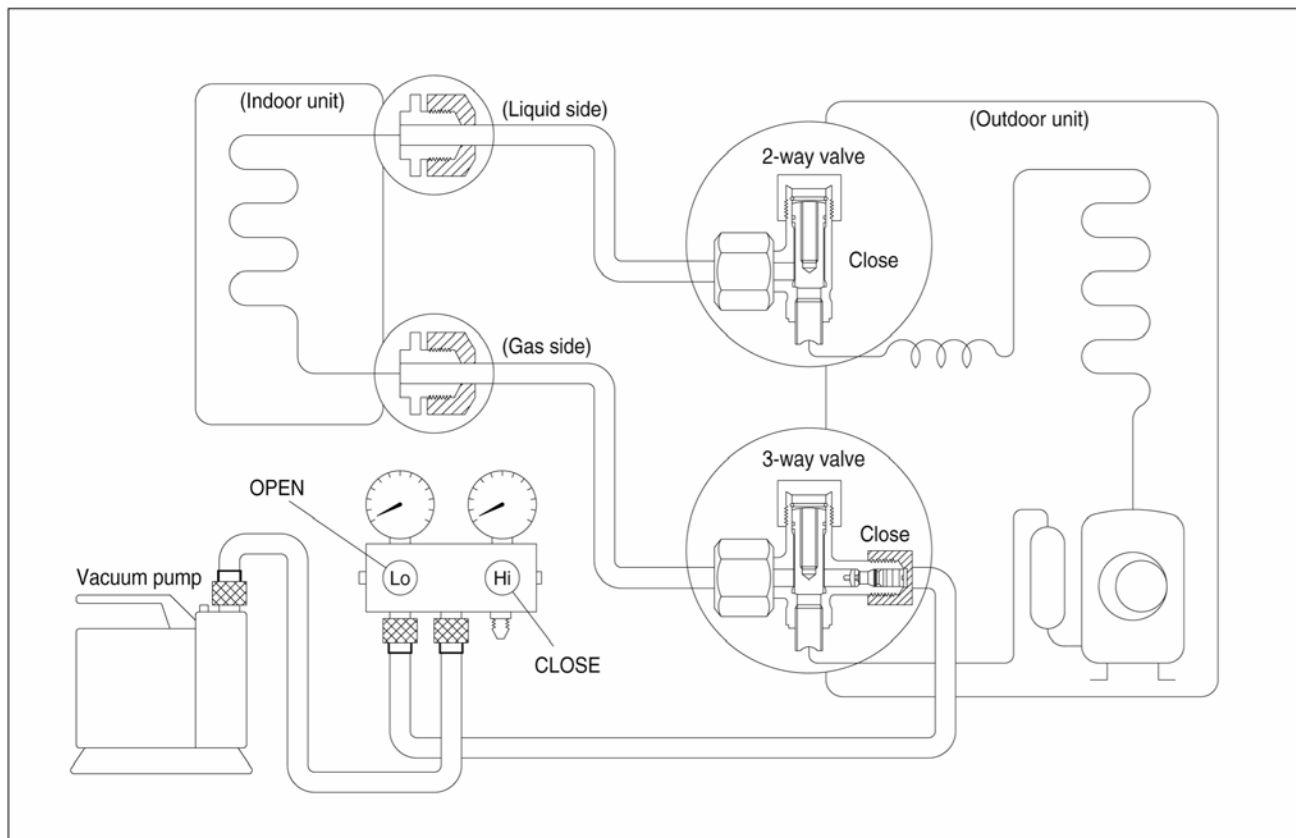

Procedure:

1. Connect a charging hose with a push pin to the Low side of a charging set and the service port of a 3-way valve.
 - Be sure to connect the end of the charging hose with the push pin to the service port.
2. Connect the centre hose of the charging set to a vacuum pump.
3. Turn on the power switch of the vacuum pump and make sure that the needle in the gauge moves from 0 PSI (0 cmHg) to -14.5 PSI (-76 cmHg). Then evacuate the air for approximately ten minutes.
4. Close the Low side valve of the charging set and turn off the vacuum pump. Make sure that the needle in the gauge does not move after approximately five minutes. **BE SURE TO TAKE THIS PROCEDURE IN ORDER TO AVOID GAS LEAKAGE.**
5. Disconnect the charging hose from the vacuum pump and from the service port of the 3-way valve.
6. Tighten the service port cap at a torque of 4.05 lbf with a torque wrench.
7. Remove the valve caps of the 2-way valve and the 3-way valve. Position both of the valves to "open" using a hexagonal wrench (6/32 inch).
8. Mount the valve caps onto the 2-way and 3-way valves.
 - Be sure to check for gas leakage.

Caution

If gauge needle does not move from 0 cmHg to -76 cmHg in step (3) above, take the following measures:

If the leaks stop when the piping connections are tightened further, continue working from step (3).

If the leaks do not stop when the connections are retightened, repair the location of the leak.

11.2. Pumping down

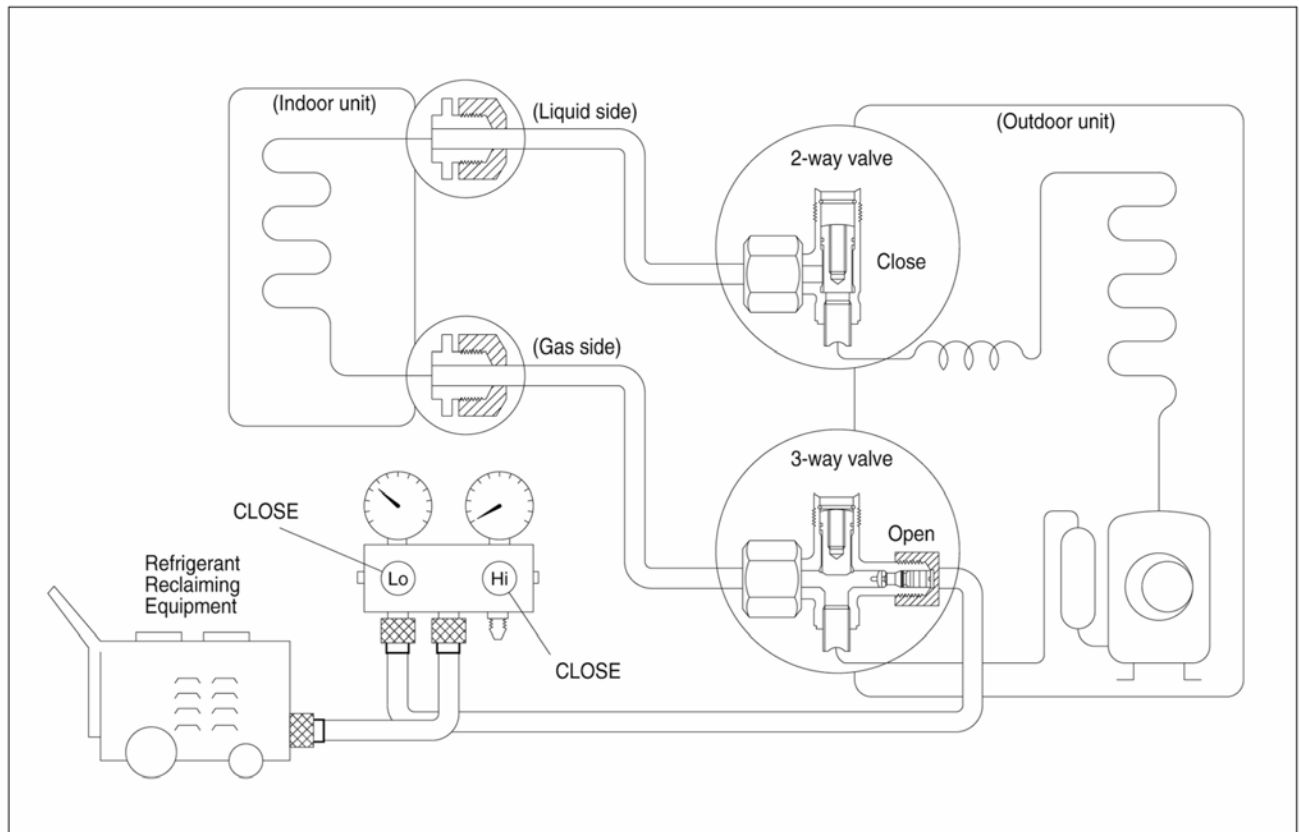

Procedure:

1. **Confirm that both the 2-way and 3-way valves are set to the opened position.**
 - Remove the valve stem caps and confirm that the valve stems are in the opened position.
 - Be sure to use a hexagonal wrench to operate the valve stems.
2. **Operate the unit for 10 to 15 minutes.**
3. **Stop operation and wait for 3 minutes, then connect the charge set to the service port of the 3-way valve.**
 - Connect the charge hose with the push pin to the Gas service port.
4. **Air purging of the charge hose.**
 - Open the low-pressure valve on the charge set slightly to purge air from the charge hose.
5. **Set the 2-way valve to the closed position.**
6. **Operate the air conditioner at the cooling cycle and stop it when the gauge indicates 0 PSI (0 kg/cm²G).**
If the unit cannot be operated at the cooling condition (weather is rather cool), short the Pumping Down pins on the Main Control P.C.B.
(Simply press the pumping down button if it is equipped.)
So that the unit can be operated.
7. **Immediately set the 3-way valve to the closed position.**
 - Do this quickly so that the gauge ends up indicating 14.5 PSI (1 kg/cm²G) to 43.5 PSI (3 kg/cm²G).
8. **Use refrigerant reclaiming equipment to collect refrigerant from indoor unit and pipes.**
9. **Disconnect the charge set, and mount the 2-way and 3-way valve's stem caps and the service port caps.**
 - Use a torque wrench to tighten the service port cap to a torque of 4.05 lbf.
 - Be sure to check for gas leakage.
10. **Disconnect pipes from indoor unit and outdoor unit.**

11.3. Evacuation of Re-installation

WHEN REINSTALLING AN AIR CONDITIONER, BE SURE TO EVACUATE THE AIR INSIDE THE INDOOR UNIT AND PIPES in the following procedure.

If air remain in the indoor unit and refrigeration pipes, it will affect the compressor, reduce to cooling capacity, and could lead to a malfunction.

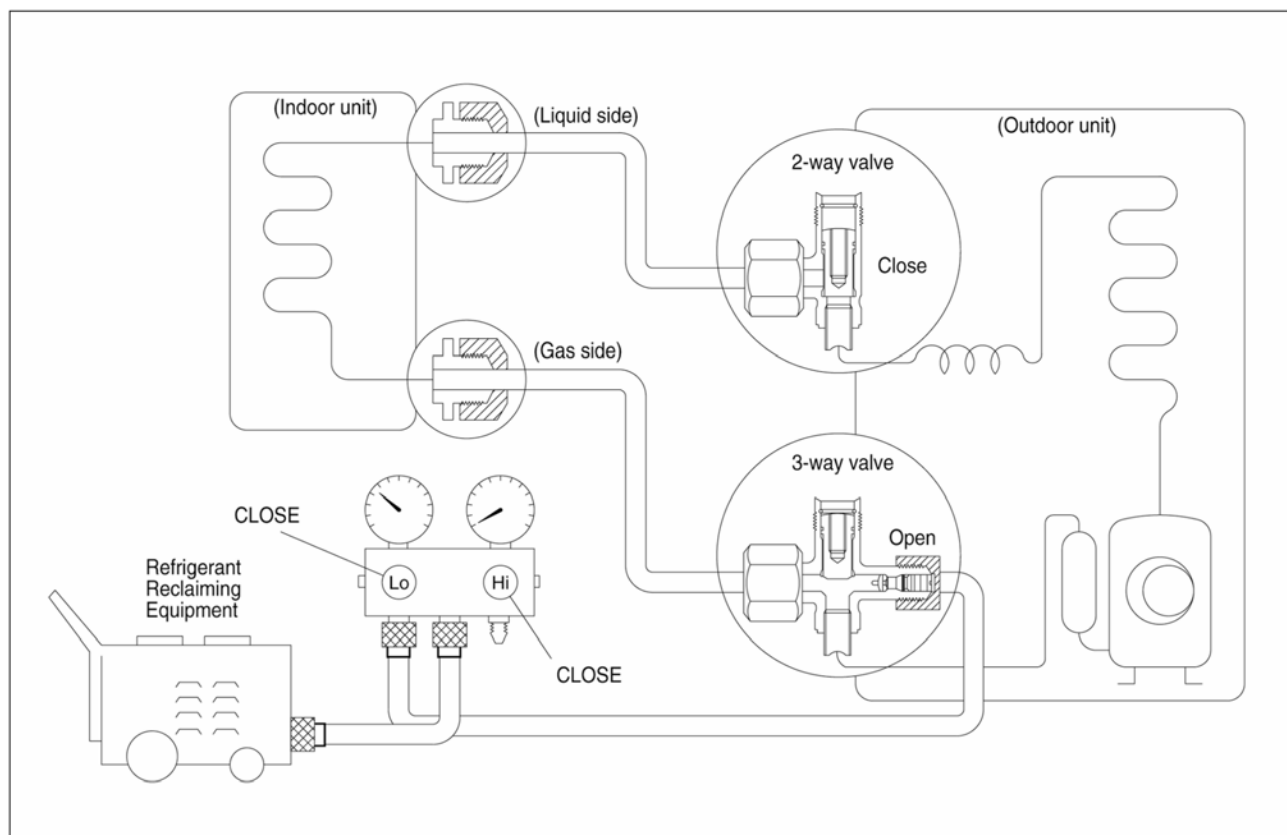

Procedure:

1. Connect a charging hose with a push pin to the Low side of a charging set and the service port of the 3-way valve.
 - Be sure to connect the end of the charging hose with the push pin to the service port.
2. Connect the centre hose of the charging set to a vacuum pump.
3. Turn on the power switch of the vacuum pump and make sure that the needle in the gauge moves from 0 PSI (0 cmHg) to -14.5 PSI (-76 cmHg). Then evacuate the air for approximately ten minutes.
4. Close the Low side valve of the charging set and turn off the vacuum pump. Make sure that the needle in the gauge does not move after approximately five minutes. **BE SURE TO TAKE THIS PROCEDURE IN ORDER TO AVOID GAS LEAKAGE.**
5. Disconnect the charging hose from the vacuum pump.
6. Charge the pipes and indoor unit with gas refrigerant from 3-way valve service port, and then discharge the refrigerant until low side (gas side) gauge needle indicates 43.5 PSI (3 kg/cm²).
7. Tighten the service port cap at a torque of 18 N.m with a torque wrench.
8. Remove the valve caps of the 2-way valve and the 3-way valve. Position both of the valves to "open" using a hexagonal wrench (6/32 inch).
9. Mount the valve caps onto the 2-way and 3-way valves.
 - **BE SURE TO USE REFRIGERANT RECLAIMING EQUIPMENT WHILE DISCHARGING THE REFRIGERANT.**
 - Purge the air from charge set's centre hose.
 - Be sure to check for gas leakage.

Caution

If gauge needle does not move from 0 PSI (0 cmHg) to -14.5 PSI (-76 cmHg) in step (3) above, take the following measures:

If the leaks stop when the piping connections are tightened further, continue working from step 3.

If the leaks do not stop when the connections are retightened, repair the location of the leak.

11.4. Balance refrigerant of the 2-way, 3-way valves

(Lack of refrigerant in the refrigeration cycle)

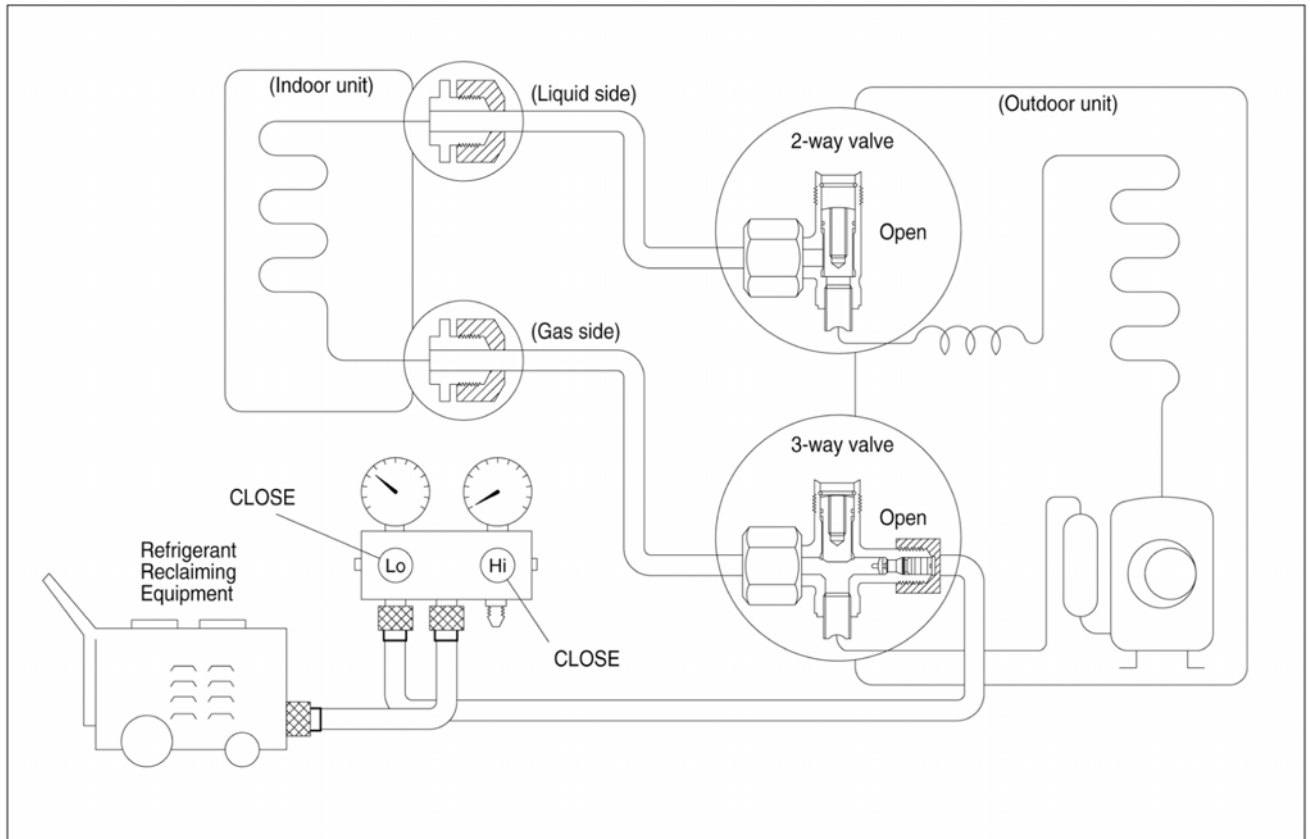

Procedure:

1. Confirm that both the 2-way and 3-way valves are set to the open position.
2. Connect the charge set to the 3-way valve's service port.
 - Leave the valve on the charge set closed.
 - Connect the charge hose with the push-pin to the service port.
3. Connect the charge set's centre hose to refrigerant reclaiming equipment.
 - Purge the air from charge hose.
4. Open the valve (Low side) on the charge set and discharge the refrigerant until the gauge indicates 7.25 PSI (0.5 kg/cm²G) to 14.5 PSI (1 kg/cm²G).
 - If there is no air in the refrigeration cycle (the pressure when the air conditioner is not running is higher than 0.1 PSI (1 kg/cm²G), discharge the refrigerant until the gauge indicates 7.25 PSI (0.5 km/cm²G) to 14.5 PSI (1 kg/cm²G). If this is the case, it will not be necessary to apply an evacuation.
 - Discharge the refrigerant gradually; if it is discharged too suddenly, the refrigeration oil will also be discharged.
5. Turn on refrigerant reclaiming equipment.

11.5. Evacuation

(No refrigerant in the refrigeration cycle)

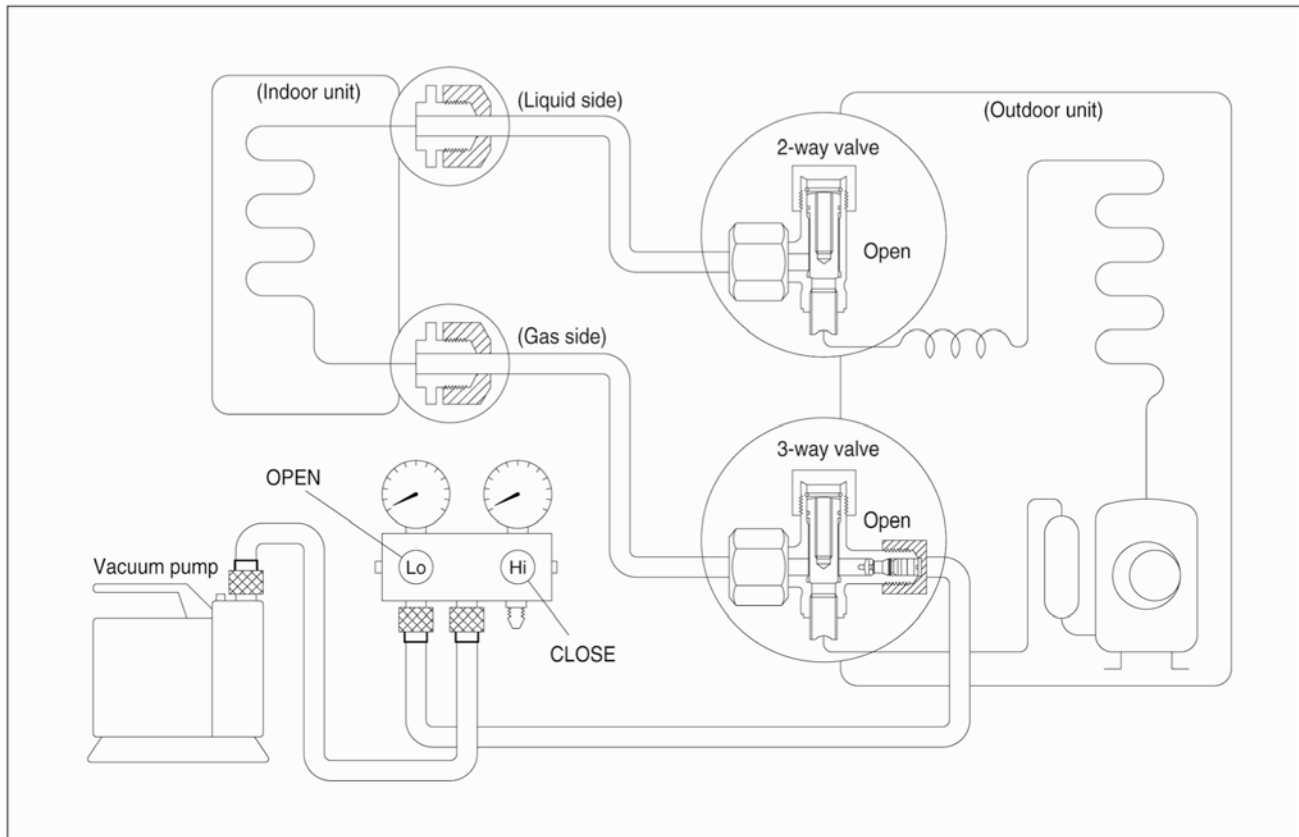

Procedure:

1. Connect the vacuum pump to the charge set's centre hose.
2. Evacuation for approximately one hour.
 - Confirm that the gauge needle has moved toward -14.5 PSI (-76 cmHg) [vacuum of 4 mmHg or less.]
3. Close the valve (Low side) on the charge set, turn off the vacuum pump, and confirm that the gauge needle does not move (approximately 5 minutes after turning off the vacuum pump).
4. Disconnect the charge hose from the vacuum pump.
 - Vacuum pump oil
 - If the vacuum pump oil becomes dirty or depleted, replenish as needed.

11.6. Gas charging

(After Evacuation)

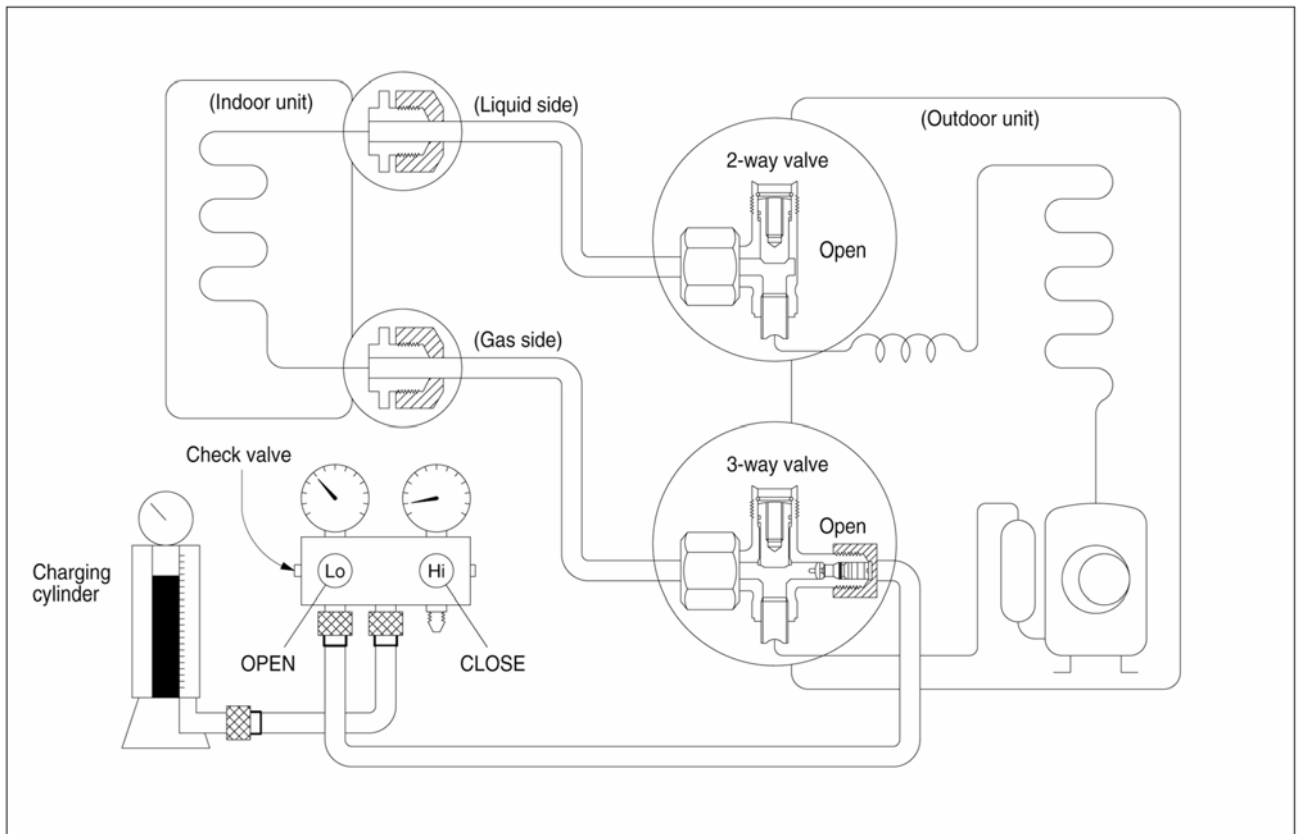

Procedure:

1. Connect the charge hose to the charging cylinder.

- Connect the charge hose which you disconnected from the vacuum pump to the valve at the bottom of the cylinder.

2. Purge the air from the charge hose.

- Open the valve at the bottom of the cylinder and press the check valve on the charge set to purge the air (be careful of the liquid refrigerant).

3. Open the valve (Low side) on the charge set and charge the system with liquid refrigerant.

- If the system cannot be charged with the specified amount of refrigerant, it can be charged with a little at a time (approximately 0.33 lb each time) while operating the air conditioner in the cooling cycle; however, one time is not sufficient, wait approximately 1 minute and then repeat the procedure. (pumping down-pin)

This is different from previous procedures. Because you are charging with liquid refrigerant from the gas side, absolutely do no attempt to charge with large amount of liquid refrigerant while operating the air conditioner.

4. Immediately disconnect the charge hose from the 3-way valve's service port.

- Stopping partway will allow the refrigerant to be discharged.
- If the system has been charged with liquid refrigerant while operating the air conditioner, turn off the air conditioner before disconnecting the hose.

5. Mount the valve stem caps and the service port cap.

- Use torque wrench to tighten the service port cap to a torque of 4.05 lbf.
- Be sure to check for gas leakage.

12 Servicing Information

12.1. Distinction of Lead Free (PbF) Printed Circuit Board

- Printed circuit boards (manufactured) using lead free solder will have a PbF stamp on the Printed Circuit board.

CAUTION

- Pb free solder has a higher melting point than standard solder; typically the melting point is 50 - 70°F (30 - 40°C) higher. Please use a high temperature solder iron and set it to 700 ± 20°F (370 ± 10°C).
- Pb free solder will tend to splash when heated too high (about 1100°F/600°C).
- If you must use Pb solder, please completely remove all of the Pb free solder on the pin or solder area before applying Pb solder. If this is not practical, be sure to heat the Pb free solder until it melts, before applying Pb solder.

12.2. Indoor Electronic Controller Removal Procedures

- Electronic controller and Display Complete unit can be seen by following the below removal procedures.



Remove 2 caps and screws

Fig. 1

- Remove the 2 caps and 2 screws at the bottom of the Front Grille.(Fig.1)



Front Grille Complete

Fig. 2

- Remove the Front Grille Complete. (Fig.2)

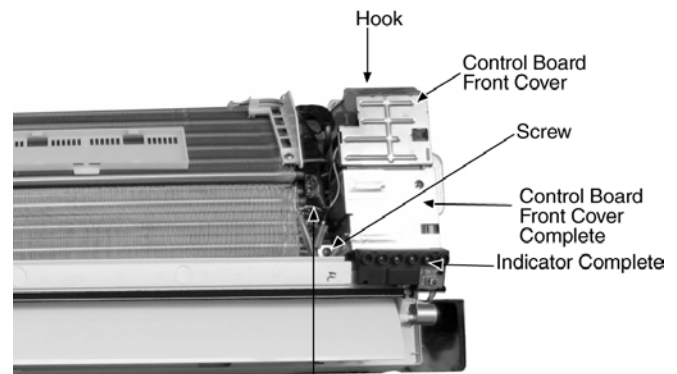

Earth Wire

Fig. 3

- Release the hooks on top and on the left side of Control Board Front Cover.(Fig.3)
- Then remove the Control Board Front Cover.(Fig.3)
- Remove the earth wire.(Fig.3)
- Release the screw on the left side of the Control Board Front Cover Complete.(Fig.3)
- Then remove the Control Board Front Cover Complete.(Fig.3)

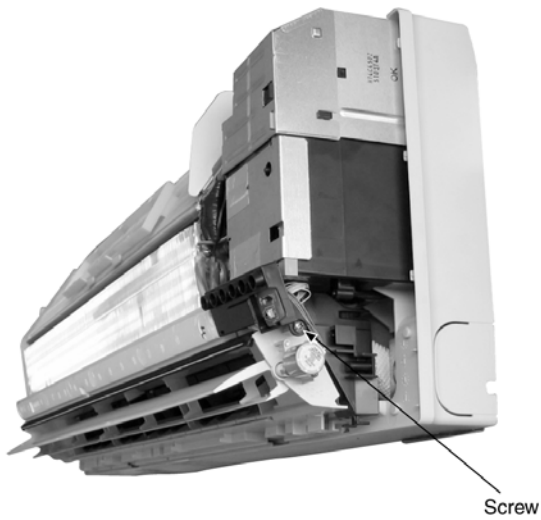

Fig. 4

- Remove the indicator complete screw, and then remove the Indicator Complete.(Fig.4)

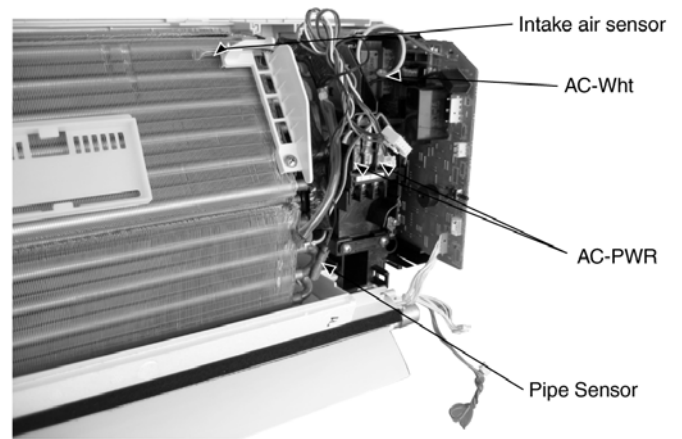

Fig. 6

- Press the hook to the right then take out the PCB (Fig.6)
- Remove Ry-Pwr connector (black and brown) from the terminal board. (Fig.6)
- Remove AC-Wht connector from the PCB. (Fig.6)

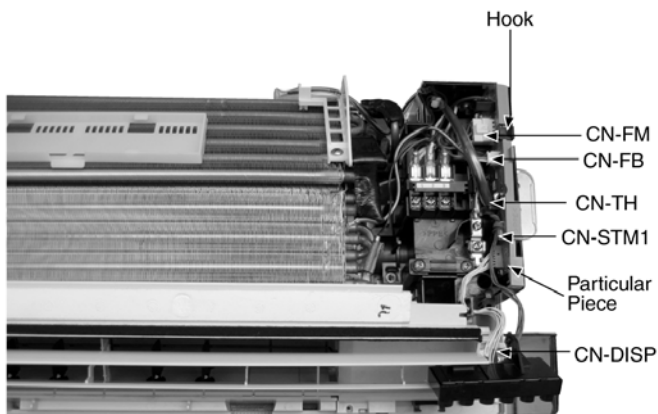

Fig. 5

- To remove the electronic controller.
- Remove the particular piece (Fig.5).
- Release CN-FM connector (Fig.)
- Release CN-FB connector (Fig.5)
- Release CN-TH connector (Fig.5)
- Release CN-STM1 connector (Fig.5)
- Release CN-DISP connector (Fig.5)

12.3. Indoor Fan Motor and Cross Flow Fan Removal Procedures

- Remove Control Board cover

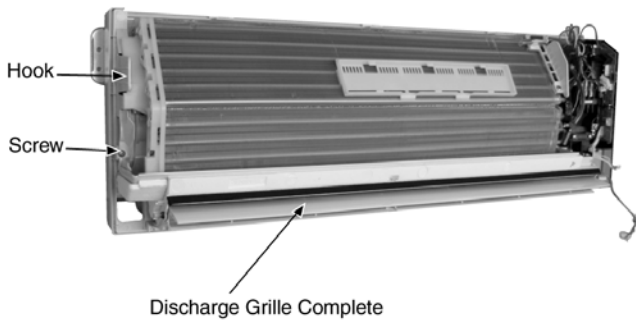

Fig. 7

- Remove the screw on the left side of the unit. (Fig.7)
- Pull the hook to the left and lift up the evaporator. (Fig. 7)
- Pull down the Discharge Grille Complete. (Fig.7)



Fig. 9

- Remove the cross flow fan bushing from the chassis. (Fig.9)
- Loosen the fan boss screw at the cross flow fan. (Fig.9)

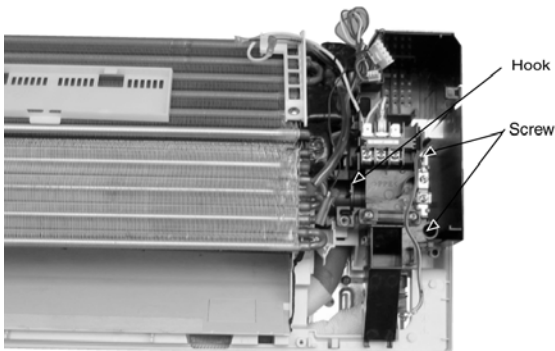

Fig. 8

- Remove indoor pipe sensor and air intake sensor from the evaporator. (Fig.8)
- Remove 2 screws on the right side of the control board. (Fig.8)
- Press down the hook on the left side of control board. (Fig.8)
- Then pull out the Control Board Complete from the unit. (Fig.8)

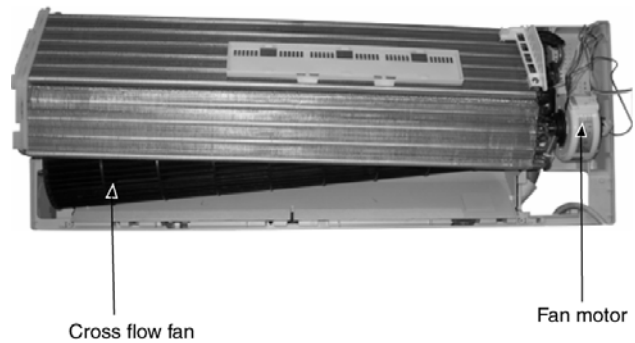
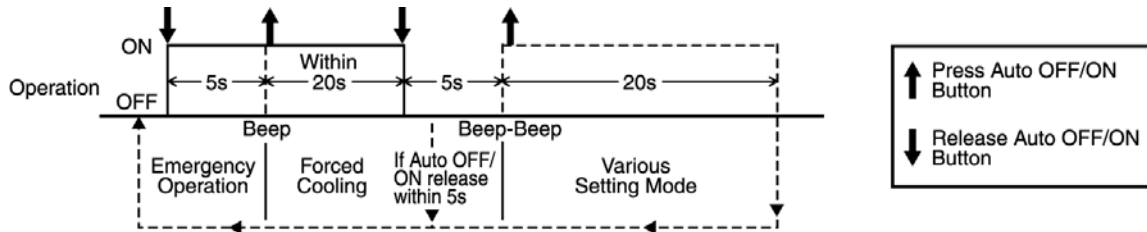

Fig. 10

- Push up the evaporator and remove cross flow fan by pulling both cross flow fan and fan motor. (Fig.10)

12.4. Auto OFF/ON Button

- The “Auto OFF/ON Button” (behind the front grille) is used to operate the air conditioner if remote control is misplaced or malfunctioning.
- Forced cooling operation is possible by pressing the “Auto OFF/ON Button” for more than 5s where “beep” sound is heard then release the button.
- User able to select remote control transmission code and toggle remote control signal receiving sound under various setting mode.
- To enter various setting mode:
 - Press the “Auto OFF/ON Button” continuously for 5s (“beep” sound is heard) and release.
 - Within 20s, press the “Auto OFF/ON Button” continuously for 5s again (2 “beep” sound is heard) and release.
 - Various setting mode has limit up to 20s. Then return to normal operation.



12.4.1. Toggle Remote Control Signal Receiving Sound

- Under various setting mode, press the “Auto OFF/ON Button” to toggle the remote control sound.
 - Short “beep”: Turn ON remote control signal receiving sound.
 - Long “beep”: Turn OFF remote control signal receiving sound.
- After “Auto OFF/ON Button” is pressed, the 20s counter for various setting mode is restarted.

12.4.2. Remote Control Transmission Code

- There are 4 types of remote control transmission code could be selected and stored in EEPROM of indoor unit. The indoor unit will only operate when received signal with same transmission code from remote control. This could prevent signal interference when there are 2 or more indoor unit installed nearby together.
- To change remote control transmission code, short or open jumpers at the remote control printed circuit board.

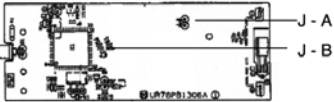
Remote Control Printed Circuit Board	Transmission Code Combination		
	J - A	J - B	Remote Control No.
	Short	Open	A (Default)
	Open	Open	B
	Short	Short	C
	Open	Short	D

- Under various setting mode, after select the transmission code combination of remote control, press any button of remote control to transmit a signal to indoor unit. The transmission code will be stored in EEPROM.
- After signal is received, the various setting mode is cancelled and return to normal operation.

12.5. Remote Control Reset

- When the batteries are inserted for the first time or the batteries are replaced, you may notice the indications at remote control's display screen blink continuously and not functionable. If this condition happens, try to reset the remote control by pushing the reset terminal with a pointing device.
- You may also do the reset to erase the setting at remote control and restore back the default setting.

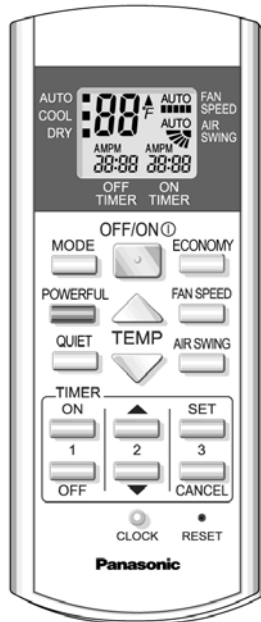

13 Troubleshooting Guide

13.1. Refrigeration cycle system

In order to diagnose malfunctions, make sure that there is no electrical problem before inspecting the refrigeration cycle. Such problems include insufficient insulation, problem with the power source, malfunction of compressor or fan motor.

The normal outlet air temperature and pressure of the refrigeration cycle depend on various conditions, the standard values for them are shown in the table to the right.

Normal Pressure and Outlet Air Temperature (Standard)

	Gas pressure psi (kg/cm ² G)	Outlet air temperature (°F)
Cooling Mode	58.02 ~ 87.02 (4 ~ 6)	53.4 ~ 60.8

* Condition: Indoor fan speed: High
Outdoor temperature: 95°F

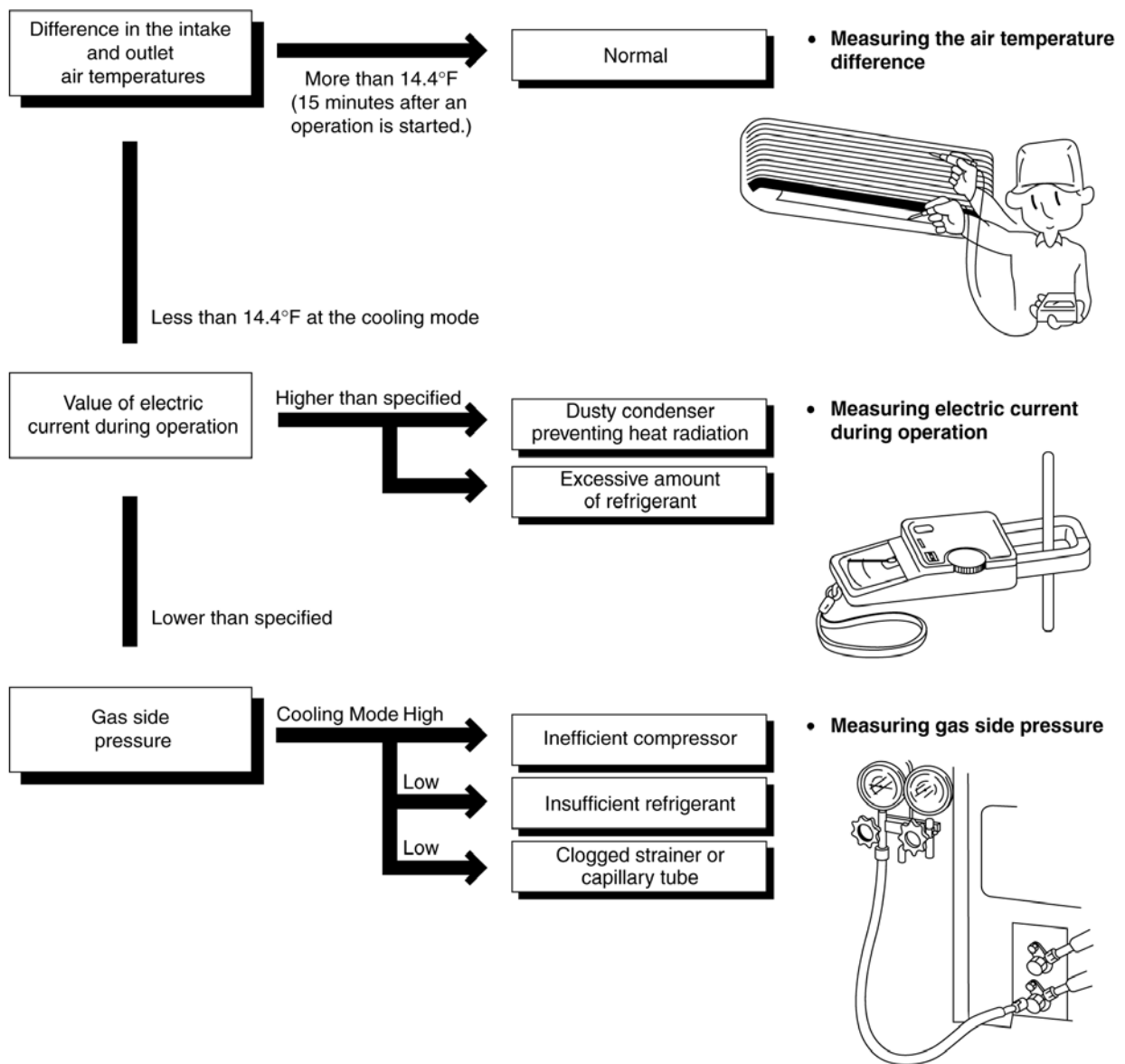

13.2. Relationship between the condition of the air conditioner and pressure and electric current

Condition of the air conditioner	Cooling Mode		
	Low Pressure	High Pressure	Electric current during operation
Insufficient refrigerant (gas leakage)	➔	➔	➔
Clogged capillary tube or Strainer	➔	➔	➔
Short circuit in the indoor unit	➔	➔	➔
Heat radiation deficiency of the outdoor unit	➔	➔	➔
Inefficient compression	➔	➔	➔

- Carry out the measurements of pressure, electric current, and temperature fifteen minutes after an operation is started.

13.3. Diagnosis methods of a malfunction of a compressor

Nature of fault	Symptom
Insufficient compressing of a compressor	<ul style="list-style-type: none"> • Electric current during operation becomes approximately 20% lower than the normal value. • The discharge tube of the compressor becomes abnormally hot (normally 154 to 194°F). • The difference between high pressure and low pressure becomes almost zero.
Locked compressor	<ul style="list-style-type: none"> • Electric current reaches a high level abnormally, and the value exceeds the limit of an ammeter. In some cases, a breaker turns off. • The compressor has a humming sound.

14 Technical Data

14.1. Thermostat characteristics

CS-C9DK / CS-C12DK

• Cooling

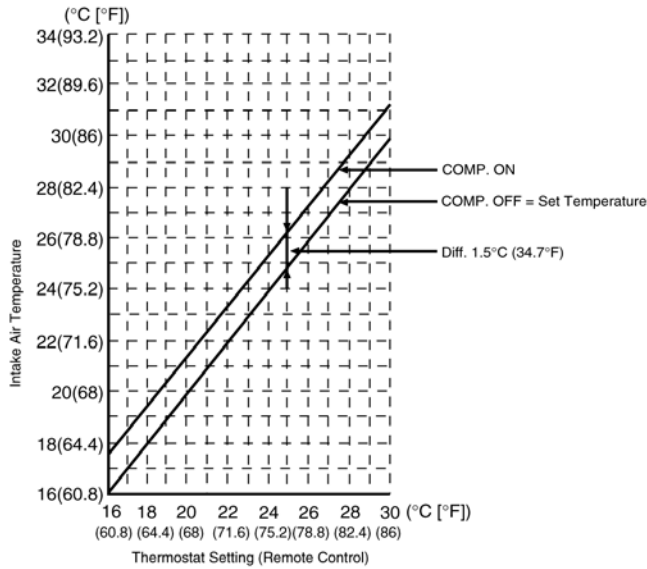

• Soft Dry

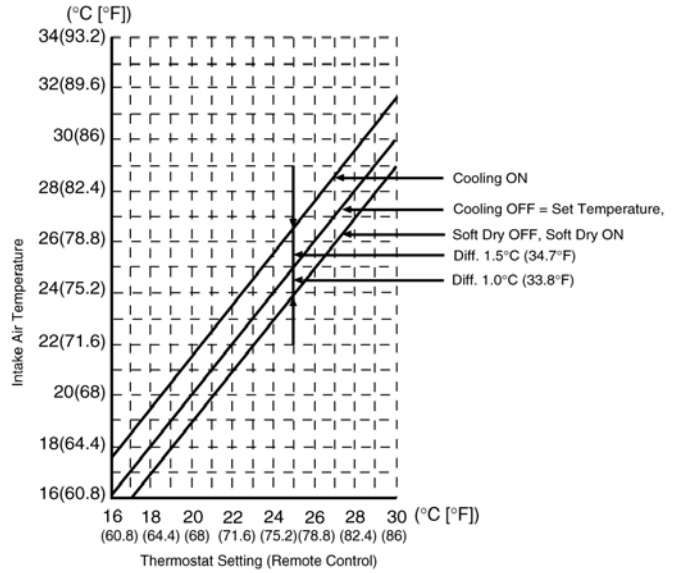

14.2. Operation characteristics

14.2.1. CS-C9DK CU-C9DK

- **Cooling Characteristic**

[Condition] Room temperature: (80.6 / 66.2 °F)
 Cooling operation : At High Fan
 Piping length: 24'7-10/32"

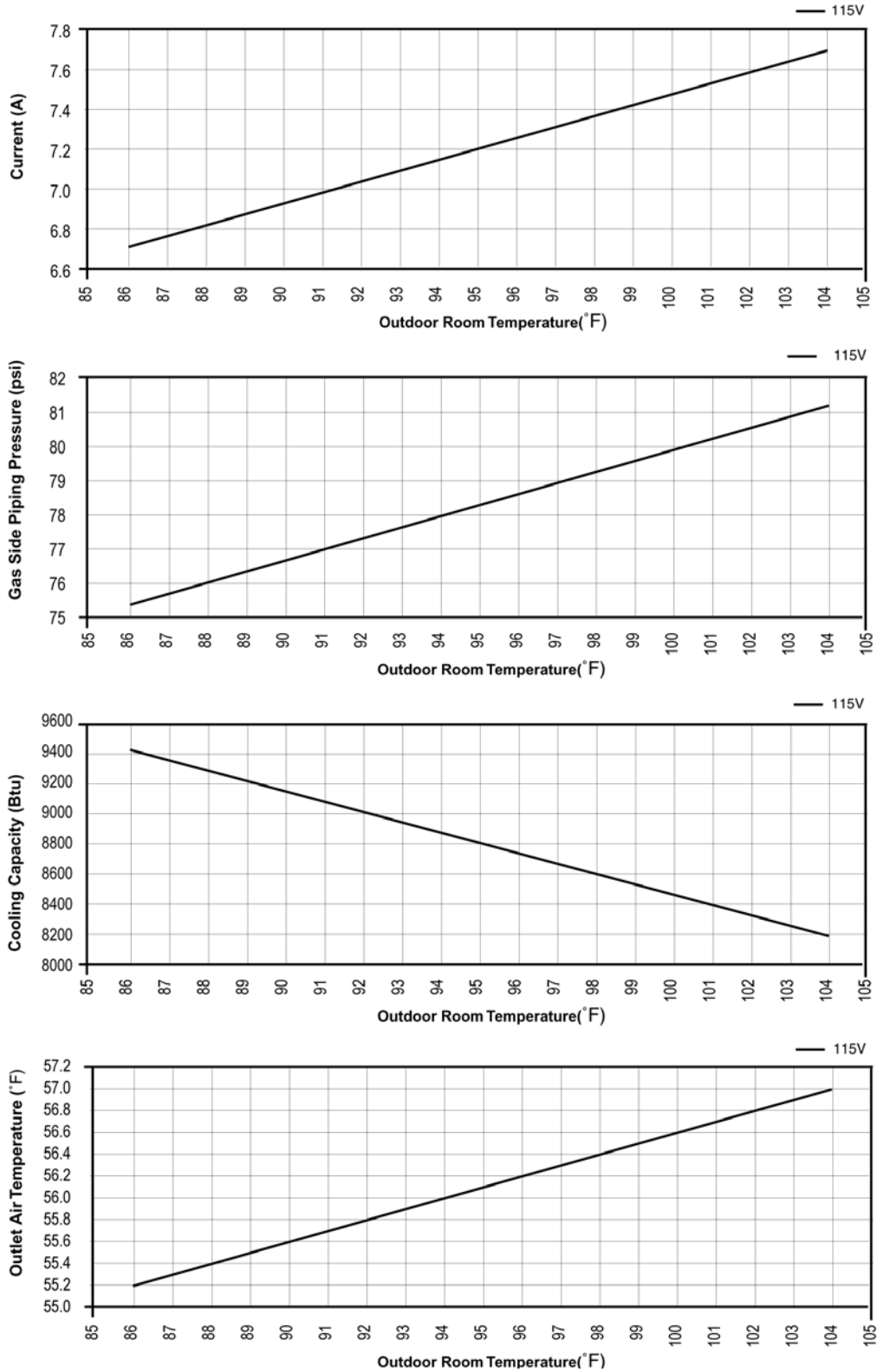

• Piping Length Characteristic

[Condition] Room temperature: (80.6 / 66.2 °F)
 Cooling operation : At High Fan
 Outdoor temperature: 95/75.2 °F

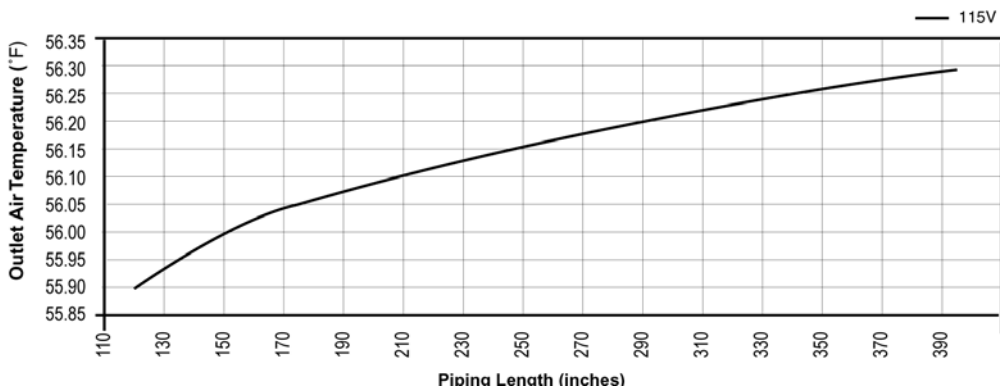
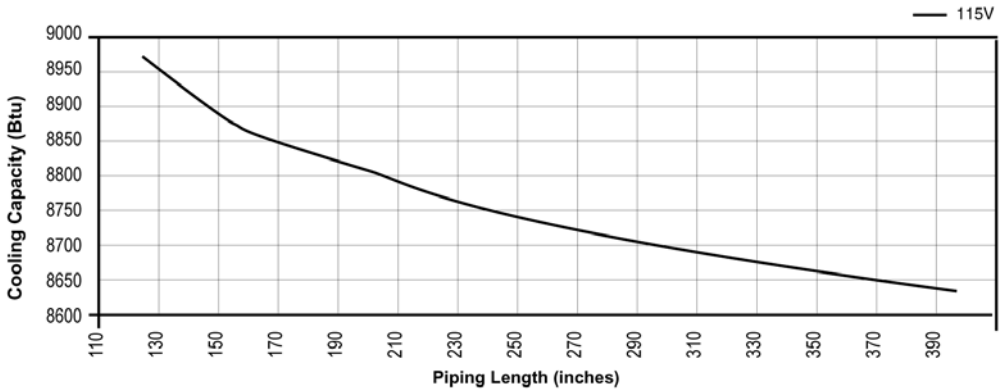
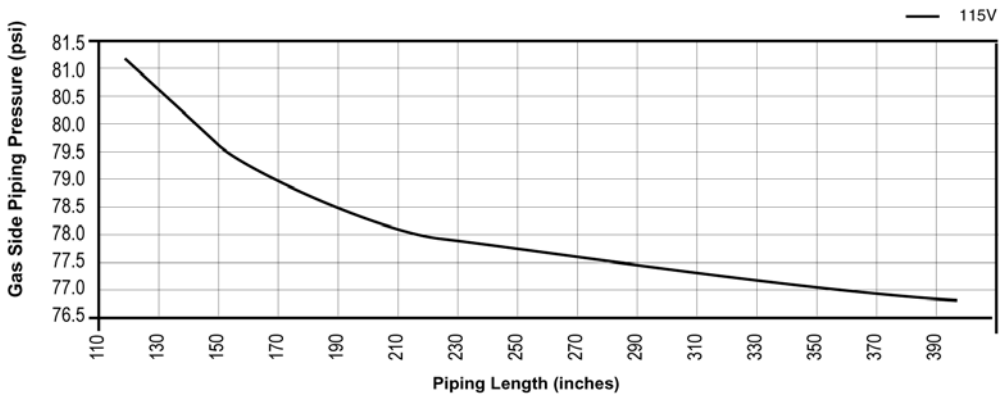
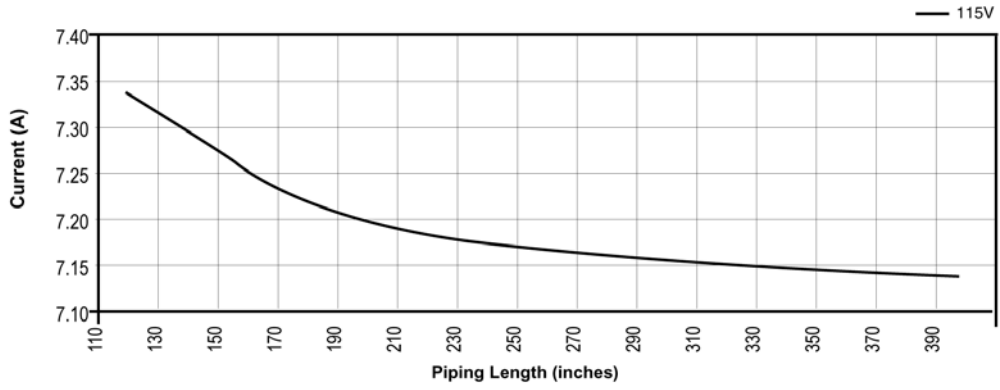

14.2.2. CS-C12DK CU-C12DK

• Cooling Characteristic

[Condition] Room temperature: (80.6 / 66.2 °F)

Cooling operation : At High Fan

Piping length: 24'7-10/32"

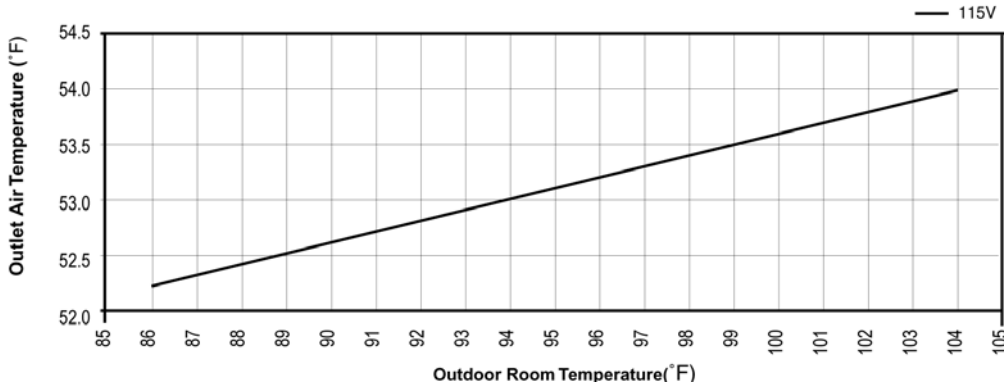
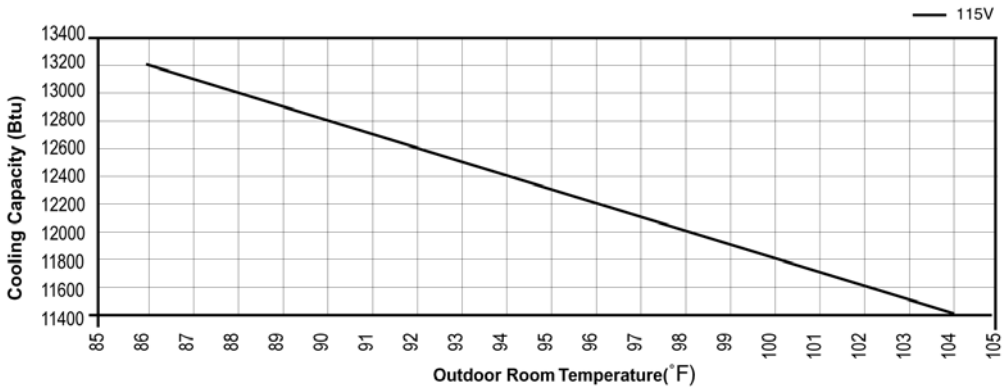
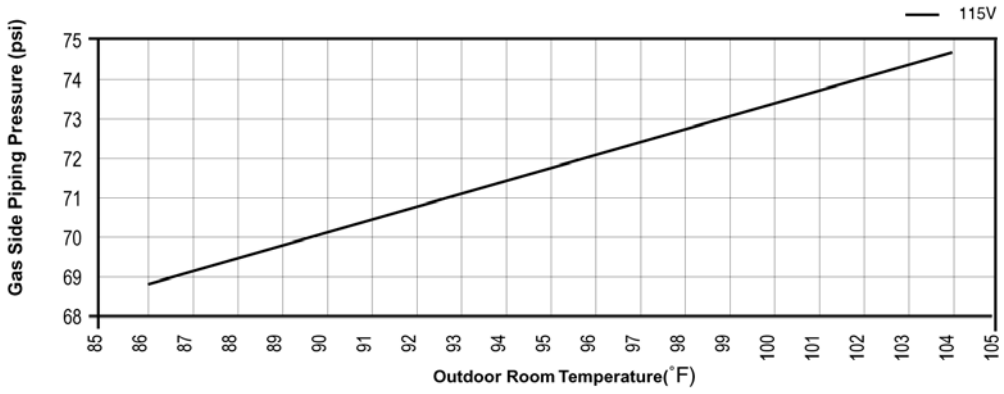
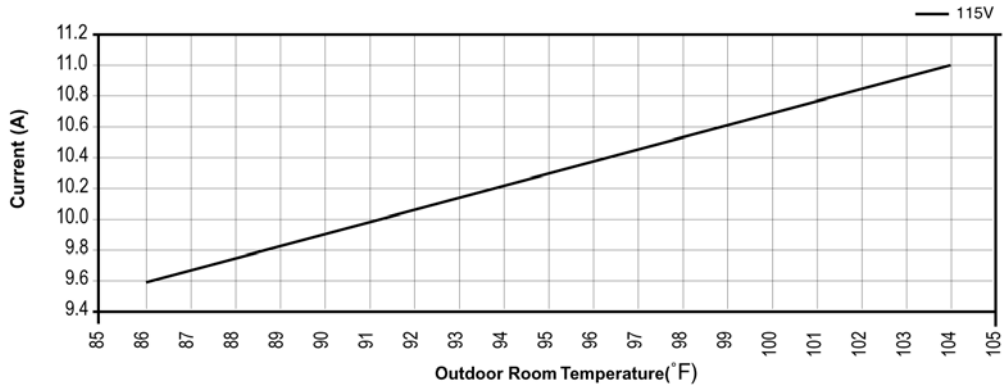

• **Piping Length Characteristic**

[Condition] Room temperature: (80.6 / 66.2 °F)
 Cooling operation : At High Fan
 Outdoor temperature: 95/75.2°F

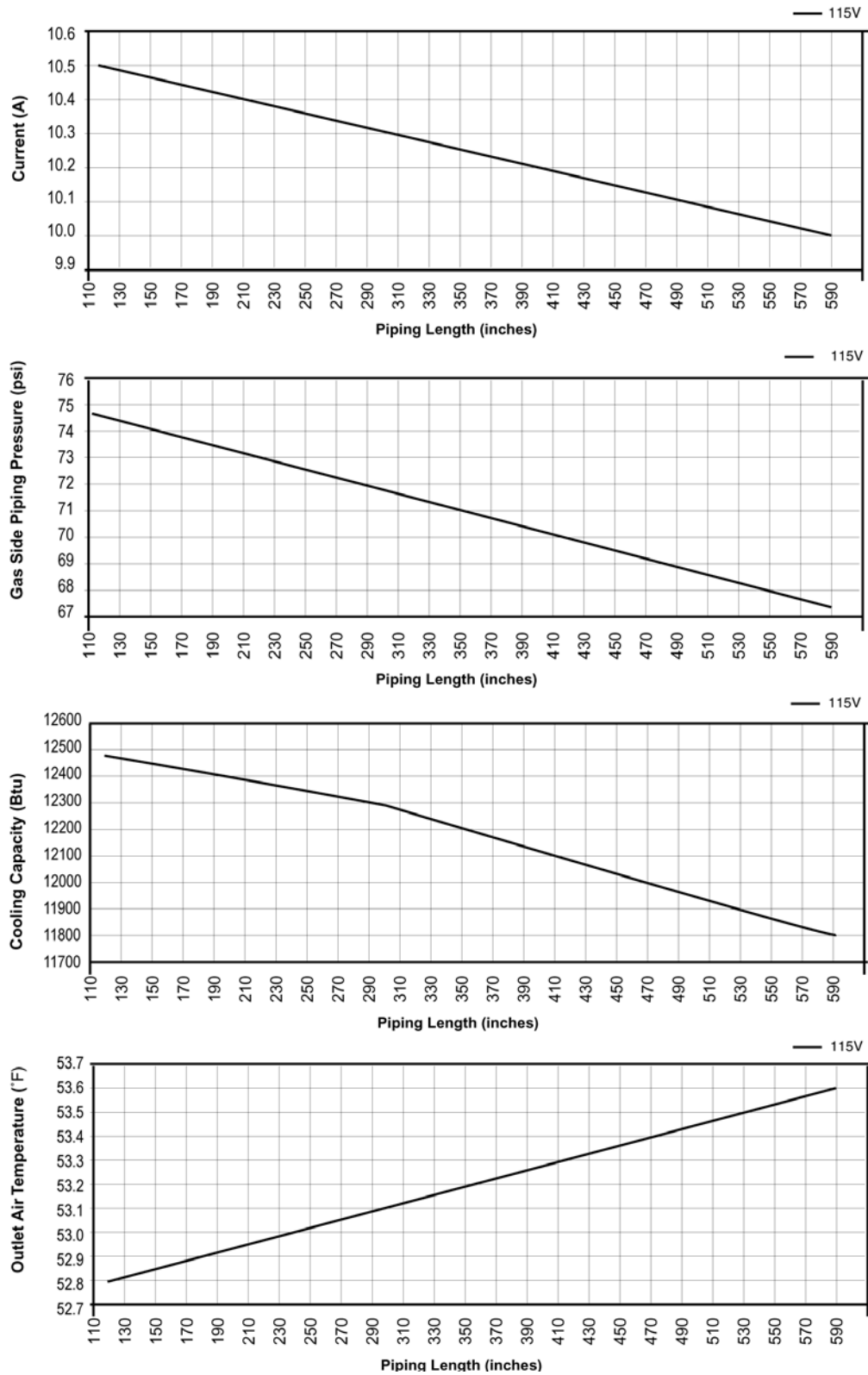

15 Exploded View (Indoor Unit)

CS-C9DKU
CS-C12DKU

- | | | | | | |
|-----------|---|---|---|---|---|
| CWH55025A | ⬆ | ⬆ | ⬆ | ⬆ | ⬆ |
| CWH55051A | ⬆ | ⬆ | ⬆ | ⬆ | ⬆ |

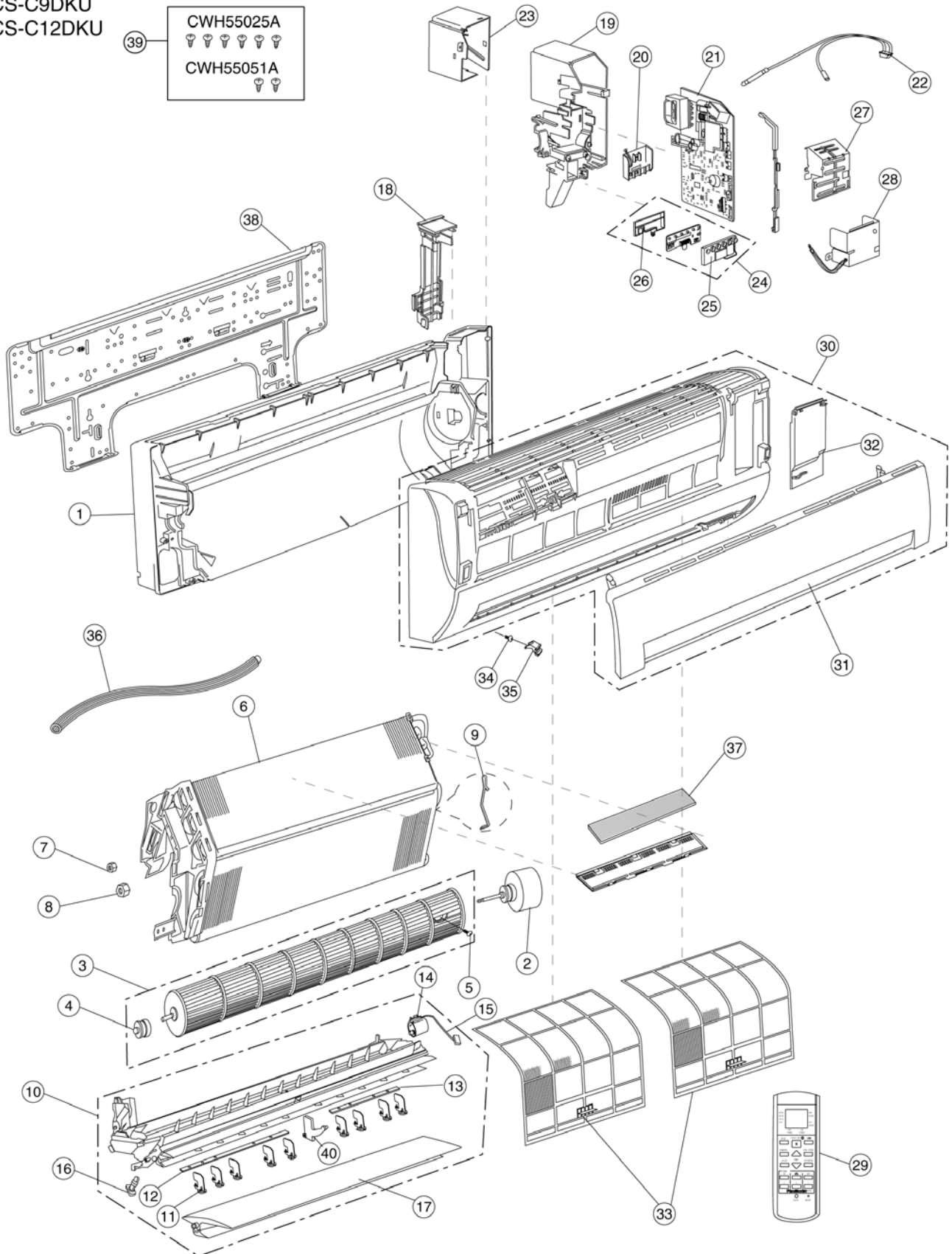

Note:

The above exploded view is for the purpose of parts disassembly and replacement.
The non-numbered parts are not kept as standard service parts.

16 Replacement Parts List (Indoor Unit)

<Model: CS-C9DKU / CS-C12DKU >

REF. NO.	PART NAME & DESCRIPTION	QTY.	CS-C9DKU	CS-C12DKU	REMARKS
1	CHASSY COMPLETE	1	CWD50C1401	←	0
2	FAN MOTOR, AC15W SINGLE	1	CWA921143	←	0
3	CROSS FLOW FAN COMPLETE	1	CWH02C1031	←	0
4	BEARING ASS'Y	1	CWH64K007	←	0
5	SCREW - CROSS FLOW FAN	1	CWH4580304	←	
6	EVAPORATOR	1	CWB30C1745	CWB30C1746	0
7	FLARE NUT	1	CWT25026 (1/4")	←	
8	FLARE NUT	1	CWT25005 (3/8")	CWT25007 (1/2")	
9	INTAKE AIR SENSOR HOLDER	1	CWH32143	←	
10	DISCHARGE GRILLE COMPLETE	1	CWE20C2342	←	0
11	VERTICAL VANE	9	CWE241150	←	0
12	CONNECTING BAR	1	CWE261066	←	
13	CONNECTING BAR	1	CWE261070	←	
14	AIR SWING MOTOR DC SINGLE 12V 300OHM	1	CWA98260	←	0
15	LEAD WIRE - AIR SWING MOTOR	1	CWA67C3977	←	
16	CAP - DRAIN TRAY	1	CWH521096	←	0
17	HORIZONTAL VANE	1	CWE241173	←	
18	BACK COVER CHASSIS	1	CWD932454	←	
19	CONTROL BOARD CASING	1	CWH102259B	←	
20	TERMINAL BOARD COMPLETE	1	CWA28C2226	←	0
21	ELECTRONIC CONTROLLER - MAIN	1	CWA743706	CWA743707	0
22	SENSOR COMPLETE	1	CWA50C2135	←	0
23	CONTROL BOARD FRONT COVER	1	CWH131207	←	
24	INDICATOR COMPLETE	1	CWE39C1127	←	0
25	INDICATOR HOLDER	1	CWD932429	←	
26	INDICATOR HOLDER	1	CWD932430	←	
27	CONTROL BOARD FRONT COVER	1	CWH13C1120	←	
28	CONTROL BOARD FRONT COVER CO.	1	CWH131245	←	0
29	REMOTE CONTROL COMPLETE	1	CWA75C2598	←	0
30	FRONT GRILLE COMPLETE	1	CWE11C3135	←	0
31	INTAKE GRILLE COMPLETE	1	CWE22C1154	←	0
32	GRILLE DOOR	1	CWE141073	←	
33	AIR FILTER	2	CWD001144	←	0
34	SCREW - FRONT GRILLE	2	XTN4+16C	←	
35	CAP - FRONT GRILLE	2	CWH521109	←	
36	DRAIN HOSE	1	CWH851063	←	
37	SUPER ALLERU BUSTER FILTER	1	CWD00C1141	←	
38	INSTALLATION PLATE	1	CWH361067	←	
39	BAG COMPLETE - INSTALLATION SCREW	1	CWH82C067	←	
40	FULCRUM	1	CWH621046	←	

(Note)

- All parts are supplied from PHAAM, Malaysia (Vendor Code: 061).
- "O" marked parts are recommended to be kept in stock.

17 Exploded View (Outdoor Unit)

CU-C9DK
CU-C12DK

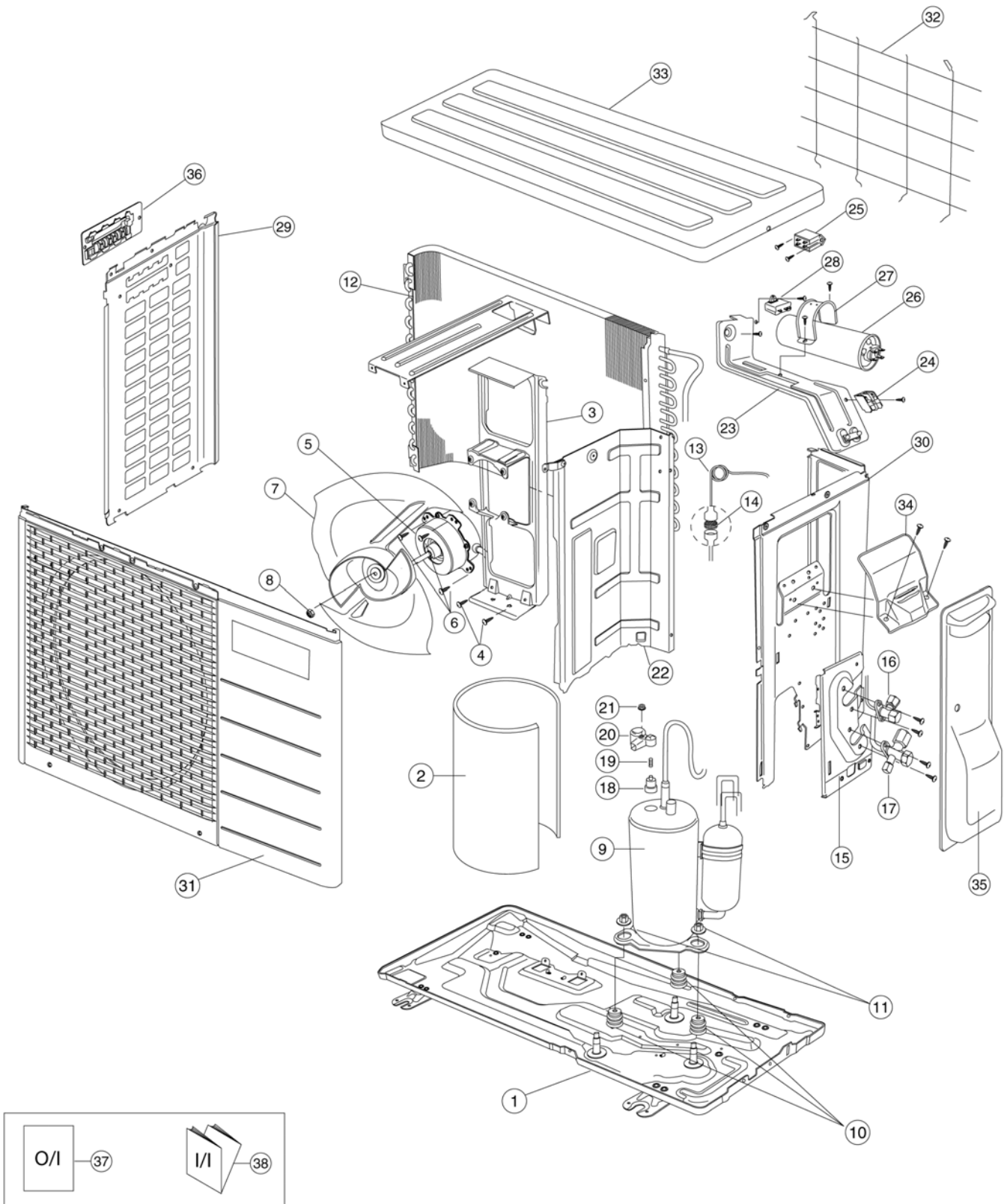

Note:
The above exploded view is for the purpose of parts disassembly and replacement.
The non-numbered parts are not kept as standard service parts.

18 Replacement Parts List (Outdoor Unit)

<Model: CU-C9DKU / CU-C12DKU>

REF. NO.	PART NAME & DESCRIPTION	QTY.	CU-C9DKU	CU-C12DKU	REMARKS
1	CHASSY ASS'Y	1	CWD50K2055A	←	0
2	SOUND PROOF MATERIAL	1	CWG302125	←	
3	FAN MOTOR BRACKET	1	CWD541030	←	
4	SCREW - FAN MOTOR BRACKET	2	CWH551059	←	
5	FAN MOTOR, AC31W SINGLE	1	CWA951244	←	0
6	SCREW - FAN MOTOR MOUNT	3	CWH55406	←	
7	PROPELLER FAN ASS'Y	1	CWH03K1006	←	0
8	NUT - PROPELLER FAN	1	CWH56053	←	
9	COMPRESSOR (60HZ, 115V)	1	2R138126A6AJ	2P19S126C1A	0
10	ANTI - VIBRATION BUSHING	3	CWH50077	←	
11	NUT - COMPRESSOR MOUNT	3	CWH56000	←	
12	CONDENSER	1	CWB32C1291	CWB32C1267	0
13	CAPILLARY TUBE ASS'Y	1	CWB15K1150	CWB15K1151	0
14	STRAINER	1	CWB11025	-	
15	HOLDER COUPLING	1	CWH351015A	←	
16	2-WAY VALVE (LIQUID)	1	CWB021147	←	0
17	3-WAY VALVE (GAS)	1	CWB011147	CWB011148	0
18	OVERLOAD PROTECTOR	1	CWA67C4718	CWA67C4719	
19	HOLDER - O.L.P.	1	CWH7041200	←	0
20	TERMINAL COVER	1	CWH171011	←	
21	NUT - TERMINAL COVER	1	CWH7080300	←	
22	SOUND PROOF BOARD	1	CWH151022A	CWH151023A	
23	CONTROL BOARD CASING	1	CWH102186	-	
24	TERMINAL BOARD ASS'Y	1	CWA28K1123	←	0
25	ELECTRO MAGNETIC SWITCH	1	K6A1ALA00001	←	0
26	CAPACITOR - COMPRESSOR	1	XS371356FP-C (35µF, 370VAC)	XS371506FP-B (50µF, 370VAC)	0
27	HOLDER CAPACITOR	1	CWH30057	CWH30060	
28	CAPACITOR - FAN MOTOR (8.0µF, 230V)	1	JS231805SPQH	←	0
29	CABINET SIDE PLATE (L)	1	CWE041044A	←	0
30	CABINET SIDE PLATE (R)	1	CWE041043A	CWE041073A	0
31	CABINET FRONT PLATE	1	CWE06K1036	←	0
32	WIRE NET COMPLETE	1	CWD04C1010	CWD04C1012	
33	CABINET TOP PLATE	1	CWE031018A	←	
34	CONTROL BOARD COVER	1	CWH131088	←	
35	CONTROL BOARD COVER COMP	1	CWH13C1065	←	
36	HANDLE	1	CWE161010	←	
37	OPERATION INSTRUCTIONS	1	CWF564722	←	0
38	INSTALLATION INSTRUCTIONS	1	CWF612765	←	0

(Note)

- All parts are supplied from PHAAM, Malaysia (Vendor Code: 061).
- "O" marked parts are recommended to be kept in stock.

19 Electronic Circuit Diagram

19.1. Indoor Unit

SCHEMATIC DIAGRAM 1/4

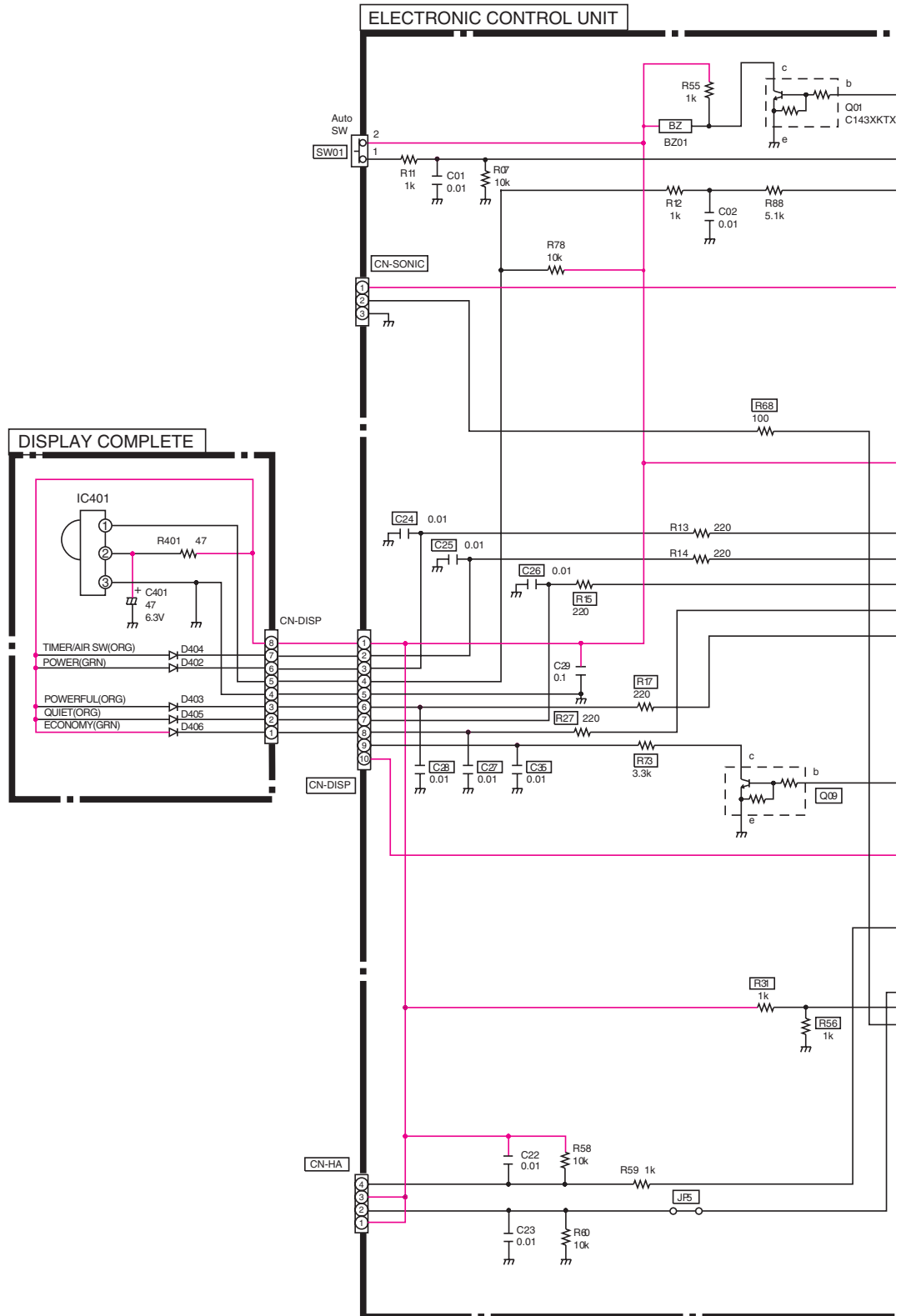

SCHEMATIC DIAGRAM 2/4

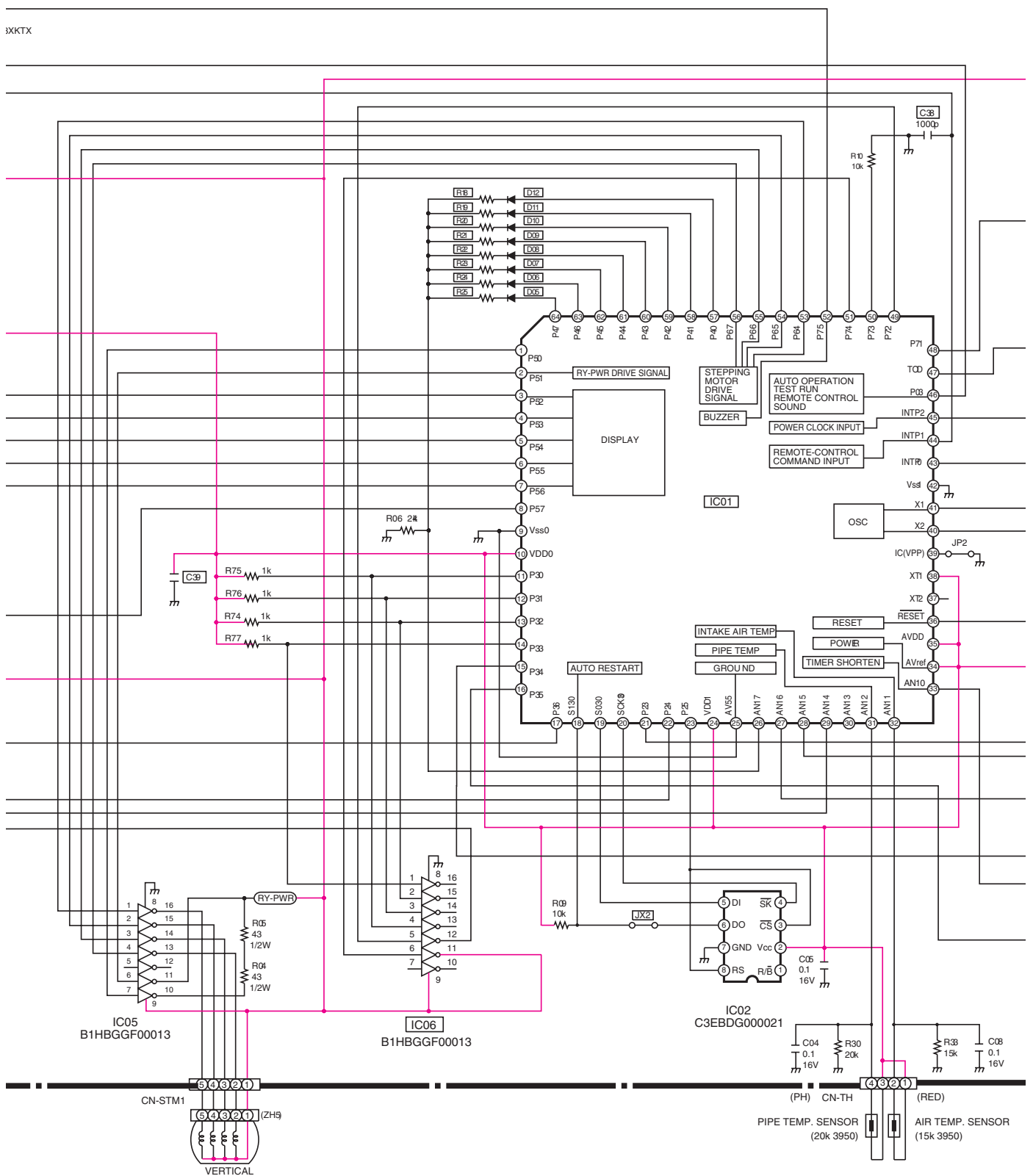

SCHEMATIC DIAGRAM 3/4

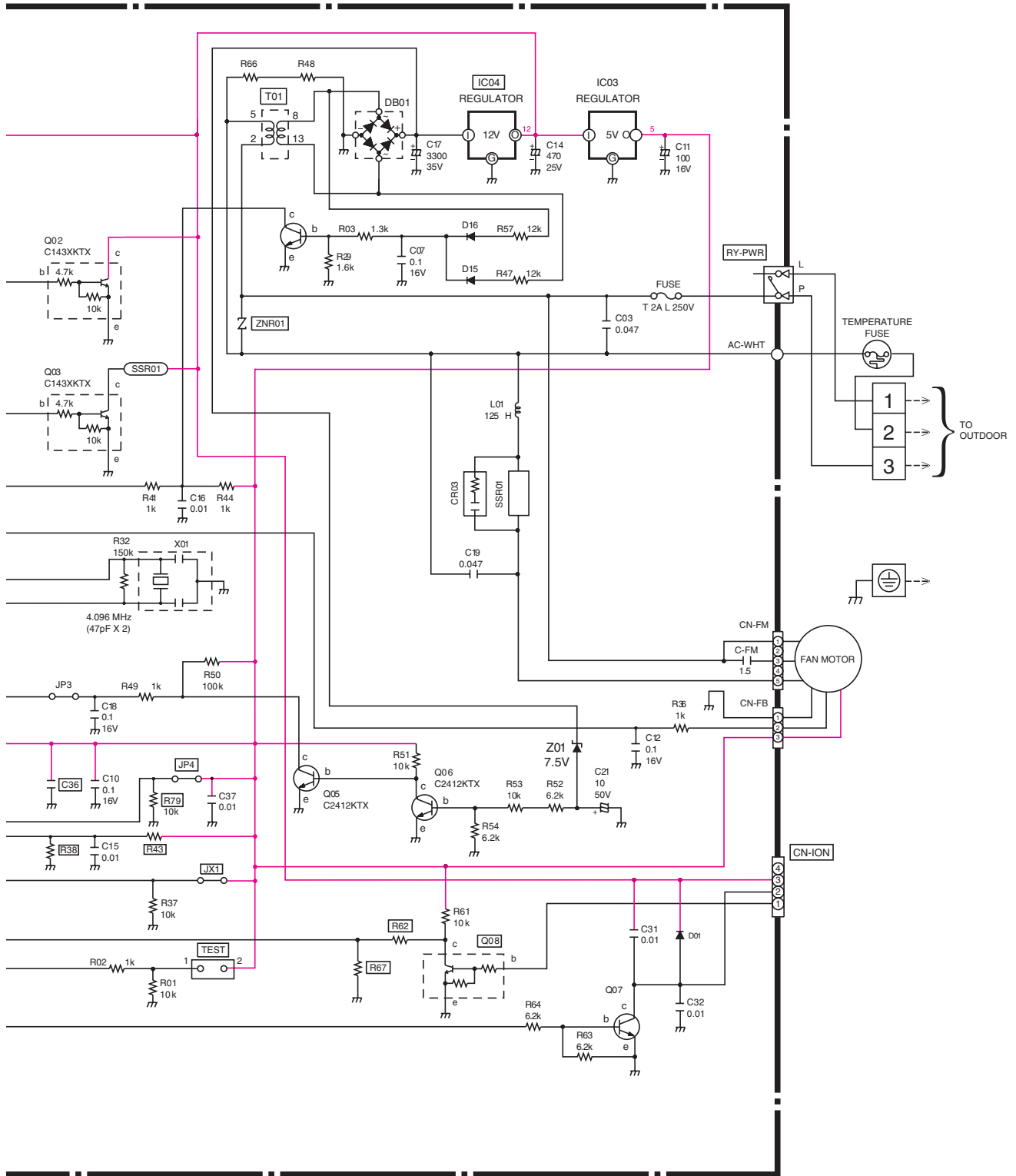

SCHEMATIC DIAGRAM 4/4

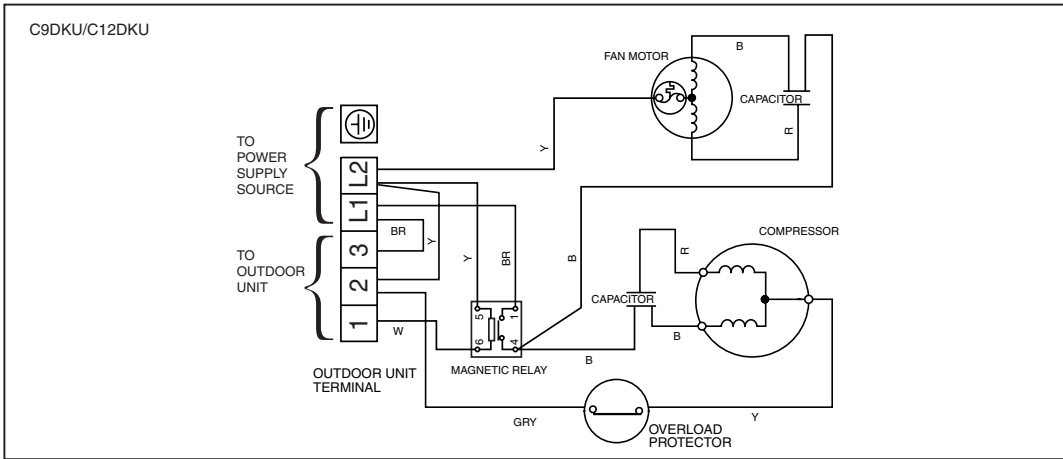

Fig. 1

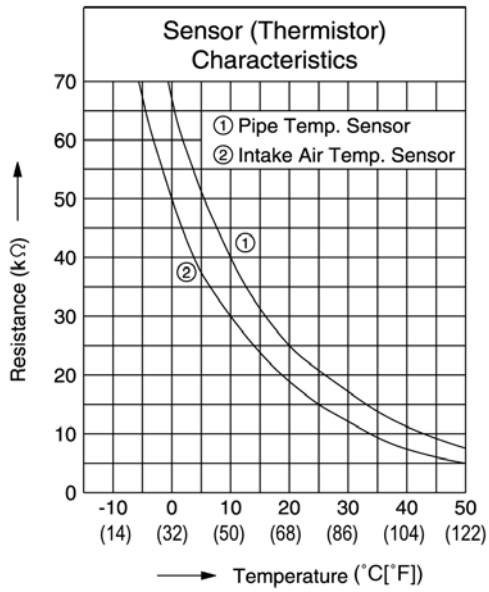

Fig. 2

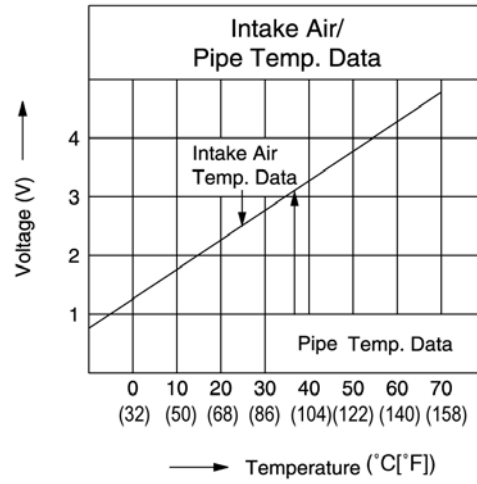
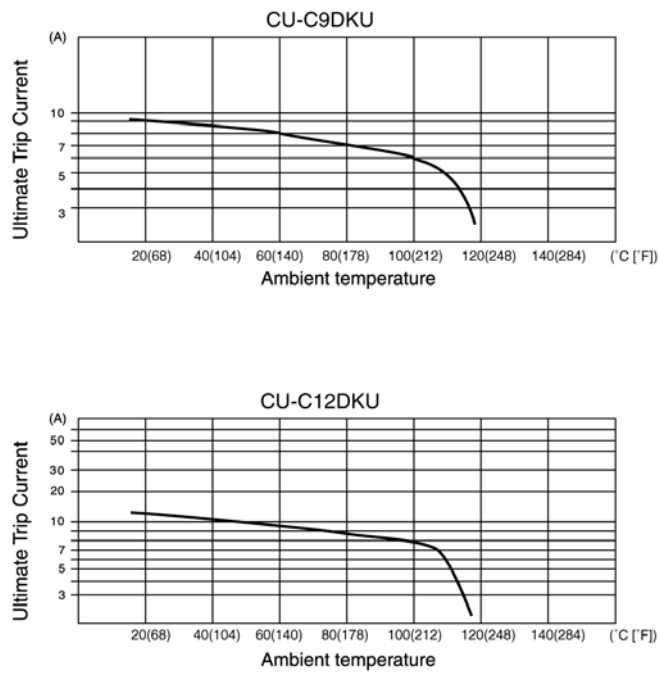

Fig. 3 OLP Characteristics (Compressor)



How to use electronic circuit diagram

Before using the circuit diagram, read the following carefully.

* Voltage measurement

Voltage has been measured with a digital tester when the indoor fan is set at high fan speed under the following conditions without setting the timer.

Use them for servicing.

Voltage indication is in Red at all operations.

	Intake air temperature	Temperature setting	Discharge air temperature	Pipe temperature
Cooling	27°C(80.6°F)	16°C(60.8°F)	17°C(62.6°F)	15°C(59°F)

* Indications for resistance

- a. K...kΩ M...MΩ
W...watt Not indicated....1/4W

b. Type

Not indicated.....carbon resister

Tolerance±5%



.....metal oxide resister

Tolerance±1%

* Indications for capacitor

- a. Unit μ....μF P....pF
b. Type Not indicated....ceramic capacitor
(S).....S series aluminium electrolytic capacitor
(Z).....Z series aluminium electrolytic capacitor
(SU).....SU series aluminium electrolytic capacitor
(P).....P series polyester system
(SXE).....SXE series aluminium electrolytic capacitor
(SRA).....SRA series aluminium electrolytic capacitor
(KME).....KME series aluminium electrolytic capacitor

* Diode without indication.....MA165

* Circuit Diagram is subject to change without notice for further development.

TIMER TABLE

Name		Time	Test Mode (When test point Short-circuited)	Remarks
Real Timer		1 hr.	1 min.	
		10 min.	10 sec.	
		1 min.	1 sec.	
Time Delay Safety Control		2 min. 58 sec.	0 sec.	
Forced Operation		60 sec.	0 sec.	
Time Save Control		7 min.	4.2 sec.	
Anti-Freezing		4 min.	0 sec.	
Auto Mode Judgement		20 sec.	0 sec.	
Soft Dry	OFF	6 min.	36 sec.	
	ON	10 min.	60 sec.	Soft Dry: 10 min. operation
Deodorizing Control	Cooling	40 sec.	4 sec.	
		70 sec.	7 sec.	
		20 sec.	2 sec.	
		180 sec.	18 sec.	
	Soft Dry	40 sec.	4 sec.	
		360 sec.	36 sec.	
Comp. Reverse Rotation Detection		5 min.	30 sec.	Comp. ON 5 min. and above
		2 min.	0 sec.	
Comp./ Fan Motor Delay Timer		1.6 sec.	0 sec.	
Powerful Mode Operation		15 min.	15 sec.	
Random Auto Restart Control		0 ~ 62 sec.	0 ~ 6.2 sec.	

19.2. Remote Control

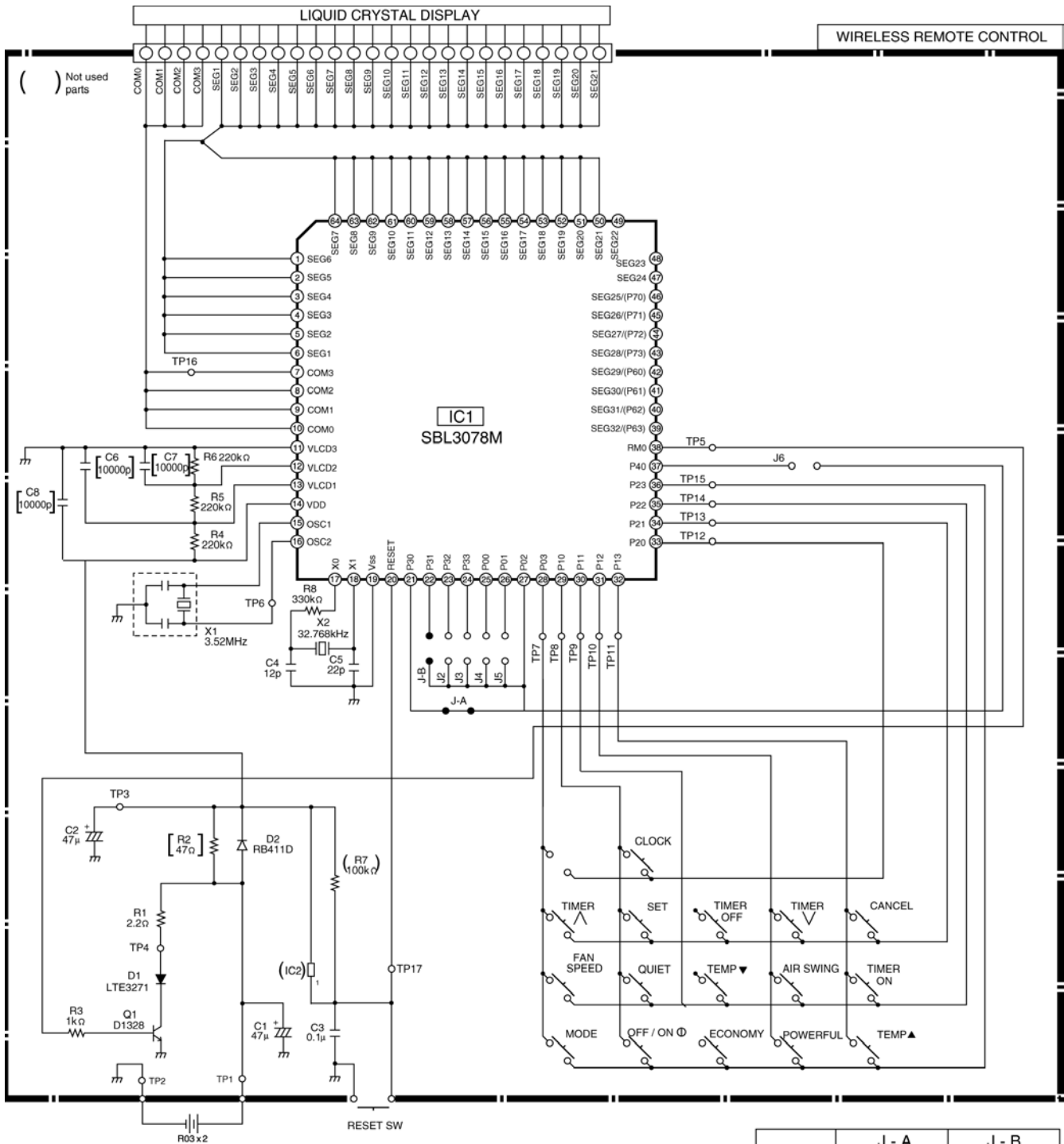

	J - A	J - B
0	SHORT	OPEN
1	OPEN	OPEN
2	SHORT	SHORT
3	OPEN	SHORT

19.3. Print Pattern Indoor Unit Printed Circuit Board

TOP VIEW

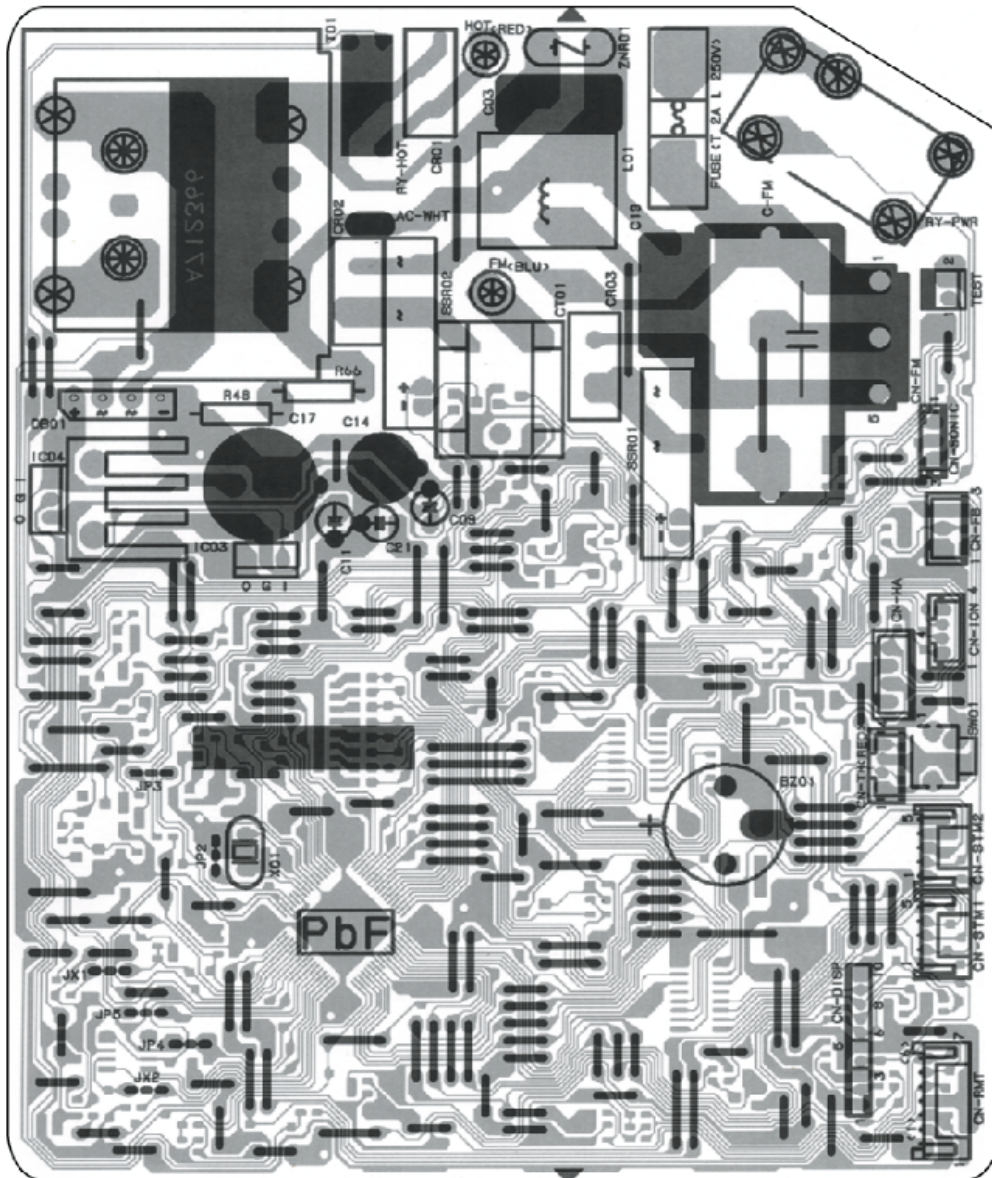

BOTTOM VIEW

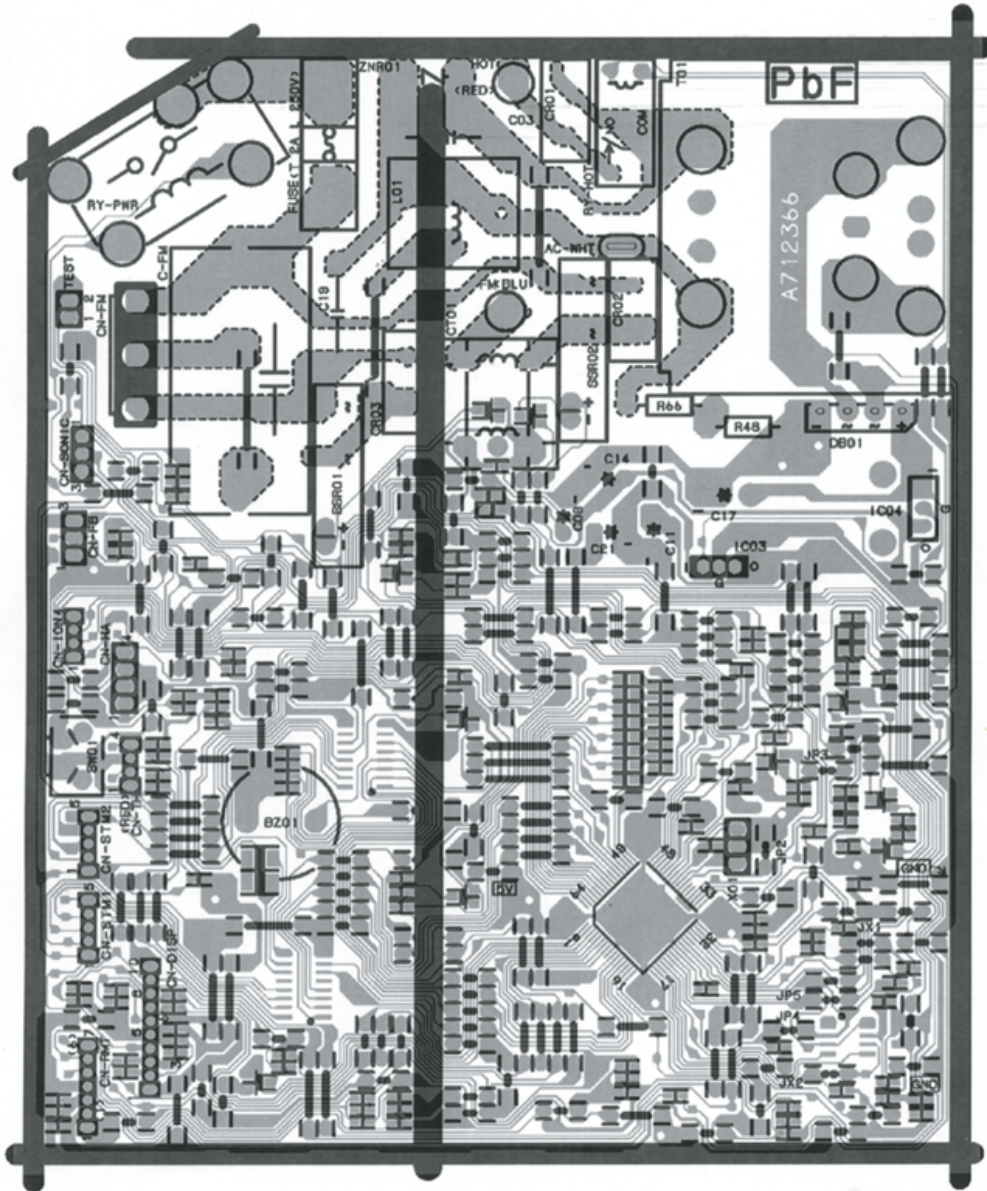

Indicator Printed Circuit Board

TOP VIEW

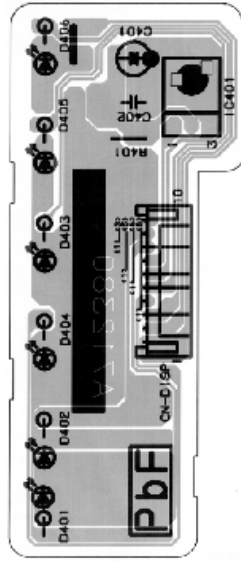

BOTTOM VIEW

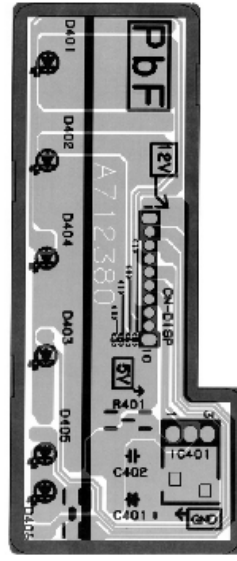

Free Manuals Download Website

<http://myh66.com>

<http://usermanuals.us>

<http://www.somanuals.com>

<http://www.4manuals.cc>

<http://www.manual-lib.com>

<http://www.404manual.com>

<http://www.luxmanual.com>

<http://aubethermostatmanual.com>

Golf course search by state

<http://golfingnear.com>

Email search by domain

<http://emailbydomain.com>

Auto manuals search

<http://auto.somanuals.com>

TV manuals search

<http://tv.somanuals.com>