

NICKEL METAL HYDRIDE BATTERIES: INDIVIDUAL DATA SHEET

HHR330APH Cylindrical L-Fat A size (HR 18/67)

Dimensions (with Tube) (mm)

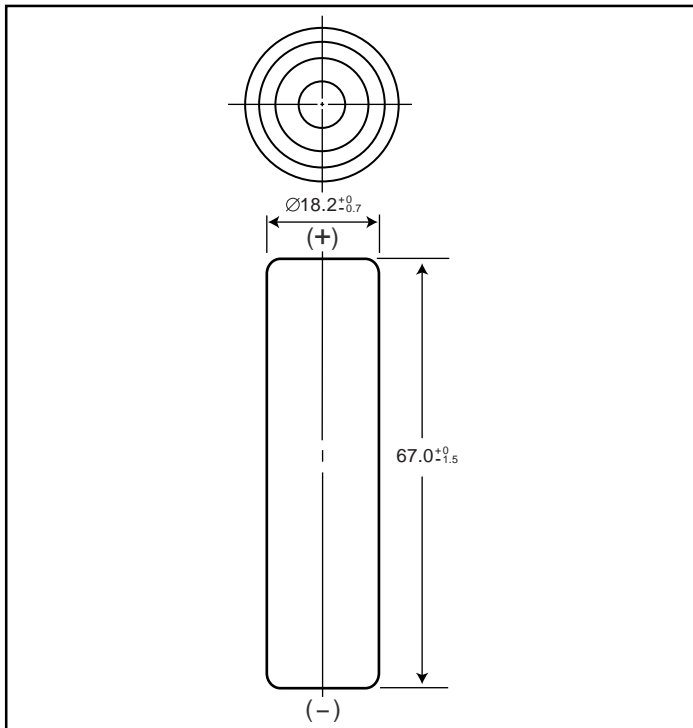

Specifications

	mm	inch
Diameter	18.2+0/-0.7	0.72+0/-0.03
Height	67.0+0/-1.5	2.64+0/-0.06
Approximate Weight	Grams	Ounces
	60	2.12

Nominal Voltage		1.2V		
Discharge Capacity¹	Average²	3300 mAh		
	Rated (Min.)	3200 mAh		
Approx. Internal impedance at 1000Hz at charged state.		5.5mΩ		
Charge	Standard	330mA x 16hrs.		
	Rapid³	1650mA x 2.4 hrs. ⁴		
	Low Rate	165mA x 32 hrs. 110mA x 48 hrs.		
Ambient Temperature	Charge	Standard	°C	°F
			-10°C to 60°C	14°F to 140°F
	Rapid	-10°C to 45°C	14°F to 113°F	
		Discharge	-10°C to 60°C	14°F to 140°F
	Storage	< 1 year	-20°C to 35°C	-4°F to 95°F
		< 6 months	-20°C to 45°C	-4°F to 113°F
< 1 month		-20°C to 55°C	-4°F to 131°F	
< 1 week		-20°C to 65°C	-4°F to 149°F	

¹ After charging at 0.1It for 16 hours, discharging at 0.2It.

² For reference only.

³ Need specially designed control system

Control System:

dT/dt cut-off; 1 to 2°C/min

-ΔV cut-off; -ΔV per cell = 5 to 10 mV

T-control; T=65°C

Rapid charger timer; 2.4h (at 1.25a)

Trickle timer; within 2h

⁴ With control system

Battery performance and cycle life are strongly affected by how they are used. In order to maximize battery safety, please consult Panasonic when determining charge / discharge specs, warning label contents and unit design.

Typical Charge Characteristics

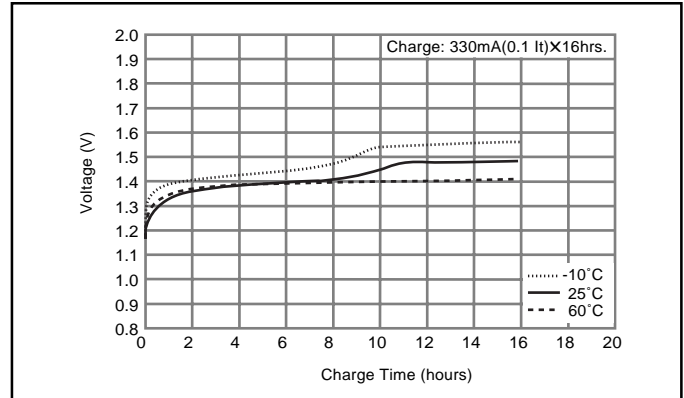

Typical Discharge Characteristics

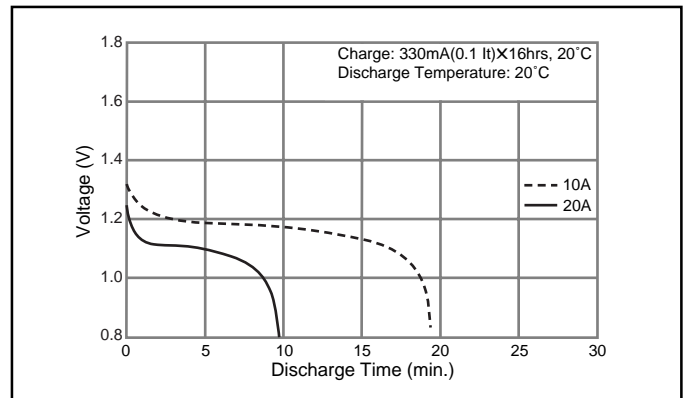
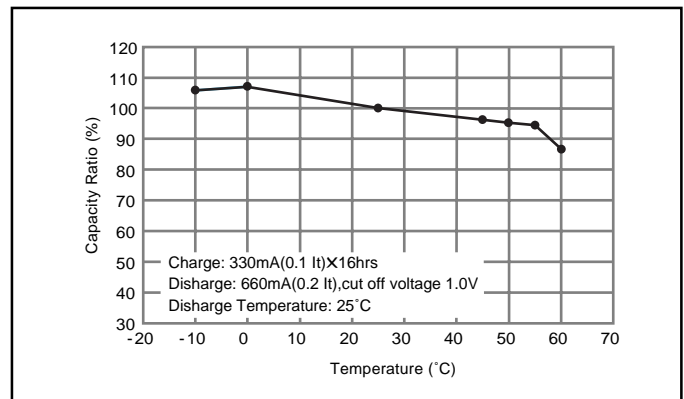

Note: [It] was previously expressed as [C]. [It] is an IEC standard expression for the amount of charge or discharge current and is expressed as:

$$It(A) = Cn (Ah)/1h.$$

- [It] is the reference test current in amperes
- [Cn] is the rated capacity of the cell or battery in Ampere-hours.
n = the time base [hours] for which the rated capacity is declared

Free Manuals Download Website

<http://myh66.com>

<http://usermanuals.us>

<http://www.somanuals.com>

<http://www.4manuals.cc>

<http://www.manual-lib.com>

<http://www.404manual.com>

<http://www.luxmanual.com>

<http://aubethermostatmanual.com>

Golf course search by state

<http://golfingnear.com>

Email search by domain

<http://emailbydomain.com>

Auto manuals search

<http://auto.somanuals.com>

TV manuals search

<http://tv.somanuals.com>