

Panasonic

TELEPHONE ANSWERING
SYSTEM WITH FACSIMILE

MODEL NO. **KX-F220**

Operating Instructions

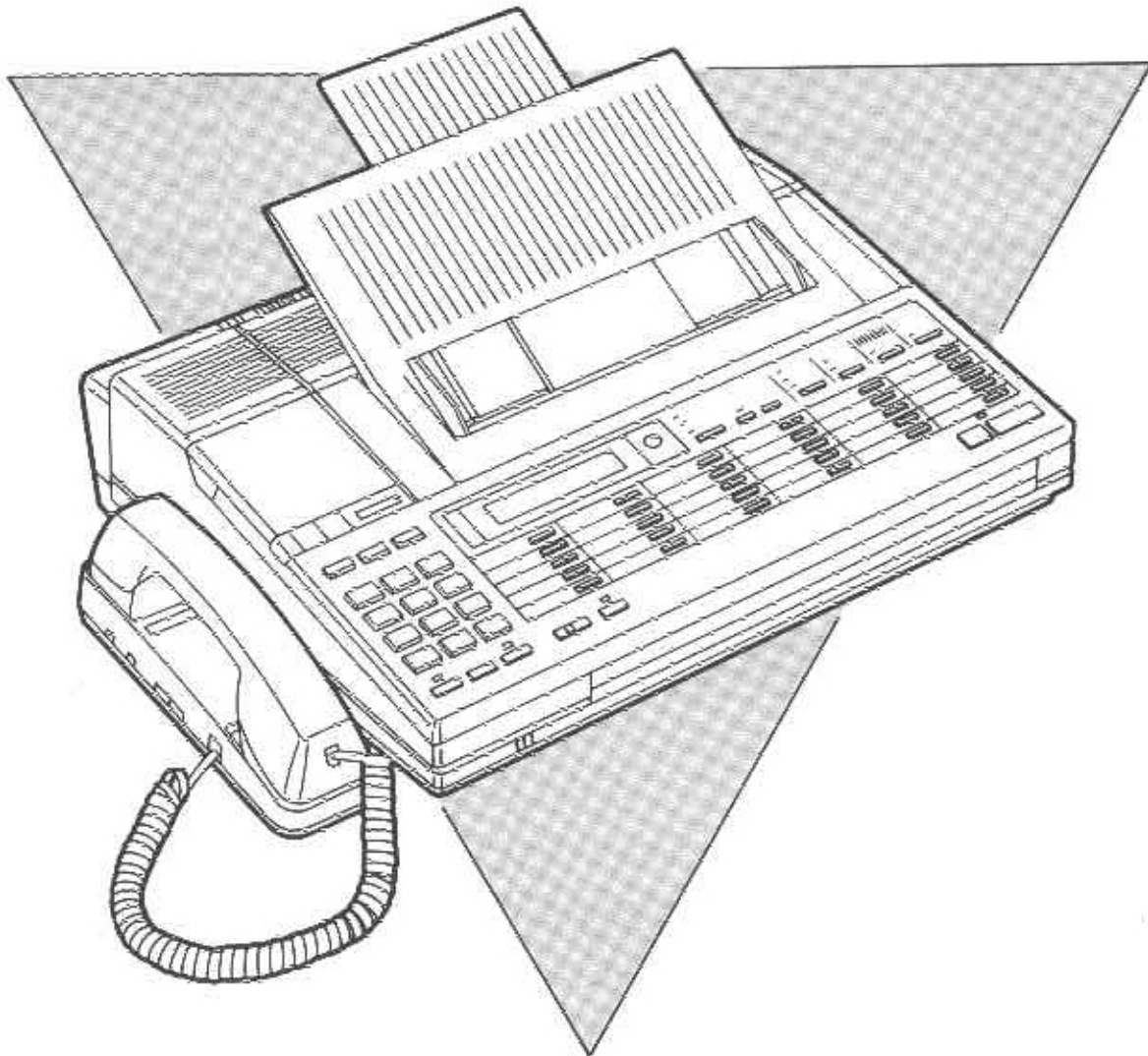

Please read before use.

Thank you for purchasing the Panasonic Telephone Answering System with Facsimile.

Before reading these instructions, please read the *INSTALLATION MANUAL*.

You can then easily install the unit and configure it properly.

Since this unit functions as a Facsimile, an Answering Machine and a Telephone, you can receive both voice-messages and documents utilizing one telephone line.

INTRODUCTION

Multi-function system utilizing a single telephone line:

- Allows you to speak with a caller and/or receive a document.
- Automatically receive a document during your absence and/or records a caller's voice-message.

Facsimile:

- CCITT G II/G III communication compatibility
- Transmission time*: Approx. 17 sec./page
- Automatic document feeder up to 15 pages at a time
- Automatic paper cutter
- One-Touch transmission with automatic dialer
- Polling functions
- Delayed communications
- Password communications
- 16-step HALF-TONE feature for originals containing photographs, shaded drawings, etc.
- Superb image quality
- Up to letter size (8½"×11") transmission

Answering Machine:

- **AUTO-LOGIC**
Automatically plays back all the recorded messages, stopping at the last message: provides for answering the next phone call at the touch of a button.
- Time/Day stamp
- Recording a 2-Way telephone conversation
- Recordable OGM chip
- Beeperless remote control with touch-tone telephone

Integrated Telephone System:

- Built-in speakerphone
- One-touch dialing and Speed dialing
- Automatic redialing

Copier Function:

- Clear copy of up to 15 pages

※ Transmission time

Transmission times apply to next date using CCITT No. 1 test chart, between same machine models at maximum modem speed. Transmission times vary in actual usage.

Setting Auto Receiving Mode:

1. Record your Outgoing Message.
2. Set the FUNCTION selector to the ANS/FAX position.
3. Press the AUTO RECEIVE button.
 - The AUTO RECEIVE indicator will light.
 - When a call is received, the unit will record a voice-message and/or receive a document.
 - In this mode, you may speak with the other party and transmit/receive a document manually.

Setting Manual Receiving Mode:

1. Press AUTO RECEIVE button.
 - The AUTO RECEIVE indicator will go out.

FUNCTION Selector:

■ ANS/FAX position

When you use the unit as an answering machine and a facsimile in the Auto Receiving mode, set to the ANS/FAX position.

The unit will automatically switch between an answering machine and a facsimile.

If the caller's voice is not heard within 5 seconds of the end of your Outgoing Message (OGM), the unit will switch itself to the facsimile mode to receive a document.

If the caller's voice is heard, the unit will function as an answering machine.

■ FAX position

When you use the unit as a facsimile machine only in the Auto Receiving mode, set to the FAX position.

When a call is received, the unit will function as a facsimile machine only.

Speaking with the Other Party, and then Transmitting/Receiving a Document

With the automatic telephone/facsimile switching feature, you can switch between telephone and facsimile functions without redialing.

So, if you are in the middle of a conversation and want to transmit/receive a document, simply press the START/COPY button. Then facsimile transmission/reception will take place automatically.

Recording a Voice-Message and Receiving a Document

The unit will automatically function as an answering machine or a facsimile depending on the caller's choice.

When a call is received during your absence, the unit will play your Outgoing Message (OGM), and then be ready to record a voice-message and/or receive a document (Auto Receiving Mode).

In this mode, you may speak with the other party and transmit/receive a document manually.

TABLE OF CONTENTS

Before Using the Unit

LOCATION OF CONTROLS	7
HOW TO READ THESE OPERATING INSTRUCTIONS	11
SYSTEM SET UP	12
•Printing "SYSTEM SET UP LIST"	12
•Programming Date and Time	15

Manual Communications

MANUAL DIALING	16
•Making a Call	16
•Receiving a Call	17
•Redialing for Manual Dialing	17
MANUAL TRANSMISSION AND RECEPTION	18
•Manual Transmission	18
•Manual Reception	19

How to Operate as a Facsimile Machine

BEFORE TRANSMITTING A DOCUMENT	1-1
•Transmissible Document	1-1
•Using the Carrier Sheet	1-2
TRANSMITTING A DOCUMENT	1-4
•Manual Transmission	1-4
•When Using One-Touch Dialing	1-5
•When Using Speed Dialing	1-6
•Transmitting Reservation	1-7
•Redialing for One-Touch and Speed Dialing	1-8
•Setting Delayed Transmission	1-9
RECEIVING A DOCUMENT AND/OR VOICE-MESSAGE	1-11
•Manual Reception	1-11
•Explanation of Auto Receiving Mode	1-12
•Receiving Voice-Messages and a Document Automatically (Using as an Answering and a Facsimile Machine)	1-12
•Receiving a Document Automatically (Using as a Facsimile Machine)	1-13
•Cancelling Auto Receiving Mode	1-13
•Setting Auto Receiving Mode Remotely	1-13
TRANSMITTING TO YOUR KX-F220 FROM A REMOTE LOCATION	1-14
•Recording Your Message and Transmitting a Document	1-14
•Transmitting a Document Only	1-14

VOICE CONTACT	1-15
• <i>Initiating Voice Contact During Transmission/</i>	
<i>Reception</i>	1-15
• <i>Receiving a Request for Voice Contact</i>	1-15
SETTING "PAGE COUNTER"	1-16
REMOTE FAX ID	1-17
• <i>Setting Remote FAX ID</i>	1-17
• <i>Transmitting a Document with Remote Fax ID to your</i>	
<i>KX-F220 from a Remote Location</i>	1-18
SETTING THE "MESSAGE OUT"	1-19
TURNING ON/OFF THE AUTO RECEIVING MODE	1-21
POLLING	1-23
• <i>Programming the Polling Password</i>	1-23
• <i>Preparation for Being Polled</i>	1-24
• <i>Single Station Polling</i>	1-25
• <i>Multi Station Polling</i>	1-27
• <i>Turnaround Polling</i>	1-29
• <i>Delayed Polling</i>	1-31
• <i>Delayed Turnaround Polling</i>	1-33
PROGRAMMING AUTOMATIC DIALING NUMBERS	1-35
• <i>Programming One-Touch Dialing Numbers</i>	1-35
• <i>Programming Speed Dialing Numbers</i>	1-37
• <i>Programming as Secret Phone Numbers</i>	1-39
USING THE PRIORITY BUTTONS	1-41
• <i>Programming Flowchart</i>	1-42
• <i>Programming Delayed XMT (Transmission)</i>	1-43
• <i>Programming POLL (Single Polling)</i>	1-44
• <i>Programming POLL (Multi Polling)</i>	1-45
• <i>Programming XMT & POLL (Turnaround Polling)</i>	1-47
• <i>Calling with Priority Buttons</i>	1-48
PASSWORD COMMUNICATIONS	1-50
• <i>Information of the Password Communications</i>	1-51
• <i>Programming the Password Communications</i>	1-53
• <i>Password Communications</i>	1-55
• <i>Programming Different Passwords into Priority</i>	
<i>Buttons</i>	1-56
PRINTING REPORTS AND LISTS	1-57
• <i>Activity Report (JOURNAL Report)</i>	1-57
• <i>Setting JOURNAL Report</i>	1-58
• <i>Printing a JOURNAL</i>	1-59
• <i>List of Multi Polling</i>	1-59
• <i>System Set Up List</i>	1-60
• <i>Printing System Set Up List</i>	1-60
• <i>List of Stored Phone Numbers (TEL LIST)</i>	1-61
• <i>Printing a List of Stored Phone Numbers (TEL LIST)</i> ..	1-62
• <i>Individual Transmission Report (XMT Report)</i>	1-63
• <i>Setting XMT Report</i>	1-63
MAKING COPIES	1-65
• <i>Making Copies</i>	1-65
• <i>Interrupting Copies</i>	1-65

TABLE OF CONTENTS (CONT.)

How to Operate as an Answering Machine

PREPARING THE ANSWERING MACHINE.....2-1

- Recording an Outgoing Message (OGM)2-1
- Setting Up for Receiving Voice-Messages and a Document (Using as an Answering Machine and a Facsimile)2-2
- Voice Time/Day Stamp2-2
- Programming an ATAS ID for Remote Operation2-3
- Programming a Caller's Recording Time2-4

OPERATING THE ANSWERING MACHINE.....2-5

- Fast Forwarding Tape2-5
- Resetting (Rewinding) Tape2-5
- Call Counter2-5
- Erasing Recorded Messages2-6
- Playing Back Recorded Voice-Messages2-6
- Stopping Tape (Pause mode)2-6
- Recording a Message Memo2-7
- Recording a 2-Way Conversation (2-Way Recording)2-8
- Saving Recorded Messages.....2-9
- Monitoring Incoming Calls2-9

HOW TO OPERATE FROM A REMOTE PHONE.....2-10

- Summary of Remote Control Functions2-10
- Playing Back Messages2-11
- Playing Back Newly-Recorded Messages (Memory Playback).....2-11
- Back Space and Skip Forward.....2-11
- Resetting Tape for Future Messages2-12
- Recording a Marker Message2-13
- Turning On the Speakerphone (Answer Back)2-13
- Re-Recording the Outgoing Message.....2-14
- Skipping the OGM for ICM Recording.....2-14
- Turning On the Auto Receiving Mode2-15

How to Operate as a Telephone

MAKING AND RECEIVING A CALL	3-1
• <i>Making a Call</i>	3-1
• <i>Receiving a Call</i>	3-2
• <i>Redialing</i>	3-2
SWITCHING TO HANDS-FREE OR HANDSET OPERATION DURING A CONVERSATION	3-3
• <i>Handset to Hands-Free</i>	3-3
• <i>Hands-Free to Handset</i>	3-3
OTHER FEATURES	3-4
• <i>Mute Operation</i>	3-4
• <i>Flash Button (Accessing to PBX)</i>	3-4
• <i>Tone Button Dialing</i>	3-4
• <i>Combination Dialing</i>	3-4
• <i>Outside Line or Computer Accessed Line (Pause Button)</i>	3-5

General Informations

TROUBLESHOOTING GUIDE	4-1
RECORDING PAPER INSTALLATION	4-5
DOCUMENT TRAY INSTALLATION	4-7
SYSTEM PROGRAMMING FUNCTIONS	4-9
• <i>CPC MODE</i>	4-9
• <i>AUX. LEADS</i>	4-10
• <i>DIAL PULSE</i>	4-11
• <i>TONE DETECT</i>	4-12
• <i>TX SPEED</i>	4-13
• <i>RX SPEED</i>	4-14
• <i>STAMP DEFAULT</i>	4-15
• <i>AUTO STANDBY</i>	4-16
• <i>SET DEFAULT</i>	4-17
• <i>TEST [PRINT OR MOTOR]</i>	4-17
INDEX	4-18

LOCATION OF CONTROLS

For Document tray installation, see pages 4-7 to 4-8.

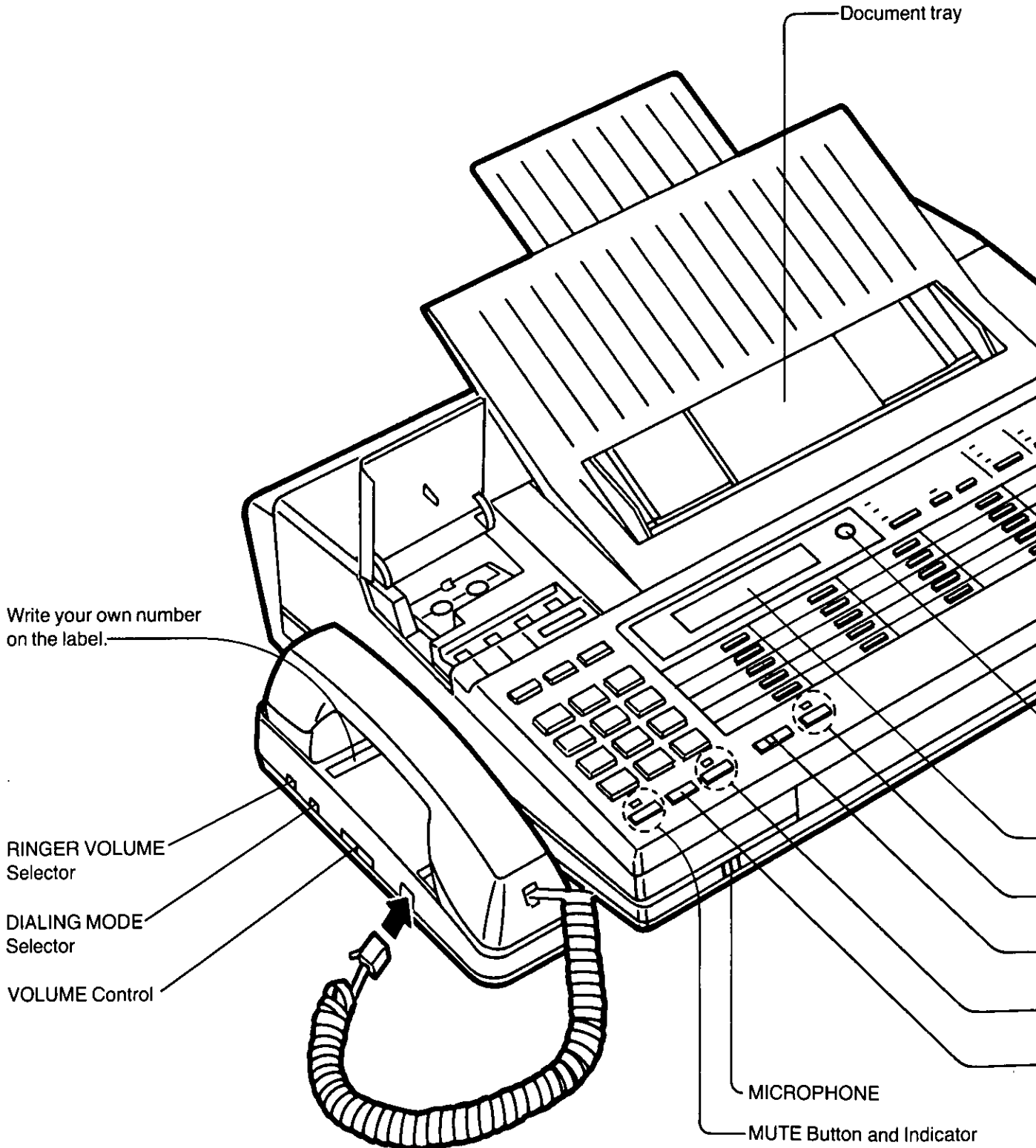

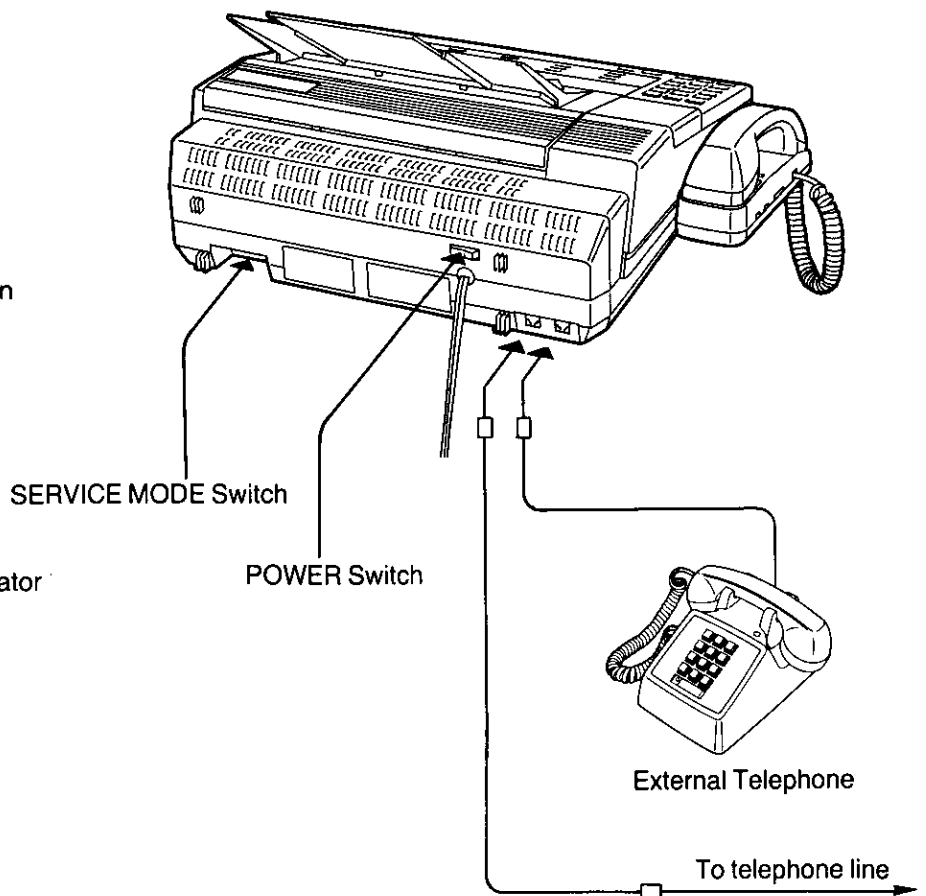
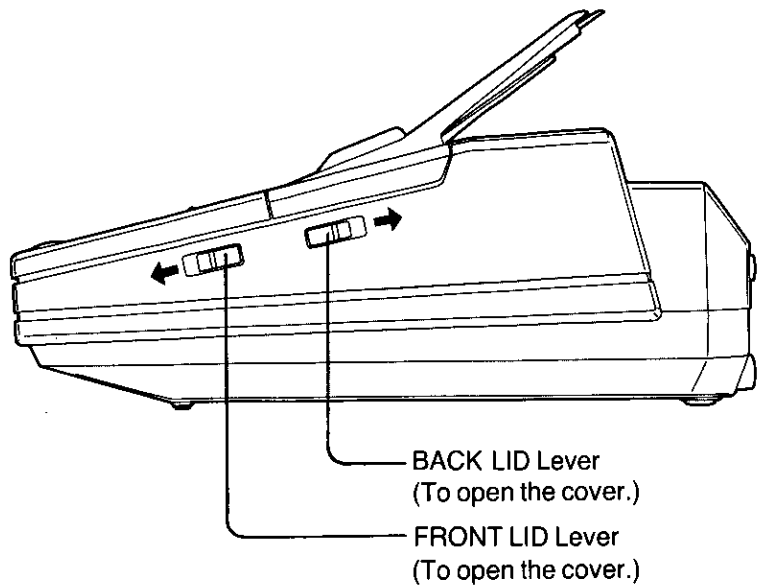
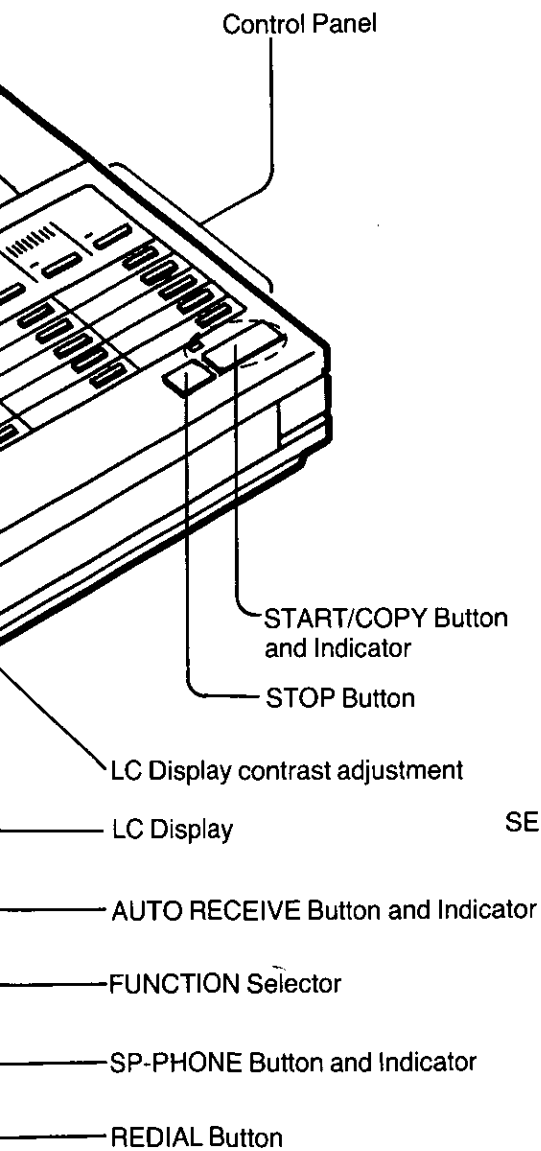

LOCATION OF CONTROLS (CONT.)

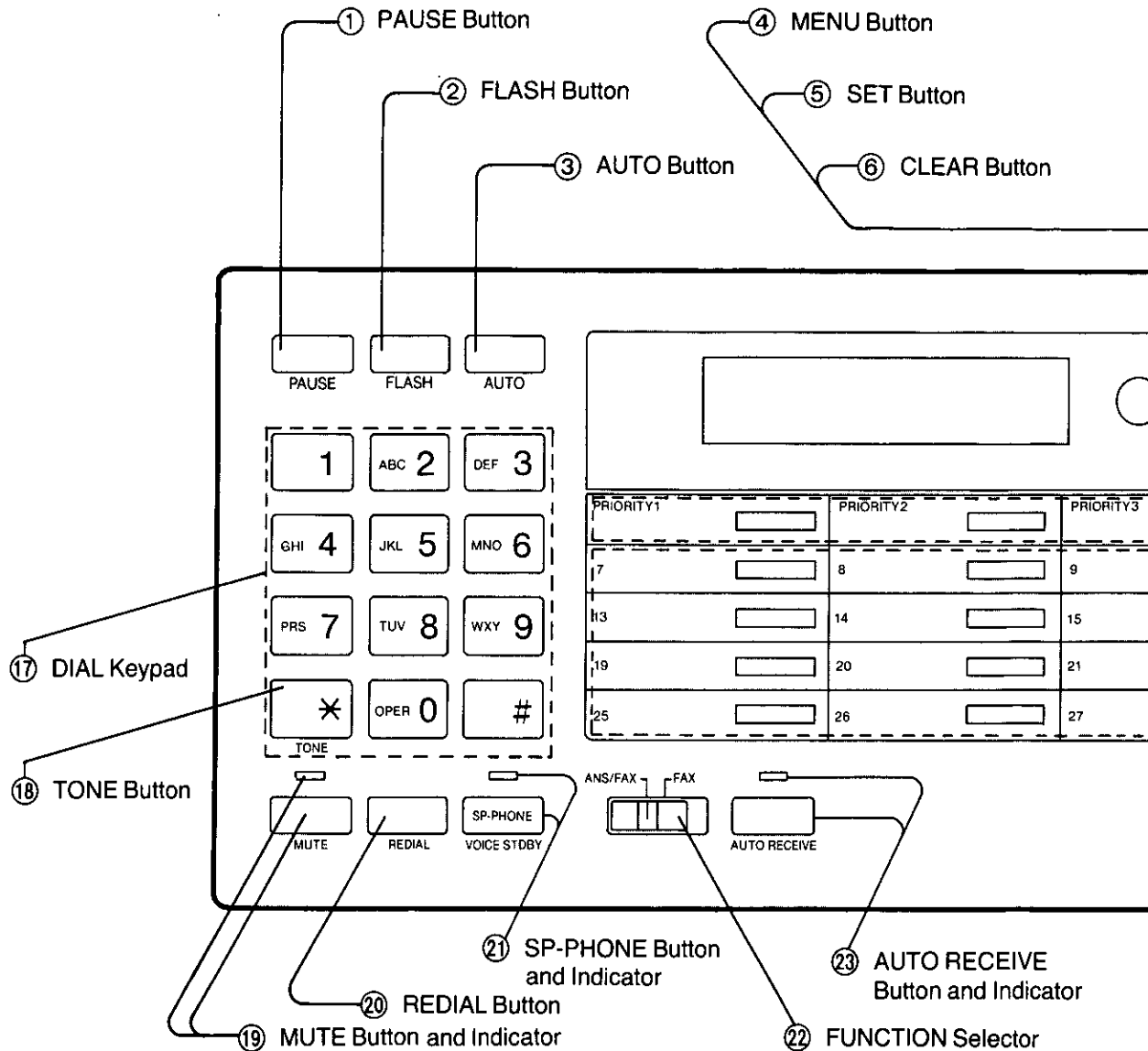

① **PAUSE Button:**
Press to enter a pause in facsimile/telephone numbers when programming.

② **FLASH Button:**
Used to access some of the features of your host PBX.

③ **AUTO Button:**
Used for speed dialing.

④ **MENU Button:**
Used to start XMT RESERVATION, DELAYED XMT, POLLING, SYSTEM SET UP, etc.

⑤ **SET Button:**
Press to set each parameter you store or go to next step.

⑥ **CLEAR Button:**
Used to clear the previously entered function or go to previous step.

⑦ **XMT RESERVATION Indicator:**
The indicator lights during XMT RESERVATION setting.

⑧ **DELAYED XMT Indicator:**
The indicator lights during DELAYED XMT setting.

⑨ **POLLING Indicator:**
The indicator lights when POLLING setting.

⑩ **PROGRAM/REPORT Indicator:**
The indicator lights during system set up.

⑪ **RESOLUTION Button and Indicators:**
Used to set the scanning line density. The indicators light to show which setting you are using.

⑫ **CONTRAST Button and Indicators:**
Used to set the document contrast. The indicators light to show which setting you are using.

⑬ **HALF-TONE Button and Indicator:**
Press to send a document containing photographs, shaded drawings and the like. The indicator lights when the halftone feature is on.

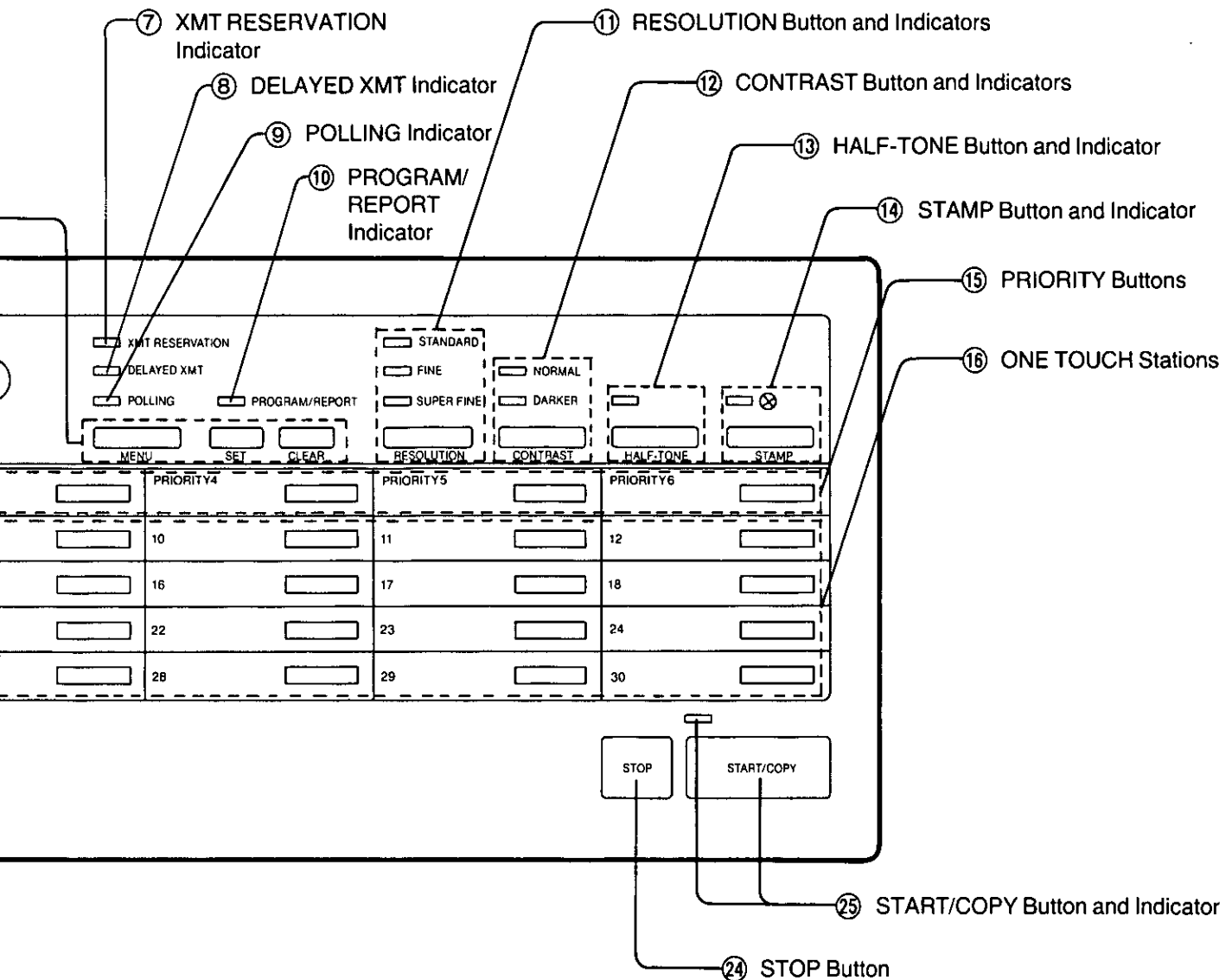

14 STAMP Button and Indicator:
Press to mark originals which have been sent. The indicator lights when this feature is on.

15 PRIORITY Buttons:
Used to program long dialing procedure (e.g. delayed communications) and extra ONE TOUCH station.

16 ONE TOUCH Stations:
Used for ONE TOUCH dialing.

17 DIAL KEYPAD:
Used to dial or program numbers.

18 TONE Button:
Used to change from pulse dialing mode to tone dialing mode while dialing.

19 MUTE Button and Indicator:
Use this feature when you do not want your voice to be heard by the other party. The indicator lights when this mode is on.

20 REDIAL Button:
Press to redial the last dialed number.

21 SP-PHONE Button and Indicator:
Used for on-hook dialing and voice contact feature. The indicator lights when this mode is on.

22 FUNCTION Selector:
Used to switch the unit between the telephone answering machine/facsimile function and the facsimile function only.

23 AUTO RECEIVE Button and Indicator:
Used to set to the Auto Receiving mode. The indicator lights when this mode is on.

24 STOP Button:
Used to cancel transmission or copy.

25 START/COPY Button and Indicator:
Used to start transmission or copy. The indicator lights during transmission or copy.

HOW TO READ THESE OPERATING INSTRUCTIONS

To use your unit easily and effectively, please understand these operating instructions completely. They are constructed as follows.

Caption: Explains the operation of the title in detail.

Title: The operation that you are going to do.

Recording an Outgoing Message (OGM)

To use the unit as both an answering machine and a facsimile, you should first record your Outgoing Message.

1



Press **OGM REC** until a long beep is heard, then release it.

- The IN USE indicator will light.

```
THU JUN29  3:00PM 00
OGM REC      >>>>>>>>
```

2

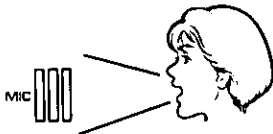

After the beep, speak immediately, clearly and loudly into the microphone, approximately 8 inches away.

- Recording time is 16 seconds.
- For optimum performance, record the OGM within 12 seconds.
- Do not pause for over 2 seconds while recording.

```
THU JUN29  3:00PM 00
OGM REC      ■■■■ >>>>
```

3



When recording is finished, press **OGM REC** again.

- The unit will play back the OGM to confirm your message. Adjust the VOLUME control to an audible level.
- Verifying your OGM, press OGM PLAY. The OGM will be played from the microchip.

```
THU JUN29  3:00PM 00
OGM PLAY    >>>>>>>>
```

```
THU JUN29  3:00PM 00
TAPE BACK UP
```

Display: appears following your operation.

Operation: gives you the detailed instructions including indicator's action.

Illustration: The controls on your unit are illustrated, and they give you the visual instructions.

Order: proceed in this order.

SYSTEM SET UP

Before using the unit:

■ Record an Outgoing Message.

When "RECORD OGM" appears on the LC Display, see page 2-1 in this manual.

■ Programming Date and Time.

If you want to change "Date and Time" on the LC Display, see page 15 in this manual.

Printing "SYSTEM SET UP LIST"

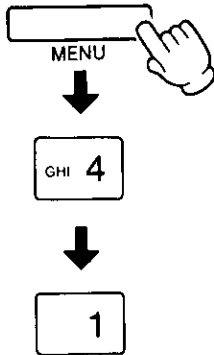

Press **MENU** 4 times.

- The PROGRAM/REPORT indicator will light.
- This display will appear.

PROGRAM [1. DATE 2. TEL
3. SYSTEM 4. REPORT]

Press "**4**", then press "**1**".

- The "SYSTEM SET UP LIST" will be printed.

SELECT NO. [1. SYSTEM
2. TEL NO. 3. JOURNAL]

PRINTING SYSTEM LIST

■ The following functions are user selectable, and may be changed as needed. Refer to next page.

***** SYSTEM SETUP LIST *****

```

#00 9/ 7/89 03:42PM
#01 YOUR LOGO =
#02 YOUR TELEPHONE NUMBER =
#03 LOGO POSITION = OUT
#04 PRINT JOURNAL = AUTO
#05 PRINT XMT REPORT = OFF
#06 MESSAGE OUT = OFF
  A = *** CONFIDENTIAL ***
  B = *** IMMEDIATE REPLY REQUESTED ***
  C =
#07 PAGE COUNTER = OFF
#08 REMOTE FAX ID = OFF
#09 REMOTE FAX ID NUMBER = 2222
#10 REMOTE ATAS ID = 111
#11 RECORDING TIME = VOX
#12 CPC MODE = A
#13 AUX LEADS = OUT
#14 DIAL PULSE = 10PPS
#15 TONE DETECT = OFF
#16 AUTO RECEIVE TIMER = OFF
    AUTO RECEIVE ON TIME = 12:00AM    AUTO RECEIVE OFF TIME = 12:00AM
#17 TX SPEED = 9600BPS
#18 RX SPEED = 9600BPS
#19 STAMP DEFAULT = OFF
#20 AUTO STANDBY = ON
#21 MAIN PASSWORD = 0000
#22 SEND PASSWORD = OFF
#23 TX PASSWORD CHECK = OFF
#24 RX PASSWORD CHECK = OFF
#25 POLLING PASSWORD = 0000
#26 SET DEFAULT = NO
#27 TEST (PRINT OR MOTOR)
< DELAYED MODE >
  DELAYED MODE = OFF
  PHONE NUMBER =
  PASSWORD = 0000
  START TIME = 12:00AM
  
```

■ System Programming Functions:

CODE	FUNCTION	PAGE
#00	DATE AND TIME	See page 15.
#01	YOUR LOGO	See page 18 in the INSTALLATION MANUAL.
#02	YOUR TELEPHONE NUMBER	See page 18 in the INSTALLATION MANUAL.
#03	LOGO POSITION	See page 22 in the INSTALLATION MANUAL.
#04	PRINT JOURNAL	See page 1-57.
#05	PRINT XMT REPORT	See page 1-63.
#06	MESSAGE OUT	See page 1-19.
#07	PAGE COUNTER	See page 1-16.
#08	REMOTE FAX ID	See page 1-17.
#09	REMOTE FAX ID NUMBER	See page 1-17.
#10	REMOTE ATAS ID	See page 2-3.
#11	RECORDING TIME	See page 2-4.
#12	CPC MODE	See page 4-9.
#13	AUX. LEADS	See page 4-10.
#14	DIAL PULSE	See page 4-11.
#15	TONE DETECT	See page 4-12.
#16	AUTO RECEIVE TIMER	See page 1-21.
#17	TX SPEED	See page 4-13.
#18	RX SPEED	See page 4-14.
#19	STAMP DEFAULT	See page 4-15.
#20	AUTO STANDBY	See page 4-16.
#21	MAIN PASSWORD	See page 1-50.
#22	SEND PASSWORD	See page 1-50.
#23	TX PASSWORD CHECK	See page 1-50.
#24	RX PASSWORD CHECK	See page 1-50.
#25	POLLING PASSWORD	See page 1-23.
#26	SET DEFAULT	See page 4-17.
#27	TEST [PRINT OR MOTOR]	See page 4-17.

In the SYSTEM PROGRAMMING mode, the message will be changed as follows each time you press the SET button. The CLEAR button allows to go to the previous display.

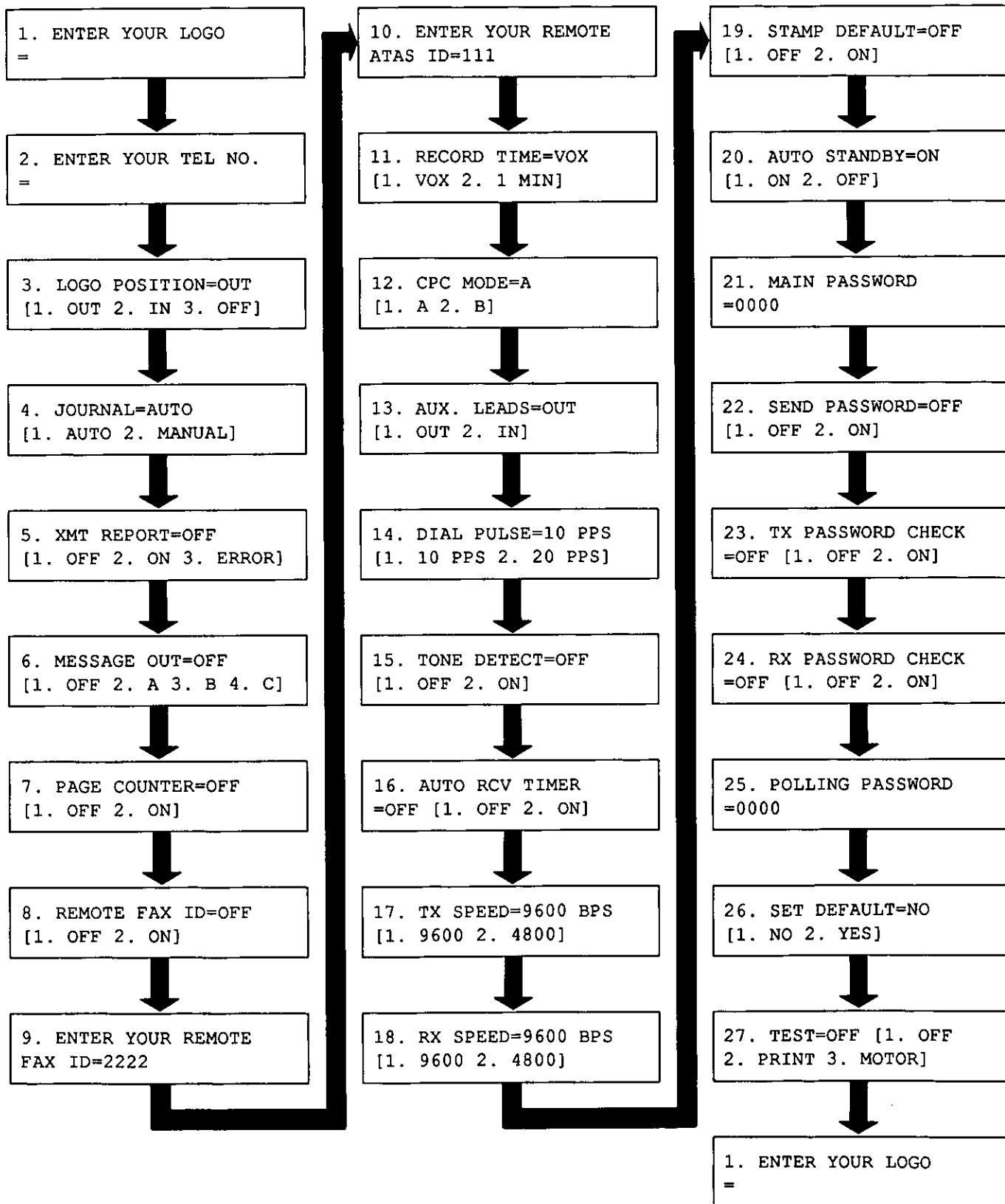

SYSTEM SET UP (CONT.)

Programming Date and Time

Example: JUN. 15, 1989 3:00 P.M.

1

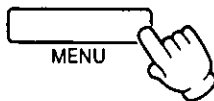

Press **MENU** 4 times.
 •The PROGRAM indicator will light.
 •This display will appear.

PROGRAM [1. DATE 2. TEL
 3. SYSTEM 4. REPORT]

2

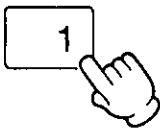

Press "1".

SET DATE [*=AM #=PM]
 01 01 89 12:00AM SUN]

3

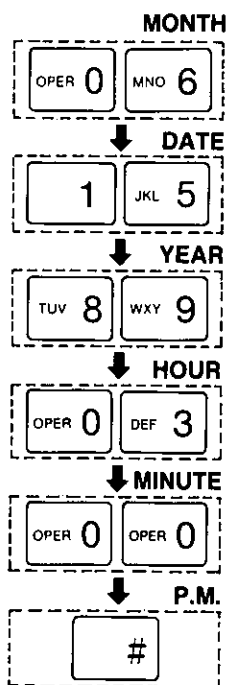

Enter the new clock setting in the format **MONTH/DATE/YEAR/HOUR/MINUTE** (2 digits)/**AM** or **PM**.
 •Press "*" and "#" to select AM/PM mode.
 •Day of the week will be set automatically.

SET DATE [*=AM #=PM]
 06 15 89 03:00PM THU]

4

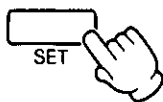

When you have set the clock, press **SET**.
 •The clock will start.

PROGRAM [1. DATE 2. TEL
 3. SYSTEM 4. REPORT]

5



Press **MENU** to end the operation.

THU JUN 15 3:00PM 00

MANUAL DIALING

Making a Call

■ Using the Handset

1. Lift the handset and dial the phone number.
2. Speak with the other party.
3. Hang up the handset when finished.

■ On-hook Dialing (Hands-Free Operation)

1



Press **SP-PHONE**.

- The SP-PHONE indicator will light.

THU JUN 15 3:00PM 00
ENTER PHONE NUMBER

2



Dial the phone number, then speak.

- The display will show the dialed phone number.

THU JUN 15 3:00PM 00
XXXXXXXX

— dialed number

3

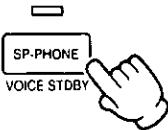

When finished, press **SP-PHONE** again.

- The SP-PHONE indicator will go out.

HELPFUL HINTS FOR HANDS-FREE OPERATION:

- If it is difficult to hear the other party's voice; raise the sound level using the **SPEAKER VOLUME** control.
- If the other party has difficulty hearing you; lower the sound level.
- Absorbing echoes; use this unit in a room which has curtains or carpeting.
- To avoid lost or broken conversations; If you and the other party speak at the same time, parts of your conversation will be lost. To avoid this, speak alternately.

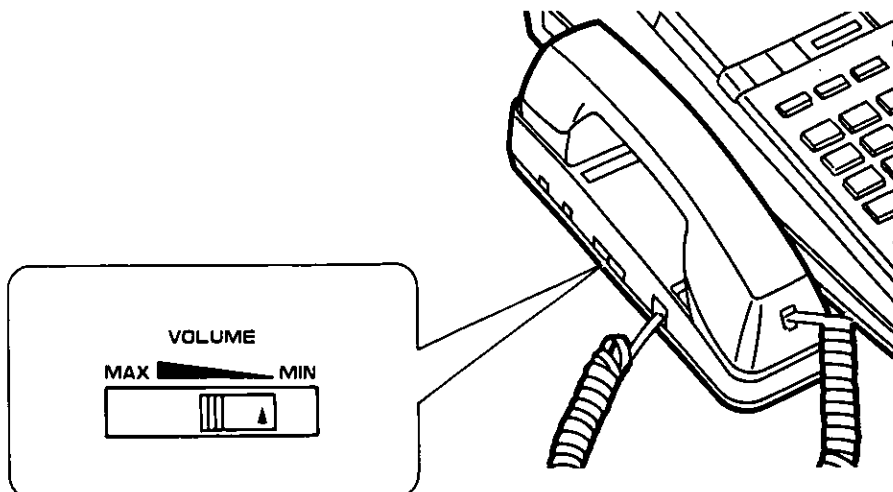

MANUAL DIALING (CONT.)

Receiving a Call

When the phone rings, lift the handset or press the SP-PHONE button to answer a call.

Redialing for Manual Dialing

You can redial the last dialed number by simply pressing the REDIAL button.

Press **REDIAL** if busy tone is heard.

<REDIALING>
XXXXXXXX
last dialed number

■ When using the handset:

Depressing the REDIAL button redials the last number once.

■ When using the Hands-Free Operation:

The unit will automatically redial up to 15 times within a 10-minute period.
(Automatic Redialing)

During the pause between each redialing, the display will show the following messages, and the SP-PHONE indicator will flash slowly.

THU JUN 15 3:00PM 00
WAITING TO REDIAL

To cancel the automatic redialing, press the FLASH button.

MANUAL TRANSMISSION AND RECEPTION

Manual Transmission

1

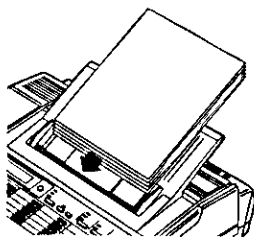

Insert a document **FACE DOWN**.

- The unit will accept up to 15 sheets of paper at a time.

2



Lift the handset or press **SP-PHONE**, then dial the fax number.



THU JUN15 3:00PM 00
ENTER PHONE NUMBER

THU JUN15 3:00PM 00
XXXXXXXX

dialed number

3

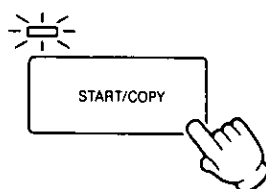

When the beep (**answering carrier tone**) is heard, press **START/COPY**.

SENDING P 1
TO: XXXXXXXX

4

After pressing **START/COPY**, replace the handset if using the handset.

- During a fax transmission, the number of each page (99 max.) is displayed.

SENDING P 1
TO: XXXXXXXX

THU JUN15 3:03PM 00
1 PAGE SENT OK

- Begin by transmitting the FAX CORRESPONDENCE leaflet (included) to several of your business associates to confirm that your unit is functioning correctly, and to inform them of the procedure for transmitting documents and/or recording voice-messages on your unit.

MANUAL TRANSMISSION AND RECEPTION (CONT.)

Manual Reception

1



When the phone rings, lift the handset or press **SP-PHONE** to answer the call.

2

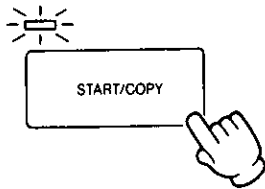

Press **START/COPY** to receive a document.

RECEIVING P 1
FROM: XXXXXXXX

Station name,
telephone number
or <G3>

3

After pressing **START/COPY**, replace the handset if using the handset.

- During a fax reception, the number of each page (99 max.) is displayed.

■ START/COPY indicator:

It will change from a flashing to a steady light, and the unit will begin transmitting or receiving documents.

NOTE:

• If you are using the speakerphone;

The line will be automatically disconnected after transaction is completed.

• If you do not hang up the handset after pressing the START/COPY button;

The unit will automatically call the other party. For further details, see "VOICE CONTACT" on page 1-15.

How to Operate as a Facsimile Machine

BEFORE TRANSMITTING A DOCUMENT

Transmissible Document

The unit can transmit a document of the following sizes, weight and textures.

- Original width is 128 mm (5") to 216 mm (8½").
- Effective width is up to 208 mm (8¾").
- Weight of transmissible document is 12 to 24 pounds.

Maximum document size

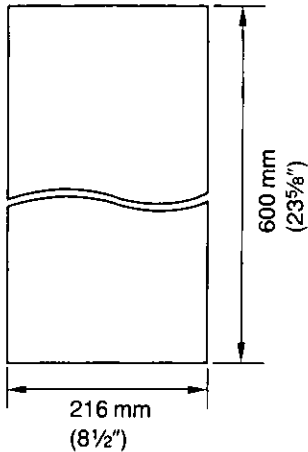

Minimum document size

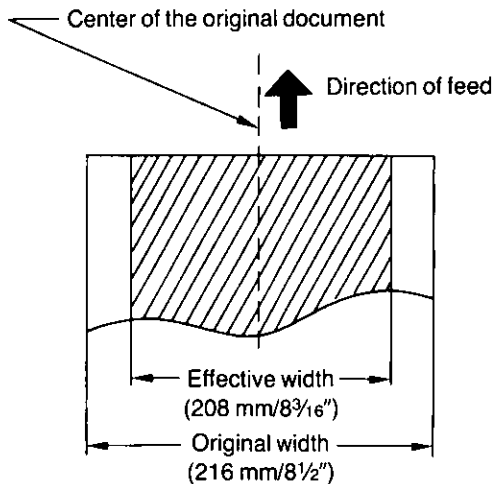
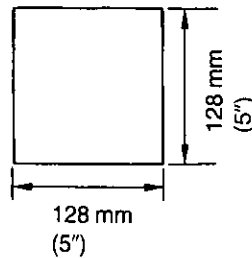

■ Automatic Document Feeder:

- Up to 15 sheets of paper at the same time
- Bond paper (16 to 20 pounds)
- Paper with uncoated surface

NOTE:

- A document which is over 600 mm (23 5/8") cannot be transmitted. The unit will stop transmitting a document and the display will show "REMOVE DOCUMENT". If this happens, press the STOP button to remove the document.
- If the originals are electrostatically charged, the automatic document feeder may not function properly.

Do not feed the following types of document into the unit or it may jam. Make copies of the document, and feed the copies into the unit. Or use the exclusive carrier sheet included with your unit.

We recommend you to use the carrier sheet or make the copies and feed the copies for the following originals:

- Paper with chemically treated surfaces such as carbon-blackened paper or carbonless duplicating paper
- Heavily curled, creased or torn paper
- Paper with a coated surface
- Small size paper such as a slip or a voucher
- Thin paper (less than 12 pounds)

We recommend you to make copies and feed the copies for the following originals:

- Thick paper (over 24 pounds), since a carrier sheet cannot be used
- When the contrast between the printed letter and background is small
- When the letters printed on the back side can be seen from the front of the paper (e.g. newspaper)

Remove clips, staple or other similar objects from a document before feeding it into the unit.

Let ink or paste on a document dry completely before feeding them into the unit.

Using the Carrier Sheet

1. Place an original into the carrier sheet with the print facing a transparent cover.
2. Place the transparent cover over the original.
3. Insert the carrier sheet.

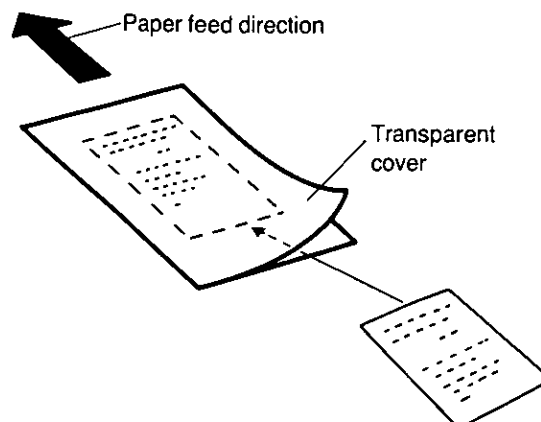

BEFORE TRANSMITTING A DOCUMENT (CONT.)

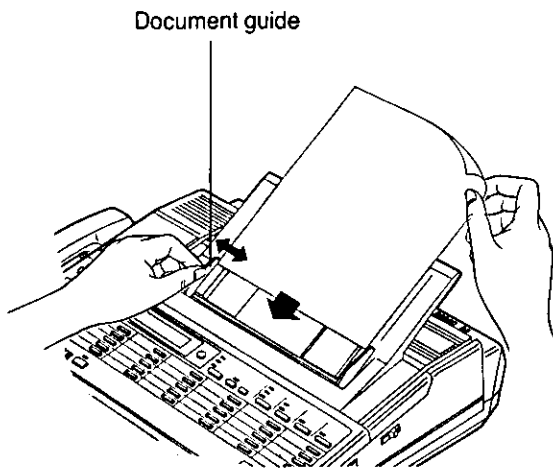

This unit will accept up to 15 sheets of paper at a time.

Place the document on the tray **FACE DOWN**, and align them.

After aligning the document, adjust the document guide according to the document width.

Make sure to insert the document properly and to feed a bottom sheet first.

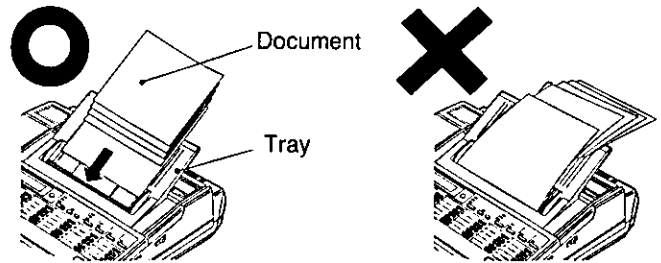

- The following functions must be set before starting a transmission.
If you set these functions while a document is being fed, the functions are effective from the next sheet of paper.

Resolution (Scanning Line Density):

STANDARD is suitable for printed or typewritten originals with normal size characters.

FINE is suitable for originals written with small characters.

SUPER FINE doubles the resolution of FINE. (**SUPER FINE** works between KX-F220's alone)

Document Contrast:

NORMAL is suitable for transmitting or copying printed or typewritten document.

DARKER is suitable for transmitting or copying originals written in light documents.

Verification Stamp:

The verification stamp helps you to confirm successful transmissions by stamping the bottom of each document with a small ⊗ mark.

Half-Tone:

This function is useful when sending originals containing photographs, shaded drawings and the like.

● When you press this button, **RESOLUTION (FINE)** will be selected automatically.

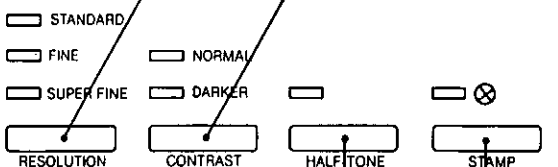

TRANSMITTING A DOCUMENT

Manual Transmission

1

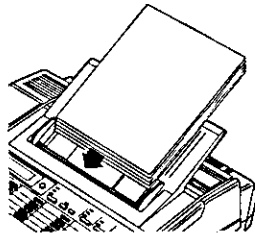

Insert a document **FACE DOWN**.

2



Lift the handset or press **SP-PHONE**, then **dial the fax number**.

THU JUN 15 3:00PM 00
ENTER PHONE NUMBER

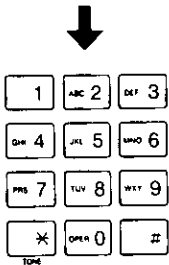

THU JUN 15 3:00PM 00
XXXXXXXX

dialed number

3

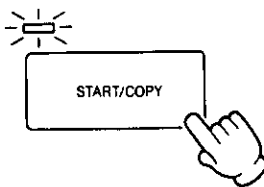

When the beep (**answering carrier tone**) is heard, press **START/COPY**.

SENDING P 1
TO: XXXXXXXX

4

After pressing **START/COPY**, replace the handset if using the handset.
•During a fax transmission, the number of each page (99 max.) is displayed.

SENDING P 1
TO: XXXXXXXX



THU JUN 15 3:03PM 00
1 PAGE SENT OK

TRANSMITTING A DOCUMENT (CONT.)

Inserting a document.



Pressing a One-Touch button.



When Using One-Touch Dialing

For convenience, you can program up to 24 facsimile or voice telephone numbers into 24 ONE-TOUCH stations. 6 PRIORITY buttons also can be used as One-Touch station. (Refer to page 1-41.)

The following method will let the unit dial and transmit documents automatically. As to programming for One-Touch Dialing, refer to "PROGRAMMING AUTOMATIC DIALING NUMBERS" on page 1-35.

1

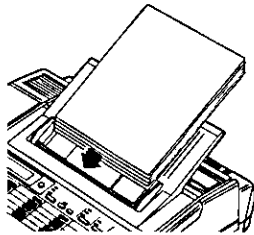

Insert a document FACE DOWN.

- A beep will sound.

THU JUN 15 5:00PM 00

2

Example: One-Touch station 7

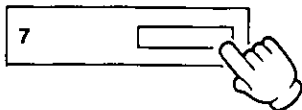

Press the One-Touch station which contains the facsimile number you wish to transmit to.

- The START/COPY indicator will change from a flashing to a steady light, and then a document will begin to transmit.

DIALING <XMT>
TO:XXXX



SENDING P1
TO:XXXX

Station name
or dialed number



THU JUN 15 5:01PM 00
1 PAGE SENT OK

Inserting a document.



Pressing three buttons.

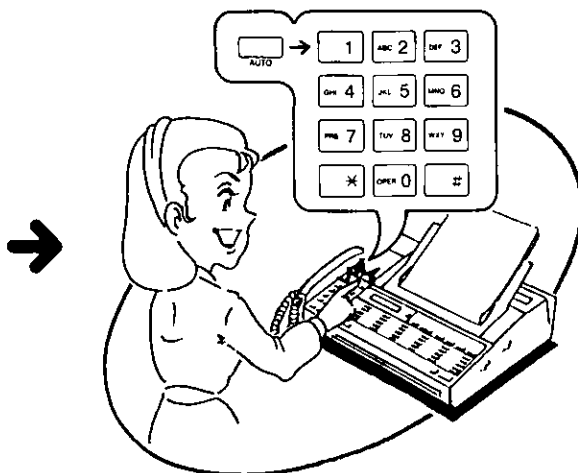

When Using Speed Dialing

For convenient transmission, you can program facsimile numbers into 100 memory stations. As to programming for Speed Dialing, refer to "PROGRAMMING AUTOMATIC DIALING NUMBERS" on page 1-37.

1

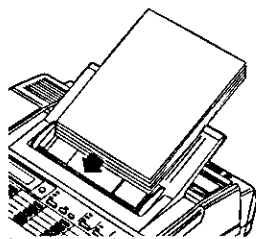

Insert a document FACE DOWN.
•A beep will sound.

THU JUN 15 5:30PM 00

2

Example: The station number 00

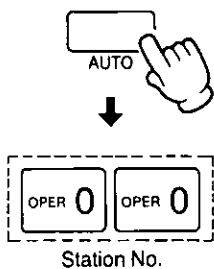

Press AUTO, then enter the speed dial number (00 to 99, 2-digit).

THU JUN 15 5:30PM 00
<A00>

DIALING <XMT>
TO:XXXXX

SENDING P.1
TO:XXXXX

Station name
or dialed number

THU JUN 15 5:31PM 00
1 PAGE SENT OK

TRANSMITTING A DOCUMENT (CONT.)

Starting reservation



Completed reservation

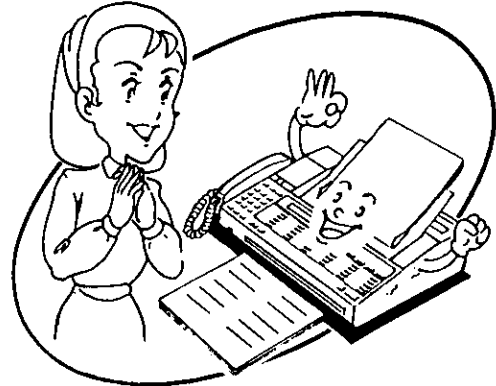

Transmitting Reservation

While the unit is receiving a document from one station, you can reserve transmission to another. The unit will transmit a document automatically after the receiving process is completed.

Receiving mode display.

RECEIVING
FROM: XXXXXXXX

Telephone number,
station name or <G3>

XMT RESERVATION
ENTER PHONE NUMBER

1



Press **MENU**.

- The XMT RESERVATION indicator will light.
- This display will appear.

2

Example: One-Touch station 7

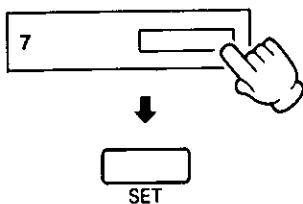

Press the **ONE TOUCH** station, or press **AUTO** and station number (2-digit), or enter phone number with dial keypad.

ENTER PHONE NO.
=<S07>

Press **SET**.

INSERT DOCUMENT
FACE DOWN

3

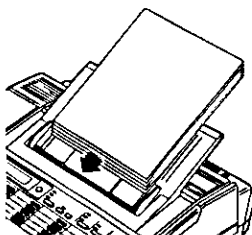

Insert a document **FACE DOWN**.

- The unit will transmit a document automatically after receiving is finished.

NOTE:

This function cannot be used when this unit is transmitting, polling or being programmed for delayed transmission and polling.

Being busy on line

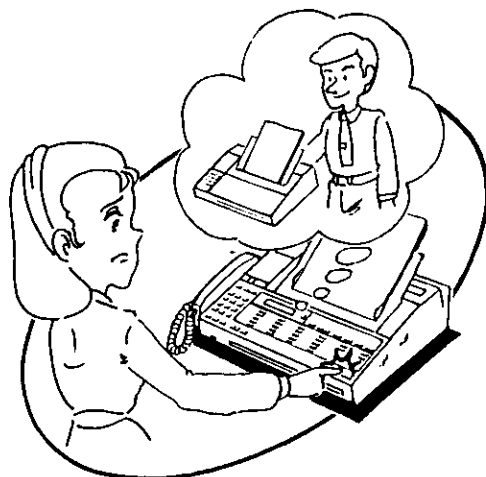

Redialing automatically

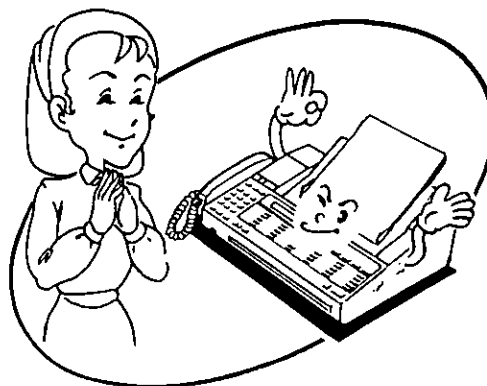

Redialing for One-Touch and Speed Dialing

If there is no answer or the line is busy, the unit will automatically redial the number up to 6 times within a 10-minute period and the display will show;

```
THU JUN 15  5:30PM 00  
WAITING TO REDIAL
```

■ If there is still no answer after six (6) tries, the display shown below will appear.

```
THU JUN 15  5:30PM 00  
REDIAL TIME OUT
```

■ To stop the redialing, press the STOP button, original display will appear and the beep will be heard.

```
THU JUN15 5:30PM 00
```

TRANSMITTING A DOCUMENT (CONT.)

Programming a transmission time



Transmission at programmed time

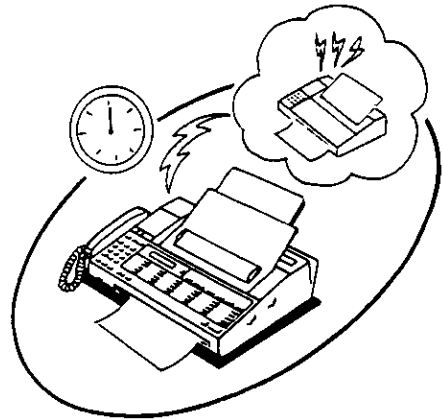

Setting Delayed Transmission

The unit is equipped with a built-in timer. By programming the unit with a starting time and a facsimile telephone number, you can automatically transmit a document anywhere in the world, and at any time of the day. This operation can be reserved to take place up to 24 hours after setting the timer.

1



Press **MENU** twice.

- The DELAYED XMT indicator will light.
- This display will appear.

DELAYED XMT=OFF
[1. OFF 2. ON]

Press "2".

DELAYED XMT=ON
[1. OFF 2. ON]

Press **SET**.

ENTER PHONE NUMBER
=

2

Example: One-Touch station 8

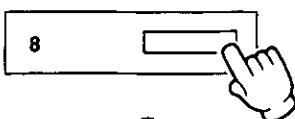

Enter the facsimile telephone number using the one-touch dialing, speed dialing or a full number.

Press **SET**.

ENTER PHONE NUMBER
=<S08>

SET START TIME
12:00 AM [*=AM #=PM]

3

Example: Starting time is 8:30 P.M.

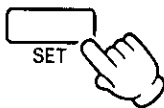
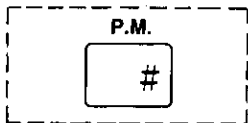
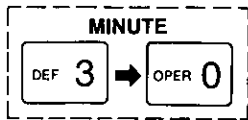
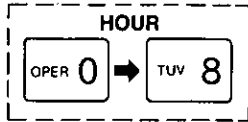

Enter the time at which the fax is to be Transmitted.

- Press "*" or "#" to select AM/PM mode.
- To correct an error while programming, press the CLEAR button, then enter the correct input.

```

SET START TIME
08:30 PM [*=AM #=PM]
  
```

Press **SET**.

```

INSERT DOCUMENT
FACE DOWN
  
```

4

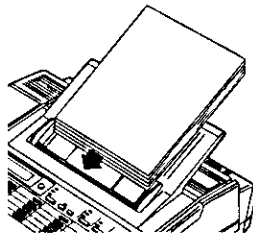

Insert a document FACE DOWN.

- The document will be transmitted at the time selected.

```

THU JUN 29 05:00 PM 00
XMT AT 8:30PM
  
```

NOTE:

- Automatic and manual reception, transmission and copying function can be performed even when delayed transmission is set. To copy another document, remove the document on the tray and replace it when you finish.
- If there is no answer or the line is busy when performing the delayed transmission, the unit will automatically redial the number, up to 6 times within a 10-minute period.
- You cannot set a new Delayed Transmission before transmitting document reserved by the previous Delayed Transmission setting or the previously entered setting will be overridden.

RECEIVING A DOCUMENT AND/OR VOICE-MESSAGE

Manual Reception

1



When the phone rings, lift the handset or press **SP-PHONE** to answer the call.

2

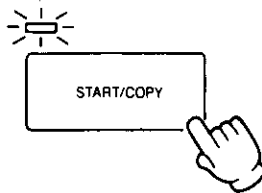

Press **START/COPY** to receive a document.

RECEIVING P 1
FROM: XXXXXX

3

After pressing **START/COPY**, replace the handset if using the handset.

- During a fax reception, the number of each page (99 max.) is displayed.

RECEIVING P 1
FROM: XXXXXX

Telephone number,
station name
or <G3>

■ **START/COPY indicator:**

It will change from a flashing to a steady light, and the unit will begin transmitting or receiving a document.

- Begin by transmitting the FAX CORRESPONDENCE leaflet (included) to several of your business associates to confirm that your unit is functioning correctly, and to inform them of the procedure for transmitting documents and/or recording voice-messages on your unit.

NOTE:

• If you are using the speakerphone;

The line will be automatically disconnected after transaction is completed.

• If you do not hang up the handset after pressing the **START/COPY** button;

The unit will automatically call the other party. For further details, see "VOICE CONTACT" on page 1-15.

Explanation of Auto Receiving Mode

The KX-F220 can receive a document either automatically or manually. When set to automatic, you can receive a document and/or voice-messages without the need for manual operations.

The unit has two Auto Receiving modes;

- A) You can use the unit as both an answering and a facsimile machine.
- B) You can use the unit as a facsimile machine only.

Receiving Voice-Messages and a Document Automatically (Using as an Answering and a Facsimile Machine)

You should first record an **Outgoing Message (OGM)**.

Refer to "Recording an Outgoing Message" on page 2-1.

1

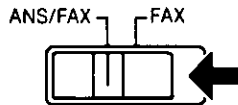

Set **FUNCTION** selector to the **ANS/FAX** position.

- **ANS/FAX position:**
The unit switches between an answering and a facsimile functions automatically.

2

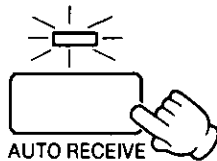

Press **AUTO RECEIVE**.

- The **AUTO RECEIVE** indicator will light.

- When a call is received, the unit will begin playing back your OGM. Then the unit will automatically function as an answering machine or a facsimile depending on the caller's choice.
- If the caller's voice is not detected, the unit will automatically enter facsimile mode.

RECEIVING A DOCUMENT AND/OR VOICE-MESSAGE (CONT.)

Receiving a Document Automatically (Using as a Facsimile Machine)

When a call is received, the unit will produce the answering carrier tone to receive a document. Then the unit will receive a document automatically. At this time, your OGM will not be played.

1

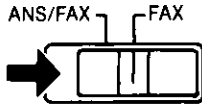

Set **FUNCTION** selector to the **FAX** position.

• **FAX position:**

The unit will function as a facsimile machine only.

2

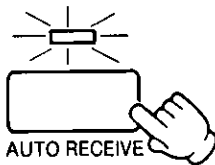

Press **AUTO RECEIVE**.

- The **AUTO RECEIVE** indicator will light.

Cancelling Auto Receiving Mode

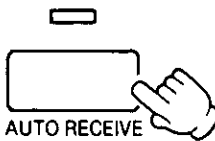

Press **AUTO RECEIVE** again.

- The **AUTO RECEIVE** indicator will go out.

Setting Auto Receiving Mode Remotely

Call your unit, and let the telephone ring 15 times. The unit will go into the Auto Receiving Mode. You can then hang up.

NOTE:

- This unit will answer on the first ring by default. You can change the ring count according to the instructions found on pages 26 and 27 in the **INSTALLATION MANUAL**.
- If you encounter difficulty in receiving a document from facsimile machines which have an automatic transmission feature, you will need to keep "RING COUNT" number at one (see pages 26 and 27 in the **INSTALLATION MANUAL**)

TRANSMITTING TO YOUR KX-F220 FROM A REMOTE LOCATION

Recording Your Message and Transmitting a Document

■ From tone phone:

1



Call your unit, then leave your message after the long beep following your OGM.

2

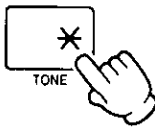

When recording is finished, press "*" to change your unit to the facsimile mode.

- Start transmission after hearing the answering carrier tone.
- If you have selected the REMOTE FAX ID to ON, enter your REMOTE FAX ID after "*".

■ From rotary (pulse) phone:

When the calling facsimile machine has a voice-contact function, you can leave a message with your facsimile.

- If Remote Fax ID (page 1-17) is set to on your KX-F220, rotary phone cannot access your KX-F220.

1. Call your unit.
2. While the OGM is playing, press your mute button or cover the mouthpiece of your handset.
3. Start transmission after hearing the answering carrier tone.
4. Make a call reservation (e.g. ...lift the handset) during transmission.
5. Record your message after the long beep following your OGM.

Transmitting a Document Only

■ From tone phone:

1



Call your unit.

2

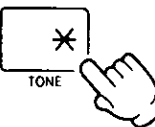

When your OGM starts, press "*" to change your unit to the facsimile mode.

- Start transmission after hearing the answering carrier tone.

■ From rotary (pulse) phone:

- If Remote Fax ID (page 1-17) is set to on your KX-F220, rotary phone cannot access your KX-F220.

1. Call your unit.
2. While the OGM is playing, press your mute button or cover the mouthpiece of your handset.
3. Start transmission after hearing the answering carrier tone.

VOICE CONTACT

Initiating Voice Contact During Transmission/Reception

While you are transmitting or receiving a document, you may wish to speak with the other party. If the other party's unit is equipped with a voice contact feature, you can initiate voice contact as follows.

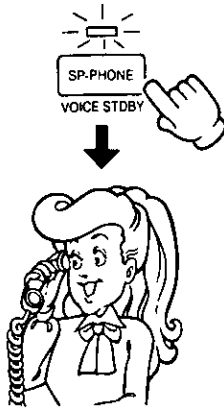

Lift the handset or push SP-PHONE while transmitting or receiving documents.

RECEIVING P 1
VOICE STANDBY

SENDING P 1
VOICE STANDBY

When the other party answers, start speaking.

- **If you initiate voice contact during transmission;** you will be able to speak after all of the document have been transmitted. The other party's unit will ring or beep depending on the type of unit they have.
- **If you initiate voice contact during receipt of a document;** you will be able to speak after receiving the current page of the document. The other party's unit will ring or beep depending on the type of unit they have, after the current page has been transmitted.
- It may happen that the voice contact cannot be done according to some certain type of the voice contact provided with the other party's unit.

Receiving a Request for Voice Contact

If the other party tries to contact you during transmission or reception, the unit will beep.

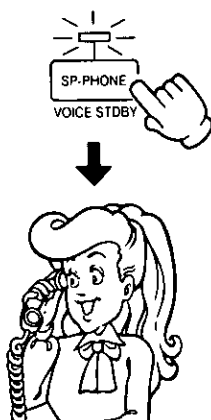

Lift the handset or press SP-PHONE after hearing several beeps.

RECEIVING P 1
PLEASE PICK UP

SENDING P 1
PLEASE PICK UP

Start speaking.

NOTE:

If you do not answer within 10 seconds after hearing several beeps indicating the request for voice contact, one of two conditions will occur;

- When the FUNCTION selector is set to the FAX position, the unit will be disconnected.
- When the FUNCTION selector is set to the ANS/FAX position and the unit is in the Auto Receiving mode, the unit will play back your OGM and record the voice-message. If the unit is in the manual receiving mode, the unit will be disconnected.

SETTING "PAGE COUNTER"

When the PAGE COUNTER function is set to ON, the page number will be printed at the top of each page you transmitted.

The unit requests you to enter the total number of pages you transmit.

At this time, enter the number then press the SET button.

- Correcting an error while entering; press the CLEAR button and enter correct input.

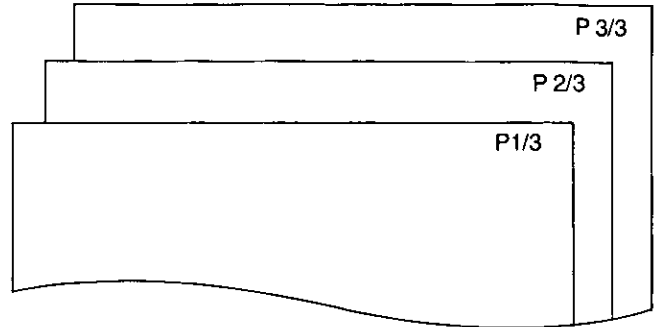

SET NUMBER OF PAGES
TOTAL=0

1

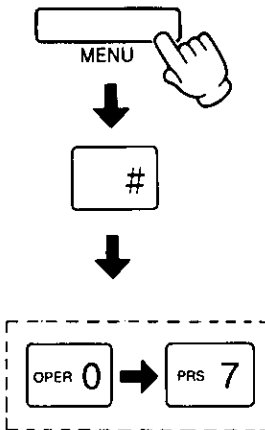

Press **MENU** 4 times.

- The PROGRAM indicator will light.
- This display will appear.

PROGRAM [1. DATE 2. TEL
3. SYSTEM 4. REPORT]

Press "#", then press "07".

7. PAGE COUNTER=OFF
[1. OFF 2. ON]

2

Example: Page Counter is "ON".

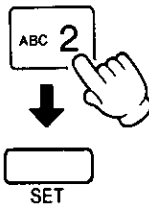

Press "2", then press **SET**.

7. PAGE COUNTER=ON
[1. OFF 2. ON]

PROGRAM [1. DATE 2. TEL
3. SYSTEM 4. REPORT]

3



Press **MENU** to end the operation.

THU JUN 15 5:00PM 00

REMOTE FAX ID

A remote Fax ID is to prevent unauthorized persons accessing your unit from a remote location. A remote Fax ID can be any of following ranges:

We recommend you to set different number from ATAS ID (page 2-3), to prevent accessing the answering machine.

1 digit: 1 to 9

2 digits: 10 to 99

3 digits: 100 to 999

4 digits: 1000 to 9999

Setting Remote Fax ID

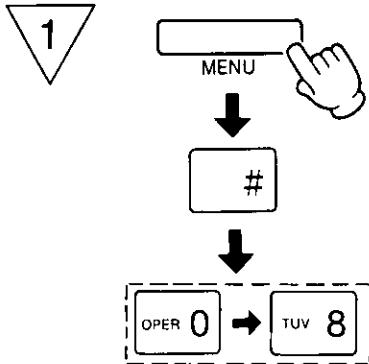

Press **MENU** 4 times.

- The PROGRAM indicator will light.
- This display will appear.

PROGRAM [1. DATE 2. TEL
3. SYSTEM 4. REPORT]

Press “#”, then press “08”.

8. REMOTE FAX ID=OFF
[1. OFF 2. ON]

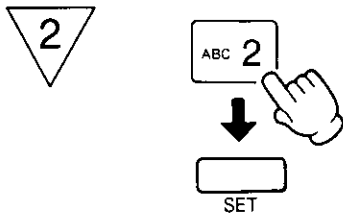

Press “2”, then press **SET** to set to ON.

8. REMOTE FAX ID=ON
[1. OFF 2. ON]

PROGRAM [1. DATE 2. TEL
3. SYSTEM 4. REPORT]

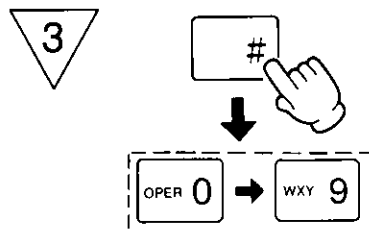

Press “#”, then press “09”.

9. ENTER YOUR REMOTE
FAX ID=2222

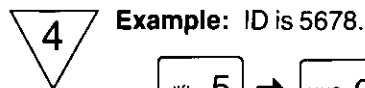

Enter the desired remote Fax ID, then press **SET**.

9. ENTER YOUR REMOTE
FAX ID=5678

PROGRAM [1. DATE 2. TEL
3. SYSTEM 4. REPORT]

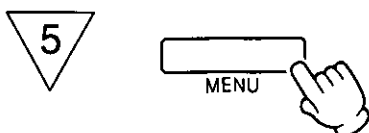

Press **MENU** to end the operation.

Transmitting a Document with Remote Fax ID to Your KX-F220 from a Remote Location

1



Call your unit.

2

Example: ID is 5678.

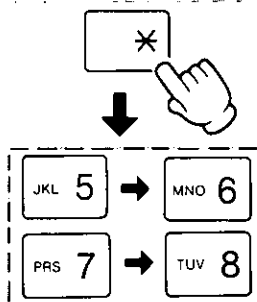

When the **OGM** is heard, press “*” then enter the **remote FAX ID**.

- OGM is stopped, then the answering carrier tone is heard.

3

Start transmission after hearing the answering carrier tone.

SETTING THE "MESSAGE OUT"

This function offers you to put your message on top of transmitted document. You may choose the message from the following selections. The message has been preset to "OFF" at the factory.

- A: *** CONFIDENTIAL *****
- B: *** IMMEDIATE REPLY REQUESTED *****
- C: You can program a message of your own.**
- OFF: No message.**

Example: A

```
FROM : Panasonic                AUG. 29. 1989  1:17 PM  P 1
*** CONFIDENTIAL ***
```

Example: B

```
FROM : Panasonic                AUG. 29. 1989  1:23 PM  P 1
*** IMMEDIATE REPLY REQUESTED ***
```

Example: C

```
FROM : Panasonic                AUG. 29. 1989  1:28 PM  P 1
URGENT!
```

Programmed message

1

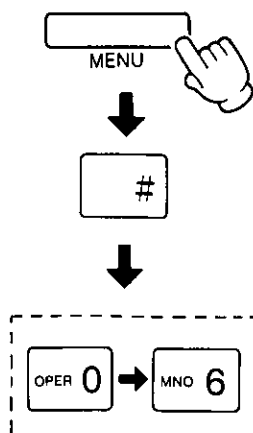

Press **MENU** 4 times.

- The PROGRAM indicator will light.
- This display will appear.

```
PROGRAM [1. DATE 2. TEL
3. SYSTEM 4. REPORT]
```

Press "#", then press "06".

```
6. MESSAGE OUT=OFF
[1. OFF 2. A 3. B 4. C]
```

2

Press the buttons as follows.

Selecting A mode (***) CONFIDENTIAL (***)

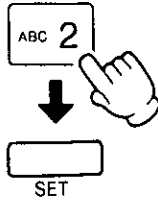

Press "2", then press **SET**.

6. MESSAGE OUT=A
 [1. OFF 2. A 3. B 4. C]

PROGRAM [1. DATE 2. TEL
 3. SYSTEM 4. REPORT]

Selecting B mode (***) IMMEDIATE REPLY REQUESTED (***)

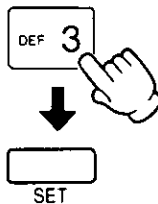

Press "3", then press **SET**.

6. MESSAGE OUT=B
 [1. OFF 2. A 3. B 4. C]

PROGRAM [1. DATE 2. TEL
 3. SYSTEM 4. REPORT]

Selecting C mode (your own message)

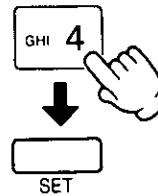

Press 4, then press **SET** then enter a sentence you wish to print using the ONE TOUCH station button up to 64 characters.

(e.g. If the message is "URGENT!")

- For the usage of the ONE TOUCH station button, see the page 19 in the INSTALLATION MANUAL.

6. MESSAGE OUT=C
 [1. OFF 2. A 3. B 4. C]

PLEASE SET MESSAGE
 =URGENT!

Example: U

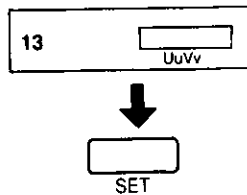

Press SET to store it into memory.

PROGRAM [1. DATE 2. TEL
 3. SYSTEM 4. REPORT]

Selecting OFF

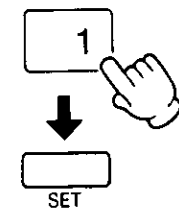

Press "1", then press **SET**.
 •No message will be printed.

6. MESSAGE OUT=OFF
 [1. OFF 2. A 3. B 4. C]

PROGRAM [1. DATE 2. TEL
 3. SYSTEM 4. REPORT]

TURNING ON/OFF THE AUTO RECEIVING MODE

This function allows you to make the Auto Receiving mode ON or OFF for the desired time. Use "AUTO RCV TIMER" for programming. The Auto Receiving mode automatically turn on or off at the programmed time.

Example: Company XYZ

Company XYZ wants the unit to set to the Auto Receiving mode automatically from 5:00 PM. to 9:00 AM.

1

Press **MENU** 4 times.

- The PROGRAM indicator will light.
- This display will appear.

PROGRAM [1. DATE 2. TEL
3. SYSTEM 4. REPORT]

Press "#", then press "16".

16. AUTO RCV TIMER
=OFF [1. OFF 2. ON]

2

Press "2", then press **SET**.

AUTO RCV ON TIME
12:00AM [*=AM #=PM]

3

Example: ON time is 5:00 PM.

Enter the ON time, then press **SET**.

AUTO RCV ON TIME
05:00PM [*=AM #=PM]

AUTO RCV OFF TIME
12:00AM [*=AM #=PM]

4

Example: OFF time is 9:00 AM.

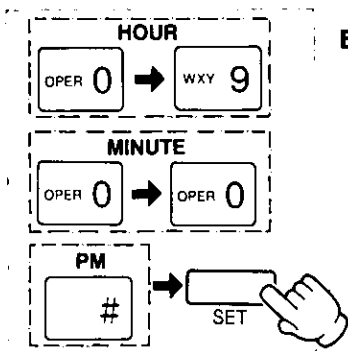

Enter the OFF time, then press SET.

AUTO RCV OFF TIME
09:00AM [*=AM #=PM]

PROGRAM [1. DATE 2. TEL
3. SYSTEM 4. REPORT]

5

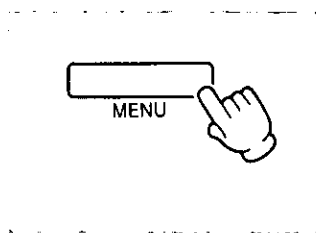

Press **MENU** to end the operation.

POLLING

Polling is that you call the other station(s) to retrieve the document.

The other party must know in advance that you will call, and must insert a document on the document tray.

You also need to program a polling password before transmission. This "POLLING" function may be performed between the FAX's which have the same protocol.

Programming the Polling Password

The first step in using the polling feature is to program your polling password. The password is a 4-digit number, which is checked during the polling operation. If the password of the polling unit and that of the unit being polled do not match, polling cannot take place.

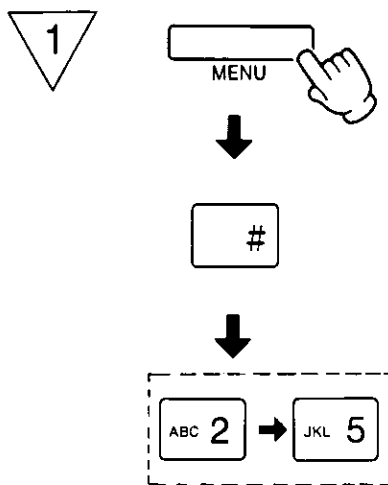

Press **MENU** 4 times.

- The PROGRAM indicator will light.
- This display will appear.

PROGRAM [1. DATE 2. TEL
3. SYSTEM 4. REPORT]

Press "#", then press "25".

25. POLLING PASSWORD
=0000

2 **Example:** Password is 1234.

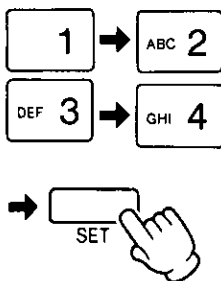

Enter your polling password, then press SET to store it into memory.

- To correct an error while programming; press CLEAR, and then enter correct input.

25. POLLING PASSWORD
=1234

PROGRAM [1. DATE 2. TEL
3. SYSTEM 4. REPORT]

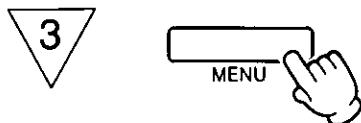

Press **MENU** to end the operation.

THU JUN 29 3:00 PM 00

NOTE:

If the polling password is set to "0000", the unit does not check password.

The polling is allowed only between KX-F220's which have same polling password programmed.

Preparation for Being Polled

In order to let other stations poll your unit, you must set a document on the tray of the unit. After being polled, the unit will automatically return to the Auto Receiving mode.

1



Press **MENU** 3 times.

- The POLLING indicator will light.
- This display will appear.

POLLING [1. OFF 2. ON
3. XMT & POLL 4. POLLED

2

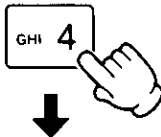

Press "4".

READY TO BE POLLED
PRESS SET KEY



Press **SET**.

INSERT DOCUMENT
FACE DOWN

3

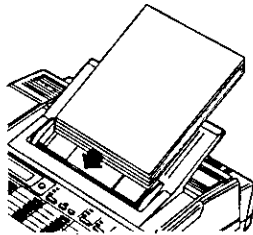

Insert a document **FACE DOWN**, then press **AUTO RECEIVE** to set to the Auto Receiving mode.

THU JUN 29 3:00PM 00
POLLED ON

When another station polls your unit, transmission is performed automatically.

NOTE:

Polled station should be set the REMOTE FAX ID to off. See page 1-17.

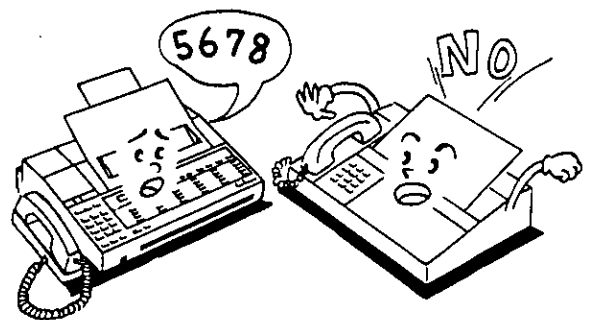
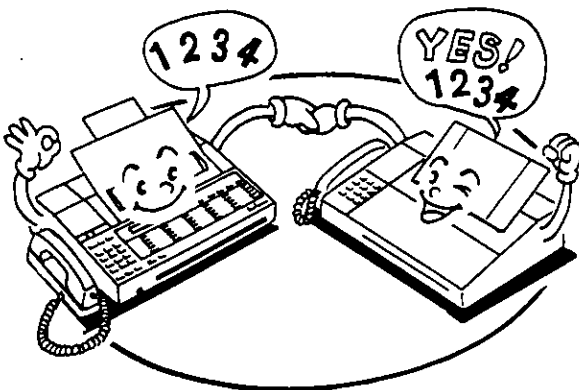

POLLING (CONT.)

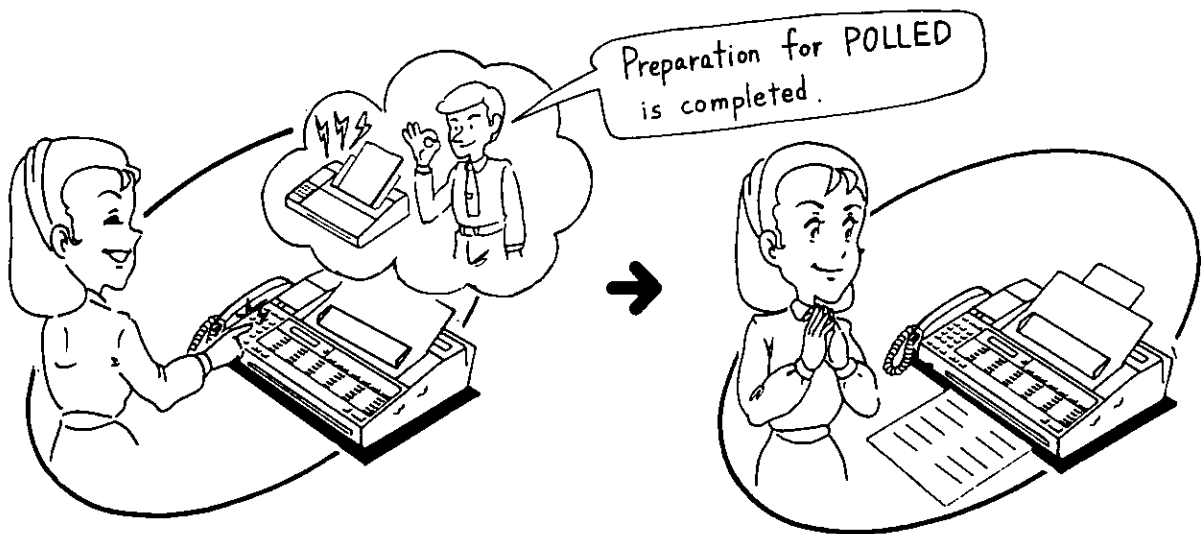

Single Station Polling

The following procedure lets you poll one station.

1

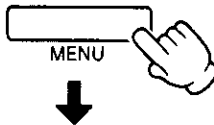

Press **MENU** 3 times.
 •The POLLING indicator will light.
 •This display will appear.

POLLING [1. OFF 2. ON
 3. XMT & POLL 4. POLLED]

ABC 2

Press "2".

POLLING ON
 PRESS SET KEY

SET

Press **SET**.

ENTER PHONE NUMBER
 = [01]

2

Example: The polled station is the ONE-TOUCH station 8.

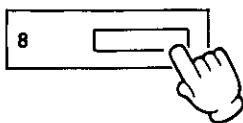

Enter the facsimile telephone number by using the One-Touch dialing, Speed dialing or a full number.

ENTER PHONE NUMBER
 =<S08> [01]

— dialed number or station name



Press **SET** twice.
 •When you use a full number, press the SET button once.

DELAYED POLL=OFF
 [1. OFF 2. ON]

3

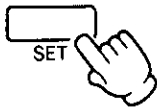

Press **SET**.

- If you want to perform the delayed polling, see page 1-31.

PRESS
[START/COPY] KEY

4

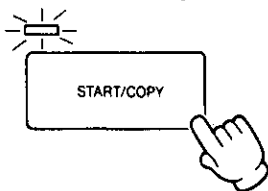

Press **START/COPY**.

- Polling will be performed.

DIALING <POLL>
TO: XXXXXXXX



POLLING P1
FROM: XXXXXXXX

— dialed number or
station name

NOTE:

- For successful polling, the polled station must make preparations. Refer to page 1-24.
- If the polled station is busy or there is no answer, the unit will automatically redial the number up to 6 times within a 10-minute period. If you receive or make another call during automatic redial period, the redial will be canceled.

POLLING (CONT.)

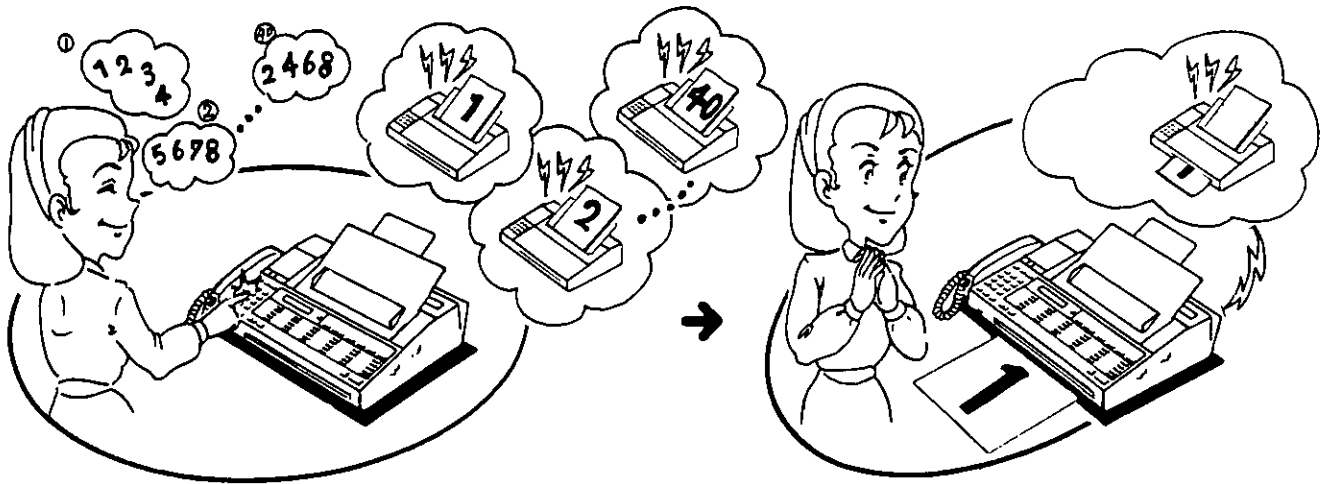

Multi Station Polling

If you want to poll two or more stations, you can poll up to 40 stations in one operation. However, you must use ONE-TOUCH and/or SPEED DIAL stations.

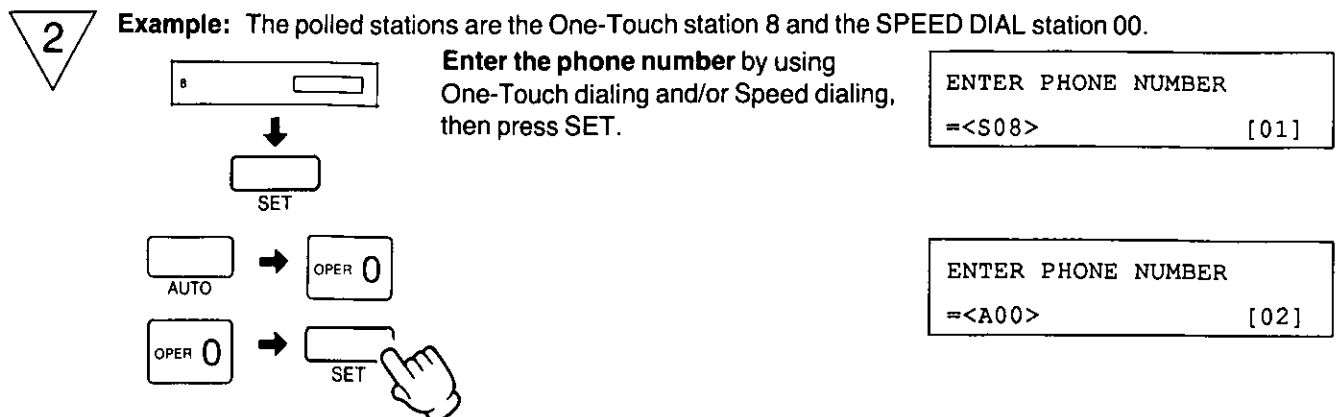
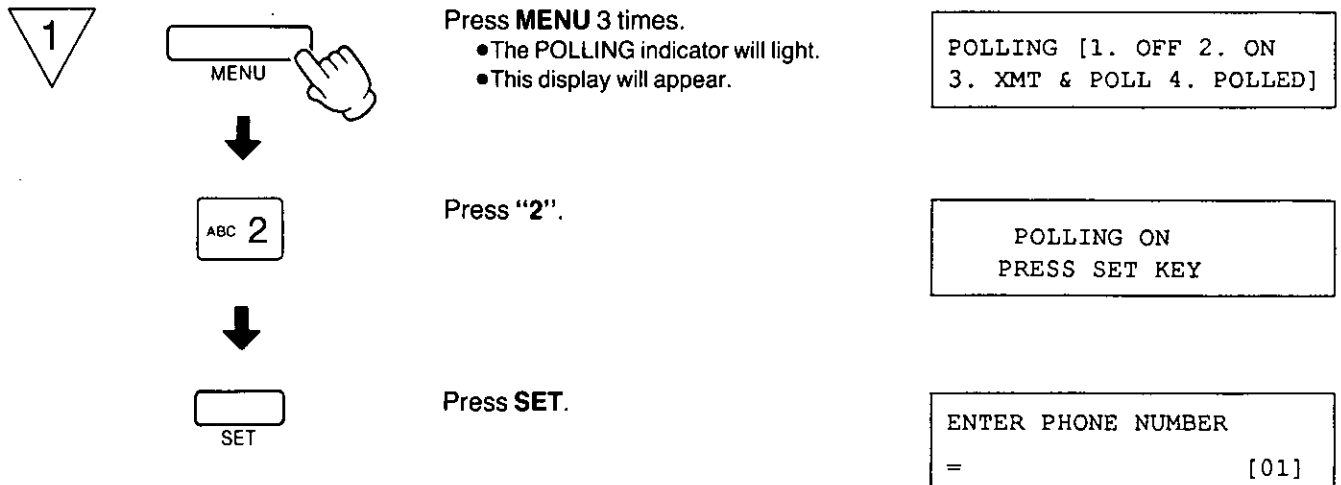

POLLING



3

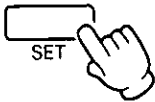

Press **SET**.

- If you want to perform the delayed polling, see page 1-31.

DELAYED POLL=OEF
[1. OFF 2. ON]



Press **SET**.

PRESS
[START/COPY] KEY

4

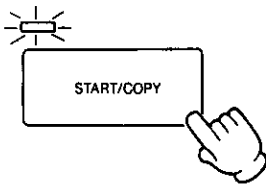

Press **START/COPY**.

- Polling will be performed.

DIALING <POLL>
TO: XXXXXXXX



POLLING P1
FROM: XXXXXXXX

NOTE:

- For successful polling, the polled station must make preparations. Refer to page 1-24.
- If one of the polled stations is busy or there is no answer, the station is skipped. Then the unit will automatically dial the next selected station. The skipped station(s) will be redialed 6 times after all selected stations have been called.

POLLING (CONT.)

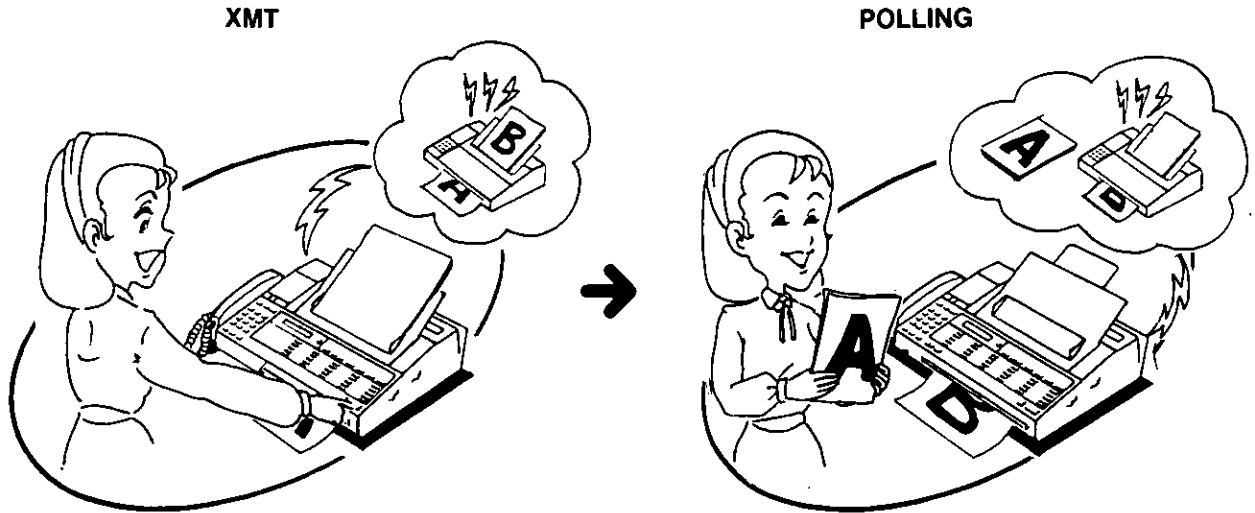

Turnaround Polling

Turnaround polling is a combination function, and you do two operations automatically with making one call. First, the unit will transmit a document to a station, and then it will poll the same station.

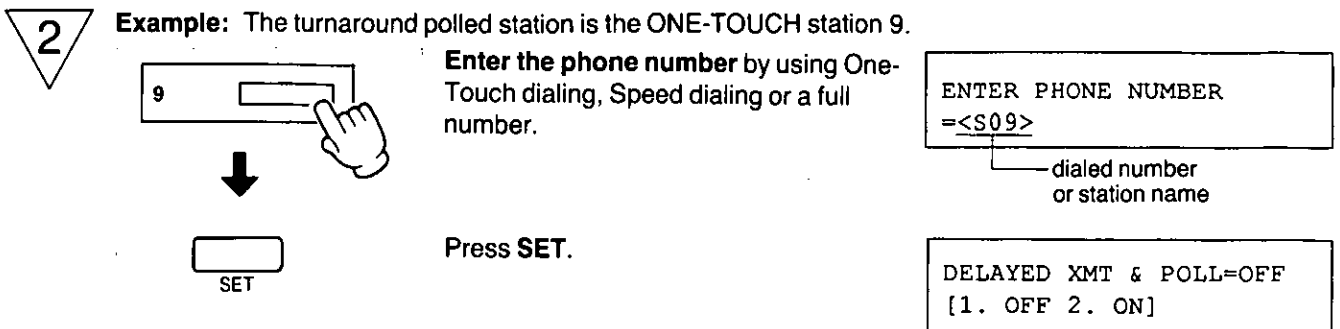
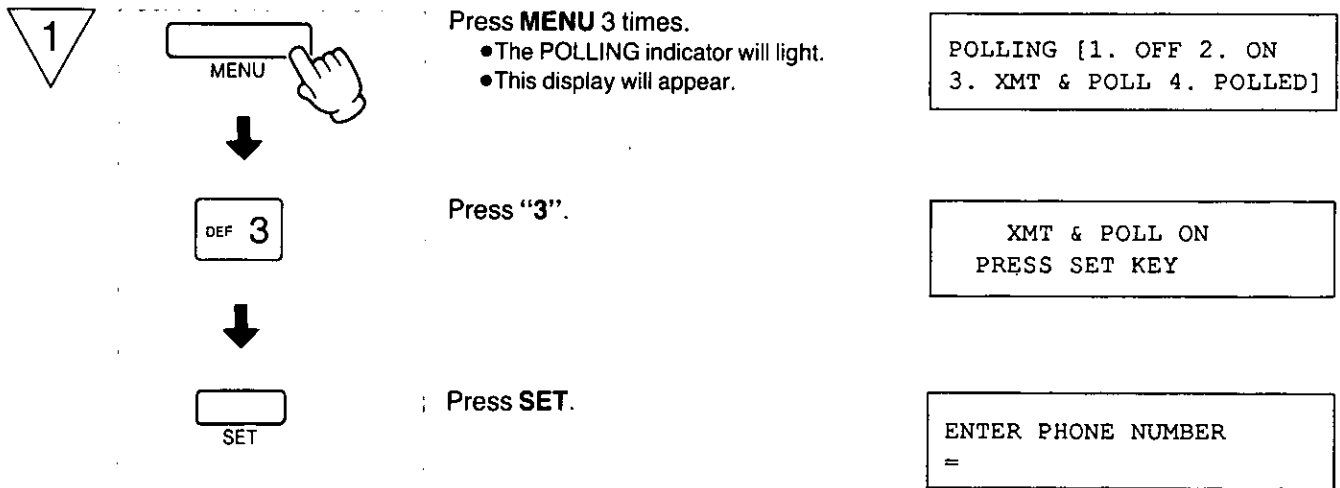

3

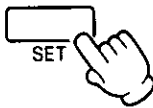

Press **SET**.

- If you want to perform the delayed turnaround polling, see page 1-33.

INSERT DOCUMENT
FACE DOWN

4

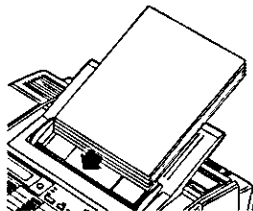

Insert a document **FACE DOWN**.

PRESS
[START/COPY] KEY

5

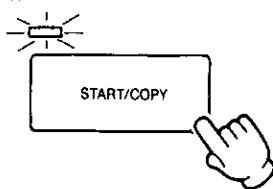

Press **START/COPY**.

- The documents will be transmitted.

DIALING <XMT & POLL>
TO: XXXXXX

dialed number or
station name

After the transmission, the unit will automatically switch to polling mode and poll the remote station.

POLLING
FROM: XXXXXXXX

NOTE:

- For successful polling, the polled station must make preparations. Refer to page 1-24.

POLLING (CONT.)

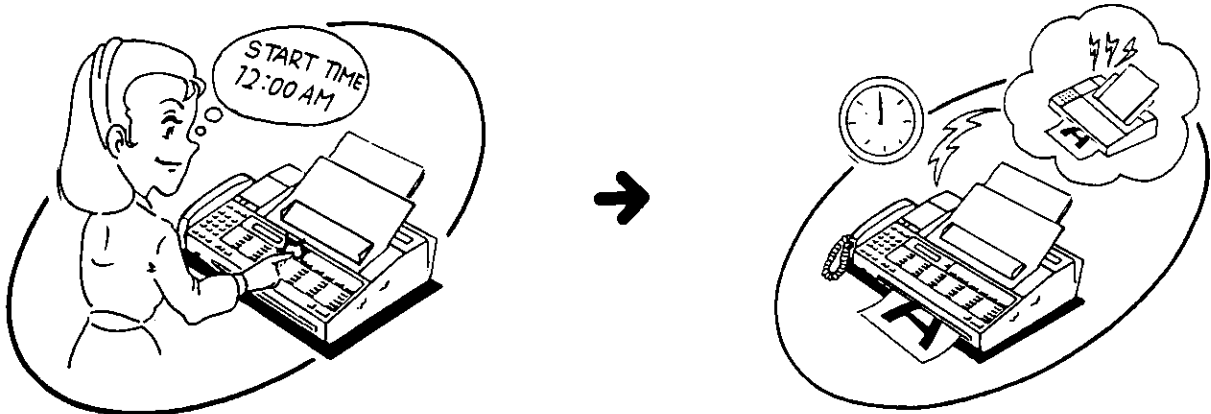

Delayed Polling

By programming the unit with a starting time and a facsimile telephone number, you can automatically perform polling function. This operation can be reserved to take place up to 24 hours after setting the timer. If you enter a full number, you poll single station alone.

1

MENU

Press **MENU** 3 times.

- The POLLING indicator will light.
- This display will appear.

POLLING [1. OFF 2. ON
3. XMT & POLL 4. POLLED]

↓

ABC 2

Press "2".

POLLING ON
PRESS SET KEY

↓

SET

Press **SET**.

ENTER PHONE NUMBER
= [01]

2

Example: The polled station is the One-Touch station 8.

8

Enter the phone number by using One-Touch dialing, Speed dialing or a full number.

ENTER PHONE NUMBER
=<S08> [01]

└──────────┘
dialed number

↓

SET

Press **SET** twice.

- If you want to add more stations, repeat step 2.

DELAYED POLL=OFF
[1. OFF 2. ON]

3

Example: The starting time is 8:00 PM.

Press "2", then press SET.

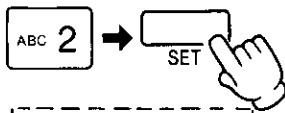

SET POLLING TIME
12:00 AM [*=AM #=PM]

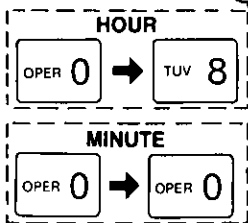

Enter the time at which the fax is to be transmitted.

•Press "*" or "#" to select AM/PM mode.

SET POLLING TIME
08:00 PM [*=AM #=PM]

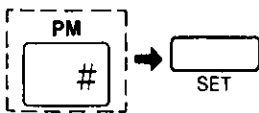

Press SET.

THU JUN29 3:00PM 00
POLLING AT 8:00PM

NOTE:

- Automatic and manual reception, transmission and copying function can be performed when delayed polling is set.
- If there is no answer or the line is busy when performing the delayed polling, the unit will automatically redial the number, up to 6 times within a 10-minute period.
- You cannot set a new Delayed Polling before receiving documents reserved by the previous Delayed Polling setting. Otherwise the previous setting will be overridden.

POLLING (CONT.)

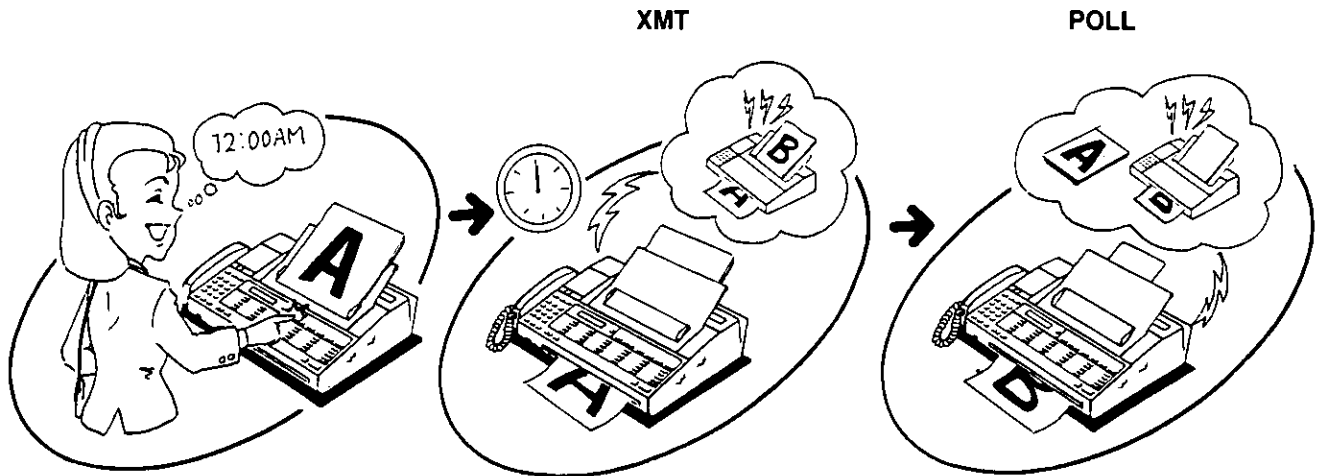

Delayed Turnaround Polling

By programming the unit with a starting time and a facsimile telephone number, you can automatically perform turnaround polling function. This operation can be reserved to take place up to 24 hours after setting the timer.

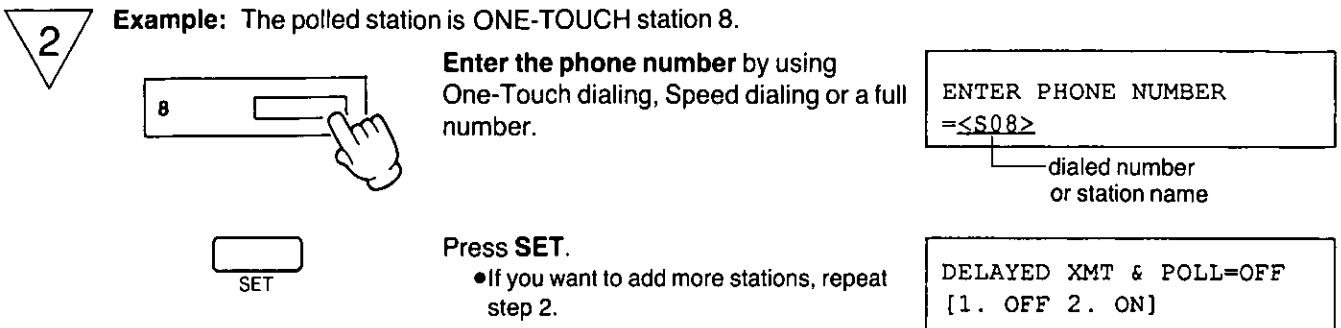
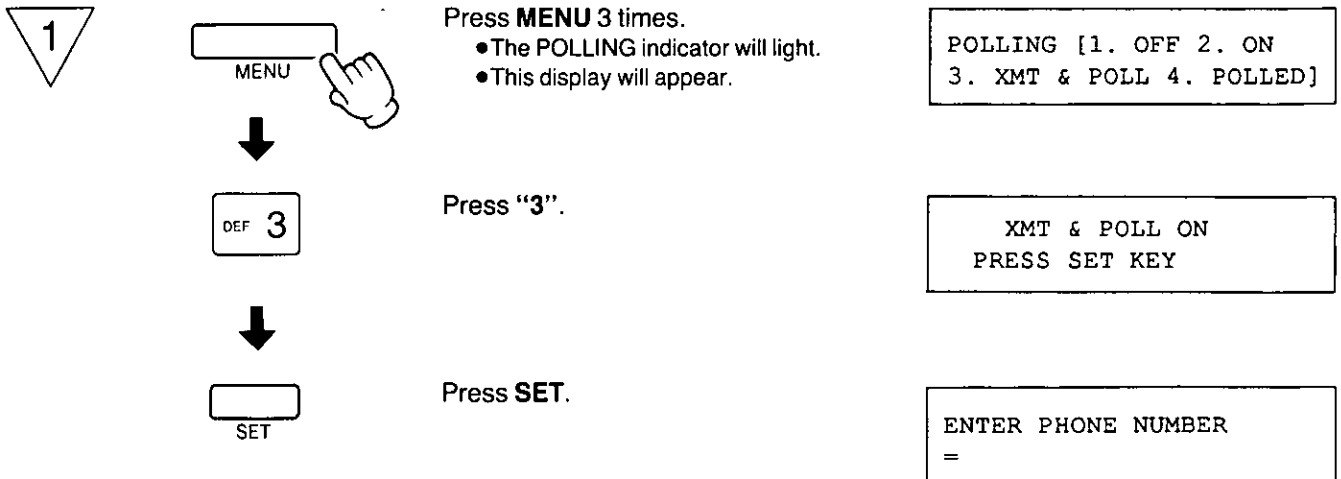

3

Example: The starting time is 8:00 PM.

Press "2", then press **SET**.

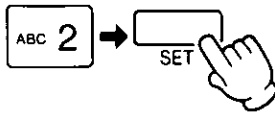

```
SET START TIME
12:00 AM [*=AM #=PM]
```

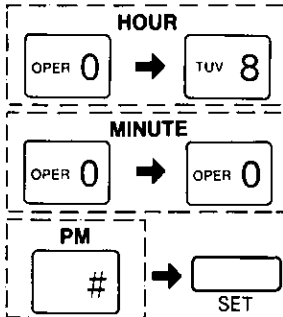

Enter the time at which the fax is to be transmitted.

•Press "*" or "#" to select AM/PM mode.

```
SET START TIME
08:00 PM [*=AM #PM]
```

Press **SET**.

```
INSERT DOCUMENT
FACE DOWN
```

4

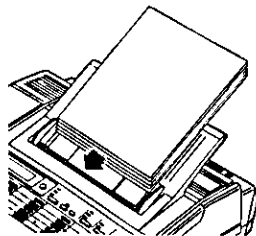

Insert a document FACE DOWN.

```
THU JUN 29 05:00 PM 00
XMT&POLL AT 8:00PM
```

NOTE:

- Automatic and manual reception, transmission and copying function can be performed when delayed turnaround polling is set.
- If there is no answer or the line is busy when performing the delayed turnaround polling, the unit will automatically redial the number, up to 6 times within a 10-minute period.
- You cannot set a new Delayed Turnaround Polling before the previous Delayed Turnaround Polling is performed. Otherwise the previous setting will be overridden.

PROGRAMMING AUTOMATIC DIALING NUMBERS

Programming One-Touch Dialing Numbers

You can program up to 24 facsimile telephone numbers and station names. Telephone numbers may be programmed up to 30 digits long. Station names may be programmed up to 16 alphanumeric characters (including symbols).

Example:

Program the facsimile number 123-4567 and station name into the station 7.

1

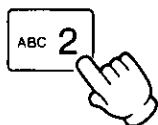
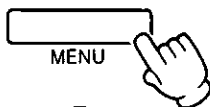

Press **MENU** 4 times.

- The PROGRAM indicator will light.
- This display will appear.

PROGRAM [1. DATE 2. TEL
3. SYSTEM 4. REPORT]

Press "2".

SELECT AUTO OR
ONE TOUCH KEY

2

Example: Program the facsimile number 123-4567 into the station 7.

Press a **ONE TOUCH** station.

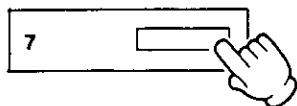

ENTER PHONE NO. <S07>
=

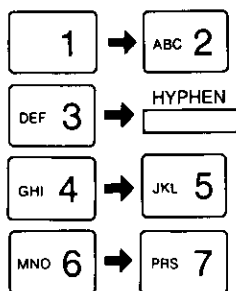

Enter the facsimile telephone number.

- To correct an error while programming; press the CLEAR button, and then enter correct input.
- Pressing the HYPHEN button once counts as 2 digits.

ENTER PHONE NO. <S07>
=123-4567

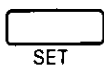

Press **SET** to store it into memory.

ENTER NAME
=

3

Example: Program the station name into the station 7.

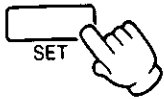

Enter the station name using the ONE-TOUCH station (as character key) and the dial keypad.

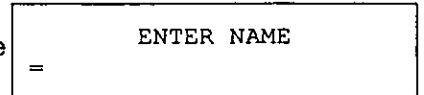

- Refer to "How to Use the Character Keys" on page 19 in INSTALLATION MANUAL.

Press **SET** to store it into memory.

- To enter facsimile number and station name in succession; repeat steps 2 and 3.

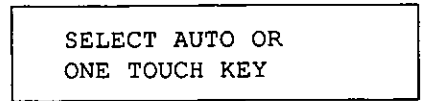

4



After programming all the numbers, press **MENU** again.

- The PROGRAM indicator will go out.

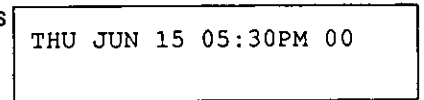

■ To enter the station name, use the character (station) keys on the Memory card and 0 through 9, * and # on the dial keypad. But you cannot use the SECRET key.

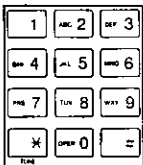

Dial Keypad

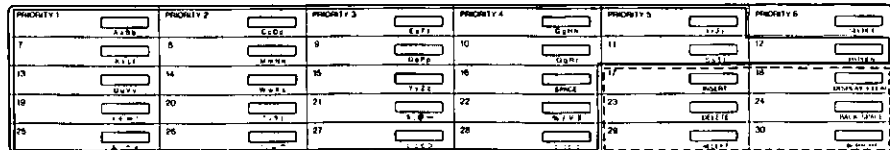

Character keys

Command keys

PROGRAMMING AUTOMATIC DIALING NUMBERS (cont.)

Programming Speed Dialing Numbers

The unit allows keys "0" to "9" on the dial pad to be used for an additional 100 memory stations. These stations can be accessed by dialing two digits ("00" through "99"). Telephone numbers may be programmed up to 30 digits long. Station names may be programmed up to 16 alphanumeric characters (including symbols).

Example:

Program the facsimile number 987-6543 and station name into the station 00.

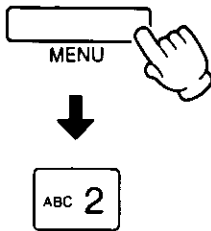

Press **MENU** 4 times.

- The PROGRAM indicator will light.
- This display will appear.

PROGRAM [1. DATE 2. TEL
3. SYSTEM 4. REPORT]

Press "2".

SELECT AUTO OR
ONE TOUCH KEY



Example: Program the facsimile number 987-6543 into the station 00.

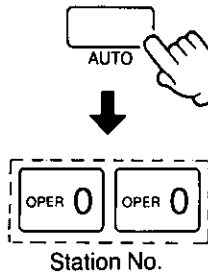

Press **AUTO**, then enter the station number (00 to 99).

ENTER PHONE NO. <A00>
=

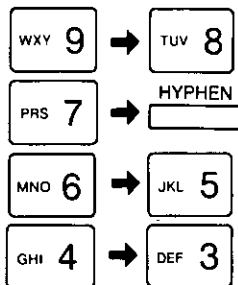

Enter the telephone (or facsimile) number.

- Pressing the HYPHEN button once counts as 2 digits.

ENTER PHONE NO. <A00>
=987-6543



Press **SET** to store it into memory.

ENTER NAME
=

3

Example: Program the station name into station 00.

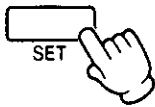

Enter the station name using the ONE TOUCH station (as character key) and the dial keypad.

- Refer to "How to Use the Character Keys" on page 19 in INSTALLATION MANUAL.

Press **SET** to store it into memory.

- To enter number and station name in succession; repeat steps 2 and 3.

ENTER NAME
=

SELECT AUTO OR ONE TOUCH KEY

4

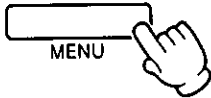

After programming all the numbers, press **MENU** again.

- The PROGRAM indicator will go out.

THU JUN 15 5:50PM 00

■ To enter the station name, use the character (station) keys on the Memory card and 0 through 9, * and # on the dial keypad. But you cannot use the SECRET key.



Dial Keypad

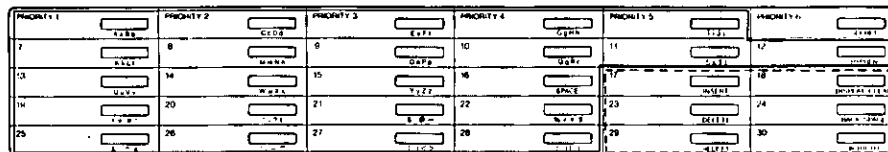

Character keys

Command keys

PROGRAMMING AUTOMATIC DIALING NUMBERS (cont.)

Programming as Secret Phone Numbers

This function is useful for keeping a facsimile/phone number (or a portion of it) secret, when you print out the list of facsimile/phone numbers.

Example:

Program the facsimile number 654-3210 and station name into the ONE TOUCH station 8 as a secret number.

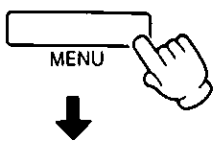

Press **MENU** 4 times.

- The PROGRAM indicator will light.
- This display will appear.

```
PROGRAM [1. DATE 2. TEL
3. SYSTEM 4. REPORT]
```



Press "2".

```
SELECT AUTO OR
ONE TOUCH KEY
```



Example: Program the facsimile number 654-3210 into the ONE TOUCH station 8 as a secret number.

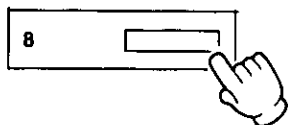

Press the **ONE TOUCH** station 8.

```
ENTER PHONE NO. <S08>
=
```

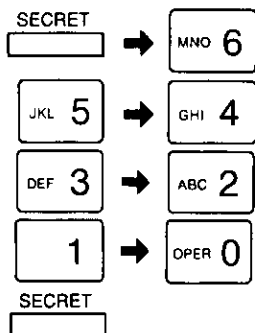

Press **SECRET** (PRIORITY 6), the telephone number, then press **SECRET**.

- To correct an error while programming; press the CLEAR button, and then enter the correct input.
- Pressing the SECRET button once counts as 2 digits.

```
ENTER PHONE NO. <S08>
=[6543210]
```



Press **SET** to store it into memory.

```
ENTER NAME
=
```

3

Example: Program the station name into the ONE TOUCH station 8.

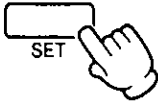

Enter the station name using the ONE-TOUCH station (as character key) and the dial keypad.

- Refer to "How to Use the Character Keys" on page 19 in INSTALLATION MANUAL.

Press **SET** to store it into memory.

- To enter number and station name in succession; repeat steps 2 and 3.

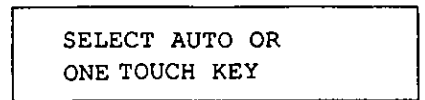
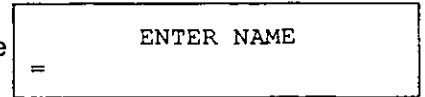

4

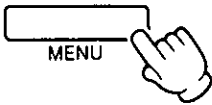

After programming all the numbers, press **MENU** again.

- The PROGRAM indicator will go out.

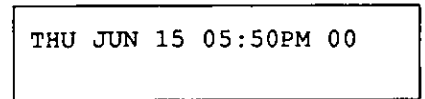

- To enter the station name, use the character (station) keys on the Memory card and 0 through 9, * and # on the dial keypad. But you cannot use the SECRET key.

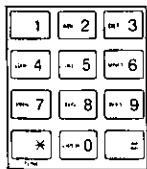

Dial Keypad

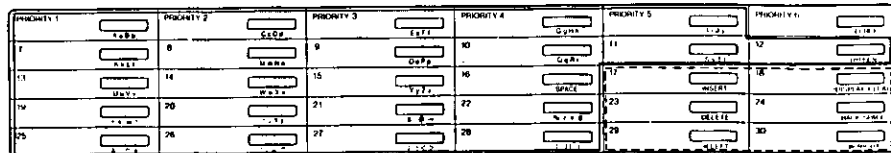

Character keys

Command keys

USING THE PRIORITY BUTTONS

The unit has 6 PRIORITY buttons. These buttons can store communications parameters (XMT, POLL, XMT & POLL) and starting time (Delayed communications) as well as a phone number in one station. This is very useful when you have to transmit or poll documents frequently to specific phone numbers.

You may program a desired function described below into a PRIORITY button. Programming and Calling are explained after this page.

- One-Touch Dialing (page 1-5)
- Delayed Transmission (page 1-9)
- Single Station Polling (page 1-25)
- Multi Station Polling (page 1-27)
- Turnaround Polling (page 1-29)

1

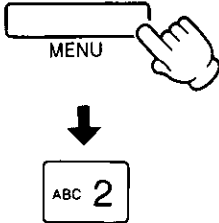

Press **MENU** 4 times, then press "2".
 • The PROGRAM indicator will light.

PROGRAM [1. DATE 2. TEL
 3. SYSTEM 4. REPORT]

SELECT AUTO OR
 ONE TOUCH KEY

2

Example: Program into a PRIORITY 1.

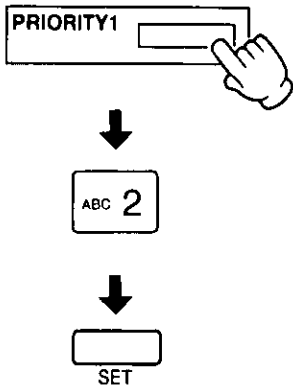

Press a **PRIORITY** (#1 through #6).

Press "2", then press **SET**.
 • If you use this button as an One-Touch station, press "1" instead of "2", then enter the phone number and station name. Refer to page 1-35.

PRIO. 1 MODE=DIAL
 [1. DIAL 2. PROG.]

PRIO. 1 MODE=PROG.
 [1. DIAL 2. PROG.]

MODE=XMT [1. XMT
 2. POLL 3. XMT&POLL]

3

Press "1", "2" or "3" as needed, then press **SET**.

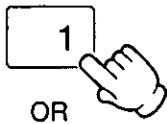

Ⓐ Press "1" for **XMT**.
 (Go to page 1-43.)

MODE=XMT [1. XMT
 2. POLL 3. XMT&POLL]

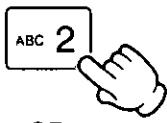

Press "2" for **POLL**.
 Ⓑ (Go to page 1-44 for single polling.)
 Ⓒ (Go to page 1-45 for multi polling.)

MODE=POLL [1. XMT
 2. POLL 3. XMT&POLL]

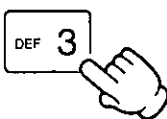

Ⓓ Press "3" for **XMT & POLL**.
 (Go to page 1-47.)

MODE=XMT&POLL [1. XMT
 2. POLL 3. XMT&POLL]

Programming Flowchart

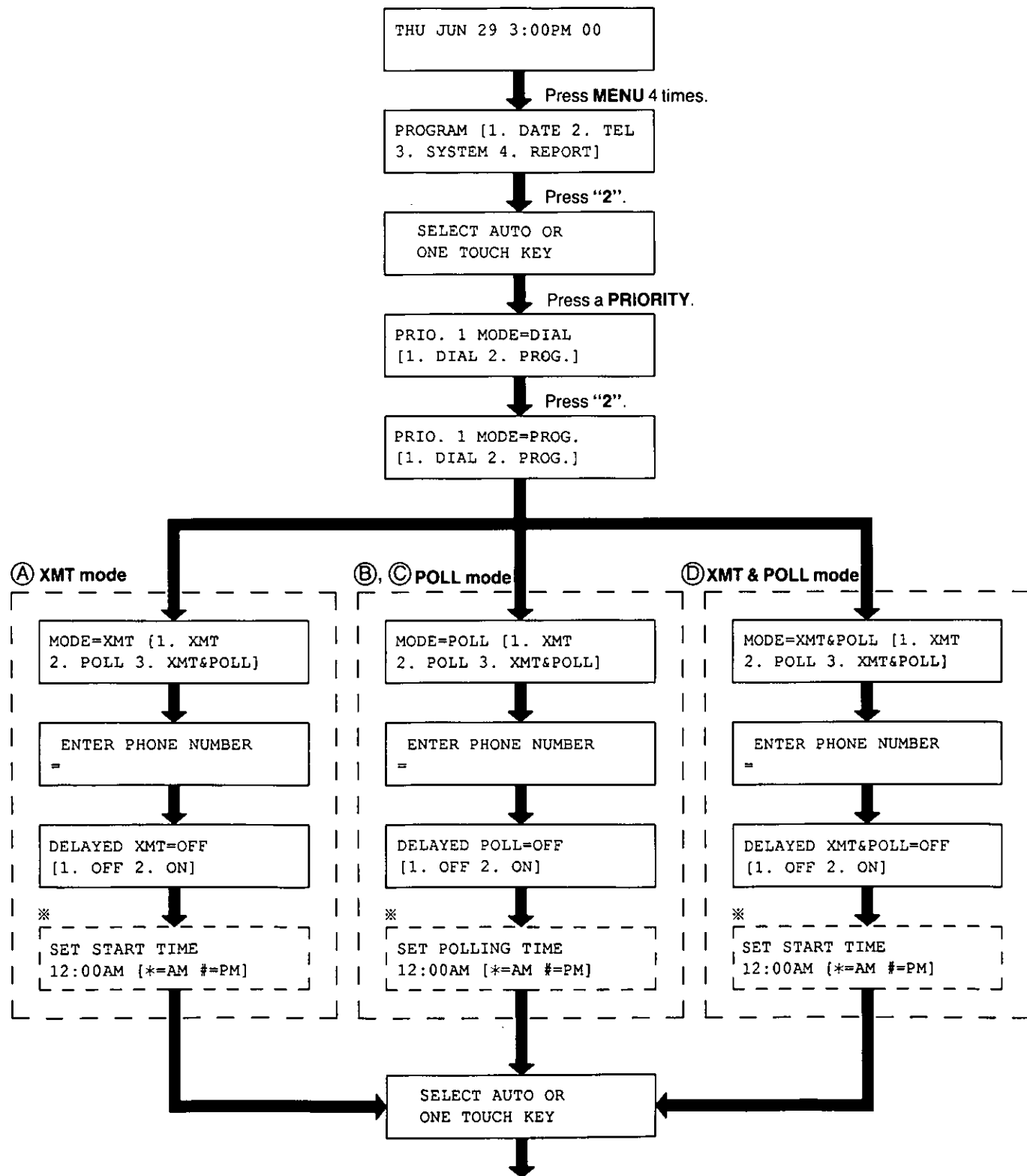

※When Delayed Communication is set to OFF, "SET START TIME" is not displayed.

USING THE PRIORITY BUTTONS (CONT.)

A: Programming Delayed XMT (Transmission)

4A

Enter phone number using one of the following ways.

■ **One-Touch dialing:**

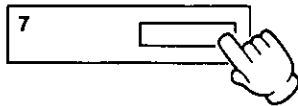

Press a **ONE-TOUCH** station.
(e.g. If the station number is 7.)

ENTER PHONE NUMBER
=<S07>

■ **Speed dialing:**

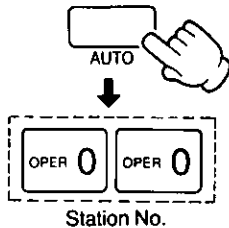

Press **AUTO** and **station number**
(2 digits).
(e.g. If the station number is 00.)

ENTER PHONE NUMBER
=<A00>

■ **Manual dialing:**

Dial the number with dial keypad.
(e.g. If the phone number is 1234567.)

ENTER PHONE NUMBER
=1234567

5A



Press **SET**.

DELAYED XMT=OFF
[1. OFF 2. ON]

6A

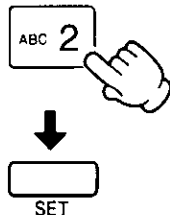

Press "2", then press **SET**.

DELAYED XMT=ON
[1. OFF 2. ON]

SET START TIME
12:00AM [*=AM #=PM]

7A

Example: The starting time is 11:00 PM.

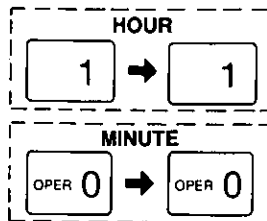

Enter starting time, then press **SET**.

SET START TIME
11:00PM [*=AM #=PM]

SELECT AUTO OR
ONE TOUCH KEY

8A

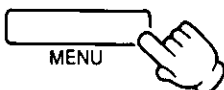

Press **MENU** to end the operation.

THU JUN 29 3:00PM 00

B: Programming POLL (Single Polling)

4B

Enter phone number using one of the following ways.

■ **One-Touch dialing:**

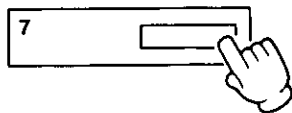

Press a **ONE-TOUCH** station.
(e.g. If the station number is 7.)

```
ENTER PHONE NUMBER
=<S07> [01]
```

■ **Speed dialing:**

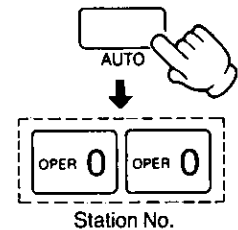

Press **AUTO** and **station number**
(2 digits).
(e.g. If the station number is 00.)

```
ENTER PHONE NUMBER
=<A00> [01]
```

■ **Manual dialing:**

Dial the number with dial keypad.
(e.g. If the phone number is 1234567.)

```
ENTER PHONE NUMBER
=1234567
```

5B



Press **SET**.

```
DELAYED POLL=OFF
[1. OFF 2. ON]
```

6B

Select desired mode.

■ **If you do not need to set the timer:**

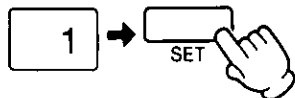

Press "1", then press **SET**.

```
SELECT AUTO OR
ONE TOUCH KEY
```

■ **If you want to perform delayed polling;**

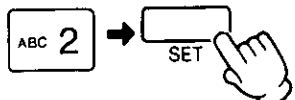

Press "2", then press **SET**. And enter the
desired time, then press **SET**.
(e.g. If the starting time is 11:00 PM.)

```
DELAYED POLL=ON
[1. OFF 2. ON]
```

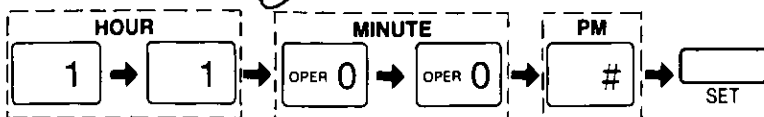

```
SET POLLING TIME
11:00PM [*=AM #=PM]
```

7B



Press **MENU** to end the operation.

```
THU JUN 29 3:00PM 00
```

USING THE PRIORITY BUTTONS (CONT.)

C: Programming POLL (Multi Polling)

Before programming multi polling, the desired phone numbers must be stored into ONE-TOUCH stations and/or SPEED DIALING stations.

4C

Enter phone numbers using one of the following ways.

■ One-Touch dialing:

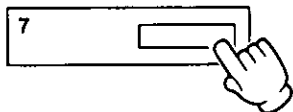

Press a **ONE-TOUCH** station.
(e.g. If the station number is 7.)

ENTER PHONE NUMBER
=<S07> [01]

■ Speed dialing:

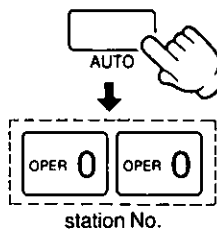

Press **AUTO** and **station number**
(2 digits).
(e.g. If the station number is 00.)

ENTER PHONE NUMBER
=<A00> [01]

5C



Press **SET**.

Repeat steps (4C) and (5C) for storing
phone numbers (up to 40 stations).

ENTER PHONE NUMBER
= [02]

:

ENTER PHONE NUMBER
= [29]

:

ENTER PHONE NUMBER
= [40]

6C



After storing all the numbers, press **SET**
again.

DELAYED POLL=OFF
[1. OFF 2. ON]

7C

Select desired mode.

■ If you do not need to set the timer;

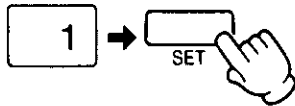

Press "1", then press SET.

SELECT AUTO OR
ONE TOUCH KEY

■ If you want to perform delayed multi polling;

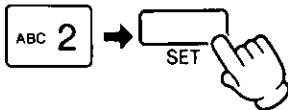

Press "2", then press SET. And enter the desired time, then press SET.
(If the starting time is 11:00 P.M.)

DELAYED POLL=ON
[1. OFF 2. ON]

SET POLLING TIME
11:00AM [1. *=AM 2.#=PM]

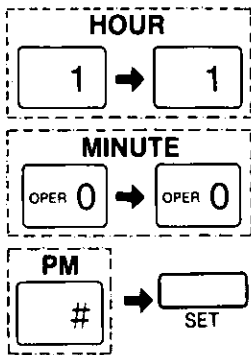

8C



Press MENU to end the operation.

THU JUN 29 3:00PM 00

USING THE PRIORITY BUTTONS (CONT.)

D: Programming XMT & POLL (Turnaround Polling)

4D

Enter phone number using one of the following ways.

■ **One-Touch dialing:**

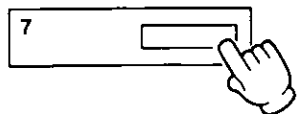

Press **One-Touch** station.
(e.g. If the station number is 7.)

ENTER PHONE NUMBER
=<S07>

■ **Speed dialing:**

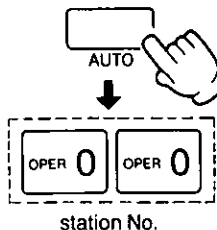

Press **AUTO** and **station number**
(2 digits).
(e.g. If the station number is 00.)

ENTER PHONE NUMBER
=<A00>

■ **Manual dialing:**

Dial the number with dial keypad.
(e.g. If the phone number is 1234567.)

ENTER PHONE NUMBER
=1234567

5D

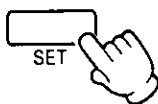

Press **SET**.

DELAYED XMT&POLL=OFF
[1. OFF 2. ON]

6D

Select desired mode.

■ **If you do not need to set the timer;**

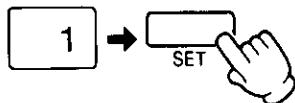

Press "1", then press **SET**.

SELECT AUTO OR
ONE TOUCH KEY

■ **If you want to perform delayed polling;**

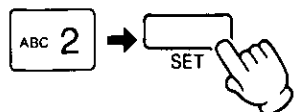

Press "2", then press **SET**. And enter
the desired time, then press **SET**.
(If the starting time is 11:00 P.M.)

DELAYED XMT&POLL=ON
[1. OFF 2. ON]

SET START TIME
11:00PM [*=AM #=PM]

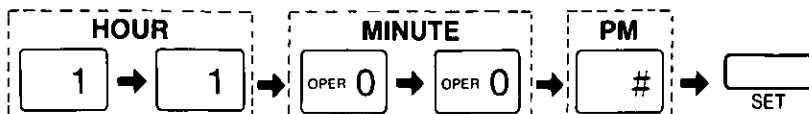

7D



Press **MENU** to end the operation.

THU JUN 29 3:00PM 00

Calling with Priority Buttons

Delayed XMT

Example: Using PRIORITY button 1 to stores "XMT at 11:00 PM."

PRIORITY1



Insert a document FACE DOWN, then press the desired PRIORITY.

When the programmed time comes, the unit starts transmission automatically.

■ **To cancel;**
Press **STOP**, then press "1".

```
THU JUN 29 3:00PM 00
XMT AT 11:00PM
```

```
CANCEL DELAYED
XMT? [1. YES 2. NO]
```

POLLING

Example: Using PRIORITY button 2.

PRIORITY2



Press the desired PRIORITY.

The unit starts polling.

■ **To cancel;**
Press **STOP**.

Delayed polling:
When the programmed time comes, the unit starts polling automatically.

■ **To cancel;**
Press **STOP**, then press "1".

```
DIALING <POLL>
TO: XXXXXXXX
```

Station name
or dialing number

```
THU JUN 29 3:00PM 00
USER STOPPED
```

```
THU JUN 29 3:00PM 00
POLLING AT 11:00PM
```

```
CANCEL DELAYED
POLLING? [1. YES 2. NO]
```

USING THE PRIORITY BUTTONS (CONT.)

Calling with Priority Buttons (cont.)

XMT & POLL

Example: Using PRIORITY button 3.

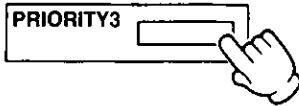

Insert a document **FACE DOWN**,
then press the desired **PRIORITY**.

The unit starts turnaround polling.

■ **To cancel;**
Press STOP.

Delayed polling:

When the programmed time comes, the
unit starts polling automatically.

■ **To cancel;**
Press STOP, then press "1".

```
DIALING <XMT&POLL>  
TO:
```

```
THU JUN 29 3:00PM 00  
USER STOPPED
```

```
THU JUN 29 3:00PM 00  
XMT&POLL AT 11:00PM
```

```
CANCEL DELAYED XMT&  
POLL? [1. YES 2. NO]
```

NOTE:

- Automatic and manual reception, transmission and copying function can be performed when delayed transmission is set. To copy another document, remove the document on the tray and replace it when you finish.
- If the line is busy when performing the delayed transmission, the unit will automatically redial the number, up to 6 times within a 10-minute period.
- When you use the PRIORITY button as a One-Touch station button, refer to page 1-5.

PASSWORD COMMUNICATIONS

This feature is effective only between Panasonic compatible machines.

Password communications helps you to transmit a document to the specific station. It will also be helpful in preventing your unit receiving from unauthorized station.

When password communications is used, the identical main password (a 4-digit number) must be programmed on both sides of the line. The unit checks the password either before transmitting or receiving a document.

The KX-F220 has two password communications functions. They are TX (transmission) password check mode and RX (receiving) password check mode.

TX Password Check:

This function checks the password before transmitting a document. If the password sent from the other KX-F220 does not match with the one programmed in your KX-F220, transmission will be prohibited.

23. TX PASSWORD CHECK =OFF [1. OFF 2. ON]
--

RX Password Check:

This function checks the password before receiving a document. If the password sent from the other KX-F220 does not match with the one programmed in your KX-F220, receiving will be prohibited.

24. RX PASSWORD CHECK =OFF [1. OFF 2. ON]
--

NOTE:

The Polling Function always performs independently, not related to the password communications feature.

PASSWORD COMMUNICATIONS (CONT.)

Information of the Password Communications

Before using password communications, check that your password and the other station's password are identical and you set "SEND PASSWORD" to ON.

■ When you want to transmit a document only to specific people (TX password check mode):

Set "TX PASSWORD CHECK" to ON. (See the Table 1 below.)

FUNCTION	YOUR KX-F220	OTHER KX-F220
SEND PASSWORD	ON	ON
TX PASSWORD CHECK	ON	ON/OFF
RX PASSWORD CHECK	OFF	ON/OFF

<Table 1>

```
THU JUN29 3:00PM 00
TX PASSWORD CHECK ON
```

- Your unit transmits a document only when the correct password is received.

■ When you want to receive a document only from specific people (RX password check mode):

Set "RX PASSWORD CHECK" to ON. (See the Table 2 below.)

FUNCTION	YOUR KX-F220	OTHER KX-F220
SEND PASSWORD	ON	ON
TX PASSWORD CHECK	OFF	ON/OFF
RX PASSWORD CHECK	ON	ON/OFF

<Table 2>

```
THU JUN29 3:00PM 00
RX PASSWORD CHECK ON
```

- Your unit receives a document only when the correct password is received.

■ When you want to send a document to and receive a document from specific people.
(TX password check and RX password check mode):

Set "TX PASSWORD CHECK" and "RX PASSWORD CHECK" to ON. (See the Table 3 below.)

FUNCTION	YOUR KX-F220	OTHER KX-F220
SEND PASSWORD	ON	ON
TX PASSWORD CHECK	ON	ON/OFF
RX PASSWORD CHECK	ON	ON/OFF

<Table 3>

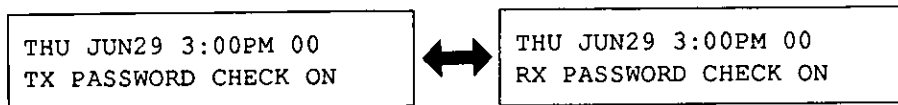

- Your unit transmits and receives a document only when the correct password is received.

■ When you want to have facsimile communications only within a group of people:

All the people in the group must set both "TX PASSWORD CHECK" and "RX PASSWORD CHECK" to ON.
(See the Table 4 below.)

FUNCTION	YOUR KX-F220	OTHER KX-F220
SEND PASSWORD	ON	ON
TX PASSWORD CHECK	ON	ON
RX PASSWORD CHECK	ON	ON

<Table 4>

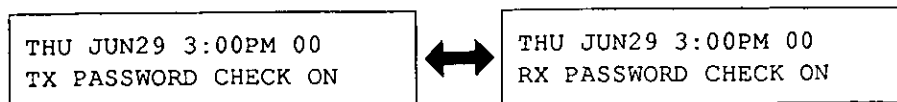

- Only people who share the identical password can transmit and receive a document each other.

PASSWORD COMMUNICATIONS (CONT.)

Programming the Password Communications

1

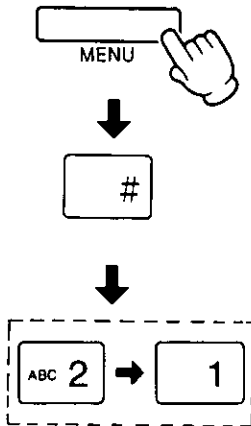

Press **MENU** 4 times.
 •The PROGRAM indicator will light.
 •This display will appear.

PROGRAM [1. DATE 2. TEL
 3. SYSTEM 4. REPORT]

Press "#", then press "21".

21. MAIN PASSWORD
 =0000

2

Example: Password is 1234.

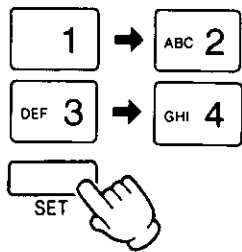

Enter your password (4 digits), then press **SET**.

21. MAIN PASSWORD
 =1234

•0000 is not effective as a password.

PROGRAM [1. DATE 2. TEL
 3. SYSTEM 4. REPORT]

3

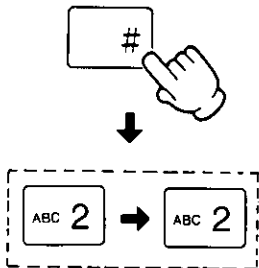

Press "#", then press "22".

22. SEND PASSWORD=OFF
 [1. OFF 2. ON]

4

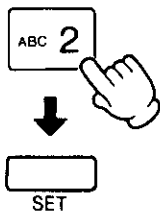

Press "2", then press **SET**.

22. SEND PASSWORD=ON
 [1. OFF 2. ON]

PROGRAM [1. DATE 2. TEL
 3. SYSTEM 4. REPORT]

5



Press "#", then press "23".

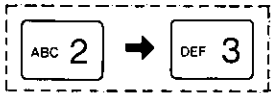

23. TX PASSWORD CHECK
=OFF [1. OFF 2. ON]

6

■ To set "TX PASSWORD CHECK" on;

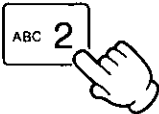

Press "2".

23. TX PASSWORD CHECK
=ON [1. OFF 2. ON]

■ To set "TX PASSWORD CHECK" off;

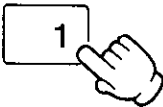

Press "1".

23. TX PASSWORD CHECK
=OFF [1. OFF 2. ON]

7

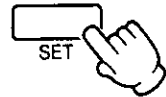

Press SET.

PROGRAM [1. DATE 2. TEL
3. SYSTEM 4. REPORT]

8

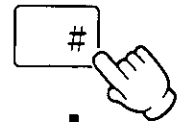

Press "#", then press "24".

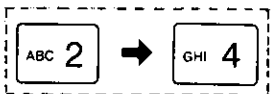

24. RX PASSWORD CHECK
=OFF [1. OFF 2. ON]

9

■ To set "RX PASSWORD CHECK" on;

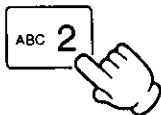

Press "2".

24. RX PASSWORD CHECK
=ON [1. OFF 2. ON]

■ To set "RX PASSWORD CHECK" off;

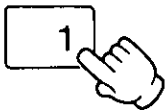

Press "1".

24. RX PASSWORD CHECK
=OFF [1. OFF 2. ON]

10



Press SET.

PROGRAM [1. DATE 2. TEL
3. SYSTEM 4. REPORT]



Press MENU to end the operation.

THU JUN 29 3:00PM 00

PASSWORD COMMUNICATIONS (CONT.)

Password Communications

Password communications is activated with the MAIN PASSWORD (refer to page 1-53). However, you may change or cancel the password temporarily by using MENU button (XMT RESERVATION, DELAYED XMT, and XMT & POLL) when "SEND PASSWORD" or "TX PASSWORD CHECK" is set to ON. This feature is useful when you need to transmit a document to a station which has a different password or no password programmed.

Example: Using XMT RESERVATION

<p>1</p>	<p>Insert a document FACE DOWN. Press MENU, then enter a phone number.</p>	<p>XMT RESERVATION ENTER PHONE NUMBER</p>
<p>2</p>	<p>Press SET.</p>	<p>PASSWORD=MAIN [* =MAIN #=NONE OR 4 DIGITS]</p>
<p>3</p> <p>■ To use the main password.</p> <p>■ To cancel the password temporarily.</p> <p>■ To change the password temporarily.</p>	<p>Press "*" to send the main password (programmed password).</p> <p>Press "#" to skip the password.</p> <p>When you need to send a different password, enter the numbers using dial keypad. (If the password is 5678.)</p>	<p>PASSWORD=NONE [* =MAIN #=NONE OR 4 DIGITS]</p> <p>PASSWORD=5678 [* =MAIN #=NONE OR 4 DIGITS]</p>
<p>4</p>	<p>Press SET.</p> <p>● The unit starts transmission.</p>	<p>DIALING <XMT> TO: <u>XXXXXXXX</u></p> <p style="text-align: right;">└─ Dialed number</p>

Programming Different Passwords into Priority Buttons

You may program different passwords into priority keys when "SEND PASSWORD" or "TX PASSWORD CHECK" is set to ON. This feature is useful when you frequently transmit a document to people who have a different password (including no password).

1 Program transmitting mode and the phone number you need.
(Refer to pages 1-41 to 1-47).

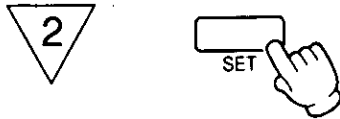

Press **SET**.

PASSWORD=MAIN [* =MAIN
#=NONE OR 4 DIGITS]

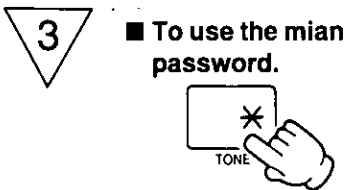

Press "*" to send the main password (programmed password).

■ To program no password.

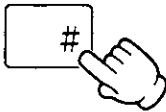

Press "#" to skip the password.

PASSWORD=NONE [* =MAIN
#=NONE OR 4 DIGITS]

■ To program a different password.

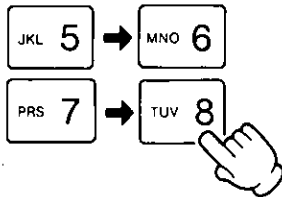

When you need to send a different password, enter the numbers using dial keypad.
(e.g. If the password is 5678.)

PASSWORD=5678 [* =MAIN
#=NONE OR 4 DIGITS]

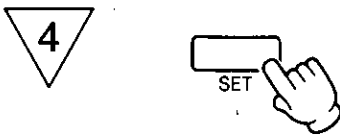

Press **SET** and go to the next step.
(Refer to pages 1-41 to 1-47.)

DELAYED XMT=OFF
[1. OFF 2. ON]

NOTE:

When a password is not programmed into a priority button, the main password is automatically sent if "SEND PASSWORD" is set to ON.

PRINTING REPORTS AND LISTS

Activity Report (JOURNAL Report)

The JOURNAL is a record of the last 30 transactions (transmission and receptions). When you set the JOURNAL to AUTO, it is printed automatically after every 30 transactions. It may also be printed on request.

This function has been preset to AUTO (Default).

Selection is as follows:

- AUTO Prints a report every 30 transactions automatically.
- MANUAL Prints a report of last 30 transactions.

```

***** JOURNAL *****
*                                     (1)      (2)                                     *
*                                     JUL. 29, 1989  3:16 PM                                     *
*      (3)      (4)      (5)      (6)      (7)      (8)      (9)                                     *
*      No.      OTHER FACSIMILE      START TIME      USAGE TIME      TX PAGES      RX PAGES      RESULT                                     *
*-----*-----*-----*-----*-----*-----*-----*
*      01      Panasonic C      JUL. 29  3:04PM      00' 31      01      00      OK      *
*      02      Panasonic C      JUL. 29  3:05PM      00' 39      00      01      OK      *
*      03      Panasonic A      JUL. 29  3:07PM      00' 19      00      00      NG(02)  *
*      04      Panasonic B      JUL. 29  3:08PM      00' 58      01      01      OK      *
*      05      Panasonic A      JUL. 29  3:10PM      00' 28      01      00      OK      *
*      06      1238756      JUL. 29  3:13PM      00' 35      00      00      NG(02)  *
*      07      Panasonic B      JUL. 29  3:15PM      00' 34      00      01      OK      *
*
*
*
*
*
*
*
*
*
*
*****
    
```

Explanation of JOURNAL

- | | |
|---|--|
| (1) Print date: Month/Date/Year | (5) Communication start time |
| (2) Print time: Hour:Minute | (6) Usage time: Minute' Seconds |
| (3) Communication number (up to 30) | (7) Number of pages transmitted successfully |
| (4) Dial number | (8) Number of pages recieved successfully |
| 5263057: The other party's number dialed manually is 5263057. | (9) Communication result |
| INCOMING: Document or telephone call is received. | OK: Successful communication |
| Company XXXXX: Station name | Numeral: Error code (See ERROR CODE below) |

CODE	DESCRIPTION	CODE	DESCRIPTION
01	When the power supply overheats. Allow unit to cool.	06	When the unit is out of paper. Check paper.
02	When transmission is interrupted by pushing the STOP/CLEAR button.	07	When the cover is opened. Check Cover Latch.
03	When a document is jammed or does not feed into the unit. Check paper path.	08	When the paper is jammed. Re-install the recording paper.
04	When transmission/reception error occurs.	09	When Password Communication failed. Confirm that your password corresponds to the other facsimile unit.
05	When the printhead overheats. Allow unit to cool.		

Setting JOURNAL Report

1



Press **MENU** 4 times.

- The PROGRAM indicator will light.
- This display will appear.

PROGRAM [1. DATE 2. TEL
3. SYSTEM 4. REPORT]

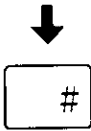

Press “#”, then press “04”.

4. JOURNAL=AUTO
[1. AUTO 2. MANUAL]

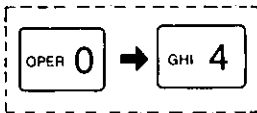

2

Press the buttons as follows.

■ To set the JOURNAL to AUTO

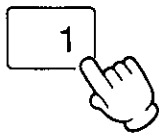

Press “1”.

- The Journal report will be automatically printed when the memory becomes full (30 transactions). The journal memory will then be cleared.

4. JOURNAL=AUTO
[1. AUTO 2. MANUAL]

■ To set the JOURNAL to MANUAL

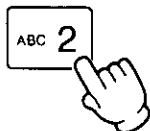

Press “2”.

- The Journal report will be stored until the memory becomes full. The oldest will be deleted.

4. JOURNAL=MANUAL
[1. AUTO 2. MANUAL]

3

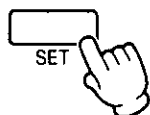

Press **SET** to store your selection.

PROGRAM [1. DATE 2. TEL
3. SYSTEM 4. REPORT]

4

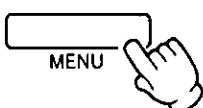

Press **MENU** to end the operation.

System Set Up List

***** SYSTEM SETUP LIST *****

```

#00 9/ 7/89 03:42PM
#01 YOUR LOGO =
#02 YOUR TELEPHONE NUMBER =
#03 LOGO POSITION = OUT
#04 PRINT JOURNAL = AUTO
#05 PRINT XMT REPORT = OFF
#06 MESSAGE OUT = OFF
    A = *** CONFIDENTIAL ***
    B = *** IMMEDIATE REPLY REQUESTED ***
    C =
#07 PAGE COUNTER = OFF
#08 REMOTE FAX ID = OFF
#09 REMOTE FAX ID NUMBER = 2222
#10 REMOTE ATAS ID = 111
#11 RECORDING TIME = VOX
#12 CPC MODE = A
#13 AUX LEADS = OUT
#14 DIAL PULSE = 10PPS
#15 TONE DETECT = OFF
#16 AUTO RECEIVE TIMER = OFF
    AUTO RECEIVE ON TIME = 12:00AM    AUTO RECEIVE OFF TIME = 12:00AM
#17 TX SPEED = 9600BPS
#18 RX SPEED = 9600BPS
#19 STAMP DEFAULT = OFF
#20 AUTO STANDBY = ON
#21 MAIN PASSWORD = 0000
#22 SEND PASSWORD = OFF
#23 TX PASSWORD CHECK = OFF
#24 RX PASSWORD CHECK = OFF
#25 POLLING PASSWORD = 0000
#26 SET DEFAULT = NO
#27 TEST (PRINT OR MOTOR)
< DELAYED MODE >
    DELAYED MODE = OFF
    PHONE NUMBER =
    PASSWORD = 0000
    START TIME = 12:00AM
  
```

Printing System Set Up List

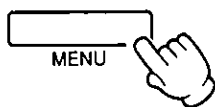

Press **MENU** 4 times.

- The PROGRAM indicator will light.
- This display will appear.

PROGRAM [1. DATE 2. TEL
3. SYSTEM 4. REPORT]



GHI 4

Press "4".

SELECT NO. [1. SYSTEM
2. TEL NO. 3. JOURNAL]



1

Press "1".

- The unit will start printing.

PRINTING SYSTEM LIST

PRINTING REPORTS AND LISTS (CONT.)

List of Stored Phone Numbers (TEL LIST)

TELEPHONE NUMBER LIST

< PRIORITY KEY LIST >

* PRIORITY 1 *

01 KEY MODE	= PROGRAM
02 MODE	= XPT
03 PHONE NUMBER	= T789
04 PASSWORD PROTECT	= NONE
05 PASSWORD	= 0000
06 DELAYED MODE	= ON
07 START TIME	= 12:00AM

* PRIORITY 2 *

01 KEY MODE	= PROGRAM
02 MODE	= POLL
03 PHONE NUMBER	= S07,S13,S19
04 PASSWORD PROTECT	= NONE
05 PASSWORD	= 0000
06 DELAYED MODE	= ON
07 START TIME	= 11:00AM

TELEPHONE NUMBER LIST

< STATION KEY LIST >

PHONE NUMBER	NAME	PHONE NUMBER	NAME
07 T123-4567	Panasonic	19 T531-6900	Karl Louis
08 T789-2694	Jane	20	
09		21	
10		22	
11		23	
12		24	
13 T592-1397	Matushita	25	
14		26	
15		27	
16		28	
17		29	
18		30	

< AUTO KEY LIST >

PHONE NUMBER	NAME	PHONE NUMBER	NAME
00 T312-6473	Jorge Loucus	50 T430-0305	National
01		51	
02		52	
03		53	
04		54	

<< TEL NO. LIST >>

01	T222-2222
02	T123-4567
03	T800-447-4700
04	T[]
05	T333-3333

Secret Phone No.

Explanation of TEL LIST

- T...When you enter the telephone number with setting the DIALING MODE selector to the TONE position.
- R...When you enter the telephone number with setting the DIALING MODE selector to the PULSE position.

03 R526-3057

Printing a List of Stored Phone Numbers (TEL LIST)



Press **MENU** 4 times.

- The PROGRAM indicator will light.
- This display will appear.

PROGRAM [1. DATE 2. TEL
3. SYSTEM 4. REPORT]

Press "4".

SELECT NO. [1. SYSTEM
2. TEL NO. 3. JOURNAL]

Press "2".

- The unit will start printing.

PRINTING PHONE LIST

PRINTING REPORTS AND LISTS (CONT.)

Individual Transmission Report (XMT Report)

Each time a document is transmitted, this function will cause a record of the transmission to be printed. Once this function is set to ON, it will remain ON until it is switched OFF.

This function has been preset to OFF (Default).

Selection is as follows:

- OFFNO XMT report.
- ON.....Prints a report regardless of transmission failure.
- ERRORPrint a report when transmission failed.

```
***** XMT REPORT *****
*
*
* No.   OTHER FACSIMILE   START TIME   USAGE TIME   TX PAGES   RX PAGES   RESULT
*-----
* 01    092 481 7503      JAN. 1  7:38PM   00'58      01        00        OK
*
*
*
*
*
*
*
*
*
*
*****
```

Setting XMT Report

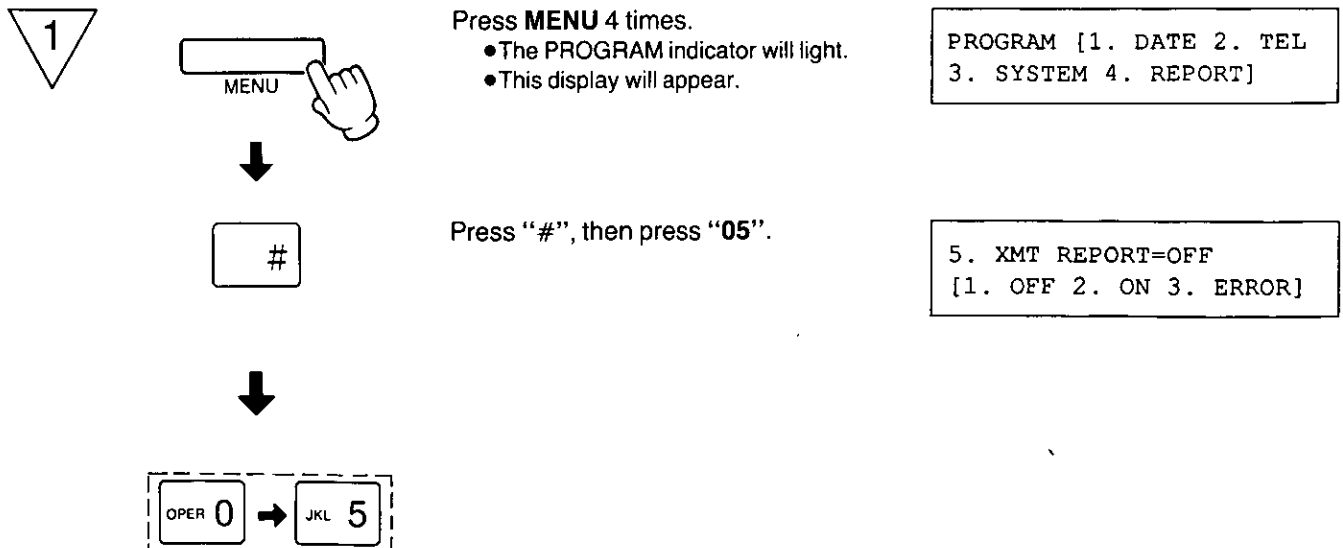

2

■ To turn on XMT report

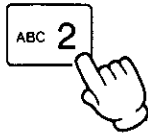

Press the buttons as follows.

Press "2".

- The report will always be printed to let you know if the transmission is successful or not.

5. XMT REPORT=ON
[1. OFF 2. ON 3. ERROR]

■ To turn on XMT (ERROR) report



Press "3".

- The report will be printed only when the transmission is not successful.

5. XMT REPORT=ERROR
[1. OFF 2. ON 3. ERROR]

■ To turn off XMT report

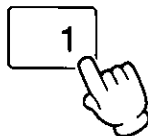

Press "1".

- The report will not be printed.

5. XMT REPORT=OFF
[1. OFF 2. ON 3. ERROR]

3

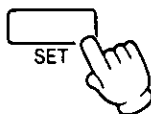

Press **SET** to store your selection.

PROGRAM [1. DATE 2. TEL
3. SYSTEM 4. REPORT]

4

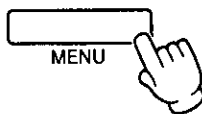

Press **MENU** to end the operation.

THU JUN 29 3:00PM 00

MAKING COPIES

Making Copies

The unit may also be used to make copies. Any documents which can be transmitted can be copied. The unit will automatically select FINE resolution. If you have selected SUPER FINE resolution, the unit will make copies with SUPER FINE resolution.

1

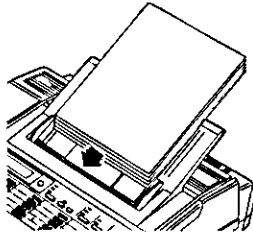

Insert the a document **FACE DOWN**.

THU JUN 29 3:00PM 00

2

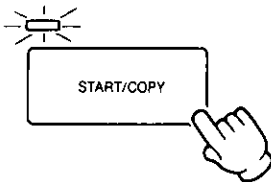

Press **START/COPY**.

THU JUN 29 3:00PM 00
COPYING DOCUMENT

Interrupting Copies



Press **STOP**.
●A document will be ejected.

THU JUN 29 3:00PM 00
USER STOPPED

How to Operate as an Answering Machine

QUICK REFERENCE CARD

FOR TONE REMOTE CONTROL

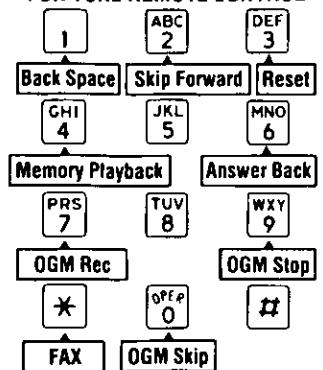

- To set Auto Receiving mode, call your unit and wait for 15 rings. The unit will answer, then hang up.
- To send the document, press *****, and FAX ID (if REMOTE FAX ID is set to ON.). Then start transmission.

PREPARING THE ANSWERING MACHINE

In this section, we are going to describe the preparation of the answering machine.

- Recording an Outgoing Message (OGM)
- Setting Up for Receiving Voice-Messages and a Document (Using as an Answering Machine and a Facsimile)
- Programming an ATAS ID Number for Remote Operation
- Programming a Callers' Recording Time

Recording an Outgoing Message (OGM)

To use the unit as both an answering machine and a facsimile, you should first record your Outgoing Message.

1

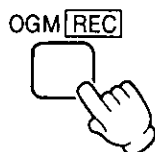

Press **OGM REC** until a long beep is heard, then release it.

- The IN USE indicator will light.

```
THU JUN29  3:00PM 00
OGM REC      >>>>>>>>
```

2

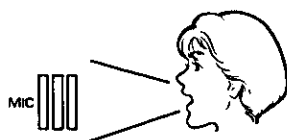

After the beep, speak immediately, clearly and loudly into the microphone, approximately 8 inches away.

- Recording time is 16 seconds.
- For optimum performance, record the OGM within 12 seconds.
- Do not pause for over 2 seconds while recording.

```
THU JUN29  3:00PM 00
OGM REC      ■■■■ >>>>>
```

3



When recording is finished, press **OGM REC** again.

- The unit will play back the OGM to confirm your message. Adjust the VOLUME control to an audible level.
- Verifying your OGM, press OGM PLAY. The OGM will be played from the microchip.

```
THU JUN29  3:00PM 00
OGM PLAY    >>>>>>>>
```

```
THU JUN29  3:00PM 00
TAPE BACK UP
```

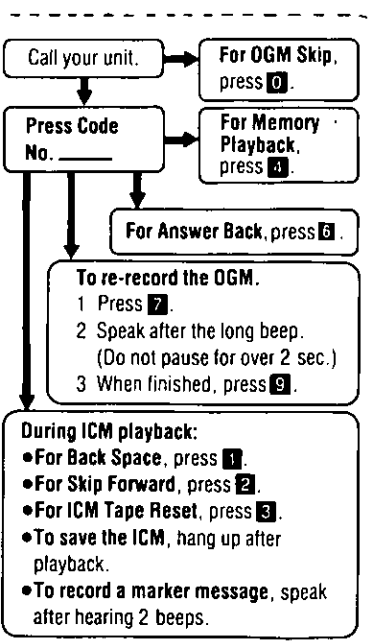

Samples of OGM

"This is Panasonic Company. To send a FAX, press the asterisk (*) button. To leave a message, speak after the long beep."

"This is Panasonic Company. To send a FAX, press the asterisk (*) button. To leave a message, speak up to 1 minute after the long beep."

OGM Backup

After recording your OGM on the microchip, it will be recorded onto the tape from the microchip as a backup.

If a power failure takes place or the POWER switch is set to OFF, the OGM recorded on the microchip will be erased. 7 seconds after the power is restored, the unit will automatically re-record the OGM onto the microchip using the OGM recorded on the tape.

•When you press a button, press firmly.

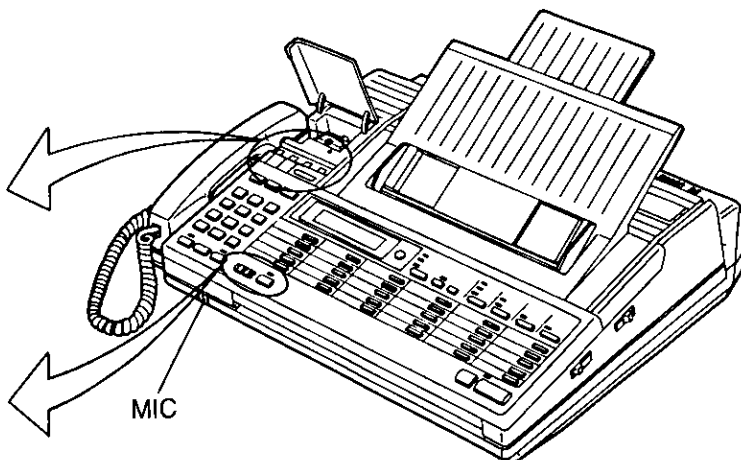
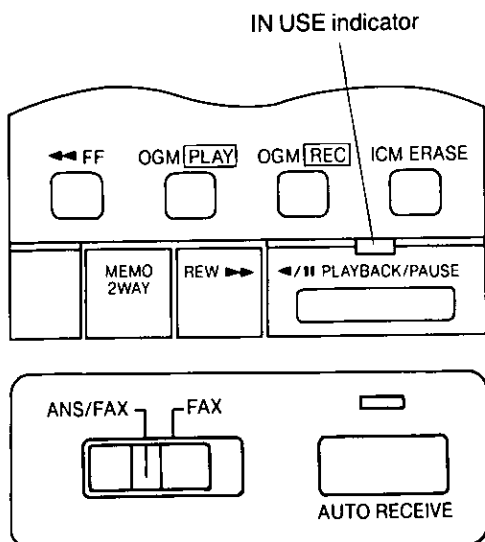

Setting Up for Receiving Voice-Messages and a Document (Using as an Answering Machine and a Facsimile)

1

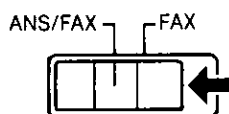

Set the FUNCTION selector to the **ANS/FAX** position.

- **ANS/FAX position:**
The unit switches between an answering and a facsimile functions automatically.

2

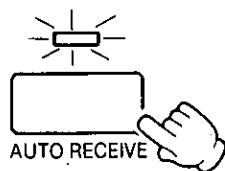

Press **AUTO RECEIVE**.

- The AUTO RECEIVE indicator will light.

3

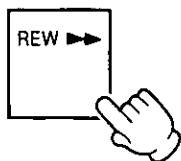

Press **REW** to record future messages from the beginning of the tape.

- When a call is received, the unit will begin playing back your OGM. Then the unit will automatically function as an answering machine or a facsimile depending on the caller's choice.
- If the caller's voice is not heard or the caller press the * button, the unit will automatically enter facsimile mode.

Voice Time/Day Stamp

When the messages are received, a voice synthesized announcement of the time and day will be recorded on the tape after the recorded message.

PREPARING THE ANSWERING MACHINE (CONT.)

Programming an ATAS ID for Remote Operation

An ATAS ID helps to protect you from unauthorized persons accessing your unit and retrieving your messages. The **ATAS ID number has been preset to 111 at the factory**. However, you may choose another ATAS ID from within the following ranges:

Single digit	1 to 9	} Refer to NOTE below.
Double digit	11 to 99	
Triple digit	111 to 999	

•To ensure proper operation, we recommend you use a different ATAS ID number from a FAX remote ID number.

Be sure the **SP-PHONE** indicator is off while programming.

Example:
ATAS ID is 123.

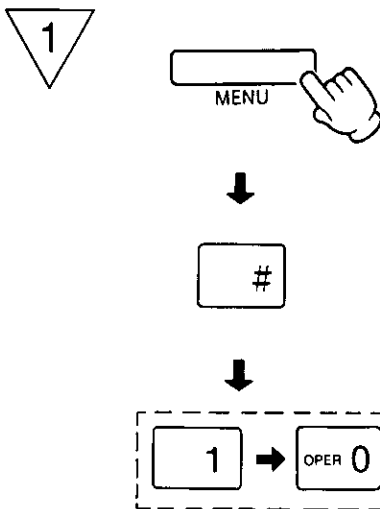

Press **MENU** 4 times.

- The PROGRAM indicator will light.
- This display will appear.

PROGRAM [1. DATE 2. TEL
3. SYSTEM 4. REPORT]

Press “#”, then press “10”.

10. ENTER YOUR REMOTE
ATAS ID=111

2 **Example:**
ATAS ID is 123.

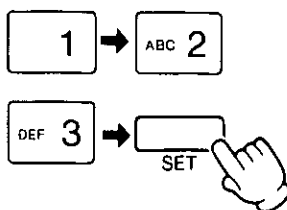

Enter the desired **ATAS ID**, then press **SET** to store your selection.

10. ENTER YOUR REMOTE
ATAS ID=123

PROGRAM [1. DATE 2. TEL
3. SYSTEM 4. REPORT]

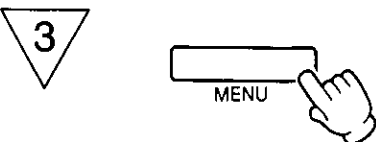

Press **MENU** to end the operation.

THU JUN 29 3:00PM 00

NOTE:

You cannot use codes which contain zero (0) as this will cause the unit to skip the OGM. We recommend that you do not use seven (7) as a code number, since this number is used as the OGM re-recording command for remote operations.

Programming a Caller's Recording Time

The recording time for Incoming Messages can be set to "VOX" or "1 MIN".
The callers' recording time is preset to "VOX".

Be sure the SP-PHONE indicator is off while programming.

1

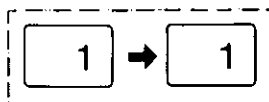

Press **MENU** 4 times.

- The PROGRAM indicator will light.
- This display will appear.

PROGRAM [1. DATE 2. TEL
3. SYSTEM 4. REPORT]

Press "#", then press "11".

11. RECORD TIME=VOX
[1. VOX 2. 1 MIN]

2

Enter your selection as follows.

■ Setting to "VOX"

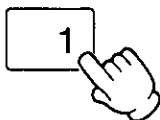

Press "1".

- The unit will record for as long as caller speaks.

11. RECORD TIME=VOX
[1. VOX 2. 1 MIN]

■ Setting to "1 MIN"

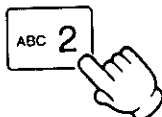

Press "2".

- The unit will record up to 1 minute.

11. RECORD TIME=1 MIN
[1. VOX 2. 1 MIN]

3

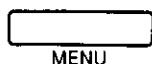
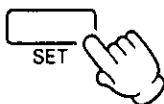

Press **SET** to store your selection.

PROGRAM [1. DATE 2. TEL
3. SYSTEM 4. REPORT]

Press **MENU** to end the operation.

THU JUN 29 3:00PM 00

OPERATING THE ANSWERING MACHINE

Fast Forwarding Tape

Press **FF**.

- The display will show;

```
THU JUN 29  3:00PM 03
ICM FORWARD  <<<<<<
```

Recording a Message Memo (Page 2-7)

Recording a 2-Way Conversation (Page 2-8)

Resetting (Rewinding) Tape

Press **REW**.

- The display will show;

```
THU JUN 29  3:00PM 03
ICM REWIND  >>>>>>
```

- The unit will rewind the tape, and future messages will be recorded over the old messages.

Call Counter

The unit will show you the number of recorded voice-messages by indicating them on the display and the AUTO RECEIVE indicator flashes.

```
THU JUN 29  3:00PM 03
```

The number of recorded voice-messages

- In case of power interruption, the Call Counter will show "--".

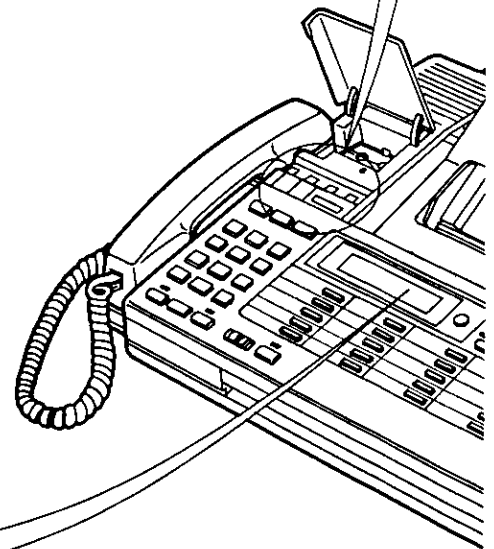
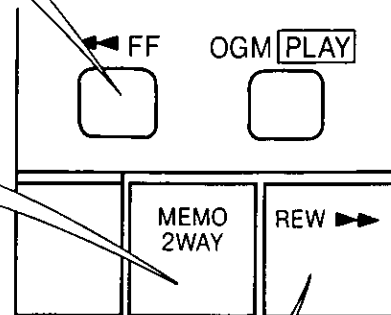

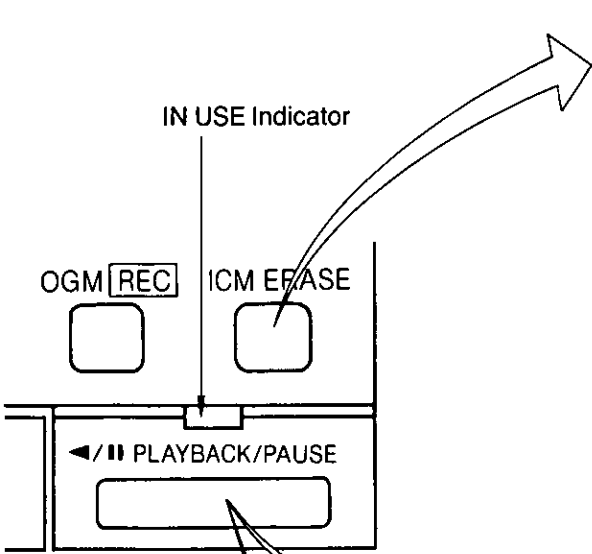

Erasing Recorded Messages

After reviewing your messages, you can erase them.

Press **ICM ERASE**.

- The display will show;

```
THU JUN 29  3:00PM 00
ICM ERASE      >>>>>>
```

- The messages will be erased while the tape is rewinding.
- The tape can be erased at high speed even if the recorded-prevention (knock-out) tabs have been removed.



Playing Back Recorded Voice-Messages

Press **PLAYBACK/PAUSE**.

- The display will show;

```
THU JUN 29  3:00PM 03
ICM PLAYBACK  <<<<<<
```

■ AUTO-LOGIC (One Touch Operation):

At the touch of the **PLAYBACK/PAUSE** button, the unit will play all the messages. At the end of the last message, the tape will stop, then 3 beeps will be heard. After 7 seconds, the unit will reset itself to the Auto Receiving mode.

All calls will be saved automatically.

- When the messages are received, a voice synthesized announcement of the time and day will be recorded on the tape after the recorded message.

Stopping Tape (Pause mode)

Press **PLAYBACK/PAUSE**.

- The display will show;

```
THU JUN 29  3:00PM 03
PAUSE
```

- The tape will pause until you restart it by pressing the **PAUSE** button again.
- The unit does not answer calls automatically while in pause mode.

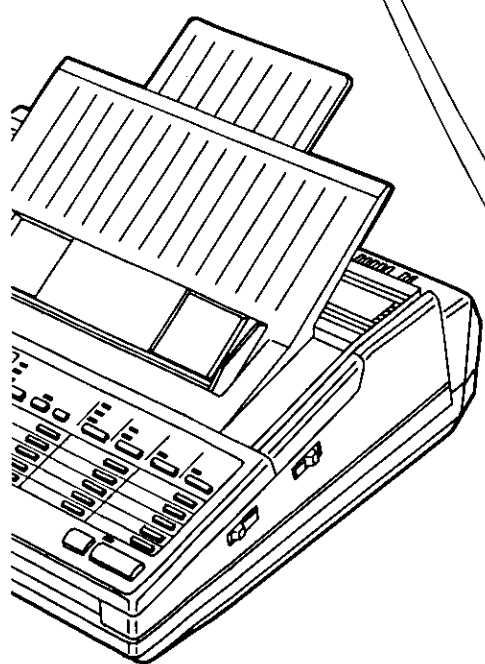

OPERATING THE ANSWERING MACHINE (CONT.)

Recording a Message Memo

You may record a message memo on the tape. It will be recorded as if it were an incoming call and **will be played back** if the unit is interrogated remotely or when the **PLAYBACK/PAUSE** button is pressed.

1

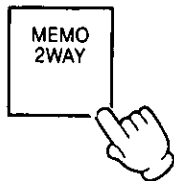

Press **MEMO/2 WAY** until a beep is heard.
•The IN USE indicator will light.

```
THU JUN 29  3:00PM 00
MEMO                <<<<<<
```

2

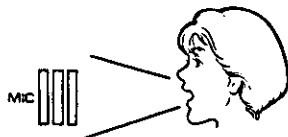

Speak into the microphone, approximately 8 inches away.
•Be sure that the volume control is properly set.

```
THU JUN 29  3:00PM 00
MEMO                <<<<<<
```

3

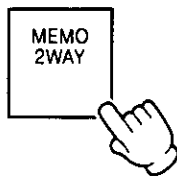

When recording is finished, press **MEMO/2 WAY** again.
•The IN USE indicator will go out.

```
THU JUN 29  3:00PM 01
```

Recording a 2-Way Conversation (2-Way Recording)

While speaking with someone on the telephone, you can record the conversation.

Many states have imposed regulations on the manner in which 2-Way telephone conversations may be recorded. Consult your local public utility agency (your telephone company).

1

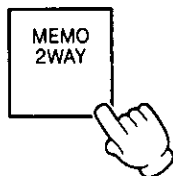

While having a conversation, press **MEMO/2 WAY** until a beep is heard.
•The IN USE indicator will light.

THU JUN 29 3:00PM 00
2WAY RECORDING

2



Talk with the other party.
•The unit will generate a beep every 15 seconds to notify the caller that the conversation is being recorded.

THU JUN 29 3:00PM 00
2WAY RECORDING

3

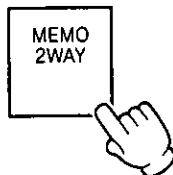

When recording is finished, press **MEMO/2 WAY** again.
•The IN USE indicator will go out.

THU JUN 29 3:00PM 01

OPERATING THE ANSWERING MACHINE (CONT.)

Saving Recorded Messages

You can save the desired messages.

1

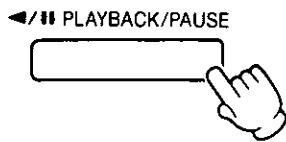

Play back the tape through the message you want to save, and press **PLAYBACK/PAUSE** to pause.

- The IN USE indicator will flash.

THU JUN 29 3:00PM 00
PAUSE

2

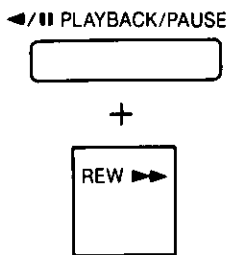

Press **PLAYBACK/PAUSE** and **REW** simultaneously.

- The IN USE indicator will go out.
- Future messages will be recorded after the messages you have saved.

THU JUN 29 3:00PM 00

Monitoring Incoming Calls

While an incoming message is being recorded, you can monitor it through the built-in speaker. Adjust the sound level using the VOLUME control. Then you choose to lift the handset and speak to the caller directly.



If you want to talk to the caller, **lift the handset** or press **SP-PHONE** and talk.

- The unit will stop recording automatically.

THU JUN 29 3:00PM 00
ATAS ANSWERING

HOW TO OPERATE FROM A REMOTE PHONE

On the following pages, we will explain the following features:

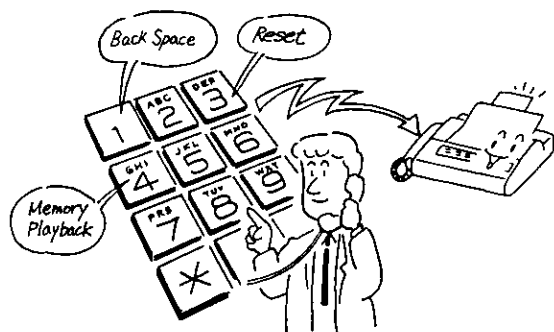

- Playing Back Messages
- Playing Back Newly-Recorded Messages (Memory Playback)
- Back Space and Skip Forward
- Resetting Tape for Future Messages
- Recording a Marker Message
- Turning On the Speakerphone (Answer Back)
- Re-Recording the Outgoing Message
- Skipping the OGM for ICM Recording
- Turning On the Auto Receiving Mode

You can retrieve the recorded incoming messages from a remote location with a tone telephone.

Summary of Remote Control Functions

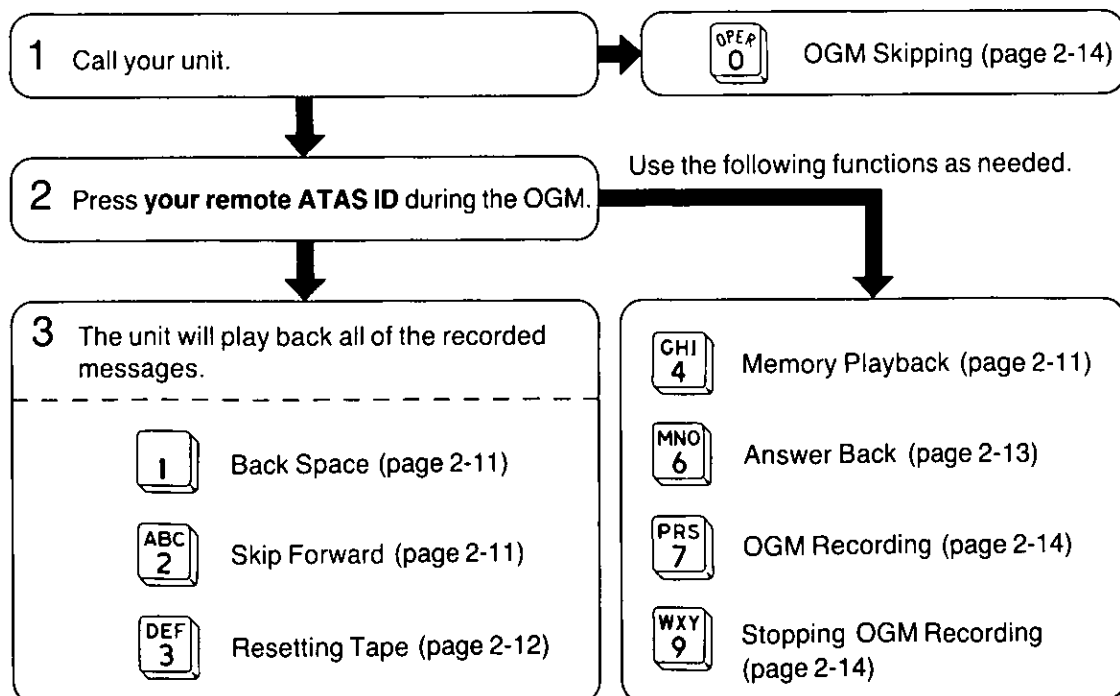

HOW TO OPERATE FROM A REMOTE PHONE (CONT.)

Playing Back Messages

You can listen to the recorded messages by simply pressing your ATAS ID. (Refer to page 2-3.)

1



Call your unit, then press **your remote ATAS ID** during the OGM.

- A beep will sound, then other beeps will sound to tell you the number of recorded messages up to 8 times.
- You will hear all the messages.

2



Listen to the messages.

- 3 beeps will be heard after the last message is played back.

3



Hang up.

- All calls will be saved automatically.

Playing Back Newly-Recorded Messages (Memory Playback)

When you have already heard the messages from a remote phone, you can skip them and only listen to the newly-recorded ones.

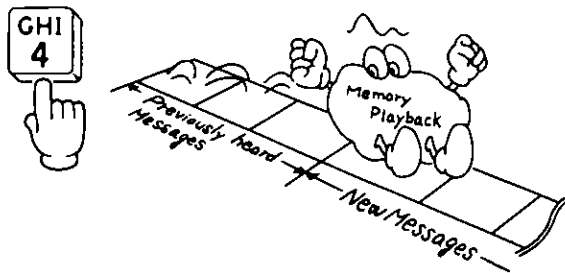

After entering your remote ATAS ID during the OGM, press "4" right after hearing the beep tones indicating the number of recorded messages.

- The unit will playback the new messages.

Even during the playback of previously heard messages, you can skip them by pressing "4".

Back Space and Skip Forward



Back Space

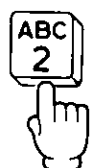

Skip Forward

Press "1" to rewind (back space) the tape.

Press "2" to fast forward (Skip Forward) the tape.

- The tape will be rewound or skipped for approximately 15 seconds corresponding to the playback time.

Resetting Tape for Future Messages

After retrieving the messages, you can reset the tape and record future messages from the beginning of the tape.

After all the messages have been played back or while they are playing



Press "3", then hang up.

- The unit will rewind the tape and reset itself.

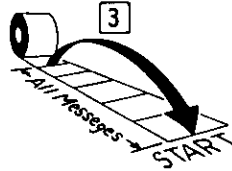

If you have used the Memory Playback



Press "3".

- The unit will rewind the tape to the beginning of the newly-recorded messages and a beep will be heard.



Press "3" again after hearing a beep.

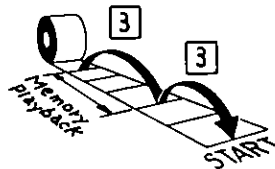

If you have reset the tape by mistake



Press "2" after the tape has been reset (one beep).

- The unit will advance the tape to the end of the recorded messages.

HOW TO OPERATE FROM A REMOTE PHONE (CONT.)

Recording a Marker Message

After retrieving all of your messages from a remote phone, you can leave a message to anyone who knows your ATAS ID without redialing.

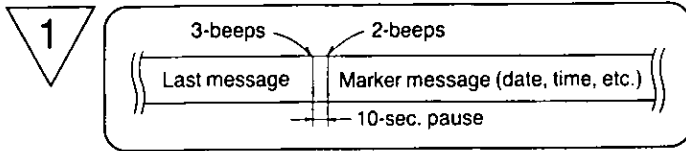

3 beeps will be heard after the last message, followed by a 10-second pause, and then 2 beeps will be heard.



Speak immediately after the last 2 beeps.



When recording is finished, hang up.

- The marker message will be recorded after the last message on the tape.

Turning On the Speakerphone (Answer Back)

You may monitor sounds in the room where the unit is installed by turning on the speakerphone remotely. You can also speak with anyone in the room, even if they cannot reach the unit.



Press "6".

- The speakerphone of your unit will be turned on and you can monitor the room sound for 30 seconds.
- To monitor further, press "6" again within 10 seconds of hearing one beep.

If you want to talk to the other party in the room



Ask the other party to press the SP-PHONE button, and then start the conversation.

- If no one answers, the line will terminate after 30 seconds.
- To use this function, position the SPEAKER VOLUME control for normal use, otherwise it may be difficult for anyone to hear you from the speaker.

Re-Recording the Outgoing Message

You can record a new Outgoing Message from a remote phone.

1



Press "7" to start recording.

2

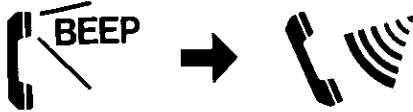

After hearing a long beep, **speak clearly and loudly for up to 16 seconds.**

3



When recording is finished, press "9".

- The new Outgoing Message will be played back. So you can check or amend it.

NOTE:

If you pause for over 2 seconds while recording, you will hear a series of warning tones (6 beeps). If this happens, repeat from step 1.

Skipping the OGM for ICM Recording

If you would like to leave a message on your unit, but do not want to listen to your OGM before doing so, you can switch directly to the Incoming Message (recording) mode.

1



Call your unit.

2

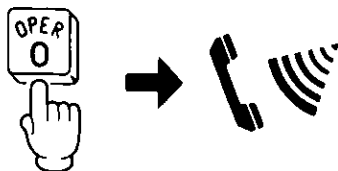

Press "0" during the OGM (instead of your ATAS ID).

- One beep will be heard and the unit will go directly to the recording mode.
- After hearing a long beep, speak clearly and loudly to leave your message.

HOW TO OPERATE FROM A REMOTE PHONE (CONT.)

Turning On the Auto Receiving Mode

You may turn the unit on from a remote phone using any telephone.

1

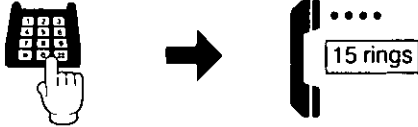

Call your unit, and **wait for 15 rings.**

- The unit will answer.

2



After hearing the OGM or the beep tones, then hang up.

- If the **FUNCTION** selector is set to the **ANS/FAX** position, the OGM will be heard.
- If the **FUNCTION** selector is set to the **FAX** position, you will hear several beeps (answering carrier tone).

NOTE:

If you hear 6 beep tones after your OGM, the tape is full. Reset the tape. Refer to the procedure of "Resetting Tape for Future Messages" on page 2-12.

How to Operate as a Telephone

MAKING AND RECEIVING A CALL

Making a call

1

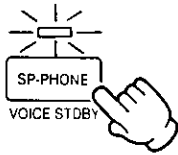

Lift the handset or press **SP-PHONE**.

THU JUN 29 3:00PM 00
ENTER PHONE NUMBER

2

Manual Dialing



Dial the phone number.

- The display will show the dialed number.

THU JUN 29 3:00PM 00
XXXXXXXX

dialed number

ONE-TOUCH dialing

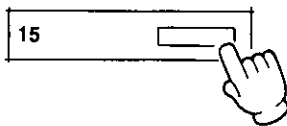

Press a **ONE-TOUCH** station.

- For programming the phone numbers, see page 1-35.

THU JUN 29 3:00PM 00
<XXXXX>

station number

SPEED dialing

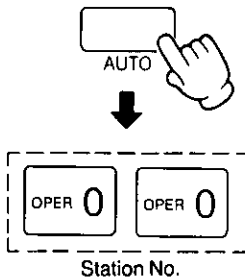

Press **AUTO**, then press a **SPEED DIALING** station (2 digits).

- For programming the phone numbers, see page 1-37.

THU JUN 29 3:00PM 00
<XXXXX>

station number

3



Speak with the other party.

- To terminate the call, hang up the handset or press the SP-PHONE button.

Receiving a Call

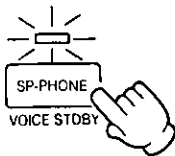

When the phone rings, lift the handset or press SP-PHONE to answer the call.

Redialing

You can redial the last dialed number using the REDIAL button.

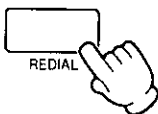

Press **REDIAL** if busy tone is heard.

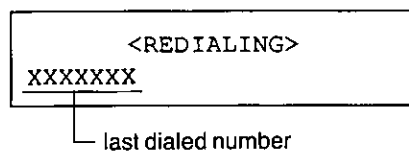

■ When using the handset:

Pressing the REDIAL button redials the last number once.

■ When using the Hands-Free Operation (SP-PHONE):

The unit will redial up to 15 times within a 10-minute period automatically.

During the pause between each redialing, the display will show the following message, and the SP-PHONE indicator will flash slowly.

THU JUN 29 3:00PM 00
WAITING TO REDIAL

To cancel automatic redialing, press the FLASH button.

SWITCHING TO HANDS-FREE OR HANDSET OPERATION DURING A CONVERSATION

You may choose to switch to the handset or the speakerphone during a conversation.

Handset to Hands-Free

1



Press **SP-PHONE** and **continue speaking**.

- The SP-PHONE indicator will light.

2

Replace the handset onto the cradle.

- If you replace the handset onto the cradle before pressing the SP-PHONE button, the conversation will be cut off.



Handset

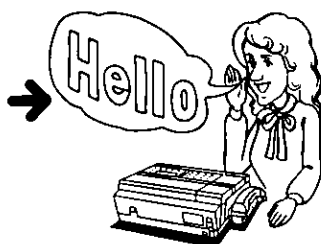

Hands-Free

Hands-Free to Handset

Lift the handset while speaking in a hands-free operation.

- The SP-PHONE indicator will go out.

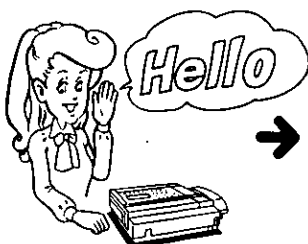

Hands-Free



Handset

OTHER FEATURES

Mute Operation

Use this feature when you do not want your voice to be heard by the other party.

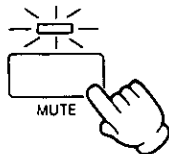

Press **MUTE**.

- The MUTE indicator will light.
- To resume the conversation; press the MUTE button again. The MUTE indicator will go out.

Flash Button (Accessing to PBX)

You can access some of the features of your host PBX by using the FLASH button.

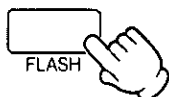

Press **FLASH** briefly when required.

- "FLASH" can also be stored into memory the same as "PROGRAMMING AUTOMATIC DIALING NUMBERS" on page 1-35 to 1-40.

Tone Button Dialing

If your telephone line is pulse (rotary phone) and you wish to change from PULSE to TONE while dialing;

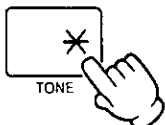

Press "*****" (Asterisk).

- When you hang up, the unit will automatically return to the pulse mode.
- Pressing the TONE button counts as 1 digit while programming.

Combination Dialing

Any of the following dialing combinations is possible using the speakerphone or the handset.

- Automatic and manual dialing
- Pulse and tone dialing
- Plural memory stations

OTHER FEATURES (CONT.)

Outside Line or Computer Accessed Line (Pause Button)

Using the PAUSE function during a dial operation is helpful when accessing an outside or a computer accessed long distance service.

One pause is required when waiting for an outside dial tone. (Behind PBX)

Example:



Line access number.

- Some PBXs require this pause during automatic redialing.

Two pauses are required when waiting for a computer tone from long distance service companies such as MCI, SPRINT, METRO and others.

Example:

Local access telephone number for the alternate long distance service company:

123-4567

Authorization number:

4321

Long distance number:

987-654-3210

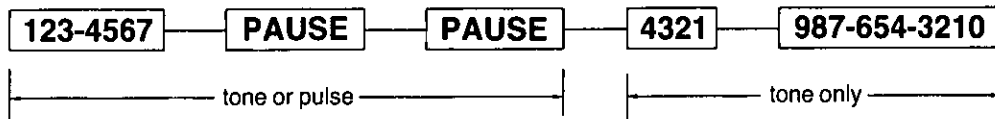

- The above numbers are used as examples only.
- Pressing the PAUSE button once counts as 1 digit.
- A maximum of 30 digits may be used.

General Informations

TROUBLESHOOTING GUIDE

LC DISPLAY

CAUSE & REMEDY

THU JUN 15 3:00PM 00
*** CHECK COVER ****

The paper cover is open, close it.

THU JUN 15 3:00PM 00
** CHECK DOCUMENT **

Document is not properly fed. Re-insert the document again.

THU JUN 15 3:00PM 00
CHECK ICM TAPE

- Tape is broken or is not installed. Install a new one. (When replace the tape, record your OGM.)
- Tape is full. Reset it or use 2-side of the tape.

THU JUN 15 3:00PM 00
*** CHECK MEMORY ***

The memory (phone numbers, parameters etc.) is erased. Reprogram them.

THU JUN 15 3:00PM 00
**** RECORD OGM ****

OGM is not recorded. Record your OGM.

THU JUN 15 3:00PM 00
*** OUT OF PAPER ***

The recording paper roll is empty or recording paper is (almost) finished, replace it.

THU JUN 15 3:00PM 00
*** PAPER JAMMED ***

- The recording paper is jammed, re-install it.
- Make sure that the recording paper has no slack.

THU JUN 15 3:00PM 00
** POLLING ERROR **

- Polling password does not match. Set the same password as the other unit has.
- The polled unit is not being programmed for polled setting.
- Polling function may be performed between KX-F220's which have the same protocol if polling password is set.

* UNIT OVERHEATED, *
PLEASE WAIT

The unit may overheat. Leave the unit as it is and allow the unit to cool.

LC DISPLAY

CAUSE & REMEDY

THU JUN 15 3:00PM 00
* REMOVE DOCUMENT **

- Document has jammed. Open the paper cover and remove it.
- When you transmit a document which is longer than 600 mm, press the STOP button to remove it.

THU JUN 15 3:00PM 00
***** TX ERROR *****

Transmission error occurred. Try again.

- If the recording paper is jammed, open the cover (arrow A) and remove it.

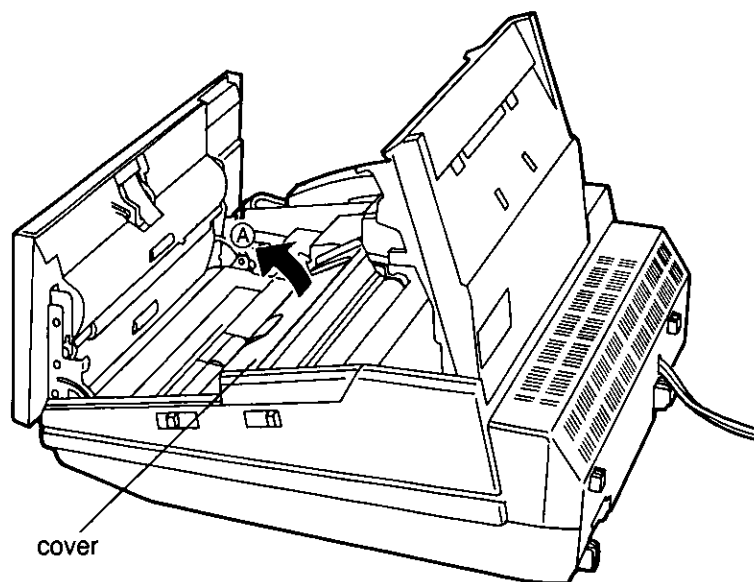

TROUBLESHOOTING GUIDE (CONT.)

FACSIMILE

PROBLEM	CAUSE & REMEDY
■ I cannot receive documents automatically.	<ul style="list-style-type: none">● Make sure that a recording paper is installed.● Make sure the unit is set to the Auto Receiving mode.● Shorten your OGM and ask the other party to press “*” (ASTERISK) to transmit a document.
■ Recording image is scratchy and cannot be read completely.	The sender transmitted a light density document. Have the other sender darken the document (e.g. by copying) then have them transmit it again.
■ The other party complains that documents are being received with distorted letters.	<ul style="list-style-type: none">● If you have call waiting service, it may have been activated by another telephone call. Re-connect the unit to a line that does not have call waiting service.● Someone may have used a telephone connected in parallel with the unit. Avoid connecting the same line for the unit and other telephones.
■ The START/COPY indicator flashes for about 40 seconds after the unit receives a call automatically, but nothing is recorded.	The caller hung up during or immediately after the playback of the OGM. This may occur if the disconnect signal is not transmitted from the Central Office, and your unit is in normal condition.
■ When I receive or copy a document whose background is very dark or containing photographs, the unit may produce a high tone.	This is quiet normal.
■ I cannot send a document to my KX-F220 even after I press “*”.	The remote Fax ID may be turned on. Enter your remote Fax ID after pressing “*”.
■ The unit does not operate properly.	Turn the POWER switch off, then turn it on again.
■ Problems of receiving international facsimiles.	<ul style="list-style-type: none">● Refer to page 4-14.● Shorten OGM to 10 seconds or less.● G III receiving speed may need to be set to 4800 bps.● CED frequency may need to be set to 1100 Hz.

ANSWERING MACHINE & TELEPHONE

PROBLEM	CAUSE & REMEDY
■ When the Call-Counter shows “--”.	<ul style="list-style-type: none">● A power failure has occurred, confirm whether the voice messages are recorded on the tape or not.● The ICM tape is not rewound after the unit is turned on.
■ The unit does not work when I press buttons.	Turn the POWER switch off, then turn it on again.
■ The unit has been set to the Auto Receiving mode, but no voice-messages have been recorded.	<ul style="list-style-type: none">● The tape is broken (cut, worn out or twisted) or not installed.● Change the FUNCTION selector to the ANS/FAX position.
■ When the tape is played back, the sound level is lower and nothing is heard.	<ul style="list-style-type: none">● Raise the sound level using the SPEAKER VOLUME control.● Clean the head. See “MAINTENANCE” on page 30 in INSTALLATION MANUAL.
■ I have played back all the recorded messages and I want to record the next call after the last message	Leave the unit as it is after hearing the messages.
■ I cannot retrieve recorded messages from a remote phone.	<ul style="list-style-type: none">● Make sure that you use your own ATAS ID number.● When you press your ATAS ID number, press firmly.
■ Some voice-messages have not been fully recorded.	Set the CPC to “B”.
■ When the caller hangs up after leaving message, the tape does not stop.	Vox detect time should be set to 4 seconds.
■ The unit does not ring.	Set the RINGER VOLUME selector to the HIGH or LOW position.
■ The caller suddenly cannot hear my voice during a conversation.	Look at the MUTE indicator. If it is lit, press the MUTE button to resume the conversation.

RECORDING PAPER INSTALLATION

Follow the steps below to install the recording paper.

- Replace the recording paper roll either the red end mark appears on the both sides of the paper, or the LC Display shows "OUT OF PAPER". (Note: The end mark will not appear on some recording paper rolls)
- The unit will stop receiving or copying when the LC Display shows:

MON DEC25 7:30PM 00
OUT OF PAPER

CAUTION: You should only use Panasonic recording paper (KX-A102) as the print quality may otherwise be reduced or excessive thermal head wear may occur.

1

Slide BACK LID Lever in the direction of the arrow to open the cover.

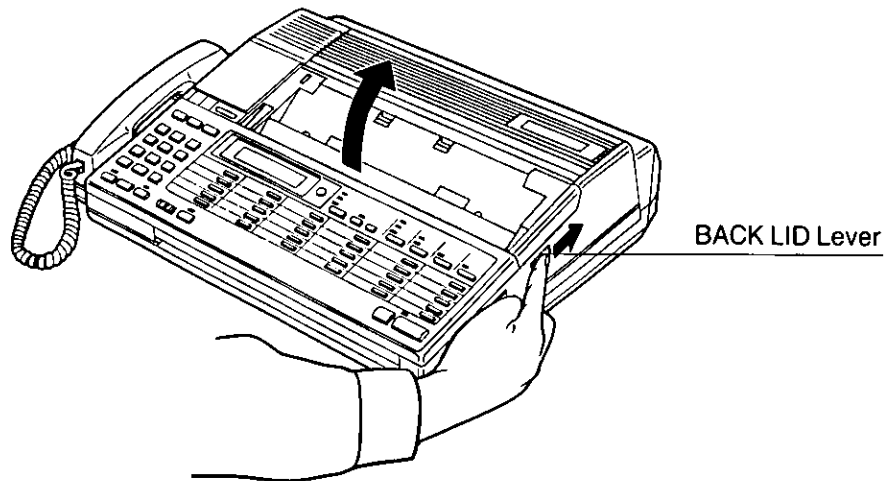

2

Insert a roll of recording paper into the paper compartment so that it may be tightly rolled, without any slack. (Make sure that the shiny side of the paper is facing up.)

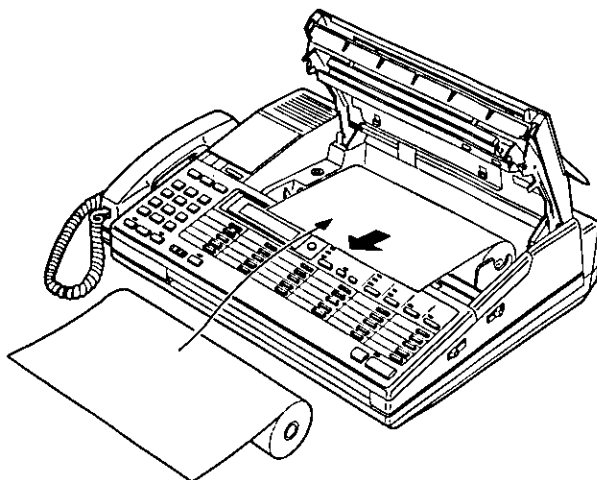

Caution:

- Make sure that a roll is correctly installed. If it is reversed, no message will be recorded.

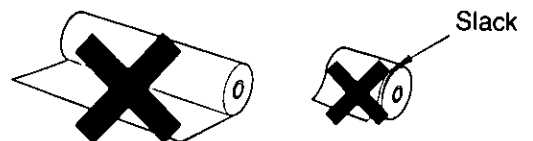

3

Insert the end of the recording paper between the upper and lower guide plates, about one or two inches, until the paper stops. See described below.
(Align the recording paper with the inside two guide marks.)

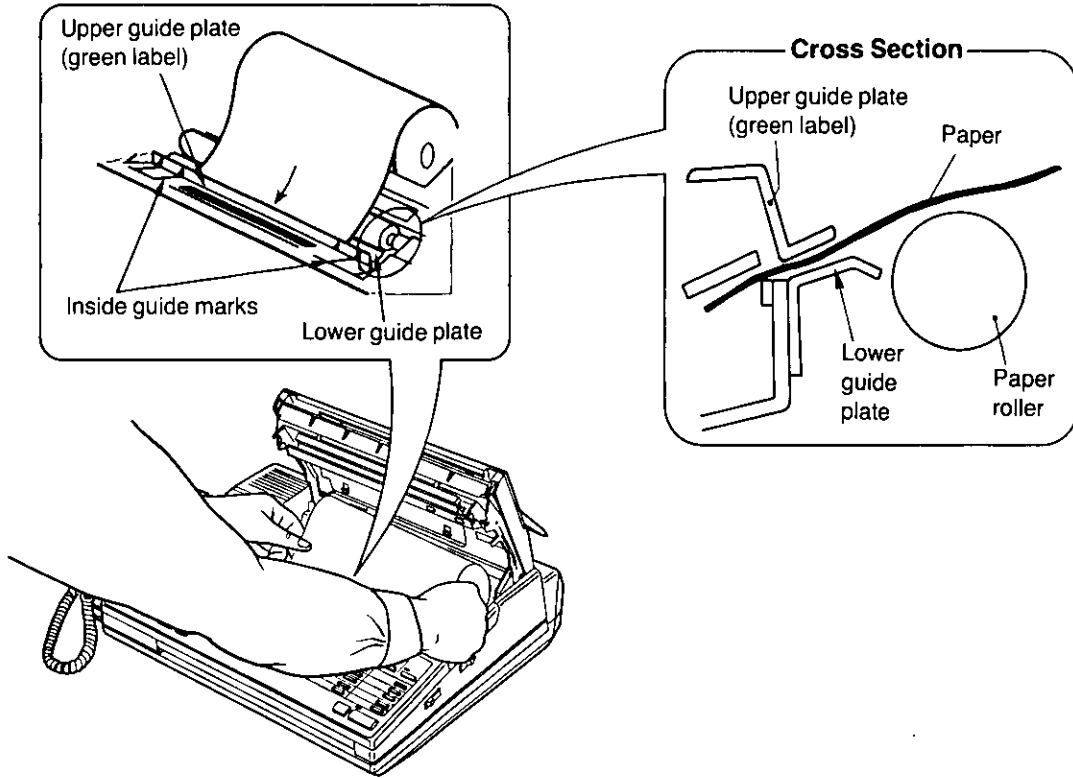

4

Close the cover carefully by pressing both ends gently.

- The recording paper will be projected slightly and be cut automatically.

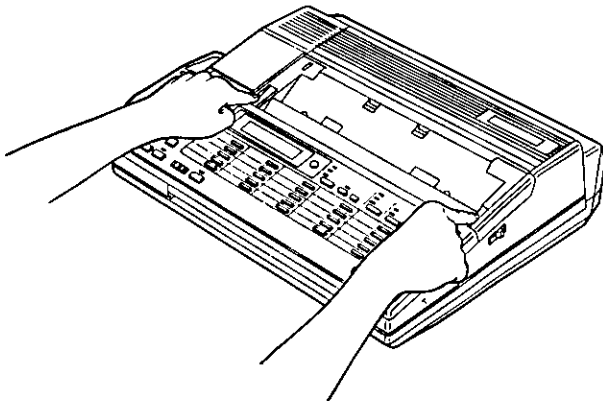

Caution:

- If the LC Display shows the message below when you close the cover, close it again carefully.

MON DEC25 7:30PM 00
CHECK COVER

DOCUMENT TRAY INSTALLATION

The Document tray and the stacker are installed as described below.

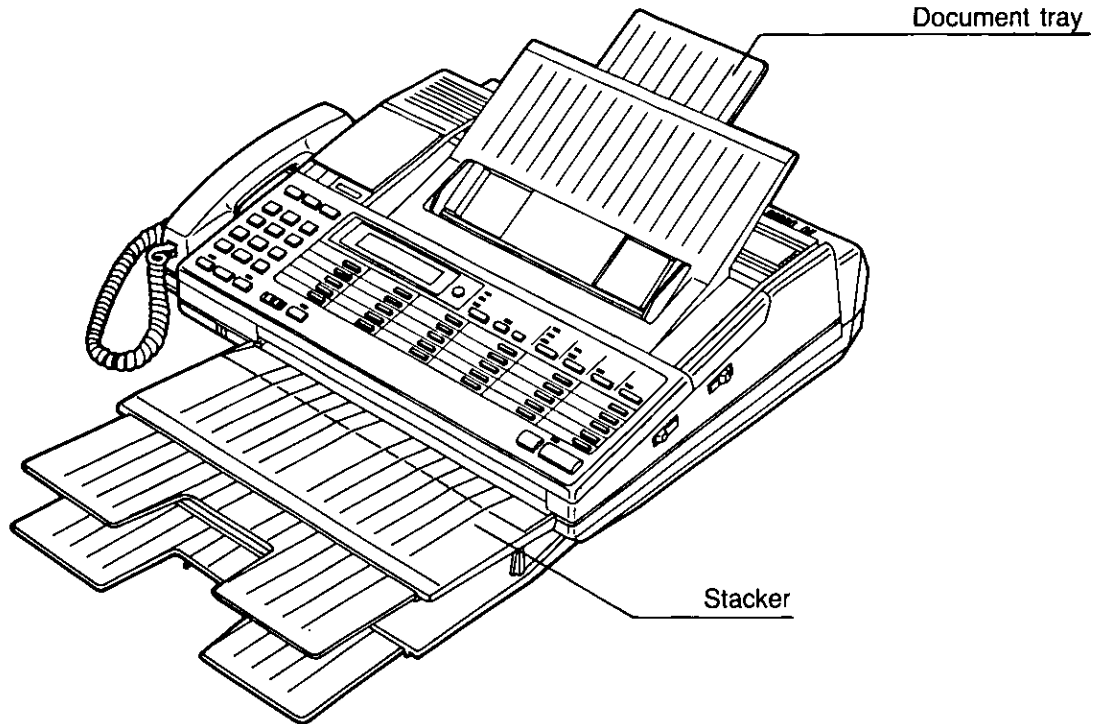

1

Position the Document tray to fit into the grooves of the unit (arrow A). Then press B with both hands.

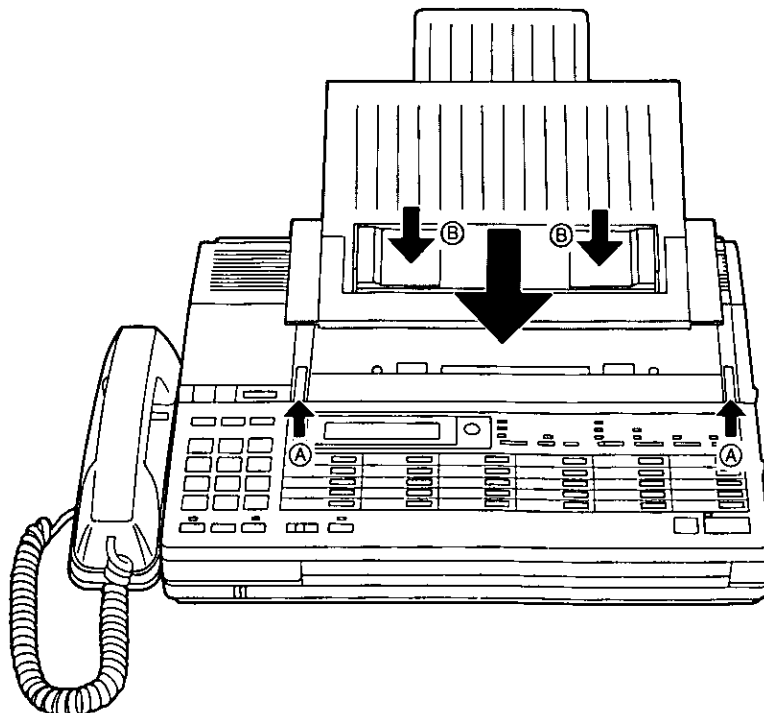

2

Connect the tabs of the Lower stacker to the holes of the Upper stacker.

- ① Connect a tab to a hole.
- ② Tilt the Upper stacker until it stops by lifting the edge of the Upper stacker.
- ③ Connect the other tab to the other hole.

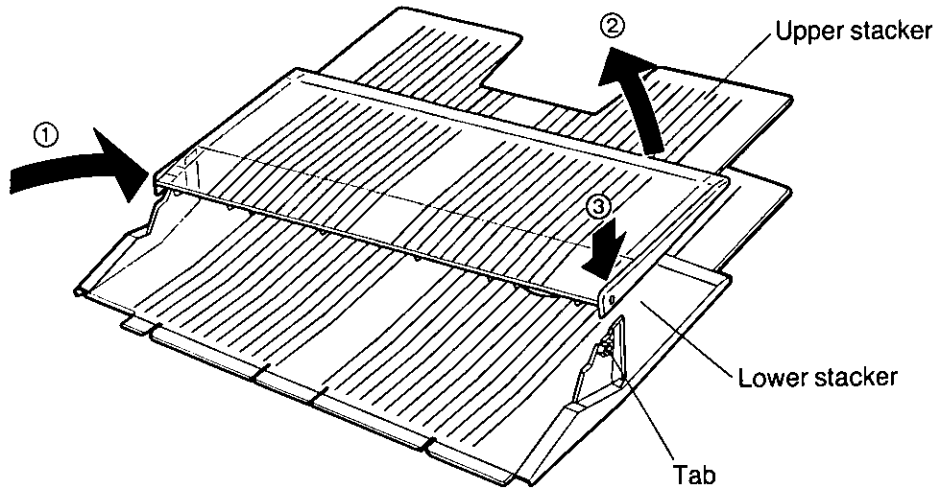

3

How to install the Stacker

Insert the stacker along the stacker guide of the unit until the Upper stacker reaches to the front side of the unit.

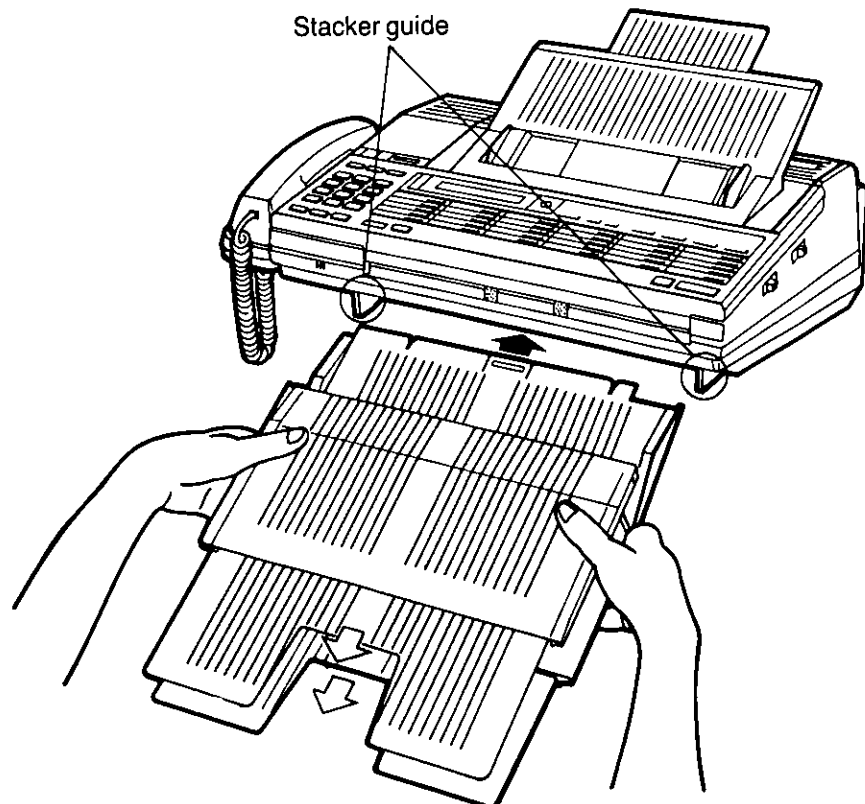

SYSTEM PROGRAMMING FUNCTIONS

CPC MODE

The CPC (Calling Party Control) mode selection;

A: Usual selection (Default)

B: Select "B" in case of the followings.

When you use the call waiting service.

When some of incoming messages on the answering machine are interrupted.

NOTE:

When you use the call waiting service and the CPC mode is set to "A", the call waiting service does not function.

■ Changing parameter

1

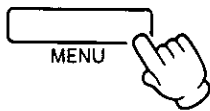

Press **MENU** 4 times.

- The PROGRAM indicator will light.
- This display will appear.

```
PROGRAM[1.DATA 2.TEL  
3.SYSTEM 4.REPORT]
```

2

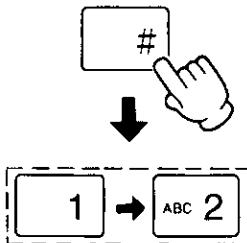

Press "#", then press "12".

```
12.CPC MODE=A  
[1.A 2.B]
```

3

Example: Changing to "B".

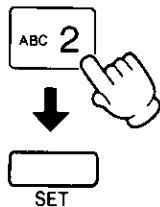

Press "2", then press **SET**.

```
12.CPC MODE=B  
[1.A 2.B]
```

```
PROGRAM [1.DATA 2.TEL  
3.SYSTEM 4.REPORT]
```

4



Press **MENU** to end the operation.

```
THU JUN29 3:00PM 00
```

AUX. LEADS

The AUX. LEADS setting;

OUT: Usual selection (Default)

IN: Some KSUs (Key Service Unit) may require you to set the AUX. LEADS to "IN". Follow the instruction manual of your host PBX. You can use as many function of your host PBX as you like.

NOTE:

If you do not need to use AUX. LEADS, set to "OUT" always.

■ Changing parameter

1



Press **MENU** 4 times.

- The PROGRAM indicator will light.
- This display will appear.

```
PROGRAM[1.DATA 2.TEL
3.SYSTEM 4.REPORT]
```

2

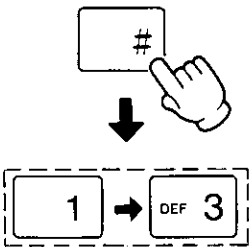

Press "#", then press "13".

```
13.AUX.LEADS=OUT
[1.OUT 2.IN]
```

3 **Example: Changing to "IN".**

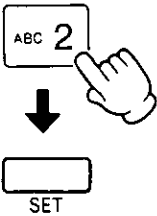

Press "2", then press **SET**.

```
13.AUX.LEADS=IN
[1.OUT 2.IN]
```

```
PROGRAM[1.DATA 2.TEL
3.SYSTEM 4.REPORT]
```

4



Press **MENU** to end the operation.

```
THU JUN29 3:00PM 00
```

SYSTEM PROGRAMMING FUNCTIONS (CONT.)

DIAL PULSE

The DIAL PULSE SPEED setting;

This option is for pulse line.

10 PPS: This pulse speed is 10 pulse per second (Default).

20 PPS: This pulse speed is 20 pulse per second. If your telephone line is "20 PPS", select "20 PPS" for your fast dialing.

NOTE:

When your telephone line is tone, this is not necessary.

■ Changing parameter

1

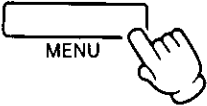

Press **MENU** 4 times.

- The PROGRAM indicator will light.
- This display will appear.

```
PROGRAM[1.DATA 2.TEL
3.SYSTEM 4.REPORT]
```

2

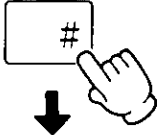

Press "#", then press "14".

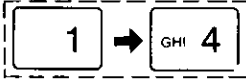

```
1 → GHI 4
```

```
14.DIAL PULSE=10PPS
[1.10PPS 2.20PPS]
```

3 Example: Changing to "20 PPS".

Press "2", then press **SET**.

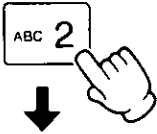

```
14.DIAL PULSE=20PPS
[1.10PPS 2.20PPS]
```

```
PROGRAM[1.DATA 2.TEL
3.SYSTEM 4.REPORT]
```

4



Press **MENU** to end the operation.

```
THU JUN29 3:00PM 00
```

PHONE TONE DETECT

The PHONE TONE DETECT setting;

This unit is automatically disconnected when detecting a busy tone after dialing in SP-PHONE mode.

OFF: The unit does not detect a busy tone (Default).

ON: The unit detects a busy tone.

■ Changing parameter

1

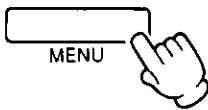

Press **MENU** 4 times.

- The PROGRAM indicator will light.
- This display will appear.

PROGRAM [1.DATA 2.TEL
3.SYSTEM 4.REPORT]

2

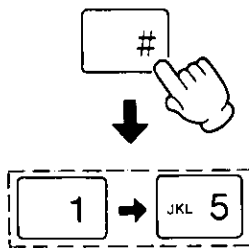

Press "#", then press "15".

15.TONE DETECT=OFF
[1.OFF 2.ON]

3

Example: Changing to "ON".

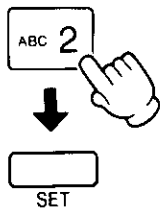

Press "2", then press **SET**.

15.TONE DETECT=ON
[1.OFF 2.ON]

PROGRAM [1.DATA 2.TEL
3.SYSTEM 4.REPORT]

4



Press **MENU** to end the operation.

THU JUN29 3:00PM 00

SYSTEM PROGRAMMING FUNCTIONS (CONT.)

TX SPEED

The TX (Transmission) SPEED setting;

The unit can automatically establish the optimum transmitting speed depending on the line condition and other facsimile machines transmission speed.

9600 BPS: The maximum speed is 9600 Bit Per Second (Default).

If you experience problems frequently (e.g. Transmitting error during transmission mode) caused by poor line condition, set to "4800 BPS".

4800 BPS: The maximum speed is 4800 Bit Per Second.

NOTE:

If the START indicator usually flashes for more than 20 seconds after pressing the START/COPY button, the unit will change to "4800 BPS" automatically.

■ Changing parameter

1



Press **MENU** 4 times.

- The PROGRAM indicator will light.
- This display will appear.

```
PROGRAM[1.DATA 2.TEL  
3.SYSTEM 4.REPORT]
```

2

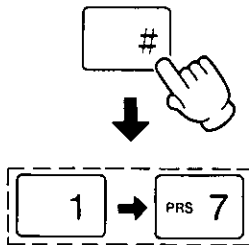

Press "#", then press "17".

```
17.TX SPEED=9600BPS  
[1.9600 2.4800]
```

3

Example: Changing to "4800 BPS".

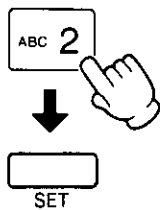

Press "2", then press **SET**.

```
17.TX SPEED=4800BPS  
[1.9600 2.4800]
```

```
PROGRAM[1.DATA 2.TEL  
3.SYSTEM 4.REPORT]
```

4



Press **MENU** to end the operation.

```
THU JUN29 3:00PM 00
```

RX SPEED

The RX (Receiving) SPEED setting;

The unit can automatically establish the optimum receiving speed depending on the line condition and other facsimile machines transmission speed.

9600 BPS: The maximum speed is 9600 Bit Per Second (Default).

If you experience problems frequently (e.g. The received document quality is wrong or Terminated telephone line during receiving mode.) caused by poor line condition, set to "4800 BPS".

4800 BPS: The maximum speed is 4800 Bit Per Second.

NOTE:

If 4800 BPS is set when you do not have the problems, receiving speed is slower than when 9600 BPS is set.

■ Changing parameter

1



Press **MENU** 4 times.

- The PROGRAM indicator will light.
- This display will appear.

PROGRAM[1.DATA 2.TEL
3.SYSTEM 4.REPORT]

2

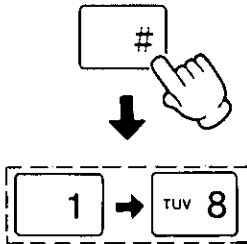

Press "#", then press "18".

18.RX SPEED=9600BPS
[1.9600 2.4800]

3

Example: Changing to "4800 BPS".

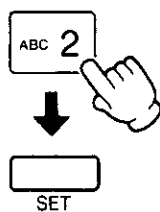

Press "2", then press **SET**.

18.RX SPEED=4800BPS
[1.9600 2.4800]

PROGRAM[1.DATA 2.TEL
3.SYSTEM 4.REPORT]

4



Press **MENU** to end the operation.

THU JUN29 3:00PM 00

SYSTEM PROGRAMMING FUNCTIONS (CONT.)

STAMP DEFAULT

The STAMP DEFAULT setting;

You can print the STAMP (⊗) on your originals when transmitting a document successfully.

ON: The STAMP indicator is lit. Press the STAMP button if you do not want to print the ⊗ mark. After the transmission, it will be ON automatically.

OFF: The STAMP indicator go out. Press the STAMP button if you want to print the ⊗ mark. After the transmission, it will be OFF automatically.

■ Changing parameter

1



Press **MENU** 4 times.

- The PROGRAM indicator will light.
- This display will appear.

```
PROGRAM[1.DATA 2.TEL  
3.SYSTEM 4.REPORT]
```

2

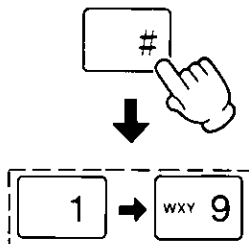

Press "#", then press "19".

```
19.STAMP DEFAULT=OFF  
[1.OFF 2.ON]
```

3

Example: Changing to "ON".

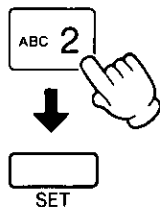

Press "2", then press **SET**.

```
19.STAMP DEFAULT=ON  
[1.OFF 2.ON]
```

```
PROGRAM[1.DATA 2.TEL  
3.SYSTEM 4.REPORT]
```

4



Press **MENU** to end the operation.

```
THU JUN29 3:00PM 00
```

AUTO STANDBY

The AUTO STANDBY setting;

RESOLUTION, DOCUMENT CONTRAST and HALF-TONE setting return to the following standby mode after each transmission.

RESOLUTION: FINE or SUPER FINE → STANDARD
 CONTRAST: DARKER → NORMAL
 HALF-TONE: ON (Indicator is lit.) → OFF (Indicator is off.)

ON: These functions are enable (Default).

OFF: These functions are disable.

■ Changing parameter

1

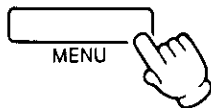

Press **MENU** 4 times.

- The PROGRAM indicator will light.
- This display will appear.

```
PROGRAM[1.DATA 2.TEL
3.SYSTEM 4.REPORT]
```

2

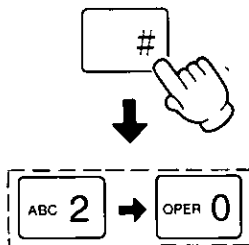

Press "#", then press "20".

```
20.AUTO STANDBY=OFF
[1.OFF 2.ON]
```

3

Example: Changing to "ON".

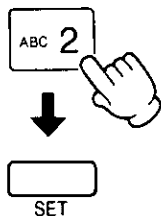

Press "2", then press **SET**.

```
20.AUTO STANDBY=ON
[1.OFF 2.ON]
```

```
PROGRAM[1.DATA 2.TEL
3.SYSTEM 4.REPORT]
```

4



Press **MENU** to end the operation.

```
THU JUN29 3:00PM 00
```

SYSTEM PROGRAMMING FUNCTIONS (CONT.)

SET DEFAULT

The SET DEFAULT setting;

All parameters return to initial setting (default) excluding LOGO (#01) and YOUR LOGO (#02).

NO: Parameters do not return to initial setting (Default).

YES: Parameters returns to initial setting.

NOTE:

Once you set to "YES", the parameters you have programmed are erased.

■ Changing parameter

1

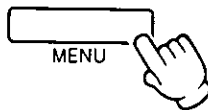

Press **MENU** 4 times.

- The PROGRAM indicator will light.
- This display will appear.

PROGRAM[1.DATA 2.TEL
3.SYSTEM 4.REPORT]

2

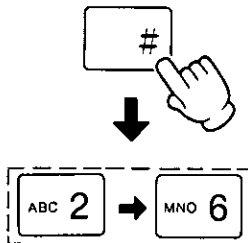

Press "#", then press "26".

26.SET DEFAULT=NO
[1.NO 2.YES]

3

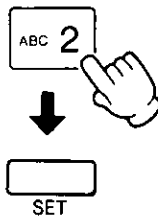

Press "2", then press **SET**.

Press "2", then press **SET**.

26.SET DEFAULT=YES
[1.NO 2.YES]

PARAMETER RESET OK?
=YES [1.NO 2.YES]

4

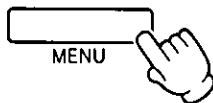

Press **MENU** to end the operation.

THU JUN29 3:00PM 00

TEST [PRINT OR MOTOR]

The TEST switch;

This function is useful for PRINTER testing and MOTOR testing switches.

OFF: Does not function. (Default)

PRINT: Prints the test pattern. (Refer to "MOTOR AND PRINTER TESTING" on page 29 in INSTALLATION MANUAL.)

MOTOR: Rotates the document feeder and printer motors. (Refer to "MOTOR AND PRINTER TESTING" and "MAINTENANCE" in INSTALLATION MANUAL.)

INDEX

A

Activity Report (Journal) 1-57, 1-58, 1-59
ANS/FAX position 1, 1-12, 2-2
Answer Back (Turning on the Speakerphone) 2-13
ATAS ID 2-3
AUTO Button 9, 1-6, 1-37
AUTO RECEIVE Button 8, 10, 1-12, 1-13
AUTO RECEIVE TIMER 1-21
Auto Receiving Mode 1-13, 1-21, 2-15
AUTO STANDBY 4-16
AUTO-LOGIC 2-6
Automatic document feeder 1-1
Automatic redial 1-8
AUX. LEADS 4-10

B

BACK LID Lever 8

C

Call Counter 2-5
Caller's Recording Time 2-4
Carrier Sheet 1-2
CLEAR Button 9
Combination Dialing 3-4
CONTRAST Button and Indicators 9
Control panel 8
COPY 1-65
CPC MODE 4-9

D

Date and Time 15
Delayed Polling 1-31
Delayed Transmission (XMT) 1-9, 1-43
Delayed Turnaround Polling 1-33
Delayed XMT Indicator 9
DIAL Keypad 10
DIALING MODE Selector 7
DIAL PULSE 4-11
Document tray 7, 4-7

E

Erasing Recorded Messages 2-6

F

Fast Forwarding Tape 2-5
FLASH Button 9, 3-4
FRONT LID Lever 8
FUNCTION Selector 1, 10

H

HALF-TONE Button and Indicator 9
Hands-Free to Handset 3-3
Handset to Hands-Free 3-3

I

ICM (Incoming Message)
Erasing 2-6
Individual Transmission (XMT) Report 1-63

L

List of Stored Phone Numbers 1-61

M

Making a Call 16, 3-1
Manual Dialing 16, 17
Manual Receiving Mode 1
Manual Reception 19, 1-11
Manual Transmission 18, 1-4
Message Memo 2-7
Marker Message 2-13
Memory Playback 2-11
Message Out 1-19
Monitoring Incoming Calls 2-9
Multi Polling 1-27, 1-45, 1-59
MUTE Button 7, 10, 3-4

INDEX (CONT.)

- O**
OGM 2-1, 2-14
One-Touch dialing 1-5, 1-35
ONE-TOUCH Stations 10
- P**
PAGE COUNTER 13, 1-16
Password Communications 1-50, 1-55
PAUSE Button 9, 2-6, 3-5
PLAYBACK/PAUSE Button 2-6
Playing Back Recorded Voice Messages 2-6
POLLING 1-23
POLLING Indicator 9
POLLING PASSWORD 1-23
POWER Switch 8
PRINTING REPORTS AND LISTS 1-57
PRIORITY Buttons 10, 1-41, 1-48
PROGRAM/REPORT Indicator 9
- R**
Re-recording the OGM 2-14
Receiving a Call 17, 3-2
Receiving a Document 1-13
Receiving Voice-Messages and
a Document 1-12, 2-2
Recording a 2-way conversation 2-8
Recording a Marker Message 2-13
Recording a Message Memo 2-7
Recording an OGM 2-1
Recording Paper Installation 4-5
Recording Time (ICM) 2-4
REDIAL Button 8, 10, 17, 3-2
Remote Control Functions 2-10
REMOTE FAX ID 1-17
Resetting tape 2-5
RESOLUTION Button and Indicators 9
REW Button 2-5
RINGER VOLUME Selector 7
RX SPEED 4-14
- S**
Saving Recorded Messages 2-9
Secret Phone Numbers 1-39
SERVICE MODE Switch 8
SET Button 9
SET DEFAULT 4-17
Single Station Polling 1-25, 1-44
Skipping the OGM 2-14
SP-PHONE Button and Indicator 8, 10
Speakerphone 2-13
Speed Dialing (AUTO Key) 1-6
STAMP Button and Indicator 10
STAMP DEFAULT 4-15
START/COPY Button 8, 10
STOP Button 8, 10, 1-65
SYSTEM SET UP 12
System Set Up List 12, 1-60
- T**
TONE Button 10, 3-4
TONE DETECT 4-12
Transmissible Document 1-1
TRANSMITTING A DOCUMENT 1-4, 1-14
Transmitting Reservation 1-7
TROUBLESHOOTING GUIDE 4-1
TEST 4-17
Turnaround Polling 1-29, 1-47
Turning On the Auto Recording Mode 2-15
TX SPEED 4-13
- V**
Voice Contact 1-15
Voice Time/Day Stamp 2-2
VOLUME Control 7
VOX 2-4
- X**
XMT RESERVATION Indicator 9

MEMO

MEMO

Panasonic Company
Division of Matsushita Electric Corporation of America
One Panasonic Way, Secaucus, New Jersey 07094

Panasonic Sales Company ("PSC"),
Division of Matsushita Electric of Puerto Rico, Inc.
San Gabriel Industrial Park, 65th Infantry Avenue, KM 9.5, Carolina, P.R. 00630

Free Manuals Download Website

<http://myh66.com>

<http://usermanuals.us>

<http://www.somanuals.com>

<http://www.4manuals.cc>

<http://www.manual-lib.com>

<http://www.404manual.com>

<http://www.luxmanual.com>

<http://aubethermostatmanual.com>

Golf course search by state

<http://golfingnear.com>

Email search by domain

<http://emailbydomain.com>

Auto manuals search

<http://auto.somanuals.com>

TV manuals search

<http://tv.somanuals.com>